

CTI 2552-A
8-CHANNEL ISOLATED RTD INPUT MODULE
INSTALLATION AND OPERATION GUIDE

Ver. 1.2
CTI Part # 062-00306-012



**Copyright © 2006 Control Technology Inc.
All rights reserved.**

This manual is published by Control Technology Inc., 5734 Middlebrook Pike, Knoxville, TN 37921. This manual contains references to brand and product names which are tradenames, trademarks, and/or registered trademarks of Control Technology Inc. Siemens® and SIMATIC® are registered trademarks of Siemens AG. Other references to brand and product names are tradenames, trademarks, and/or registered trademarks of their respective holders.

DOCUMENT DISCLAIMER STATEMENT

Every effort has been made to ensure the accuracy of this document; however, errors do occasionally occur. CTI provides this document on an "as is" basis and assumes no responsibility for direct or consequential damages resulting from the use of this document. This document is provided without express or implied warranty of any kind, including but not limited to the warranties of merchantability or fitness for a particular purpose. This document and the products it references are subject to change without notice. If you have a comment or discover an error, please call us toll-free at 1-800-537-8398.

PREFACE

This *Installation and Operation Guide* provides installation and operation instructions for the CTI 2552-A Eight Channel Isolated RTD Input Module for SIMATIC® 505 programmable controllers. We assume you are familiar with the operation of SIMATIC® 505 series programmable controllers. Refer to the appropriate SIMATIC® user documentation for specific information on the SIMATIC® 505 programmable controllers and I/O modules.

This *Installation and Operation Guide* is organized as follows:

Chapter 1 provides a description of the module.

Chapter 2 covers installation and wiring.

Chapter 3 is a guide to troubleshooting.

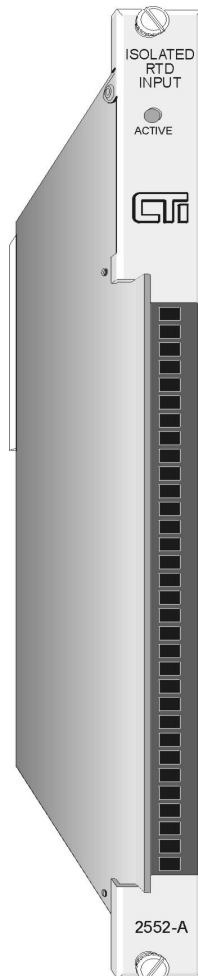

TABLE OF CONTENTS

PREFACE	iii
TABLE OF FIGURES	vii
USAGE CONVENTIONS	ix
CHAPTER 1. DESCRIPTION	1
1.1 Asynchronous Operation	1
1.1.1 Compatibility with Immediate I/O	1
1.2 100 Ohm or 120 Ohm RTDs	1
1.3 Digital Word Map	2
1.4 RTD Input to Digital Conversion	2
1.5 Effect of Out-of-Range Input Signals	3
1.6 Resolution	4
CHAPTER 2. INSTALLATION	5
2.1 Planning the Installation	5
2.2 Calculating the I/O Base Power Budget	5
2.3 Unpacking the Module	5
2.4 Configuring the Module	6
2.4.1 Select Temperature or Millivolt Input	6
2.4.2 Selecting 3 Wire or 4 Wire Operation	6
2.4.3 Selecting 100 Ohm or 120 Ohm RTD Inputs	6
2.4.4 Selecting Digital Filtering	7
2.4.5 Select Degrees Celsius or Fahrenheit	7
2.5 Inserting the Module Into the I/O Base	8
2.6 Wiring the Input Connectors	9
2.7 Checking Module Operation	13
CHAPTER 3. TROUBLESHOOTING	15
SPECIFICATIONS	17
JUMPER SETTINGS LOG SHEET	19
LIMITED PRODUCT WARRANTY	21
REPAIR POLICY	23

TABLE OF FIGURES

Figure 1	<i>The 2552-A 8-Channel RTD Input Module</i>	iii
Figure 2	<i>Word Input to the PLC from the Module</i>	2
Figure 3	<i>Example Change Input Level</i>	2
Figure 4	<i>Effect of Voltage Input - 100 Ohm Platinum</i>	3
Figure 5	<i>Effect of Voltage Input - Millivolts</i>	3
Figure 6	<i>Input Resolution</i>	4
Figure 7	<i>Factory Configuration Jumper Settings</i>	7
Figure 8	<i>Configuration Jumper Locations</i>	8
Figure 9	<i>Copper Wire Table at 25 Degrees Celsius</i>	9
Figure 10	<i>Screw Terminal Block Wiring</i>	10
Figure 11	<i>Wiring Diagram for 2, 3, or 4 Wire RTD</i>	11
Figure 12	<i>Wiring Diagram for Millivolt Measurements</i>	12
Figure 13	<i>Example I/O Configuration Chart</i>	13
Figure 14	<i>Troubleshooting Matrix</i>	15
Figure 15	<i>Factory Configuration Jumper Settings</i>	19

USAGE CONVENTIONS

NOTE:

Notes alert the user to special features or procedures.

CAUTION:

Cautions alert the user to procedures which could damage equipment.

WARNING:

Warnings alert the user to procedures which could damage equipment and endanger the user.

CHAPTER 1. DESCRIPTION

The 2552-A Eight Channel RTD Input Module is a member of Control Technology's family of I/O modules compatible with the SIMATIC® 505 series programmable controllers. The Model 2552-A is designed to translate 100 Ohm platinum RTDs, 120 Ohm nickel RTDs or millivolt input signals into equivalent digital words which are then sent to the programmable controller (PLC).

The 2552-A RTD Input Module features built-in independent two, three, or four lead compensation for each RTD input. Support for other RTD types is available through special request from the factory. Call CTI at 1-800-537-8398 to determine if support is available for your special RTD type.

1.1 Asynchronous Operation

The module operates asynchronously with respect to the PLC; a scan of the PLC and input sampling of the module do not occur at the same time. Instead, the module will translate all inputs in one module update (15 milliseconds maximum) and store the translated words in a buffer memory. The PLC retrieves the stored words from the module buffer memory at the start of the I/O scan.

1.1.1 Compatibility with Immediate I/O

The Model 2552-A has been tested and is compatible with the Immediate read function of the SIMATIC® 545 and 555 PLC.

1.2 100 Ohm or 120 Ohm RTDs

Each of the module's eight channels may be configured to receive either a 100 Ohm platinum RTD or a 120 Ohm nickel RTD input signal (two, three or four wire) or a DC voltage signal ranging from 0 to 100 millivolts. Selection of 100 Ohm or 120 Ohm RTDs or millivolts are made via internal switch and jumper settings (see sections 2.4.1 and 2.4.5).

1.3 Digital Word Map

RTD and/or millivolt signals are translated into a 14-bit digital word. Since the PLC requires a 16-bit input word, the 14-bit value from the converter is placed into a 16-bit word for transmittal to the PLC. As shown in the following figure, of the two bits not used for the digital word, one is used to show the sign of the word, while the other is used to note values which are "overrange."

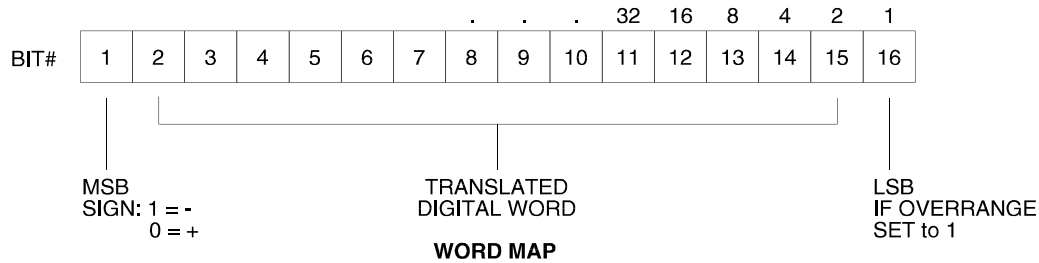

Figure 2 Word Input to the PLC from the Module

1.4 RTD Input to Digital Conversion

The following equations may be used to calculate the digital word in decimal format which will result from a particular RTD input:

$$\begin{aligned} \text{RTD Mode, Digital Word (WX)} &= \text{Degrees X 10} \\ \text{Millivolt Mode, Digital Word (WX)} &= \text{Millivolts X 100} \end{aligned}$$

As an example, the following figure illustrates the effects of a change in input level going from 0 degrees to 102.4 degrees in the RTD Input Mode.

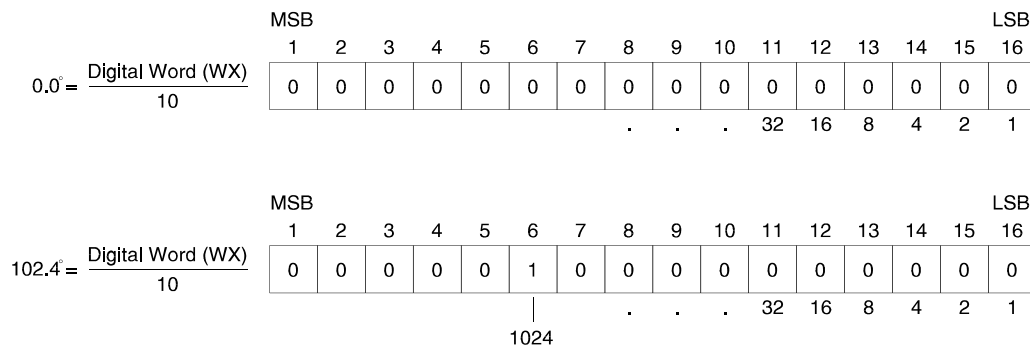

Figure 3 Example Change Input Level

1.5 Effect of Out-of-Range Input Signals

RTD inputs exceeding 849.8 degrees C for 100 Ohm platinum or 260.0 degrees C for 120 Ohm nickel will cause the overrange bit to be set. A maximum temperature of 849.9 degrees C for 100 Ohm platinum or 260.1 degrees C for 120 Ohm nickel will be returned for any positive overrange input.

Similarly an input below -199.8 degrees C for 100 Ohm platinum or -79.8 degrees C for 120 Ohm nickel will cause the overrange bit to be set. A minimum temperature of -199.9 degrees C for 100 Ohm platinum or -79.9 degrees C for 120 Ohm nickel will be returned for any negative underrange input.

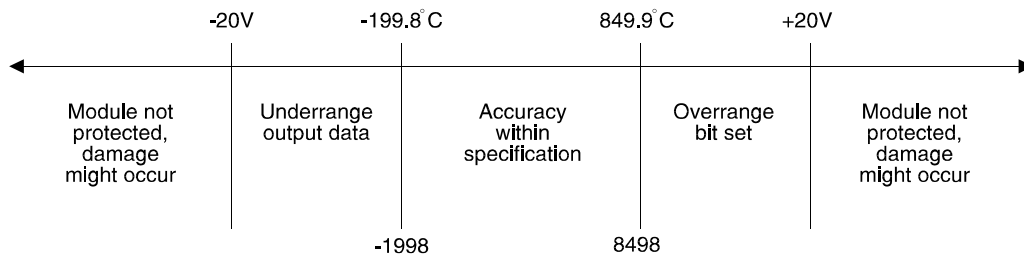

Figure 4 Effect of Voltage Input - 100 Ohm Platinum

Millivolt inputs exceeding 103.04 millivolts will cause the overrange bit to be set. A reading of 103.05 millivolts will be returned for any positive overrange input.

Similarly a millivolt input below 0 millivolts will cause the overrange bit to be set. A reading of 1 millivolt will be returned for any negative underrange input.

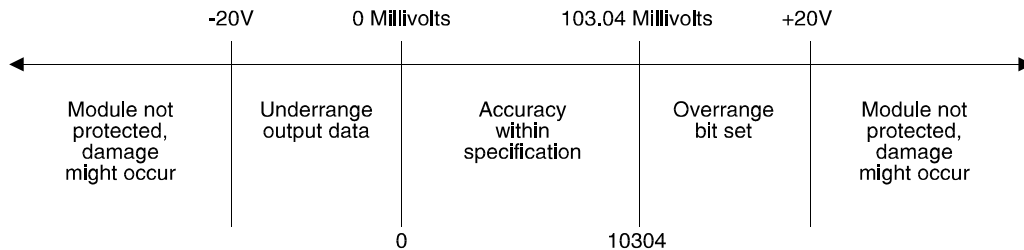

Figure 5 Effect of Voltage Input - Millivolts

1.6 Resolution

The module has a resolution of approximately 0.2 degrees C, 0.4 degrees F or exactly 0.02 millivolts.

The chart below shows the corresponding input resolution per step for each of the input configuration modes:

UNITS	DIGITAL COUNTS/STEP	INPUT RESOLUTION PER STEP
Temp Degrees C	2	~ 0.2° C
Temp Degrees F	2	~ 0.4° F
Millivolts	2	0.02 Millivolts

Figure 6 *Input Resolution*

CHAPTER 2. INSTALLATION

The installation of the 2552-A Eight Channel RTD Input Module involves the following steps:

1. Planning the installation
2. Configuring the module
3. Inserting the module into the I/O base
4. Wiring the module input connector
5. Checking module operation

The steps listed above are explained in detail in the following pages.

2.1 Planning the Installation

Planning is the first step in the installation of the module. This involves calculating the I/O base power budget and routing the input signal wiring to minimize noise. The following sections discuss these important considerations.

2.2 Calculating the I/O Base Power Budget

The Model 2552-A requires 2.8 watts of +5 V power from the I/O base. Use this figure to verify that the base power supply capacity is not exceeded.

2.3 Unpacking the Module

Open the shipping carton and remove the special anti-static bag which contains the module.

CAUTION:

HANDLING STATIC SENSITIVE DEVICES

The components on the 2552-A module printed circuit card can be damaged by static electricity discharge. To prevent this damage, the module is shipped in a special anti-static bag. Take the following precautions before removing the module from the bag, when opening the module, and when handling the printed circuit card during configuration.

Discharge any static potential by holding the module in its anti-static bag and touch the metal chassis of the PLC. During the configuration step, hold the printed circuit card only by its edges. Do not touch the circuit card pin connectors, or solder connections.

After discharging any static build-up, remove the module from the static bag. Do not discard the

static bag. You will need it for the following configuration procedure.

2.4 Configuring the Module

The Model 2552-A must be configured for 100 Ohm platinum or 120 Ohm nickel RTDs (2, 3 or 4 wire) or millivolt range and digital filtering/no filtering mode before wiring the input connectors and inserting the module into the I/O base.

Changing the module input channel configuration involves the following steps:

NOTE: FACTORY SHIPPING CONFIGURATION
As shipped, all input channels are configured 100 Ohm platinum, 3 wire RTDs, degrees Celsius and digital filtering enabled for temperature measurements.

1. Selecting temperature or millivolt measurement
2. Selecting 3 or 4 wire compensation
3. Selecting 100 Ohm platinum or 120 Ohm nickel RTD input mode for each channel
4. Selecting digital filtering or no filtering for the module
5. Logging the configuration jumper settings for future reference

Each of these steps is described in the following sections.

2.4.1 Select Temperature or Millivolt Input

Locate DIP switch SW2 (Temperature/Millivolt Switches in Figure 8) on the 2552-A card and for each input 1-8 select either Temperature or Millivolt by turning each switch open or closed. The "CLOSED" position corresponds to Temperature.

2.4.2 Selecting 3 Wire or 4 Wire Operation

Locate the 8 "3 wire/4 wire" jumpers corresponding to input channels 1 through 8. These jumpers are located adjacent to the input terminal strip (see Figure 8). For each input channel, select 3 wire mode by placing the jumper in the "3 wire" position or 4 wire mode by placing the jumper in the "4 wire" position. If 2 wire operation is desired, use the "4 wire" position.

2.4.3 Selecting 100 Ohm or 120 Ohm RTD Inputs

Locate DIP switch SW1 (RTD Type Switches in Figure 8) on the 2552-A circuit card and select either 100 or 120 type RTD for each of the eight inputs by turning each switch open or closed. The "CLOSED" position corresponds to 100 Ohm platinum RTD input.

2.4.4 Selecting Digital Filtering

Locate the Digital Filtering Jumper JP3 (see Figures 8). To enable digital filtering, set the jumper in the ENABLED position. Since many analog input signals contain noise, CTI recommends using digital filtering unless maximum response time is required.

2.4.5 Select Degrees Celsius or Fahrenheit

Locate the temperature scaling jumper JP4 on the right hand side of the module (see Figure 8) and select either degrees Fahrenheit or Celsius by positioning the jumper in the DEG F or DEG C position.

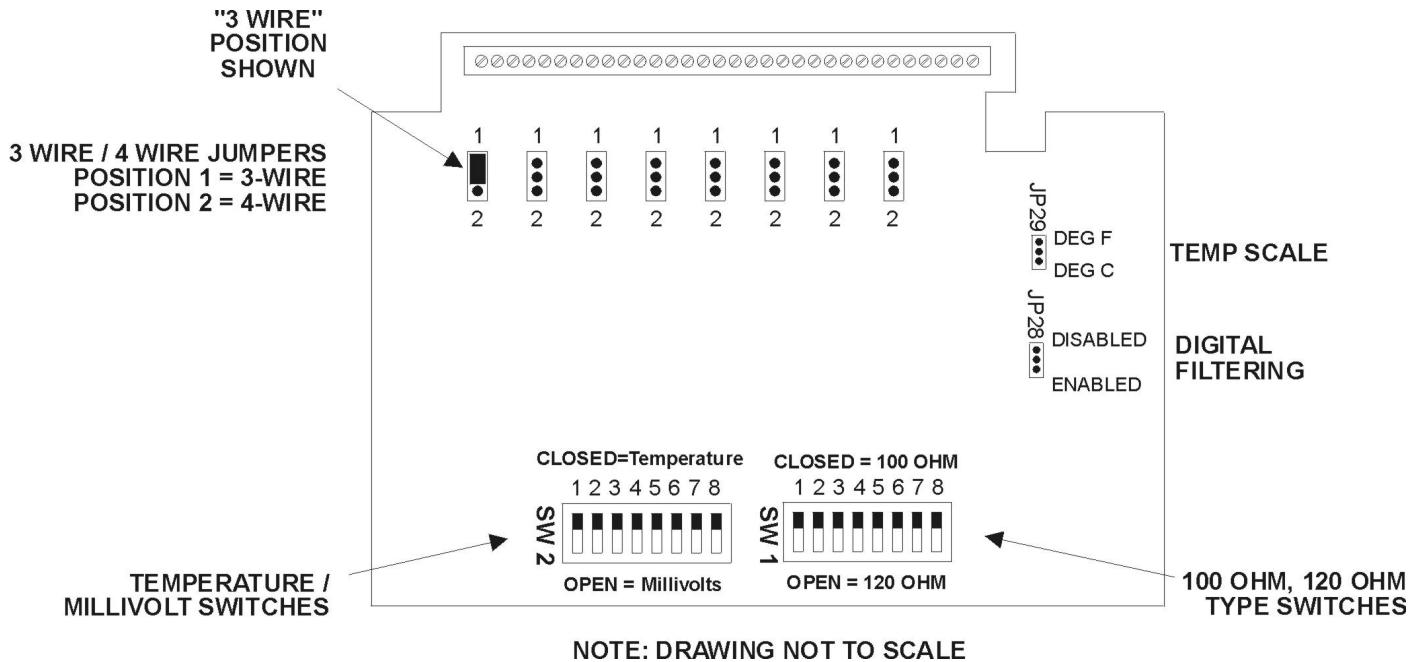

Figure 8 Jumper Locations

2.5 Inserting the Module Into the I/O Base

Insert the module into the I/O base by carefully pushing the module into the slot. When the module is fully seated in the slot, tighten the captive screws at the top and bottom to hold the module in place. To remove the module from the I/O base, loosen the captive screws, then remove the module from the I/O base. Be careful not to damage the connector card at the back of the module when inserting or removing the module.

2.6 Wiring the Input Connectors

RTD input signals are accepted through a screw terminal connector block located on the front of the module. Consult the RTD manufacturer's recommendations for selecting the input wire type and size.

The Model 2552-A uses a fixed connector to terminate field wiring. This is used because the chemistry of a removable connector may have an adverse effect on the accuracy of the measurement. CTI has carefully selected a connector that minimizes this effect.

Refer to Figure 10 for correct wiring for 2, 3, or 4 wire RTDs to the Model 2552-A. Each channel group consists of four screw terminals. See Figure 10.

The Model 2552-A may compensate for up to 20 Ohm of lead resistance per wire. Use the table below in planning the maximum distance the RTD may be located from the module.

AWG	Ohms/Km	Ohms/Meter	Ohms/Ft	Ohms/1000Ft
12	5.33	0.00533	0.00162	1.62
14	8.47	0.00847	0.00258	2.58
16	13.50	0.01350	0.00411	4.11
18	21.40	0.02140	0.00652	6.52
20	34.10	0.03410	0.01039	10.39
22	54.20	0.05420	0.01652	16.52
24	86.10	0.08610	0.02624	26.24
26	137.00	0.13700	0.04176	41.76
28	218.00	0.21800	0.06645	66.45
30	356.00	0.35600	0.10851	108.51

Copper Wire Table at 25 Degrees Celsius

To assign an input to a specific channel, locate the appropriate channel position on the screw terminal block as shown in the following figure:

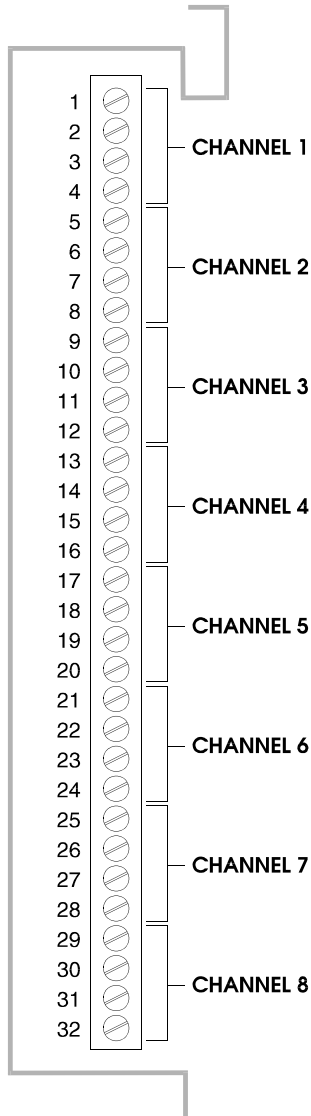

Figure 9 *Screw Terminal Block Wiring*

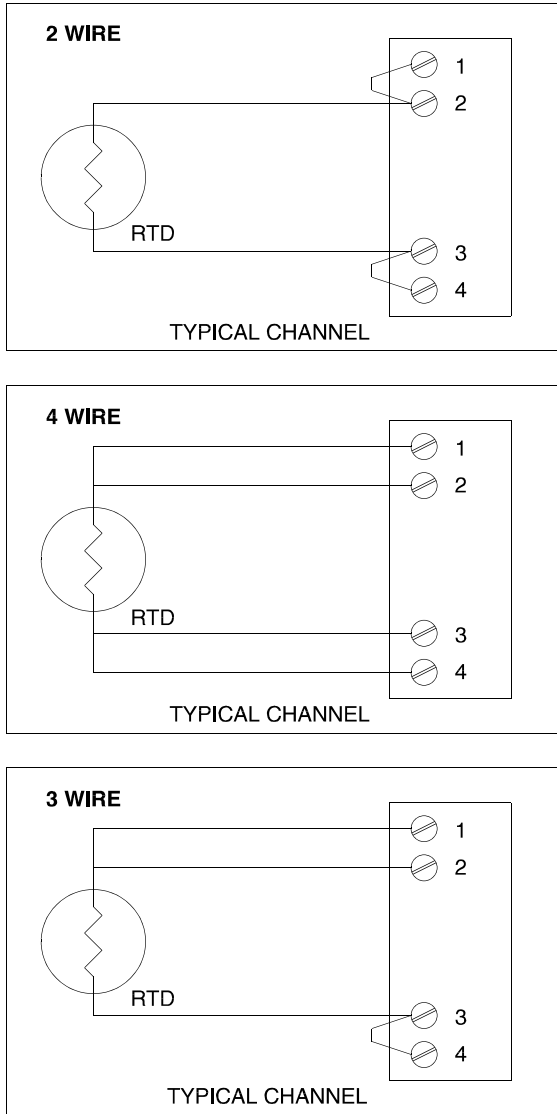

Figure 10 *Wiring Diagram for 2, 3, or 4 Wire RTD*

CAUTION:
RTD wires must be of the same gauge.

CAUTION:

For proper operation, ensure that the 2552-A is not subjected to large temperature gradients during operation.

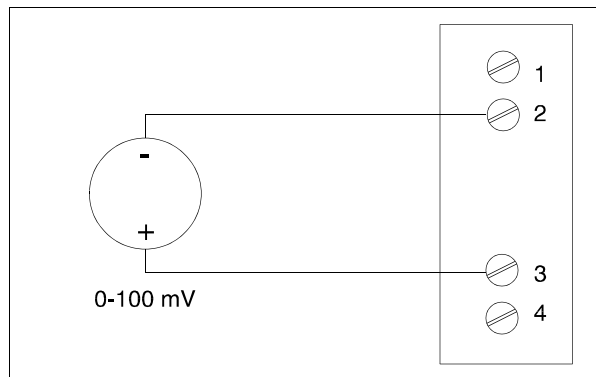

Figure 11 Wiring Diagram for Millivolt Measurements

NOTE:

If a separate shield is used for RTD or Millivolt measurements it should be terminated at screw position #2 of each channel group. The shielding for the cable should always be terminated at the Model 2552-A. Each isolated input channel contains its own local ground for the shield wire. The input isolation amplifier is designed in this manner by the manufacturer. Standard practices usually require that all shields be tied together and grounded at a single point. In an isolated system this will actually impede the system to reject noise. The correct method for terminating the shields on an isolated channel is to connect them to the channel's local ground. This will provide the best performance. There should never be any shield termination at the source end of the signal wire.

2.7 Checking Module Operation

First turn on the base supply power. If the module diagnostics detect no problems, the status indicator on the front of the module will light. If the status indicator does not light (or goes out during operation), the module has detected a failure. For information on viewing failed module status, refer to your SIMATIC® TISOFT user manual. To diagnose and correct a module failure, refer to the next section on troubleshooting.

You must also check that the module is configured in the memory of the PLC. This is important because the module will appear to be functioning regardless of whether it is communicating with the PLC. To view the PLC memory configuration chart listing all slots on the base and the inputs or outputs associated with each slot, refer to your SIMATIC® or TISOFT Programming Manual. An example chart is shown in the following figure.

I/O MODULE DEFINITION FOR CHANNEL 1				BASE 00		
I/O SLOT	ADDRESS	X	Y	WX	WY	SPECIAL FUNCTION
01	0001	00	00	08	00	NO
02	0002	00	00	00	00	NO
.
.
15	0000	00	00	00	00	NO
16	0000	00	00	00	00	NO

Figure 12 Example I/O Configuration Chart

In this example, the 2552-A Module is inserted in slot 1 in I/O base 0. Data for channel 1 appears in word location WX1, data for channel 2 appears in word location WX2, etc. For your particular module, look in the chart for the number corresponding to the slot occupied by the module. If word memory locations appear on this line, then the module is registered in the PLC memory and the module is ready for operation.

If the line is blank or erroneous, re-check the module to ensure that it is firmly seated in the slots. Generate the PLC memory configuration chart again. If the line is still incorrect, contact your local distributor or CTI at 1-800-537-8398 for further assistance.

NOTE:

*In the event a CTI analog detects an onboard module failure, the module will assert the module fail line and report the module failure in the I/O Status Word, which is reported to the PLC CPU. CTI strongly recommends the user application monitor the **I/O Module Status Words** which are Status Words 11-26 and apply to SIMATIC® Controllers 545, 555, 560 & 565 and the 575. The I/O Module Status Word can be used to report a module failure for an I/O Module in any of the 505 I/O slots. Please refer to Siemens® SIMATIC® 505 Programming Reference Manual for more information. If a module failure is reported by the status word, the module should be replaced with a working unit and the failed module sent infor repair.*

CHAPTER 3. TROUBLESHOOTING

If the module provides improper readings or the status indicator is not on, use the following chart to determine the appropriate corrective action.

SYMPTOM	PROBABLE CAUSE	CORRECTIVE ACTION
Indicator is not lit	Base or PC power is off Module not seated	Turn base or PC on Reseat module in 505 rack
Incorrect inputs	Wrong addresses for word input Not logged-in Incorrectly calibrated	Check program for correct word input addresses Read I/O configuration Return the module to CTI for calibration
All negative temperatures	Blown Fuse	Return the module to CTI for service

Figure 13 *Troubleshooting Matrix*

When it is inconvenient to visually check the status indicator, use the TISOFT "Display Failed I/O" or "Show PLC Diagnostics" support functions.

CAUTION:

The module fuse is not user serviceable. If this fuse is blown, the module has a serious component failure and should be returned to CTI for repair.

If after consulting the chart above, you are unable to diagnose or solve the problem, contact your local distributor or CTI at 1-800-537-8398 for further assistance.

SPECIFICATIONS

Channels per Module:	8 (eight)
Size:	Single Wide 505 Module
Standard RTD Types:	
100 Ohm platinum	TCR = 0.003850, Ohm/Ohm/deg C, (European DIN 43760) -198 to 849.8 degrees Celsius -327.6 to 1561.6 degrees Fahrenheit
120 Ohm nickel	TCR = 0.00672, Ohm/Ohm/deg C, -79.8 to 260.0 degrees Celsius -111.6 to 500.0 degrees Fahrenheit
Absolute Temp Accuracy:	+/- 0.4 degrees Celsius at calibrated temperature 25 C +/- 0.8 degrees Fahrenheit over operating range 0 to 60 C (worst case)
Millivolt Range:	0 to 103.04 Millivolts
Millivolt Input impedance:	Greater than 10 KOhm @60Hz Greater than 1000 MegOhm @DC
Absolute Millivolt Accuracy:	+/- 0.5 percent full scale or +/- 500 uV
Repeatability:	.05% Full Scale (temp or mV)
Resolution:	.025% Full Scale (temp or mV)
Common Mode Rejection:	Greater than 110 dB @ 60Hz (digital filtering disabled) Greater than 160 dB @ 60Hz (digital filtering enabled)
Normal Mode Rejection:	Greater than 45 dB @ 60Hz (digital filtering enabled)

Input Protection:	20,000 Volts ESD +/- 20 VDC from any input to channel common +/- 20 VDC from any input to any other input on same channel (channels are isolated from each other by 1500 VDC)
Input Bandwidth:	5.5 Hz (digital filtering disabled) 0.16 Hz (digital filtering enabled)
Filtering Time Constant: (100 mV input step)	18 mS (digital filtering disabled) 1.0 Sec (digital filtering enabled)
Update Time:	15 milliseconds for all eight channels
Open RTD Reporting:	To PLC as bit number one set
Bias Current to RTD Probe:	250 microamp nominal
Wire Resistance Compensation:	Up to 20 Ohms per lead wire.
Module Power from Base:	2.8 watts @ +5VDC
Isolation:	1500 VDC channel to channel and channel to PLC
Field Wiring Connector:	Accepts 18 -26 AWG
Mechanical:	Size single-wide 505 Module
Operating Temperature:	0 to 60 degrees Celsius (32 to 140 degrees Fahrenheit)
Storage Temperature:	-40 to 85 degrees Celsius (-40 to 185 degrees Fahrenheit)
Humidity:	0% to 95%, noncondensing
Agency Approvals:	UL, UL Canada FM (Class I, Div 2), CE

Specifications subject to change without notice.

JUMPER SETTINGS LOG SHEET

Record the configuration jumper settings on this log for future reference. Make additional copies if necessary.

CHANNEL NUMBER	3 WIRE / 4 WIRE RTD COMPENSATION JUMPER	POSITION		SWITCH POSITION VS CHANNEL # SW1 & SW2	RTD TYPE SWITCHES (SW1)		TEMP / MILLIVOLT SWITCHES (SW2)	
		1	2		OPEN	CLOSED	OPEN	CLOSED
1	JP2	3 WIRE	4 WIRE	1	120 OHM	100 OHM	Millivolts	Temp
2	JP4	3 WIRE	4 WIRE	2	120 OHM	100 OHM	Millivolts	Temp
3	JP6	3 WIRE	4 WIRE	3	120 OHM	100 OHM	Millivolts	Temp
4	JP8	3 WIRE	4 WIRE	4	120 OHM	100 OHM	Millivolts	Temp
5	JP10	3 WIRE	4 WIRE	5	120 OHM	100 OHM	Millivolts	Temp
6	JP12	3 WIRE	4 WIRE	6	120 OHM	100 OHM	Millivolts	Temp
7	JP14	3 WIRE	4 WIRE	7	120 OHM	100 OHM	Millivolts	Temp
8	JP16	3 WIRE	4 WIRE	8	120 OHM	100 OHM	Millivolts	Temp
ALL CHANNELS		DIGITAL FILTERING JUMPER			FAHRENHEIT / CENTIGRADE SELECT			
1-8		JP28 Filtering Disabled Filtering Enabled			JP29 Degrees F Degrees C			

USER NOTES

LIMITED PRODUCT WARRANTY

CTI warrants that this CTI Industrial Product shall be free from defects in material and workmanship for a period of one (1) year after purchase from CTI or from an authorized CTI Industrial Distributor. This CTI Industrial Product will be newly manufactured from new and/or serviceable used parts which are equal to new in the Product.

Should this CTI Industrial Product fail to be free from defects in material and workmanship at any time during this one (1) year warranty period, CTI will repair or replace (at its option) parts or Products found to be defective and shipped prepaid by the customer to a designated CTI service location along with proof of purchase date and associated serial number. Repair parts and replacement Product furnished under this warranty will be on an exchange basis and will be either reconditioned or new. All exchanged parts or Products become the property of CTI. Should any Product or part returned to CTI hereunder be found by CTI to be without defect, CTI will return such Product or part to the customer.

This warranty does not include repair of damage to a part or the Product resulting from: failure to provide a suitable environment as specified in applicable Product specifications, or damage caused by an accident, disaster, acts of God, neglect, abuse, misuse, transportation, alterations, attachments, accessories, supplies, non-CTI parts, non-CTI repairs or activities, or to any damage whose proximate cause was utilities or utility like services, or faulty installation or maintenance done by someone other than CTI.

Control Technology Inc. reserves the right to make changes to the Product in order to improve reliability, function, or design in the pursuit of providing the best possible Product. CTI assumes no responsibility for indirect or consequential damages resulting from the use or application of this equipment.

THE WARRANTY SET FORTH ABOVE IN THIS ARTICLE IS THE ONLY WARRANTY CTI GRANTS AND IT IS IN LIEU OF ANY OTHER IMPLIED OR EXPRESSED GUARANTY OR WARRANTY ON CTI PRODUCTS, INCLUDING WITHOUT LIMITATION, ANY WARRANTY OF MERCHANTABILITY OR OF FITNESS FOR A PARTICULAR PURPOSE AND IS IN LIEU OF ALL OBLIGATIONS OR LIABILITY OF CTI FOR DAMAGES IN CONNECTION WITH LOSS, DELIVERY, USE OR PERFORMANCE OF CTI PRODUCTS OR INTERRUPTION OF BUSINESS, LOSS OF USE, REVENUE OR PROFIT. IN NO EVENT WILL CTI BE LIABLE FOR SPECIAL, INCIDENTAL, OR CONSEQUENTIAL DAMAGES.

SOME STATES DO NOT ALLOW THE EXCLUSION OR LIMITATION OF INCIDENTAL OR CONSEQUENTIAL DAMAGES FOR CONSUMER PRODUCTS, SO THE ABOVE LIMITATIONS OR EXCLUSIONS MAY NOT APPLY TO YOU.

THIS WARRANTY GIVES YOU SPECIFIC LEGAL RIGHTS, AND YOU MAY ALSO HAVE OTHER RIGHTS WHICH MAY VARY FROM STATE TO STATE.

REPAIR POLICY

In the event that the Product should fail during or after the warranty period, a Return Material Authorization number (RMA) can be requested verbally or in writing from CTI main offices. Whether this equipment is in or out of warranty, a Purchase Order number provided to CTI when requesting the RMA number will aid in expediting the repair process. The RMA number that is issued and your Purchase Order number should be referenced on the returning equipment's shipping documentation. Additionally, if under warranty, proof of purchase date and serial number must accompany the returned equipment. The current repair and/or exchange rates can be obtained by contacting CTI's main office at 1-800-537-8398.

When returning any module to CTI, follow proper static control precautions. Keep the module away from polyethylene products, polystyrene products and all other static producing materials. Packing the module in its original conductive bag is the preferred way to control static problems during shipment. **Failure to observe static control precautions may void the warranty.** For additional information on static control precautions, contact CTI's main office at 1-800-537-8398.