



**HarmonicGuard<sup>®</sup> Series Drive-Applied Harmonic Filter  
Installation, Operation, and Maintenance Manual**



TCI, LLC  
7878 N. 86th Street  
Milwaukee, Wisconsin 53224

Phone: 414-357-4480  
Fax: 414-357-4484  
Helpline: 800-TCI-8282

Web Site: <http://www.transcoil.com>

© 2011



# Table of Contents

<b>Introduction .....</b>	<b>2</b>
Receiving Inspection and Storage .....	4
Pre-installation Planning.....	5
Installation Guidelines.....	6
HG7 Harmonic Filter Operation .....	8
Installation .....	9
Maintenance and Service.....	10
Product Description.....	14
Drawings .....	17
<b>Standard Filter (ST).....</b>	<b>23</b>
<b>Contactor Option (STC).....</b>	<b>24</b>
<b>Power Monitor Package Option (XM).....</b>	<b>25</b>
HG7 “XM” Option Operation.....	29
The HG2™ Protection Monitor .....	30
<b>Component Package Option (CP).....</b>	<b>47</b>
Installation .....	49

# INTRODUCTION

## Introduction

### Safety Instructions Overview

This section provides the safety instructions which must be followed when installing, operating, and servicing the HG7 harmonic filter. If neglected, physical injury or death may follow, or damage may occur to the filter or equipment connected to the HG7 harmonic filter. The material in this chapter must be read and understood before attempting any work on, or with, the product.

The HG7 harmonic filter is intended to be connected to the input terminals of one or more adjustable speed drives. Three-phase power is connected to the input terminals of the HG7 and power is supplied to the drive or drives through the HG7. The instructions, and particularly the safety instructions, for the drives, motors and any other related equipment must be read, understood and followed when working on any of the equipment.



### Warnings and Cautions

This manual provides two types of safety instructions. Warnings are used to call attention to instructions, which describe steps, which must be taken to avoid conditions, which can lead to a serious fault condition, physical injury or death.

Cautions are used to call attention to instructions that describe steps that must be taken to avoid conditions that can lead to a malfunction and possible equipment damage.

#### Warnings

Readers are informed of situations that can result in serious physical injury and/or serious damage to equipment with warning statements highlighted by the following symbols:

<b>Warning</b> 	Dangerous Voltage Warning: warns of situations in which a high voltage can cause physical injury and/or damage equipment. The text next to this symbol describes ways to avoid the danger.
<b>Warning</b> 	General Warning: warns of situations that can cause physical injury and/or damage equipment by means other than electrical. The text next to this symbol describes ways to avoid the danger.
<b>Warning</b> 	Electrostatic Discharge Warning: warns of situations in which an electrostatic discharge can damage equipment. The text next to this symbol describes ways to avoid the danger.

#### Cautions







Readers are informed of situations that can lead to a malfunction and possible equipment damage with caution statements:

<b>Caution</b>	General Caution: identifies situations that can lead to a malfunction and possible equipment damage. The text describes ways to avoid the situation.
----------------	--

# INTRODUCTION

## General Safety Instructions

These safety instructions are intended for all work on the HG7. Additional safety instructions are provided at appropriate points on other sections of this manual.

<b>Warning</b> 	Be sure to read, understand and follow all safety instructions.
<b>Warning</b> 	Only qualified electricians should carry out all electrical installation and maintenance work on the HG7 harmonic filter.
<b>Warning</b> 	All wiring must be in accordance with the National Electrical Code (NEC) and/or any other codes that apply to the installation site.
<b>Warning</b> 	Disconnect all power before working on the equipment. Do not attempt any work on a powered HG7 filter.
<b>Warning</b> 	The HG7 harmonic filter, drive, motor, and other connected equipment must be properly grounded.
<b>Warning</b> 	After switching off the power, always allow 5 minutes for the capacitors in the HG7 filter and in the drive to discharge before working on the HG7, the drive, the motor, or the connecting wiring. It is a good idea to check with a voltmeter to make sure that all sources of power have been disconnected and that all capacitors have discharged before beginning work.

# INTRODUCTION

## Receiving Inspection and Storage

Thank you for selecting the HG7 Drive-Applied Harmonic Filter. TCI has produced this filter for use in many variable speed drive applications that require input power line harmonic current reduction. This manual describes how to install, operate and maintain the HG7 harmonic filter.

### Receiving Inspection

The HG7 harmonic filter has been thoroughly inspected and functionally tested at the factory and carefully packaged for shipment. When you receive the unit, you should immediately inspect the shipping container and report any damage to the carrier that delivered the unit. Verify that the part number of the unit you received is the same as the part number listed on your purchase order.

### TCI Limited Warranty Policy

TCI, LLC (“TCI”) warrants to the original purchaser only that its products will be free from defects in materials and workmanship under normal use and service for a period originating on the date of shipment from TCI and expiring at the end of the period described below:

Product Family	Warranty Period
KLR, KDR	For the life of the drive with which they are installed.
KLC, KLCUL, KMG, V1k	One (1) year of useful service, not to exceed 18 months from the date of shipment.
HG7, KH, 3H, KRF	Three (3) years from the date of shipment.
KCAP, KTR, KMP	Five (5) years from the date of shipment.
All Other Products	One (1) year of useful service, not to exceed 18 months from the date of shipment.

The foregoing limited warranty is TCI’s sole warranty with respect to its products and TCI makes no other warranty, representation, or promise as to the quality or performance of TCI’s products. THIS EXPRESS LIMITED WARRANTY IS GIVEN IN LIEU OF AND EXCLUDES ANY AND ALL EXPRESS OR IMPLIED WARRANTIES INCLUDING, WITHOUT LIMITATION, ANY IMPLIED WARRANTY OF MERCHANTABILITY OR FITNESS FOR A PARTICULAR PURPOSE.

This warranty shall not apply if the product was:

- a) altered or repaired by anyone other than TCI;
- b) applied or used for situations other than those originally specified; or
- c) subjected to negligence, accident, or damage by circumstances beyond TCI’s control, including but not limited to, improper storage, installation, operation, or maintenance.

If, within the warranty period, any product shall be found in TCI’s reasonable judgment to be defective, TCI’s liability and the Buyer’s exclusive remedy under this warranty is expressly limited, at TCI’s option, to (i) repair or replacement of that product, or (ii) return of the product and refund of the purchase price. Such remedy shall be Buyer’s sole and exclusive remedy. TCI SHALL NOT, IN ANY EVENT, BE LIABLE FOR INCIDENTAL DAMAGES OR FOR CONSEQUENTIAL DAMAGES INCLUDING, BUT NOT LIMITED TO, LOSS OF INCOME, LOSS OF TIME, LOST SALES, INJURY TO PERSONAL PROPERTY, LIABILITY BUYER INCURS WITH RESPECT TO ANY OTHER PERSON, LOSS OF USE OF THE PRODUCT OR FOR ANY OTHER TYPE OR FORM OF CONSEQUENTIAL DAMAGE OR ECONOMIC LOSS.

The foregoing warranties do not cover reimbursement for removal, transportation, reinstallation, or any other expenses that may be incurred in connection with the repair or replacement of the TCI product.

The employees and sales agents of TCI are not authorized to make additional warranties about TCI’s products. TCI’s employees and sales agents oral statements do not constitute warranties, shall not be relied upon by the Buyer, and are not part of any contract for sale. All warranties of TCI embodied in this writing and no other warranties are given beyond those set forth herein.

TCI will not accept the return of any product without its prior written approval. Please consult TCI Customer Service for instructions on the Return Authorization Procedure.

### Storage Instructions

If the HG7 harmonic filter is to be stored before use, be sure that it is stored in a location that conforms to published storage humidity and temperature specifications stated in Table 2 (HG7 Harmonic Filter Technical Specifications). Store the unit in its original packaging.

# INTRODUCTION

## Pre-installation Planning

### Verify the Application

#### *HG7 Ratings*

Make sure that the HG7 harmonic filter is correct for the application. The voltage ratings of the filter must match the input voltage rating of the connected drive. The horsepower and current ratings of the filter must be adequate for the connected load. The kVar rating of the HG7 filter should be 30% of the horsepower rating for 3-phase diode bridge rectifier loads such as PWM AC drives.

### Select a Suitable Location

#### *Environment*

Locating the HG7 in a suitable environment will help assure proper performance and a normal operating life. Refer to the environmental specifications listed in Table , marked on the unit's nameplate and/or noted on the drawings furnished with the unit.

<b>Warning</b>	Unless specifically labeled as approved for such use, this equipment is not suitable for use in an explosive atmosphere or in a "Hazardous (Classified) Location" as defined in article 500 of the National Electrical code.
----------------	--

The unit must be installed in an area where it will not be exposed to:

- ◆ Direct sunlight
- ◆ Rain or dripping liquids (unless filter is in a 3R enclosure)
- ◆ Corrosive liquids or gasses
- ◆ Explosive or combustible gases or dust
- ◆ Excessive airborne dirt and dust
- ◆ Excessive vibration

#### *Working Space*

Provide sufficient access and working space around the unit to permit ready and safe installation, operation and maintenance. Make sure that the installation conforms to all working space and clearance requirements of the National Electrical Code (NEC) and/or any other applicable codes. Provide sufficient unobstructed space to allow cooling air to flow through the unit.

### Mounting an Open Panel Unit

If you are mounting an open panel unit in your own enclosure, you must provide an enclosure that is adequately sized and ventilated sufficiently to prevent overheating. The rating and dimension tables for open panel units list the watts of heat loss that is dissipated by the HG7 harmonic filter. The maximum temperature of the air around the HG7 filter capacitors and Protection Monitor should not exceed 50°C (122°F).

### Power Wiring

When selecting a mounting location for the HG7 filter, plan for the routing of the power wiring.

Route the conduit and wiring from the power source to the filter and then to the variable speed drive.

The HG7 is provided with internal fuses. Additional fuses may be required at the connecting point to protect the tap conductors. Refer to the National Electrical Code (NEC) and/or any other applicable codes.

# INTRODUCTION

## Installation Guidelines

### **Mounting**

The HG7 must be mounted vertically on a smooth, solid surface, free from heat, dampness, and condensation.

### **Wiring**

#### *Cable Entry Locations*

The enclosed HG7 harmonic filters are not provided with enclosure wiring knockouts. A selection can be made at the time of installation. Typical or recommended cable entry locations are shown in the drawings section of this manual.

#### *Field Wiring Connection Terminals*

Compression type terminals are provided for all field wiring connections. The control circuit terminals will accommodate 18 AWG to 10 AWG wire and should be tightened to 7 lbs. - in. torque. The wire size capacity ranges and tightening torque for the grounding and power terminals are listed in the drawings and other information shipped with the unit.



# INTRODUCTION

## *Grounding*

The HG7 panel equipment-grounding lug must be connected to the ground of the wiring system. The equipment grounding connection must conform to the requirements of the National Electric Code (NEC) and/or any other codes that apply to the installation site. The ground connection must be made using a wire conductor. Metallic conduit is not a suitable grounding conductor. The integrity of all ground connections should be periodically checked.

## *Power Wiring*

<b>Caution</b>	<p>Use copper wire that is appropriate for the voltage and current rating of the equipment. The wire selection must conform to the requirements of the National Electrical Code and/or other applicable electrical codes.</p> <p>For units rated less than 100 amps, use wire with an insulation temperature rating of 60°C or higher.</p> <p>For units rated 100 amps or more, use wire with an insulation temperature rating of 75°C or higher.</p>
----------------	---

Connect three-phase power of the appropriate voltage and current capacity to the branch circuit protective device to the HG7 input power terminals. **Note:** in large units, the input power conductors are connected directly to the input terminals on the line reactors.

Connect the output terminals of the HG7 to the input power terminals of the adjustable speed drive. **Note:** in large units, the output power conductors are connected directly to the output terminals on the line reactors. Refer to the adjustable speed drive installation instructions for additional information.

# INTRODUCTION

## HG7 Harmonic Filter Operation

<b>Caution</b>	Thoroughly check the installation before applying power and operating the equipment for the first time.
----------------	---

### *Before Applying Power for the First Time*

Inspect the installation to make sure that all equipment has been completely and correctly installed in accordance with the *Installation Guidelines* section of this manual.

- ◆ Check to see that the cooling fan(s) are operating in units so equipped.

### **Operation**

Since the HG7 is a passive filter, it is always operating whenever the drive is operating.

# INTRODUCTION

## Installation

### Intended Audience

This manual is intended for use by all personnel responsible for the installation, operation and maintenance of the HG7 harmonic filters. Such personnel are expected to have knowledge of electrical wiring practices, electronic components and electrical schematic symbols.

### Additional Information

<b>Caution</b>	<p>This manual provides general information describing your HG7 harmonic filter. Be sure to carefully review the more specific information that is provided by the drawings shipped with the unit. Information provided by the drawings takes precedence over the information provided in this manual.</p> <p>The ratings, dimensions and weights given in this manual are approximate and should not be used for any purpose requiring exact data. Contact the factory in situations where certified data is required. All data is subject to change without notice.</p>
----------------	---

### Installation Checklist

The following are the key points to be followed for a successful installation. These points are explained in detail in the following sections of this manual.

- Make sure that the installation location will not be exposed to direct sunlight, corrosive or combustible airborne contaminants, excessive dirt or liquids.
- Select a mounting area that will allow adequate cooling air and maintenance access.
- Make sure that all wiring conforms to the requirements of the National Electric Code (NEC) and/or other applicable electrical codes.
- Connect the HG7 equipment-grounding lug to the system ground of the premises wiring system. Use a properly sized grounding conductor.
- Connect three-phase power to the input terminals of the HG7, L1, L2 & L3.
- Connect the output power terminals, of the HG7, T1, T2 & T3, to the input power terminals of the variable frequency drive.

# INTRODUCTION

## Maintenance and Service

### HG7 Harmonic Filter Reliability and Service Life

The HG7 has been designed to provide a service life that equals or exceeds the life of the variable speed drive. It has been thoroughly tested at the factory to assure that it will perform reliably from the time it is put into service. The following periodic maintenance is recommended to assure that the HG7 filter will always perform reliably and provide the expected service life.

#### Periodic Maintenance

<b>Warning</b> 	Only qualified electricians should carry out all electrical installation and maintenance work on the HG7 filter.  Disconnect all sources of power to the drive and HG7 before working on the equipment. Do not attempt any work on a powered HG7.
---	---

Check to see that the installation environment remains free from exposure to excessive dirt and contaminants. Refer to the *Pre-installation Planning* section of this manual.

Check to make sure that the enclosure ventilation openings are clean and unobstructed.

Clean the air filter in units that have filtered air inlets. Clean as often as necessary to prevent dirt build-up from impeding air flow.

Check the operation of the cooling fan.

Inspect the interior of the enclosure for signs of overheated components. Clean the interior of the enclosure whenever excess dirt has accumulated.

Check the integrity of all power and ground wiring connections.

#### Troubleshooting

<b>Warning</b> 	Only qualified electricians should carry out all electrical installation and maintenance work on the HG7 harmonic filter.  Disconnect all sources of power to the drive and HG7 before working on the equipment. Do not attempt any work on a powered HG7 harmonic filter.  The harmonic filter contains high voltages and capacitors. Wait at least five minutes after disconnecting power from the filter before you attempt to service the harmonic filter. Check for zero voltage between all terminals on the capacitors. Also, check for zero voltage between all phases of the line side of the fuses, Fu1(a)–Fu2(a)–Fu3(a). All setup, maintenance, and troubleshooting must be done by a qualified electrician. Failure to follow standard safety procedures may result in death or serious injury.
---	--

Note: when disconnecting wires from components and terminations, mark the wires to correspond to their component and terminal connection.

#### Reference Drawings

When troubleshooting, refer to the drawings provided for the specific equipment. Typical drawings are provided in this manual.

# INTRODUCTION

## Fuse Specifications

Table 1a through 1d list the specifications for the LC filter power circuit fuses in the HG7. Refer also to the drawings and other information shipped with the unit.

**Table 1a – Fuse Specifications for HG7 240 Volt Models**

HG7 Rating (kVar)	Power Circuit Fuse Ratings	
	Amps	Type
3	15	Class CC Bussmann type KTK-R or equivalent
3	15	
5	25	
6	25	
8	35	Class T Bussmann type JJS or equivalent
10	45	
15	60	
15	60	
20	80	
25	100	
30	125	

**Table 1b – Fuse Specifications for HG7 400 Volt Models**

HG7 Rating (kW)	Power Circuit Fuse Ratings	
	Amps	Type
4	5	Class CC Bussmann type KTK-R or equivalent
5	6	
7.5	7	
9.3	9	
11	12	
15	15	
18.5	25	
22	25	
30	30	Class T Bussmann type JJS or equivalent
37	35	
45	45	
55	60	
75	80	
90	90	
110	110	
132	150	
160	150	
200	200	
250	250	
315	300	
355	350	
400	400	
450	450	
500	500	
560	600	
630	600	

# INTRODUCTION

**Table 1c – Fuse Specifications for HG7 480 Volt Models**

HG7 Rating (kVar)	Power Circuit Fuse Ratings	
	Amps	Type
3	10	Class CC Bussmann type KTK-R or equivalent
5	15	
6	15	
10	30	
15	30	
20	40	Class T Bussmann type JJS or equivalent
25	50	
30	60	
40	80	
45	100	
60	125	
75	175	
90	200	
105	225	
120	250	
150	300	
180	400	
210	450	
240	500	
270	600	

**Table 1d – Fuse Specifications for HG7 600 Volt Models**

HG7 Rating (kVar)	Power Circuit Fuse Ratings	
	Amps	Type
5	10	Class CC Bussmann type KTK-R or equivalent
10	25	
15	30	
15	30	
20	35	Class T Bussmann type JJS or equivalent
25	40	
30	50	
40	70	
45	80	
60	100	
75	125	
90	150	
105	175	
120	200	
150	250	
150	250	
180	300	
210	350	
240	400	
270	450	

# INTRODUCTION

## **Replacement Parts**

If replacement parts are needed, please contact your TCI representative. To ensure that the HG7 harmonic filter continues to perform to its original specifications, replacement parts should conform to TCI specifications.

## **Factory Contacts and Tech Support**

For technical support, contact your local TCI distributor or sales representative.

You can contact TCI directly at 800-TCI-8282. Select "Customer Service" or "Tech Support" and have your HG7 harmonic filter nameplate information available.

# INTRODUCTION

## Product Description

### HG7 Drive-Applied Harmonic Filter

The HG7 is a drive-applied harmonic filter designed and developed by TCI to reduce the harmonic currents drawn from the power source by variable speed drives. The HG7 is available for 240, 480, 600 (60 Hz) and 400 (50 Hz) volt systems. It is suitable for use with 3-phase diode bridge rectifier loads such as PWM AC drives.

The HG7 is a passive filter connected in series with the input terminals of a variable speed drive or several drives that operate as a group. It is designed to provide a low impedance path for the major harmonic currents demanded by the drive. The filter is a stand-alone device that can be furnished in its own enclosure and mounted adjacent to the drive. It is also available on an open panel for mounting within an enclosure with the drive or other equipment.

The HG7 filters consist minimally of the following features and components:

- ◆ A KDR input series reactor to prevent system interaction and improve filter performance.
- ◆ An L-C harmonic filter circuit with:
  - A TCI 3-phase tuning reactor specifically designed for the HG7 filter
  - High-endurance, harmonic-rated capacitors
- ◆ Bleeder resistors to ensure safe capacitor discharge upon filter shutdown.
- ◆ Cooling fans (on select models) to ensure adequate cooling and safe operating temperatures.
- ◆ Compression terminals for ease and integrity of all power and control wiring.
- ◆ Fuses to protect caps from over-current

### Nameplate Data

Figure 1 shows a typical HG7 harmonic filter nameplate. The following information is marked on the nameplate:

- ◆ Part number: encoding is explained on the following page
- ◆ FLA: the rated continuous operating current (RMS amps)
- ◆ System Voltage: the rated 3-phase line voltage (RMS volts)
- ◆ Hz: the rated frequency (60 Hz/50 Hz)
- ◆ Phase: 3 – The HG7 filter is designed for use only with 3-phase power.
- ◆ Drawing #: outline and mounting dimension drawing number
- ◆ Schematic #: schematic diagram drawing number
- ◆ Manufacturing #: for TCI internal use
- ◆ Enclosure Type: UL designation or "Open" panel construction

Figure 1 – Typical HG7 Harmonic Filter Nameplate

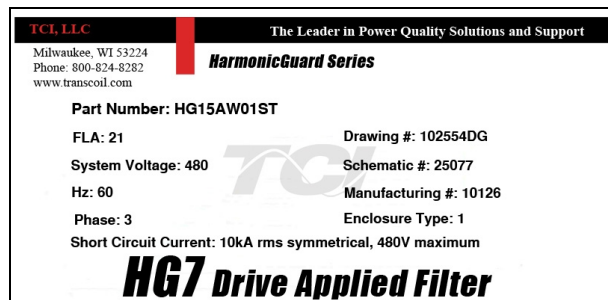



# INTRODUCTION

## Part Number Encoding

Figure 2 identifies the significance of each character in the HG7 part number. The example part number, HG250AW00ST designates a HG7 filter that is rated 75 kVar, 480 volts, 60 Hz. It includes the standard 10% reactor, is tuned to the 5th harmonic, is an open panel and is designed for use with a 250 Hp drive.

Figure 2 – HG7 Part Number Encoding

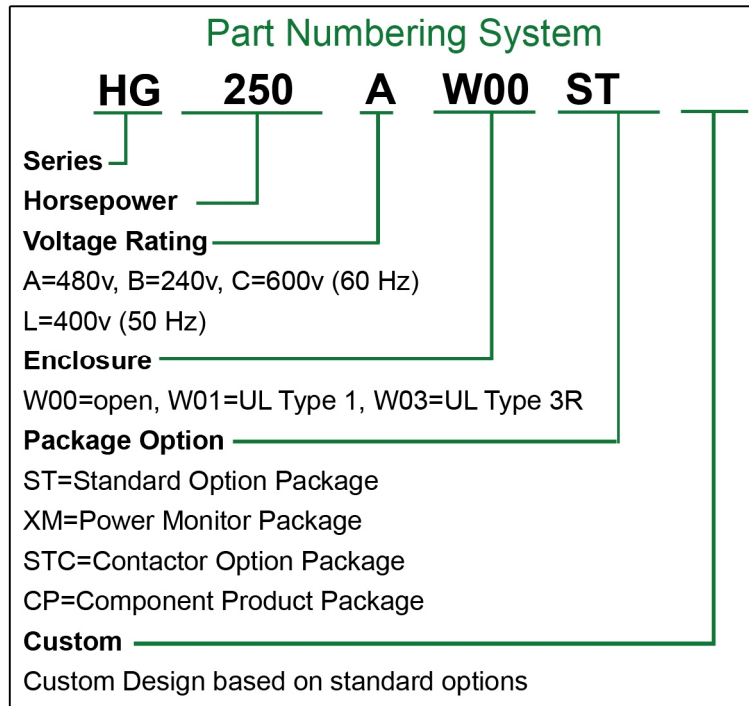

# INTRODUCTION

## Product Technical Specifications

Table 2 lists the major technical specifications for the HG7 Harmonic Filter.

**Table 2 – HG7 ST and STC Option Harmonic Filter Technical Specifications**

Voltage ratings	240, 480 and 600 V, 3 ph, 60 Hz 400 V, 3 ph, 50 Hz
kVar ratings	3 to 270 kVar depending on voltage. See Rating and Dimension tables.
Load types	3-phase diode bridge rectifier loads such as PWM AC drives
Load power range	7.5 -900 Hp depending on voltage. See Rating and Dimension tables.
Current ratings	The included series reactors can tolerate 200% of rated current for at least 3 minutes.
SCCR (short circuit current rating)	Standard rating is 10kA.
Maximum elevation	3,000 feet (1,000 meters) as standard.
Maximum ambient operating temperature	50°C (122°F) – Open Panel; 40°C (104°F) – Enclosed Panel. Product must be equipped with special cooling provisions for operation above this temperature.
Maximum ambient storage temperature	60°C (140°F)
Maximum humidity, operating or storage	95%, non-condensing.
Enclosure options	UL Type 1 enclosure UL Type 3R enclosure
Agency approvals or certifications	 UL and cUL Listed to UL508A
Insertion Impedance	+/- 10% at full load current
Fusing and protection:	All units have internal fuse protection for the harmonic filter circuit.
Capacitors	Oil filled high endurance design (no PCBs)

# INTRODUCTION

## Drawings

### Typical Schematic Diagrams and Outline and Mounting Dimension Drawings

Typical HG7 drawings are provided on the following pages. These drawings provide general information describing your HG7 harmonic filter. More specific information is provided by the drawings shipped with the unit. Be sure to carefully review the information on the provided drawings. The information on the drawings provided with the filter takes precedence over the information provided in this manual.

#### *Schematic Diagrams*

The schematic diagram shows the details of the HG7 circuitry. The power circuit schematic shows the variations in input and output power connections.

#### *Outline and Mounting Dimension Drawings*

Outline and mounting dimension drawings show the overall enclosure dimensions, the conduit access areas and the wiring connection points. The major internal components are shown pictorially.

#### *Additional Typical Drawings*

Some additional typical drawings are available for downloading at <http://www.transcoil.com>.

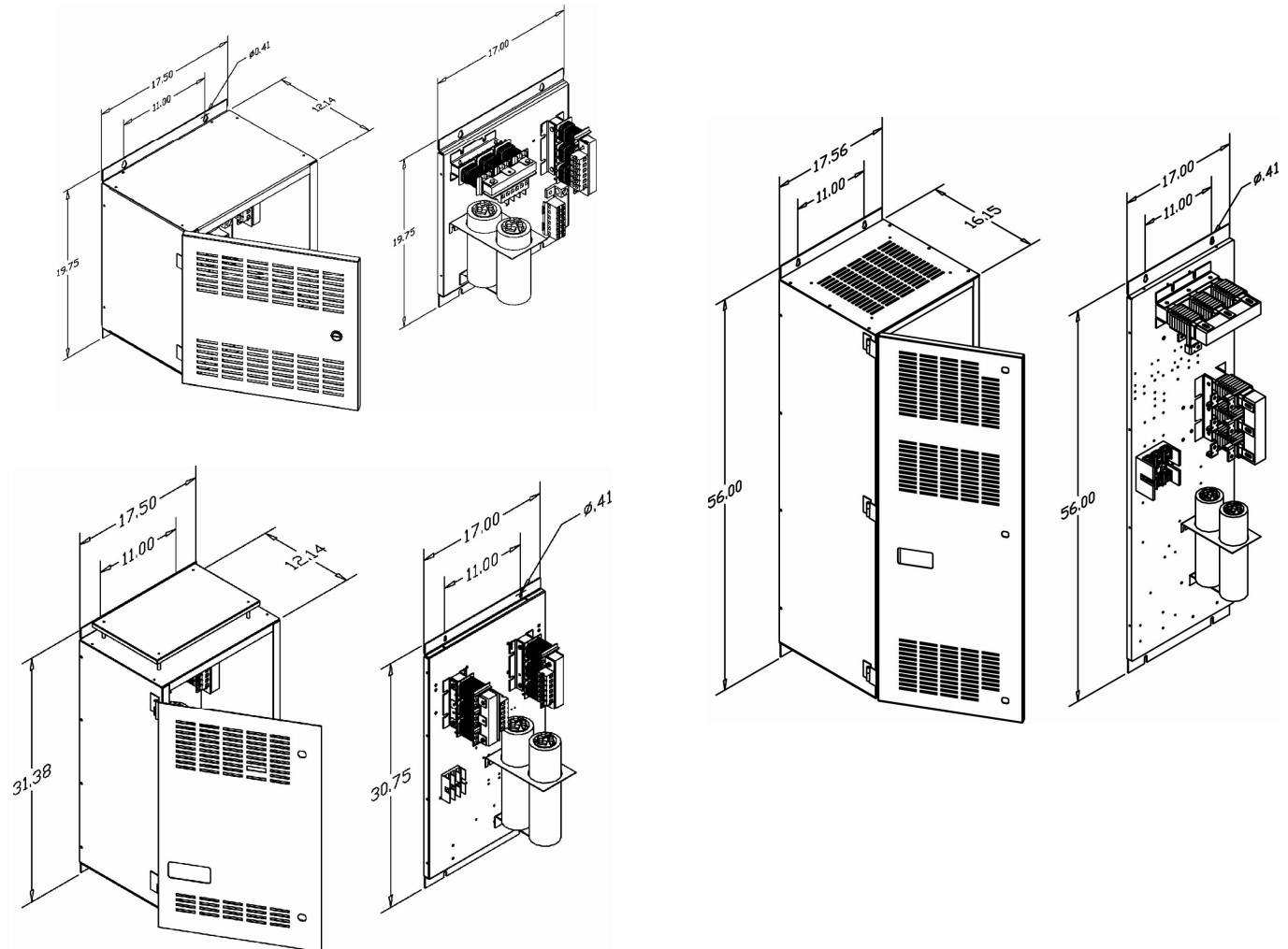

# INTRODUCTION

## Typical Drawings continued

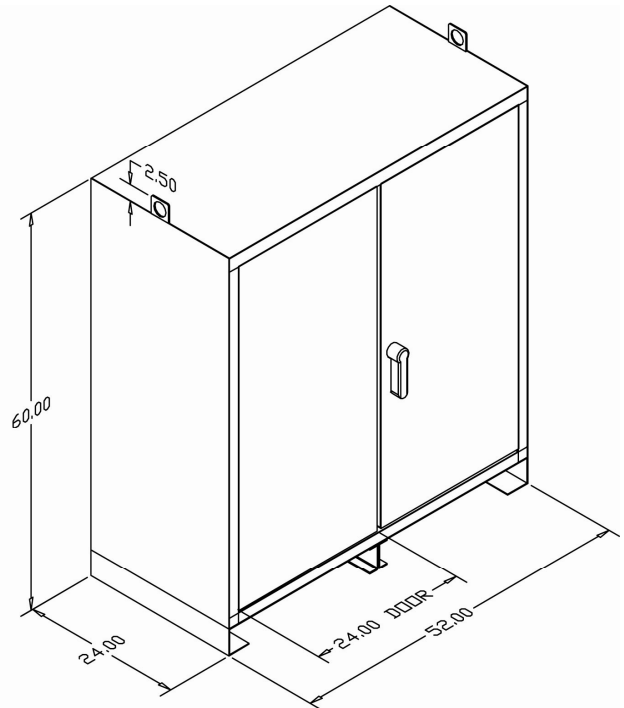
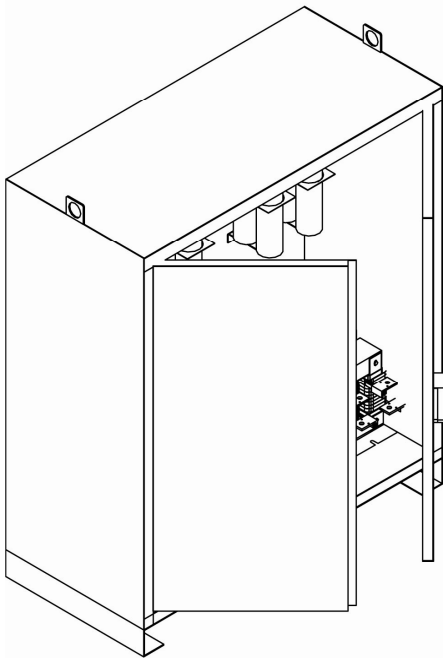
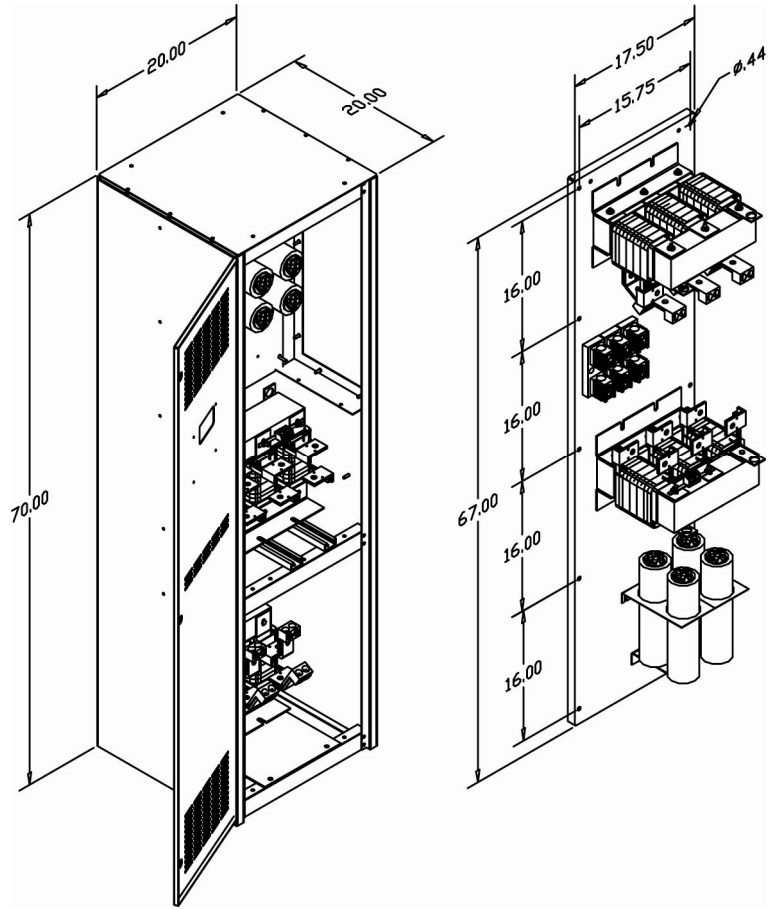

# INTRODUCTION

## HG7 ST Schematic

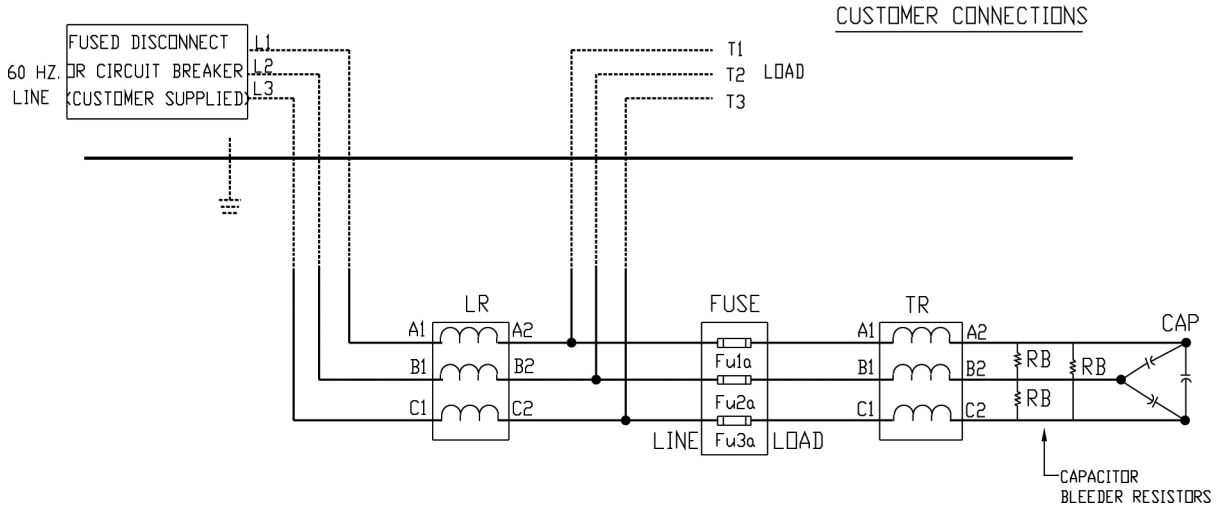

## HG7 STC Schematic

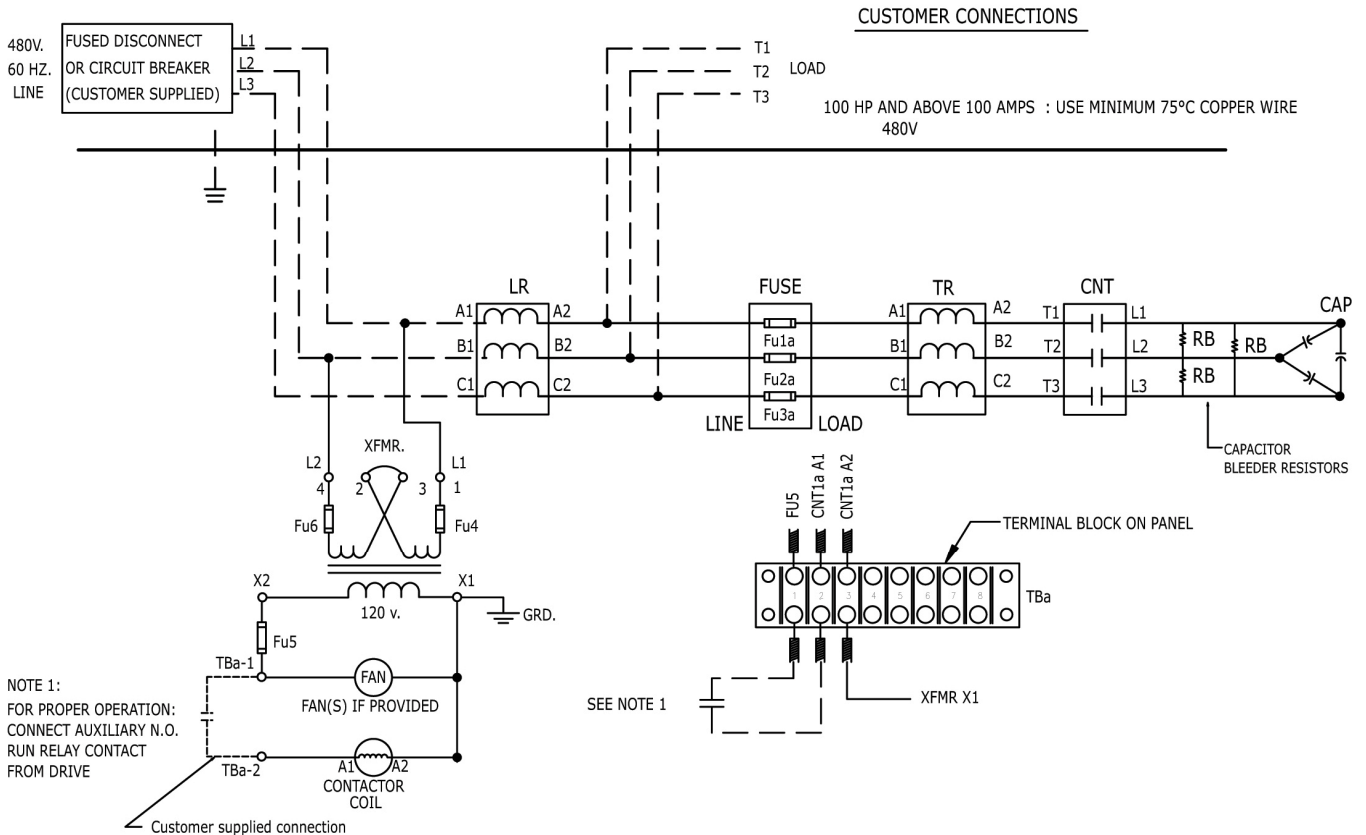

# INTRODUCTION

## HG7 XM Schematic: 7.5 – 60 HP based on 480V

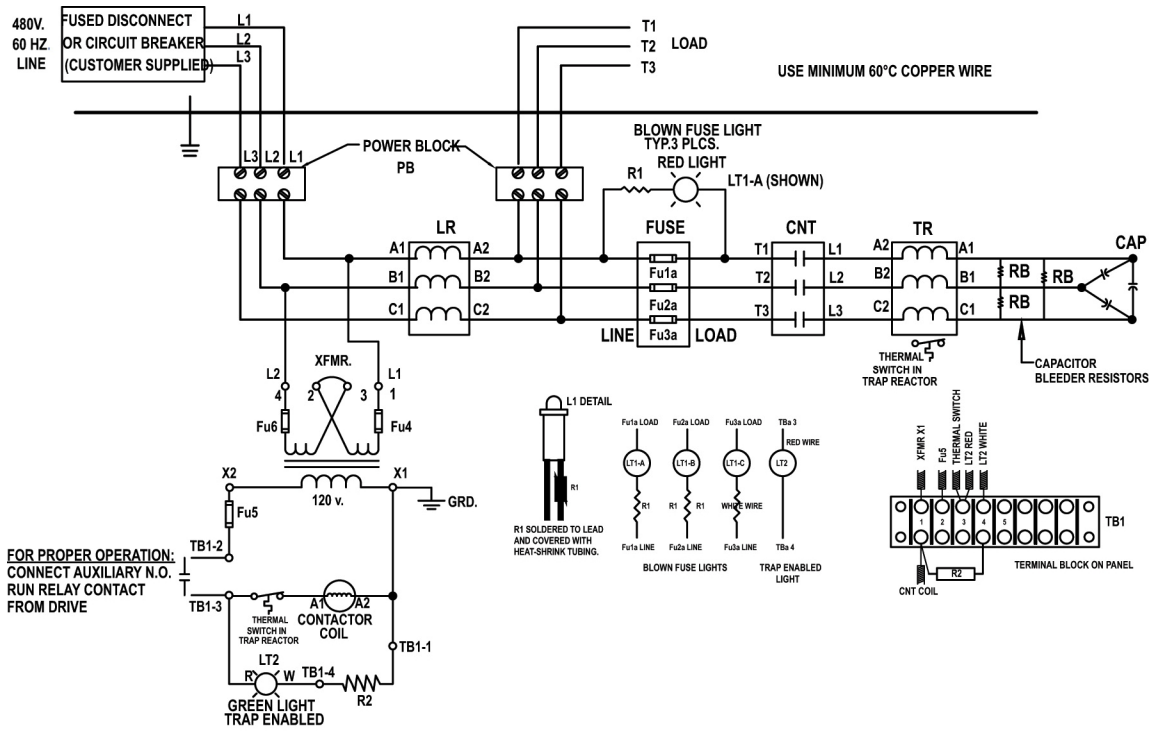

## HG7 XM Schematic: 200 – 400 HP based on 480V

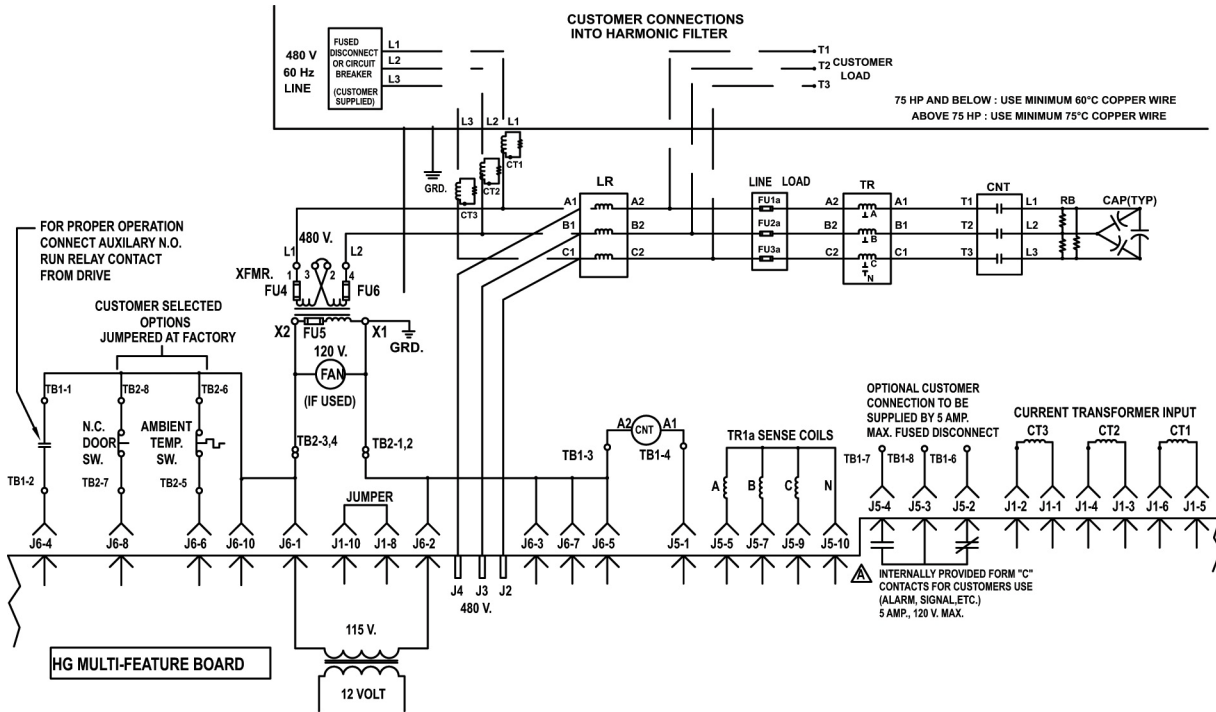

# INTRODUCTION

## HG7 XM Schematic: 450 – 600 HP based on 480V

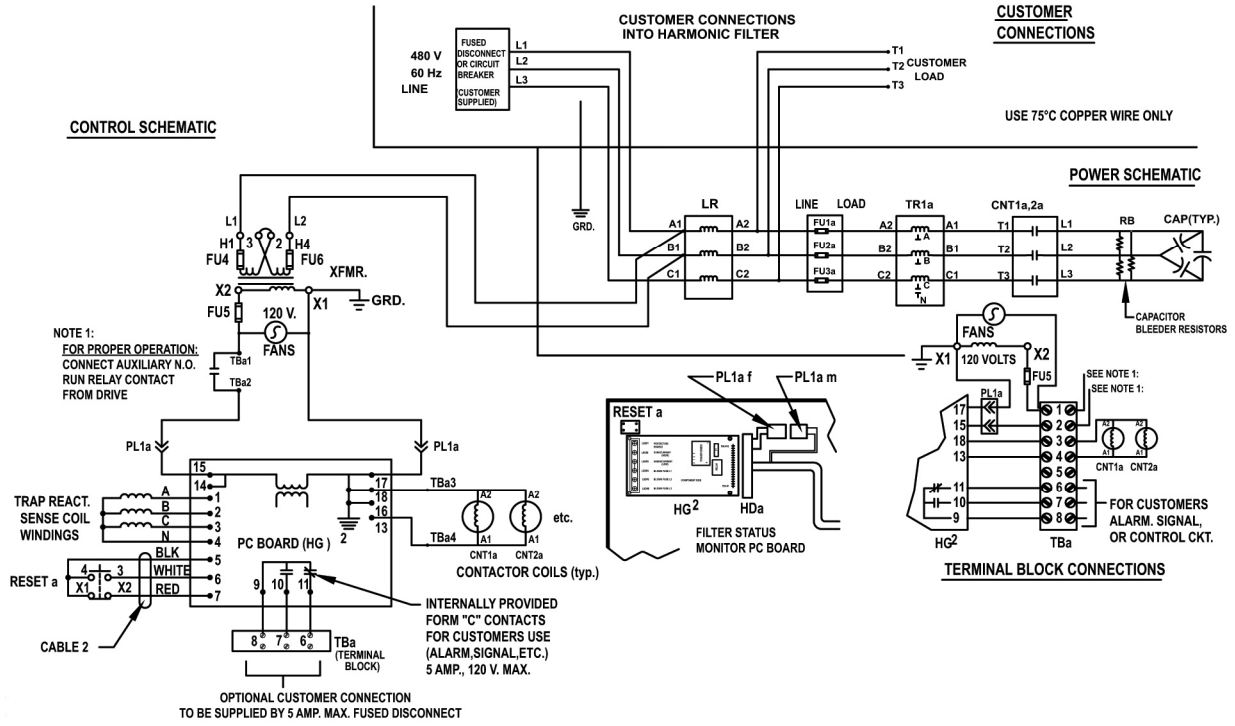





## Standard Filter (ST)

The Standard Package has the suffix of “ST” in the part number and includes everything necessary for an application to meet IEEE 519 standards. From the highest quality harmonic-grade capacitors on the market to the extraordinary reactors, this filter will meet the majority of application requirements found today. This cost effective product is available as either an open panel version or in a UL Type 1 enclosure. The open panel is perfect for inclusion in a MCC section or easy installation into industry standard enclosures. The UL Type 1 enclosed units maintain the same vertical profile as the open panel design. This design is perfect for applications where floor space is at a premium.

## Product Description

### HG7 Standard Harmonic Filter

The HG7 harmonic filter is a drive-applied harmonic filter designed and developed by TCI to reduce the harmonic currents drawn from the power source by variable speed drives. The HG7 Standard harmonic filter is for 200/208, 230/240, 460/480 volt and 575/600 volt systems (60 Hz) and 400 Volt systems (50 Hz). It is suitable for use with 3-phase diode bridge rectifier loads such as PWM AC drives and 3-phase controlled rectifier (SCR or thyristor) loads such as DC drives.

The HG7 harmonic filter is a passive filter connected in series with the input terminals of a variable speed drive or several drives that operate as a group. It is designed to provide a low impedance path for the major harmonic currents demanded by the drive. The filter is a stand-alone device that can be furnished in its own enclosure and mounted adjacent to the drive. It is also available on an open panel for mounting within an enclosure with the drive or other equipment.

The HG7 Standard consists of the following standard features and components.

- ◆ A KDR input series reactor to prevent system interaction and improve filter performance.
- ◆ An L-C harmonic filter circuit with:
  - A TCI 3-phase tuning reactor specifically designed for the HG7
  - High-endurance, harmonic-rated capacitors
- ◆ Bleeder resistors to ensure safe capacitor discharge upon filter shutdown.
- ◆ Cooling fans (on select models) to ensure adequate cooling and safe operating temperatures.
- ◆ Control Power transformer on enclosed units requiring auxiliary cooling fans.
- ◆ Compression terminals for ease and integrity of all power and control wiring.
- ◆ Fuses

## Contactactor Option (STC)

### STC Option Models

This model is identified by the suffix “STC” in the part number. The STC version provides a contactor, control power transformer and connection terminals in the filter trap circuit which allows the VFD user to control the use of the HG7 filter’s trap circuit. Simply use the drive relay run contact provided with the VFD to enable and disable the trap circuit. This virtually eliminates the possibility of leading power factor interacting with other devices on the power system and enables the user to perform trap circuit maintenance without shutting down the entire drive system.

## Product Description

### HG7 STC Option Harmonic Filter

The HG7 harmonic filter is a drive-applied harmonic filter designed and developed by TCI to reduce the harmonic currents drawn from the power source by variable speed drives. The HG7 STC option harmonic filter is for 200/208, 230/240, 460/480 volt and 575/600 volt systems (60 Hz) and 400 Volt systems (50 Hz). It is suitable for use with 3-phase diode bridge rectifier loads such as PWM AC drives and 3-phase controlled rectifier (SCR or thyristor) loads such as DC drives.

The HG7 harmonic filter is a passive filter connected in series with the input terminals of a variable speed drive or several drives that operate as a group. It is designed to provide a low impedance path for the major harmonic currents demanded by the drive. The filter is a stand-alone device that can be furnished in its own enclosure and mounted adjacent to the drive. It is also available on an open panel for mounting within an enclosure with the drive or other equipment.

The HG7 STC Option consists of the following standard features and components.

- ◆ A KDR input series reactor to prevent system interaction and improve filter performance.
- ◆ An L-C harmonic filter circuit with:
  - A TCI 3-phase tuning reactor specifically designed for the HG7
  - High-endurance, harmonic-rated capacitors
- ◆ Bleeder resistors to ensure safe capacitor discharge upon filter shutdown.
- ◆ Filter enable/disable contactor with protection and drive interlock provisions.
- ◆ Cooling fans (on select models) to ensure adequate cooling and safe operating temperatures.
- ◆ Control transformer for fan and control voltage power
- ◆ Compression terminals for ease and integrity of all power and control wiring.

## Power Monitor Package Option (XM)

This model is identified by the suffix “XM” in the part number. The “XM” Option HG7 filters are similar to the standard series HG7, but they have features and characteristics that are beyond the scope of the “Standard” series HG7. In the rating and dimension tables we list the sizes of the “XM” option units only to avoid confusion. This manual is intended to be used as a general guide to the installation, operation, and maintenance of “XM” Option filters.

## Product Description

### HG7 “XM” Option Harmonic Filter

The HG7 harmonic filter is a drive-applied harmonic filter designed and developed by TCI to reduce the harmonic currents drawn from the power source by variable speed drives. The HG7 “XM” option harmonic filter is for 200/208, 230/240, 460/480 volt, 575/600 volt systems (60 Hz) and 400 volt systems (50 Hz). It is suitable for use with 3-phase diode bridge rectifier loads such as PWM AC drives and 3-phase controlled rectifier (SCR or thyristor) loads such as DC drives.

The HG7 harmonic filter is a passive filter connected in series with the input terminals of a variable speed drive or several drives that operate as a group. It is designed to provide a low impedance path for the major harmonic currents demanded by the drive. The filter is a stand-alone device that can be furnished in its own enclosure and mounted adjacent to the drive. It is also available on an open panel for mounting within an enclosure with the drive or other equipment.

The HG7 “XM” Option consists of the following standard features and components.

- ◆ A KDR input series reactor to prevent system interaction and improve filter performance.
- ◆ An L-C harmonic filter circuit with:
  - A TCI 3-phase tuning reactor specifically designed for the HG7
  - High-endurance, harmonic-rated capacitors
- ◆ Bleeder resistors to ensure safe capacitor discharge upon filter shutdown.
- ◆ Filter enable/disable contactor with protection and drive interlock provisions.
- ◆ The HG2™ Protection Monitor and Harmonic Power Factor Meter is included as standard in HG7 “XM” option filters rated over 20kVar to 120 kVar in capacitance. It includes:
  - Three-character LCD display
  - Filter Disabled* and *Filter Enabled* status indicating LEDs
  - UP*, *DOWN*, and *SELECT* keys
  - Fault Alarm Relay* with form C contact for customer use
- ◆ *Filter Enabled* and *Blown Fuse* indicating lights are included as standard in filters rated 20 kVar and under, or over 120 kVA in filter capacitance rating.
- ◆ Cooling fans (on select models) to ensure adequate cooling and safe operating temperatures.
- ◆ Control transformer for fan and control voltage power
- ◆ Compression terminals for ease and integrity of all power and control wiring.

# POWER MONITOR PACKAGE ONLY

## Product Technical Specifications

Table 3 lists the major technical specifications for the HG7 “XM” Option filter product:

**Table 3 – HG7 “XM” Option Harmonic Filter Technical Specifications**

Voltage ratings	240, 480 and 600 V, 3 ph, 60 Hz 400 V, 3 ph, 50 Hz
kVar ratings	3 to 120 kVar, 140 to 270 kVar depending on voltage. See Rating and Dimension tables.
Load types	3-phase diode bridge rectifier loads such as PWM AC drives
Load power range	7.5 - 400 HP, 500 - 900 Hp depending on voltage. See Rating and Dimension tables.
Current ratings	The included series reactors can tolerate 200% of rated current for at least 3 minutes.
SCCR (short circuit current rating)	Standard rating is 10kA.
Maximum elevation	3,000 feet (1,000 meters) as standard. Product must be equipped with special cooling provisions for operation above this altitude.
Maximum ambient operating temperature	50°C (122°F) – Open Panel; 40°C (104°F) – Enclosed Panel. Product must be equipped with special cooling provisions for operation above this temperature.
Maximum ambient storage temperature	60°C (140°F)
Maximum humidity, operating or storage	95%, non-condensing.
Enclosure options	Standard: UL Type 1 enclosure
Agency approvals or certifications	 UL and cUL Listed to UL508A and CSA-C2.2 No. 14
Insertion Impedance	+/- 10% at full load current
Fusing and protection:	All units have internal fuse protection for the harmonic filter. HG2 Protection Monitor is standard in units rated over 20 kVar.
LCD display (units with HG2 Monitor)	<i>Operating Parameter</i> values: kW, kVA, power factor, voltage, current, harmonic voltage, current, and total harmonic distortion Faults: low current trip, high current trip, time delay over-current trip, door interlock, over-temperature, multi-unit external, and interlock faults. <i>Setup Parameters</i> : filter nameplate ratings, fault & reset delays, and trip levels.
Status indication LEDs (units with HG2 Monitor)	Green LED indicates: <i>Filter Enabled</i> Red LED indicates: <i>Filter Disabled</i>
Fault relay (units with HG2 Monitor)	De-energized when a fault is detected. Form C contact for customer use; rated 5 A at 120 VAC & 5 VDC.
Pilot lights (Units w/o HG2 monitor)	<i>Blown Fuse</i> indicating lights for 3-phase filter fuses <i>Filter Enabled</i> pilot light
Capacitors	Oil filled high endurance design (no PCBs)

## POWER MONITOR PACKAGE ONLY

### Control Wiring

#### *Control Power*

An internal control power transformer is provided to supply 120 VAC single-phase power for the contactor, Protection Monitor, and cooling fan(s). Fuses are provided on both the primary and secondary sides of the control transformer.

#### *Filter Enable Input*

An auxiliary N.O. run contact from the drive should be connected to the *Filter Enable* input to enable the HG7 “XM” Option only when the drive is running.

#### *Fault Alarm Relay*

A *Fault Alarm* relay is included in the HG2 Protection Monitor which is furnished as standard in “XM” Option units rated over 20 kVar. The *Fault Alarm* relay is energized when control power is applied to the HG7 and the HG7 is operating properly. A set of form C contacts is provided for customer use.

Determine how the *Fault Alarm* contact will be used. It may be connected to the drive external fault input or to some supervisory control or alarm annunciation equipment. A HG7 fault alarm indicates that the HG7 filter has been disabled by the HG2 Protection Monitor. If the drive operates while the HG7 is disabled, increased harmonic distortion of the power source may have adverse effects on the power distribution system components and other equipment. To guard against the effects of increased harmonic distortion, consider connecting the HG7 to automatically shut down the drive if a fault occurs. The best alternative to shutting down the drive is to provide an alarm to personnel who will promptly investigate the problem.

# POWER MONITOR PACKAGE ONLY

## Connection Diagram

Figure 3 shows the typical wiring connections between the HG7 and the drive. Refer to the drawings furnished with the HG7 for more specific information. Refer also to the instructions for the drive and other equipment to which the Enable Input and the Fault Alarm contact are connected.

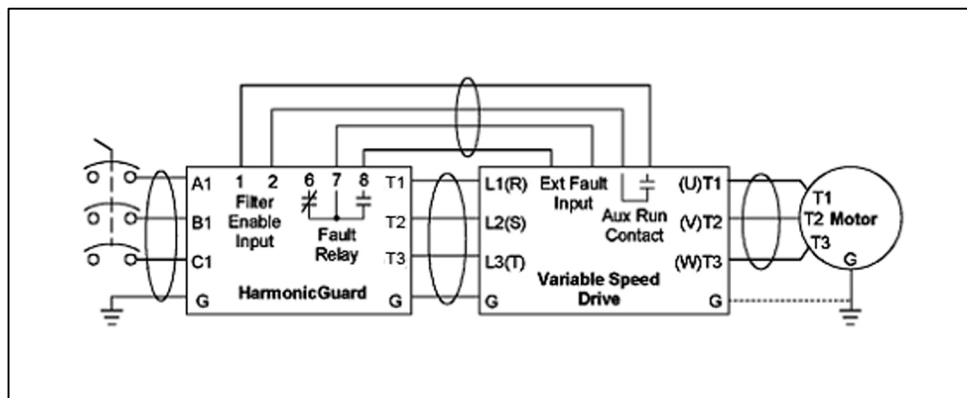

Figure 3 – Typical Connection Diagram

### For HG7 Harmonic Filters with the “XM” Option:

When connecting input power conductors directly to the input line reactors in the HG7 “XM” Option units, the conductors must be passed through the current transformers that are provided for use by the HG2 Protection Monitor. Units below 75 kVar and above 120 kVar do not have current transformers.

### Control Wiring

Connect the HG7 “XM” Option *Filter Enable* input (terminals 1 and 2) to an auxiliary N.O. Run contact in the adjustable speed drive. Connecting a *Drive Aux Run* contact will automatically connect the HG7 whenever the drive is running. If a jumper is connected between terminals 1 and 2, the HG7 will be connected whenever the drive branch circuit power disconnect device is closed. Connect the HG7 *Fault Alarm* relay contacts to the appropriate fault monitoring circuit. It may be connected to the drive or to some supervisory control or alarm annunciation equipment. The fault contact is part of the HG2 Protection Monitor, which is provided as standard in HG7 “XM” Option units larger than 20 kVar.

## HG7 “XM” Option Operation

### Adjustments

#### *Protection Monitor Settings*

- ◆ The Protection Monitor *Setup Parameters* and calibration adjustments are factory set and should not be changed except as directed in the troubleshooting procedures.
- ◆ The protection monitor is described in detail in the following section of this manual.

### Start Up (Commissioning)

<b>Caution</b>	Thoroughly check the installation before applying power and operating the equipment for the first time.
----------------	---

#### *Before Applying Power for the First Time*

Inspect the installation to make sure that all equipment has been completely and correctly installed on accordance with the *Installation Guidelines* section of this manual.

#### *Before Operating the Drive for the First Time*

- ◆ For units equipped with the HG2 Protection Monitor, check to see that the HG2 operates as described in the *HG2 Power Up Sequence*
- ◆ For units equipped with pilot lights, the *Blown Fuse* lights should be off. The *Filter Enabled* light should be off unless the Enable Input has been jumpered rather than connected to a *Drive Aux Run* contact.
- ◆ Check to see that the cooling fan(s) are operating in units so equipped.

## POWER MONITOR PACKAGE ONLY

# The HG2™ Protection Monitor

### Introduction

#### *Product Description*

The HG2™ Protection Monitor is included as standard in HG7 “XM” Option models rated over 20 kVar. The HG2 monitors the HG7 operation, electronically protects the power circuits, displays performance information, and provides a control interface with the drive and/or supervisory control system. A three-character display is provided with *UP*, *DOWN*, and *SELECT* keys and two status-indicating LEDs.

The HG2 includes analog inputs for monitoring the line voltage and current and the current in the harmonic filter. Current transformers are included in HG7, “XM” Option harmonic filter units to provide the line current inputs. Sense windings from in the tuning reactor provide the source for the current measurements. Voltage is measured through direct input to the HG2.

The HG2 Protection Monitor provides a local display for power monitoring at the point where the HG7 filter is connected to the power distribution system. The power monitoring display selections include line voltage, current, real power (kW), apparent power (kVA), power factor, and harmonic distortion parameters. The harmonic distortion parameters include total harmonic distortion (%THD) of the line voltage and current as well as individual values of low order harmonics. Filter current and harmonic values are also available. Three-phase average parameter values, totals, and individual phase values are available. The HG2 calculates parameter values from the signals available at the analog inputs.

The HG2 includes contact closure inputs for *Filter Enable* control and for optional *Over-temperature* and *Door Interlock* protection functions. A serial interlock connection is provided for coordinating the protection functions of multiple HG2 Protection Monitors.

The HG2 Protection Monitor provides fault protection for the filter by disconnecting the capacitor banks when a fault is detected. Protection functions include filter over and under-current, door interlock, over-temperature, and others. Note that the door interlock switch and the over-temperature thermostatic switch are optional. *Fault Codes* are generated on the display for ease of troubleshooting.



## POWER MONITOR PACKAGE ONLY

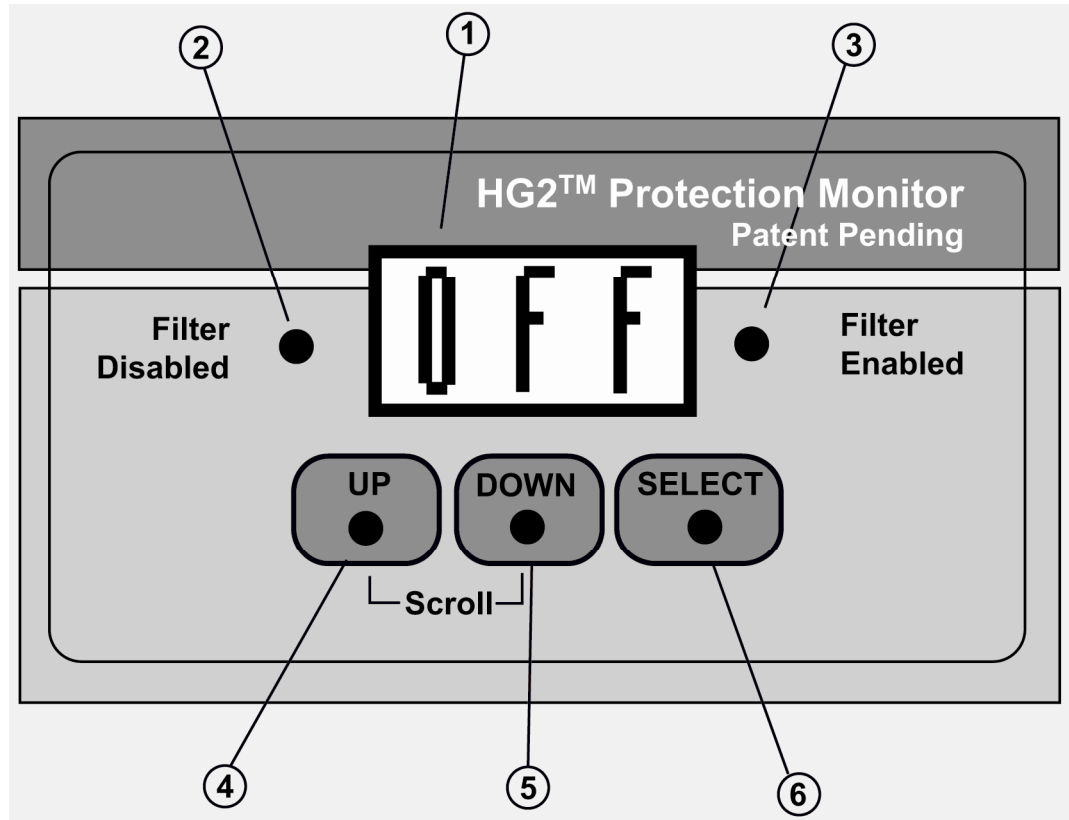

**Figure 4 – HG2 Protection Monitor Display and Keypad**

### *Display and Keypad*

Figure 4 shows the HG2 Protection Monitor display and keypad. Table 4 lists the various component items and describes their functions.

**Table 4 – HG2 Protection Monitor Display and Keypad Features**

Item No.	Name	Description	Function
1	Display	LCD	Displays “OFF” when filter is off. Displays the value of the selected <i>Operating Parameter</i> . Displays <i>Fault Code</i> (Fnn) when a fault condition exists.
2	<i>Filter Disabled</i>	Red LED	Illuminated when filter is disabled by fault trip.
3	<i>Filter Enabled</i>	Green LED	Illuminated when filter is operating.
4	<i>UP</i> (Scroll)	Key	Press and release quickly to display the name of the selected parameter. Display automatically reverts to parameter value display after 1 second. Press and hold to scroll to desired parameter selection.
5	<i>DOWN</i> (Scroll)	Key	
6	<i>SELECT</i>	Key	Press and release quickly to display L #, L A, or L r, phase, average, or total value selection. Press and hold to scroll to desired selection.

# POWER MONITOR PACKAGE ONLY

## General Operation

### Power Up Sequence

- ◆ For the first 3 seconds after power is applied the display will show “888.”
- ◆ After the first 3 seconds and until the reset lockout time (parameter 1A, 30 sec. Default) has expired, the display will show “OFF.”
- ◆ When the reset lockout time has expired:

If the *Enable* input is open and no fault exists:

The red *Filter Disabled* LED will be off.

The green *Filter Enabled* LED will be off.

The display will show “OFF.”

If the *Enable* input is open and there is an external, over-temperature, or serial data fault:

The red *Filter Disabled* LED will be on.

The *Fault Alarm* relay will be energized.

The green *Filter Enabled* LED will be off.

The display will show "F01," "F03," or "F04" for the respective faults.

If the *Enable* input is closed and no fault exists:

The red *Filter Disabled* LED will be off.

The green *Filter Enabled* LED will be on.

The contactor will pull in connecting the filter.

The display will show the value of the selected *Operating Parameter*.

If the *Enable* input is closed and a fault exists:

Initially, the green *Filter Enabled* LED will be on and the contactor will pull in connecting the filter until the fault is detected.

Once the fault is detected:

The red *Filter Disabled* LED will be on.

The *Fault Alarm* relay will be energized.

The green *Filter Enabled* LED will be off.

The display will show a *Fault Code*, F01 to F31.

### Normal Operation

The filter should operate whenever the drive operates. When the drive starts, a *Drive Aux Run* contact should close the HG7's *Filter Enable* input. After the reset lockout time has expired, the green *Filter Enabled* LED will turn on and the contactor in the HG7, “XM” Option will connect the filter. The display will show the value of the selected *Operating Parameter*.

When the drive stops, a *Drive Aux Run* contact should open the filter's *Enable* input. The green *Filter Enabled* LED will turn off and the contactor in the HG7 will disconnect the filter. The display will show "OFF."

### Changing the Displayed Parameter

During operation, the HG2 displays the value of the selected *Operating Parameter*. The *Operating Parameters* are listed in Table 5. When the *UP* or *DOWN* key is pressed and immediately released, the display shows the parameter name for approximately 1 second and then reverts to displaying the parameter value. To change to the next or previous parameter, press the *UP* or *DOWN* key and release the key as soon as the parameter name changes. Holding down the *UP* or *DOWN* keys will scroll through parameters forward or backward, respectively.

When the *SELECT* key is pressed and immediately released, the display shows "L 1," "L 2," "L 3," "L A," or "L r," for approximately 1 second and then reverts to displaying the parameter value. "L A,"

## POWER MONITOR PACKAGE ONLY

indicates that the displayed value is the average of the individual phase values. "L 1," "L 2," & "L 3" indicate the display of individual phase values. "L r," indicates that the displayed value is the total of the phase values. To change the "L \*" selection, press and hold the *SELECT* key to scroll to the desired selection. The "L 1," "L 2," & "L 3" selections are available for all of the parameters. The "L A" selection is available for *Filter Current* "C," *Line Voltage* "U," *Line Current* "A" and *Power Factor* "PF." The "L r" selection is available for *Real Power* "P" and *Apparent Power* "UA."

**Table 5 – Operating Parameter Display**

Parameter Name	Parameter Value	Parameter ID	Parameter Value
OFF	Not in run and no faults	A	Line Current (total RMS amps)
C	Filter current (total RMS amps)	A H	Line harmonic current distortion (% THD)
C H	Filter harmonic current distortion (% THD)	A 1	Line 1st harmonic current (fundamental RMS amps)
C 1	Filter 1st harmonic current (fundamental RMS amps)	A 5	Line 5th harmonic current (RMS amps)
C 5	Filter 5th harmonic current (RMS amps)	A 7	Line 7th harmonic current (RMS amps)
C 7	Filter 7th harmonic current (RMS amps)	A11	Line 11th harmonic current (RMS amps)
C11	Filter 11th harmonic current (RMS amps)	A13	Line 13th harmonic current (RMS amps)
C13	Filter 13th harmonic current (RMS amps)	P	Real Power (kW)
U	Line voltage L-N (total RMS volts) L-N approx. 277 for a 480 volt system and approx. 139 for a 240 volt system	U A	Apparent Power (kVA)
U H	Line harmonic voltage distortion (% THD)	PF	Power Factor (%)
U 1	Line 1st harmonic voltage (fundamental RMS volts)	*L A	Average value
U 5	Line 5th harmonic voltage (RMS volts)	*L r	Total value
U 7	Line 7th harmonic voltage (RMS volts)	*L 1	Line 1 value
U11	Line 11th harmonic voltage (RMS volts)	*L 2	Line 2 value
U13	Line 13th harmonic voltage (RMS volts)	*L 3	Line 3 value

\* These functions are accessible by pressing the *SELECT* key.

### *Fault Detection*

If a fault condition is detected by the HG2, the red *Filter Disabled* LED will turn on and the *Fault Alarm* relay will be energized. The green *Filter Enabled* LED will turn off and the contactor in the HG7 will disconnect the filter. The display will show a *Fault Code*, F001 to F31 as listed in Table 6. In order to minimize nuisance trips, time delays are applied to some fault conditions as indicated in the table.

When the fault condition has been corrected, press the *UP* and *SELECT* keys simultaneously to clear the fault. When the fault reset clear time has expired, the red *Filter Disabled* LED will turn off and the *Fault Alarm* relay will be de-energized. The green *Filter Enabled* LED will turn on, the contactor will connect the filter and the display to the selected *Operating Parameter*.

In a system with multiple units, any unit may detect a fault and shut down the whole system. The other units in the system will display "F01," External Fault, and turn off. The fault may only be cleared by

## POWER MONITOR PACKAGE ONLY

resetting the unit that detected the fault condition. The other units in the system will be clear automatically when the faulted unit is reset.

**Table 6 – Fault Code Display**

Fault Code	Fault Description
F01	External Fault (multiple boards in a series line)
F02	Door Open In Run Mode (no delay)
F03	Overtemp (6 sec. delay)
F04	Serial Data Fault (8 sec delay)
F11	Filter Current Low Trip Line 1 (20 sec. delay)
F12	Filter Current Low Trip Line 2 (20 sec. delay)
F13	Filter Current Low Trip Line 3 (20 sec. delay)
F21	Filter Overcurrent Fast Trip Line 1
F22	Filter Overcurrent Fast Trip Line 2
F23	Filter Overcurrent Fast Trip Line 3
F31	Filter Overcurrent Delayed Trip Line 1 (delay set by parameter 1A)
F32	Filter Overcurrent Delayed Trip Line 2 (delay set by parameter 1A)
F33	Filter Overcurrent Delayed Trip Line 3 (delay set by parameter 1A)

### Setup Parameters

#### Introduction

The *Setup Parameters* are used to enter the nameplate data required for matching the HG2 to the HG7 harmonic filter ratings. Fault trip levels and delay times are also adjustable. A security code can be entered to prevent unauthorized access to the *Setup Menu*. The *Calibration Mode* is accessible through the *Setup Menu* (See *HG2 Protection Monitor Calibration*). Table 7 describes the *Setup Parameters*, indicates the adjustment ranges, and lists the factory default settings. The Protection Monitor *Setup Parameters* and calibration adjustments are factory set and should not be changed except as directed in the troubleshooting procedures.

#### Setup Procedure

1. With the power off and no over-temperature fault condition, hold down all three keys (*UP*, *DOWN*, and *SELECT*) while applying power. Hold for 5 seconds after power is applied.
2. Release all three keys. The display will show "000".
3. If the security code has not been changed from the Factory Default of "000" go to step 5.
4. If the security code is not "000," press the *DOWN* key to enter the security code for digit one. Press the *UP* key once to select digit two. Press the *DOWN* key to enter the code for digit two. Press the *UP* key once to select digit three. Press the *DOWN* key to enter the code for digit three.
5. Press and release the *SELECT* key. The display will show "---" if the code is correct, or "OFF" if the code is not correct. If the incorrect code has been entered, start over at step 1.
6. Press and release the *UP* key. "1A" will be displayed.
7. Press and release the *SELECT* key to display the parameter setting.
8. When the setting of a selected parameter is displayed, pressing the *UP* and *DOWN* keys will increase and decrease the setting.
9. Press and release the *SELECT* key to store the setting and return to the menu.
10. Press and release the *UP* key to display the next parameter on the Setup Menu.
11. To exit setup, use the *UP* key to step through the menu past parameter "11A" to "---", then press the *SELECT* key.

## POWER MONITOR PACKAGE ONLY

12. You can step through the menu only in the "UP" direction. If you wish to return to an item once you have stepped past it, step past "---" without pressing the SELECT key to return to "1A."

**Table 7 – Setup Menu**

Parameter Name	Description	Range	Factory Default Setting
---	Enter/Exit Factory Setup Mode		
1 A	Fault Delay Time	1-60 SEC	30
2 A	Restart Lockout Time	1-60 SEC	30
3 A	Filter KVAR Rating (Nameplate)	3.0-120 KVAR	(Nameplate)
4 A	Operating Frequency (Nameplate)	50 or 60 Hz	(Nameplate)
5 A	Fast Trip Overcurrent % Set	100%-199%	180
6 A	Slow Trip Overcurrent % Set	100%-199%	160
7 A	Low Trip Undercurrent % Set	1%-100%	80
8 A	Nominal Line to Line Voltage (Nameplate)	200 - 600 VOLTS	(Nameplate)
9 A	Line Current Rating (Nameplate)	0 or 5 - 480 AMPS	(Nameplate)
10A	Security Code	000 – 999	000
11A	<i>Calibration Mode</i>	0 = Normal Operation 1 = Calibration Mode	0

### *Changing the Security Code*

The factory default security code is "000." To change this code, enter the *Setup Menu* and proceed as follows:

13. Use the *UP* key to step to parameter "10A."
14. Press and release the SELECT key. The present security code will be displayed.
15. Use the DOWN key to change digit one to the first digit of the new code.
16. Press the UP key once to select digit two.
17. Press the DOWN key to change digit two to the second digit of the new code.
18. Press the UP key once to select digit three.
19. Press the DOWN key to enter digit three to the third digit of the new code.
20. Press the UP key once and the original code will be displayed.
21. Repeat the steps 3 to 7 to enter the new code a second time.
22. After completing step 7, press the SELECT key.
23. If the new code has been properly entered twice, the display will show "10A" and the new code will be saved.
24. If the two entries of the new code did not agree, "err" will be displayed. Press any key and the display will show "10A." If you press and release the SELECT key, you can see that the code remains unchanged. You can start over at step 3.

<b>NOTE:</b>	If the code is changed and the new code is lost, you will no longer have access to the <i>Setup Menu</i> . The unit will have to be returned to the factory to be reprogrammed to the default security code.
--------------	--

# POWER MONITOR PACKAGE ONLY

## Troubleshooting Units Equipped with the HG2™ Protection Monitor

The HG2™ Protection Monitor and Harmonic Power Factor Meter is included as standard in HG7 “XM” option filters rated over 20 kVar. Units rated 20 kVar and less have *Blown Fuse* and *Filter Enabled* pilot lights to indicate their operating status and are not equipped with the HG2 as standard. Troubleshooting information for pilot light equipped units is provided in the following section under the heading *Troubleshooting Units Equipped with Pilot Lights*.

### Normal Operation

The normal operation of the HG2 protection monitor is described in detail in the *HG2 Protection Monitor* section of this manual. Refer also to *HG2 Protection Monitor Calibration* including figures 5, 6 and 7.

### Protection Monitor Display and Status Lights

During *Normal Operation*, the green *Filter Enabled* LED should be on, the red *Filter Disabled* LED should be off and the display should show the selected *Operating Parameter*.

### If the HG2 display is blank and no LEDs are illuminated, the possible causes include:

- ◆ If the drive is also inoperable and lacking any "Power On" indications:
  - Three-phase power has probably been disconnected either manually or by the operation of a protective device. Check the main disconnect and fuses or circuit breaker. If fuses have blown or a breaker has tripped, a short circuit or severe overload condition has probably occurred in the HG7 filter, drive, motor, or power wiring. Check for evidence of damaged, burned, or overheated wiring or components.
- ◆ If the drive appears to be receiving power:
  - Check the primary and secondary control power transformer fuses in the HG7 filter.
    - If a fuse has blown**, there is probably a short circuit, ground fault, or overload condition in the HG7. Check for evidence of damaged, burned, or overheated wiring or components.
    - Check the following items:
      - Control circuit wiring
      - Control circuit transformer
      - Cooling fan
      - HG2 Protection Monitor
    - If the fuses are good**, the HG2 may be defective

### If drive is operating but the HG2 display shows OFF, the red *Filter Disabled* LED is on and the green *Filter Enabled* LED is off:

- ◆ Check the *Filter Enable* input to the HG2.
  - If the *Filter Enable* input is open, the *Drive Aux Run* contact may be open or disconnected.
  - If the *Filter Enable* input is closed, the HG2 may be defective.

# POWER MONITOR PACKAGE ONLY

## Protection Monitor Display Fault Codes

If the Protection Monitor display shows a *Fault Code* (F01 to F33), follow the troubleshooting procedure provided in Table 8. If a *Fault Code* is displayed, the *Filter Disabled* LED will be illuminated and the *Fault Alarm Relay* will be de-energized.

**Table 8 – Fault Code Troubleshooting Procedures**

FAULT Code	Troubleshooting Procedure
<p><b>F01</b></p>	<p><b>External Fault</b>            This <i>Fault Code</i> indicates a fault in an HG7unit other than the one displaying the "F01" <i>Fault Code</i>.</p> <p>In a system that has multiple sections, each monitored with an HG2, any HG2 may detect a fault and in turn disconnect all the harmonic filters linked via the serial connection. The unit detecting the fault will display the appropriate <i>Fault Code</i> while all others in the series will display "F01." The fault may only be cleared from the harmonic filter section experiencing the fault. Once the fault is cleared the other units will revert to <i>Normal Operation</i>. In single board configurations, there is a jumper wire installed in connector J1-8 &amp; J1-10. Troubleshoot by verifying continuity at the Protection Monitor between J1-8 &amp; J1-10.</p>
<p><b>F02</b></p>	<p><b>Door Interlock Fault</b>            This <i>Fault Code</i> indicates the optional door interlock switch is open.</p> <p>When this option is not supplied there is a jumper wire installed between TB2-7 &amp; TB2-8. Troubleshoot by verifying continuity between J6-1 &amp; J6-8.</p>
<p><b>F03</b></p>	<p><b>Over-temperature Fault</b>            This <i>Fault Code</i> indicates the optional over temperature switch open.</p> <p>When this option is not supplied there is a jumper wire installed between TB2-5 &amp; TB2-6. Troubleshoot by verifying continuity at the Protection Monitor between J6-1 &amp; J6-6.</p>
<p><b>F04</b></p>	<p><b>Serial Interlock Fault</b>            This fault indicates the serial link between multiple boards is open or wired incorrectly.</p> <p>Verify that from board number one J1-8 is connected to board two J1-10 and board two J1-8 to board "N" J1-10 and board "N" J1-8 is connected to board one J1-10 thus completing the daisy chain serial loop. In single board configurations, there is a jumper wire installed in connector J1-8 &amp; J1-10. Trouble shoot by verifying continuity at the Protection Monitor between J1-8 &amp; J1-10.</p>

## POWER MONITOR PACKAGE ONLY

FAULT Code	Troubleshooting Procedure
<b>F11-F13 Fault on initial startup</b>	<p><b>Filter Current Low Trip</b></p> <p>If the F11, F12 or F13 fault occurred upon initial startup (commissioning), use this procedure. <b>If the unit had been operating normally for some time after initial startup (commissioning), refer to the next section.</b></p> <p>This fault indicates the filter current is lower than normal. Fault F11 indicates low current through fuse Fu1(a), F12 indicates low current through fuse Fu2(a) and F13 indicates low current through fuse Fu3(a).</p> <p>First check for any shipping damage. Look for loose connections, especially those associated with the HG2 board and fuses Fu1(a), Fu2(a) and Fu3(a). Make sure that Fu1(a), Fu2(a), and Fu3(a) are properly installed. Check for proper balanced line-to-line voltages on L1, L2, and L3.</p> <p>If there are no obvious errors in the wiring and installation of the filter go to the <i>Setup Procedure</i> page 34. Verify that all the parameters are correct for this installation. At this point leave the parameter 11A set to (0), exit the setup mode, and allow the filter to reenergize.</p> <p>If the F11 fault still appears, return to the <i>Setup Procedure</i> and set parameter 11A to (1). Upon exiting this time, the filter will re-energize in the <i>Calibration Mode</i>. <b>Caution! When in the Calibration Mode, the HG2 board will not de-energize the filter under fault conditions.</b> Follow the <i>Calibration Procedure</i> on page 42.</p> <p>The factory default setting for the <i>Filter Current Low Trip</i> (parameter 7A) is 80% of the filter's nominal fundamental current rating as determined by the filter's kVar, frequency, and voltage ratings (parameters 3A, 4a &amp; 8A). If the trip level is set below 80%, the HG2 may not trip when a partial loss of capacitance has occurred. If the trip level is set above 80%, the HG2 may trip unnecessarily. <b>It is recommended that the setting not be changed without consulting the technical support department at the factory.</b></p>



## POWER MONITOR PACKAGE ONLY

FAULT Code	Troubleshooting Procedure
<b>F11-F13 Fault after initial normal service</b>	<p><b>Filter Current Low Trip</b></p> <p>If the F11, F12, or F13, fault occurred after the unit had been operating normally for some time after initial startup (commissioning), use this procedure. <b>If the fault occurred upon initial startup (commissioning), refer to the previous section.</b></p> <p>If the unit operated normally after setup and calibration, the fault usually indicates a fuse cleared or a loss of capacitance occurred, thus lowering the normal current. Fault F11 is associated with fuse Fu1(a), F12 is associated with fuse Fu1(a), and F13 is associated with fuse Fu3(a). Check the fuses and replace any that have cleared with known good fuses of the same type and rating. Check for signs of a short circuit.</p> <p>Restart the filter and verify that the filter currents are at the proper levels. <b>Caution! Troubleshooting with the filter energized means there are hazardous voltages present. Only qualified personnel should do this service work.</b></p> <p>If the fuses are good, verify the integrity of the contactor. The electrical contacts are consumable wear parts and may need service.</p> <p>If the contactor is deemed in serviceable condition go to the <i>Setup Procedure</i> on page 34. Step through the parameters and set parameter 11A to (1), exit the setup mode, and allow the filter to reenergize in the <i>Calibration Mode</i>. <b>Caution! When in the Calibration Mode, the filter will not automatically disconnect upon recognizing a fault condition.</b> Measure currents; if lower than the percentage of nominal amount set in 7A, an F11 fault will result. It is usually an indication of loss of capacitance. To locate the faulty capacitor(s), first verify the proper line-to-line voltage is present at the terminals of each capacitor. If the voltage is correct, then measure the current into each individual capacitor. If any of the currents are lower than nameplate by greater than 10%, replace the defective capacitor(s), and verify proper operation.</p> <p>The factory default setting for the <i>Filter Current Low Trip</i> (parameter 7A) is 80% of the filter's nominal fundamental current rating the as determined by the filter's kVar, frequency, and voltage ratings (parameters 3A, 4a &amp; 8A). If the trip level is set below 80%, the HG2 may not trip when a partial loss of capacitance has occurred. If the trip level is set above 80%, the HG2 may trip unnecessarily. <b>It is recommended that the setting not be changed without consulting the technical support department at the factory.</b></p>

## POWER MONITOR PACKAGE ONLY

FAULT Code	Troubleshooting Procedure
F21-23	<p><b>Filter Over-current Fast Trip</b></p> <p>The usual causes for this fault are:</p> <ul style="list-style-type: none"> <li>Oversized drive for the capability of the filter.</li> <li>Excessive harmonics present on the distribution system from other sources.</li> <li>Partial loss of capacitance (thus causing the filter circuit tuning point to shift at or above the designed frequency).</li> <li>Line voltage is greater than 125% of the nominal rating.</li> <li>Interaction with power factor capacitors on the distribution system resulting in system resonance conditions.</li> </ul> <p>If F21-F23 faults occur repeatedly in the apparent absence of any of the above problems, verify the actual filter current with a current probe suited for true RMS measurements in a harmonic rich circuit. Note: It may be necessary to inhibit the board from de-energizing the filter by operating in the calibrate mode. However, be aware that if excessive currents are indeed present, the technician must be able to rapidly remove power from the filter to minimize damaging components or blowing the filter fuses.</p> <p>The factory default setting for the <i>Filter Over-current Fast Trip</i> (parameter 5A) is 180% of the filter's nominal fundamental current rating as determined by the HG7's kVar, frequency, and voltage ratings (parameters 3A, 4a &amp; 8A). If the trip level is set above 180%, the life of the capacitors may be reduced or the fuses may blow. If the trip level is set below 180%, the filter may trip unnecessarily. <b>It is recommended that the setting not be changed without consulting the technical support department at the factory.</b></p>

## POWER MONITOR PACKAGE ONLY

FAULT Code	Troubleshooting Procedure
<b>F31-F33</b>	<p><b>Filter Over-current Delayed Trip</b></p> <p>The usual causes for a F31 displayed fault are:</p> <ul style="list-style-type: none"> <li>Short-term operation above rated line current during acceleration of the load or other normal utilization of the drive's short-term overload capacity.</li> <li>Operation above rated line current due to abnormal drive overload condition.</li> <li>Excessive harmonics present on the distribution system from other sources.</li> <li>Partial loss of capacitance (thus causing the filter circuit tuning point to shift to or above the designed frequency).</li> <li>Line voltages greater than 125% of the nominal rating.</li> <li>Interaction with power factor capacitors on the distribution system resulting in system resonance conditions; however, not to the level that would cause a fast trip as indicated by the display of F2x fault.</li> </ul> <p>If the problem is caused by short-term (&lt;60 seconds) operation above rated line current due to normal utilization of the drive's short-term overload capacity, increasing the time to fault setup parameter (1A) may alleviate the problem.</p> <p>If F31-F33 faults occur repeatedly in the apparent absence of any of the above problems, verify the actual filter current with a current probe suited for true RMS measurements in a harmonic rich circuit. Note: It may be necessary to inhibit the board from de-energizing the HG7 by operating in the calibrate mode. However, be aware that if excessive currents are indeed present, the technician must be able to rapidly remove power from the filter to minimize damaging components or operating the filter fuses.</p> <p>If the actual measured currents are within the acceptable levels for the rating of the filter, but there are short periods (&lt;60 seconds) that exceed the trip threshold, increasing the time to fault setup parameter (1A) may alleviate the problem.</p> <p>The factory default setting for the <i>Filter Over-current Delayed Trip</i> (parameter 6A) is 160% of the filter's nominal fundamental current rating as determined by the filter's kVar, frequency, and voltage ratings (parameters 3A, 4a &amp; 8A). It may be acceptable to increase the slow trip parameter setup 6A. However, it is recommended that you consult the technical support department at the factory if this becomes necessary.</p>

### Troubleshooting Units Equipped with Pilot Lights

Units rated 20 kVar and less, or over 120 kVar, have *Blown Fuse* and *Filter Enabled* pilot lights to indicate their operating status and are not equipped with the HG2 Protection Monitor as standard. Troubleshooting information for units equipped with the HG2 Protection Monitor is provided in the previous section under the heading *Troubleshooting Units Equipped with the HG2 Protection Monitor*.

#### *Filter Enabled Pilot Light*

The *Filter Enabled* pilot light indicates that the *Filter Enable* input is closed.

#### *Blown Fuse Indicating Pilot Lights*

If a *Blown Fuse Indicating* pilot light is illuminated, the corresponding fuse, Fu1(a), Fu2(a), or Fu3(a) has blown. These fuses protect the three-phase HG7 filter power circuitry. Check for damaged components or wiring in the filter power circuit. Check for discolored or burned components and deformed or leaking capacitors. Damaged components can be caused by overheating. Check to see that the ambient temperature is not excessive and make sure that the unit is receiving an adequate flow of cooling air. Check the fan if the unit has one.

# POWER MONITOR PACKAGE ONLY

## HG2 Protection Monitor Calibration

### Introduction

The HG2 has calibration adjustments, which can be used to calibrate the unit's filter current, line voltage, and line current *Operating Parameter* displays. The HG2 should not be re-calibrated unless re-calibration is indicated by the troubleshooting procedure or the installation of replacement parts makes re-calibration necessary. The *Calibration Mode* is the same as the normal running mode except that the HG2 does not trip in response to fault conditions.

### HG2 Protection Monitor Calibration Procedure

<p><b>Warning</b></p> 	<p>Only qualified electricians should carry out all electrical installation and maintenance work on the HG7 Harmonic filter.</p> <p><b>Personnel performing the calibration procedure must be capable of safely working on powered equipment.</b> To calibrate the HG2, it is necessary to operate the drive and HG7 filter while measuring actual operating currents and voltages inside the unit.</p> <p>When in calibrate mode, the filter will not automatically disconnect upon recognizing a fault condition. If a fault occurs during calibration, the technician must be able to rapidly remove power from the filter to minimize damaging components or blowing the filter fuses.</p>
---	--

### Required Equipment

- ◆ AC voltmeter and ammeter or multi-meter designed for true RMS measurements in a harmonic rich circuit and suitable for the rated current and voltage marked on the nameplate of the HG7 filter.
- ◆ Clamp-on current probe suitable for the rated current and voltage marked on the nameplate of the HG7 filter.
- ◆ Clip-on voltage probes suitable for the rated voltage marked on the nameplate of the HG7 filter. Select probes that can be securely clipped on to the test points without shorting between points or falling off.

### Measuring Voltages and Currents

To locate the line current, filter current, and line voltage measurement points, refer to the schematic diagram and outline and mounting dimension drawing for the specific unit that will be calibrated. Some typical drawings are included at the end of this manual.

<p><b>Warning</b></p> 	<p>The safest procedure is to attach and remove the voltage and current probes only when power is disconnected from the equipment. Capacitors in the HG7 harmonic filter are equipped with bleeder resistors to automatically discharge them to 50 volts or less within 1 minute after power is disconnected, but the equipment should be considered to be "live" for at least 5 minutes.</p>
---	---

### Calibration Potentiometer Locations

The calibration potentiometers are located behind the right edge of the HG2 board as viewed from the keypad side of the HG2. Refer to *Figure 5 – HG2 Keypad View*. When viewing the component side of the HG2 board, the calibration potentiometers are on the left edge of the board. Refer to *Figure 6 – HG2 Board Component View*.

## POWER MONITOR PACKAGE ONLY

<b>Warning</b> 	<b>Line voltage is connected to terminals J2, J3, and J4 at the top edge of the HG2 board.</b> The board circuitry is also connected to 120 volts.
---	---

### Calibration Procedure

Perform the *Setup Procedure* on page 34 and verify that all settings are correct for the application. Set parameter 11A to 1, *Calibration Mode*. When you exit the *Setup Mode*, the HG2 will be in the *Calibration Mode*. The unit may then be calibrated using the following procedure.

1. Press the UP key to select parameter "C", *Filter Current*.
2. The *Filter Current* calibrations can be performed without the drive operating to avoid the difficulty of making adjustments with rapidly changing currents.
3. Press the SELECT key to select "L 1." With an ammeter current probe on filter line, L1, adjust potentiometer R43 to match the ammeter reading.
4. Press the SELECT key to select "L 2." With an ammeter current probe on filter line, L2, adjust potentiometer R44 to match the ammeter reading.
5. Press the SELECT key to select "L 3." With an ammeter current probe on filter line, L3, adjust potentiometer R45 to match the ammeter reading.
6. Press the UP key to select parameter "U," *Line Voltage*.
7. Press the SELECT key to select "L 1." With a voltmeter connected between L1 and neutral, adjust potentiometer R68 to match the voltmeter reading. If the neutral is not accessible, then connect between L1 and L2 and calculate the line to neutral voltage.
8. Press the SELECT key to select "L 3." With a voltmeter connected between L3 and neutral, adjust potentiometer R94 to match the voltmeter reading. If the neutral is not accessible, then connect between L1 and L3 and calculate the line to neutral voltage.
9. Press the SELECT key to select "L 1." Recheck the "L 1" setting and readjust if necessary. Recheck the "L 3" setting, readjust if necessary since there is some interaction between R68 and R94. There is no adjustment for "L 2".
10. Press the UP key to select parameter "A," *Line Current*.
11. The drive should be running while performing the Line Current calibrations. For optimum accuracy, the actual current as measured with an ammeter, should be more than half the unit's rated current. Due to the low resolution of the A/D converters, the display readings are not intended to be used for certification purposes.
12. Press the SELECT key to select "L 1." With an ammeter current probe on source line, L1, adjust potentiometer R52 to match the ammeter reading.
13. Press the SELECT key to select "L 2." With an ammeter current probe on source line, L2, adjust potentiometer R53 to match the ammeter reading.
14. Press the SELECT key to select "L 3." With an ammeter current probe on source line, L3, adjust potentiometer R54 to match the ammeter reading.
15. Remove power to the unit to exit the Calibration Mode.
16. Restart the filter in the normal operating mode, and verify proper operation.

## POWER MONITOR PACKAGE ONLY

### Troubleshooting Calibration Problems

If, during the Calibration Procedure, a parameter is missing or non-responsive, check for proper analog voltage levels at the points indicated in *Figure 7 – HG2 Connection Details – Board Component View*. Care must be taken not to short circuit between the board test points. **Warning! Line voltage potentials are present on the board.**

If the analog voltage levels are normal and the board cannot be calibrated, the board is probably defective. Replace the board and perform the *Setup* and *Calibration* procedures.

# POWER MONITOR PACKAGE ONLY

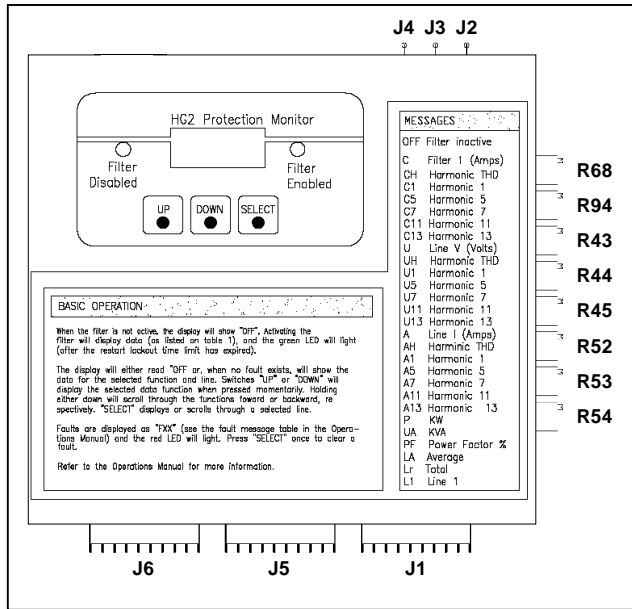

Figure 5 – HG2 Keypad View

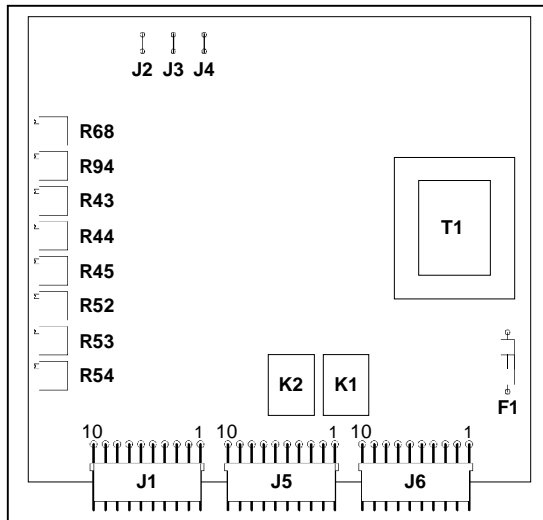
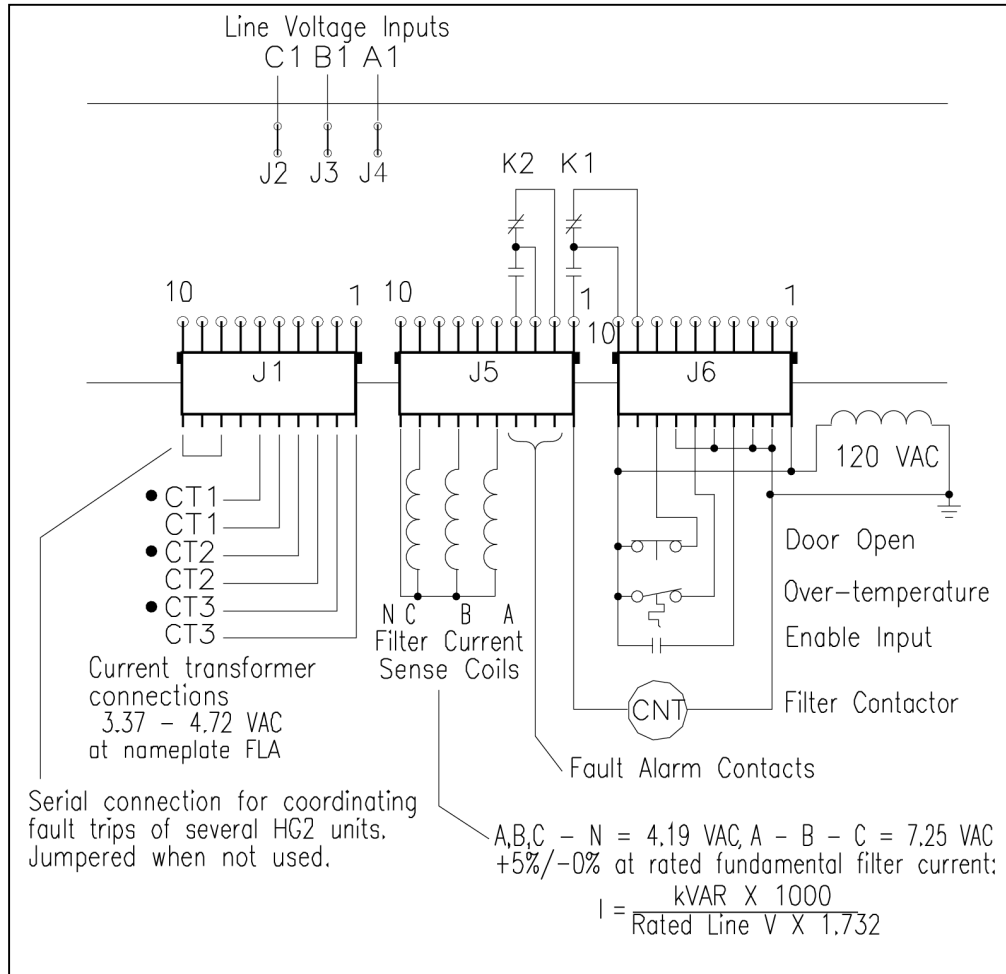

Figure 6 – HG2 Board Component View

# POWER MONITOR PACKAGE ONLY



**Figure 7 – HG2 Connection Details – Board Component View**

## Replacement Parts

If replacement parts are needed, please contact your TCI representative. To ensure that the HG7 harmonic filter continues to perform to its original specifications, replacement parts should conform to TCI specifications.

## Factory Contacts and Tech Support

For technical support, contact your local TCI distributor or sales representative.

You can contact TCI directly at 800-TCI-8282. Select "Customer Service" or "Tech Support" and have your HG7 harmonic filter nameplate information available.



## COMPONENT PACKAGE OPTION (CP)

### Component Package Option (CP)

#### “CP” Option Models

The HG7 “CP” Option is a harmonic filter component package designed and developed by TCI to allow qualified customers to build harmonic filters to reduce the harmonic currents drawn from the power source by variable speed drives. The HG7 “CP” Option is available for 200/208, 230/240, 460/480 volt, 575/600 volt systems (60 Hz) and 400 volt systems (50 Hz). When properly designed, assembled, and installed, the completed product is intended to be suitable for use with 3-phase diode bridge rectifier loads such as PWM AC drives. SCR or thyristor loads such as DC drives would require a different filter configuration outside the scope of this product offering. Please contact TCI Technical Support for additional information.

### Product Description

#### HG7 CP Option Harmonic Filter

The HG7 “CP” Option filter components is a package of the primary passive filter components needed to build a harmonic filter and installed on the input terminals of a variable speed drive or drive system. The filter component are tuned to provide a low impedance path for the major harmonic currents demanded by the drive when following the schematic connections used by TCI in the HG7 HarmonicGuard filter.

The HG7 “CP” Option filter component package consists of the following components.

- ◆ A KDR input series reactor.  
A TCI 3-phase tuning reactor specifically designed for the HG7 filter. High-endurance, harmonic-rated capacitors.
- ◆ Bleeder resistors to ensure safe capacitor discharge upon filter shutdown.
- ◆ Capacitor mounting brackets that allow for a neat and orderly mounting and connection of the cylindrical power capacitors.

## COMPONENT PACKAGE OPTION (CP)

### Product Technical Specifications

Table 9 lists the major technical specifications and intended environments for the HG7 Harmonic Filter components.

**Table 9 – HG7 “CP” Option Harmonic Filter Components Technical Specifications**

Voltage ratings	240, 480 and 600 V, 3 ph, 60 Hz 400 V, 3 ph, 50 Hz
kVar ratings	3 to 270 kVar depending on voltage. See Rating table.
Load types	3-phase diode bridge rectifier loads such as PWM AC drives
Load power range	7.5 -900 Hp depending on voltage.
Series Reactor Current ratings	The included series reactors can tolerate 200% of rated current for at least 3 minutes.
SCCR (short circuit current rating)	Standard rating is 10kA.
Maximum elevation for all components	3,000 feet (1,000 meters) as standard. Product must be equipped with special cooling provisions for operation above this altitude.
Maximum ambient operating temperature	50°C (122°F) – Open Panel; 40°C (104°F) – Enclosed Panel. Product must be equipped with special cooling provisions for operation above this temperature.
Maximum ambient storage temperature	60°C (140°F)
Maximum humidity, operating or storage	95%, non-condensing.
Agency approvals or certifications on components	All components are UL component recognized and can be used to develop a cUL Listed to UL508A and CSA-C2.2 No. 14 system when designed and built by a qualified UL certified facility.
Insertion Impedance of the series line reactor	+/- 10% at full load current
Capacitors	Oil filled high endurance design (no PCBs)

# COMPONENT PACKAGE OPTION (CP)

## Installation

Review all Pre-Installation and Installation instructions at the beginning of this manual.

If you are assembling a CP unit in your own enclosure, you must provide an enclosure that is adequately sized and ventilated sufficiently to prevent overheating. The maximum temperature of the air around the HG7 filter capacitors and Protection Monitor should not exceed 50°C (122°F).

### **KLR/KDR Line Reactor Installation Instruction**

Recommendations and Considerations:

When installing the KLR/KDR Line Reactors on the INPUT side of the Variable Frequency Drive (VFD), please use the following guidelines when wiring the unit:

The KLR/KDR Line Reactor is a 3-phase device and should be wired in series and positioned on the input side of the VFD.

All Terminal Block connectors will be marked. A1, B1, and C1 are the input terminals where the 3 phases of incoming power are to be wired. As a result, A2, B2, and C2 are the output terminals. Units with copper bus or ring lug terminals are not marked. In these cases, either the upper terminals or the lower terminals can be used as the input terminals, as long as the selection is consistent. For example, if an upper terminal is selected as the input, all upper terminals must be input terminals. Wiring from the output terminals should connect to the input of the VFD.

Refer to NEC wiring practices for appropriate wire sizes for your application.

**Power Wiring:** Only use 75°C copper conductors, unless the wire connector is marked for Al/Cu, then the use of aluminum wire is permitted.

TCI recommends that these reactors be wired and located as close to the front end of the VFD as possible to have the greatest success in both protecting the VFD as well as mitigating line harmonics. We recommend this be 10 feet of cable or less.

In standard 40°C ambient or less installations, a clearance of 3 inches on all sides of the reactors and its enclosure is recommended for assisting in heat dissipation and ample wire bending space. This is a general guideline for typical applications. If the reactor is being installed next to a heat sensitive instrument or control device, we recommend reviewing specific requirements or heat limitations. Line reactor heat loss information is available in the standard TCI product literature or on the web at [www.transcoil.com](http://www.transcoil.com).

These reactors are designed to be floor-mounted, or wall-mounted. Large open-style devices should be panel mounted by incorporating a bracket that would act as a shelf to support the reactor and/or enclosure. When installing an open style device in an existing control cabinet, drive cabinet, motor control center, or other large enclosure, the reactor should be mounted in the lower half of the cabinet to prevent hot spots or pockets of heat. Locating the reactor in the lower half of the cabinet typically allows better thermal dissipation and heat convection. Reactors with ducts should be mounted vertically for proper cooling.

## COMPONENT PACKAGE OPTION (CP)

### Field Wiring Information

Below is the typical wiring diagram for the 3-phase reactor applied to the front end of the Variable Frequency Drive (VFD). Single-phase applications are acceptable, however, it is important to size the unit based on the single phase Full Load Amperage of the VFD. The input and output connections should be on terminals A and C to ensure proper performance.

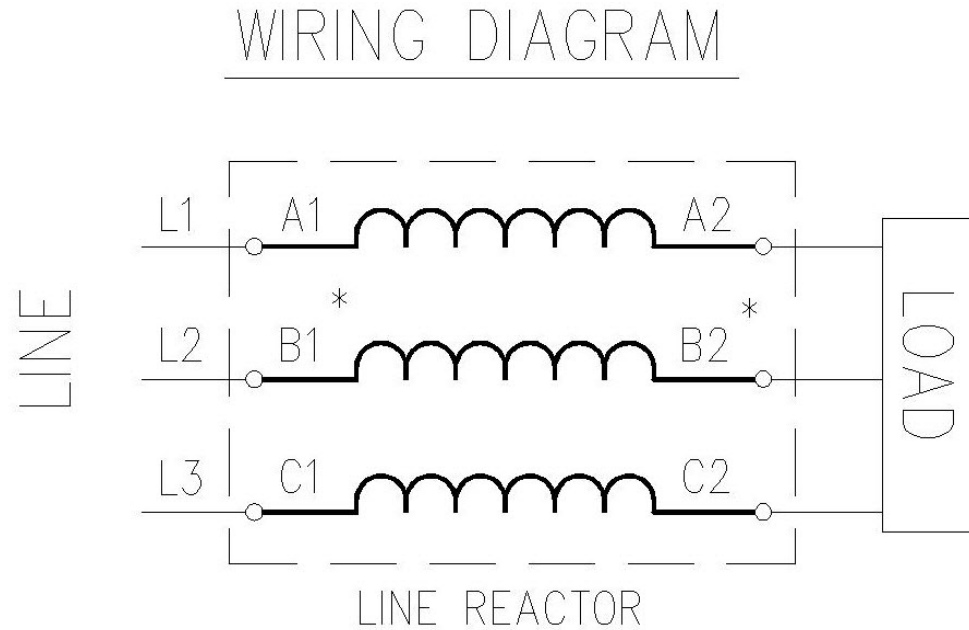

\* FOR SINGLE PHASE APPLICATIONS USE  
COILS A AND C.  
INSULATE TERMINALS B1 AND B2.





TCI, LLC  
7878 N. 86<sup>th</sup> Street  
Milwaukee, Wisconsin 53224

Phone: 414-357-4480  
Fax: 414-357-4484  
Helpline: 800-TCI-8282

Web Site: <http://www.transcoil.com>