

MotorGuard

KMG High Performance Output Sine Wave Filter

Installation, Operation and Maintenance Manual



MotorGuard™

**KMG High Performance Output Sinewave Filter
Installation, Operation and Maintenance Manual**



TCI, LLC
7878 N. 86th Street
Milwaukee, Wisconsin 53224

Phone: 414-357-4480
Fax: 414-357-4484
Helpline: 800-TCI-8282

Web Site: <http://www.transcoil.com>

© 2010

Table of Contents

Safety Instructions	5
Overview	5
Warnings and Cautions	5
General Safety Instructions	6
Introduction	7
Intended Audience	7
Additional Information.....	7
Installation Checklist.....	7
Receiving Inspection and Storage	8
Receiving Inspection	8
Warranty Information.....	8
Storage Instructions.....	8
Product Description	9
MotorGuard Sine Wave Filter.....	9
Nameplate Data.....	10
Model Number Encoding.....	11
Standard Product Ratings and Dimension Tables	12
Product Technical Specifications.....	17
Pre-installation Planning	19
Verify the Application.....	19
Select a Suitable Location	19
Power Wiring.....	20
Control Wiring (for units with boards)	20
Optional Features	20
Installation Guidelines	21
Mounting.....	21
Wiring.....	21
MotorGuard Operation	24
Adjustments	24

Start Up (Commissioning)	24
Operation	24
Maintenance and Service.....	25
MotorGuard Reliability and Service Life.....	25
Periodic Maintenance	25
For Units with Boards:.....	25
Troubleshooting	26
Replacement Parts	29
Factory Contacts and Tech Support.....	29
Drawings	30
Typical Isometric Drawings and Schematic Diagrams.....	30

Safety Instructions

Overview

This section provides the safety instructions which must be followed when installing, operating and servicing the KMG MotorGuard Filter. If neglected, physical injury or death may follow, or damage may occur to the MotorGuard or equipment connected to the MotorGuard. The material in this chapter must be read and understood before attempting any work on, or with, the product.

The MotorGuard is intended to be connected to the output terminals of a variable frequency drive (VFD). An AC motor is connected to the output terminals of the MotorGuard and receives power from the VFD through the MotorGuard. The instructions, and particularly the safety instructions, for the VFD, motor and any other related equipment must be read, understood and followed when working on any of the equipment.

Warnings and Cautions



This manual provides two types of safety instructions.

Warnings caution readers about conditions, which can, if proper steps are not taken, lead to a serious fault condition, physical injury, or death.

Cautions are used to draw attention to instructions. Failure to properly follow such instructions may lead to a malfunction and possible equipment damage.

Warnings

Readers are informed of situations that can result in serious physical injury and/or serious damage to equipment with warning statements marked with the following symbols:

Warning 	Dangerous Voltage Warning: warns of situations in which a high voltage can cause physical injury and/or equipment damage. The text next to this symbol describes ways to avoid the danger.
Warning 	General Warning: warns of situations that can cause physical injury and/or equipment damage by means other than electrical. The text next to this symbol describes ways to avoid the danger.
Warning 	Electrostatic Discharge Warning: warns of situations in which an electrostatic discharge may damage equipment. The text next to this symbol describes ways to avoid the danger.









Cautions

Readers are informed of situations that can lead to a malfunction and possible equipment damage with caution statements:

Caution	General Caution: identifies situations that can lead to a malfunction and possible equipment damage. The text describes ways to avoid the situation.
----------------	--

General Safety Instructions

These safety instructions are intended for all work on the MotorGuard. Additional safety instructions are provided at appropriate points on other sections of this manual.

<p>Warning</p> 	<p>Be sure to read, understand, and follow all safety instructions.</p>
<p>Warning</p> 	<p>Only qualified electricians should carry out all electrical installation and maintenance work on the MotorGuard.</p>
<p>Warning</p> 	<p>All wiring must be in accordance with the National Electrical Code (NEC) and/or any other codes that apply to the installation site.</p>
<p>Warning</p> 	<p>Disconnect all power before working on the equipment. Do not attempt any work on a powered MotorGuard.</p>
<p>Warning</p> 	<p>The MotorGuard, VFD, motor, and other connected equipment must be properly grounded.</p>
<p>Warning</p> 	<p>The MotorGuard receives power from two or more sources.</p> <p>Three-phase power from the output terminals of the VFD is connected to the main input terminals of the MotorGuard.</p> <p>Power from a single-phase 120, 240 or 480 volt supply is connected to the MotorGuard for the cooling fan and monitor board.</p> <p>The monitor board alarm contacts may be connected to a circuit that receives power from another source.</p> <p>All of these sources of power must be disconnected before working on the MotorGuard.</p>
<p>Warning</p> 	<p>After switching off the power, always allow 5 minutes for the capacitors in the MotorGuard and in the VFD to discharge before working on the MotorGuard, the VFD, the motor, or connecting wiring. It is good practice to check with a voltmeter to make sure that all sources of power have been disconnected and that all capacitors have discharged before beginning work.</p>
<p>Warning</p> 	<p>The VFD output terminals and the motor cables are at a dangerously high voltage when power is applied to the VFD regardless of motor operation.</p>

Introduction

Thank you for selecting the KMG MotorGuard High Performance Output Filter. TCI has produced this filter for use in many PWM variable frequency drive (VFD) applications that require low distortion sine wave output power. This manual describes how to install, operate, and maintain the MotorGuard filter.

Intended Audience

This manual is intended for use by all personnel responsible for the installation, operation, and maintenance of the MotorGuard. Such personnel are expected to have knowledge of electrical wiring practices, electronic components, and electrical schematic symbols.

Additional Information

Caution	This manual provides general information describing your MotorGuard filter. More specific information is provided by the drawings shipped with the unit. Be sure to carefully review the information provided by these drawings. Information provided by the drawings shipped with the unit takes precedence over the information provided in this manual.
----------------	--

Installation Checklist

The following are the key points to be followed for a successful installation. These points are explained in detail in the following sections of this manual.

- Make sure that the installation location will not be exposed to direct sunlight, corrosive or combustible airborne contaminants, excessive dirt, or liquids.
- Select a mounting area that will allow adequate cooling air and maintenance access.
- Make sure that all wiring conforms to the requirements of the National Electric Code (NEC) and/or other applicable electrical codes.
- Connect the MotorGuard equipment grounding lug to the system ground of the premises wiring system. Use a properly sized grounding conductor.
- Wire the output power terminals of the VFD, T1(U), T2(V), & T3(W) to the input terminals of the MotorGuard, U, V, & W.
- Wire the output power terminals, of the MotorGuard, T1, T2, & T3 to the motor.
- Connect control power to the MotorGuard.
- For monitor board option: Connect the MotorGuard fault relay contact to the appropriate fault monitoring circuit.
- Check the MotorGuard configuration settings to ensure proper voltage is selected.
- Make sure that the VFD is set for operating modes and ranges that are compatible with the MotorGuard.
- Check everything thoroughly before operating the equipment.

Receiving Inspection and Storage

Receiving Inspection

The MotorGuard has been thoroughly inspected and functionally tested at the factory and carefully packaged for shipment.

When you receive the unit, you should immediately inspect the shipping container and report any damage to the carrier that delivered the unit.

Verify that the part number of the unit you received is the same as the part number listed on your purchase order.

Warranty Information

TCI, LLC (“TCI”) warrants to the original purchaser only that MotorGuard products will be free from defects in materials and workmanship under normal use and service for a period originating on the date of shipment from TCI and expiring at the end of One (1) year of useful service, not to exceed 18 months from the date of shipment. The foregoing limited warranty is TCI’s sole warranty with respect to its products and TCI makes no other warranty, representation or promise as to the quality or performance of TCI’s products. **THIS EXPRESS LIMITED WARRANTY IS GIVEN IN LIEU OF AND EXCLUDES ANY AND ALL EXPRESS OR IMPLIED WARRANTIES INCLUDING, WITHOUT LIMITATION, ANY IMPLIED WARRANTY OF MERCHANTABILITY OR FITNESS FOR A PARTICULAR PURPOSE.**

This warranty shall not apply if the product was:

- a) altered or repaired by anyone other than TCI;
- b) applied or used for situations other than those originally specified; or
- c) subjected to negligence, accident, or damage by circumstances beyond TCI’s control, including but not limited to, improper storage, installation, operation or maintenance.

If, within the warranty period, any product shall be found in TCI’s reasonable judgment to be defective, TCI’s liability and the Buyer’s exclusive remedy under this warranty is expressly limited, at TCI’s option, to (i) repair or replacement of that product, or (ii) return of the product and refund of the purchase price.

Such remedy shall be Buyer’s sole and exclusive remedy. **TCI SHALL NOT, IN ANY EVENT, BE LIABLE FOR INCIDENTAL DAMAGES OR FOR CONSEQUENTIAL DAMAGES INCLUDING, BUT NOT LIMITED TO, LOSS OF INCOME, LOSS OF TIME, LOST SALES, INJURY TO PERSONAL PROPERTY, LIABILITY BUYER INCURS WITH RESPECT TO ANY OTHER PERSON, LOSS OF USE OF THE PRODUCT OR FOR ANY OTHER TYPE OR FORM OF CONSEQUENTIAL DAMAGE OR ECONOMIC LOSS.**

The foregoing warranties do not cover reimbursement for removal, transportation, reinstallation, or any other expenses that may be incurred in connection with the repair or replacement of the TCI product.

The employees and sales agents of TCI are not authorized to make additional warranties about TCI’s products. TCI’s employees and sales agents oral statements do not constitute warranties, shall not be relied upon by the Buyer and are not part of any contract for sale. All warranties of TCI embodied in this writing and no other warranties are given beyond those set forth herein.

TCI will not accept the return of any product without its prior written approval. Please consult TCI Customer Service for instructions on the Return Authorization Procedure.

Storage Instructions

If the MotorGuard is to be stored before use, be sure that it is stored in a location that conforms to published storage humidity and temperature specifications stated in this manual. Store the unit in its original packaging.

Product Description

MotorGuard Sine Wave Filter

The MotorGuard is a low-pass sine wave filter designed and developed by TCI to deliver conditioned power to motor loads driven by PWM drives at a variety of lead lengths. The MotorGuard is available for 460/480 volt and 575/600 volt systems.

The MotorGuard is a passive filter connected in series with the output terminals of the variable frequency drive. It is designed to remove the carrier frequency distortion from the output voltage waveform. The use of this low-pass, L-R-C device will result in a nearly pure sine wave voltage profile. This design will reduce the effects of the reflected wave phenomenon, (dv/dt), such as insulation damage or premature failure in motors, transformers and VFD output cables. The MotorGuard will also reduce the effects of stray high frequency harmonic currents, thereby reducing VFD ground fault problems and noise interference in transducer signals.

The MotorGuard is available in two package configurations: Industrial and GP. The Industrial filter is a stand-alone device that can be furnished in its own enclosure and mounted adjacent to the VFD, and is also available on an open panel for mounting within an enclosure provided with the VFD or other equipment. The GP filter is furnished in its own enclosure and mounted adjacent to the VFD.

The MotorGuard is suitable for all lead lengths extending as far as 15,000 feet.

The MotorGuard consists of the following standard features and components:

- ◆ An R-L-C power filter circuit with:
 - A TCI 3-phase reactor specifically designed for the MotorGuard
 - Power resistors
 - High-endurance, harmonic-rated capacitors
- ◆ Bleeder resistors to ensure safe capacitor discharge upon filter shutdown.
- ◆ Compression terminals for ease and integrity of all power wiring.
- ◆ Cooling fans to ensure adequate cooling and safe operating temperatures.

Optional Monitor Board is available:

- ◆ A filter performance monitor and alarm circuit with:
 - Monitor board with relay and status indicating lights
 - Control transformer for control voltage power
 - Compression terminal blocks for all control wiring

Nameplate Data

Figure 1 shows an example of a MotorGuard nameplate. The following information is marked on the nameplate:

- ◆ Part number: encoded model number explained on the following page
- ◆ FLA: the rated continuous operating current (RMS amps)
- ◆ System Voltage: the maximum VFD output voltage (fundamental)
- ◆ Hz: the maximum VFD output frequency (fundamental)
- ◆ Phase: 3 – The MotorGuard is designed for use only with 3 phase motors.
- ◆ Drawing #: outline and mounting dimension of filter
- ◆ Schematic #: schematic diagram of filter
- ◆ Manufacturing #: for TCI internal use
- ◆ Enclosure Type: Industrial filters are open panel construction or NEMA 1 enclosed. GP filters are NEMA 1 or NEMA 3R enclosed.

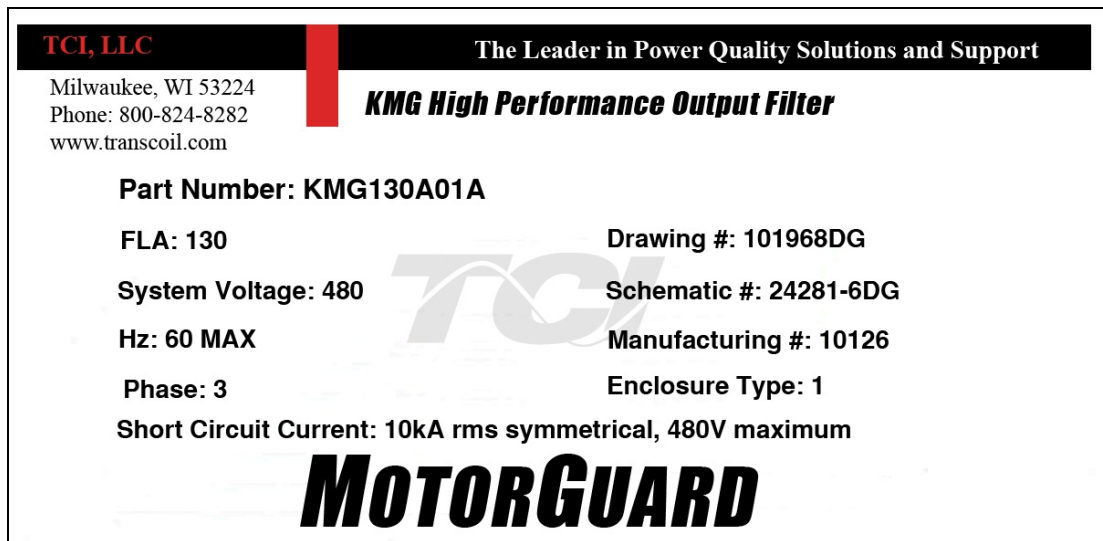

Figure 1 – Example of MotorGuard Nameplate

Model Number Encoding

Figures 2a and 2b identify the significance of each character in the MotorGuard model number. The example model number, KMG130A01A designates an Industrial MotorGuard that is rated 130 amps, 480 volts, and is furnished in a NEMA 1 enclosure.

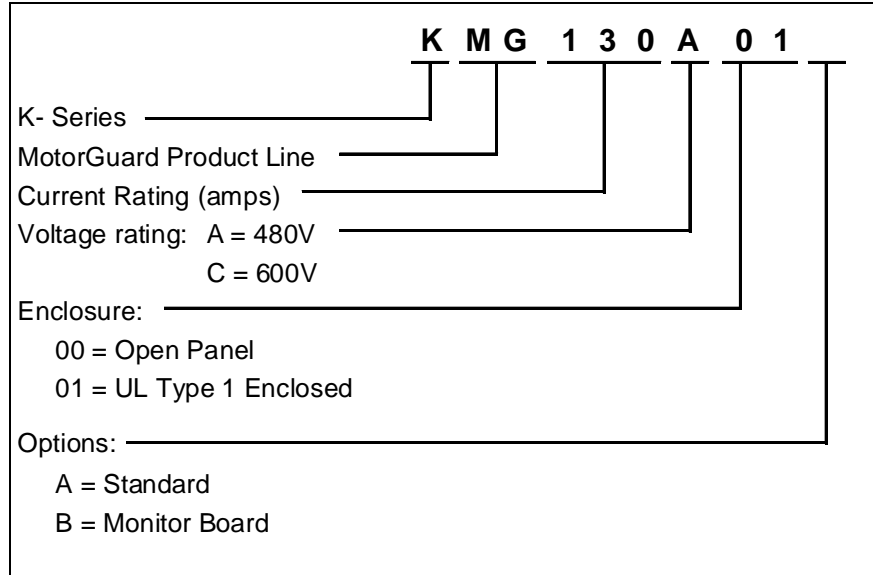

Figure 2a – MotorGuard Model Number Encoding – Industrial Version

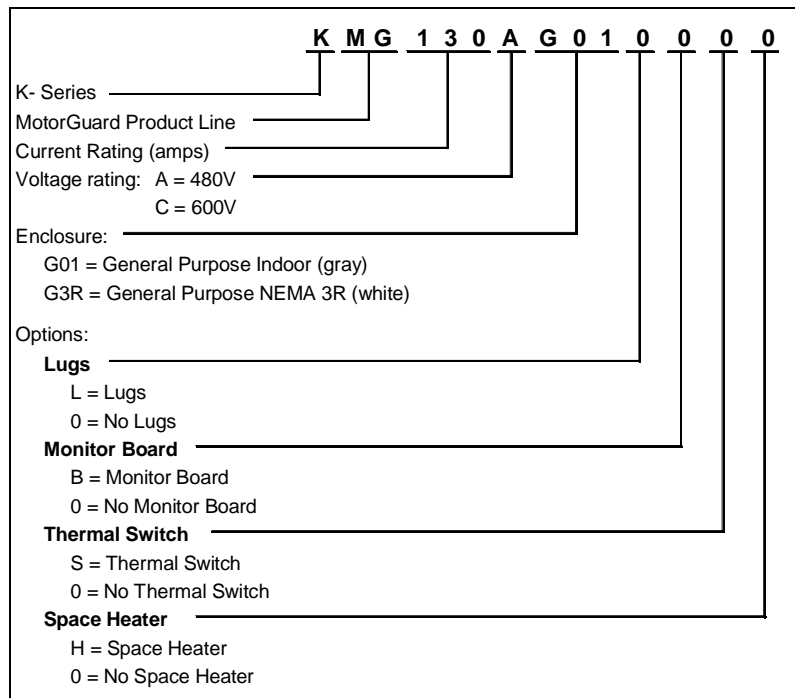

Figure 2b – MotorGuard Model Number Encoding – General Purpose Version

The MotorGuard has a current rating rather than a horsepower rating. The rating and dimension tables in the following section list the nominal horsepower ratings corresponding to the current ratings of the standard models.

Standard Product Ratings and Dimension Tables

The following tables list the ratings and dimensions of the standard MotorGuard models:

- ◆ Table 1 lists 480 Volt models on open panels.
- ◆ Table 2 lists 480 Volt models in NEMA 1 enclosures.
- ◆ Table 3 lists 600 Volt models on open panels.
- ◆ Table 4 lists 600 Volt models in NEMA 1 enclosures.
- ◆ Table 5 lists 480 Volt models in NEMA 1 enclosures.
- ◆ Table 6 lists 480 Volt models in NEMA 3R enclosures.
- ◆ Table 7 lists 600 Volt models in NEMA 1 enclosures.
- ◆ Table 8 lists 600 Volt models in NEMA 3R enclosures.

Table 1 – Industrial 480 Volt Models on Open Panels

Model Number	Nominal Horsepower	Current Rating (amps)	Heat Loss (Watts)	Weight (lbs.)	Height (in.)	Width (in.)	Depth (in.)
KMG8A00A	5	8	300	60	30.75	17.00	11.75
KMG12A00A	7.5	12	350	60			
KMG16A00A	10	16	400	70			
KMG23A00A	15	23	550	75			
KMG30A00A	20	30	650	85			
KMG35A00A	25	35	750	85			
KMG45A00A	30	45	850	100			
KMG55A00A	40	55	1000	115			
KMG65A00A	50	65	1100	160	56.00	17.00	11.75
KMG80A00A	60	80	1550	175			
KMG110A00A	75	110	1700	195			
KMG130A00A	100	130	2050	200			
KMG160A00A	125	160	2450	250			
KMG200A00A	150	200	3300	255			
KMG250A00A	200	250	3700	445			
KMG305A00A	250	305	4700	460			
KMG362A00A	300	362	4650	475	60.00	32.00	14.75
KMG420A00A	350	420	5400	580			
KMG480A00A	400	480	6050	635			
KMG600A00A	500	600	7350	645			
KMG750A00A	600	750	8800	760	60.00	32.00	17.75

Table 2 – Industrial 480 Volt Models in NEMA 1 Enclosures

Model Number	Nominal Horsepower	Current Rating (amps)	Weight (lbs.)	Height (in.)	Width (in.)	Depth (in.)
KMG8A01A	5	8	110	31.38 Wall Mounted	17.50	12.14
KMG12A01A	7.5	12	110			
KMG16A01A	10	16	120			
KMG23A01A	15	23	125			
KMG30A01A	20	30	140			
KMG35A01A	25	35	140			
KMG45A01A	30	45	155			
KMG55A01A	40	55	170			
KMG65A01A	50	65	245	56.00 Wall Mounted	17.52	16.40
KMG80A01A	60	80	260			
KMG110A01A	75	110	280			
KMG130A01A	100	130	300			
KMG160A01A	125	160	340			
KMG200A01A	150	200	345			
KMG250A01A	200	250	770			
KMG305A01A	250	305	790			
KMG362A01A	300	362	800	76.50 Free Standing	36.00	24.00
KMG420A01A	350	420	915			
KMG480A01A	400	480	970			
KMG600A01A	500	600	975			
KMG750A01A	600	750	1085			

Table 3 – Industrial 600 Volt Models on Open Panels

Model Number	Nominal Horsepower	Current Rating (Amps)	Heat Loss (Watts)	Weight (lbs.)	Height (in.)	Width (in.)	Depth (in.)
KMG8C00A	5	8	400	60	30.75	17.00	11.75
KMG10C00A	7.5	10	400	65			
KMG12C00A	10	12	400	70			
KMG20C00A	15	20	550	75			
KMG25C00A	20	25	700	85			
KMG28C00A	25	28	750	90			
KMG35C00A	30	35	800	100			
KMG45C00A	40	45	950	115	56.00	17.00	11.75
KMG55C00A	50	55	1200	160			
KMG65C00A	60	65	1600	175			
KMG80C00A	75	80	1650	195			
KMG110C00A	100	110	2250	225			
KMG130C00A	125	130	2300	250	56.00	17.00	14.78
KMG160C00A	150	160	2500	260	60.00	32.00	14.75
KMG200C00A	200	200	3500	450			
KMG250C00A	250	250	4500	460			
KMG305C00A	300	305	5100	475			
KMG362C00A	350	362	6100	580			
KMG420C00A	400	420	6900	635			
KMG500C00A	500	500	7900	645	60.00	32.00	16.00
KMG600C00A	600	600	9000	750			

Table 4 – Industrial 600 Volt Models in NEMA 1 Enclosures

Model Number	Nominal Horsepower	Current Rating (Amps)	Weight (lbs.)	Height (in.)	Width (in.)	Depth (in.)
KMG8C01A	5	8	115	31.38 Wall Mounted	17.50	12.14
KMG10C01A	7.5	10	115			
KMG12C01A	10	12	120			
KMG20C01A	15	20	135			
KMG25C01A	20	25	140			
KMG28C01A	25	28	145			
KMG35C01A	30	35	155			
KMG45C01A	40	45	175			
KMG55C01A	50	55	260			
KMG65C01A	60	65	265			
KMG80C01A	75	80	265			
KMG110C01A	100	110	290			
KMG130C01A	125	130	295	76.50 Free Standing	36.00	24.00
KMG160C01A	150	160	340			
KMG200C01A	200	200	770			
KMG250C01A	250	250	775			
KMG305C01A	300	305	790			
KMG362C01A	350	362	975			
KMG420C01A	400	420	975			
KMG500C01A	500	500	1015	60.00	32.00	16.00
KMG600C01A	600	600	1015			

Table 5 – General Purpose 480 Volt Models in NEMA 1 Enclosures

Model Number	Nominal Horsepower	Current Rating (Amps)	Weight (lbs.)	Height (in.)	Width (in.)	Depth (in.)
KMG55AG010000	40	55	209	36.50	18.67	29.50
KMG65AG010000	50	65	215			
KMG80AG010000	60	80	235			
KMG110AG010000	75	110	220			
KMG130AG010000	100	130	225			
KMG160AG010000	125	160	250			
KMG200AG010000	150	200	260	64.00	24.17	42.00
KMG250AG010000	200	250	595			
KMG305AG010000	250	305	625			
KMG362AG010000	300	362	630			
KMG420AG010000	350	420	635			
KMG480AG010000	400	480	635			
KMG600AG010000	500	600	755			

Table 6 – General Purpose 480 Volt Models in NEMA 3R Enclosures

Model Number	Nominal Horsepower	Current Rating (Amps)	Weight (lbs.)	Height (in.)	Width (in.)	Depth (in.)
KMG55AG3R0000	40	55	209	36.50	18.67	29.50
KMG65AG3R0000	50	65	215			
KMG80AG3R0000	60	80	235			
KMG110AG3R0000	75	110	220			
KMG130AG3R0000	100	130	225			
KMG160AG3R0000	125	160	250			
KMG200AG3R0000	150	200	260	64.00	24.17	42.00
KMG250AG3R0000	200	250	595			
KMG305AG3R0000	250	305	625			
KMG362AG3R0000	300	362	630			
KMG420AG3R0000	350	420	635			
KMG480AG3R0000	400	480	635			
KMG600AG3R0000	500	600	755			

Table 7 – General Purpose 600 Volt Models in NEMA 1 Enclosures

Model Number	Nominal Horsepower	Current Rating (Amps)	Weight (lbs.)	Height (in.)	Width (in.)	Depth (in.)
KMG45CG010000	40	45	209	36.50	18.67	29.50
KMG55CG010000	50	55	235			
KMG65CG010000	60	65	235			
KMG80CG010000	75	80	266			
KMG110CG010000	100	110	275			
KMG130CG010000	125	130	280			
KMG160CG010000	150	160	290	64.00	24.17	42.00
KMG200CG010000	200	200	570			
KMG250CG010000	250	250	615			
KMG305CG010000	300	305	620			
KMG362CG010000	350	362	650			
KMG420CG010000	400	420	675			
KMG500CG010000	500	500	810			
KMG600CG010000	600	600				

Table 8 – General Purpose 600 Volt Models in NEMA 3R Enclosures

Model Number	Nominal Horsepower	Current Rating (Amps)	Weight (lbs.)	Height (in.)	Width (in.)	Depth (in.)
KMG45CG3R0000	40	45	209	36.50	18.67	29.50
KMG55CG3R0000	50	55	235			
KMG65CG3R0000	60	65	235			
KMG80CG3R0000	75	80	266			
KMG110CG3R0000	100	110	275			
KMG130CG3R0000	125	130	280			
KMG160CG3R0000	150	160	290	64.00	24.17	42.00
KMG200CG3R0000	200	200	570			
KMG250CG3R0000	250	250	615			
KMG305CG3R0000	300	305	620			
KMG362CG3R0000	350	362	650			
KMG420CG3R0000	400	420	675			
KMG500CG3R0000	500	500	810			
KMG600CG3R0000	600	600				

Product Technical Specifications

Tables 9a, 9b, 10a, and 10b list the major technical specifications for the MotorGuard product line.

Table 9a – MotorGuard Technical Specifications – Industrial

Current ratings	Continuous current: 8 to 750 amps. See Rating and Dimension tables Intermittent current: 150% for 1 minute out of every 60 minutes
VFD Drive output voltage	460/480 and 575/600 V, 3 ph, at fundamental base frequency
VFD Drive output frequency	0 to 80 Hz
VFD Drive carrier frequency	2 kHz and 12 kHz, ideally 4 kHz to 8 kHz
Control power input	For fan operation.
Filter performance	Maximum peak voltage of output waveform – 480 V models: 1000 V – 600 V models: 1500 V Maximum dv/dt of output waveform – 480 V models: 500 V/μs – 600 V models: 1500 V/μs
Maximum elevation	3,000 feet (1,000 meters) as standard. Product must be equipped with special cooling provisions for operation above this level
Maximum ambient operating temperature	40 °C (104 °F) as standard. Product must be equipped with special cooling provisions for operation above this temperature.
Maximum ambient storage temperature	50 °C (122 °F)
Maximum humidity, operating or storage	95%, non-condensing.
Enclosure options	Open panel for mounting in an enclosure furnished by others NEMA 1 enclosure
Enclosure finish	Free standing enclosures: ANSI 61 gray Wall mount enclosures: White Matte (beige) Munsel 5.8Y7.83/1
Agency approvals or certifications	 UL and cUL Listed to UL508A and CSA-C22.2 No. 14
Insertion impedance	Approximately 6.5% at 60 Hz & full load current
Fusing and protection:	Unit has internal fuse protection and a performance monitoring circuit.
Capacitors	Oil filled high endurance design (no PCBs)

Table 9b – Only with Board Option

Status indication LEDs	Green LED indicates: "Control Power ON" Yellow LED indicates: "Normal Operation" (not faulted)
Fault relay	De-energized when a fault is detected. Form C contact for customer use. Rated 0.6 A at 125 VAC and 110 VDC, 2 A at 30 VDC.

Table 10a – MotorGuard Technical Specifications – General Purpose

Current ratings	Continuous current: 55 to 600 amps. See Rating and Dimension tables Intermittent current: 150% for 1 minute out of every 60 minutes
VFD Drive output voltage	460/480 and 575/600 V, 3 ph, at fundamental base frequency
VFD Drive output frequency	0 to 80 Hz
VFD Drive carrier frequency	2 kHz and 12 kHz, Ideally 4 kHz to 8 kHz
Control power input	For fan operation.
Filter performance	Maximum peak voltage of output waveform – 480 V models: 1000 V – 600 V models: 1500 V Maximum dv/dt of output waveform – 480 V models: 500 V/ μ s – 600 V models: 1500 V/ μ s
Maximum elevation	3,000 feet (1,000 meters) as standard. Product must be equipped with special cooling provisions for operation above this level
Maximum ambient operating temperature	40 °C (104 °F) as standard. Product must be equipped with special cooling provisions for operation above this temperature.
Maximum ambient storage temperature	50 °C (122 °F)
Maximum humidity, operating or storage	95%, non-condensing.
Enclosure options	General Purpose 3R enclosure
Insertion impedance	Approximately 6.5% at 60 Hz & full load current
Capacitors	Oil filled high endurance design (no PCBs)

Table 10b – Only with Board Option

Status indication LEDs	Green LED indicates: "Control Power ON" Yellow LED indicates: "Normal Operation" (not faulted)
Fault relay	De-energized when a fault is detected. Form C contact for customer use. Rated 0.6 A at 125 VAC and 110 VDC, 2 A at 30 VDC.

Pre-installation Planning

Verify the Application

MotorGuard Ratings

Make sure that the MotorGuard is correct for the application. The voltage and current ratings of the MotorGuard must match the output voltage and current ratings of the connected variable frequency drive as it is configured for use with the connected motor.

Variable Frequency Drive Settings

Make sure that the variable frequency drive will be set for operation modes and ranges that are compatible with the MotorGuard:

- ◆ Maximum output frequency: 80 Hz
- ◆ PWM switching frequency between 2 kHz and 12 kHz, ideally 4 kHz to 8 kHz
- ◆ Mode of operation: "scalar" or "V/Hz" without DC braking unless the drive application has been confirmed by TCI Technical Support

Select a Suitable Location

Environment

Locating the MotorGuard in a suitable environment will help ensure proper performance and a normal operating life.

Warning



Unless specifically labeled as approved for such use, this equipment is not suitable for use in an explosive atmosphere or in a "Hazardous (Classified) Location" as defined in article 500 of the National Electrical Code.

The unit must be installed in an area where it will not be exposed to:

- ◆ Corrosive liquids or gasses
- ◆ Explosive or combustible gases or dust
- ◆ Excessive airborne dirt and dust
- ◆ Excessive vibration

In addition to the above, products that are not in a 3R enclosure should not be exposed to:

- ◆ Direct sunlight
- ◆ Rain or excessive dripping liquids

Mounting Area

Select a mounting area that will allow sufficient cooling air to flow through the unit. Adequate space should be provided to allow access for maintenance.

Mounting an open panel unit

If you are mounting an open panel unit in your own enclosure, you must provide an enclosure that is adequately sized and ventilated sufficiently to prevent overheating. The rating and dimension tables for open panel units list the watts of heat loss that is dissipated by the MotorGuard. The maximum temperature of the air around the MotorGuard's capacitors and monitor board should not exceed 50 °C (104 °F).

Power Wiring

The conduit and wiring from the output of the variable frequency drive to the motor must be routed to the MotorGuard and then to the motor. When selecting a mounting location for the MotorGuard, plan for the routing of the power wiring.

Control Wiring (for units with boards)

Control Power

The MotorGuard requires 120 VAC single-phase power for the monitor board and cooling fan. The control power source must be ensured to be energized whenever the variable frequency drive is operating. A control power transformer is provided in the MotorGuard to allow control power to be obtained from the three-phase source that provides input power to the VFD. Fuses are provided on the control transformer, but the wires connecting control power to the MotorGuard will need to be appropriately protected at the power source.

Control Power VA Requirement

Refer to the drawings furnished with your MotorGuard to determine the control power VA required.

Fault Alarm Contact

The fault alarm relay is energized when control power is applied to the MotorGuard and the output waveform dv/dt and peak voltage are within specified limits. If the dv/dt or peak voltage limits are exceeded, the fault relay is de-energized. A set of form C contacts are provided for customer use.

Determine how the MotorGuard's performance alarm contact will be used. It may be connected to the VFD external fault input or to some supervisory control or alarm annunciation equipment. A MotorGuard fault alarm indicates that the MotorGuard is not providing adequate dv/dt and peak voltage protection. If the drive operation continues during a fault condition, the motor or other equipment may be damaged. To guard against damage, consider connecting the MotorGuard to automatically shut down the drive if a fault occurs. The best alternative to shutting down the drive is to provide an alarm to personnel who will promptly investigate the problem.

Optional Features

Additional wiring requirements may apply to MotorGuard units that are equipped with certain optional features such as a space heater or 120 VAC control power supplied directly rather than through a control power transformer. For instructions covering these additional requirements, refer to drawings and/or other supplemental information furnished with the unit.

Installation Guidelines

Mounting

The MotorGuard must be mounted vertically on a smooth, solid surface, free from heat, dampness, and condensation.

Wiring

Cable Entry Locations

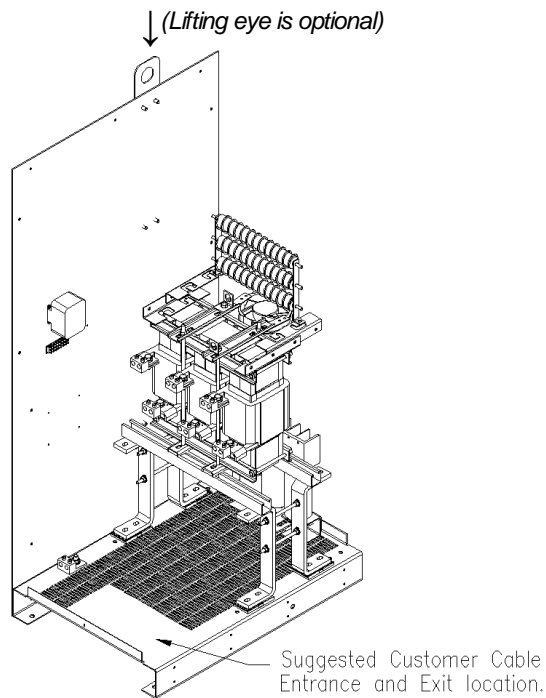

Figure 3 – Cable Entry Location for General Purpose units

Field Wiring Connection Terminals

Compression type terminals may be provided for all field wiring connections. The control circuit terminals will accommodate 18 AWG to 10 AWG wire and should be tightened to 18 in.-lbs. torque. The wire size capacity ranges and tightening torque for the grounding and power terminals are listed in Tables 11a and 11b.

Table 11 – Motor Power Terminal Wire Size Capacity Range and Tightening Torque (Cu or Al) - Industrial

KMG IND Model Numbers	Ground Lug		Input and Output Motor Power	
	Wire Size	Torque (in.-lb.)	Wire Size	Torque (in.-lb.)
KMG8A to KMG55A KMG8C to KMG45C	14 - 1/0 AWG	200	22 - 16 AWG 14 - 6 AWG 4 - 2 AWG and 1 AWG (7 & 19 strand only)	25 30 35
KMG65A to KMG130A KMG55C to KMG130C	6 - 2/0 AWG	120	6 - 2/0 AWG	120
KMG160A to KMG200A KMG160C to KMG200C	6 AWG - 250 MCM	275	6 AWG - 250 MCM	275
KMG250A to KMG305A KMG250C to KMG305C	4 AWG - 600 MCM or (2) 1/0 AWG - 250 MCM	500	4 AWG - 600 MCM or (2) 1/0 AWG - 250 MCM	500
KMG362A KMG362C to KMG420C	(2) 4 AWG - 350 MCM	275	(2) 4 AWG - 350 MCM	275
KMG420A to KMG600A KMG500C to KMG600C	(2) 2 AWG - 600 MCM	500	(2) 2 AWG - 600 MCM	500
KMG750A	(3) 2 AWG - 600 MCM	375	(3) 2 AWG - 600 MCM	375

Table 11b – Motor Power Terminal Wire Size Capacity Range and Tightening Torque (Cu or Al) – General Purpose

KMG GP Model Numbers	Ground Lug		Input and Output Motor Power	
	Wire Size	Torque (in.-lb.)	Wire Size	Torque (in.-lb.)
KMG55A KMG45C	14 - 1/0 AWG	200	22 - 16 AWG 14 - 6 AWG 4 - 2 AWG and 1 AWG (7 & 19 strand only)	25 30 35
KMG65A to KMG130A KMG55C to KMG130C	6 - 2/0 AWG	120	6 - 2/0 AWG	120
KMG160A to KMG200A KMG160C to KMG200C	6 AWG - 250 MCM	275	6 AWG - 250 MCM	275
KMG250A to KMG305A KMG250C to KMG305C	4 AWG - 600 MCM or (2) 1/0 AWG - 250 MCM	500	4 AWG - 600 MCM or (2) 1/0 AWG - 250 MCM	500
KMG362A KMG362C to KMG420C	(2) 4 AWG - 350 MCM	275	(2) 4 AWG - 350 MCM	275
KMG420A to KMG600A KMG500C to KMG600C	(2) 2 AWG - 600 MCM	500	(2) 2 AWG - 600 MCM	500

Connection Diagram

Figure 4 shows the typical wiring connections between the MotorGuard and the VFD and motor. Note that separate conduits may be required for the control power and fault contact wiring. Refer to the instructions for the VFD or other equipment to which the fault contact is connected.

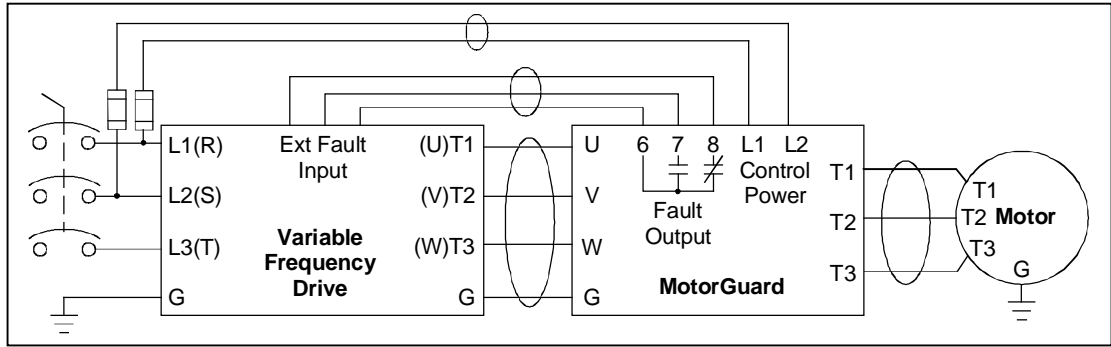

Figure 4 – Typical Connection Diagram

Grounding

The MotorGuard panel equipment grounding lug must be connected to the ground of the premises wiring system. The equipment grounding connection must conform to the requirements of the National Electric Code (NEC) and/or any other codes that apply to the installation site. The ground connection must be made using a wire conductor. Metallic conduit is not a suitable grounding conductor. The integrity of all ground connections should be periodically checked.

Power Wiring

Connect the output of the VFD, terminals T1(U), T2(V), & T3(W), to the input of the MotorGuard, terminals U, V, & W. Connect the motor to the output of the MotorGuard, terminals T1, T2, & T3.

Caution

Use wire that is appropriate for the voltage and current rating of the motor.
 For units rated less than 100 amps, use copper or aluminum wire with an insulation temperature rating of 60 °C or higher.
 For units rated 100 amps or more, use copper or aluminum wire with an insulation temperature rating of 75 °C or higher.
 The wire size and the voltage ratings must conform to the requirements of the National Electrical Code and/or other applicable electrical codes.
 Be sure to also follow the motor wiring instructions provided in the instruction manual for the VFD.

Control Wiring (for units with boards)

Connect control power to the MotorGuard. Be sure to provide fuses or other appropriate protection for the control power wiring. Make sure that the voltage and VA capacity of the control power source matches the MotorGuard's control power input ratings. Refer to the drawings shipped with the unit.

Connect the MotorGuard fault output relay contacts to the appropriate fault monitoring circuit. It may be connected to the VFD or to some supervisory control or alarm annunciation equipment.

MotorGuard Operation

Adjustments

Monitor Board Settings (for units with boards)

The monitor board configuration switches are factory set and should not be changed. The monitor board component layout is shown in Figure 5 in the *Maintenance and Service* section on a following page. Make sure that the configuration switches are set as follows:

- ◆ For 480 volt models: Set all sections of S1 to ON.
Alarm level $dv/dt = 1000 \text{ V}/\mu\text{s}$.
Alarm level peak voltage = 1000 V
- ◆ For 600 volt models: Set all sections of S1 to OFF.
Alarm level $dv/dt = 1500 \text{ V}/\mu\text{s}$.
Alarm level peak voltage = 1500 V

Variable Frequency Drive Settings

Make sure that the variable frequency drive is set for operation modes and ranges that are compatible with the MotorGuard:

- ◆ Maximum output frequency: 80 Hz
- ◆ PWM switching frequency between 2 kHz and 12 kHz, ideally 4 kHz to 8 kHz. Since the MotorGuard removes most of the harmonic content from the output waveform, quiet motor operation should be achieved with a switching frequency setting within this range.
- ◆ Mode of operation: "scalar" or "V/Hz" without DC braking unless the drive applications has been confirmed by TCI Technical Support

Start Up (Commissioning)

Caution	Thoroughly check the installation before applying power and operating the equipment for the first time.
Caution	Never Operate the MotorGuard without a load connected to its output terminals.

Before Applying Power for the First Time

Inspect the installation to make sure that all equipment has been completely and correctly installed in accordance with the *Installation Guidelines* section of this manual.

Before Operating the VFD for the First Time

- ◆ Make sure that the MotorGuard monitor board configuration switches are properly set as described above.
- ◆ Make sure that the variable frequency drive is set for operation modes and ranges that are compatible with the MotorGuard as described above.

Operation

Since the MotorGuard is a passive filter, it is always operating whenever the variable frequency drive is operating. Whenever the VFD is operating, control power should be applied to the MotorGuard so that the MotorGuard's cooling fan will operate and prevent it from overheating. Control power is also required for the performance monitoring and fault warning circuit.

Maintenance and Service

MotorGuard Reliability and Service Life

The MotorGuard has been designed to provide a service life that equals or exceeds the life of the variable frequency drive. It has been thoroughly tested at the factory to ensure that it will perform reliably from the moment it is put into service. The following periodic maintenance is recommended to ensure that the MotorGuard will always perform reliably and provide the expected service life.

Periodic Maintenance

Warning 	Only qualified electricians should carry out all electrical installation and maintenance work on the MotorGuard. Disconnect all sources of power to the VFD and MotorGuard before working on the equipment. Do not attempt any work on a powered MotorGuard.
---	--

Check to see that the installation environment remains free from exposure to excessive dirt and contaminants. Refer to the *Pre-installation Planning* section of this manual.

Check to make sure that the enclosure ventilation openings are clean and unobstructed.

Clean the air filter in units that have filtered air inlets. Clean as often as necessary to prevent dirt build-up from impeding air flow.

Inspect the interior of the enclosure for signs of overheated components. Clean the interior of the enclosure whenever excess dirt has accumulated.

Check the integrity of all power, ground, and control wiring connections.

For Units with Boards:

Check the status indicating lights on the monitor board.

Check the operation of the cooling fan.

Troubleshooting

<p>Warning</p> 	<p>Only qualified electricians should carry out all electrical installation and maintenance work on the MotorGuard.</p> <p>Disconnect all sources of power to the VFD and MotorGuard before working on the equipment. Do not attempt any work on a powered MotorGuard.</p>
---	--

Monitor Board (for units with boards)

Figure 5 shows the component layout of the monitor board. The monitor board contains the fault alarm relay and the status lights which are described below.

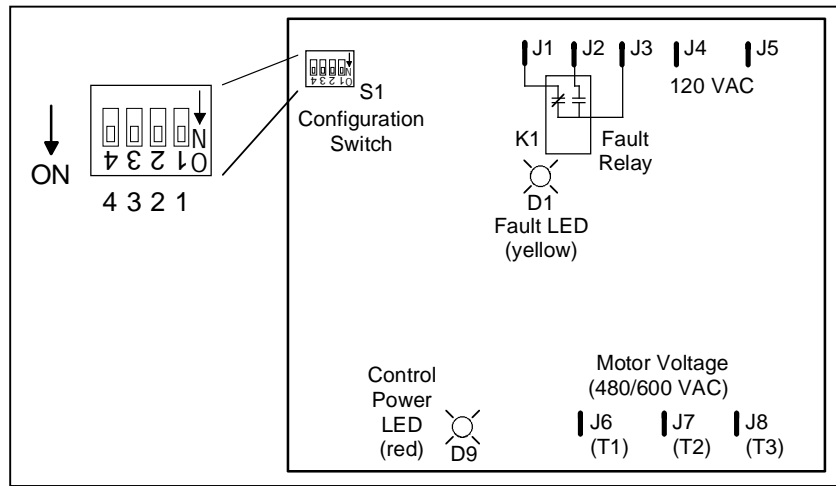

Figure 5 – Monitor Board Component Layout

Fault Alarm Relay

The fault alarm relay is energized when control power is applied to the MotorGuard and the output waveform dv/dt and peak voltage are within specified limits. If the dv/dt or peak voltage limits are exceeded, the fault relay is de-energized. A set of form C contacts are provided for customer use.

The fault relay contact may be connected to the VFD external fault input or other supervisory control or alarm annunciation equipment. A MotorGuard fault alarm indicates that the MotorGuard is not providing adequate dv/dt and peak voltage protection. If the drive operation continues during a fault condition, the motor or other equipment may be damaged.

Status Lights (for units with LEDs)

During normal operation, both the green LED and the yellow LED are illuminated. The green LED indicates that control power is applied to the monitor board. The yellow LED indicates that the fault relay is energized.

If the green LED is not illuminated, possible causes include:

- ◆ The source of control power is shut off.
- ◆ A fuse or other protective device external to the MotorGuard has interrupted control power. There may be a short circuit, ground fault, or overload condition in the MotorGuard or in some other wiring or equipment connected to the same source of control power.
- ◆ A primary or secondary control power transformer fuse has blown in the MotorGuard. There is probably a short circuit, ground fault, or overload condition in the MotorGuard. Check for evidence of damaged, burned, or overheated wiring or components.
- ◆ Check the following items:
 - Control circuit wiring
 - Control circuit transformer
 - Cooling fan
 - Monitor board

If the yellow LED is not illuminated, the monitor board has detected one or more of the following MotorGuard output fault conditions:

- ◆ The output waveform dv/dt exceeds the rated maximum (500 V/ μ s for 480 V units and 1500 V/ μ s for 600 V units).
- ◆ The output waveform peak voltage exceeds the selected maximum (1000 V for 480 V units and 1500 V for 600 V units).

The following conditions can cause MotorGuard output faults:

- ◆ Blown R-C power circuit fuses
If fuses are blown, check for damaged components or wiring in the R-C power circuit. Check for discolored or burned components and deformed or leaking capacitors. Damaged components can be caused by overheating – check fan. Components can also be damaged if the VFD has been operating improperly or out of range for proper MotorGuard performance.
- ◆ Damaged R-L-C power circuit components
Components can be damaged without blowing fuses. See above.
- ◆ VFD operating improperly or out of range for proper MotorGuard performance
- ◆ Problem with VFD or motor
- ◆ Loose power circuit wiring connections

Fuses

Table 12 lists the specifications for the RC power circuit fuses in the MotorGuard.

Table 12 – RC Power Circuit Fuses for Industrial Model

480 V Models			600 V Models		
MotorGuard Rating (Amps)	Power Circuit Fuse Rating		MotorGuard Rating (Amps)	Power Circuit Fuse Rating	
	Amps	Type		Amps	Type
8	2	Class CC Bussmann type KLD-R or equivalent	8	2	Class CC Bussmann type KLD-R or equivalent
12	2.5		10	2	
16	4		12	2.5	
23	6		20	5	
30	8		25	6	
35	9		28	7	
45	12		35	9	
55	15		45	12	
65	20		55	15	
80	20		65	20	
110	30		80	25	
130	35	110	30		
160	40	130	35		
200	50	160	40		
250	70	200	50		
305	80	250	70		
362	90	305	80		
420	110	362	90		
480	125	420	110		
600	150	500	125		
750	200	600	150		

Control Circuit Fuses

Refer to the drawings furnished with your MotorGuard for control circuit fuse specifications.

Evaluating MotorGuard Performance

The MotorGuard performance can be evaluated by checking the output voltage waveform with an oscilloscope.

<p>Warning</p> 	<p>Only qualified electricians should carry out all electrical installation and maintenance work on the MotorGuard.</p> <p>Exercise caution when checking waveforms with an oscilloscope.</p> <p>Use a dual probe, differential input set-up, or other means of isolating the scope chassis from the motor voltage.</p> <p>Disconnect power when attaching and removing the probes.</p>
---	---

Typical VFD Waveforms without Filtering

Figure 6 shows two examples of output voltage waveforms for a typical PWM variable frequency drive. The example labeled "VFD Output Voltage Waveform" is a "clean" waveform as it would appear with nothing connected to the VFD output terminals. The voltage peaks of this waveform are about 650 volts for a 480 volt drive. The example labeled "Motor Voltage Waveform" shows the

typical waveform at the terminals of a motor located a distance away from the VFD. This waveform has voltage peaks of 1500 volts or higher due to the voltage spikes caused by the reflected wave phenomenon.

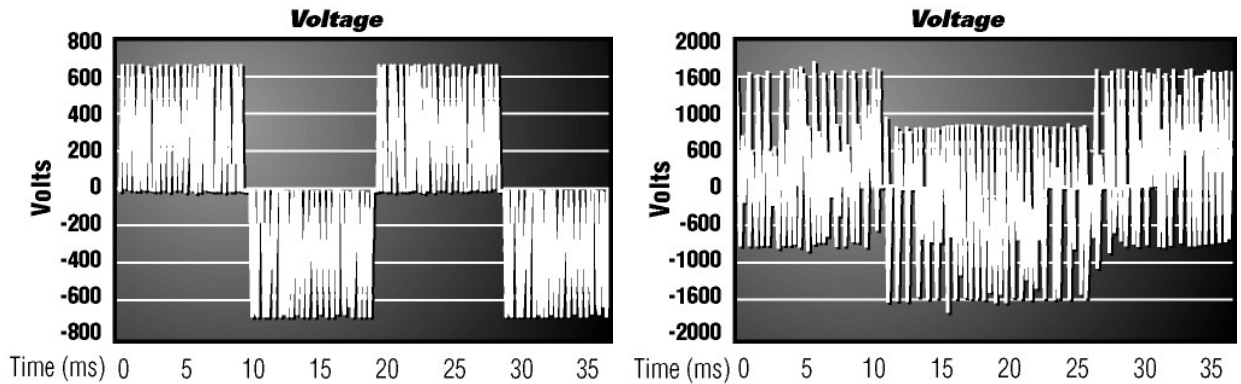

Figure 6 VFD Output Voltage Waveform

Motor Voltage Waveform With Reflected Voltage Spikes

Filter Output Performance

Figure 7 shows the voltage waveform at the output of the MotorGuard or at the terminals of a motor connected to the MotorGuard.

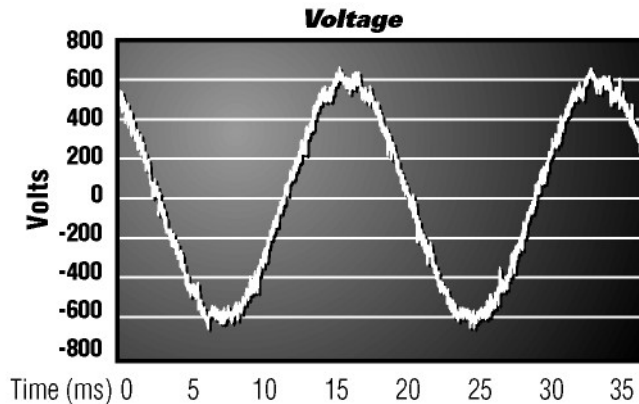

Figure 7 Motor Voltage Waveform Filtered by the MotorGuard

Replacement Parts

If replacement parts are needed, please contact your TCI representative. To ensure that the MotorGuard continues to perform to its original specifications, replacement parts should conform to TCI specifications.

Factory Contacts and Tech Support

For technical support, contact your local TCI distributor or sales representative.

You can contact TCI directly at 800-824-8282. Select "Customer Service" or "Technical Support" and have your MotorGuard nameplate information available.

Drawings

Typical Isometric Drawings and Schematic Diagrams

Typical MotorGuard drawings are provided on the following pages. These drawings provide general information describing your MotorGuard filter. More specific information is provided by the drawings shipped with the unit. Be sure to carefully review the information provided by these drawings. This information takes precedence over the information provided in this manual.

Isometric Drawings

The isometric drawings provide three-dimensional representations of the MotorGuard units. Three drawings are provided to cover units that are constructed on small, medium, and large size panels. The rating and dimension tables list the dimensions for the various models. Two additional drawings are provided to show the power wiring connection detail.

Schematic Diagrams

The schematic diagrams show the details of the MotorGuard circuitry. Two diagrams are provided. The diagram for the small size units shows the power block that is provided for input and output motor power wiring connections. The diagram for the medium and large size units shows input and output motor power wiring connected to terminals on the 3-phase reactor.

KMG – Capacitor connection may be WYE, consult factory

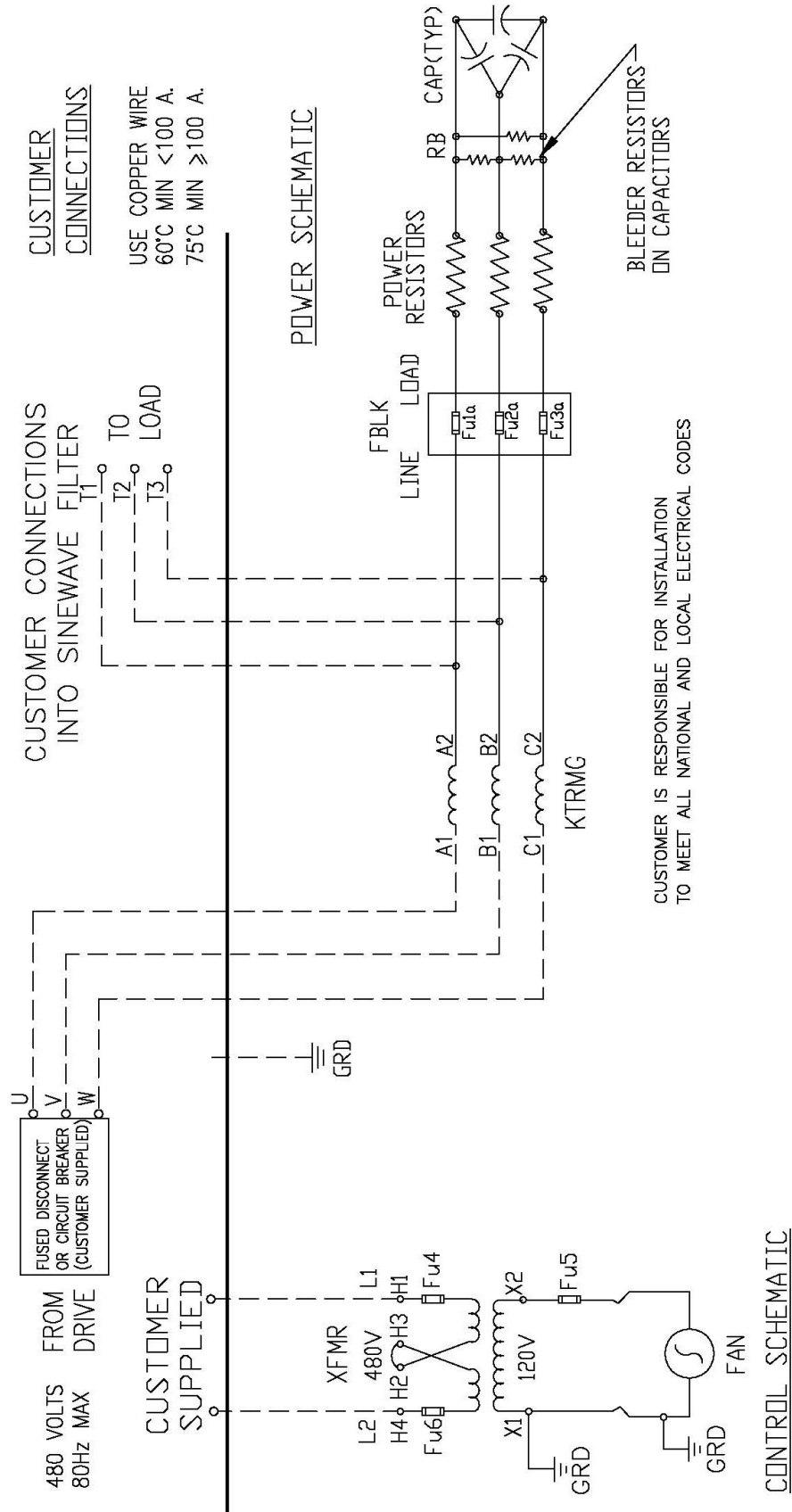

CUSTOMER CONNECTIONS
 USE COPPER WIRE
 60°C MIN <100 A.
 75°C MIN ≥100 A.

CUSTOMER CONNECTIONS
 INTO SINEWAVE FILTER

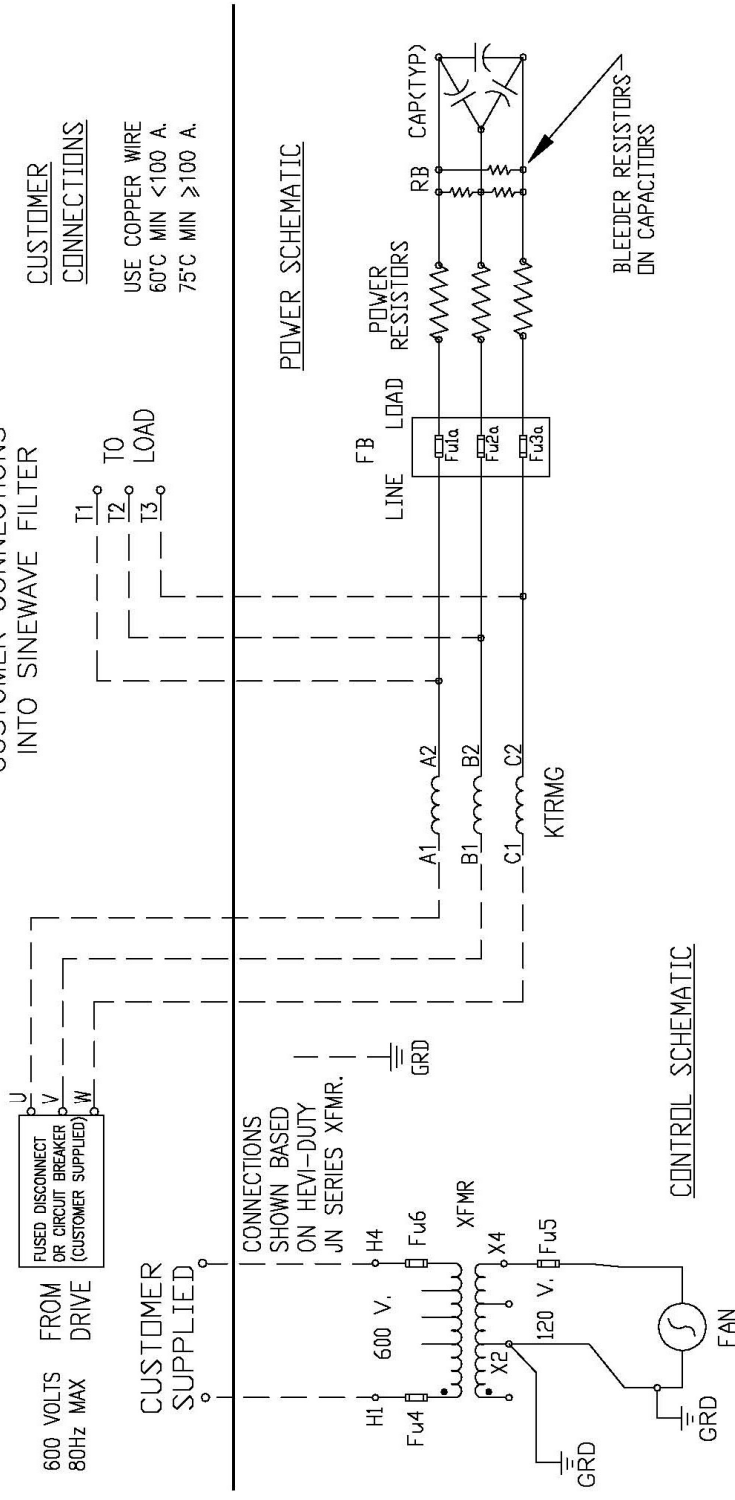

BLEEDER RESISTORS
 ON CAPACITORS

CONTROL SCHEMATIC

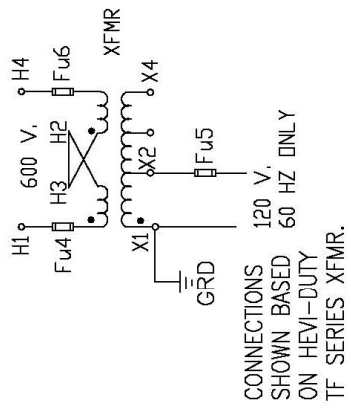

CONNECTIONS
 SHOWN BASED
 ON HEVI-DUTY
 ON HEVI-DUTY
 TF SERIES XFMR.

CUSTOMER IS RESPONSIBLE FOR INSTALLATION
 TO MEET ALL NATIONAL AND LOCAL ELECTRICAL CODES

KMG with Board Option

5HP TO 40HP
8AMPS TO 55AMPS

CUSTOMER CONNECTIONS

USE COPPER WIRE
60°C MIN <100 A.
75°C MIN >100 A.

CUSTOMER CONNECTIONS INTO SINEWAVE FILTER

CUSTOMER SUPPLIED SERVICE DISCONNECT WITH OVERCURRENT PROTECTION

CUSTOMER SUPPLIED VARIABLE FREQUENCY DRIVE

CUSTOMER SUPPLIED

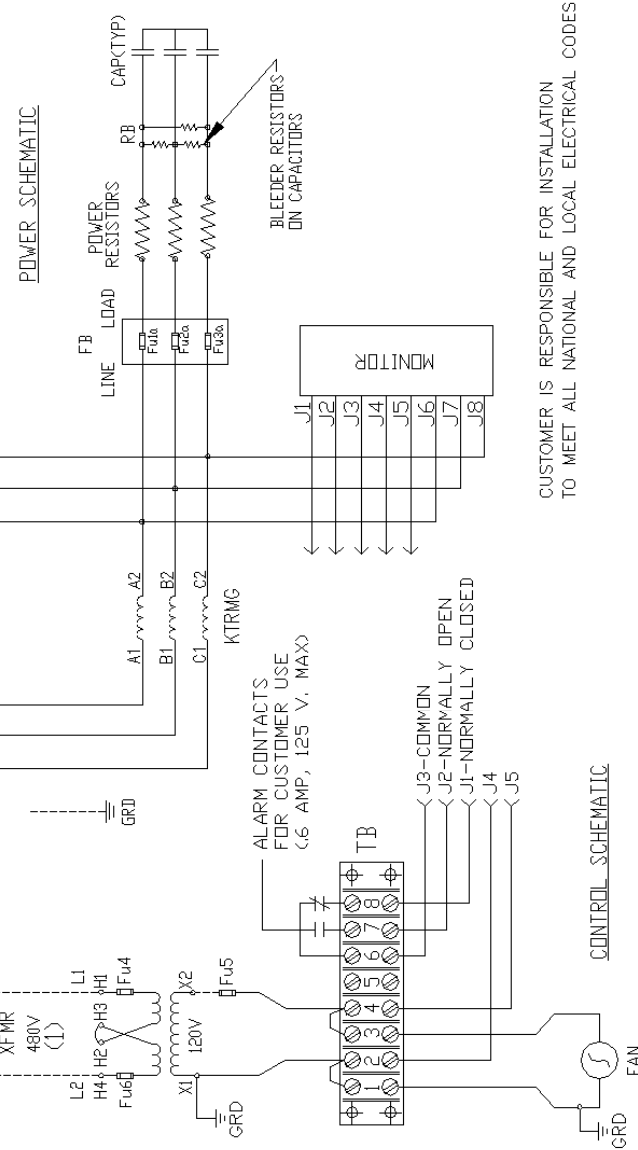
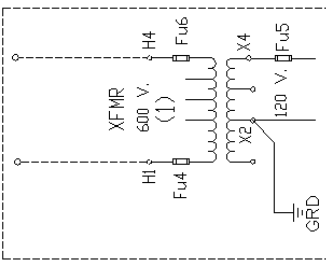

CUSTOMER IS RESPONSIBLE FOR INSTALLATION TO MEET ALL NATIONAL AND LOCAL ELECTRICAL CODES

CONTROL SCHEMATIC

(1) SEPERATE SINEWAVE POWER OF 480 OR 600 VOLTS DEPENDING ON SYSTEM LINE VOLTAGE, SEE MANUAL FOR DETAILS.

NOTE: DO NOT CONNECT CPT TO THE VFD OUTPUT.

KMG with Board Option

50HP AND UP
65AMPS AND UP

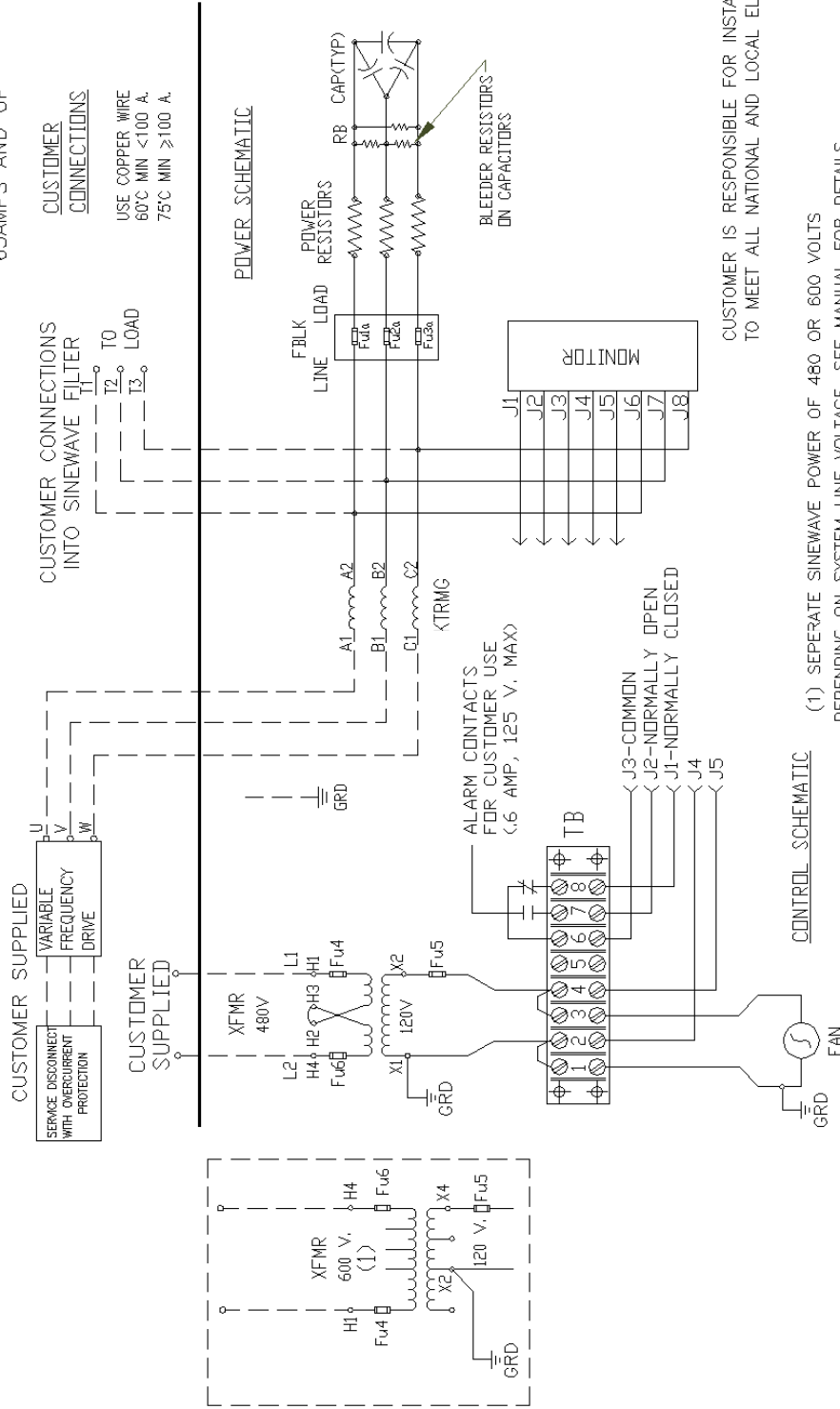

(1) SEPERATE SINEWAVE POWER OF 480 OR 600 VOLTS
DEPENDING ON SYSTEM LINE VOLTAGE, SEE MANUAL FOR DETAILS.

NOTE: DO NOT CONNECT CPT TO THE VFD OUTPUT.

CUSTOMER IS RESPONSIBLE FOR INSTALLATION
TO MEET ALL NATIONAL AND LOCAL ELECTRICAL CODES

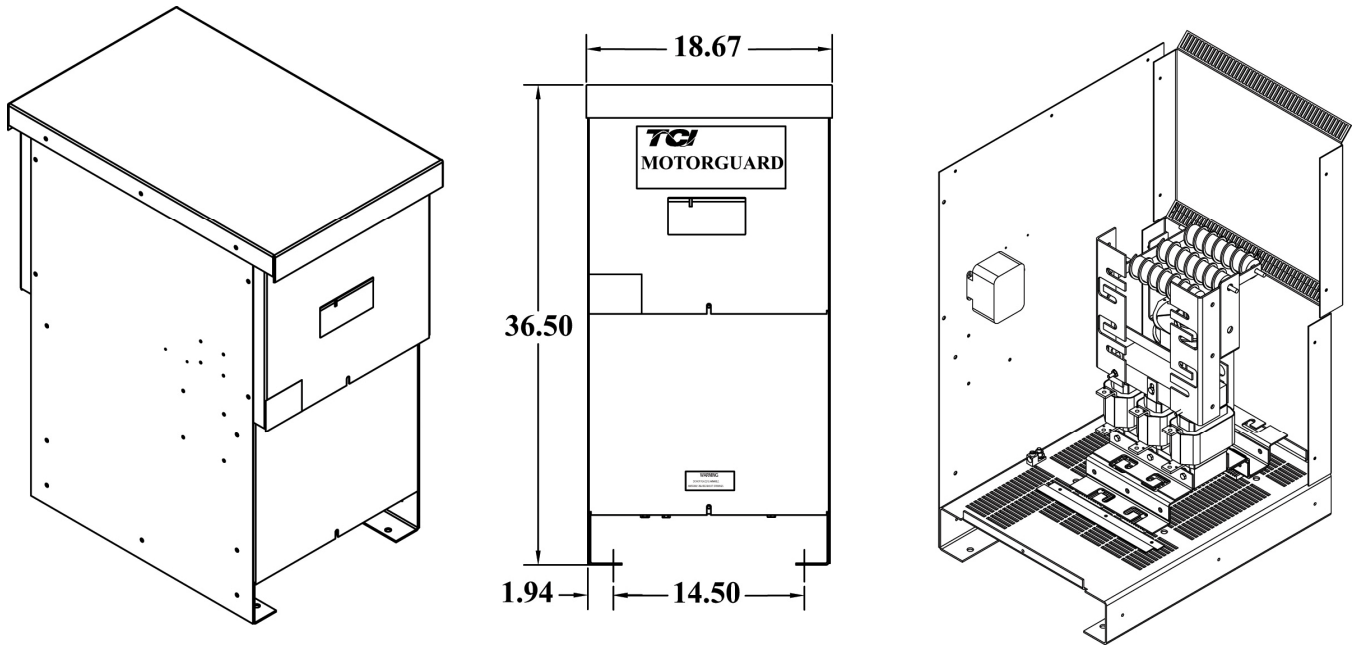

KMG GP NEMA 3R – Small enclosure

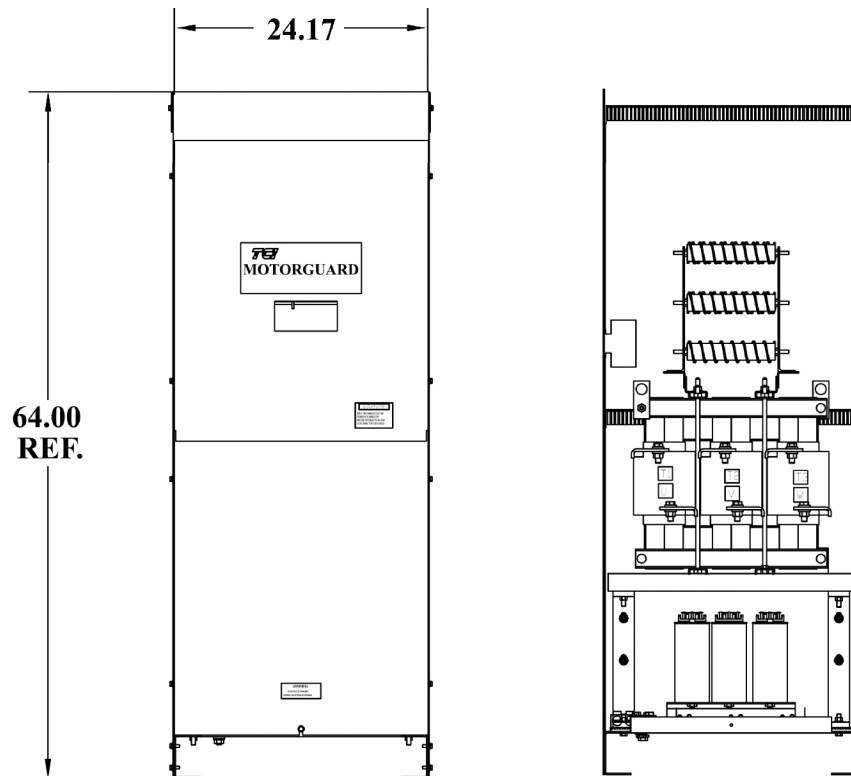

KMG GP NEMA 3R – Large enclosure

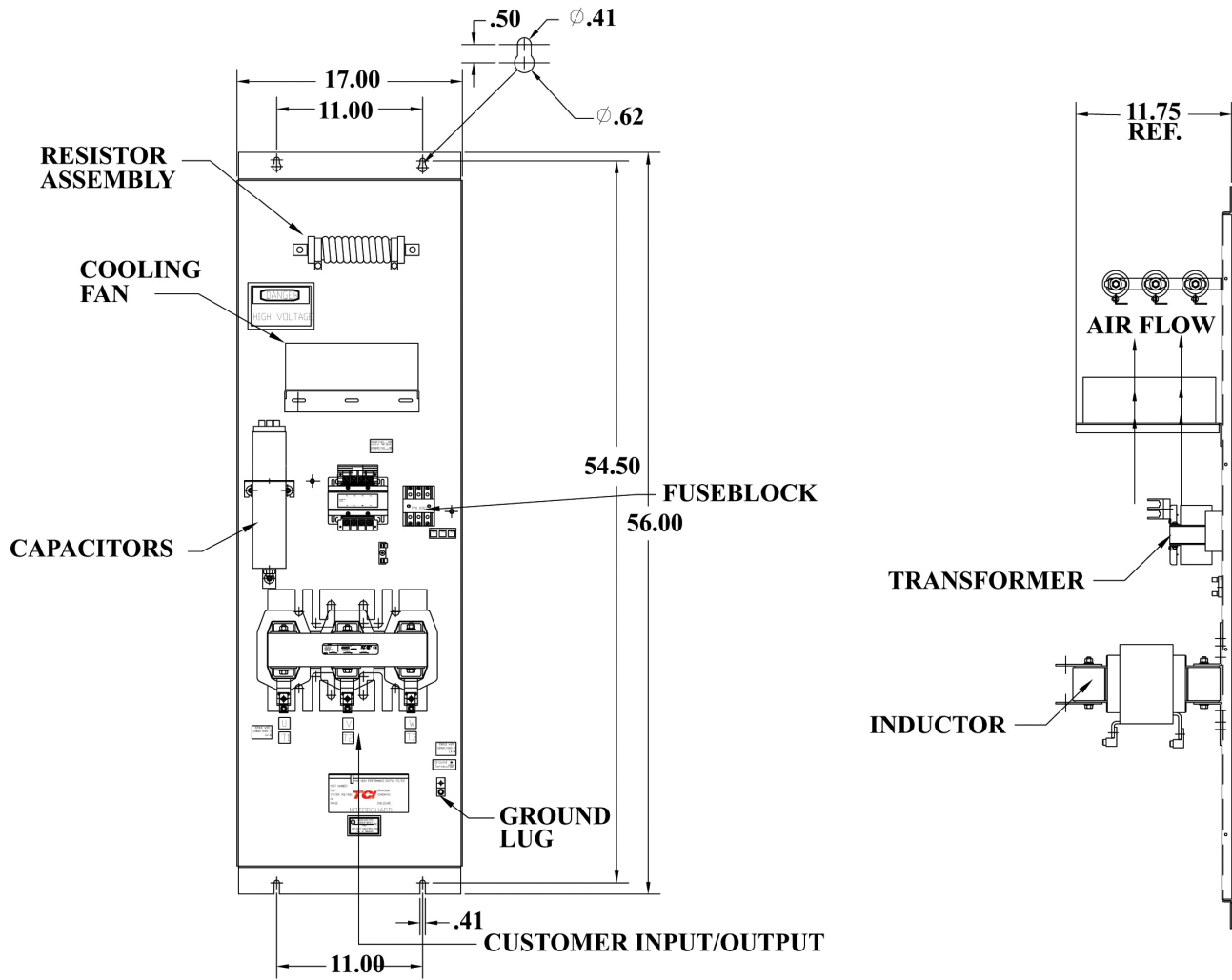

KMG Industrial Filter Open – Medium enclosure

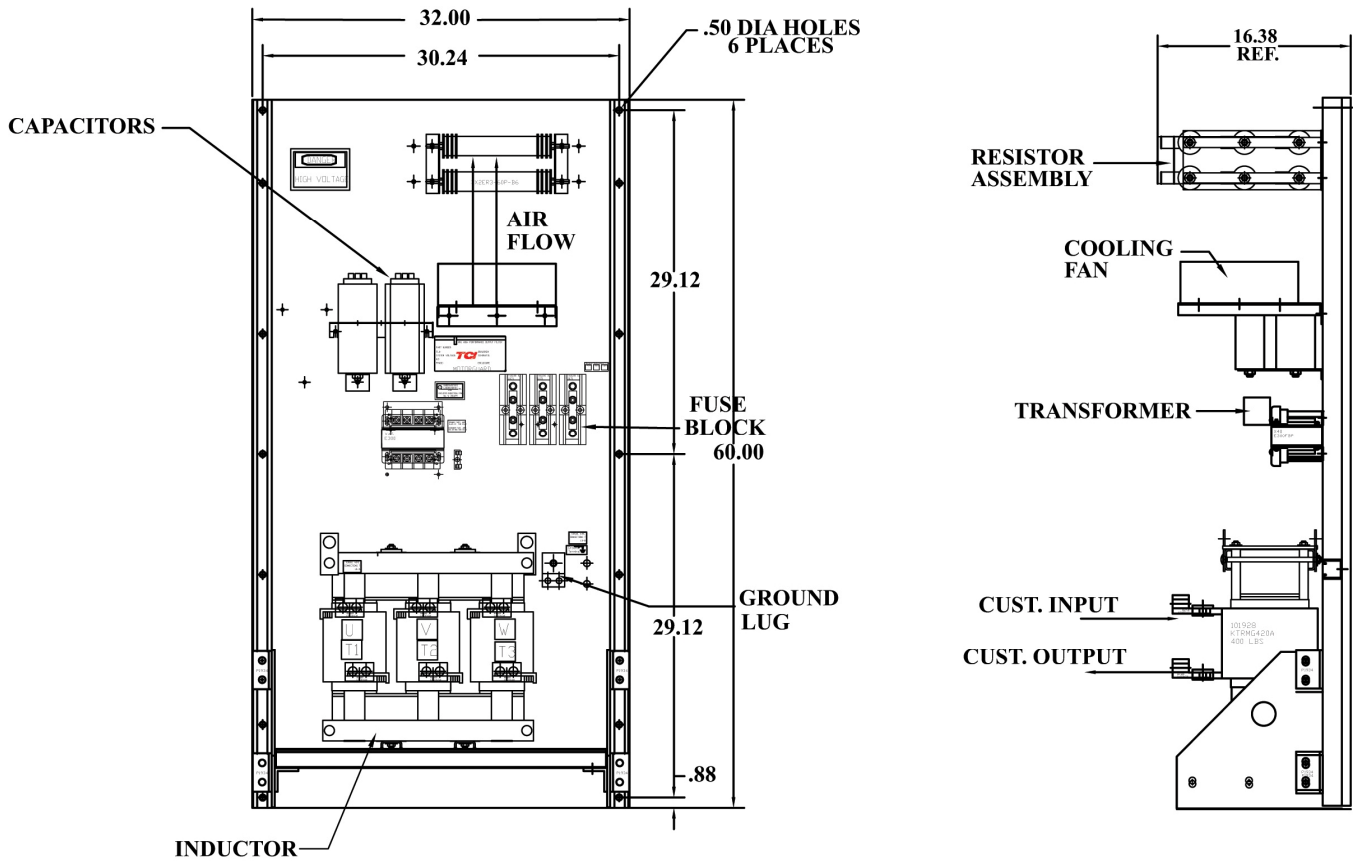

KMG Industrial Filter Open – Large enclosure

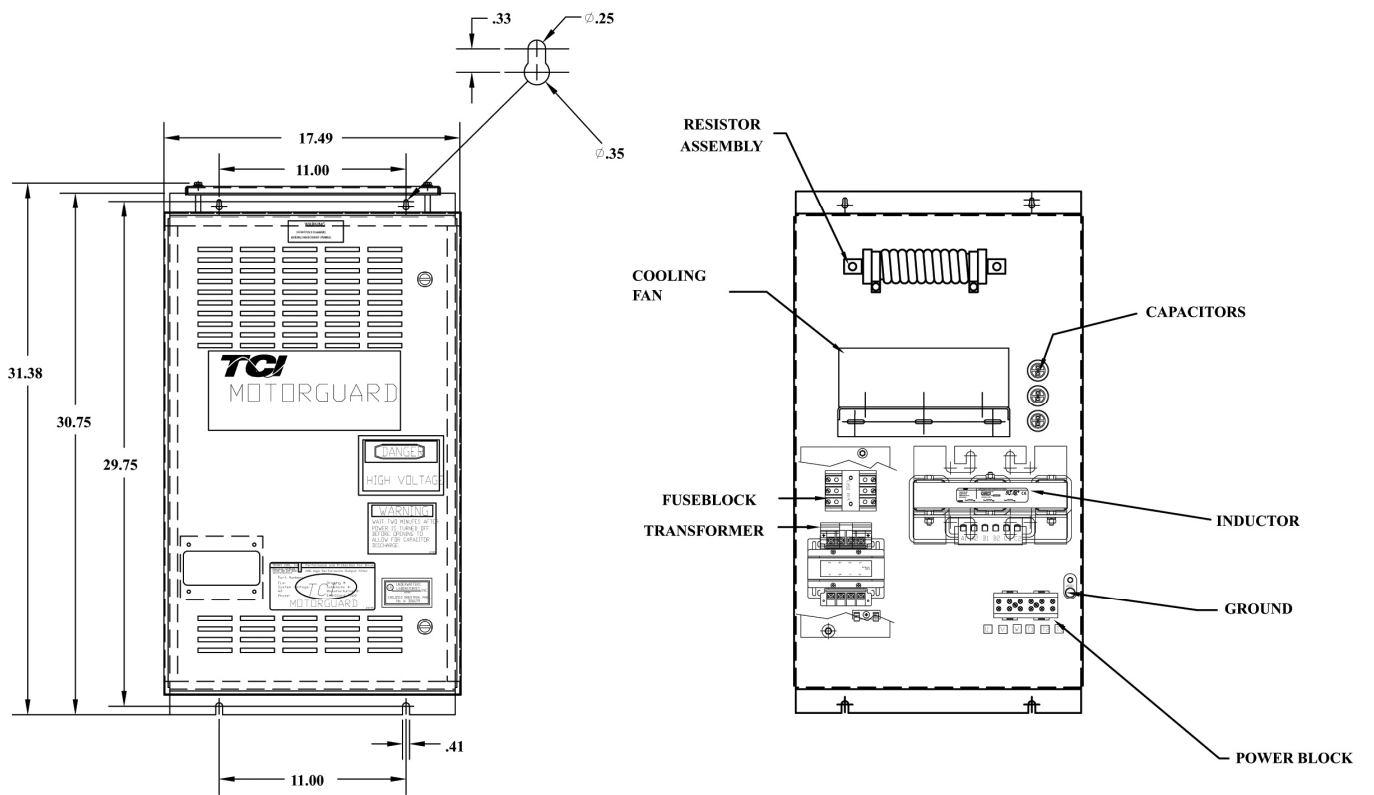

KMG Industrial Filter Type 1 enclosure – Small enclosure

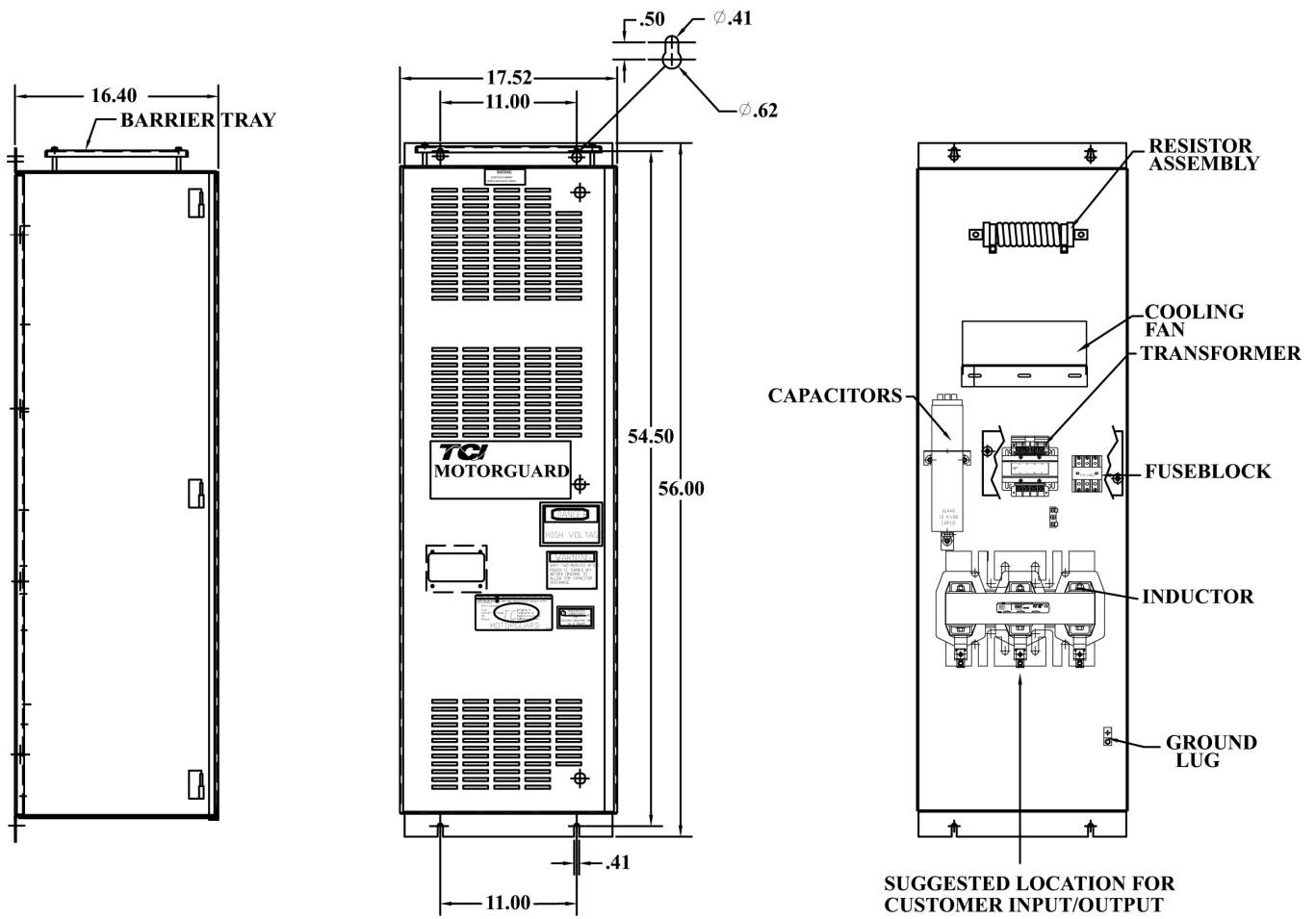

KMG Industrial Filter Type 1 enclosure – Medium enclosure

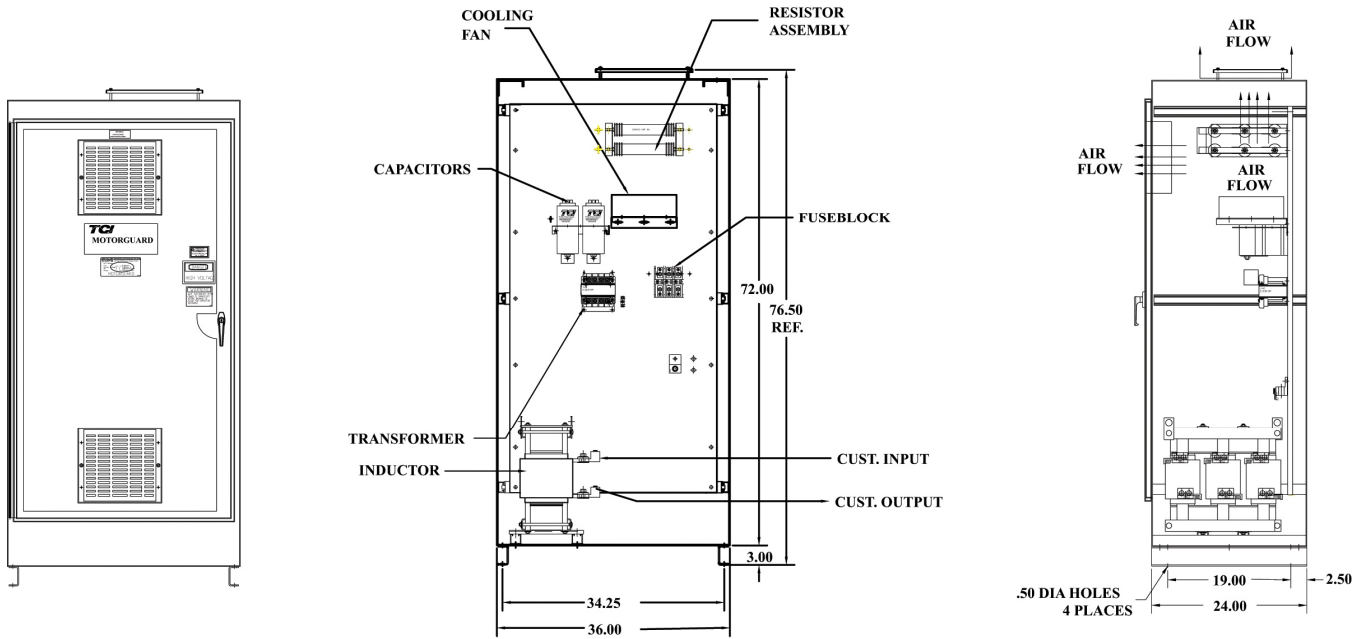

KMG Industrial Filter Type 1 enclosure – Large enclosure

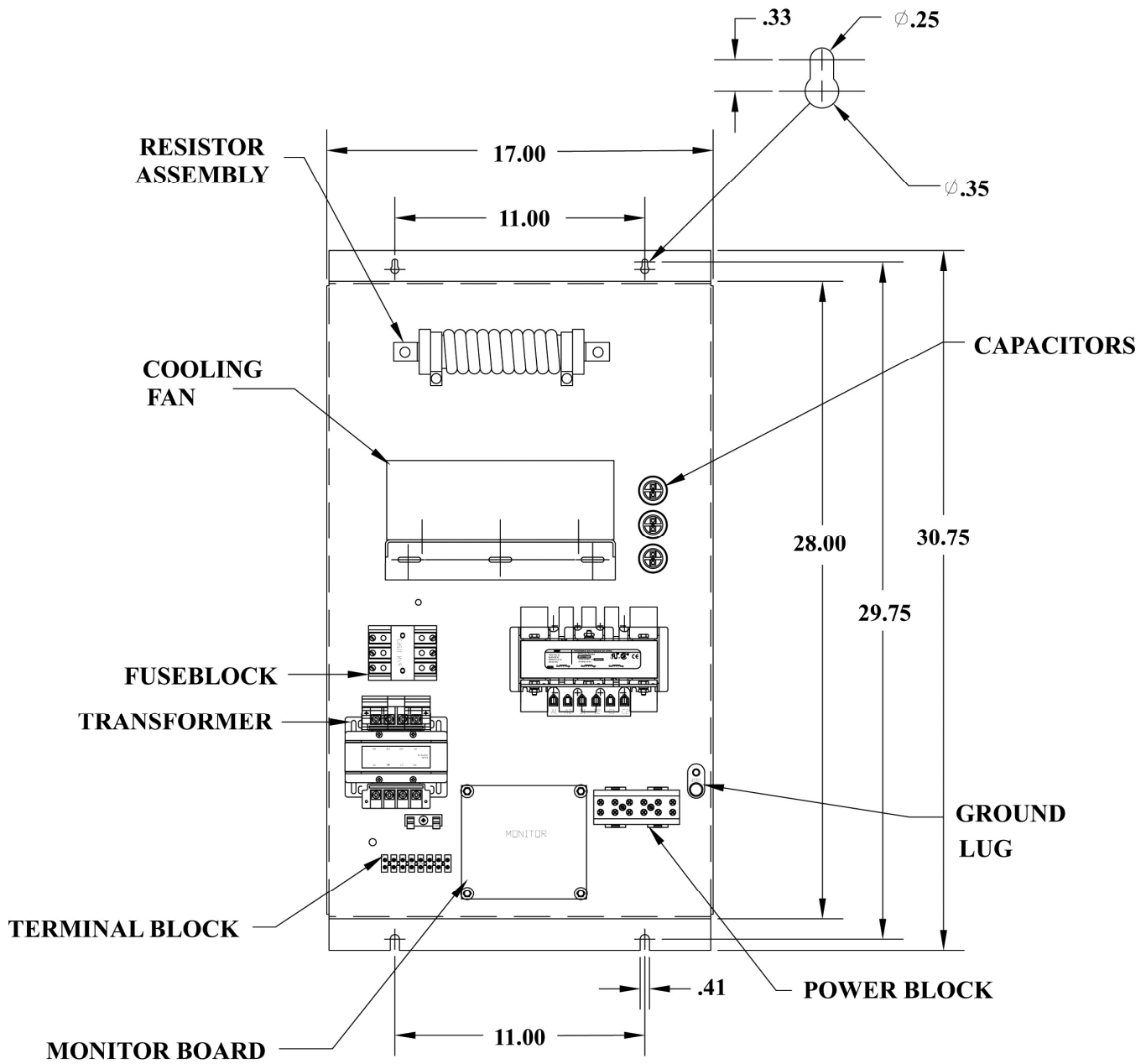

KMG Industrial Filter with Monitor Board Option (Shown in a small enclosure)



TCI, LLC
7878 N. 86th Street
Milwaukee, Wisconsin 53224

Phone: 414-357-4480
Fax: 414-357-4484
Helpline: 800-TCI-8282

Web Site: <http://www.transcoil.com>