



# Industrial automation AC500 for PLC solar systems



# Unlimited clean energy with zero emissions

By converting solar energy into electrical energy, for each kWh generated, carbon dioxide (CO<sub>2</sub>) emissions that pollute the planet can be reduced by 600 grams.

Solar energy is clean, unlimited and safe. Even when it is converted into electricity through Photovoltaic or Concentrated Solar Power plants, it does not produce harmful emissions.

That is why this renewable energy source is assuming a key role in the future of energy policies. Many governments support incentive plans to promote generation and integration of energy into the grid by means that minimize the environmental impact.

Utilities, banks, capital ventures and other players investing on solar power generation face a common challenge: capturing solar energy, a natural and unlimited source of heat and light, through solutions that can efficiently transform it into reliable and profitable electricity.

# Efficient solutions to improve Solar power

ABB solutions for solar power plants are designed to maximize performance output and provide owners with a rapid return on investment and a long plant operating life, generating around 15% more energy than other solutions.

## Precision control of solar tracking systems

ABB has developed solutions based on programmable logic controller (PLC) that enables collectors, mirrors and panels to capture maximum energy with unparalleled accuracy.

Exceptionally robust, the solutions are designed to withstand extreme environments of intense heat and cold, as well as dust, erosion and mechanical stress.

The AC500 PLC uses high-precision solar algorithms to ensure that all type of trackers, for either PV, CPV or CSP, are precisely aligned and follow the movement of the sun with exceptional accuracy.

This, together with the easy-to-use ABB library for solar applications and the unique scalability of the AC500, makes the solution adapted for all your control and automation needs.

The AC500 performs all control tasks linked to open and closed loops, monitors the tracking of the sun, and includes options like:

- Calculating the path of the sun
- Registering and assessing the sensors connected (anemometers, pyranometer, etc.)
- Placing the panels in a safe position if weather conditions deteriorate
- Manual positioning mode
- Calibration mode
- Remote data transmission.

ABB motors and variable speed drives enable the trackers to perform the movements determined by the PLCs with minimal energy consumption.



# Photovoltaic and thermosolar systems

Every hour, the earth absorbs more solar energy than the world's population in a year.

The use of PV systems to produce energy is spreading world-wide. Solar systems are easy to install, not very difficult to operate and useable almost everywhere.

Applications vary from small fixed systems for domestic and commercial use, to solar parks with either fixed PV cells or modules tracking the sun.

Technological developments have kept pace with the growing demand for PV systems. Thanks to its wide range of products, ABB plays an effective and sustainable role as solution provider.

The efficiency of solar-tracking PV systems mounted in either one axe (azimuth) or two axes (azimuth and elevation) structures requires adapted solutions to every need, which in the case of ABB are performed always using standard products.

With its extensive experience in all sectors of energy and its comprehensive range of products, ABB is a qualified supplier of devices and systems for applications in the field of renewable energy.

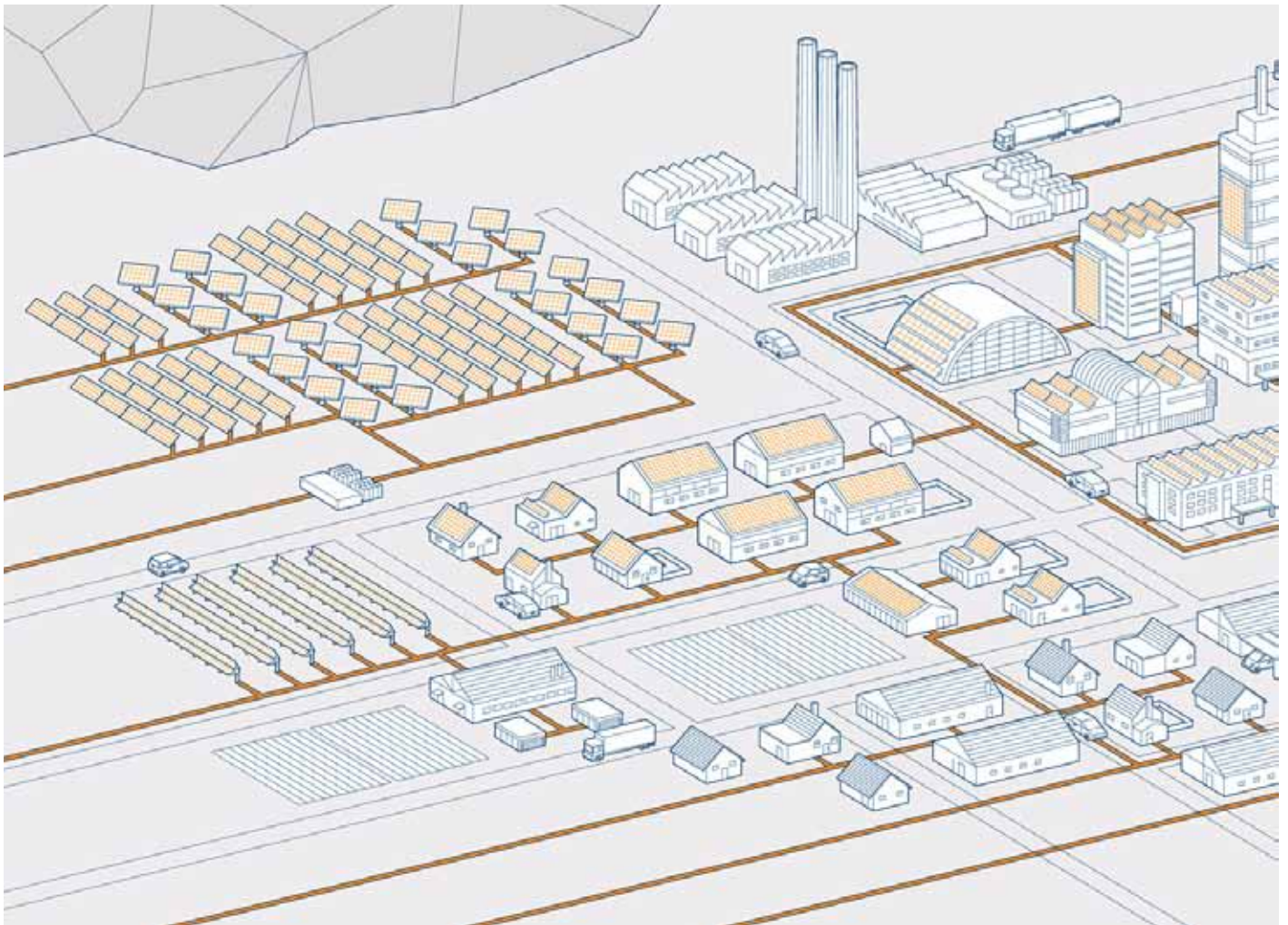



### Increased number of thermosolar plants in areas directly exposed to sunlight

Some governments have taken steps to boost the development of renewables including the promotion of thermosolar plants. This technology has shown that it can guarantee a high output and efficiency compared to traditional solutions, thereby resulting

in growing interest from other countries. One of the basic requirements of a thermosolar plant is its ability to follow the position of the sun accurately, which is reflected in the plant's output. ABB solutions take all needs into account to offer their clients products and systems which are suited to their requirements.

The AC500 sets the trend: ABB guarantees that the use of suitable automation components, such as the scalable PLC AC500, maximizes the effective use of sunlight. Depending on the technology, PV, CPV or CSP and the design, AC500 offer precisions in both azimuth and elevation of  $0,0003^\circ$ , among the most accurate in market.



# State of the art technology for high performance applications in solar power

## Save more energy from a single source

ABB product range comprises all components needed for an efficient operation and maintenance of a solar-PV system regardless of its size

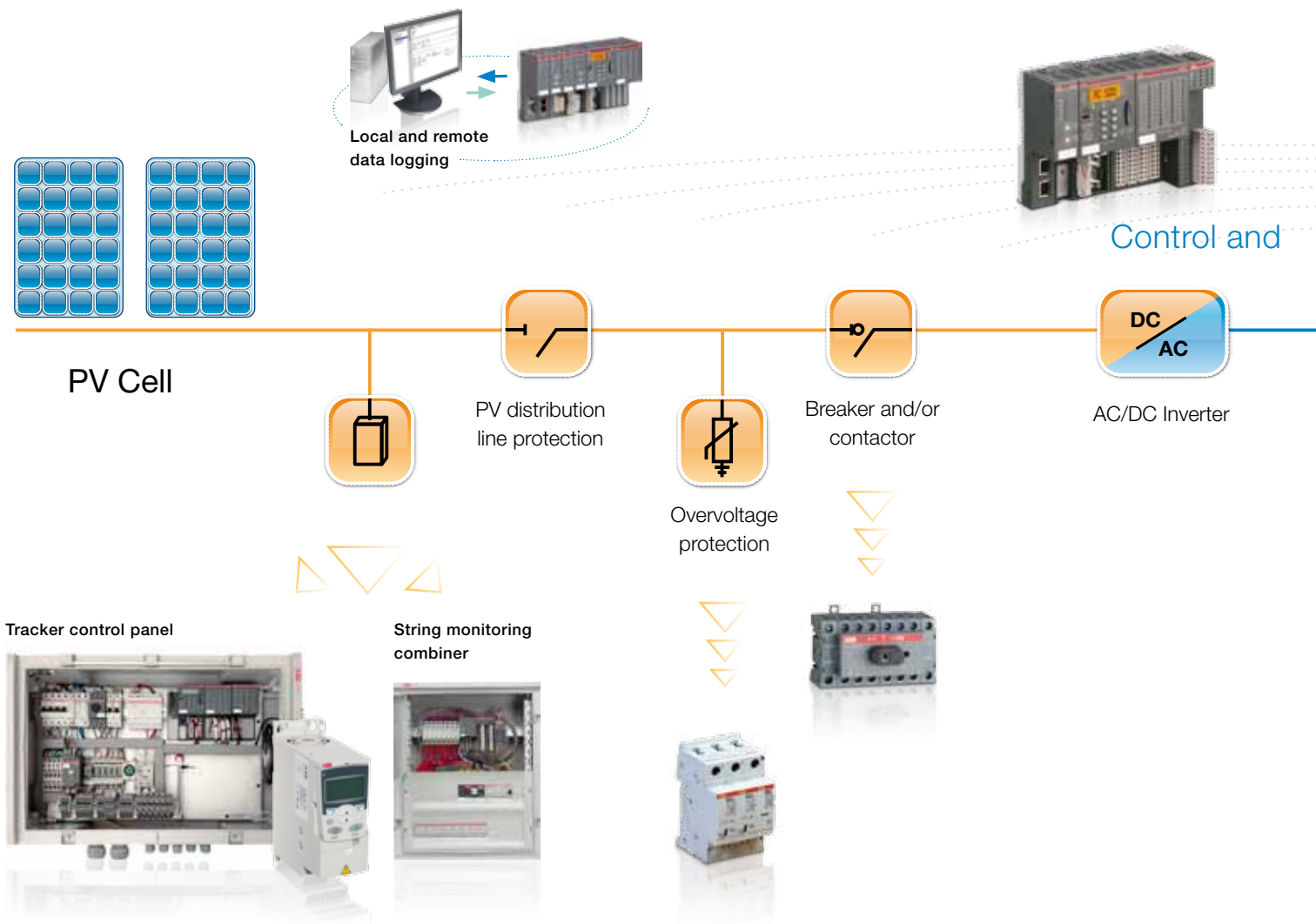

### Always the right solution

So that the solar trackers are following the position of the sun during normal operation, and when it is windy or even snowing, an instruction is sent to go to a secured position.

### The monitoring system

To maximize the performance ratio of a photovoltaic installations experts promote and recommend the use of monitoring systems for both current and voltage of string arrays, with the aim of keeping the owner informed and fully aware about the performance and the productivity of the system through the years.

### The data-logging system

Retrieve and store data when needed is very important to have up dated information about the installation behavior and performance. Early warnings can save money acting on time with oriented and focused maintenance actions.

### The control system

ABB always has suitable automation solutions thanks to the scalable PLC AC500, which is based on a modular design that incorporates CPUs, communication modules and I/O modules. Furthermore, the system can be easily expanded when required. The function blocks and standard programming ensure that the user can gain instant control, which is especially useful after changes to the system have been made.



visualization

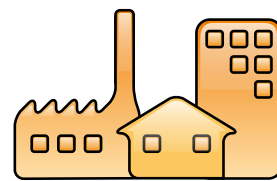
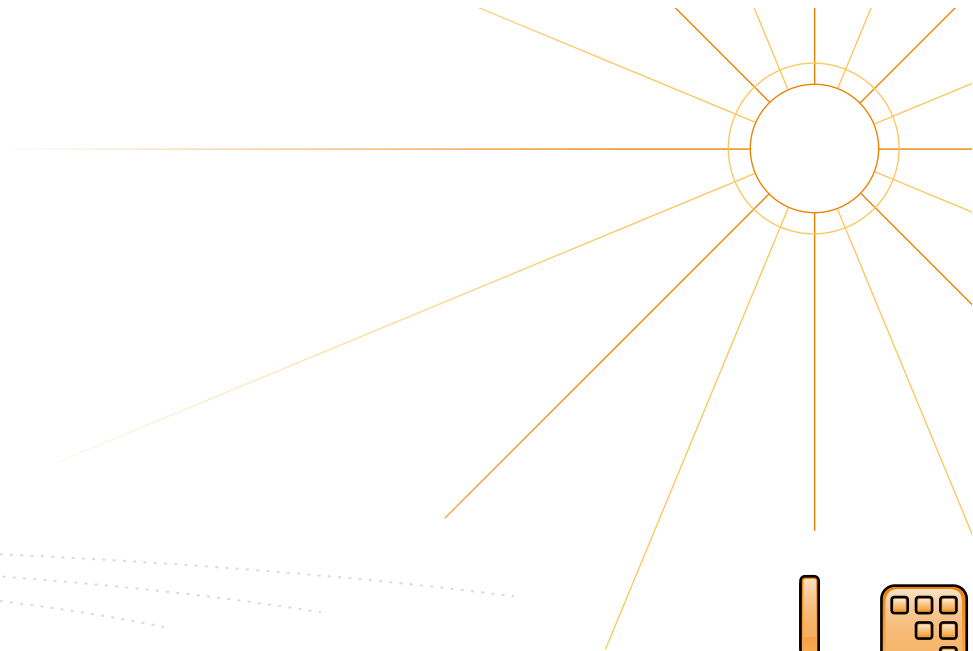

Switch



Overvoltage protection

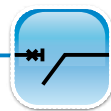

Breaker and RCD protection



### The operator panel

ABB has a wide selection of touch screen operator panels in many different sizes and which are simple to use and reliable.

### Change-over components

In addition to the scalable AC500 control unit, ABB has also change-over components such as connectors, interrupters, cutouts, power switches, relays, motor-protection switches, and high performance automatic circuit breakers.

### Converter technology

ABB is a leader in the global converter technology market. In this sector, we have a wide range of frequency converters, power inverters, servo drives, servo motors and motors.

### Wherever you need us

The services and technical assistance provided by ABB worldwide make it a reliable partner for manufacturers and users who can rest assured that their investments are protected over the long-term. ABB runs seminars and special training courses on many of its products and systems, including automation systems and application oriented trainings

# Solutions and packages to enhance photovoltaic and thermosolar systems

## Get more with the scalable PLC AC500

### Suited to your needs

Standard hardware fitting to all your needs:

- Different types of CPU's from 128 Kby to 4 Mb memory
- All CPU types are programmed with the same programming tool
- A unique high density mass storage CPU (PM592) offering 4GByte memory for data logging applications
- Optional SD cards to save data
- Communication modules which can be added in any combination (up to four for each CPU), offering following communication protocols: Modbus RTU, Modbus TCP (with integrated switch), CANopen, Profibus DP, ProfiNet and EtherCat
- Configurable I/O modules (digital and analog) to optimize your solution and thereby make maintenance cheaper
- Various function blocks in our dedicated solar library processing date and time of the day and local coordinates to calculate values needed by control panels, actuators, mirrors or heliostats, including Solar Position Algorithms based on NREL and NOAA calculations.



### PS562-SOLAR

#### Solar tracker solution library

- Library for solar tracking applications enabling fast engineering, especially together with ABB's drives and motors
- Covers different tracker configurations and different algorithms for accuracy needs
- Control of trackers in parabolic trough, power tower, PV and CPV applications.

Complete library package for different tracking use cases, plug and play:

Example program with detailed explanations and visualizations

- Control of the tracker adaptable to different needs and conditions, to achieve maximum efficiency of installation
- Exact positioning of different axes with the following accuracies:
  - NOAA algorithm 0.03 Grad
  - NREL algorithm 0.0003 Grad.
- Input / sensor adaptation
- Communication
- Different actuators / drives control
- All needed modes for simple commissioning and manual operation
  - Fast and simple calibration of the trackers, offering manual repositioning and fine tuning
  - Safety positions
  - Back tracking.

#### How to get the Library

- Separate package with self installing software and with license code.

#### Target Systems

- NOAA: PM554 and above
- NREL: PM573 and above.

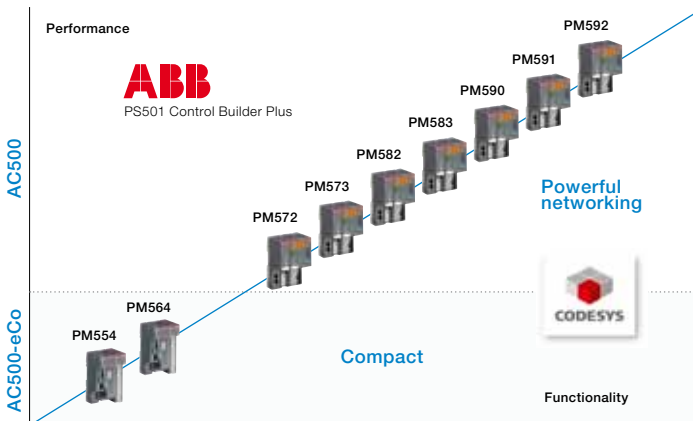

### Ideal for Data Storage and data logging systems

- Built-in flash-disk, non-removable
- Flash Disk 4096 MByte mass data storage
- Immune to vibration and theft
- Fast access
- Physical size of module remains same
- FTP for remote access to mass data.







### Designed to be 100% reliable

Other advantages that come with the AC500, which you can enjoy from the outset:

- Homogenous programming in compliance with standard IEC 61131-3 available in five languages
- Worldwide supply
- Global assistance and services
- Wide range of certificates
- Standard automation platform by acknowledged expert in the fields of automation and energy technology.



### Operating in wet environment

- Increased resistance to 95% humidity.



### Use at high altitudes

- Operating altitude up to 4,000 m above sea level.



### Extended immunity to vibration

- 4 g root mean square random vibration up to 500 Hz
- 2 g sinusoidal vibration up to 500 Hz.



### Extended EMC requirements

- EN 61000-4-5 surge immunity test
- EN 61000-4-4 transient / burst immunity test.



### Extended operating temperature

- -30 °C up to +70 °C operating temperature
- reliable system starts at -40°C.



### Extended immunity to hazardous gases and salt mist

- G3, 3C2 immunity
- Salt mist EN 60068-2-52 / EN 60068-2-11.

# ABB Solutions to improve operation and maintenance in solar power plants

## ABB solutions help you to enhance commissioning and reduce maintenance costs

Thanks to the unique “Multi Online Change” tool integrated in our PLC programming tool you can perform multi-online changes up to 1000 PLCs connected to the network simultaneously, from one single point, reducing drastically commissioning time and update set ups.

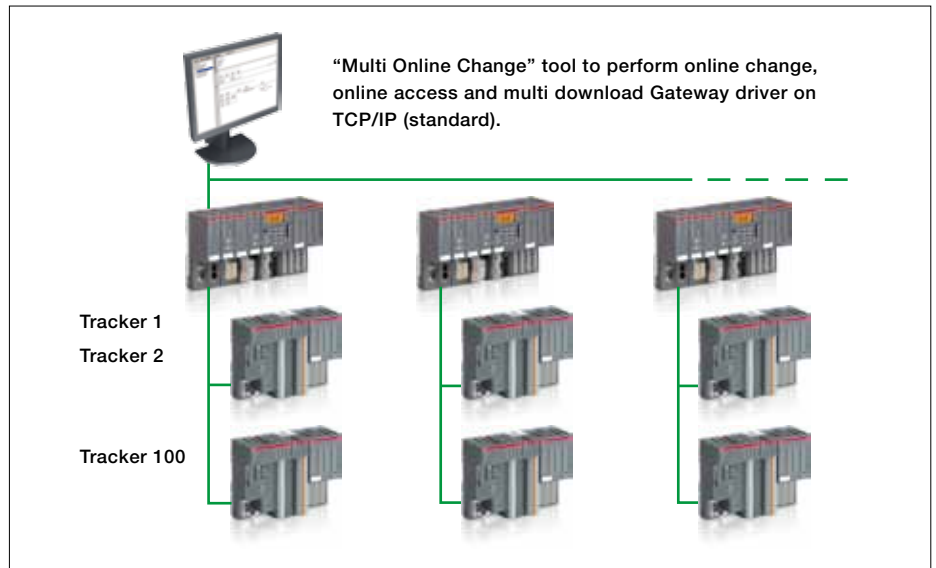

## ABB solutions help you to be connected with your installation at the lowest possible investment

Thanks to the web server tool integrated in the PLC you do not need local computers to visualize, store and retrieve data from your installation. In addition, AC500 platform offers FTP server and FTP client functions.

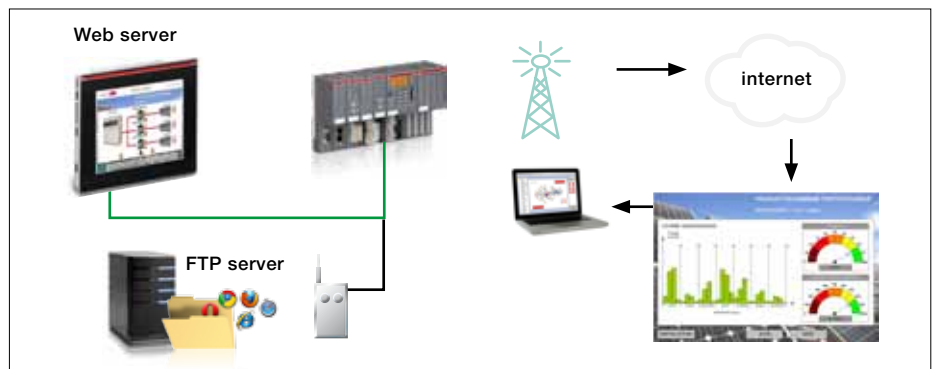

## ABB solutions help you synchronize your system with accurate time information

Thanks to SNTP protocol, all CPU's in your installation are constantly synchronized to the time server of your choice.

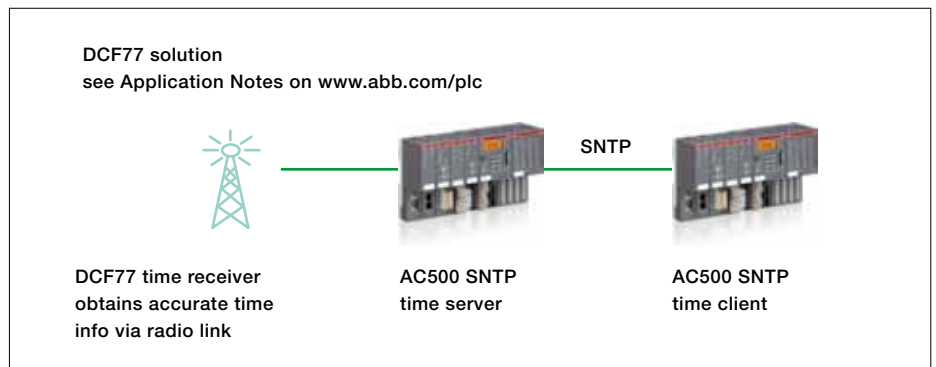

## ABB solutions help you to access MySQL data bases in a simple and easy way

MySQL is a powerful standard database enabling powerful reports and flexible data export. ABB PLC writes data directly into the database thanks to a ready to use library. No need of DynDNS function is required for the communication.

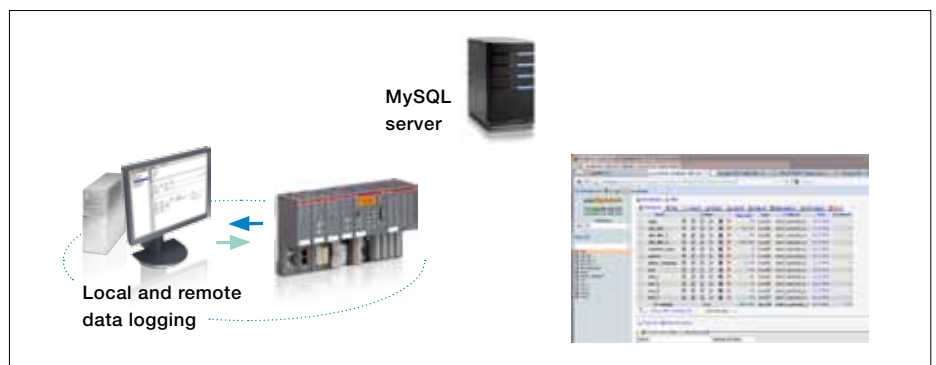

### ABB tracker control solutions

Thanks to ABB solar library and ABB large product assortment, solutions for all solar trackers designs used in all solar application, as PV, CPV, Parabolic Trough, Power Tower and Dish Sterling can be performed, granting high performance and benefits to the customer at a reduced and cost effective investment.

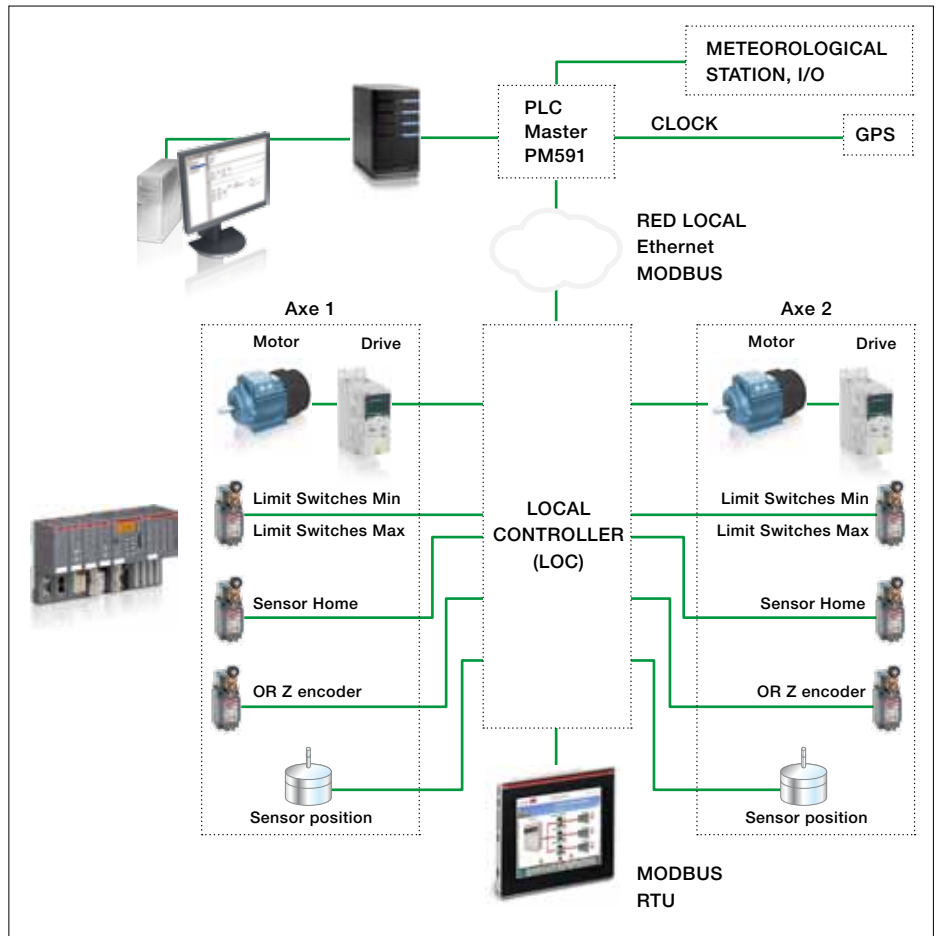

### ABB String monitoring solution

The use of standard PLCs instead of dedicated boards, guarantees high availability of spare parts over time and a mature and reliable technology. The control system based on ABB String combiners and AC500 enables full visualization of the plant parameters: from the efficiency of the single string, inverter data, information from medium and low voltage cabinet switches in both AC and DC side.

The data collected by the system can be viewed, analyzed and chronologically organized via WEB. The application can be freely developed by the user. Thanks to the great flexibility of the ABB PLC interface, the monitoring system can be easily integrated into existing supervision systems.

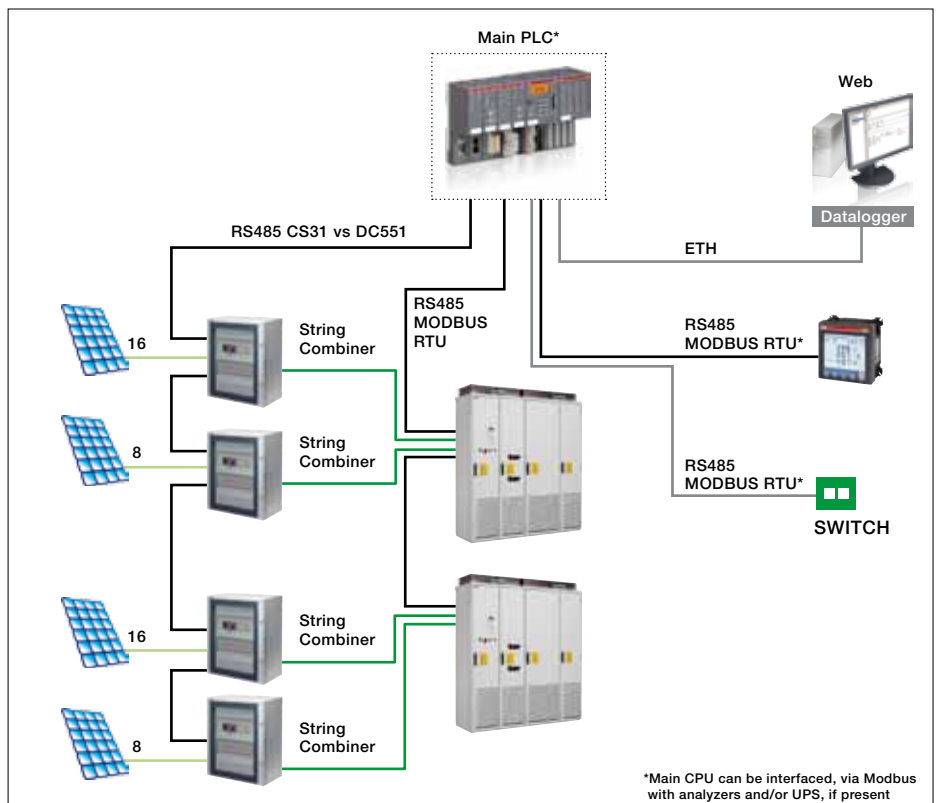

# Energy management of PV power plants

## Full monitoring system for Solar PV installations aimed to provide supervision, control and real time energy production monitoring

One main CPU gather the data, alarms and faults, from several devices spread out within the field in different areas, like inverter rooms, power stations, control room, etc. using standard communication field buses like Modbus and IEC telecontrol protocols like IEC 60870-5-104. All this information can be stored in the webserver area of the controller to be retrieved by local or remote SCADA system.

## A typical web server application in the controller can manage:

- Devices status, like breakers, substation relays, etc
- Mesures, string current and inverter data
- Cumulated information for power and energy
- Histogrammes representation
- Acces management
- Manage the data stored in either the SD Card or the flash memory of the controller
- Make FW and user program up dates.

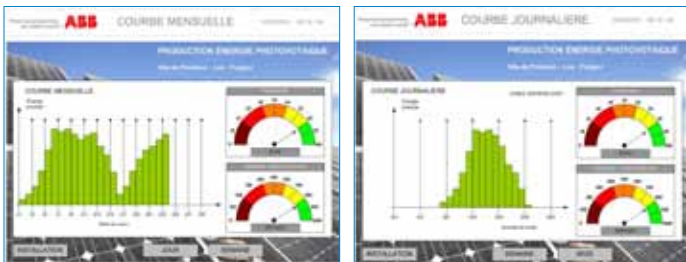

## RTU & SCADA applications for Photovoltaic Power Plants

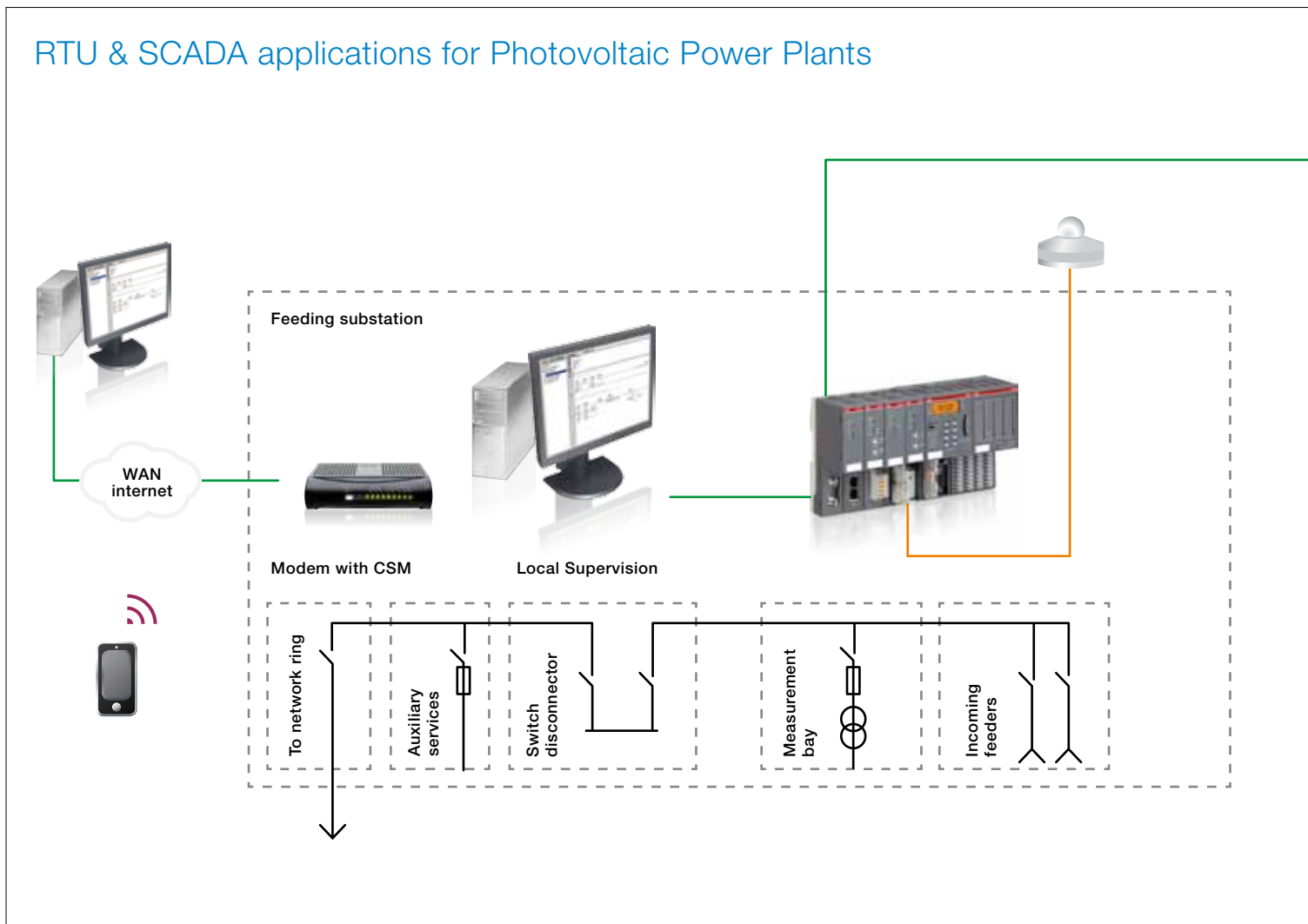

**Typical features of Supervision systems from ABB like Compact HMI, System 800xA and Symphony Plus are:**

- Process Graphics
- Alarms, Trending and History
- Audit Trail
- SMS & Email Messaging
- Calculations
- Report Generation/Snapshot Reports
- Remote Client/Monitoring
- Bulk data handling.

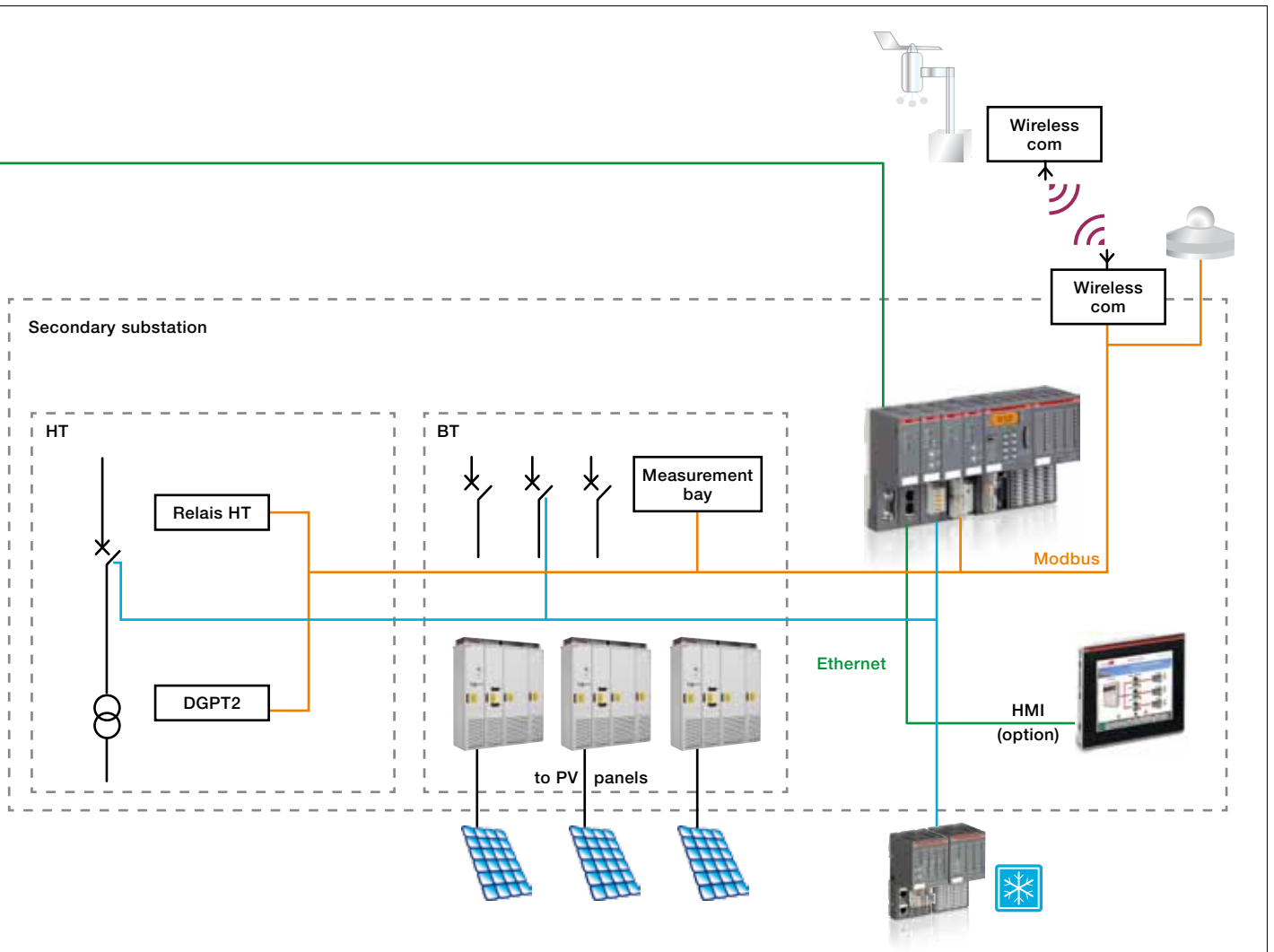
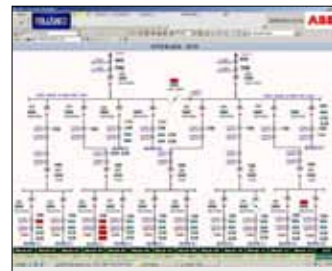

# Helping our customers achieve their targets

## La Robla photovoltaic power plant, 13.3 MW, Spain

The solution is based on ABB's uniquely efficient concept for PV power plants, an approach that combines a high level of customization, rapid turnkey delivery and system optimization technologies that enable the plant to generate around 15% more energy than other designs.

ABB installed automation technologies including tracker controlled by 320 AC500 systems to maximize power output capacity.

## El Cannino photovoltaic power plant, 24 MW, Italy

ABB designed, engineered, erected and commissioned the plant. ABB's modular EBoP (electrical balance of plant) concept enables fast track execution within four months. The 24.2 MW plant is based on single-axis trackers, which precisely follow the position of the sun to position PV panels at the best angle for maximum energy production. ABB installed automation technologies including trackers controlled by 350 AC500 systems to maximize power output capacity.

ABB supplied all electrical equipment required to connect the plant to the grid, including medium and low voltage switchgear, transformers and a medium voltage substation.

## As of beginning 2012 ABB had more than 300 MW installed in PV using AC500 solution for:

Energy management and/or, tracker control and/or string monitoring, in countries like: Italy, Spain, India, China, France.

## ABB rooftop photovoltaic plant, Finland

Located on the rooftop of the ABB Drives factory in Helsinki, Finland, the installation is the largest solar power plant in the Nordic countries. The 181 kW plant generates about 160,000 kWh per year and benefits from the long summer days of its northern latitude. The ABB solution comprises ABB string inverters and one central inverter connected to the building automation system.

## Extresol 1 & 2, Concentrated Solar Power, 50 MW each, Spain

The solution encompasses an extensive array of power and automation products and systems for the 100-megawatt (MW) Extresol 1 & 2 solar thermal power plant and solar collector field in Extremadura, western Spain.

Extresol 1 & 2 produces 50 MW of electricity each from a vast solar field of parabolic trough collectors covering more than 750,000 square meters, equivalent in size to around 100 soccer fields.

The solution also includes 624 AC500 systems per 50 MW power block equipped with advanced solar positioning algorithm especially developed by ABB for parabolic trough collectors and solar trackers.

## As of beginning 2012 ABB had more than 400 MW installed in CSP using AC500 solution for:

Parabolic Trough tracking control, in countries like: Spain, United States of America, China.

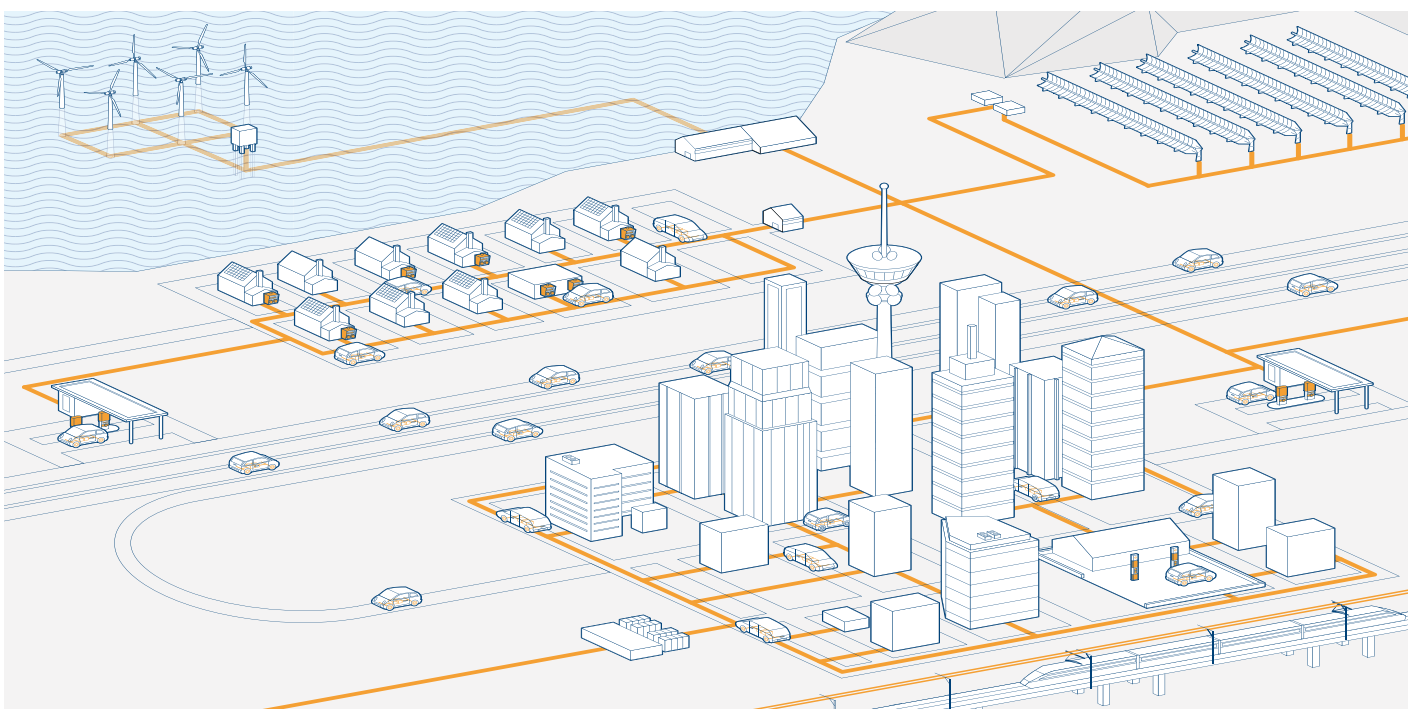

# Taking solar power into the future

## Smart grids and energy-efficient solutions

The global demand for electricity is growing faster than any other form of energy. At the same time, the generation of electric power is one of the largest single sources of carbon dioxide emissions.

Part of the answer to this problem lies in the generation and integration of renewable energy like solar power. ABB is at the forefront of this development – in smart grids, energy efficient homes, and the transmission over long-distances of renewable energy.

Many of the technologies that are making this possible were pioneered by ABB.

### Smart grids – the electrical system of the future

The smart grid of the future will have to meet four requirements: it will have to increase capacity, improve reliability, be more energy efficient, and integrate low carbon energy sources into the system.

Many of the technologies needed for the future electrical system are already well established, but need to be more widely applied. ABB, with its broad portfolio of power and automation products and systems, has pioneered many of these technologies and is already involved in numerous smart grid projects all over the world.

For instance, an award-winning ABB solution is helping Oncor, a leading U.S. power company to secure grid reliability in Dallas-Fort Worth, one of the country's largest metropolitan areas. The solution integrates large but unpredictable volumes of wind power into the Texas grid, reacts and heals grid disturbances in only 20 milliseconds, and saves almost one million megawatt-hours of energy and associated CO<sub>2</sub> emissions a year.

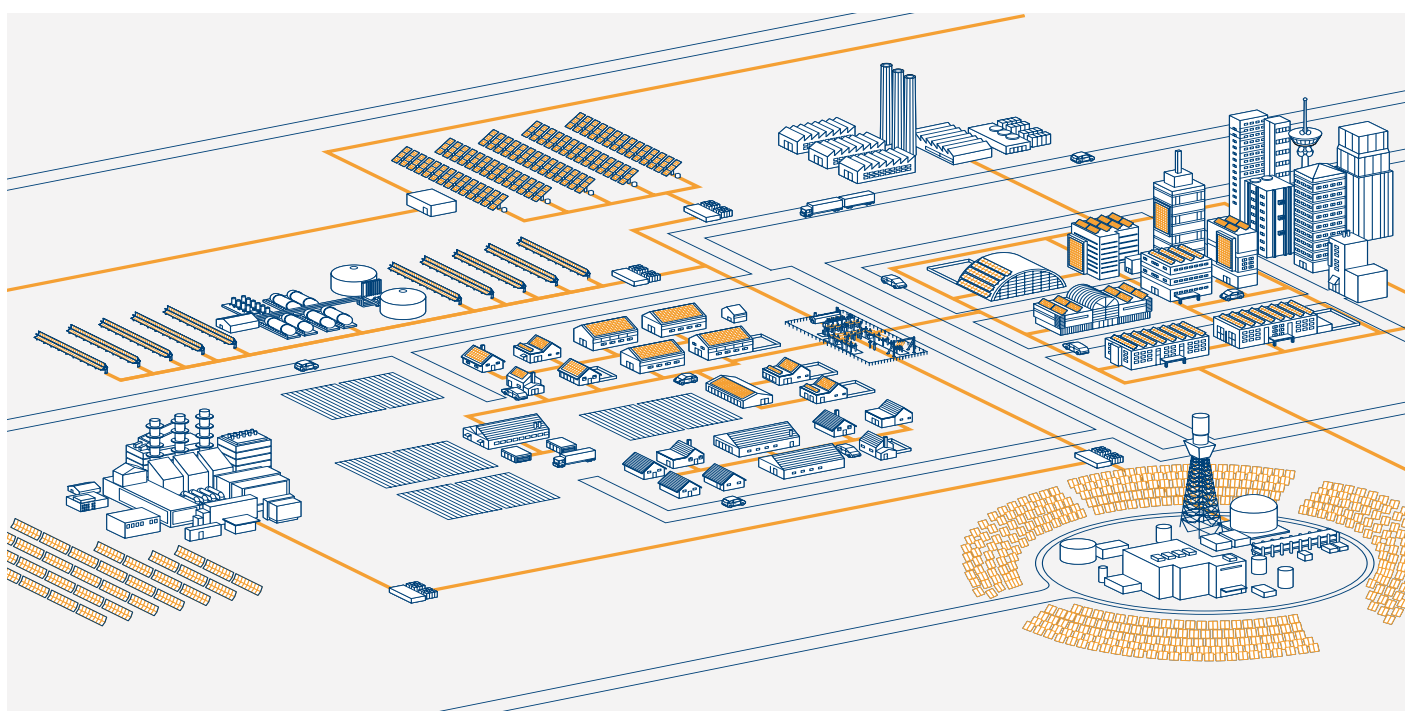

# Contact us

## ABB Automation Products GmbH

Wallstadter Str. 59  
D-68526 Ladenburg  
Tel: +49 62 21 701 1444  
Fax: +49 62 21 701 1382  
E-Mail: [plc.sales@de.abb.com](mailto:plc.sales@de.abb.com)

[www.abb.com/plc](http://www.abb.com/plc)

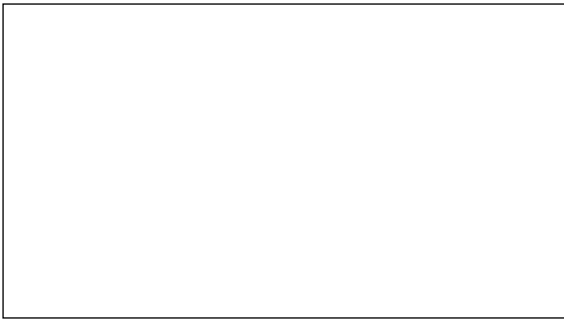

Scan the QR code  
and access:



PLC Website



CP600 brochure



PS501 Control  
Builder Plus brochure



Water brochure

### Note

We reserve the right to make technical changes or modify the contents of this document without prior notice.  
ABB does not accept any responsibility whatsoever for potential errors or possible lack of information in this document.

We reserve all rights in this document and in the subject matter and illustrations contained therein. Any reproduction, disclosure to third parties or utilization of its contents – in whole or in parts – is forbidden without prior written consent of ABB.

Copyright© 2013 ABB - All rights reserved