

# ABB Softstarters

The new PSS line  
from 3A to 515A

AC 1061



# ABB Softstarters

– the easy solution that will save you time and money

*Starting a motor across the line or through a wye-delta starter can result in rough and jerky starts. Across the line starts create a high starting current and torque. Wye-delta starts create high current and torque peaks when switching from the wye to delta connection.*

## Problem

High starting torque and torque peaks will reduce the life of mechanical devices such as gearboxes, belts, chains, couplings and bearings over time. This leads to high maintenance costs, frequent stoppages and unnecessary down time. It can also create direct operational problems when starting and stopping pumps due to water hammer in pipe systems and can damage goods when starting and stopping conveyor belts.

High starting currents and current peaks result in voltage drops on the network that can cause severe overall operational problems.

## ABB Solution

The best solution is to install an ABB Softstarter, Type PSS. The PSS offers smooth and controlled starts and stops which will save both time and money.



Fig. 1



Fig. 2



Fig. 3

## Typical applications for Type PSS softstarters:

- Elevators ..... Fig. 1
- Conveyor Belts ..... Fig. 2
- Fans ..... Fig. 3
- Pumps ..... Fig. 4

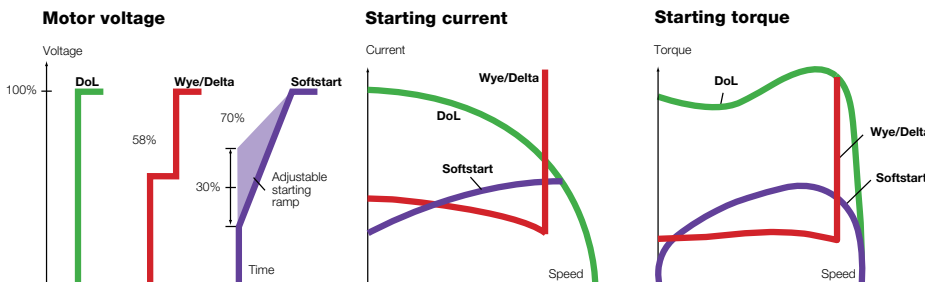
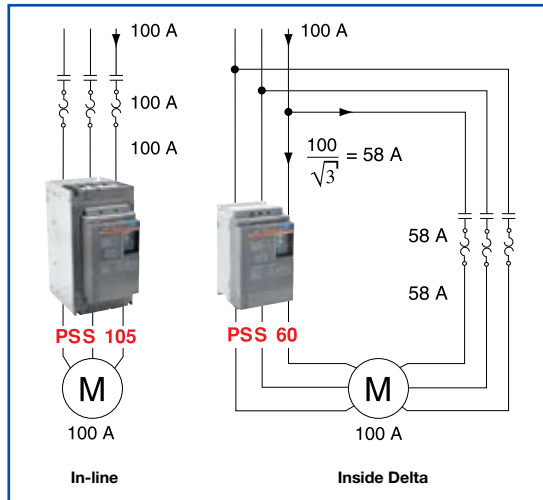

Fig. 4

# The new PSS line

- Inside delta connection
- Safe and robust design
- Flexible and compact solution
- Total solid state solution
- Solution for 690 V



These units can be used both for in-line or inside delta configuration. The latter gives a compact and flexible alternative to wye-delta starters. The inside delta configuration reduces costs since the current is only 58% of the rated motor current.

The new PSS line covers rated motor currents from 3A up to 515A with voltages between 208V and 690V. The complete PSS range is very compact and extremely easy to install and set up.

## The flexible line for 18A up to 515A: PSS18/30 to PSS300/515



These softstarters provide a flexible solution. When installed in-line with the motor, these softstarters cover up to 200Hp. The unit can also be wired inside the motor-delta, like a wye-delta starter, covering motors up to 350Hp. This flexibility makes it easier than ever

before to replace wye-delta

starters.

The total solid state solution — e.g., no moving contacts in the main circuit — is an attractive solution for applications with many starts per hour, such as elevators. Adjustable parameters include ramp time for start, ramp time for stop and initial voltage. These adjustable parameters allow the softstarter to be used for nearly all applications.

All of these units will reduce the current during start. However, occasionally a maximum starting current is desired. The PSS contains inputs for an optional current transformer. This function allows a maximum starting current setting that is independent of starting time.

The units are provided with four LEDs for *Power On*, *Top of ramp*, *External fault* and *General fault*. In addition, each unit has a built-in signal relay for faults. The LED and fault relay make it easy to check the status and simplify service.

Sometimes a motor is used above its own rated current, e.g. under well-cooled conditions. This is not a problem for these starters. The PSS18/30 through PSS300/515 are able to handle 15% over current continuously (service factor of 115% ).

The built-in signal contact can either be used for bypassing the unit or for sequential starting of several motors.



A typical "Inside Delta" combination as a replacement for a Y/D-starter

## The compact line for 3A up to 25A: PSS03 to PSS25

This is a very compact solution for starting up small motors with rated current from 3A to 25A. It is suitable for 230V, 380V, 480V and 600V and is designed for DIN rail mounting.



The built-in by-pass contacts allow space saving, compact systems to be built.

Adjustable parameters include ramp time for start, ramp time for stop and initial voltage. These units cover a control voltage range of 24VAC/DC through 110VAC/VDC and 110VAC through 480VAC.

# ABB Softstarters

PSS03 – PSS 142/245



	PSS03 – PSS25			PSS18/30 – PSS142/245		
In-line, 480V	2Hp	7.5Hp	20Hp	10Hp	20Hp	25Hp
Inside Delta, 480V	–	–	–	20Hp	30Hp	40Hp
Type	<b>PSS03</b>	<b>PSS12</b>	<b>PSS25</b>	<b>PSS18/30</b>	<b>PSS30/52</b>	<b>PSS37/64</b>
Catalog number 230V	PSS03-220B	PSS12-220B	PSS25-220B	PSS18/30-500	PSS30/52-500	PSS37/64-500
380V <sup>①</sup>	PSS03-400B	PSS12-400B	PSS25-400B	PSS18/30-500	PSS30/52-500	PSS37/64-500
480V	PSS03-480B	PSS12-480B	PSS25-480B	PSS18/30-500	PSS30/52-500	PSS37/64-500
600V	–	PSS12-600B	PSS25-600B	PSS18/30-690	PSS30/52-690	PSS37/64-690
UL Rated current A <sup>①</sup>	3.4	11	27	18	28	34

## Isolation/bypass contactor (In-line) <sup>①</sup>

Type	A9	A12	A26	A16	A30	A40
------	----	-----	-----	-----	-----	-----

## Thermal overload relay (In-line) <sup>①</sup>

Type	TA25DU	TA25DU	TA25DU	TA25DU	TA25DU	TA42DU
------	--------	--------	--------	--------	--------	--------

## Bypass contactor (Inside Delta) <sup>①</sup>

Type	–	–	–	A16	A30	A40
------	---	---	---	-----	-----	-----

## Thermal overload relay (Inside Delta) <sup>①</sup>

Type	–	–	–	TA25DU	TA25DU	TA25DU
------	---	---	---	--------	--------	--------

## Current transformers

Type	–	–	–	PSCT60 2 turns	PSCT40 1 turn	PSCT50 1 turn
------	---	---	---	----------------	---------------	---------------

## Control voltage

Type	24 – 110VAC/VDC	24 – 110VAC/VDC	24 – 110VAC/VDC	120V or 240VAC	120V or 240VAC	120V or 240VAC
	110 – 480VAC	110 – 480VAC	110 – 480VAC			

<sup>①</sup> Contact ABB for IEC ratings.



ABB Softstarters Type PSS18/30 – PSS300/515 are available in two versions: Code F for supply voltage 110 – 120V 50/60 Hz; Code L for 220 – 240 V 50/60 Hz. Example: 50Hp motor, connected in-line, 480V network and supply voltage 230V 60Hz – use order code: PSS72/124-500L.



30Hp 50Hp	30Hp 60Hp	40Hp 75Hp	50Hp 75Hp	60Hp 100Hp	75Hp 150Hp	100Hp 150Hp
<b>PSS44/76</b>	<b>PSS50/85</b>	<b>PSS60/105</b>	<b>PSS72/124</b>	<b>PSS85/147</b>	<b>PSS105/181</b>	<b>PSS142/245</b>
PSS44/76-500	PSS50/85-500	PSS60/105-500	PSS72/124-500	PSS85/147-500	PSS105/181-500	PSS142/245-500
PSS44/76-500	PSS50/85-500	PSS60/105-500	PSS72/124-500	PSS85/147-500	PSS105/181-500	PSS142/245-500
PSS44/76-500	PSS50/85-500	PSS60/105-500	PSS72/124-500	PSS85/147-500	PSS105/181-500	PSS142/245-500
PSS44/76-690	PSS50/85-690	PSS60/105-690	PSS72/124-690	PSS85/147-690	PSS105/181-690	PSS142/245-690
40	47	56	67	85	105	125
A50	A50	A63	A75	A95	A110	A145
TA42DU	TA75DU	TA75DU	TA75DU	TA110DU	TA110DU	TA200DU
A40	A50	A63	A63	A75	A110	A110
TA42DU	TA75DU	TA75DU	TA75DU	TA75DU	TA110DU	TA110DU
PSCT60 1 turn	PSCT75 1 turn	PSCT75 1 turn	PSCT100 1 turn	PSCT125 1 turn	PSCT150 1 turn	PSCT200 1 turn
120V or 240VAC	120V or 240VAC	120V or 240VAC	120V or 240VAC	120V or 240VAC	120V or 240VAC	120V or 240VAC



# ABB Softstarters

PSS175/300 – PSS300/515



PSS175/300 – PSS300/515			
In-line, 480V	125Hp	150Hp	200Hp
Inside Delta, 480V	200Hp	300Hp	350Hp
Type	<b>PSS175/300</b>	<b>PSS250/430</b>	<b>PSS300/515</b>
Catalog number 230V	PSS175/300-500	PSS250/430-500	PSS300/515-500
380V <sup>①</sup>	PSS175/300-500	PSS250/430-500	PSS300/515-500
480V	PSS175/300-500	PSS250/430-500	PSS300/515-500
600V	PSS175/300-690	PSS250/430-690	PSS300/515-690
UL Rated current A	156	225	248

## Line contactor <sup>①</sup>

Type	A185	A210	A260
------	------	------	------

## Thermal overload relay <sup>①</sup>

Type	TA200DU	TA450DU	TA450DU
------	---------	---------	---------

## Bypass contactor (Inside Delta) <sup>①</sup>

Type	A145	A210	A260
------	------	------	------

## Thermal overload relay (Inside Delta) <sup>①</sup>

Type	TA200DU	TA450DU	TA450DU
------	---------	---------	---------

## Current transformers

Type	PSCT250 1 turn	PSCT400 1 turn	PSCT400 1 turn
------	----------------	----------------	----------------

## Control voltage

Type	120V or 240VAC	120V or 240VAC	120V or 240VAC
------	----------------	----------------	----------------

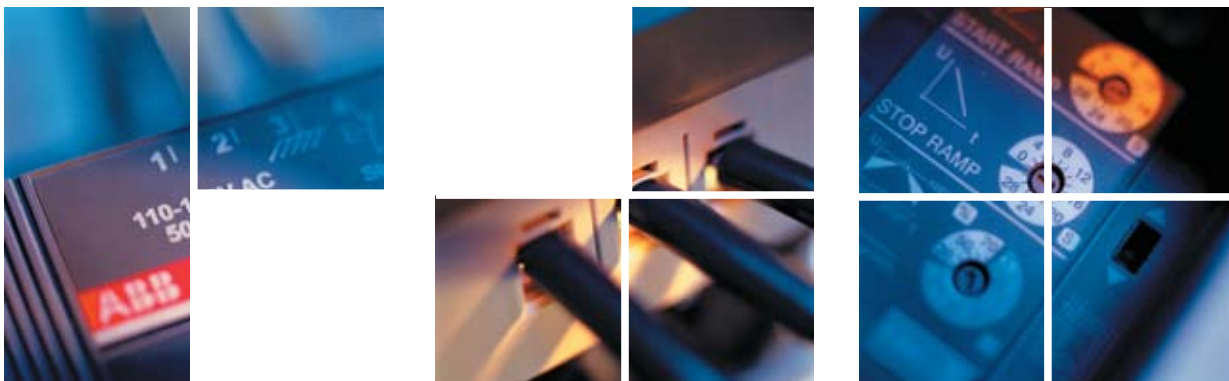

# ABB Softstarters

The complete range



ABB low voltage softstarters now cover motor amperages from 3A to 1250A up to 600VAC. The new PSS softstarter line brings a reputation of long life and reliability in a flexible and compact form for smaller motors.

## Range of ABB low voltage softstarters

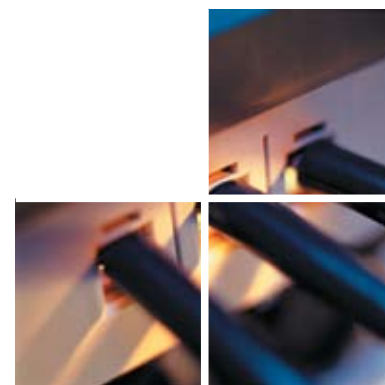
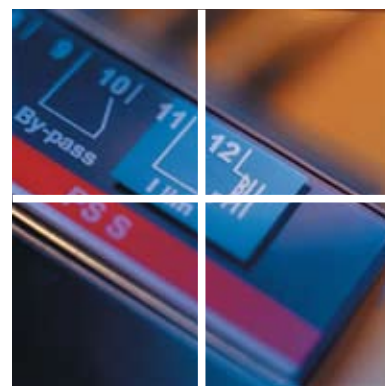
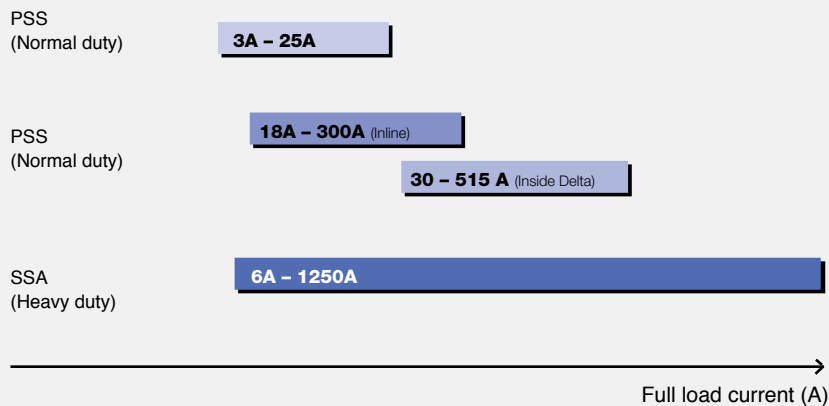



Low Voltage Products & Systems

ABB Inc.  
1206 Hatton Road  
Wichita Falls, TX 76302  
Tel. 888-385-1221  
940-397-7000  
Fax 940-397-7085  
Web [www.abb-control.com](http://www.abb-control.com)

AC 1061  
March, 2001