

Softstart

**Changing of
thyristor modules
PSS18...300
PST30...300**

5309 705-1 RevD Sep-08



ABB

Check List for changing Thyristor modules.

Please note!

The life span of electronics can be affected by damage caused by electrostatic discharge. This can happen if a component is touched by a charged tool or person. Therefore it is very important that all tools and personnel are discharged by touching an earthed point before the printed circuit board or any of the components are touched. It is equally important to discharge the package with the new component before opening it.

A person walking on a carpet is able to be charged with up to fifteen thousand volt (15000V). Compare this with the fact that some sensitive components can be destroyed when discharged on a much lower level (about 100V). We kindly ask you to pay notice to this as this is a vital point in order to ensure the life span of the product.

Tools

	PSS18...72	PST30...72	PSS85...142 PST85...142	PSS175...300 PST175...300
Cover	Screwdriver	Torx T15	Torx T20	Torx T20
Thyristor mounting.	Torx T25	Torx T25	Torx T25	Torx T25
Thyristor terminal connection.	Pozidrive	Pozidrive	Pozidrive Hexagon key 13	Hexagon key 13 Hexagon key 16

Handling

Modules and heat sinks are to be handled carefully to avoid scratches and other marks.

Avoid touching the contact surfaces.

Step by step.

- ◆ Disconnect the voltage from terminals 1L1, 3L2, and 5L3 (main supply).
- ◆ Disconnect all cable from the terminals.
- ◆ Remove the front cover.
- ◆ Discharge the tools and yourself by touching earth.
- ◆ Disconnect the electrical connection on the thyristors.
- ◆ Disconnect the thyristors.
- ◆ Clean the contact surface on the heat sink and modules with Ethanol.
Use lint-free cloth (paper or linen cloth)
- ◆ A very thin layer of heat transfer compound shall be put on the contact surfaces of the modules with a lint-free cloth.
Too much compound between module and heat sink will give bad thermal conduction and cause risk of overheating the thyristors.
- ◆ Mount the new thyristors (Use the torque in the table).
- ◆ Mount the electrical connection on the thyristors.
- ◆ Mount the front cover.
- ◆ Connect the voltage and the other cable.

Ready for start!!

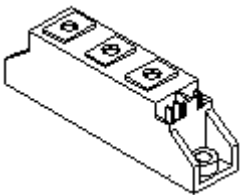

Picture 1

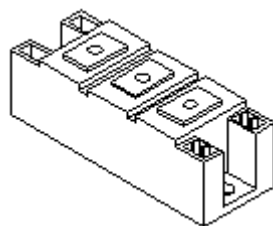

Picture 2

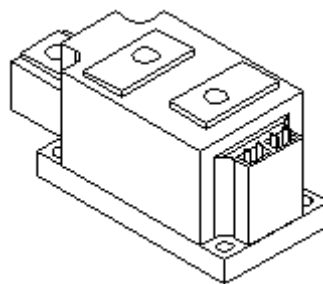

Picture 3

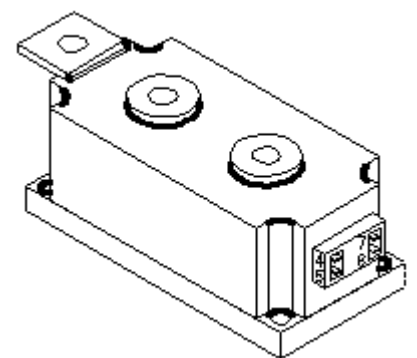

Picture 4

Thyristor		Mounting torque	Terminal connection torque	Picture
Semikron	IXYS			
SKKT27...SKKT92	MCC26...MCC95	3,0 Nm	3,0 Nm	1
SKKT132...SKKT172	MCC132...MCC162	3,0 Nm	5,0 Nm	2
SKKT210...SKKT330	MCC225...MCC312	3,0 Nm	9,0 Nm	3

SKKT500	MCC500		3,0Nm	12,0 Nm	4
---------	--------	--	-------	---------	---

PS S18...50

PS T30...50

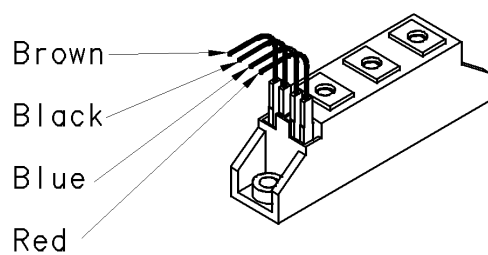

PS S60...85

PS T60...85

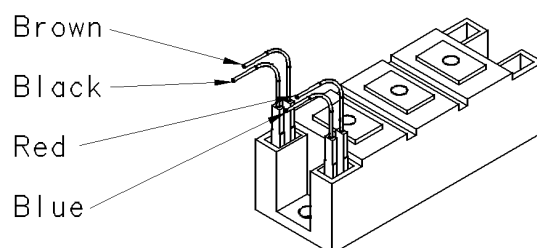

PS S105...175

PS T105...210

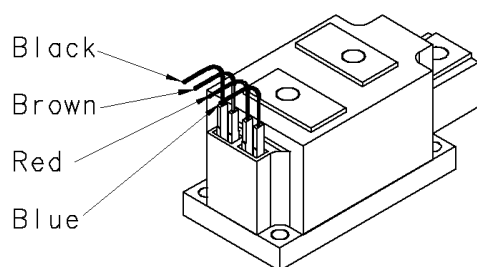

PS S250...300

PS T250...300

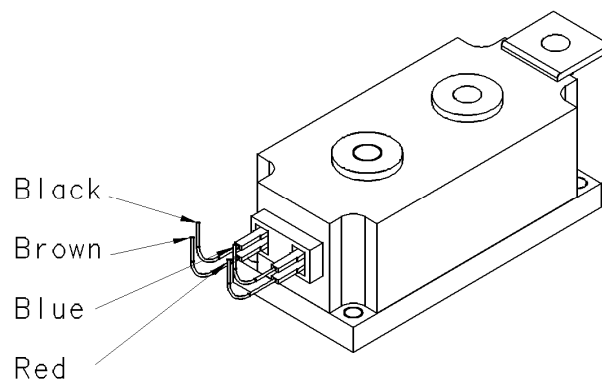

ABB

ABB AB, Control

S-721 61 Västerås, SWEDEN

Telephone +46 21 32 07 00

TELEFAX +46 21 12 60 01

