

## Micro drives

ACS255 600 V AC, 1 to 20 hp



Compact and available with flexible mounting options without the need for accessory mounting kits. These drives are ideal for panel builders and OEM's needing a micro drive with low cost, flexible mounting options, and rapid parameter setup.

ABB micro drive ACS255 with 600 V AC supply offers easy to use and compact solutions for general purpose low power applications, such as; screws, mixers, pumps, fans and conveyors. The key features include a built-in safe torque-off (STO), Modbus RTU and CANopen communication interfaces.

### Part of ABB micro drives portfolio

The ACS255 drive is part of ABB's complete micro drive range, which offers a solution for every need:

- Drives for simple to more complex machines
- Full voltage range from 110 to 600 V
- Enclosures IP20 and IP66
- Power range up to 20 hp

### Supporting options

- Remote keypad (RCRP-02) provides easy cabinet installations
- Parameter upload/download tool (RCCS-01) for straightforward commissioning
- Relay output card (RCRO-01)
- UL Type 4X/IP66 frames for harsh environments up to 15 hp
- Disconnect switch for UL Type 4X/IP66 frames

### Product highlights

- Easy to use, compact design
- High performance vector control
- Input voltage 500 to 600 V +/- 10%
- Built-in safe torque-off (STO) complies with EN62061 SIL level 2
- Built-in braking chopper in all types
- Built-in communication with Modbus RTU and CANopen® interfaces
- Rated for 150% overload for 60 sec as standard
- DIN rail mounting
- Pluggable control terminals
- Remote keypad available as an option
- PID control with sleep mode
- IP20 panel mount and IP66/NEMA 4X enclosures
- Feed-thru wiring on IP 20 drives
- Front mounted operator control option for IP66/ NEMA 4X drives

Output ratings		Type designation	Frame size	Height	Width	Depth	Weight
$P_{N,HD}$ hp	$P_{N,HD}$ kW	$I_{2N}$ A		in	in	in	kg
<b>3-phase AC supply, 500 to 600 V</b>							
1	0.75	2.1	ACS255-03U-02A1-6	P2	8.70	4.41	7.28 4
2	1.5	3.1	ACS255-03U-03A1-6	P2	8.70	4.41	7.28 4
3	2.2	4.1	ACS255-03U-04A1-6	P2	8.70	4.41	7.28 4
5	4	6.5	ACS255-03U-06A5-6	P2	8.70	4.41	7.28 4
7.5	5.5	9	ACS255-03U-09A0-6	P2	8.70	4.41	7.28 4
10	7.5	12	ACS255-03U-12A0-6	P3	10.28	5.16	8.07 7.7
15	11	17	ACS255-03U-17A0-6	P3	10.28	5.16	8.07 7.7
20	15	22	ACS255-03U-22A0-6	P3	10.28	5.16	8.07 7.7
1	0.75	2.1	ACS255-03U-02A1-6+B063(+F278)	P2	10.12	7.40	9.41 10.6
2	1.5	3.1	ACS255-03U-03A1-6+B063(+F278)	P2	10.12	7.40	9.41 10.6
3	2.2	4.1	ACS255-03U-04A1-6+B063(+F278)	P2	10.12	7.40	9.41 10.6
5	4	6.5	ACS255-03U-06A5-6+B063(+F278)	P2	10.12	7.40	9.41 10.6
7.5	5.5	9	ACS255-03U-09A0-6+B063(+F278)	P2	10.12	7.40	9.41 10.6
10	7.5	12	ACS255-03U-12A0-6+B063(+F278)	P3	12.20	8.29	9.88 16.1
15	11	17	ACS255-03U-17A0-6+B063(+F278)	P3	12.20	8.29	9.88 16.1

$P_N$  for kW = Typical motor power at 400V in normal use  
 $P_N$  for Hp = Typical motor power at 480V in normal use  
 $I_{2N}$  for A = Continuous rms current. 50% overload is allowed for one minute in ten minutes  
U within the type code = no EMC filter  
+B063 = IP66/UL TYPE 4X enclosure without input disconnect.  
+B063+F278 = IP66/UL TYPE 4X enclosure with input disconnect and operator controls.

### Standard I/O configurations

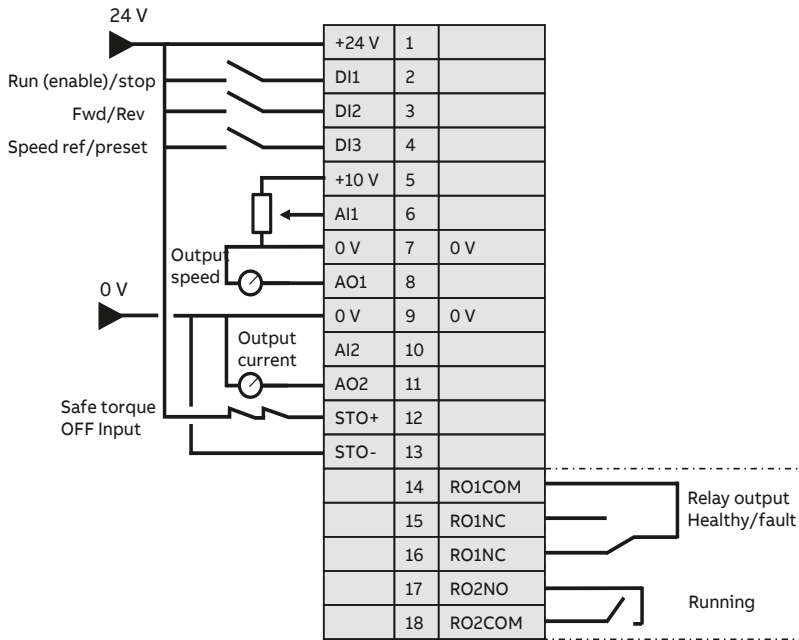

ABB Inc.  
Robotics and Motion  
Drives and Controls  
16250 W. Glendale Drive  
New Berlin, WI 53151

Mains connection	
Supply voltage	3-ph, 500 to 600 V ±10%: 1 to 20 hp
Frequency	48 to 62 Hz
Phase imbalance	3% maximum allowed
Motor connection	
Motor types	Asynchronous induction motors Permanent magnet synchronous motors
Frequency	0 to 500 Hz, 0.1 Hz resolution
Overload capacity	150% of rated amps for 1 minute
Switching frequency	4-32kHz Effective
Control types	Scalar U/f Sensorless vector speed control PM motor vector speed control BLDC motor speed control (contact factory)
Environmental limits	
Temperature	Storage: -40 to 60°C Operating: -10 to 50°C
Relative humidity	95% (without condensation)
Vibration	Conforms to IEC 60068-2-6 Sinusoidal Vibration 10 - 57Hz @ 0.075mm Pk 57 - 150Hz @ 1g Pk
Product compliance	
UL, cUL, C-Tick, CE listing/conformance; RoHS Compliant	
Programmable control connections	
Power supply	24 Volt DC, 100mA, Short Circuit Protected 10 Volt DC, 5mA for Potentiometer
Programmable Inputs	5 Total 3 Digital 2 Analog / Digital selectable
Digital inputs	8 - 30 Volt DC, internal or external supply Response time < 4ms
Analog inputs	0 - 10 VDC, 0 or 4 - 20mA, bi-polar Resolution: 12 bits Response time: < 4ms Accuracy: < 1% full scale Parameter adjustable scaling and offset
Programmable outputs	4 Total 2 Analog / Digital 2 Relay
Relay output	Maximum Voltage: 250 VAC, 30 VDC Switching Current Capacity: 6A AC, 5A DC
Analog outputs	0 to 10 Volt 0 to 20mA 4 to 20mA
PI control	Internal PID Controller Multi Setpoint Select Standby / Sleep Mode Boost Function
Serial communication	Modbus RTU 9.6 - 115.2 kbps selectable 8N1, 8N2, 8E1, 8O1 CANopen 125 - 1000kbps