

ACS800

Dimensional Drawings ACS800-07 Drives (45 to 560 kW) ACS800-U7 Drives (50 to 600 HP)

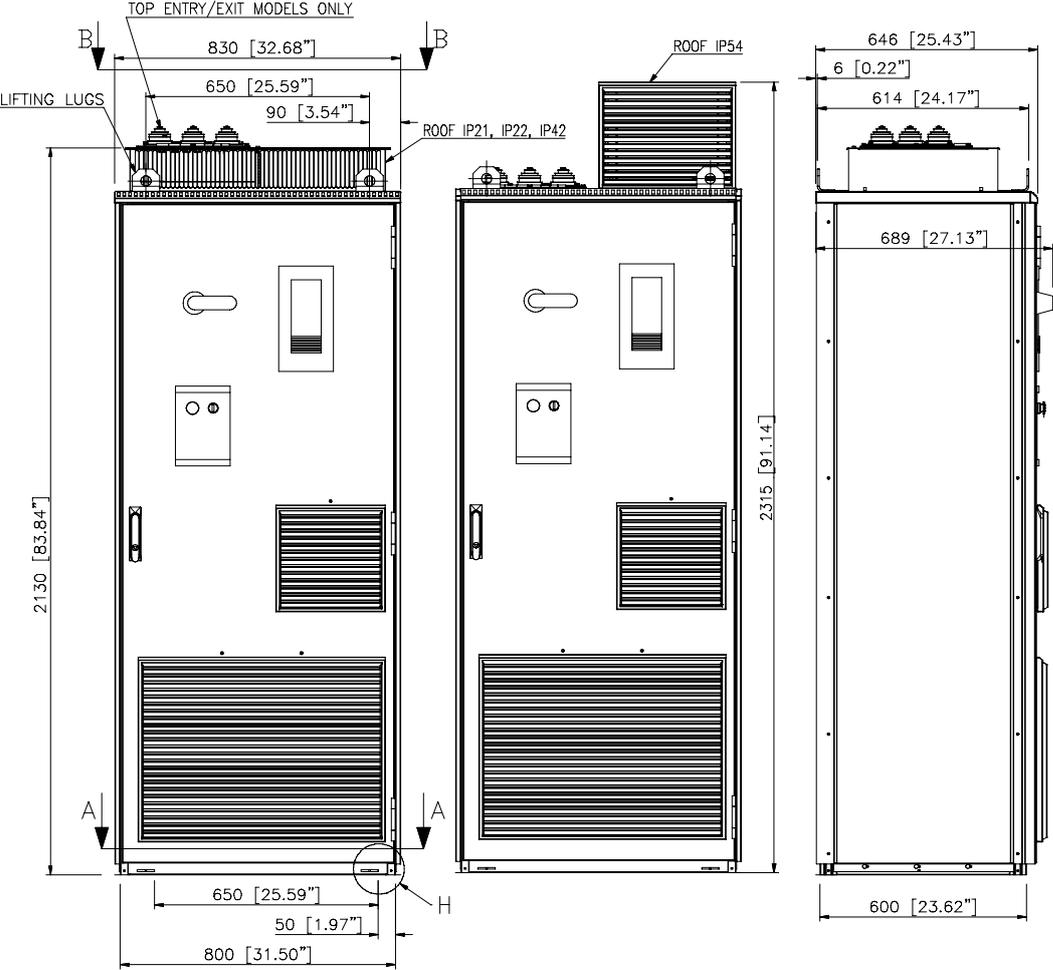

ACS800 Single Drive Manuals

HARDWARE MANUALS (appropriate manual is included in the delivery)

ACS800-01/U1 Hardware Manual 0.55 to 110 kW (0.75 to 150 HP)
3AFE 64382101 (English)

ACS800-01/U1 Marine Supplement 3AFE 64291275 (English)

ACS800-02/U2 Hardware Manual 90 to 500 kW (125 to 600 HP)
3AFE 64567373 (English)

ACS800-04/04M/U4 Hardware Manual 90 to 500 kW (125 to 600 HP)
3AFE 64671006 (English)

ACS800-07/U7 Hardware Manual 45 to 560 kW (50 to 600 HP)
3AFE 64702165 (English)

ACS800-07/U7 Dimensional Drawings 45 to 560 kW (50 to 600 HP)
3AFE 64775421

ACS800-07 Hardware Manual 500 to 2800 kW
3AFE 64731165 (English)

ACS800-17 Hardware Manual 75 to 1120 kW
3AFE 64681338 (English)

- Safety instructions
- Electrical installation planning
- Mechanical and electrical installation
- Motor control and I/O board (RMIO)
- Maintenance
- Technical data
- Dimensional drawings
- Resistor braking

FIRMWARE MANUALS, SUPPLEMENTS AND GUIDES

(appropriate documents are included in the delivery)

Standard Application Program Firmware Manual
3AFE 64527592 (English)

System Application Program Firmware Manual
3AFE 63700177 (English)

Application Program Template Firmware Manual
3AFE 64616340 (English)

Master/Follower 3AFE 64590430 (English)

PFC Application Program Firmware Manual
3AFE 64649337 (English)

Extruder Control Program Supplement 3AFE 64648543 (English)

Centrifuge Control Program Supplement
3AFE 64667246 (English)

Traverse Control Program Supplement 3AFE 64618334 (English)

Crane Control Program Firmware Manual 3BSE 11179 (English)

Adaptive Programming Application Guide
3AFE 64527274 (English)

OPTION MANUALS (delivered with optional equipment)

Fieldbus Adapters, I/O Extension Modules etc.

Table of contents

ACS800 Single Drive Manuals

Table of contents

Dimensional drawings

Frame size R6

Types ACS800-07-0070/0100/0120/130-3, -0100/0120/0140/150-5, -0070/0100/0120-7 . . .	6
Units with brake resistors (+D151)	7
Cable connection terminals (R6)	8

Frame sizes R7 and R8

IP21, IP22 and IP42 units with bottom entry/exit and IP21 units with top entry/exit	10
IP22 and IP42 units with top entry and bottom exit, bottom entry and top exit or top entry and exit	11
IP54 and IP54R units	12

Frame size R7

Units with EMC filter (+E202, IP21, IP22, IP42)	14
Units with EMC filter (+E202, IP54)	15
Units with brake resistors (+D151)	16
Cable connection terminals (R7)	17
Cable connection terminals of R7 units with du/dt filter (+E205)	18
Cable connection terminals of R7 units with brake resistors (+D151)	19
Cable connection terminals of R7 units with brake resistors (+D151) and du/dt filter (+E205)	20

Frame size R8

Units with EMC filter (+E202, IP21, IP22, IP42)	22
Units with EMC filter (+E202, IP54)	23
Types ACS800-07-0260/0320-3, -0320/0400/0440/0490-5, -0490/0550/0610-7 with brake resistors (+D151)	24
Types ACS800-07-0400/0440/0490-3, -0550/0610-5 with brake resistors (+D151)	25
Cable connection terminals (R8)	26
Cable connection terminals of R8 units with du/dt filter (+E205)	27
Cable connection terminals of types ACS800-07-0320/0400/0440-7 with brake resistors (+D151)	28

Cable connection terminals of types ACS800-07-0320/0400/0440-7 with brake resistors (+D151) and du/dt filter (+E205)	29
Cable connection terminals of types ACS800-07-0260/0320-3, -0320/0400//0440/0490-5, -0490/0550/0610-7 with brake resistors (+D151)	30
Cable connection terminals of types ACS800-07-0400/0440/0490-3, -0550/0610-5 with brake resistors (+D151)	31
Cable connection terminals of types ACS800-07-0260/-0320-3, -0320/-0400/0440/0490-5, -0490/0550/0610-7 with brake resistors (+D151) and du/dt filter (+E205)	32
Cable connection terminals of types ACS800-07-0400/0440/0490-3, -0550/0610-5 with brake resistors (+D151) and du/dt filter (+E205)	33

Fastening of marine cabinets (+C121)

Frame size R6	35
Frame size R6: various cabinet widths and combinations	36
Frame sizes R7 and R8	37
Frame sizes R7 and R8: various cabinet widths and combinations	38

Dimensional drawings (USA)

Frame size R6 (USA)	39
Types ACS800-U7-0100/0120/0140-5 and -0070/0100/0120-7	40
Frame sizes R7 and R8 (USA)	41
Frame size R7 with EMC filter (+E202, UL type 1)	42
Frame size R7 with EMC filter (+E202, UL type 12)	43
Frame size R8 with EMC filter (+E202, UL type 1)	44
Frame size R8 with EMC filter (+E202, UL type 12)	45

Dimensional drawings

The dimensions are given in millimetres and [inches] in the drawings below.

Frame size R6

Dimensional drawings of frame size R6 are shown below.

Types ACS800-07-0070/0100/0120/130-3, -0100/0120/0140/150-5, -0070/0100/0120-7

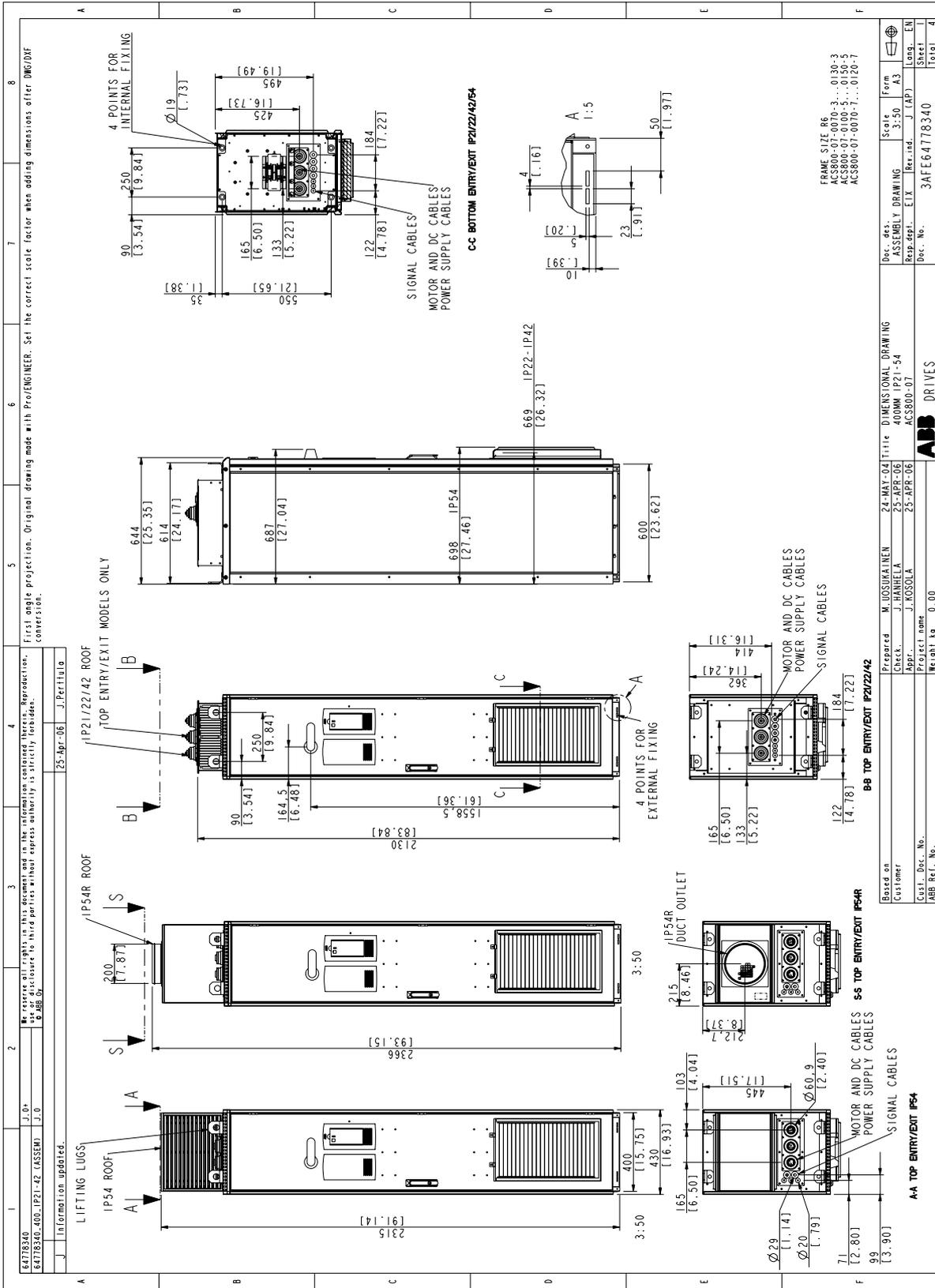

64778340_1/4 J

Frame sizes R7 and R8

The outer dimensions of the drive cabinet in frame sizes R7 and R8 are identical when no brake resistors or du/dt filter are included. The common dimensional drawings are shown below.

IP22 and IP42 units with top entry and bottom exit, bottom entry and top exit or top entry and exit

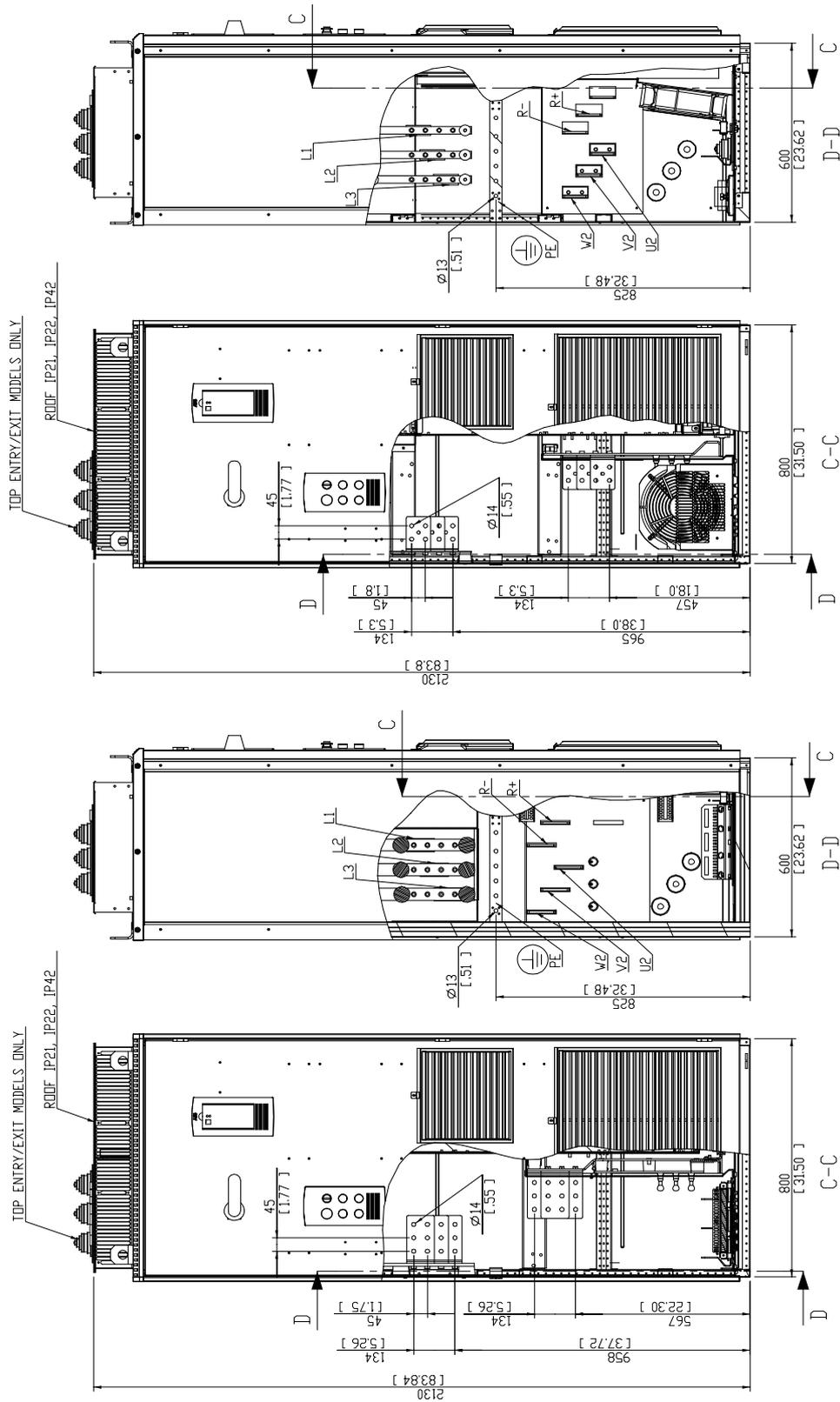

FRAME SIZE R7
 ACS800-07/U7-0140-3 ...
 -0210-3
 ACS800-07/U7-0170-5 ...
 -0260-5

FRAME SIZE RB
 ACS800-07/U7-0260-3 ... -0490-3
 ACS800-07/U7-0320-5 ... -0610-5
 ACS800-07/U7-0320-7 ... -0610-7



Frame size R7

Dimensional drawings of cable connection terminals and units with optional EMC filter, du/dt filter and brake resistors are shown below.

Units with EMC filter (+E202, IP21, IP22, IP42)

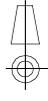
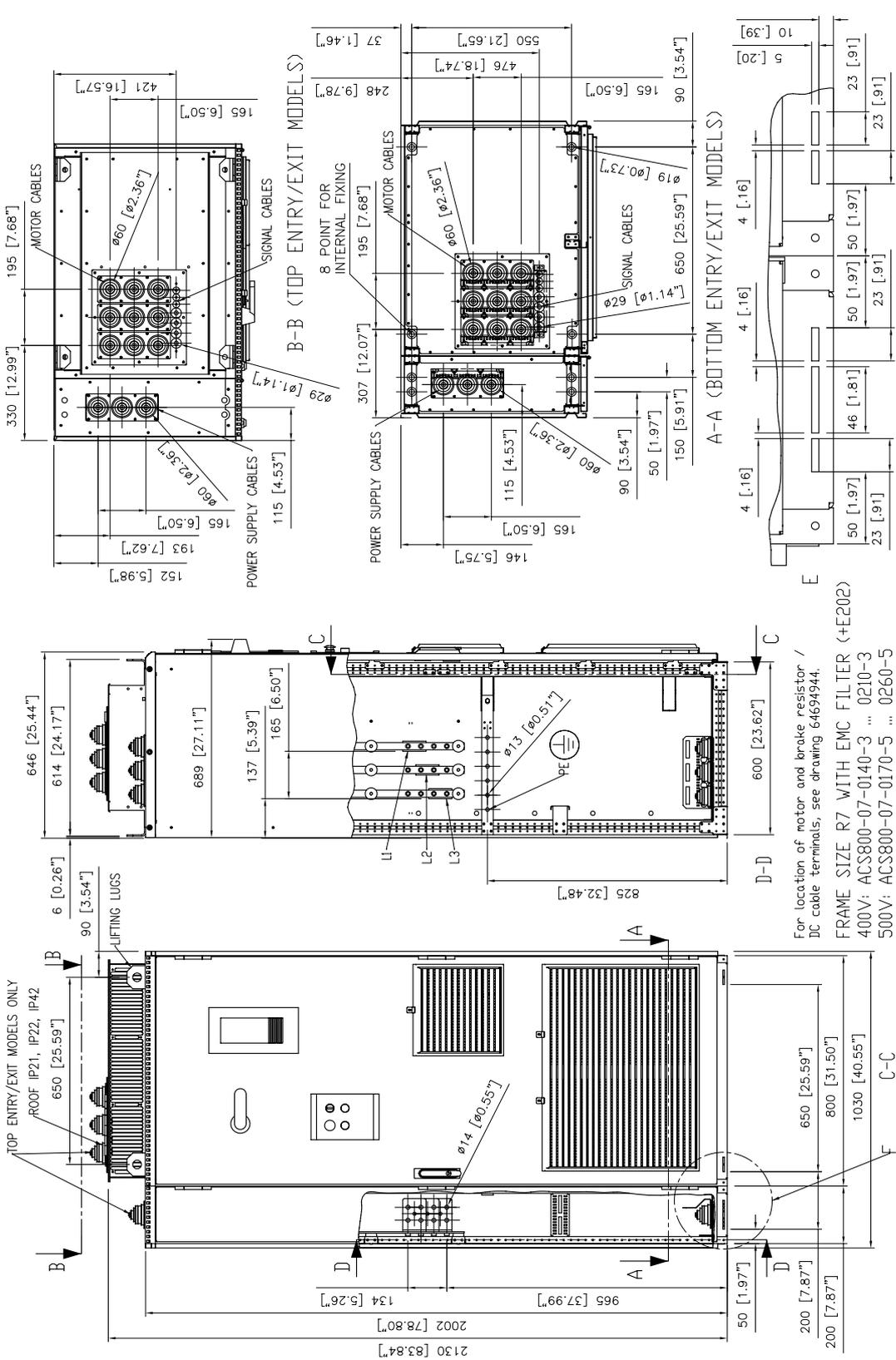

68407044_1/4 A

Units with EMC filter (+E202, IP54)

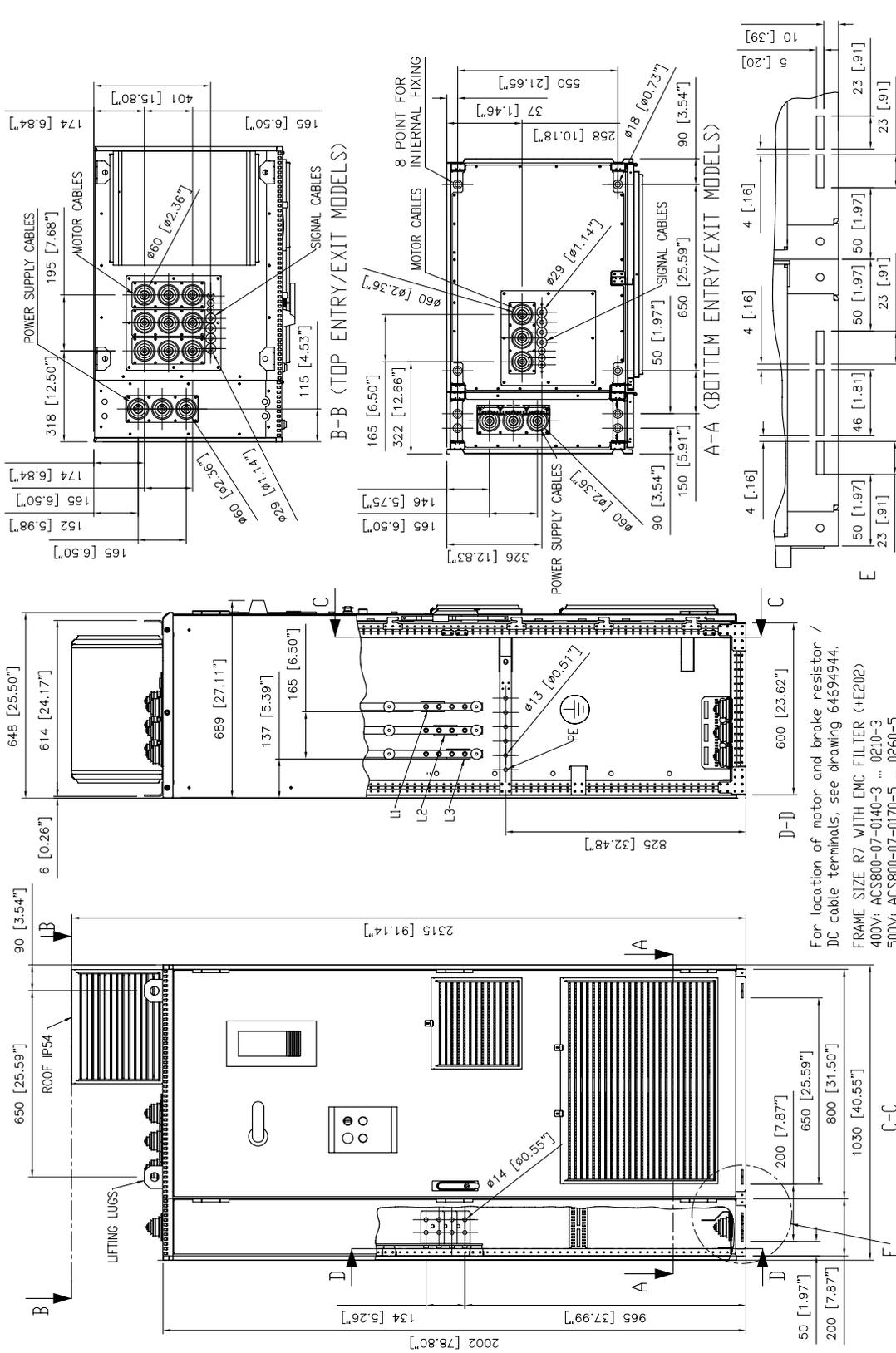

68407044_2/4 A

Cable connection terminals (R7)

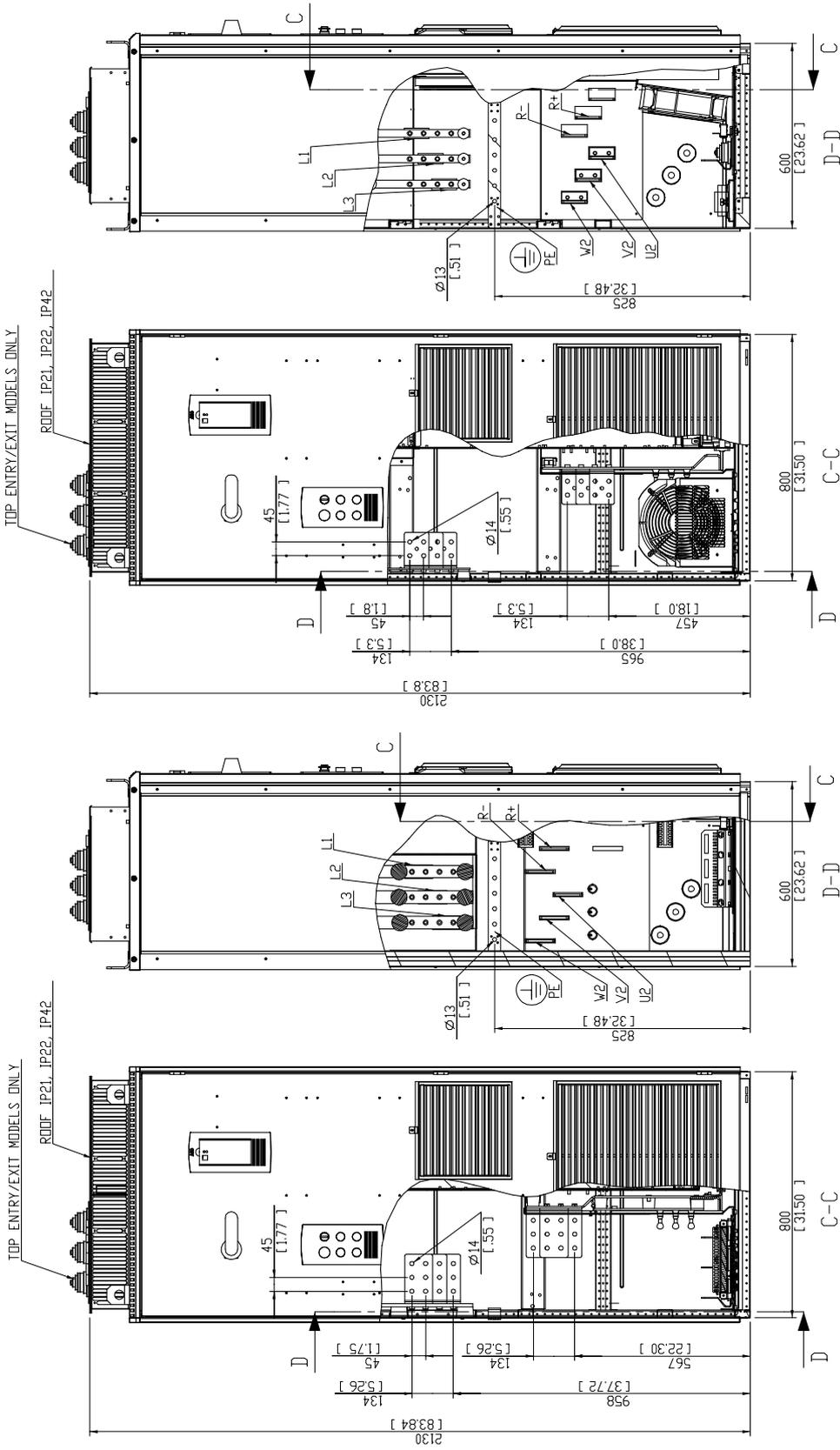

FRAME SIZE R7
 ACS800-07/U7-0140-3 ...
 -0210-3
 ACS800-07/U7-0170-5 ...
 -0260-5

FRAME SIZE RB
 ACS800-07/U7-0260-3 ... -0490-3
 ACS800-07/U7-0320-5 ... -0610-5
 ACS800-07/U7-0320-7 ... -0610-7



Cable connection terminals of R7 units with du/dt filter (+E205)

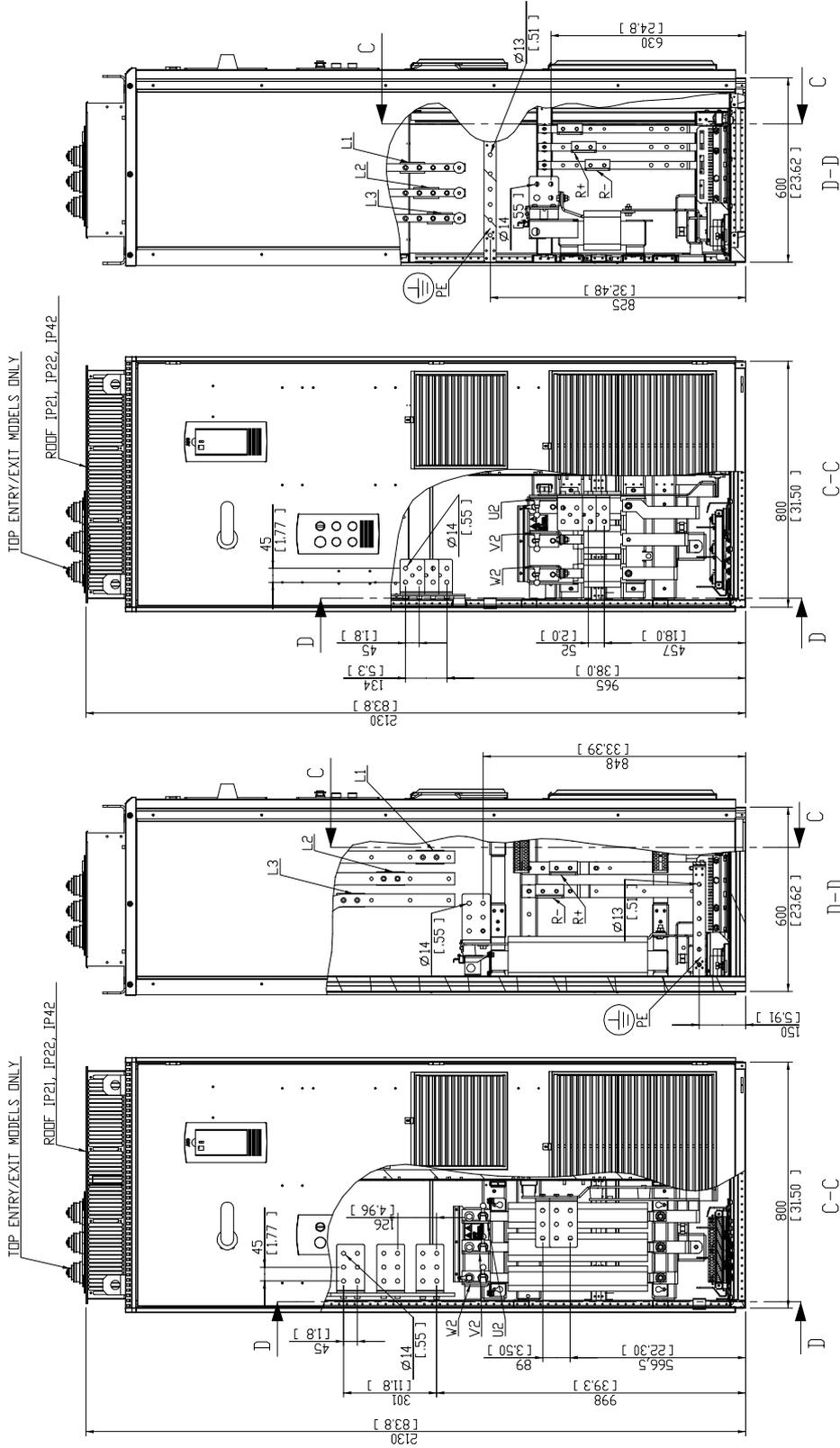

FRAME SIZE R7 WITH du/dt FILTER
 (+E205)
 ACS800-07/U7-0170-5 ... -0260-5
 ACS800-07/U7-0140-7 ... -0260-7

FRAME SIZE R8 WITH du/dt FILTER
 (+E205)
 ACS800-07/U7-0320-5 ... -0610-5
 ACS800-07/U7-0320-7 ... -0610-7

68749930 4/6

Cable connection terminals of R7 units with brake resistors (+D151)

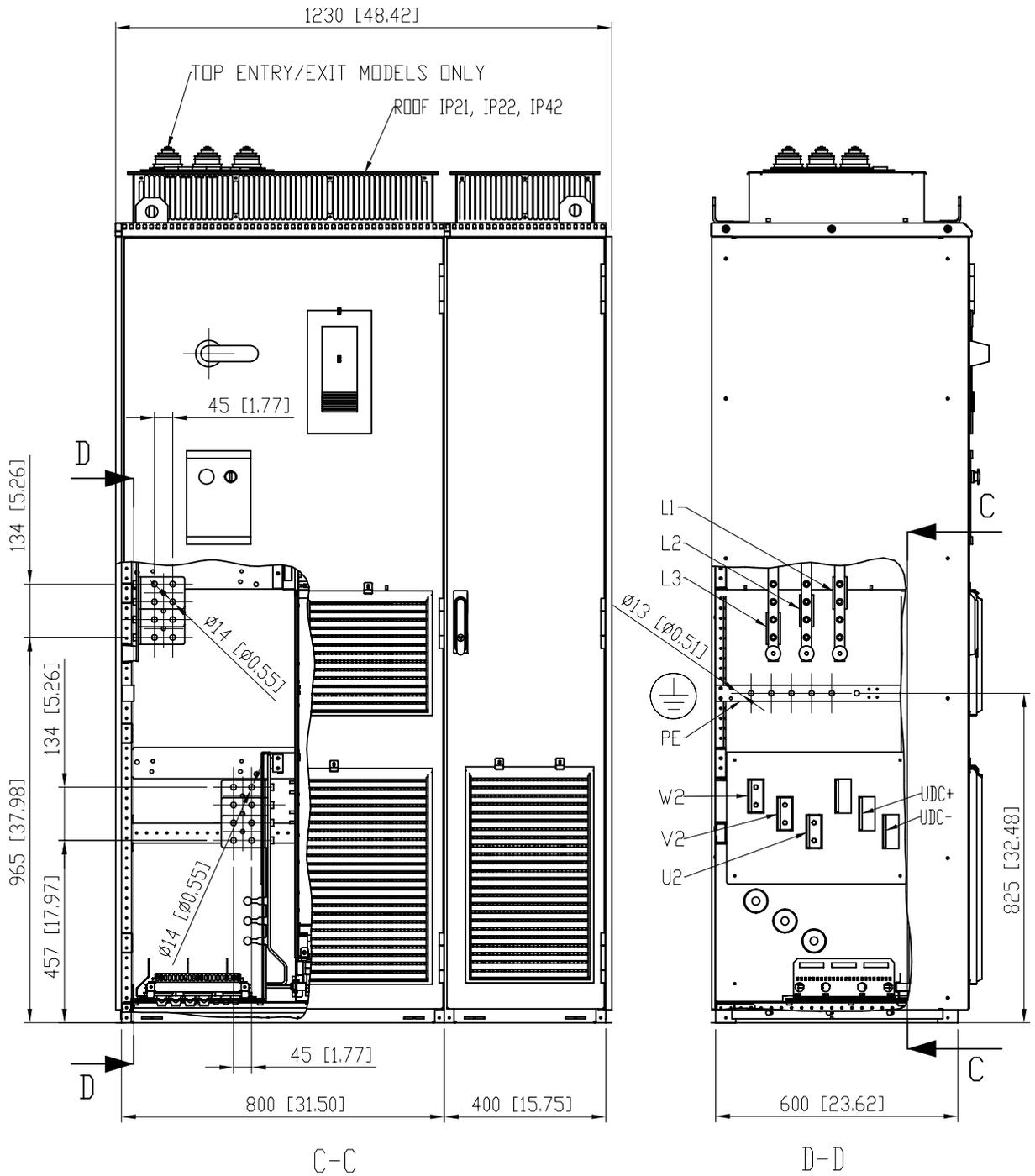

FRAME SIZE R7 WITH BRAKE RESISTOR
 1xSAFURxxx (+D151)
 400V: ACS800-07-0140/0170/0210-3
 500V: ACS800-07-0170/0210/0260-5
 690V: ACS800-07-0140/0170/0210/0260-7

Cable connection terminals of R7 units with brake resistors (+D151) and du/dt filter (+E205)

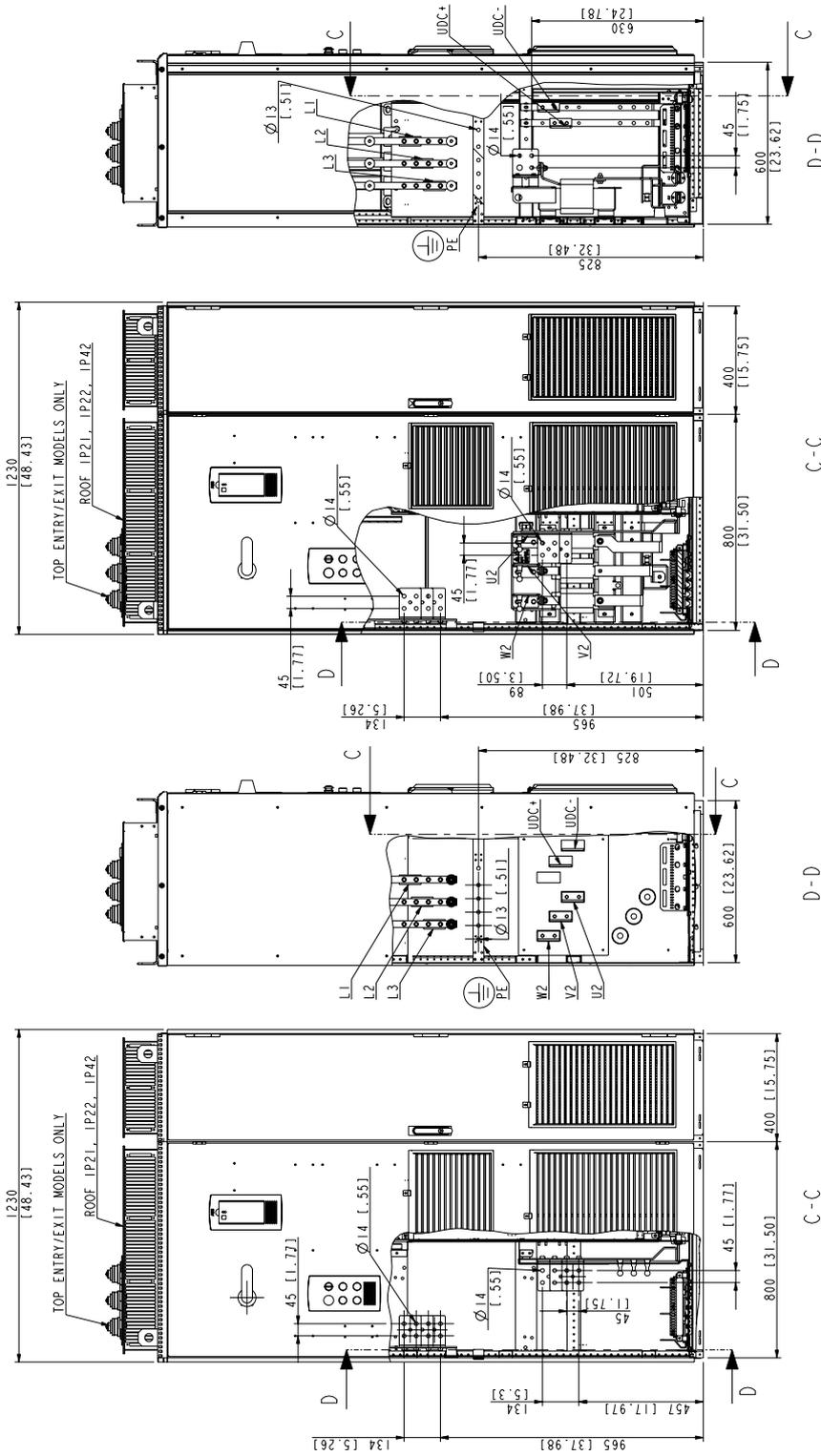

FRAME SIZE R7 WITH Du/Dt FILTER FOCH 0260-70 AND BRAKE RESISTOR IxSAFURxxx (E205 IDB1)
 400V: ACS800-07-040/070/020-3
 500V: ACS800-07-070/020/0260-5
 690V: ACS800-07-040/070/020/0260-7

FRAME SIZE R7 WITH BRAKE RESISTOR IxSAFURxxx (IDB1)
 400V: ACS800-07-040/070/020-3
 500V: ACS800-07-070/020/0260-5
 690V: ACS800-07-040/070/020/0260-7



68249601_2/3

Frame size R8

Dimensional drawings of cable connection terminals and units with optional EMC filter, du/dt filter and brake resistors are shown below.

Types ACS800-07-0260/0320-3, -0320/0400/0440/0490-5, -0490/0550/0610-7 with brake resistors (+D151)

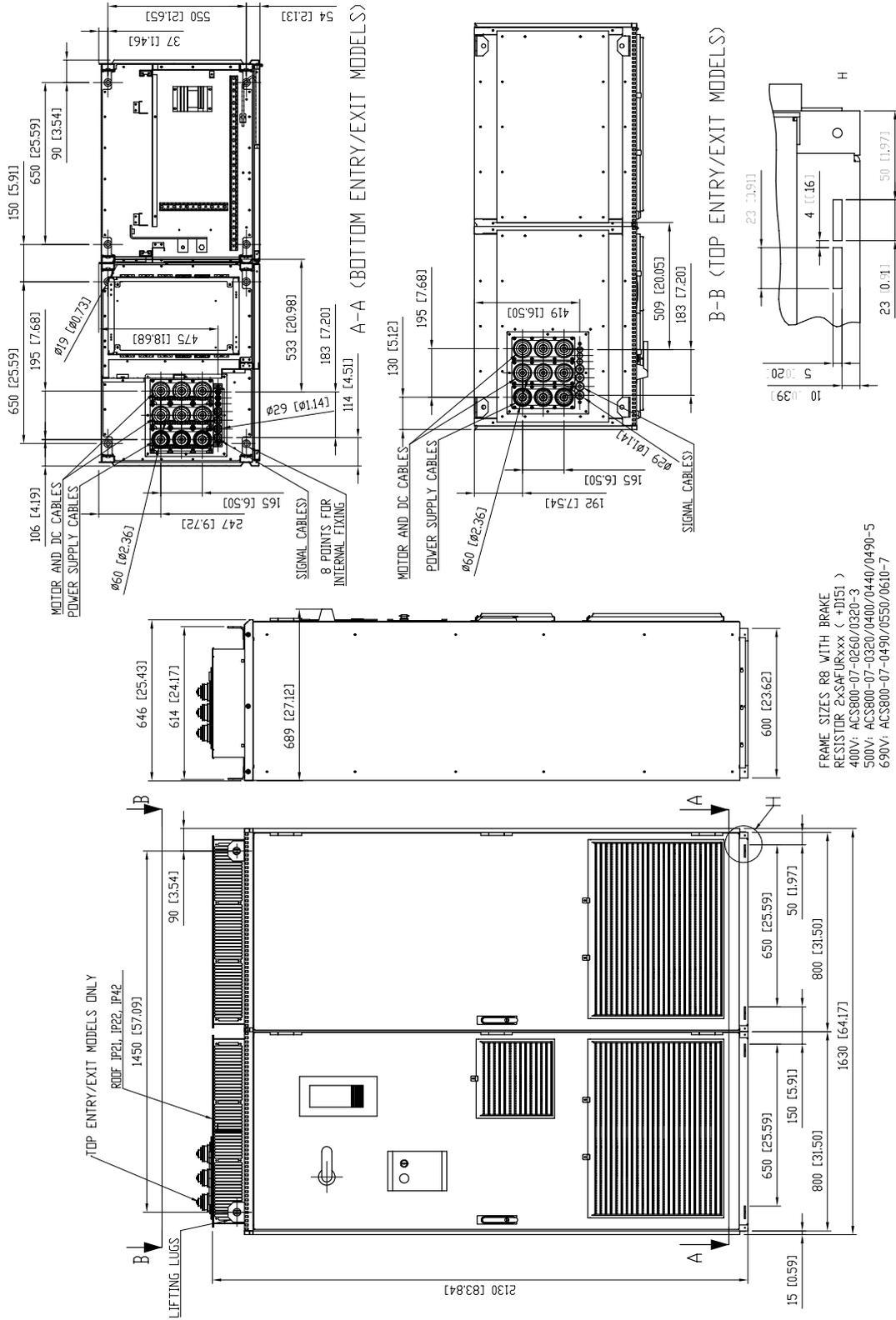

68249465_1/4 B

Cable connection terminals of R8 units with du/dt filter (+E205)

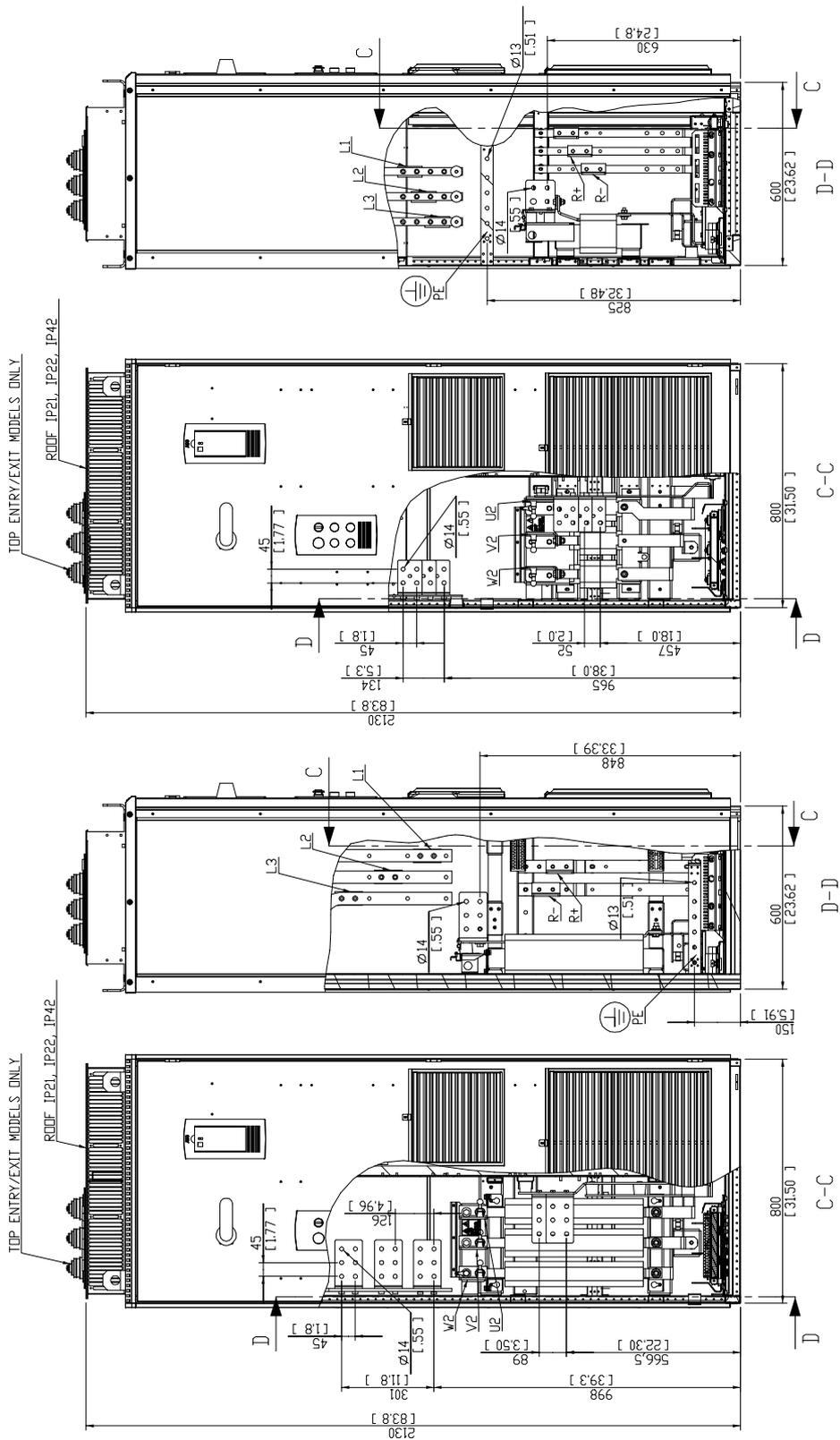

FRAME SIZE R7 WITH du/dt FILTER
 (+E205)
 ACS800-07/1/7-0170-5 ... -0260-5
 ACS800-07/1/7-0140-7 ... -0260-7

FRAME SIZE R8 WITH du/dt FILTER
 (+E205)
 ACS800-07/1/7-0320-5 ... -0610-5
 ACS800-07/1/7-0320-7 ... -0610-7



Cable connection terminals of types ACS800-07-0320/0400/0440-7 with brake resistors (+D151)

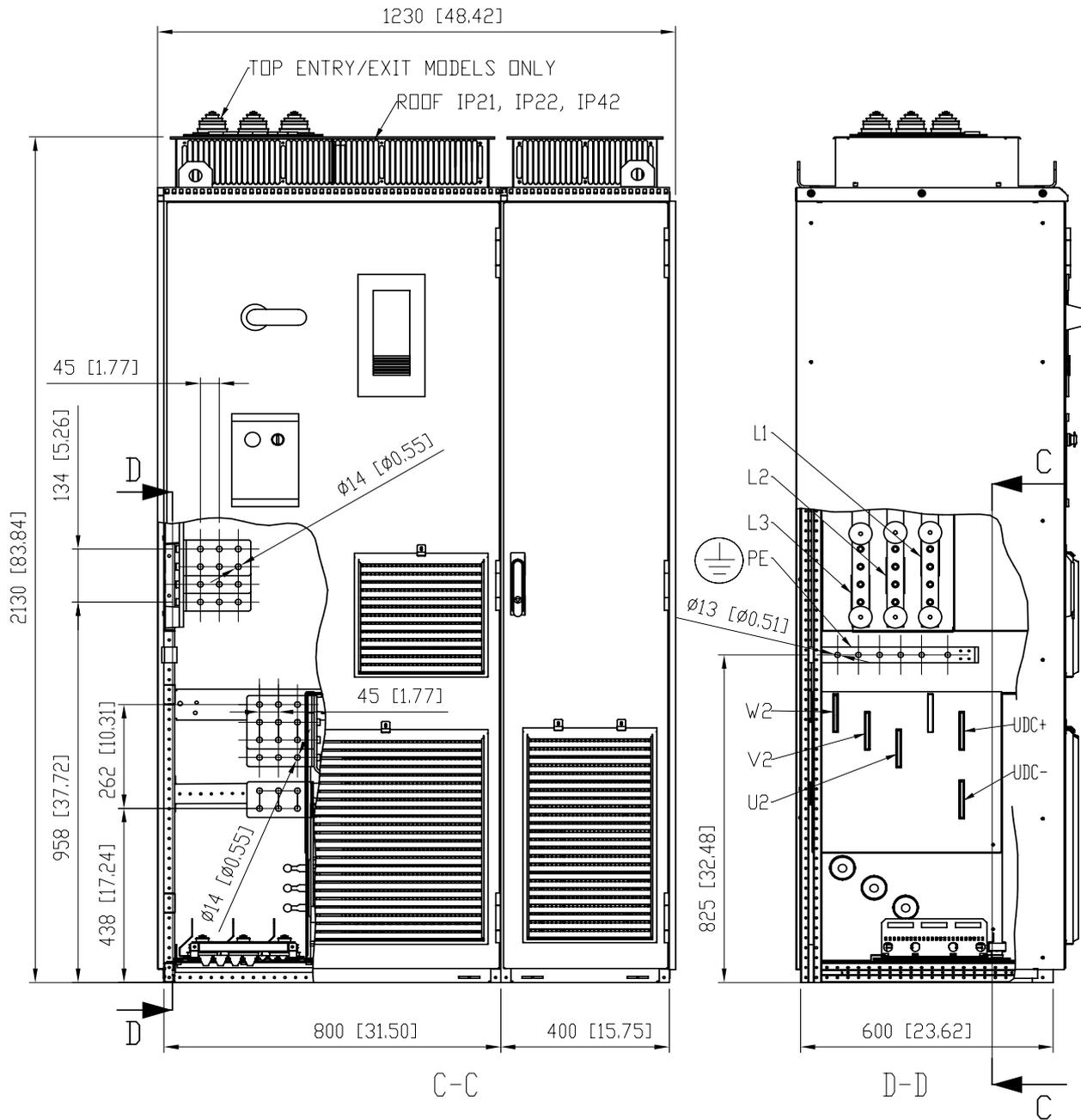

FRAME SIZE R8 WITH BRAKE
RESISTOR
1xSAFURxxx (+D151)
690V: ACS800-07-0320/0400/0440-7

68249601_3/3 B

Cable connection terminals of types ACS800-07-0320/0400/0440-7 with brake resistors (+D151) and du/dt filter (+E205)

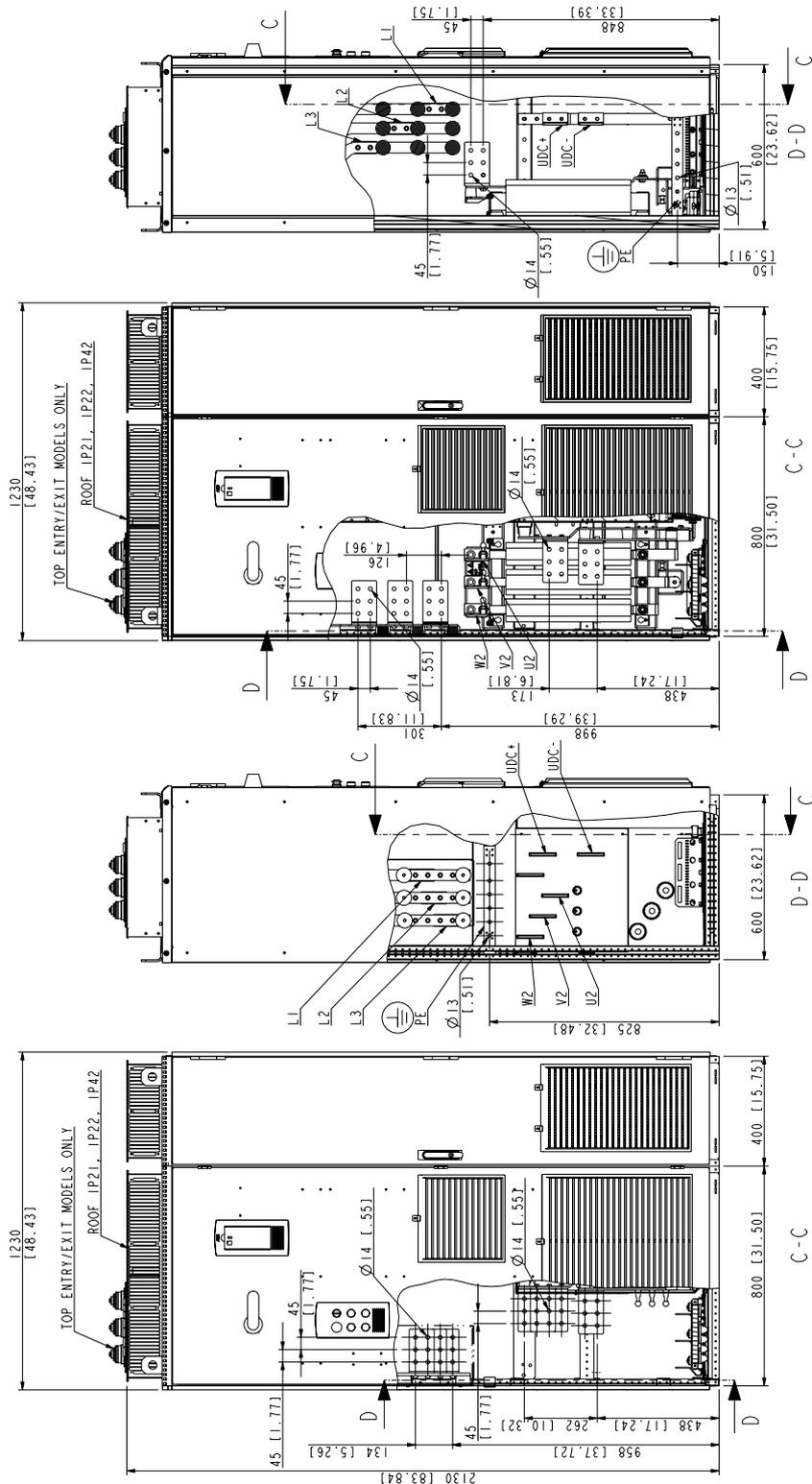

FRAME SIZE R8 WITH DU/Dt FILTER FOCH 060-70 AND
BRAKE RESISTOR 1xSAFURxxx (E205 1051)
690V: ACS800-07-0320/0400/0440-7

FRAME SIZE R8 WITH BRAKE RESISTOR
1xSAFURxxx (051)
690V: ACS800-07-0320/0400/0440-7



68249601_3/3B

Cable connection terminals of types ACS800-07-0260/0320-3, -0320/0400//0440/0490-5, -0490/0550/0610-7 with brake resistors (+D151)

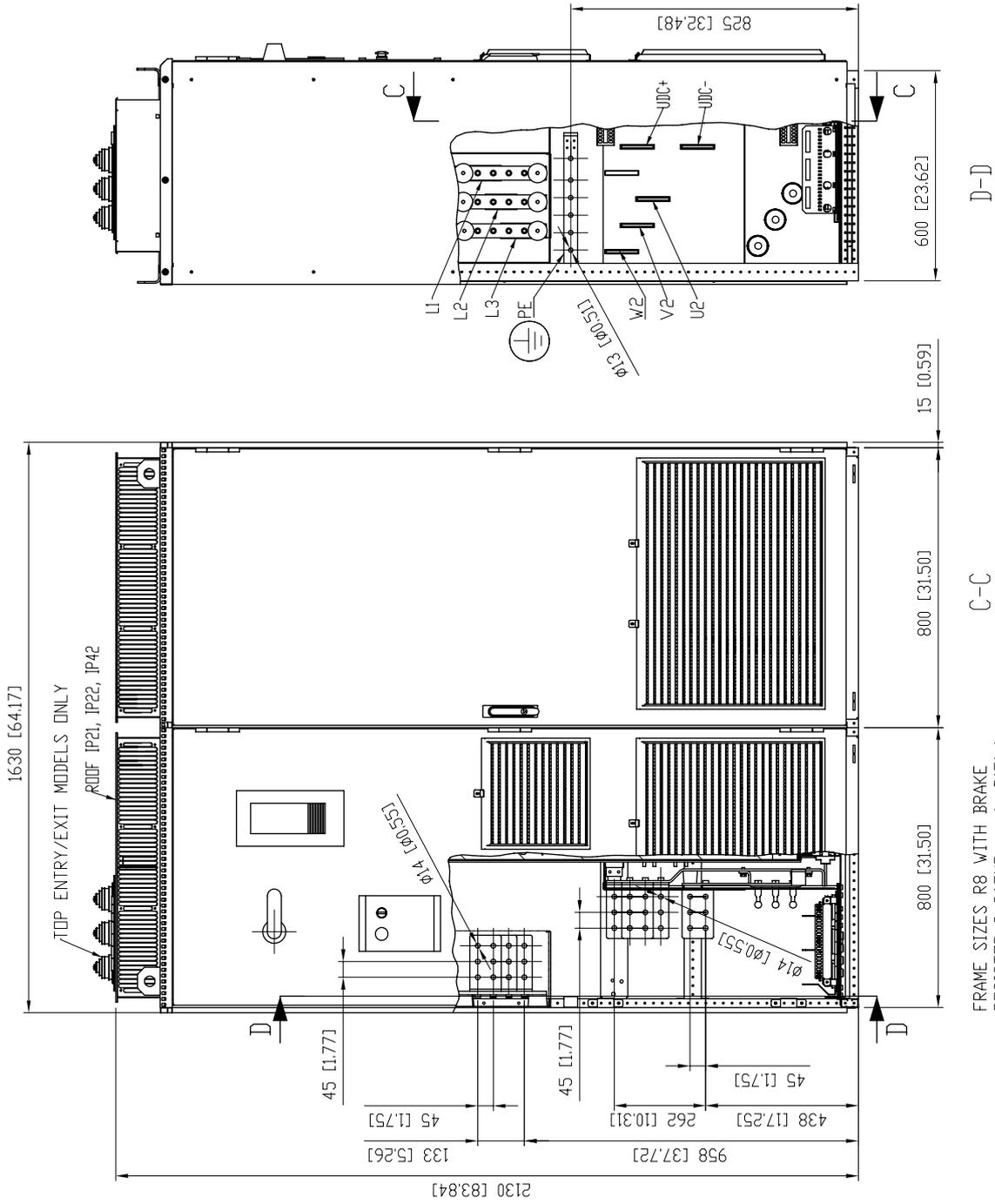

FRAME SIZES R8 WITH BRAKE
 RESISTOR 2xSAFURxxx (+D151)
 400V: ACS800-07-0260/0320-3
 500V: ACS800-07-0320/0400/0440/0490-5
 690V: ACS800-07-0490/0550/0610-7

68249465_2/4 B

Cable connection terminals of types ACS800-07-0400/0440/0490-3, -0550/0610-5 with brake resistors (+D151)

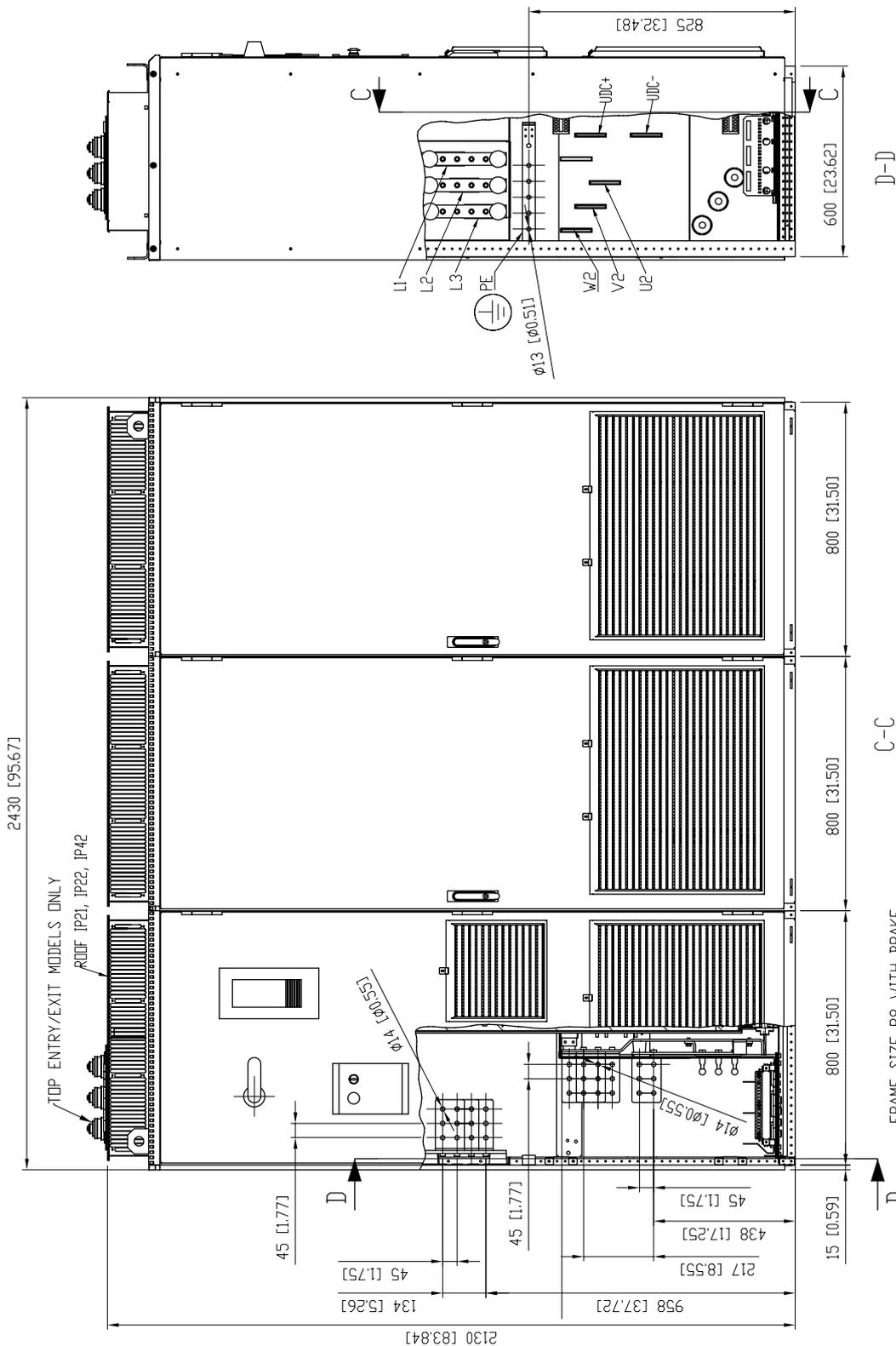

FRAME SIZE R8 WITH BRAKE
 RESISTOR 4xSAF-URxxx (+D151)
 400V: ACS800-07-0400/0440/0490-3
 500V: ACS800-07-0550/0610-5

68249597_2/3 B

Cable connection terminals of types ACS800-07-0260/-0320-3, -0320/-0400/0440/0490-5, -0490/0550/0610-7 with brake resistors (+D151) and du/dt filter (+E205)

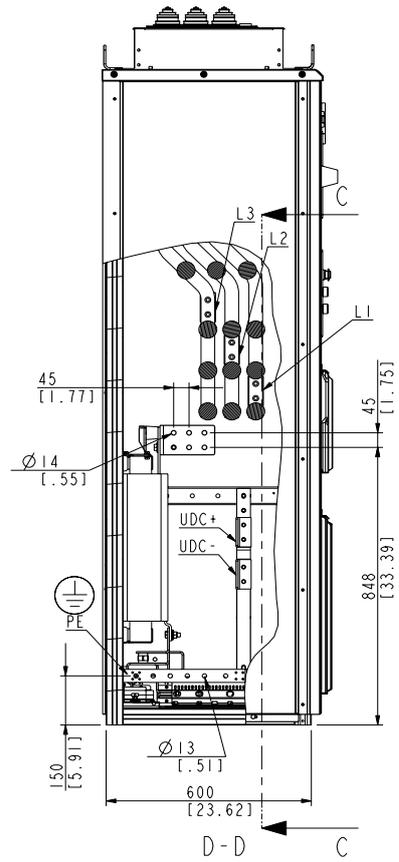
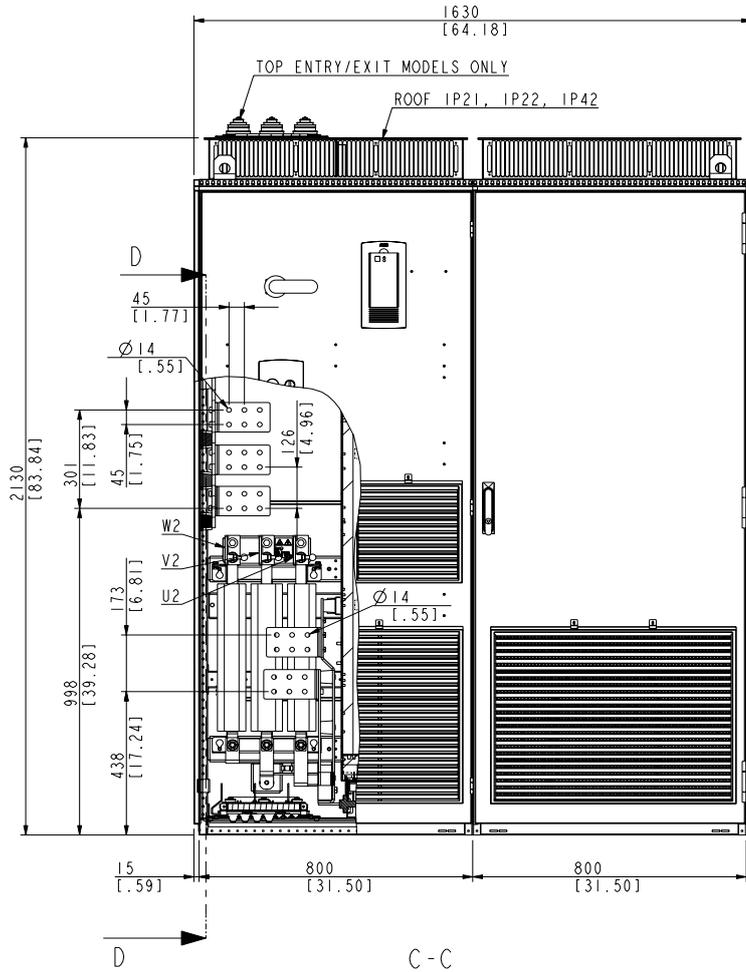

FRAME SIZE R8 WITH Du/Dt FILTER FOCH 0610-70 AND BRAKE RESISTOR 2xSAFURxxx (+E205 +D151)
 400V: ACS800-07-0260/0320-3
 500V: ACS800-07-0320/0400/0440/0490-5
 690V: ACS800-07-0490/0550/0610-7



Cable connection terminals of types ACS800-07-0400/0440/0490-3, -0550/0610-5 with brake resistors (+D151) and du/dt filter (+E205)

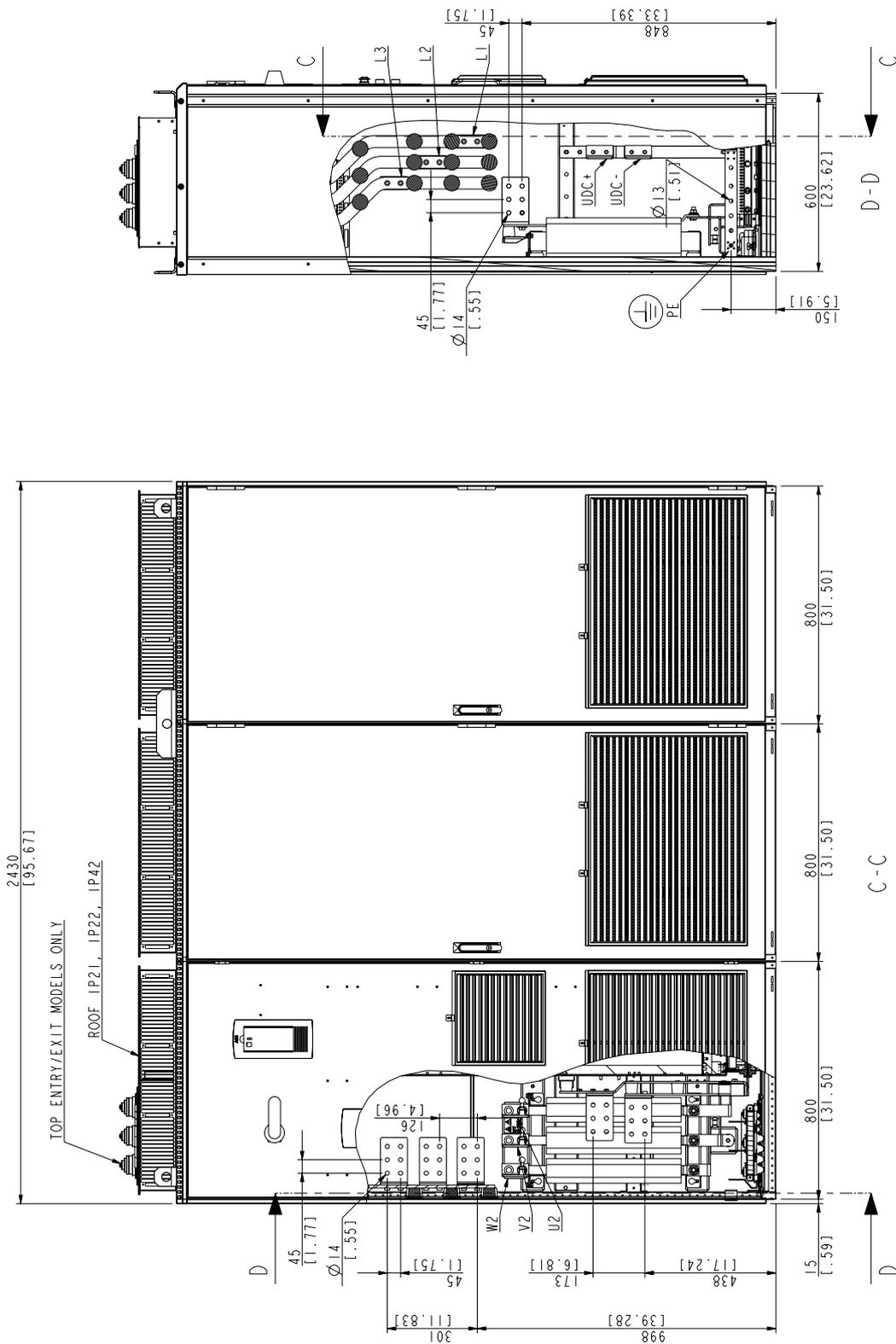

FRAME SIZE R8 WITH du/dt FILTER FOCH 0610-70 AND
 BRAKE RESISTOR 4xSAFURxxx (+D151)
 400V: ACS800-07-0400/0440/0490-3
 500V: ACS800-07-0550/0610-5

68249597_3/3

Fastening of marine cabinets (+C121)

Dimensional drawings for the fastening of marine cabinets are shown below.

Frame size R6: various cabinet widths and combinations

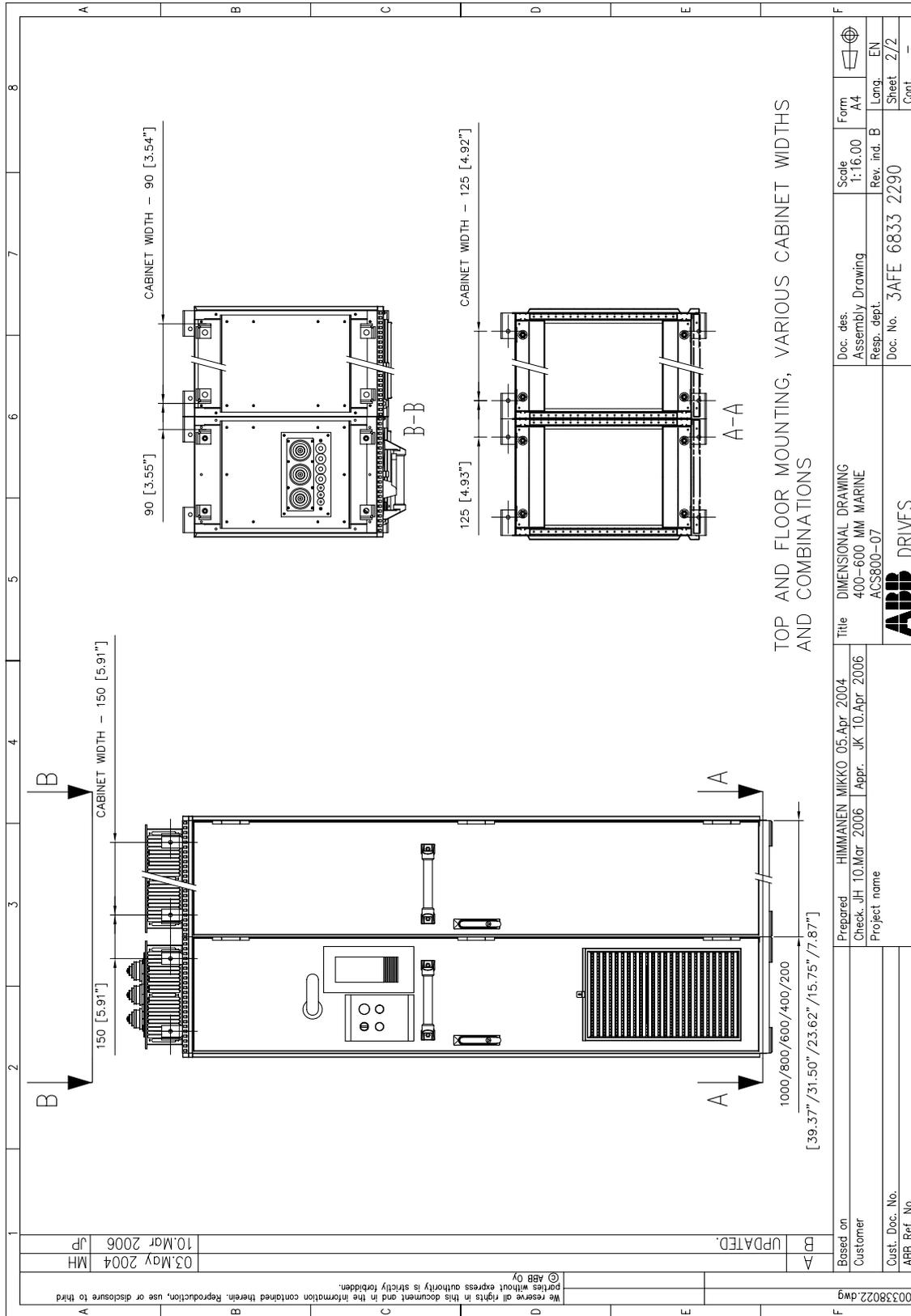

68332290_2/2 B

Frame sizes R7 and R8: various cabinet widths and combinations

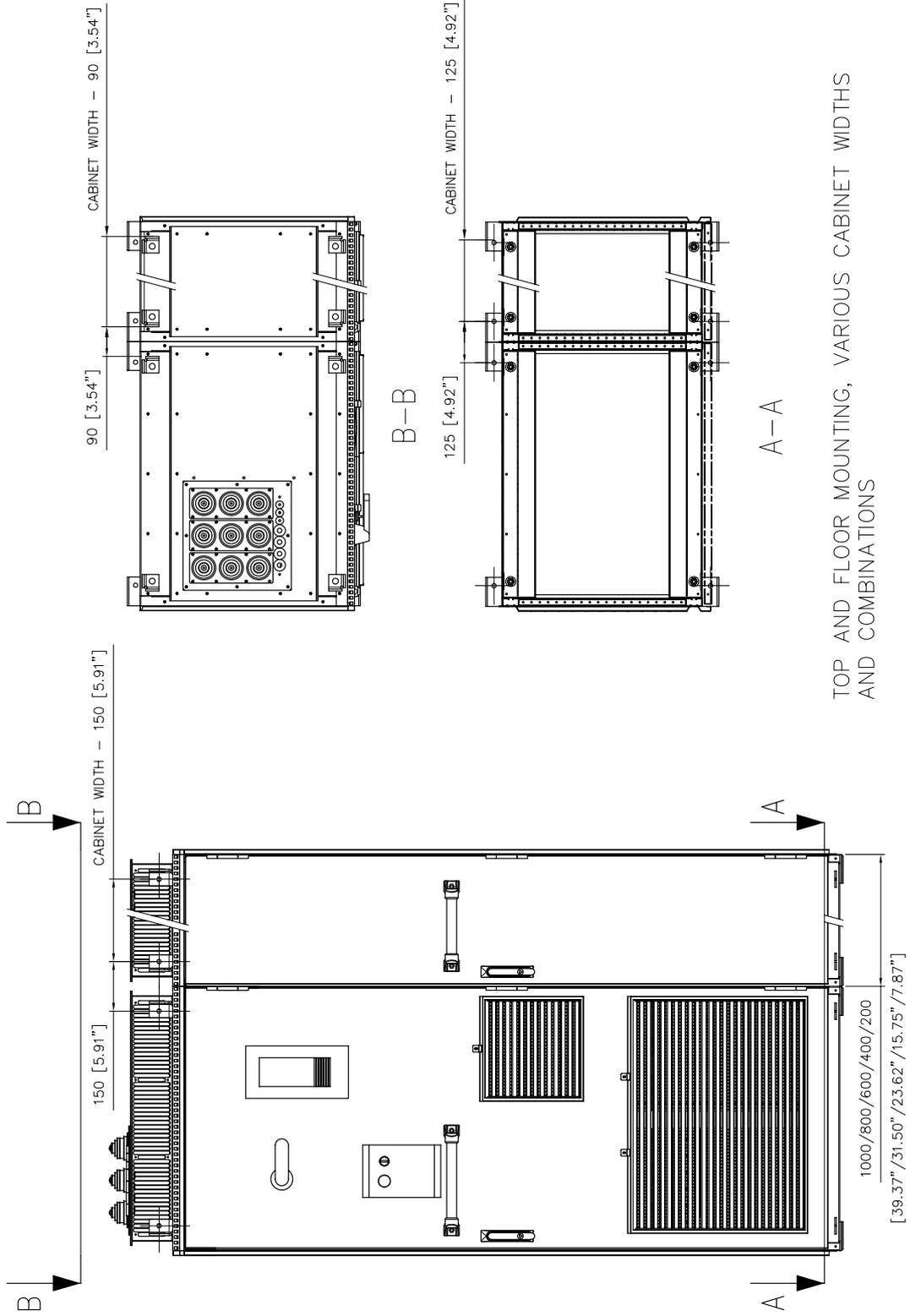

TOP AND FLOOR MOUNTING, VARIOUS CABINET WIDTHS AND COMBINATIONS

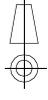

68332087_2/2 B

Dimensional drawings (USA)

Dimensional drawings of ACS800-U7 units are shown below.

Frame size R6 (USA)

Dimensional drawings of frame size R6 units are shown below.

Types ACS800-U7-0100/0120/0140-5 and -0070/0100/0120-7

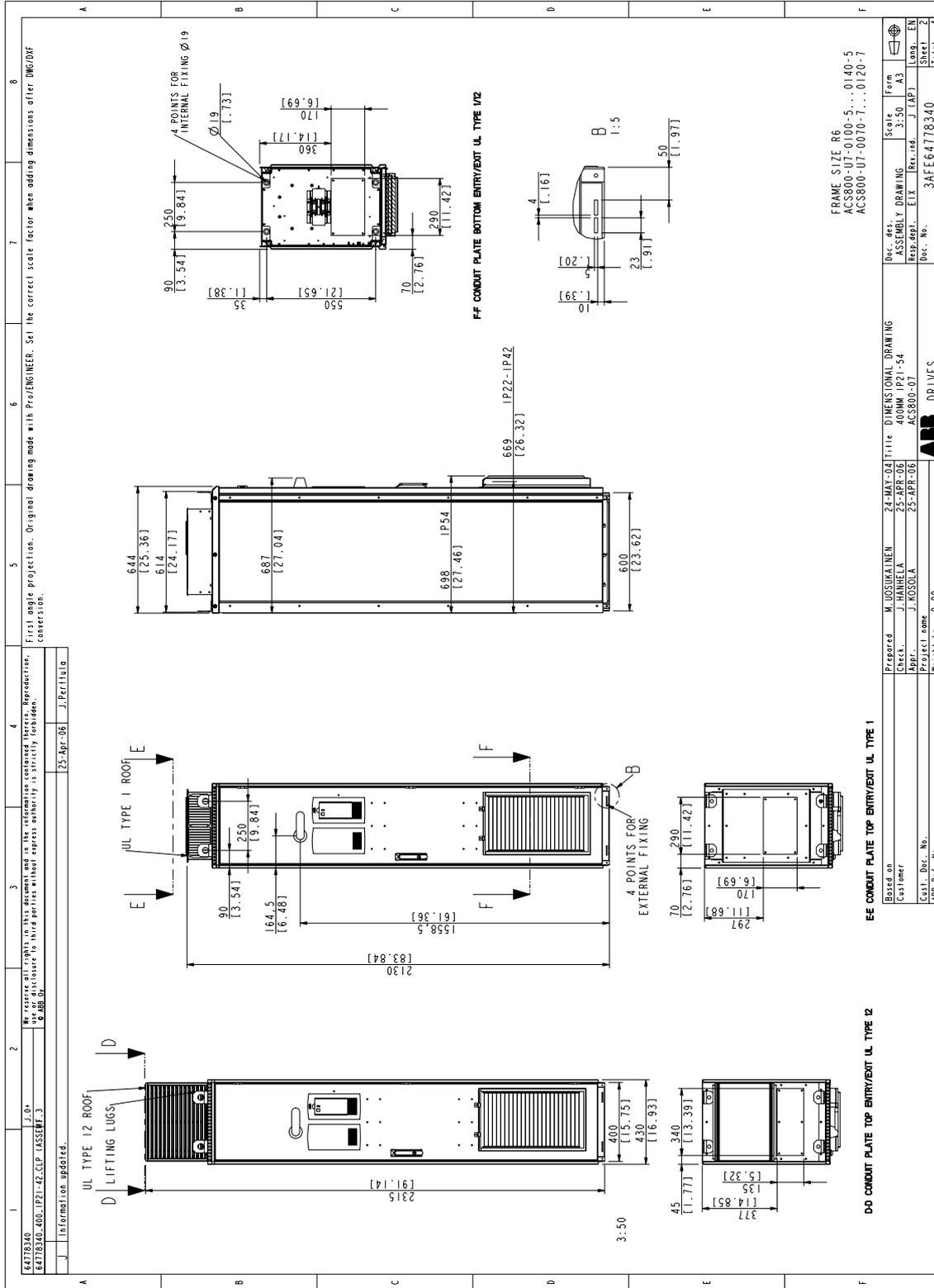

64778340_2/4 H

Frame sizes R7 and R8 (USA)

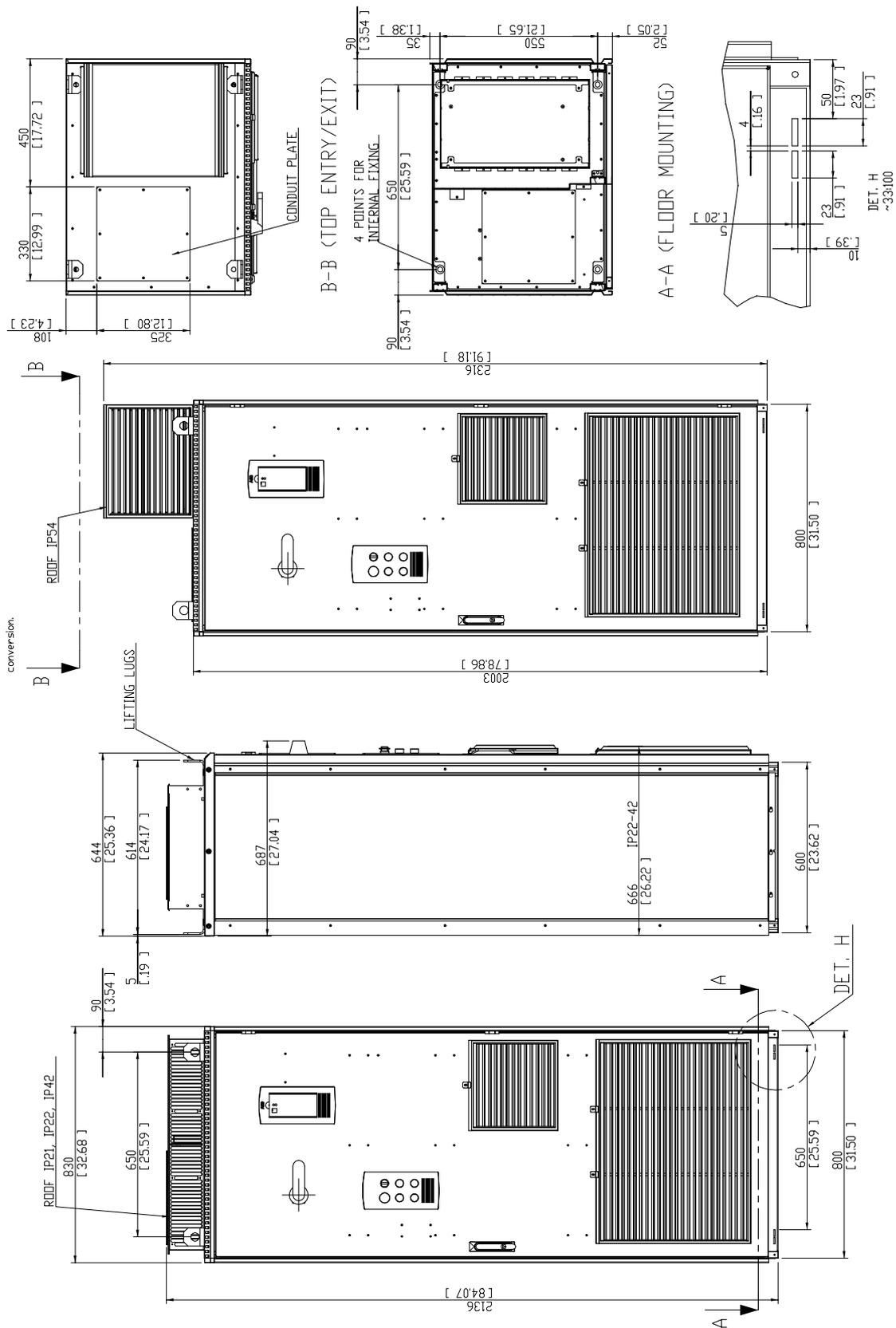

FRAME SIZE R7 AND
R8
ACS800-U7-0170-5...-0610-5
ACS800-U7-0140-7...-0610-7

Frame size R7 with EMC filter (+E202, UL type 1)

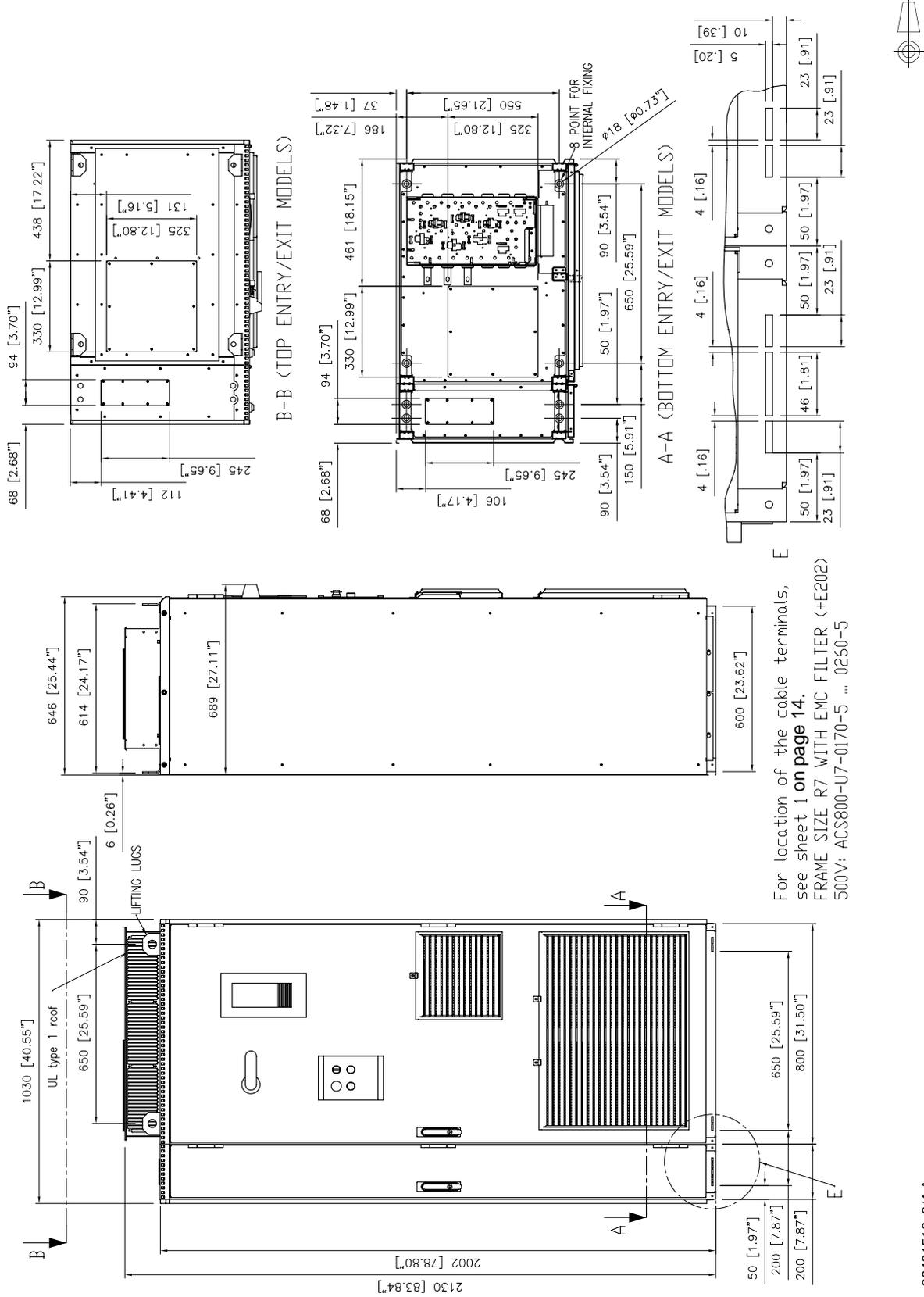

Frame size R7 with EMC filter (+E202, UL type 12)

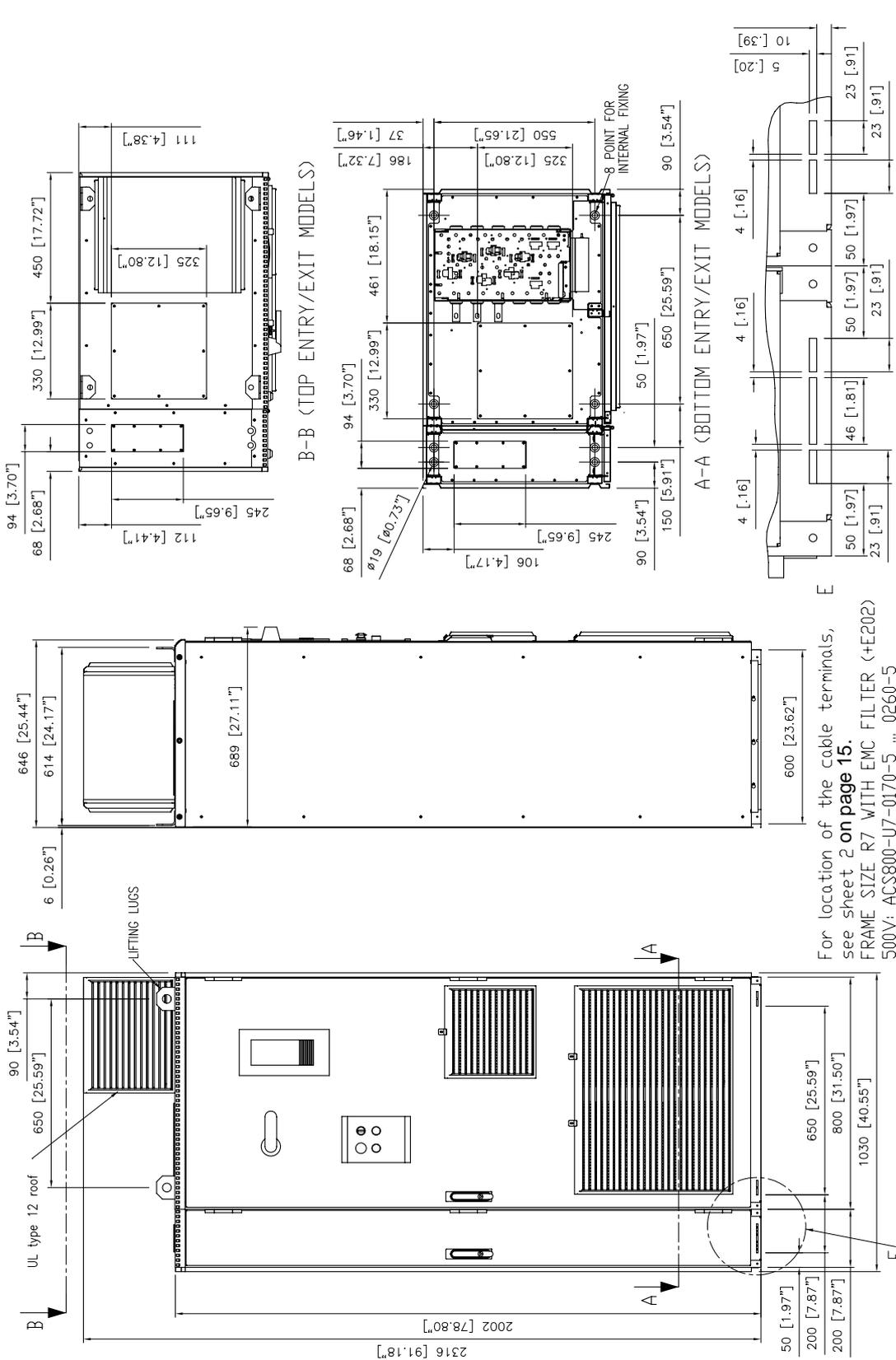

For location of the cable terminals, see sheet 2 on page 15.
 FRAME SIZE R7 WITH EMC FILTER (+E202)
 500V: ACS800-U7-0170-5 ... 0260-5



68401518_4/4 A

Frame size R8 with EMC filter (+E202, UL type 1)

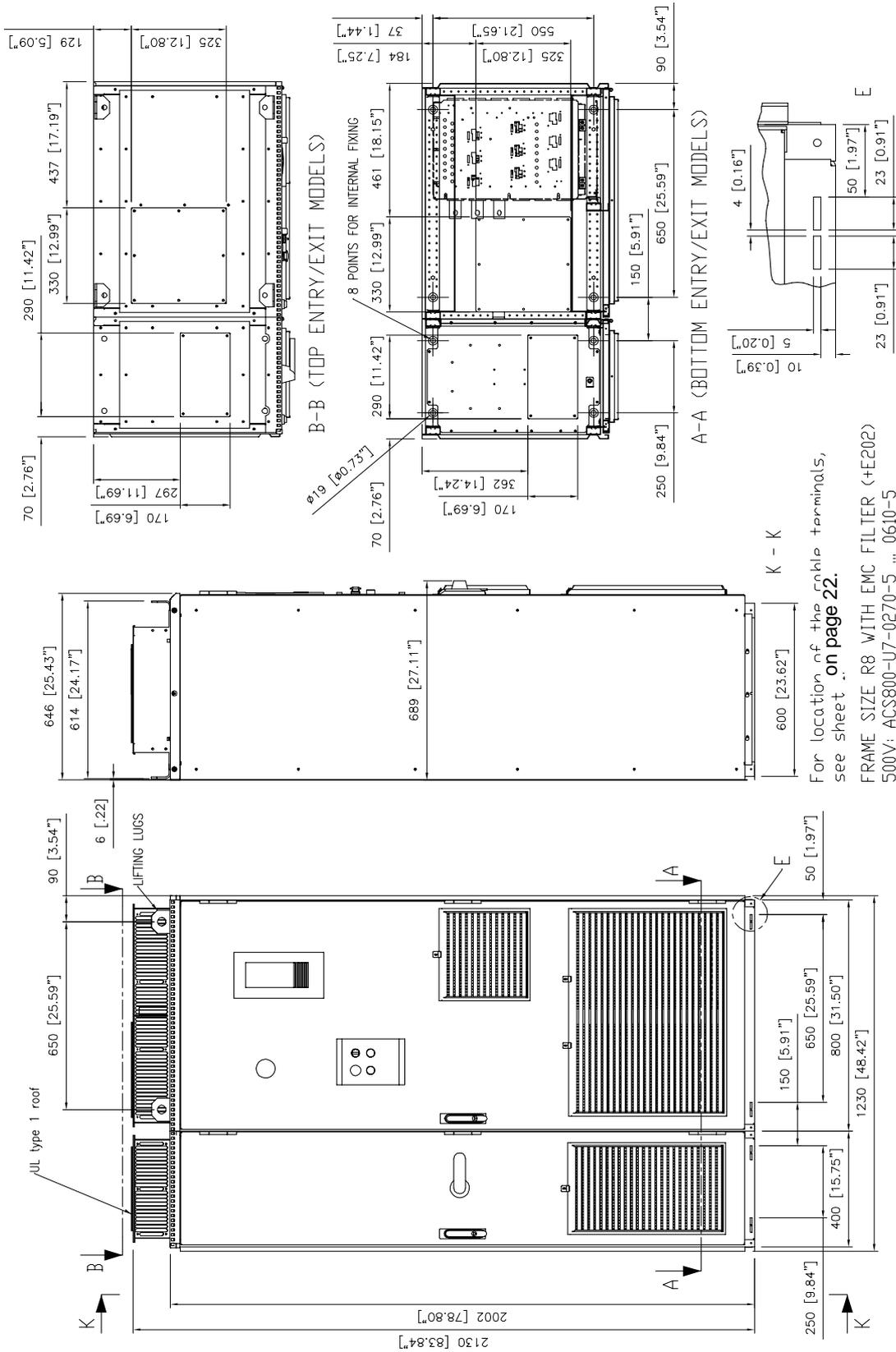

68401518_3/4 A



ABB Oy
AC Drives
P.O. Box 184
FI-00381 HELSINKI
FINLAND
Telephone +358 10 22 11
Fax +358 10 22 22681
Internet <http://www.abb.com>

ABB Inc.
Automation Technologies
Drives & Motors
16250 West Glendale Drive
New Berlin, WI 53151
USA
Telephone 262 785-3200
800-HELP-365
Fax 262 780-5135

ABB Beijing Drive Systems Co. Ltd.
No. 1, Block D, A-10 Jiuxianqiao Beilu
Chaoyang District
Beijing, P.R. China, 100015
Telephone +86 10 5821 7788
Fax +86 10 5821 7618
Internet <http://www.abb.com>

3AFE64775421 Rev D EN
EFFECTIVE: 25.7.2006