

ABB industrial drives

Application guide

ACS800-01/02/04/11/31/104/104LC Safe torque off function (+Q967)



Power and productivity
for a better world™



Application guide

ACS800-01/02/04/11/31/104/104LC Safe torque off function
(+Q967)

Table of contents



3. Installation



4. Start-up and validation



Table of contents

1. Basics

Option codes (plus codes)	8
---------------------------------	---

2. Program features, settings and diagnostics

Operation of the STO function and its diagnostics function	9
STO status indications	10
STO function activation and indication delays	10
Module delays only	10
Delays with typical STO safety relay	10

3. Installation

Example wiring diagrams	11
Without safety relay	12
Frame sizes R2 to R6	12
Frame sizes R7 and R8	12
Frame sizes R2i to R4i	13
Frame size R5i	13
Frame size R7i	14
Frame size R8i	14
Liquid-cooled modules of frame sizes R7i and R8i	15
Connecting the STO switch without safety relay	15
With safety relay	16
Frame sizes R2 to R6	16
Frame sizes R7 and R8	17
Frame sizes R2i to R4i	18
Frame size R5i	19
Frame size R7i	20
Frame size R8i	21
Connecting several drive modules to one safety relay	22

4. Start-up and validation

Validating the operation of a safety function	23
Authorized person	23
Acceptance test reports	23
Start-up checklist	24

5. Maintenance and fault tracing

Maintenance	25
Warning messages generated by the drive	25
Fault messages generated by the drive	26



6. Technical data

STO components	27
ASTO-11/21 board	27
ASTO-11 and 21 board	27
ASTO-11 board	27
ASTO board according to frame size of the module	28
Dimensions of the ASTO board with enclosure	28
STO safety relay type	29
Push-button to be used with emergency stop	29
STO switch to be used with Prevention of unexpected start-up function implemented with STO	29
STO data related to safety standards (safety relay not included)	29
Frame size R2/R2i	29
Frame size R3/R3i	29
Frame size R4/R4i	30
Frame size R5/R5i	30
Frame size R6	30
Frame size R7/R7i/R8/R8i	30
Multiples of frame size R8i	30
Frame size 2×R8i	30
Frame size 3×R8i	30
Frame size 4×R8i	30
Frame size 5×R8i	31
Frame size 6×R8i	31
Frame size 7×R8i	31
Frame size 8×R8i	31
Frame size 9×R8i	31
Frame size 10×R8i	31
Frame size 11×R8i	31
Frame size 12×R8i	31
Abbreviations	32
TÜV certificate	33
Declarations of Conformity	34

Further information

Product and service inquiries	43
Product training	43
Providing feedback on ABB Drives manuals	43
Document library on the Internet	43





Basics

The drive supports the Safe torque off (STO) function according to standards EN 61800-5-2:2007; EN ISO 13849-1:2008, IEC 61508, IEC 61511:2004 and EN 62061:2005. The function also corresponds to prevention of unexpected start-up of EN 1037.

The STO may be used where power removal is required to prevent an unexpected start. The function disables the control voltage of the power semiconductors of the drive output stage, thus preventing the inverter from generating the voltage required to rotate the motor (see diagram below). By using this function, short-time operations (like cleaning) and/or maintenance work on non-electrical parts of the machinery can be performed without switching off the power supply to the drive.

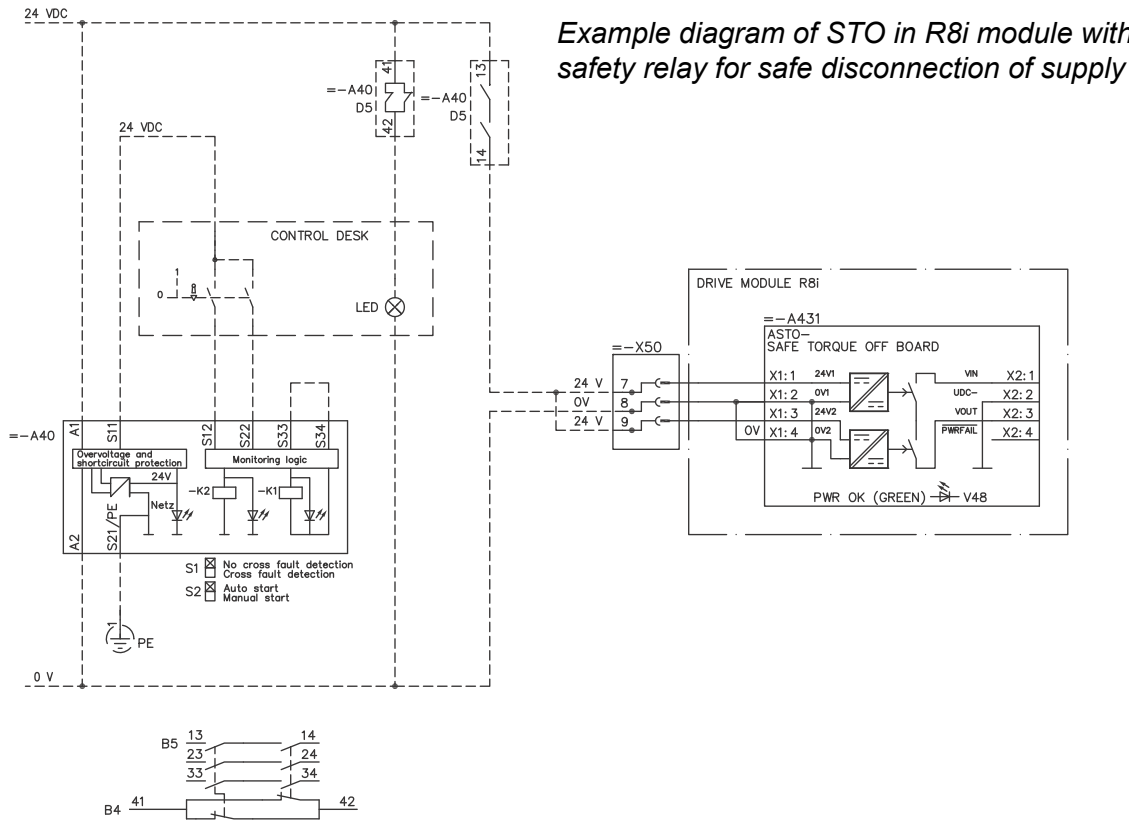

⚡ WARNING! The Safe torque off function does not disconnect the voltage of the main and auxiliary circuits from the drive. Therefore maintenance work on electrical parts of the drive or the motor can only be carried out after isolating the drive system from the main supply.

Note: The Safe torque off function can be used for stopping the drive in emergency stop situations. In the normal operating mode, use the Stop command instead. If a running drive is stopped by using the function, the drive will trip and stop by coasting. If this is not acceptable, e.g. causes danger, the drive and machinery must be stopped using the appropriate stopping mode before using this function.

Note concerning permanent magnet motor drives in case of a multiple IGBT power semiconductor failure: In spite of the activation of the Safe torque off function, the drive system can produce an alignment torque which maximally rotates the motor shaft by $180/p$ degrees. p denotes the pole pair number.

Option codes (plus codes)

Options codes related to safety features are listed below.

Safety features	
Q963	Emergency Stop, stop cat. 0 without opening the main contactor/breaker
Q964	Emergency Stop, stop cat. 1 without opening the main contactor/breaker, SS1
Q967	STO Safe torque off (in module and cabinet)
Q968	Safe torque off with safety relay

2

Program features, settings and diagnostics

Operation of the STO function and its diagnostics function

When both STO inputs are energized, the STO function is in the standby state and the drive operates normally. If the STO inputs are de-energized, the STO function awakes, stops the drive and disables start. Start is possible only after the STO inputs have been energized, and any faults of the drive have been reset.

The table below describes the operation of the STO function in detail depending on:

- status of the STO inputs
- the fault or warning START INHIBI (see chapter [Maintenance and fault tracing](#)).

Status of STO inputs	When drive is	How the STO function operates	START INHIBI indication
De-energized	running	Awakes and trips the drive.	Fault
	stopped	Awakes and disables start.	Warning
One energized, other de-energized	running	Awakes and trips the drive.	Fault
	stopped	Awakes and disables start.	Warning
Energized	running or stopped	STO is on standby. Drive operates normally.	-

STO status indications

Control program	Alarm and status bits / words
System Control Program	08.02 AUX STATUS WORD bit 8 08.21 START INHIBI WORD
Standard Control Program	03.03 AUX STATUS WORD bit 8

Control program	Alarms and faults
System Control Program	09.04 ALARM WORD 1 bit 0 09.06 FAULT WORD 3 bit 5 31.02 START INHIBIT ALM
Standard Control Program	03.08 ALARM WORD 1 bit 0

See also chapter [Maintenance and fault tracing](#).

Control program	Digital / relay outputs
System Control Program	14 DIGITAL OUTPUTS Note: To be programmed by the user. For information on programming the digital outputs, see <i>ACS800 system control program firmware manual</i> [3AFE64670646 (English)].
Standard Control Program	14 RELAY OUTPUTS Note: To be programmed by the user. For information on programming the relay outputs, see <i>ACS800 standard control program firmware manual</i> [3AFE64527592 (English)].

STO function activation and indication delays

■ Module delays only

STO activation and indication delays	Typical delay	Maximum delay
STO activation delay ¹⁾	2 ms	20 ms
STO indication delay ²⁾	1.5 ms	-

¹⁾ STO activation delay = delay between de-energizing the STO input and switching off the drive output bridge

²⁾ STO indication delay = delay between de-energizing the STO input and indication of STO input de-energization

■ Delays with typical STO safety relay

STO activation and indication delays	Typical delay	Maximum delay
STO activation delay ³⁾	52 ms	70 ms
STO indication delay ⁴⁾	51.5 ms	-

³⁾ STO activation delay = delay between de-energizing the STO relay and switching off the drive output bridge

⁴⁾ STO indication delay = delay between de-energizing the STO relay and indication of STO input de-energization

3

Installation



WARNING! The supply voltage for ASTO-11C and ASTO-21C board is 24 V DC. If the board is supplied with 230 V or 115 V, the board is damaged and it needs to be replaced.

Note: Since former option +Q950 (Prevention of unexpected start-up function) uses 230 V or 115 V supply voltage, it is not possible to use it with Safe torque off function (option +Q967) or vice versa. Note this when using spare parts. Note also that Safe torque off function can not be installed to drive module afterwards (ie, after the factory assembly) due to safety life cycle requirements.

Example wiring diagrams



WARNING! For connecting the ASTO board and the module, use only wire kits delivered by ABB. If you use other cables or modify the cables, you may cause a malfunction of the drive.

Connect the cables as shown in the diagram below. For more information on the components, see chapter [Technical data](#).

■ Without safety relay

Frame sizes R2 to R6

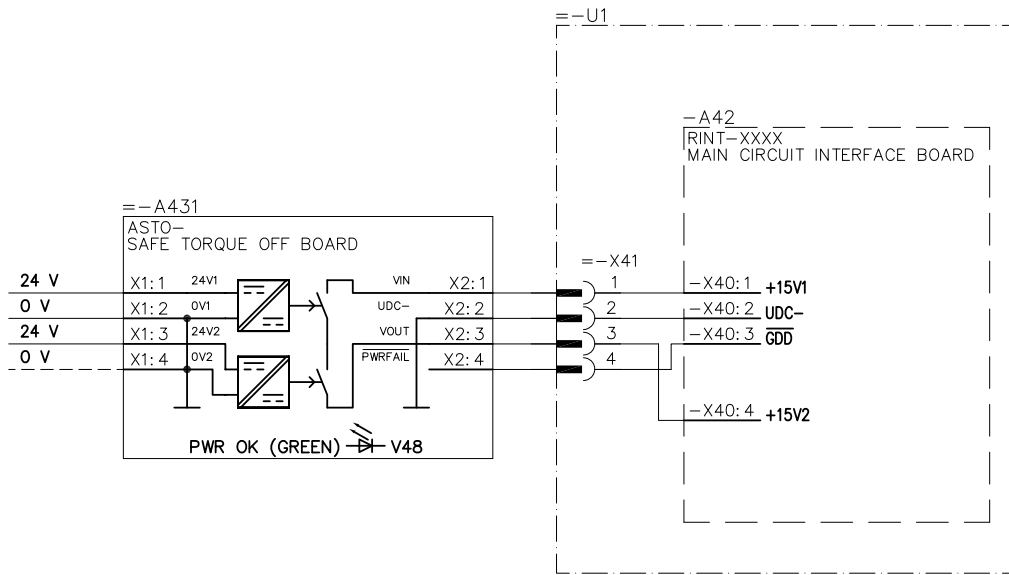

3AUA0000072542

Frame sizes R7 and R8

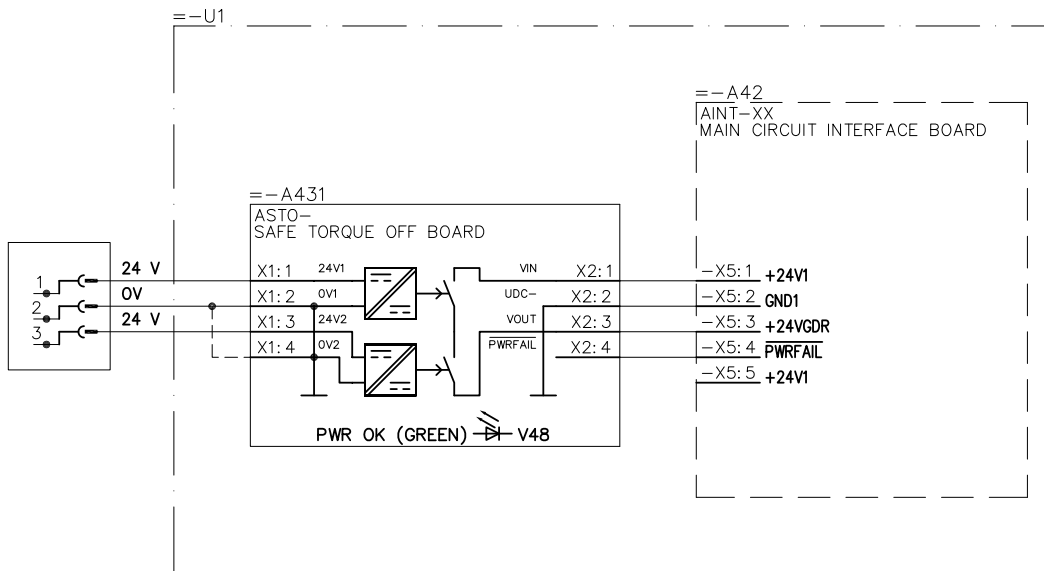

3AUA0000072272

Frame sizes R2i to R4i

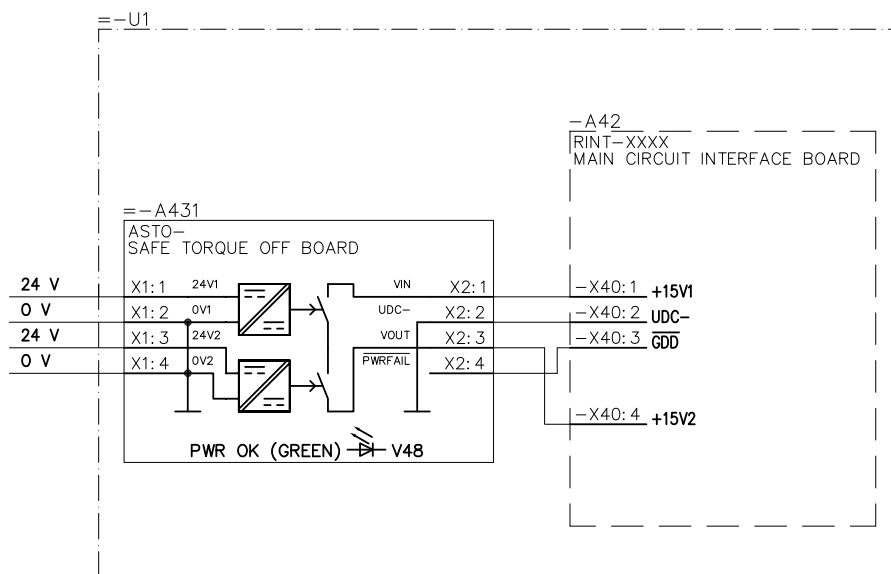

3AUA0000077408



Frame size R5i

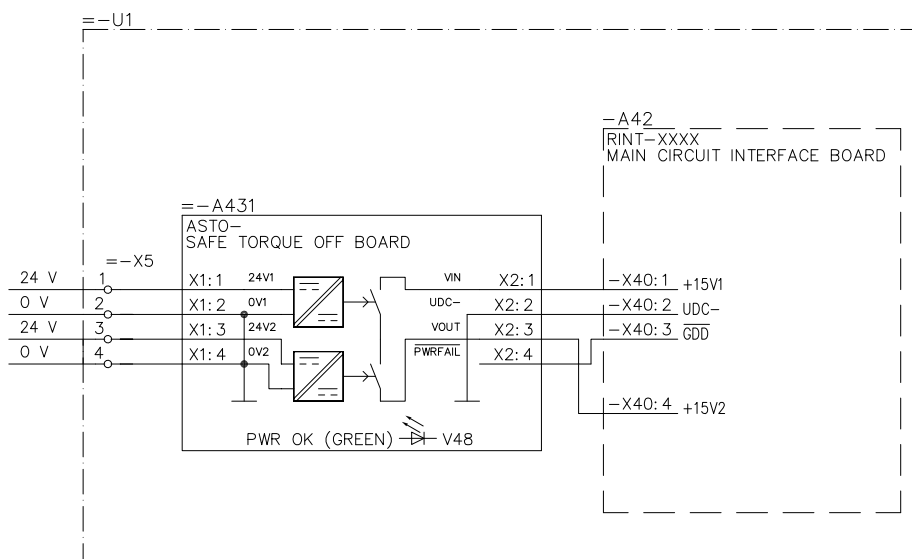

3AUA0000077456

Frame size R7i

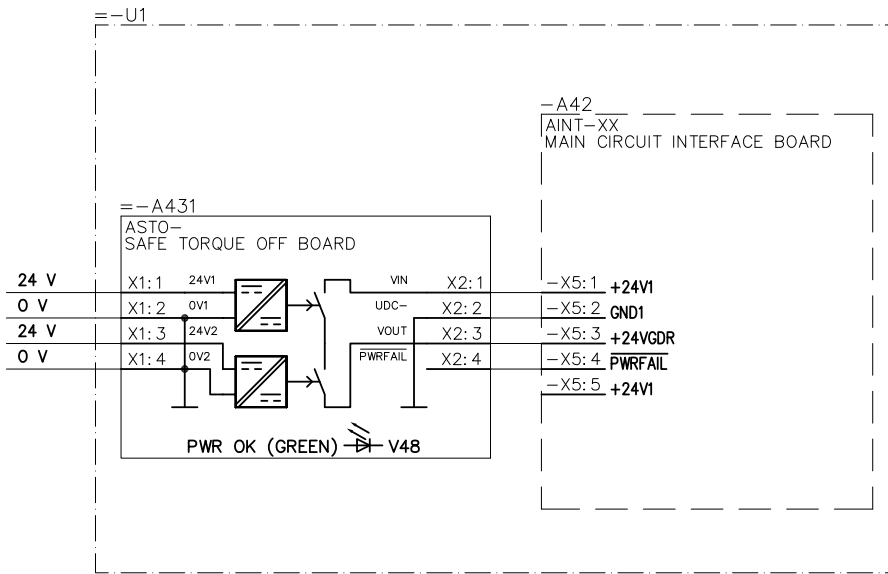

3AUA0000077458



Frame size R8i

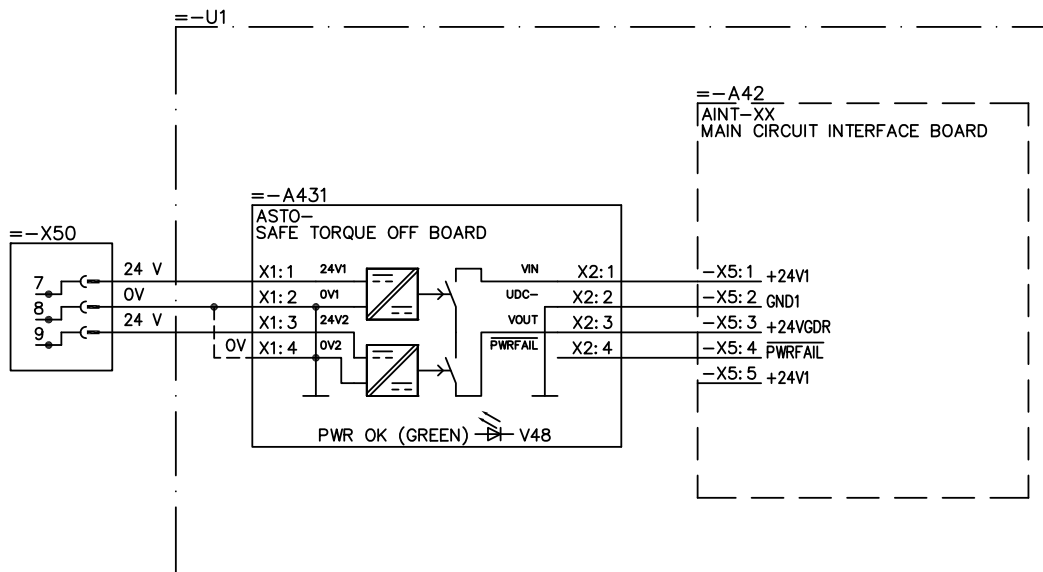

3AUA0000077457

Liquid-cooled modules of frame sizes R7i and R8i

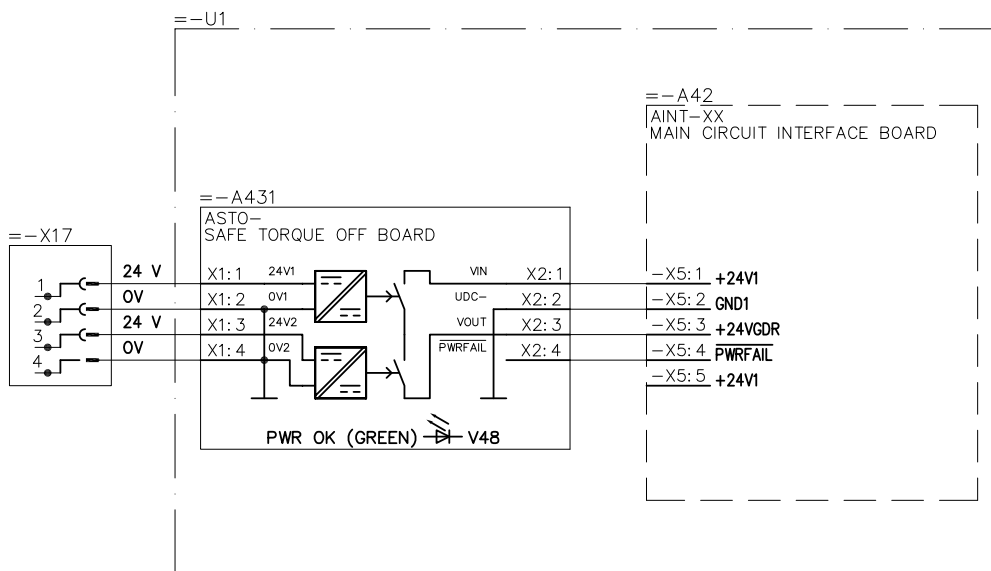

3AUA0000077142

Connecting the STO switch without safety relay

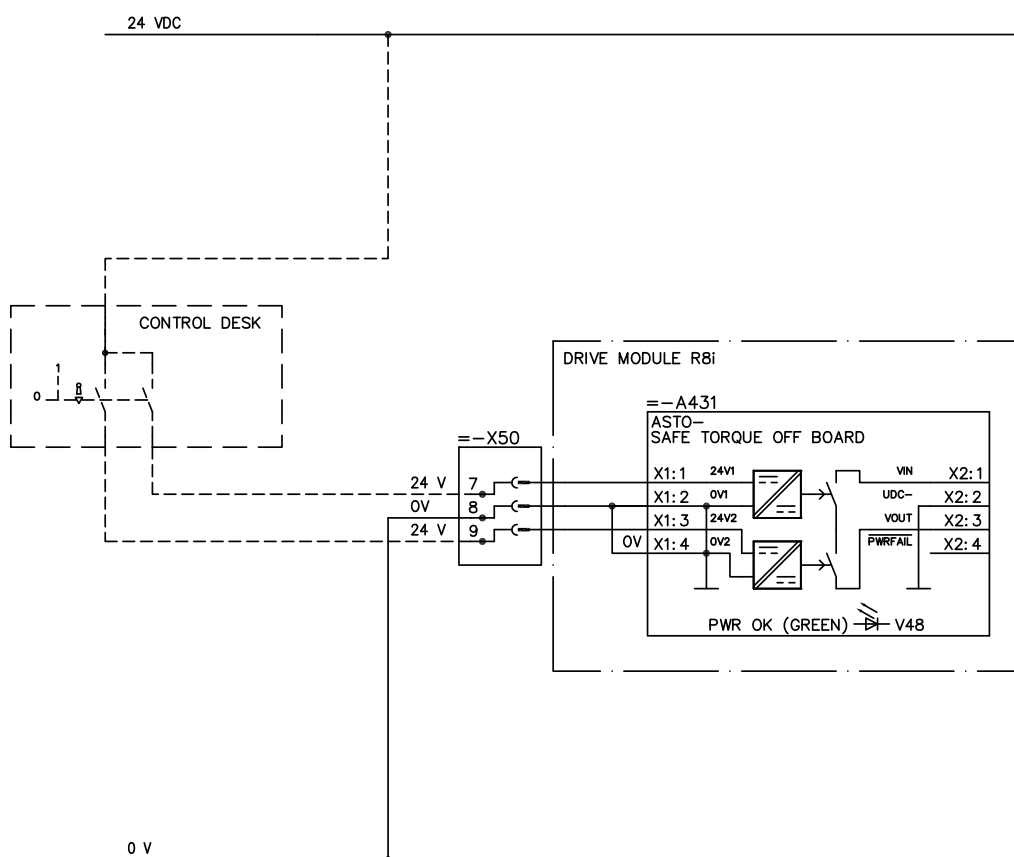

3AUA0000096631



With safety relay

Note: Safety relay is not included in the delivery when option code +Q967 is selected. In the examples below, the recommended wiring on the left-hand side of the ASTO board is outlined with a dashed line.

Frame sizes R2 to R6

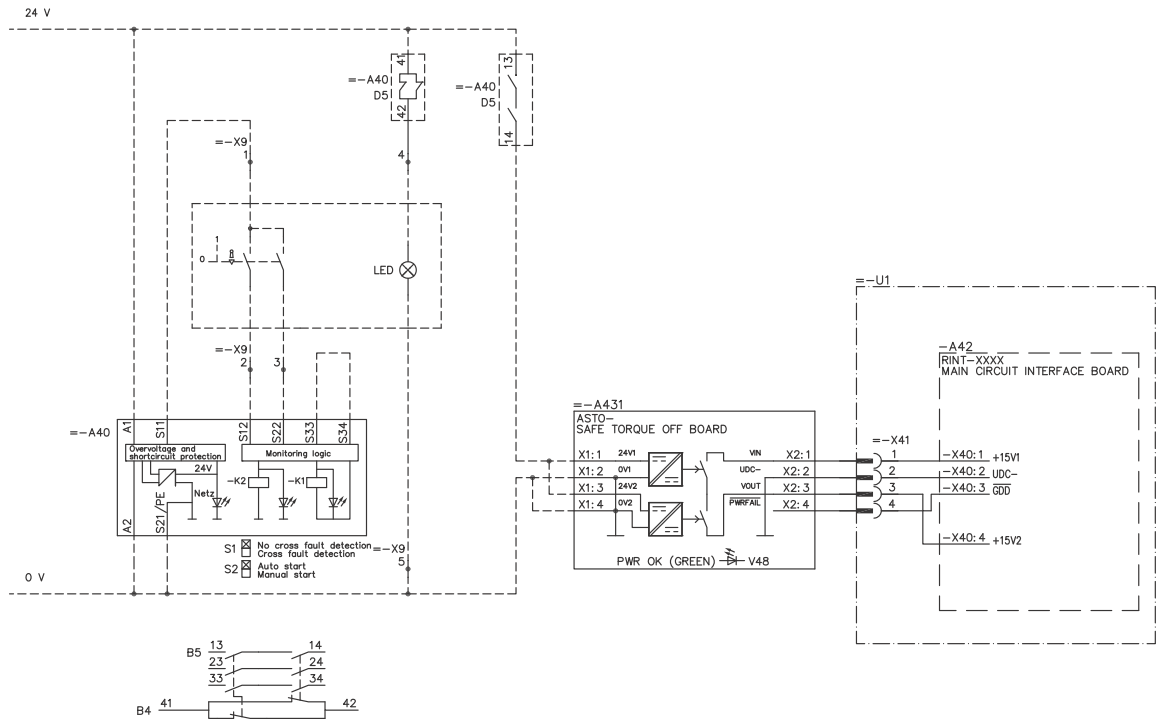

3AUA0000072271

Frame sizes R7 and R8

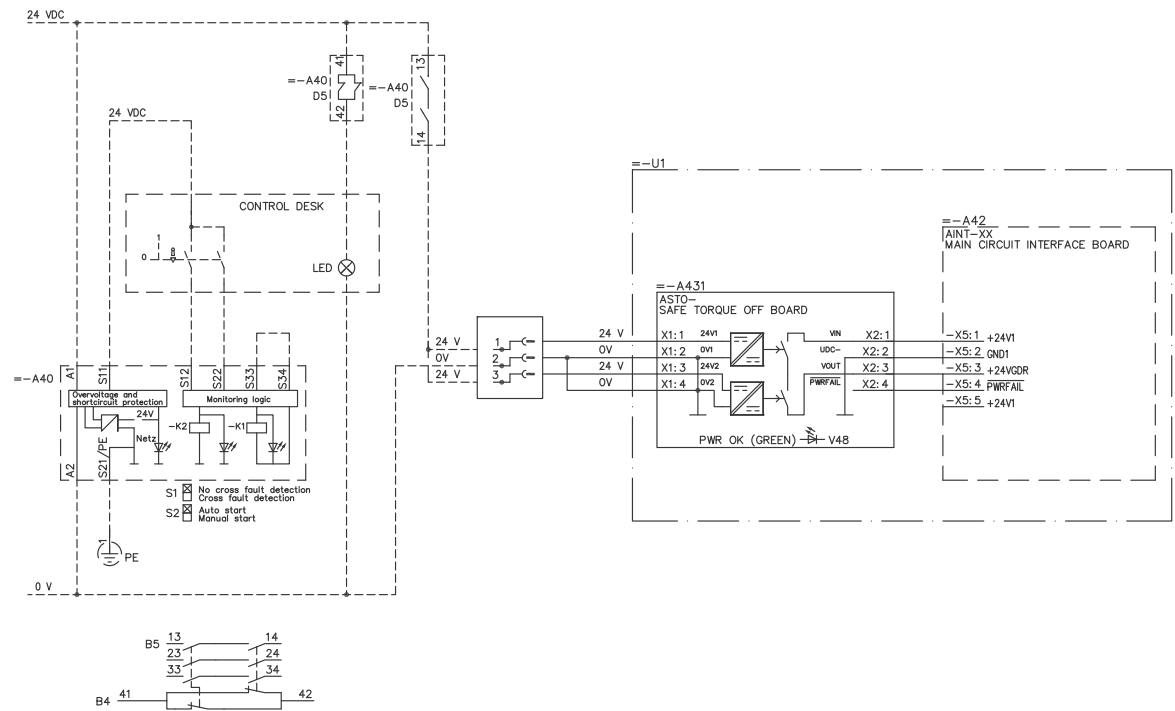

3AUA0000078208



18 Installation

Frame sizes R2i to R4i

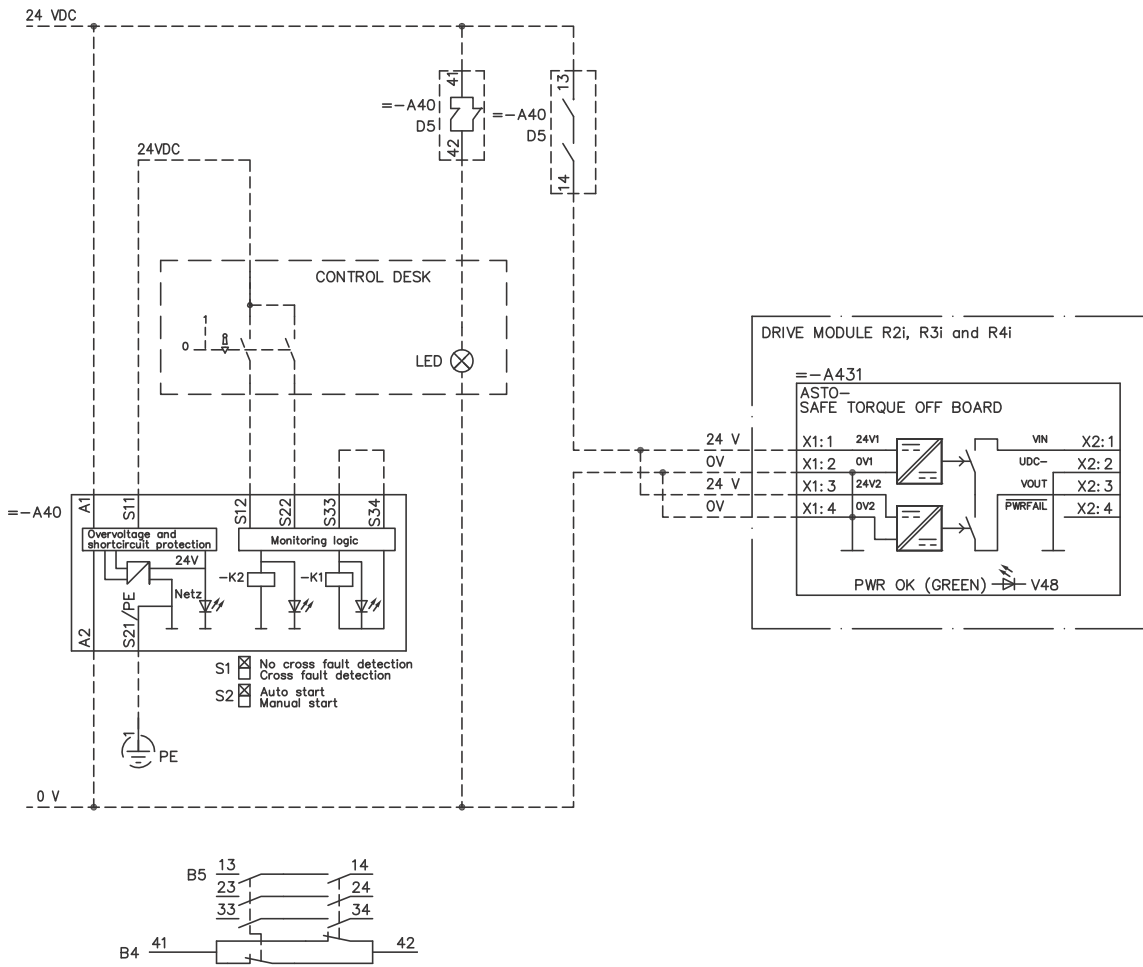

3AUA0000071122

Frame size R5i

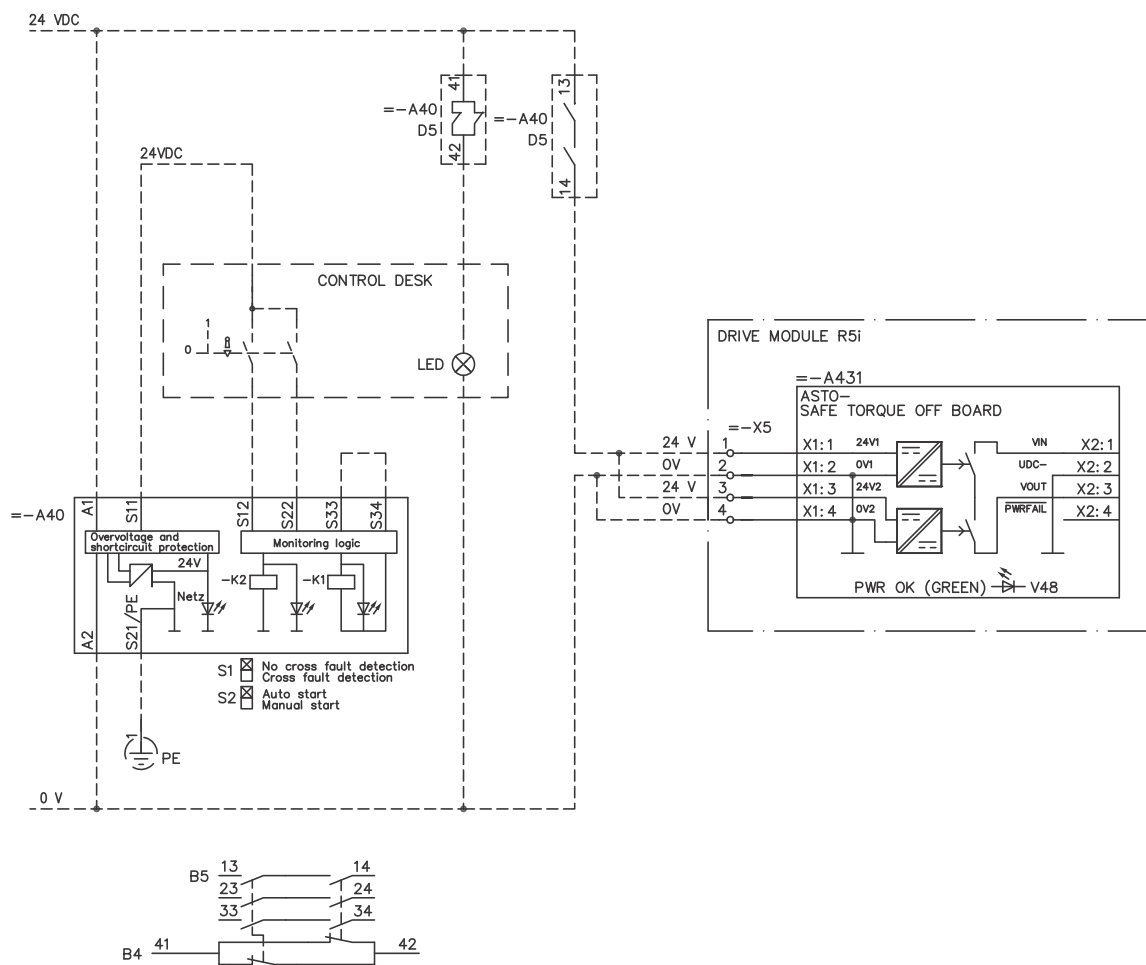

20 Installation

Frame size R7i

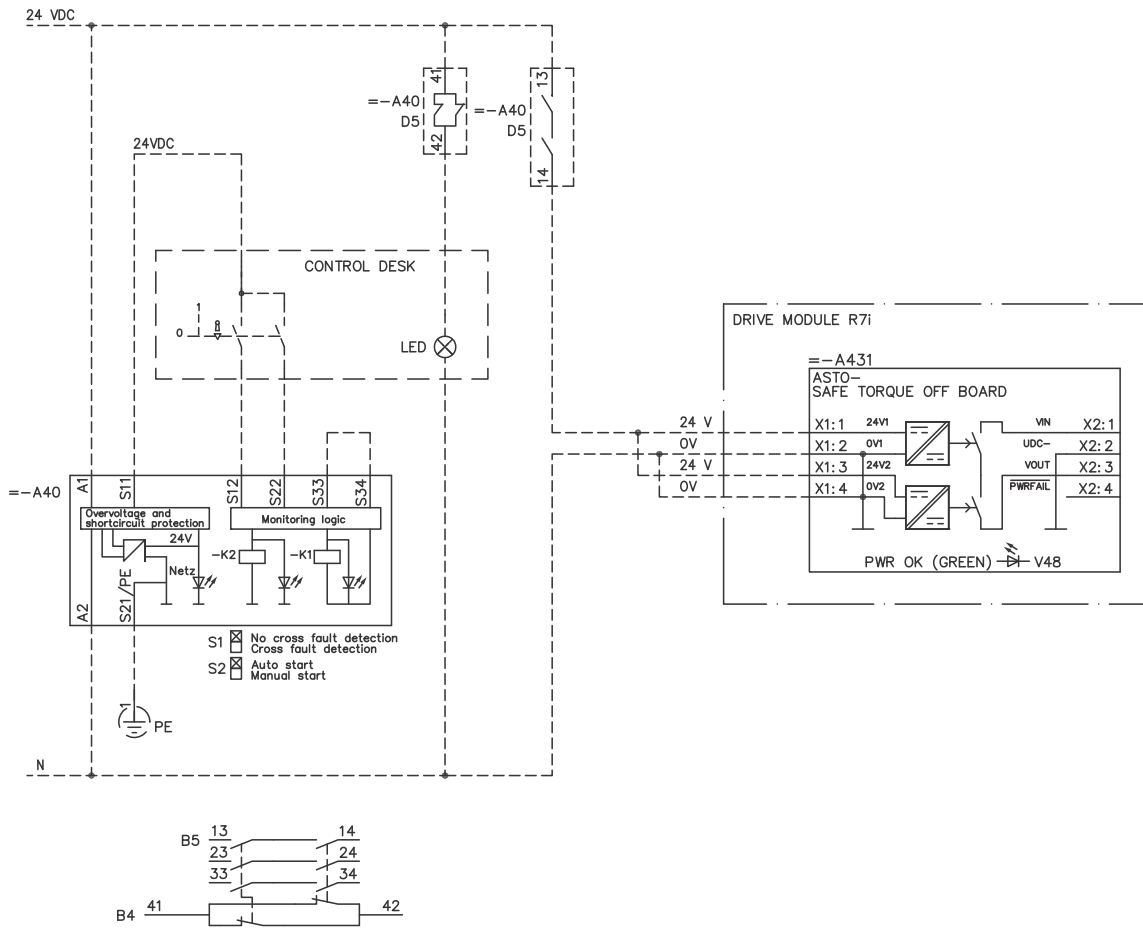

3AUA0000071142

Frame size R8i

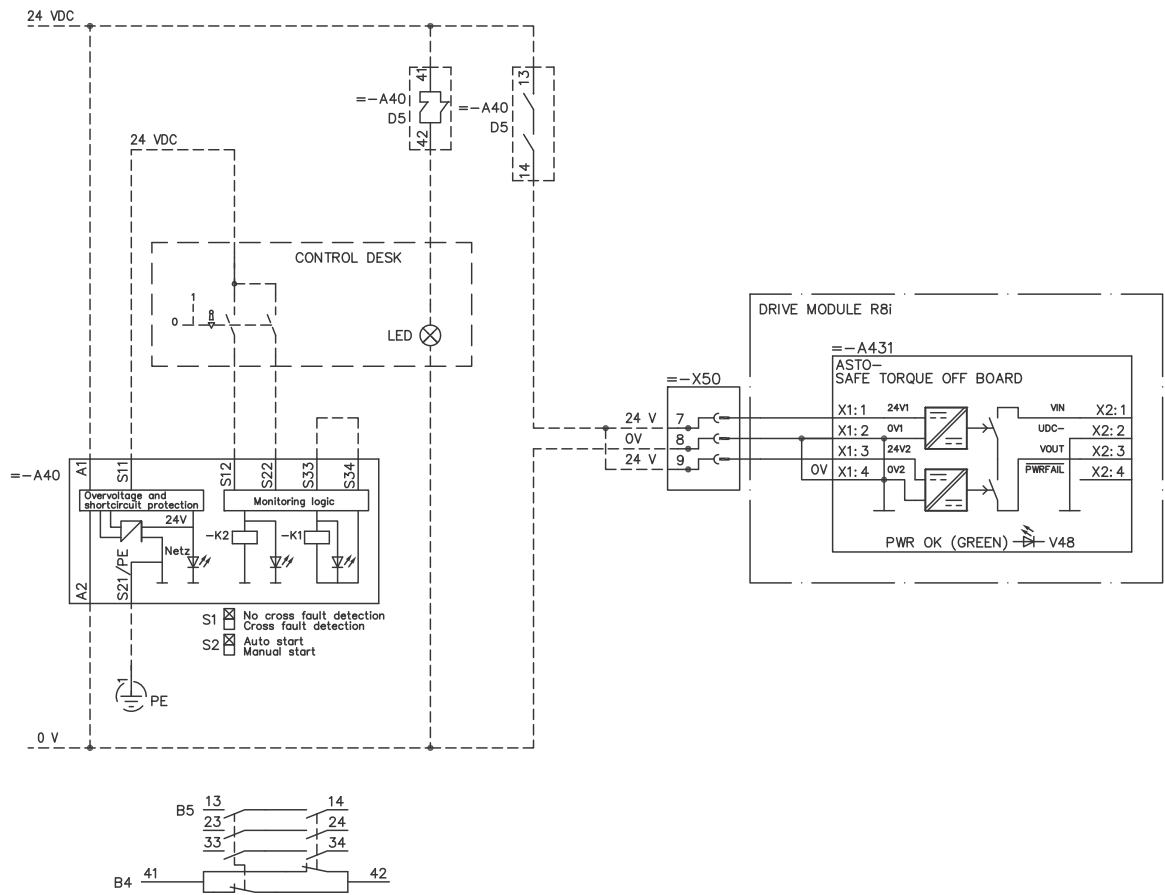

Connecting several drive modules to one safety relay

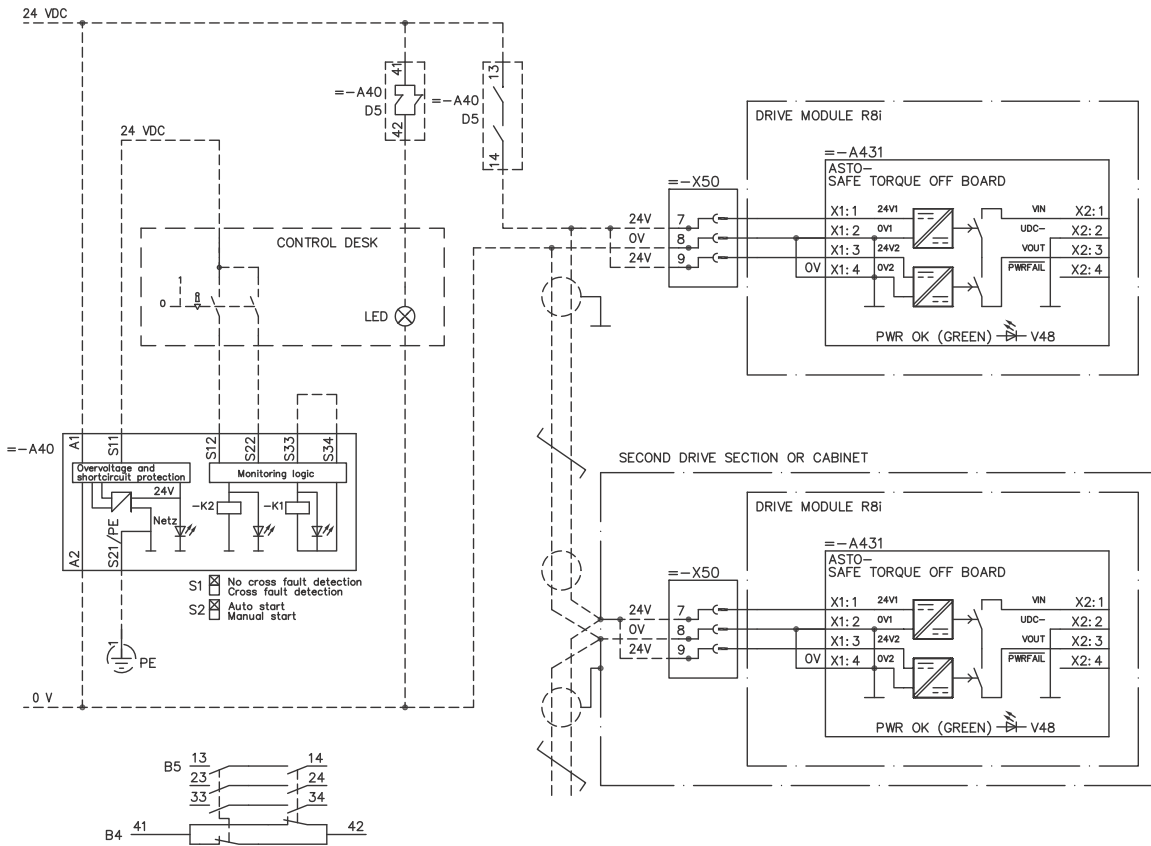

3AUA0000096632

4

Start-up and validation

Validating the operation of a safety function

EN IEC 62061 and EN ISO 13849 require that the final assembler of the machine validates the operation of the safety function with an acceptance test. The acceptance tests for the standard safety functions of the drive are described in chapter *Start-up* of the drive Hardware (or User's) manual. The tests for the optional safety functions are described in the appropriate option manuals.

The acceptance test must be performed:

- at initial start-up of the safety function
- after any changes related to the safety function (wiring, components, settings, etc.)
- after any changes related to the circuit boards of the drive
- after any maintenance work related to the safety function.

■ Authorized person

The acceptance test of the safety function must be carried out by an authorized person with expertise and knowledge of the safety function. The test must be documented and signed by the authorized person.

■ Acceptance test reports

Signed acceptance test reports must be stored in the logbook of the machine. The report shall include documentation of start-up activities and test results, references to failure reports and resolution of failures. Any new acceptance tests performed due to changes or maintenance shall be logged into the logbook.



Start-up checklist

	Action
<input type="checkbox"/>	Ensure that the drive can be run and stopped freely during the commissioning.
<input type="checkbox"/>	Stop the drive (if running), switch the input power off and isolate the drive from the power line by a disconnecter.
<input type="checkbox"/>	Check the STO circuit connections against the circuit diagram.
<input type="checkbox"/>	Close the disconnecter and switch the power on.
<input type="checkbox"/>	Test the operation of the STO function when the motor is stopped: <ul style="list-style-type: none"> • Give a stop command for the drive (if running) and wait until the motor shaft is at standstill. • Activate the STO circuit and give a start command for the drive. • Ensure that the motor stays at standstill and the drive operates as described in section Operation of the STO function and its diagnostics function on page 9. • Deactivate the STO circuit.
<input type="checkbox"/>	Restart the drive and check that the motor runs normally.
<input type="checkbox"/>	Test the operation of the STO function when the motor is running: <ul style="list-style-type: none"> • Start the drive and ensure the motor is running. • Activate the STO circuit. • Ensure that the motor stops and the drive trips. • Reset the fault and try to start the drive. • Ensure that the motor stays at standstill and the drive operates as described in section Operation of the STO function and its diagnostics function on page 9. • Deactivate the STO circuit.
<input type="checkbox"/>	Restart the drive and check that the motor runs normally.
<input type="checkbox"/>	The STO function is safe and accepted to operate.
<input type="checkbox"/>	Document and sign the acceptance test report which verifies that the safety function is safe and accepted to operation.



5

Maintenance and fault tracing

Maintenance

Include the STO operation test described in chapter [Start-up and validation](#) to the routine maintenance program of the machinery that the drive runs. If the circuit boards or wire sets are replaced inside the module, test the functioning of the safety circuit according to [Start-up checklist](#). If you detect any failure in safety functions, including STO, contact your local ABB representative.

The STO function or STO input terminals do not need any maintenance. Maintain the drive according to the instructions given in the drive hardware manual.

Warning messages generated by the drive

Warning	Cause	What to do
START INHIBI	Safe torque off function has been activated while the drive was stopped.	Close Safe torque off function switch. If the switch is closed and the warning is still active, check power supply at ASTO board input terminals. Replace ASTO board.

Fault messages generated by the drive

Fault	Cause	What to do
GD DISABLED X	ASTO board power supply of parallel-connected R8i inverter module has been switched off during run. X (1...12) refers to inverter module number.	Check Safe torque off function circuit of this module (X). Replace ASTO board of R8i inverter module.
START INHIBI	Safe torque off has been activated during motor run or motor start command has been given when Safe torque off is active.	Close Safe torque off function switch. If the switch is closed and the fault is still active, check power supply at ASTO board input terminals. Replace ASTO board.



Technical data

STO components

■ ASTO-11/21 board

ASTO-11 and 21 board	
Supply voltage range	+24 V DC +/- 10%
Current consumption	40 mA (20 mA/channel)
Supply cable	A single-shielded twisted pair
Maximum cable length	300 m
Conductor min. cross section	0.5 mm ² , 20 AWG
Ambient temperature	0...50 °C
Relative humidity	Max. 90%, no condensation allowed
Altitude in operation	0...2000 m
ASTO-11 board	
Dimensions	167 x 128 x 52 mm (height x weight x depth)
Weight	0.75 kg
Degree of protection	IP20

Note: Supply from semiconductor safety output with test pulse is not allowed.

ASTO board according to frame size of the module

Frame size	ASTO-11/21 board
R2i...R5i	ASTO-11
R2...R6	ASTO-11
R7i...R8i	ASTO-21
R7...R8	ASTO-21

Note: In frame sizes R2...R6 of the ACS800-01, -04, -11 and -31 drives the ASTO board is ASTO-11 with enclosure. In frames R7...R8 and R2i...R8i the ASTO board is inside the drive module.

Dimensions of the ASTO board with enclosure

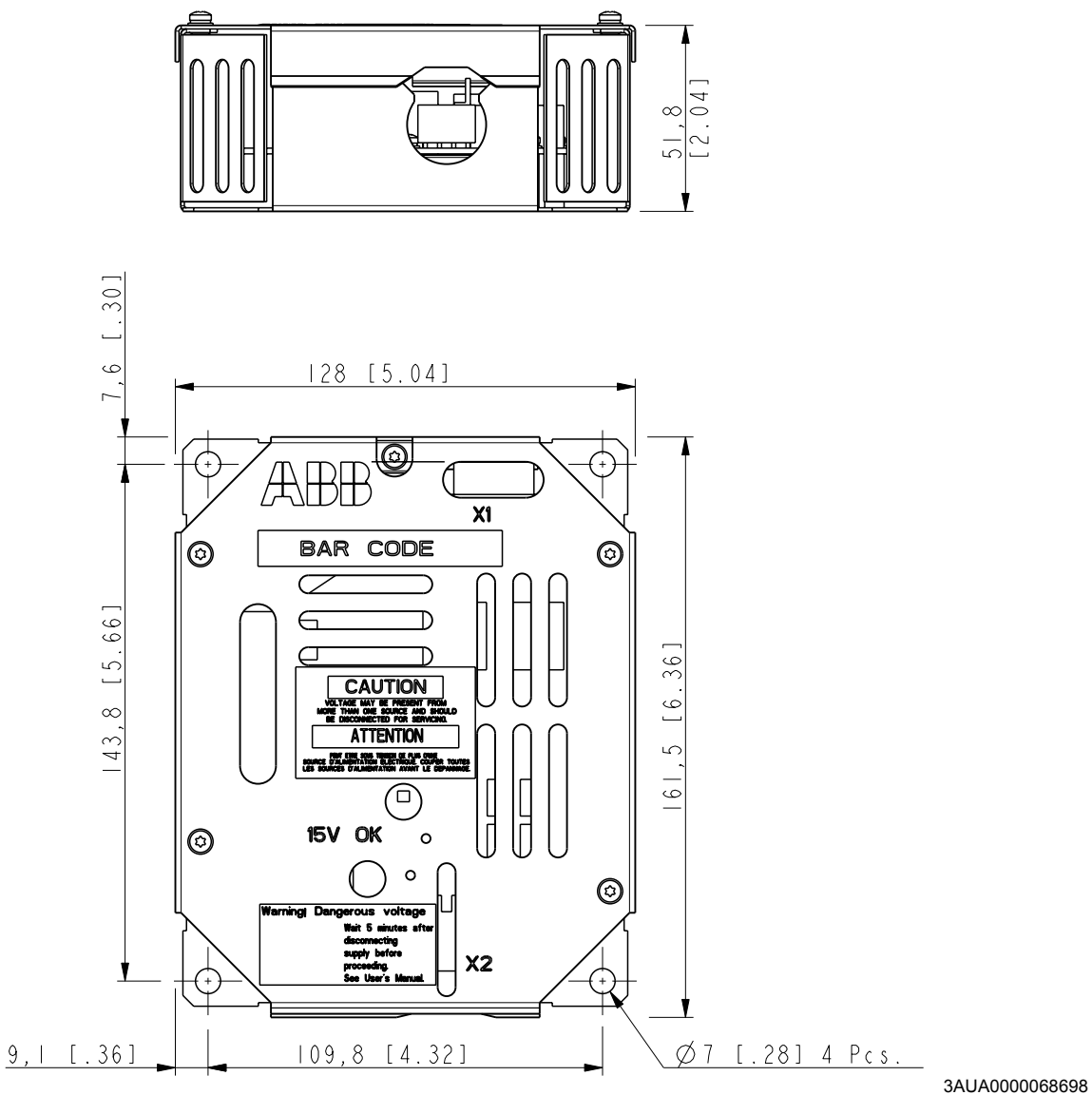

■ STO safety relay type

General requirements	IEC 61508 and/or EN/ISO 13849-1
Example 1	Simple SIL3 approved safety relay
Type and manufacturer	DOLD LG 5925.48/60 AC/DC 24 V
Approvals	SILCL 3 according to EN 62061 and PL e according to EN ISO 13849-1
Example 2	Programmable safety logic
Type and manufacturer	PNOZ Multi M1p by Pilz
Approvals	IEC 61508, SIL3; and EN ISO 13849-1, PL e

■ Push-button to be used with emergency stop

Type	A push-button operated switch with a palm or mushroom head type. Actuators of emergency stop devices are colored red.
Example	New Elfin 020PTFASRK+020GE02

■ STO switch to be used with Prevention of unexpected start-up function implemented with STO

Type	A lockable selector switch with a reliable and unambiguous indication of positions.
Example	Kraus & Naimer DH11 A291-600, FT22-V+S0V845/A11/D11

STO data related to safety standards (safety relay not included)

Data related to safety standards IEC 61508, EN 61800-5-2, EN/ISO 13849-1 and EN 62061 are listed below according to the frame sizes. Data apply to both air-cooled and liquid-cooled modules.

■ Frame size R2/R2i

SILCL, SIL	2	Category	2	Lifetime	20 years
PL	d	DC	98.35%	HFT	0
MTTF_d	462.3 years	SFF	99.62%	Proof test interval T1¹⁾	20 years
PFH_d	5.81E-09 1/h (5.81 FIT)	CCF	65 points	PFD¹⁾	5.10E-04

■ Frame size R3/R3i

SILCL, SIL	2	Category	2	Lifetime	20 years
PL	d	DC	98.49%	HFT	0
MTTF_d	465.2 years	SFF	99.66%	Proof test interval T1¹⁾	20 years
PFH_d	5.06E-09 1/h (5.06 FIT)	CCF	65 points	PFD¹⁾	4.44E-04

■ Frame size R4/R4i

SILCL, SIL	2	Category	2	Lifetime	20 years
PL	d	DC	96.74%	HFT	0
MTTF_d	430.4 years	SFF	99.26%	Proof test interval T1¹⁾	20 years
PFH_d	15.0E-09 1/h (15.0 FIT)	CCF	65 points	PFD¹⁾	1.31E-03

■ Frame size R5/R5i

SILCL, SIL	2	Category	2	Lifetime	20 years
PL	d	DC	97.34%	HFT	0
MTTF_d	442.0 years	SFF	99.39%	Proof test interval T1¹⁾	20 years
PFH_d	11.5E-09 1/h (11.5 FIT)	CCF	65 points	PFD¹⁾	1.01E-03

■ Frame size R6

SILCL, SIL	2	Category	2	Lifetime	20 years
PL	d	DC	98.28%	HFT	0
MTTF_d	460.8 years	SFF	99.61%	Proof test interval T1¹⁾	20 years
PFH_d	6.23E-09 1/h (6.23 FIT)	CCF	65 points	PFD¹⁾	5.46E-04

■ Frame size R7/R7i/R8/R8i

SILCL, SIL	2	Category	2	Lifetime	20 years
PL	d	DC	98.40%	HFT	0
MTTF_d	467.3 years	SFF	99.72%	Proof test interval T1¹⁾	20 years
PFH_d	3.94E-09 1/h (3.94 FIT)	CCF	65 points	PFD¹⁾	3.45E-04

■ Multiples of frame size R8i

Above values for *Frame size R7/R7i/R8/R8i* apply for the multiples of frame size R8i, except for values of MTTF_d, PFH_d and PFD. These values are listed below.

Frame size 2×R8i

MTTF_d	233.6 years	PFH_d	7.87E-09 1/h (7.87 FIT)	PFD¹⁾	6.90E-04
-------------------------	-------------	------------------------	----------------------------	-------------------------	----------

Frame size 3×R8i

MTTF_d	155.8 years	PFH_d	11.8E-09 1/h (11.8 FIT)	PFD¹⁾	1.04E-03
-------------------------	-------------	------------------------	----------------------------	-------------------------	----------

Frame size 4×R8i

MTTF_d	116.8 years	PFH_d	15.7E-09 1/h (15.7 FIT)	PFD¹⁾	1.38E-03
-------------------------	-------------	------------------------	----------------------------	-------------------------	----------

Frame size 5×R8i

MTTF_d	93.5 years	PFH_d	19.7E-09 1/h (19.7 FIT)	PFD¹⁾	1.73E-03
-------------------------	------------	------------------------	----------------------------	-------------------------	----------

Frame size 6×R8i

MTTF_d	77.9 years	PFH_d	23.6E-09 1/h (23.6 FIT)	PFD¹⁾	2.07E-03
-------------------------	------------	------------------------	----------------------------	-------------------------	----------

Frame size 7×R8i

MTTF_d	66.8 years	PFH_d	27.6E-09 1/h (27.6 FIT)	PFD¹⁾	2.42E-03
-------------------------	------------	------------------------	----------------------------	-------------------------	----------

Frame size 8×R8i

MTTF_d	58.4 years	PFH_d	31.5E-09 1/h (31.5 FIT)	PFD¹⁾	2.76E-03
-------------------------	------------	------------------------	----------------------------	-------------------------	----------

Frame size 9×R8i

MTTF_d	51.9 years	PFH_d	35.4E-09 1/h (35.4 FIT)	PFD¹⁾	3.11E-03
-------------------------	------------	------------------------	----------------------------	-------------------------	----------

Frame size 10×R8i

MTTF_d	46.7 years	PFH_d	39.4E-09 1/h (39.4 FIT)	PFD¹⁾	3.45E-03
-------------------------	------------	------------------------	----------------------------	-------------------------	----------

Frame size 11×R8i

MTTF_d	42.5 years	PFH_d	43.3E-09 1/h (43.3 FIT)	PFD¹⁾	3.80E-03
-------------------------	------------	------------------------	----------------------------	-------------------------	----------

Frame size 12×R8i

MTTF_d	38.9 years	PFH_d	47.3E-09 1/h (47.3 FIT)	PFD¹⁾	4.14E-03
-------------------------	------------	------------------------	----------------------------	-------------------------	----------

¹⁾ **Note:** T1 is 20 years in high demand or continuous mode of operation, and PFH_d is calculated according to this T1 value. T1 is 2 years in low demand mode of operation, and PFD is calculated according to this T1 value.

■ Abbreviations

Abbreviation	Reference	Description
ASTO		Safe torque off board
CCF	EN/ISO 13849-1	Common Cause Failure (%)
DC	EN/ISO 13849-1	Diagnostic Coverage
FIT	IEC 61508	Failure In Time: 1E-9 hours
HFT	IEC 61508	Hardware Fault Tolerance
MTTF _d	EN/ISO 13849-1	Mean Time To dangerous Failure: (The total number of life units) / (the number of dangerous, undetected failures) during a particular measurement interval under stated conditions
PFD	IEC 61508	Probability of Dangerous Failure on Demand
PFH _d	IEC 61508	Probability of Dangerous Failures per Hour
PL	EN/ISO 13849-1	Performance Level: Corresponds SIL, Levels a-e
SFF	IEC 61508	Safe Failure Fraction (%)
SIL	IEC 61508	Safety Integrity Level
STO	EN 61800-5-2	Safe torque off

TÜV certificate



Certificate

No. SLA-0232/08-1, Ver. 3

TÜV NORD Systems GmbH & Co. KG hereby certifies

ABB Oy
 Hiomotie 13
 FI-00381 Helsinki
 Finland

that the realization of the safety function "Safe Torque Off" (STO) in the ABB product series

ACS800 and ACS800LC Frames R2(i)-R8(i)

is capable for safety related applications up to SIL 2, SILcl 2 and PL d and meets the requirements listed in the following standards

- IEC 61508 part 1:1998; part 2:2000; capable up to SIL 2
- IEC 61800-5-2:2007; capable up to SIL 2
- ISO 13849-1:2008; capable up to PL d (category 2)
- IEC 62061:2005; capable up to SIL_{CL}2
- IEC 61511: 2004; capable up to SIL2

The voluntary certification is based on the report No. SLA-0232/08TB-1 in the valid version.

This certificate entitles the holder to use the pictured Safety Approved mark.

Expiry date: 2015-02-17
 Reference No.: G.SCC.DL.03.004.09.SLA

Gerhard M. Rieger
 Augsburg, 2012-01-27



Declarations of Conformity



Declaration of Conformity

(According to Machinery Directive 2006/42/EC)

Manufacturer: ABB Oy, Drives
Address: Hiomotie 13, P.O Box 184, FIN-00381 Helsinki, Finland.

hereby declares that the products:

ACS800-01/-U1 single drives, frame sizes R2-R6

Product safety function

Safe torque-off (+Q967)

Fulfills all the relevant safety component requirements of EC Machinery Directive 2006/42/EC, when the listed safety function is used for safety component functionality.

The following harmonized standards below were used:

EN 61800-5-2: 2007	<i>Adjustable speed electrical power drive systems – Part 5-2: Safety requirements - Functional</i>
EN 62061: 2005/ AC: 2010	<i>Safety of machinery – Functional safety of safety-related electrical, electronic and programmable electronic control systems</i>
EN ISO 13849-1: 2008/ AC: 2009	<i>Safety of machinery – Safety-related parts of control systems. Part 1: General requirements</i>
EN ISO 13849-2: 2008	<i>Safety of machinery – Safety-related parts of the control systems. Part 2: Validation</i>
EN 60204-1: 2006/ AC: 2010	<i>Safety of machinery – Electrical equipment of machines – Part 1: General requirements</i>

Other used standards:

IEC 61508 ed. 1	Functional safety of electrical / electronic / programmable electronic safety-related systems
-----------------	---

The products referred in this Declaration of Conformity fulfil the relevant provisions of the Low Voltage Directive 2006/95/EC and EMC Directive 2004/108/EC. Declaration of conformity according to these directives is available from the manufacturer.

Person authorized to compile the technical file:

Name: Risto Mynttinen
Address: P.O. Box 184, FIN-00381 Helsinki, Finland

Helsinki, 20 September 2012

Mika Kulju

Vice President
ABB Oy



Declaration of Conformity

(According to Machinery Directive 2006/42/EC)

Manufacturer: ABB Oy, Drives
Address: Hiomotie 13, P.O Box 184, FIN-00381 Helsinki, Finland.

hereby declares that the products:

ACS800-02/-U2 single drives, frame sizes R7-R8

Product safety function

Safe torque-off (+Q967)

Fulfils all the relevant safety component requirements of EC Machinery Directive 2006/42/EC, when the listed safety function is used for safety component functionality.

The following harmonized standards below were used:

EN 61800-5-2: 2007	<i>Adjustable speed electrical power drive systems – Part 5-2: Safety requirements - Functional</i>
EN 62061: 2005/ AC: 2010	<i>Safety of machinery – Functional safety of safety-related electrical, electronic and programmable electronic control systems</i>
EN ISO 13849-1: 2008/ AC: 2009	<i>Safety of machinery – Safety-related parts of control systems. Part 1: General requirements</i>
EN ISO 13849-2: 2008	<i>Safety of machinery – Safety-related parts of the control systems. Part 2: Validation</i>
EN 60204-1: 2006/ AC: 2010	<i>Safety of machinery – Electrical equipment of machines – Part 1: General requirements</i>

Other used standards:

IEC 61508 ed. 1	Functional safety of electrical / electronic / programmable electronic safety-related systems
-----------------	---

The products referred in this Declaration of Conformity fulfil the relevant provisions of the Low Voltage Directive 2006/95/EC and EMC Directive 2004/108/EC. Declaration of conformity according to these directives is available from the manufacturer.

Person authorized to compile the technical file:

Name: Risto Mynttinen
Address: P.O. Box 184, FIN-00381 Helsinki, Finland

Helsinki, 20 September 2012

Mika Kulju

Vice President
ABB Oy



Declaration of Conformity

(According to Machinery Directive 2006/42/EC)

Manufacturer: ABB Oy, Drives
Address: Hiomotie 13, P.O Box 184, FIN-00381 Helsinki, Finland.

hereby declares that the products:

ACS800-04 (nxD4 + nxR8i), ACS800-14, ACS800-104

ACS800-04LC, ACS800-104LC

Product safety function

Safe Torque Off (option code +Q967)

Fulfils all the relevant safety component requirements of EC Machinery Directive 2006/42/EC, when the listed safety function is used for safety component functionality.

The following harmonized standards below were used:

EN 61800-5-2: 2007	<i>Adjustable speed electrical power drive systems – Part 5-2: Safety requirements - Functional</i>
EN 62061: 2005/ AC: 2010	<i>Safety of machinery – Functional safety of safety-related electrical, electronic and programmable electronic control systems</i>
EN ISO 13849-1: 2008/ AC: 2009	<i>Safety of machinery – Safety-related parts of control systems. Part 1: General requirements</i>
EN ISO 13849-2: 2008	<i>Safety of machinery – Safety-related parts of the control systems. Part 2: Validation</i>
EN 60204-1: 2006/ AC: 2010	<i>Safety of machinery – Electrical equipment of machines – Part 1: General requirements</i>

Other used standards:

IEC 61508 ed. 1	Functional safety of electrical / electronic / programmable electronic safety-related systems
-----------------	---

The products referred in this Declaration of Conformity fulfil the relevant provisions of the Low Voltage Directive 2006/95/EC and EMC Directive 2004/108/EC. Declaration of conformity according to these directives is available from the manufacturer.



Declaration of Conformity

(According to Machinery Directive 2006/42/EC)

Person authorized to compile the technical file:

Name: Ilpo Kangas
Address: P.O. Box 184, FIN-00381 Helsinki, Finland

Helsinki, 02 Jan 2013

A handwritten signature in blue ink, appearing to read 'Peter Lindgren', is written over a horizontal line.

Peter Lindgren
Vice President
ABB Oy



Declaration of Conformity

(According to Machinery Directive 2006/42/EC)

Manufacturer: ABB Oy, Drives
Address: Hiomotie 13, P.O Box 184, FIN-00381 Helsinki, Finland.

hereby declares that the products:

ACS800-04/-U4 drive modules, frame sizes R2-R8

ACS800-04M drive modules, frame sizes R7-R8

Product safety function

Safe torque-off (+Q967)

Fulfils all the relevant safety component requirements of EC Machinery Directive 2006/42/EC, when the listed safety function is used for safety component functionality.

The following harmonized standards below were used:

EN 61800-5-2: 2007	<i>Adjustable speed electrical power drive systems – Part 5-2: Safety requirements - Functional</i>
EN 62061: 2005/ AC: 2010	<i>Safety of machinery – Functional safety of safety-related electrical, electronic and programmable electronic control systems</i>
EN ISO 13849-1: 2008/ AC: 2009	<i>Safety of machinery – Safety-related parts of control systems. Part 1: General requirements</i>
EN ISO 13849-2: 2008	<i>Safety of machinery – Safety-related parts of the control systems. Part 2: Validation</i>
EN 60204-1: 2006/ AC: 2010	<i>Safety of machinery – Electrical equipment of machines – Part 1: General requirements</i>

Other used standards:

IEC 61508 ed. 1	Functional safety of electrical / electronic / programmable electronic safety-related systems
-----------------	---

The products referred in this Declaration of Conformity fulfil the relevant provisions of the Low Voltage Directive 2006/95/EC and EMC Directive 2004/108/EC. Declaration of conformity according to these directives is available from the manufacturer.



Declaration of Conformity

(According to Machinery Directive 2006/42/EC)

Person authorized to compile the technical file:

Name: Risto Mynttinen
Address: P.O. Box 184, FIN-00381 Helsinki, Finland

Helsinki, 20 September 2012

A handwritten signature in blue ink, appearing to read 'Mika Kulju'.

Mika Kulju
Vice President
ABB Oy



Declaration of Conformity

(According to Machinery Directive 2006/42/EC)

Manufacturer: ABB Oy, Drives
Address: Hiomotie 13, P.O Box 184, FIN-00381 Helsinki, Finland.

hereby declares that the products:

ACS800-11/-U11 single drives, frame sizes R5-R6

Product safety function

Safe torque-off (+Q967)

Fulfils all the relevant safety component requirements of EC Machinery Directive 2006/42/EC, when the listed safety function is used for safety component functionality.

The following harmonized standards below were used:

EN 61800-5-2: 2007	<i>Adjustable speed electrical power drive systems – Part 5-2: Safety requirements - Functional</i>
EN 62061: 2005/ AC: 2010	<i>Safety of machinery – Functional safety of safety-related electrical, electronic and programmable electronic control systems</i>
EN ISO 13849-1: 2008/ AC: 2009	<i>Safety of machinery – Safety-related parts of control systems. Part 1: General requirements</i>
EN ISO 13849-2: 2008	<i>Safety of machinery – Safety-related parts of the control systems. Part 2: Validation</i>
EN 60204-1: 2006/ AC: 2010	<i>Safety of machinery – Electrical equipment of machines – Part 1: General requirements</i>

Other used standards:

IEC 61508 ed. 1	Functional safety of electrical / electronic / programmable electronic safety-related systems
-----------------	---

The products referred in this Declaration of Conformity fulfil the relevant provisions of the Low Voltage Directive 2006/95/EC and EMC Directive 2004/108/EC. Declaration of conformity according to these directives is available from the manufacturer.

Person authorized to compile the technical file:

Name: Risto Mynttinen
Address: P.O. Box 184, FIN-00381 Helsinki, Finland

Helsinki, 20 September 2012

Mika Kulju

Vice President
ABB Oy



Declaration of Conformity

(According to Machinery Directive 2006/42/EC)

Manufacturer: ABB Oy, Drives
Address: Hiomotie 13, P.O Box 184, FIN-00381 Helsinki, Finland.

hereby declares that the products:

ACS800-31/-U31 single drives, frame sizes R5-R6

Product safety function

Safe torque-off (+Q967)

Fulfills all the relevant safety component requirements of EC Machinery Directive 2006/42/EC, when the listed safety function is used for safety component functionality.

The following harmonized standards below were used:

EN 61800-5-2: 2007	<i>Adjustable speed electrical power drive systems – Part 5-2: Safety requirements - Functional</i>
EN 62061: 2005/ AC: 2010	<i>Safety of machinery – Functional safety of safety-related electrical, electronic and programmable electronic control systems</i>
EN ISO 13849-1: 2008/ AC: 2009	<i>Safety of machinery – Safety-related parts of control systems. Part 1: General requirements</i>
EN ISO 13849-2: 2008	<i>Safety of machinery – Safety-related parts of the control systems. Part 2: Validation</i>
EN 60204-1: 2006/ AC: 2010	<i>Safety of machinery – Electrical equipment of machines – Part 1: General requirements</i>

Other used standards:

IEC 61508 ed. 1	Functional safety of electrical / electronic / programmable electronic safety-related systems
-----------------	---

The products referred in this Declaration of Conformity fulfil the relevant provisions of the Low Voltage Directive 2006/95/EC and EMC Directive 2004/108/EC. Declaration of conformity according to these directives is available from the manufacturer.

Person authorized to compile the technical file:

Name: Risto Mynttinen
Address: P.O. Box 184, FIN-00381 Helsinki, Finland

Helsinki, 20 September 2012

Mika Kulju
Vice President
ABB Oy

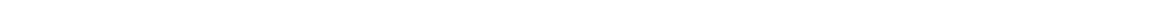

Further information

Product and service inquiries

Address any inquiries about the product to your local ABB representative, quoting the type designation and serial number of the unit in question. A listing of ABB sales, support and service contacts can be found by navigating to www.abb.com/drives and selecting *Sales, Support and Service network*.

Product training

For information on ABB product training, navigate to www.abb.com/drives and select *Training courses*.

Providing feedback on ABB Drives manuals

Your comments on our manuals are welcome. Go to www.abb.com/drives and select *Document Library – Manuals feedback form (LV AC drives)*.

Document library on the Internet

You can find manuals and other product documents in PDF format on the Internet. Go to www.abb.com/drives and select *Document Library*. You can browse the library or enter selection criteria, for example a document code, in the search field.

Contact us

www.abb.com/drives

www.abb.com/drivespartners

3AUJA0000063373 Rev G (EN) 2013-02-04