

ACS850

Quick Installation Guide ACS850-04 Drive Modules (55...200 kW, 60...200 hp)



English.....	3
Dansk	9
Deutsch	15
Español	21
Suomi	27
Français.....	33
Italiano.....	39
Nederlands	45
Português (Brasil)	51
Русский.....	57
Svenska.....	63
Türkçe	69
中文.....	75

3AUA0000045488 Rev E

Effective: 2012-08-16

© 2012 ABB Oy. All rights reserved.



ACS850 drive manuals

DRIVE HARDWARE MANUALS *

ACS850-04 Drive Modules (0.37 to 45 kW) Hardware Manual –
3AUA0000045496 (English)

ACS850-04 Drive Modules (55 to 200 kW, 60 to 200 hp) Hardware Manual –
3AUA0000045487 (English)

ACS850-04 Drive Modules (200 to 500 kW, 250 to 600 hp) Hardware Manual –
3AUA0000026234 (English)

ACS850-04 Drive Modules (160 to 560 kW, 200 to 700 hp) Hardware Manual –
3AUA0000081249 (English)

DRIVE FIRMWARE MANUALS **

ACS850 Standard Control Program Firmware Manual –
3AUA0000045497 (English)

ACS850 Crane Control Program (+N5050 +N3050) Supplement –
3AUA0000081708 (English)

ACS850-04 drives with SynRM motors (option +N7502) Supplement –
3AUA0000123521 (English)

OPTION MANUALS ***

Manuals for I/O Extension Modules, Fieldbus Adapters etc.

*The delivery includes a multilingual quick installation guide.

**The delivery includes a multilingual quick start-up guide.

***Included in the delivery with appropriate option device.

Quick installation guide – ACS850-04

About this guide

This guide contains the very basic information about the mechanical and electrical installation of the ACS850-04 drive module (55 to 200 kW). For complete documentation see *ACS850-04 Drive Modules (55...200 kW, 60...200 hp) Hardware Manual* (code: 3AUA0000045487 [English]).

Safety instructions



WARNING! All electrical installation and maintenance work on the drive must be carried out by qualified electricians only.

Never work on the drive, the braking chopper circuit, the motor cable or the motor when input power is applied to the drive. Always ensure by measuring that no voltage is actually present.

A rotating permanent magnet motor can generate a dangerous voltage. Lock the motor shaft mechanically before connecting a permanent magnet motor to the drive, and before doing any work on a drive system connected to a permanent magnet motor.

Mechanical installation



WARNING! If the drive is to be connected to an IT power system (i.e. ungrounded, or high-resistance-grounded [over 30 ohms] power system), the internal EMC filtering of the drive must be disconnected. This should be done before the drive is mechanically installed. Refer to the *Hardware Manual* for detailed instructions.

Fasten the drive module onto the wall with four screws.

Installing the power cables

Connection diagram

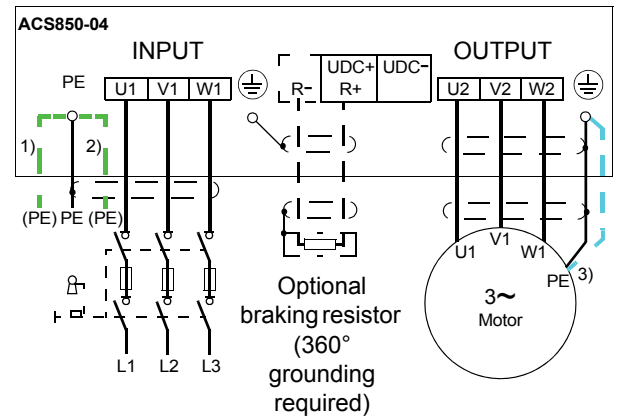

Notes:

- Do not use a non-shielded or asymmetrically-constructed motor cable. It is recommended to use a shielded cable also as an supply (input) cable.
- If shielded supply (input) cable is used, and the conductivity of the shield is less than 50% of the conductivity of a phase conductor, use a cable with a ground conductor (1) or a separate PE cable (2).
- For motor cabling, use a separate ground cable (3) if the conductivity of the cable shield is less than 50% of the conductivity of a phase conductor and the cable has no symmetrical ground conductors.

If there is a symmetrically-constructed ground conductor in the motor cable in addition to the conductive shield, connect it to the ground connectors at both the drive and motor ends.

Connection procedure

Cabling examples are presented below. Tightening torques are presented on page 5 and at appropriate points in the text.

- Remove the plastic shroud covering the main terminals. Lift up with a screw driver from the corner.
- Connect the twisted shields of the power cables and separate grounding conductors to the grounding terminals of the drive module.
- Connect the phase conductors of the supply cable to the U1, V1 and W1 terminals, and the phase conductors of the motor cable to the U2, V2 and W2 terminals. The recommended stripping length is 16 mm (0.63") for frame size E0 and 28 mm (1.1") for frame size E.
- Secure the cables mechanically outside the drive module.
- Cut holes for the installed cables into the clear plastic shroud to accommodate the power cables. Press the shroud onto the terminals.
- Connect the other ends of the power cables. To ensure safety, pay special attention to connection of the grounding conductors.

Frame size E: Cable lug installation (16 to 70 mm² [AWG6 to AWG2/0] cables)

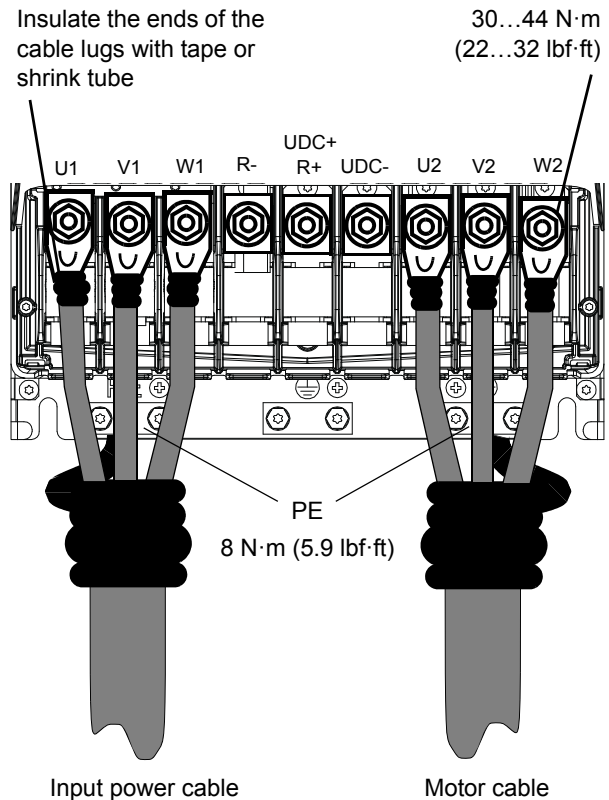

Cabling examples

Frame size E0: Screw terminal installation

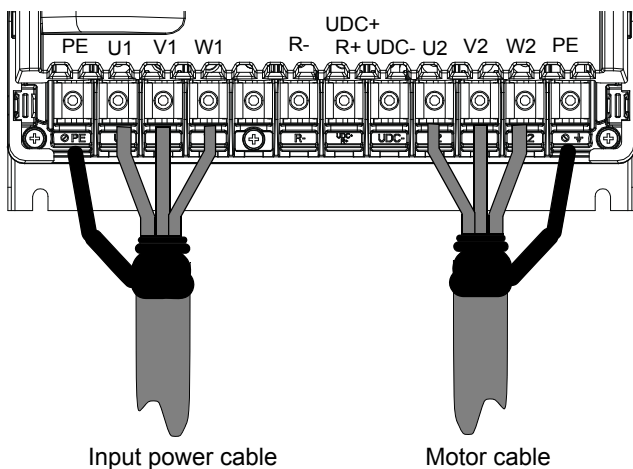

Frame size E: Screw terminal installation (95 to 240 mm² [AWG3/0 to 500MCM] cables)

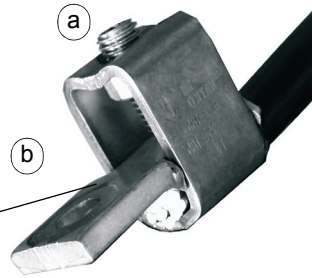
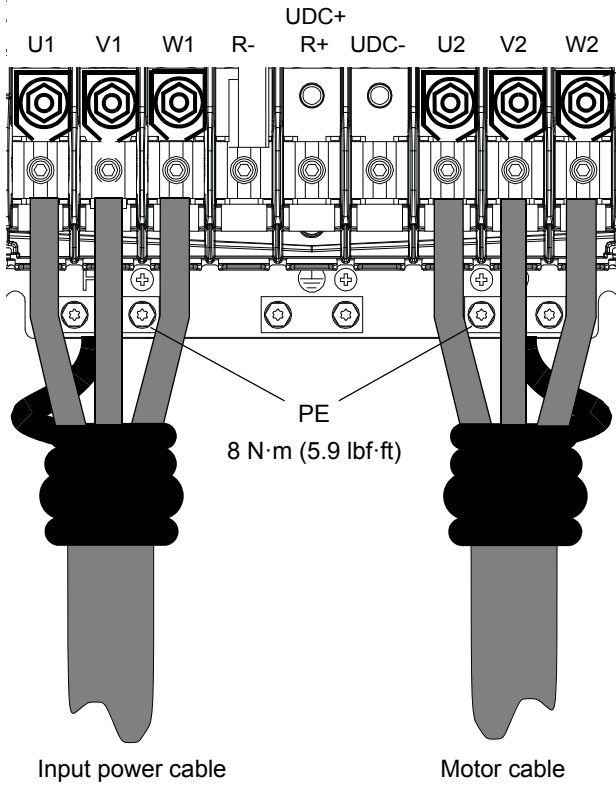

- a. Connect the cable to the terminal. Tighten the Allen screw to 20...40 N·m (15...30 lbf·ft).
- b. Connect the terminal to the drive. Tighten to 30...44 N·m (22...32 lbf·ft).



WARNING! If the wire size is less than 95 mm² (3/0 AWG), a crimp lug must be used. A cable of wire size less than 95 mm² (3/0 AWG) connected to this terminal will loosen and may damage the drive.

Wire sizes accepted by power terminals

Drive type ACS850-04...	Wire size
-103A-5, -144A-5	6 ... 70 mm ²
-166A-5...-290A-5	95 ... 240 mm ²

Tightening torques

Drive type ACS850-04...	Power terminals	PE
	N·m (lbf·ft)	N·m (lbf·ft)
-103A-5, -144A-5	15 (11)	15 (11)
-166A-5...-290A-5	Cable lug installation 30...44 (22...32)	8 (5.9)
	Allen screw 20...40 (15...30) Screw terminal installation 30...44 (22...32)	8 (5.9)

Installing the control cables

Default I/O connection diagram

Notes:

[Default setting with ACS850 standard control program (Factory macro).

*Total maximum current: 200 mA

The wiring shown is for demonstrative purposes only.

For jumper settings, see text.

Wire sizes and tightening torques:

XPOW, XRO1, XRO2, XRO3, XD24:
0.5 ... 2.5 mm² (24...12 AWG). Torque: 0.5 N·m (5 lbf·in)

XDI, XDIO, XAI, XAO, XD2D, XSTO:
0.5 ... 1.5 mm² (28...14 AWG). Torque: 0.3 N·m (3 lbf·in)

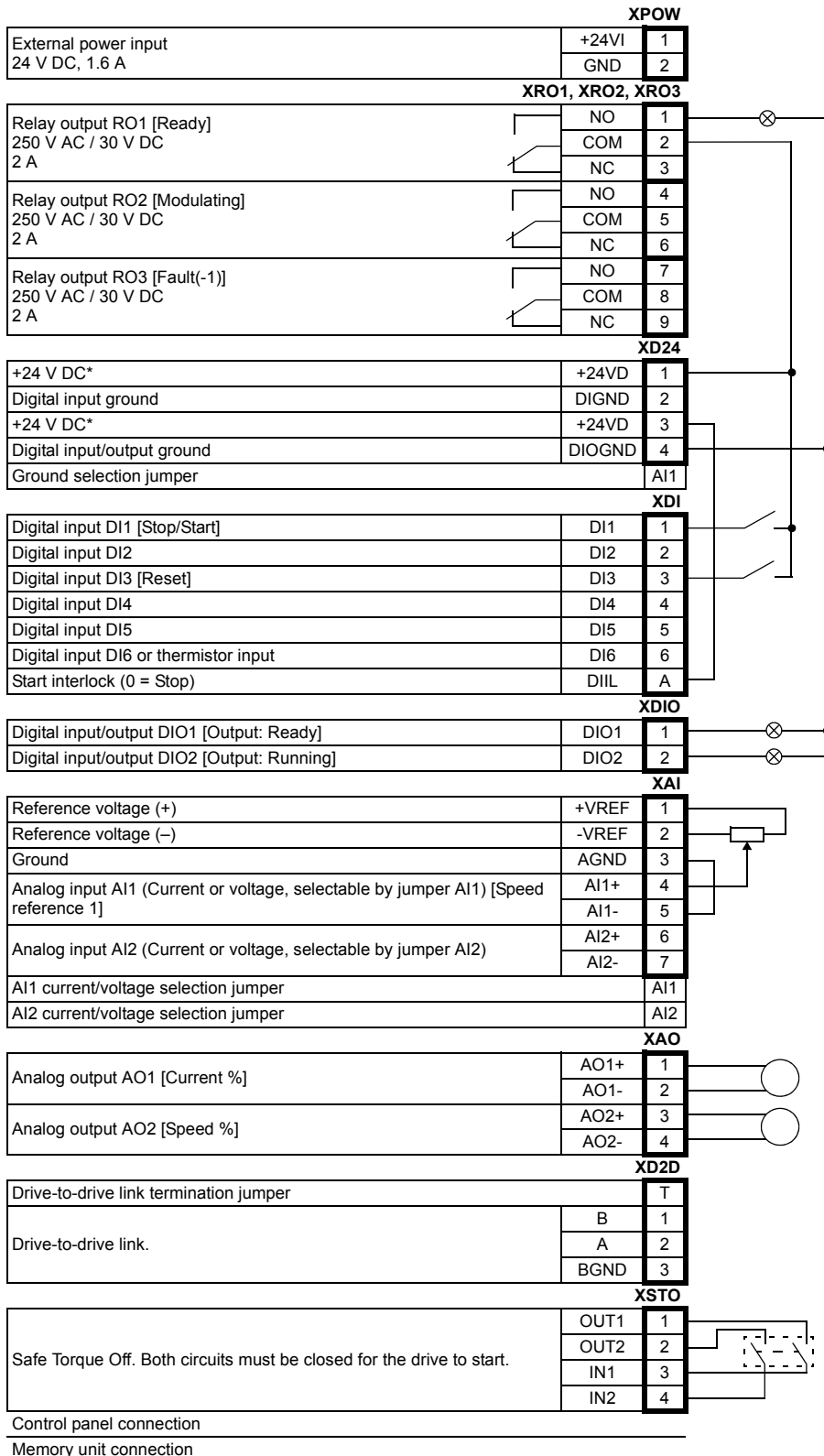
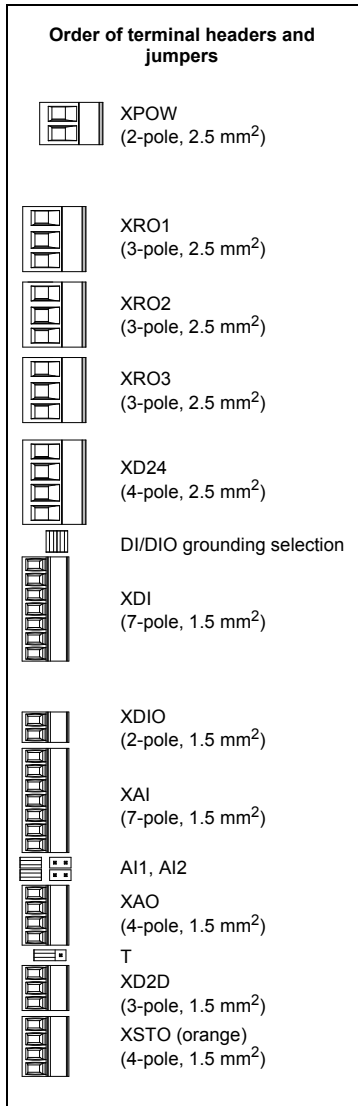

Jumpers on the control unit: DI/DIO

grounding selector (located between XD24 and XDI) – Determines whether the DIGND (ground for digital inputs DI1...DI5) floats, or if it is connected to DIOGND (ground for DI6, DIO1 and DIO2). If DIGND floats, the common of digital inputs DI1...DI5 should be connected to XD24:2. The common can be either GND or V_{cc} as DI1...DI5 are of the NPN/PNP type.

DIGND floats

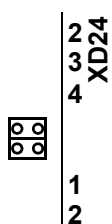

DIGND tied to DIOGND

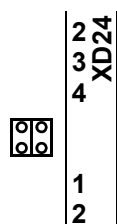

AI1 – Determines whether Analog input AI1 is used as a current or voltage input.

Current

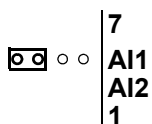

Voltage

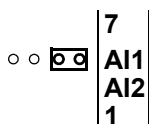

AI2 – Determines whether Analog input AI2 is used as a current or voltage input.

Current

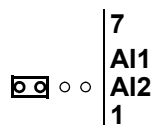

Voltage

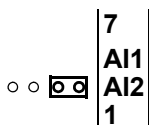

T – Drive-to-drive link termination. Must be set to the ON position when the drive is the last unit on the link.

Termination ON



Termination OFF



Continue with drive start-up according to the instructions in the appropriate *Quick Start-up Guide*.

Mounting the clamp plate

The clamp plate can be fastened at the top or the bottom of the JCU Control Unit.

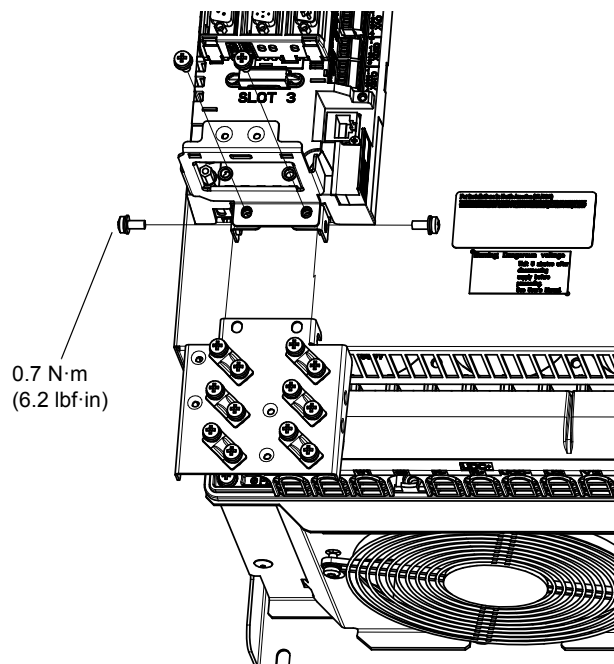

Routing the control cables

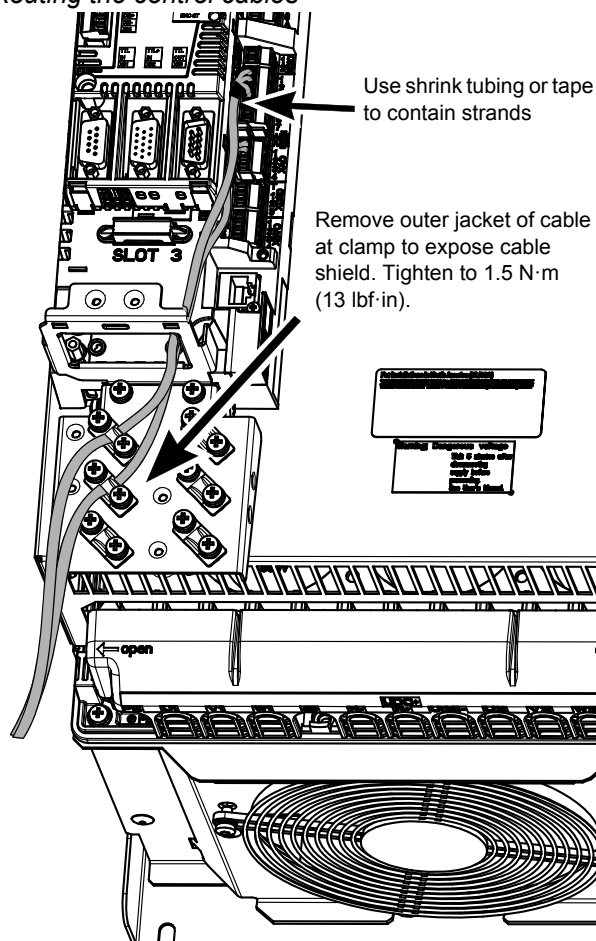

Technical data

UL checklist

- The ACS850-04 is an IP20 (UL open type) drive to be used in a heated, indoor controlled environment. The drive must be installed in clean air according to enclosure classification. Cooling air must be clean, free from corrosive materials and electrically conductive dust. See the *Hardware Manual* for detailed specifications.
- The maximum ambient air temperature is 40 °C (104 °F) at rated current. The current is derated for 40 to 55 °C (104 to 131 °F).
- The drive is suitable for use in a circuit capable of delivering not more than 100,000 rms symmetrical amperes, 500 V maximum.
- The cables located within the motor circuit must be rated for at least 75 °C (167 °F) in UL-compliant installations.
- The input cable must be protected with fuses or circuit breakers. Suitable IEC (class gG) and UL (class T) fuses are listed in the *Technical data* section of the *Hardware Manual*. For suitable circuit breakers, contact your local ABB representative.
- For installation in the United States, branch circuit protection must be provided in accordance with the National Electrical Code (NEC) and any applicable local codes. To fulfill this requirement, use the UL classified fuses.
- For installation in Canada, branch circuit protection must be provided in accordance with Canadian Electrical Code and any applicable provincial codes. To fulfill this requirement, use the UL classified fuses.
- The drive provides overload protection in accordance with the National Electrical Code (NEC). See the appropriate *Firmware Manual* for overload protection settings.

Hurtig installationsvejledning – ACS850-04

Om denne vejledning

Denne vejledning indeholder grundlæggende oplysninger om mekanisk og elektrisk installation af ACS850-04-drevmodul (55 til 200 kW). Du finder den komplette dokumentation i *ACS850-04 Drive Modules (55...200 kW, 60...200 hp) Hardware Manual* (kode: 3AUA0000045487 [på engelsk]).

Sikkerhedsinstruktioner



ADVARSEL! Al elektrisk installation og alt vedligeholdelsesarbejde på drevet skal udføres af en autoriseret installatør.

Arbejd aldrig på drevet, bremsechopperkredsen, motorkablet eller motoren, når netspændingen er tilsluttet drevet. Sørg altid for at sikre dette ved at måle, at der ikke er nogen spænding til stede.

En roterende permamagnetmotor kan generere en farlig spænding. Lås motorakslen mekanisk, før du tilslutter en permamagnetmotor til drevet, og før du udfører arbejde på et drevsystem, der er tilsluttet en permamagnetmotor.

Mekanisk installation



ADVARSEL! Hvis drevet skal tilsluttes til et IT-net (dvs. ikke jordet net eller et jordet net med høj modstand [over 30 ohms]), skal det interne EMC-filter frakobles. Dette

bør gøres, før drevet installeres mekanisk. Detaljerede instruktioner findes i *hardwaremanualen*.

Fastgør drevmodul til væggen med fire skruer.

Tilslutning af effektkabler

Tilslutningsdiagram

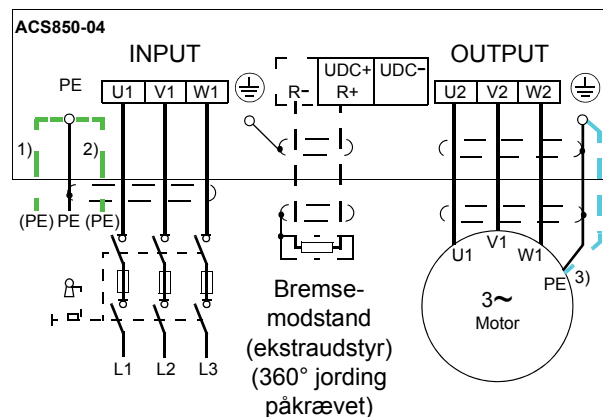

Noter:

- Anvend ikke et ikke-skærmet eller asymmetrisk motorkabel. Det anbefales også at anvende et skærmet kabel som netkabel (indgangs-).
- Hvis der bruges et skærmet netkabel (indgangs-), og skærmens ledeevne er mindre end 50 % af en faseleders ledeevne, skal der bruges et kabel med en jordleder (1) eller en separat PE-leder (2).
- Brug en separat PE-leder (3) til motorkabling, hvis kabelskærmens ledeevne er mindre end 50 % af en faseleders ledeevne, og kablet ikke har nogen symmetriske jordledere.

Hvis der udover skærmleder er en symmetrisk jordleder i motorkablet, tilsluttes jordlederen jordterminalen både i drev- og motorenden.

Tilslutningsprocedure

Der er vist eksempler på tilslutning nedenfor. Tilspændingsmomenter er vist på side 11 og på relevante steder i teksten.

- Fjern plastikafdækningen fra hovedterminalen. Løft op fra hjørnet med en skruetrækker.
- Forbind effektkablenes snoede skærme og separate jordledere til drevmodules jordterminaler.
- Forbind forsyningskablets faseledere med terminalerne U1, V1 og W1 samt motorkablets faseledere med terminalerne U2, V2 og W2. Den anbefalede afisolerede længde er 16 mm (0,63") for modulstørrelse E0 og 28 mm (1,1") for modulstørrelse E.
- Fastgør kablerne mekanisk udvendigt på drevmodulet.
- Skær huller til de installerede kabler i den klare plastikafdækning, der passer til effektkablerne. Pres afskærmningen på terminalerne.
- Forbind de andre ender af effektkablerne. Vær af sikkerhedsmæssige årsager særlig opmærksom på tilslutning af jordledere.

Modulstørrelse E: Kabelskoinstallation (16 til 70 mm² [AWG6 til AWG2/0] kabler)

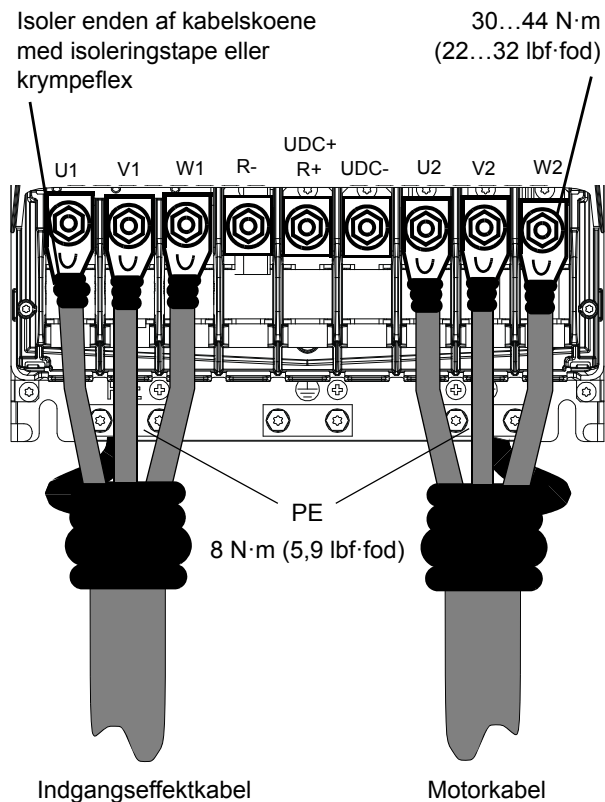

Eksempler på tilslutning

Modulstørrelse E0: Installation af skrueterminal

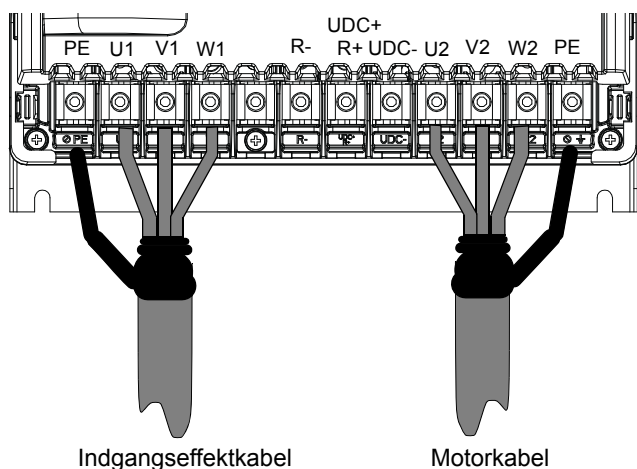

Modulstørrelse E: Installation af skrueterminal (95 til 240 mm² [AWG3/0 til 500MCM] kabler)

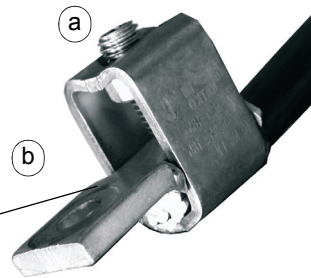
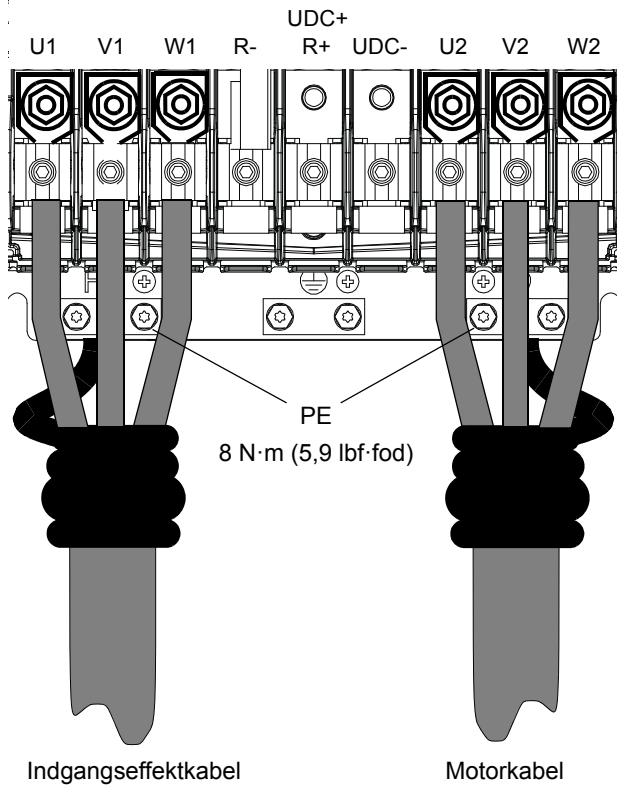

- Slut kablet til terminalen. Tilspænd sekskantskruen til 20...40 N·m (15...30 lbf·fod).
- Slut terminalen til drevet. Tilspænd til 30...44 N·m (22...32 lbf·fod).



ADVARSEL! Hvis ledertværsnittet mindre end 95 mm² (3/0 AWG), skal der anvendes en trykklemme. Et kabel med ledertværsnit mindre end 95 mm² (3/0 AWG), som tilsluttes denne terminal, vil løsne sig og kan medføre beskadigelse af drevet.

Ledningsstørrelser, der accepteres af effekterterminaler

Drevtype ACS850-04...	Ledningsstørrelse
-103A-5, -144A-5	6 ... 70 mm ²
-166A-5...-290A-5	95 ... 240 mm ²

Tilspændingsmomenter

Drevtype ACS850-04...	Netterminaler	PE
	N·m (lbf·ft)	N·m (lbf·ft)
-103A-5, -144A-5	15 (11)	15 (11)
-166A-5...-290A-5	Kabelskoinstallation 30...44 (22...32)	8 (5,9)
	Sekskantskrue 20...40 (15...30) Installation af skrueterminal 30...44 (22...32)	8 (5,9)

Installation af styrekabler

Diagram over default I/O-tilslutninger

Noter:

[Default-indstilling med ACS850-standardstyreprogram (fabriksmakro).

*Total maks. strøm: 200 mA

Den viste fortrængning tjener udelukkende til illustration.

Se oplysninger om jumperindstillinger i teksten.

Ledningsstørrelser og fastspændingsmomenter:

XPOW, XRO1, XRO2, XRO3, XD24:
0,5 ... 2,5 mm² (24...12 AWG). Torque:
0,5 N·m (5 lbf-tommer)

XDI, XDIO, XAI, XAO, XD2D, XSTO:
0,5 ... 1,5 mm² (28...14 AWG). Torque:
0,3 N·m (3 lbf-tommer)

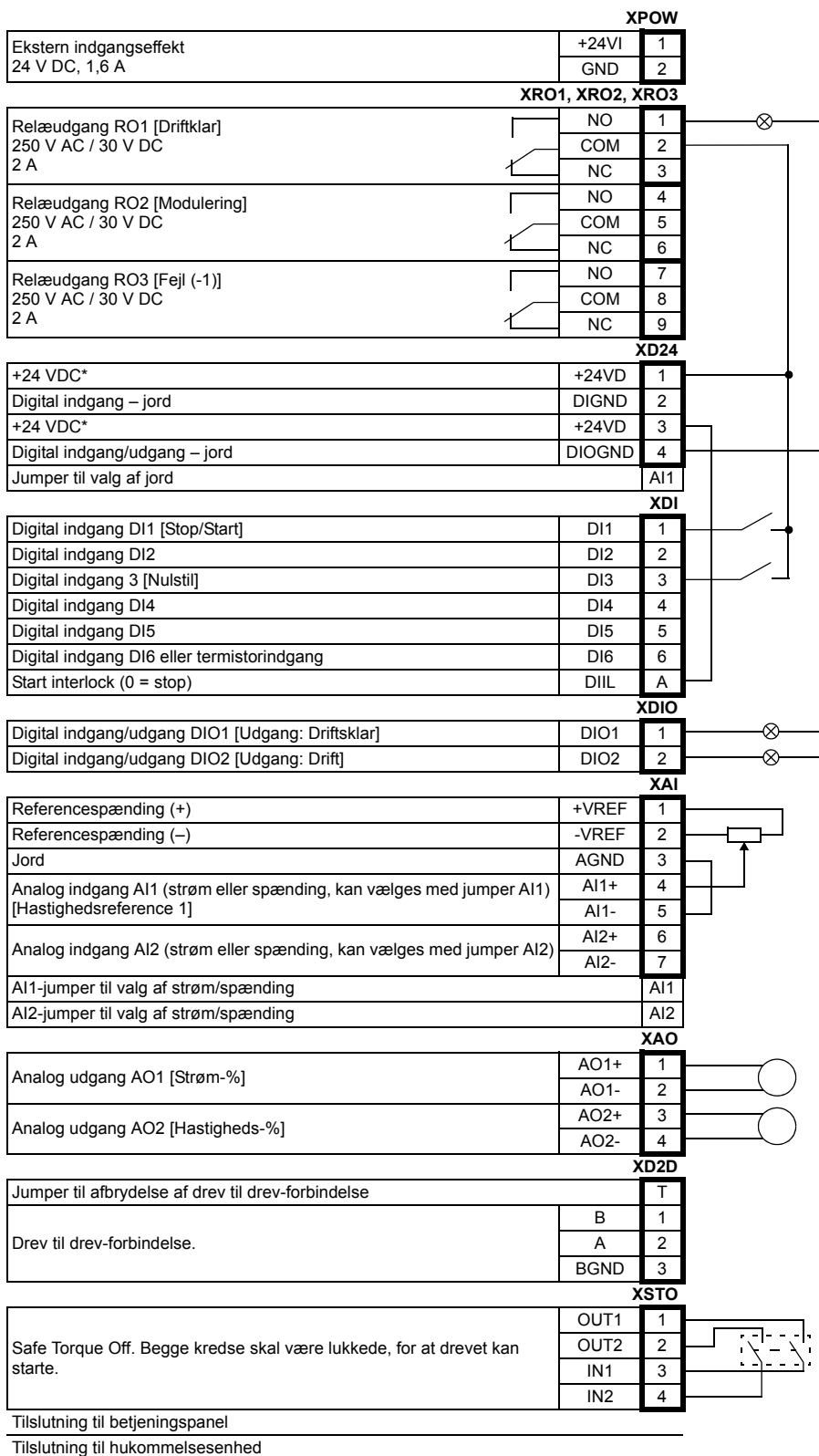
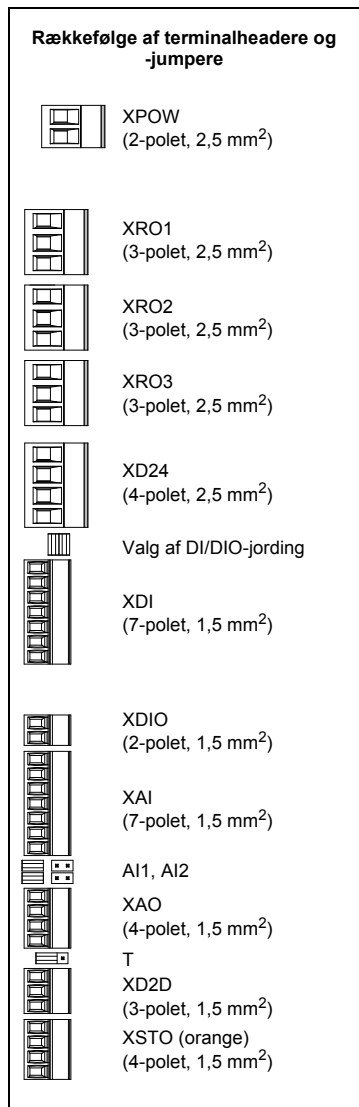

Jumpere på styreenheden: Valg af DI/DIO-jording (placeret mellem XD24 og XDI) – Bestemmer, om DIGND (jording til digitale indgange DI1...DI5) flyder, eller om den er forbundet til DIOGND (jord for DI6,DIO1 og DIO2). Hvis DIGND flyder, skal common-enheden for digitalindgangene DI1...DI5 forbindes til XD24:2. Common-enheden kan være enten GND eller V_{CC} , da DI1...DI5 er af typen NPN/PNP.

DIGND er flydende DIGND bundet til DIOGND

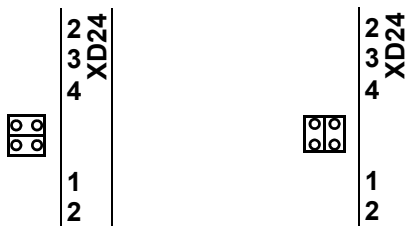

AI1 – Afgør, om analogindgang AI1 bruges som en strøm- eller spændingsindgang.

Strøm Spænding



AI2 – Afgør, om analog indgang AI2 bruges som en strøm- eller spændingsindgang.

Strøm Spænding



T – Afbrydelse af drev til drev-forbindelse. Skal være angivet til ON-position, når drevet er den sidste enhed i forbindelsen.

Terminering ON Terminering OFF



Fortsæt med opstart af drevet i henhold til instruktionerne i den relevante *Quick Start-up Guide*.

Montering af aflastningspladen

Aflastningspladen kan fastgøres i toppen eller bunden af JCU-styreenheden.

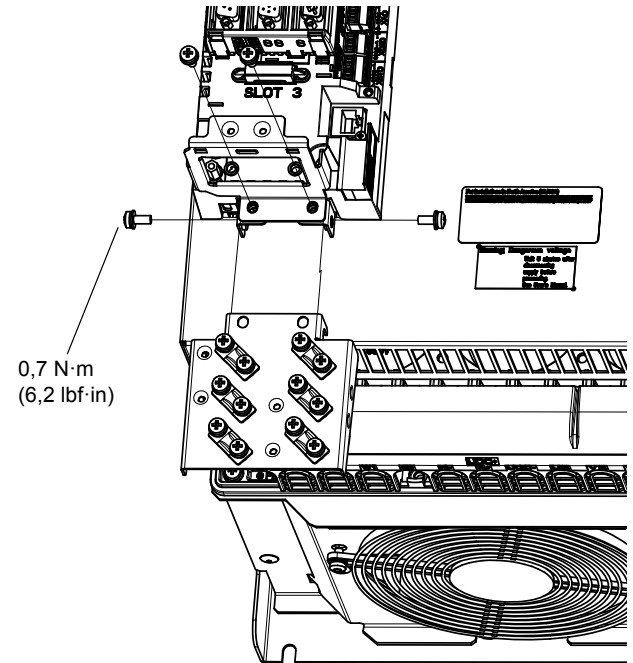

Føring af styrekablerne

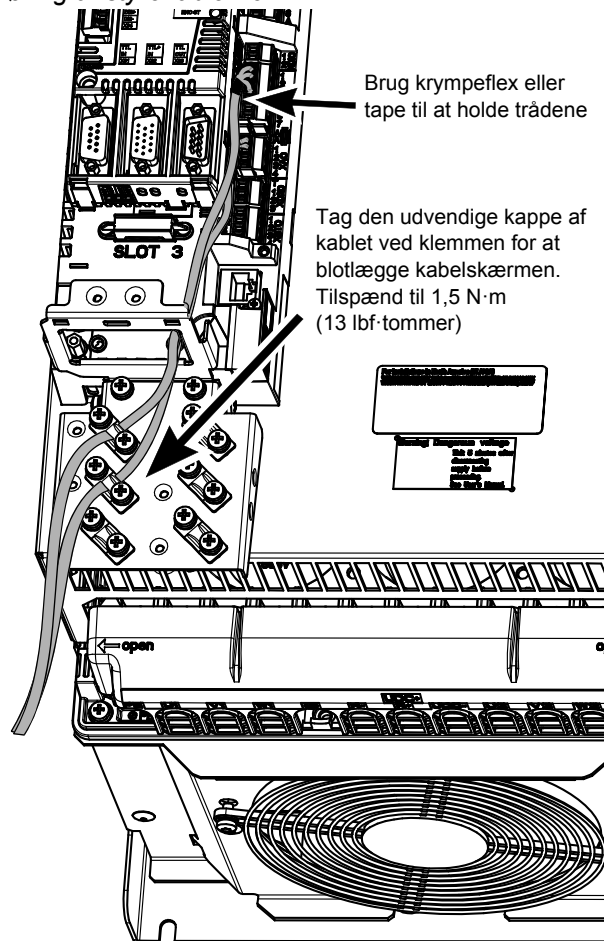

- Kablerne i motorkredsløbet skal være dimensioneret til mindst 75 °C (167 °F) i installationer med UL-overensstemmelse.
- Netkablet skal beskyttes med sikringer eller maksimalafbrydere. Passende IEC- (klasse gG) og UL-sikringer (klasse T) er vist i afsnittet om *tekniske data* i *hardwaremanualen*. Kontakt din lokale ABB-repræsentant for at få oplysninger om passende maksimalafbrydere.
- Ved installation i USA skal netkredsløbsbeskyttelse udføres i henhold til the National Electrical Code (NEC) samt enhver lokalt gældende kode. Brug UL-klassificerede sikringer for at overholde dette krav.
- Ved installation i Canada skal netkredsløbsbeskyttelse udføres i henhold til Canadian Electrical Code samt enhver lokalt gældende kode. Brug UL-klassificerede sikringer for at overholde dette krav.
- Drevet har overbelastningsbeskyttelse iht. National Electrical Code (NEC). Du kan finde oplysninger om indstillinger for overbelastningsbeskyttelse i den relevante *firmwaremanual*.

Tekniske data

UL-checkliste

- ACS850-04 er et IP20-drev (UL åben type), der er beregnet til brug i et opvarmet, indendørs kontrolleret miljø. Drevet skal monteres i ren luft i overensstemmelse med kapslingsklasse. Køleluften skal være ren og fri for korroderende materialer og elektrisk ledende støv. Detaljerede specifikationer findes i *hardwaremanualen*.
- Den maksimale omgivelsestemperatur er 40 °C (104 °F) ved nominel strøm. Strømmen er reduceret for 40 til 55 °C (104 til 131 °F).
- Drevet er egnet til anvendelse i netværk, som ikke leverer mere end 100.000 A (rms værdi, 500 V maximum).

Kurzanleitung für die Installation – ACS850-04

Informationen über diese Anleitung

Diese Anleitung enthält grundlegende Informationen zur mechanischen und elektrischen Installation des Frequenzumrichtermoduls ACS850-04 (55 bis 200 kW). Die vollständige Dokumentation finden Sie im *Hardware-Handbuch ACS850-04 Frequenzumrichtermodul (55 bis 200 kW, 60...200 hp)* (Code: 3AUA0000045487 [Englisch]).

Sicherheitsvorschriften



WARNUNG! Alle elektrischen Installations- und Wartungsarbeiten am Frequenzumrichter dürfen nur von qualifiziertem Fachpersonal durchgeführt werden.

Arbeiten Sie niemals bei eingeschalteter Spannung an dem Frequenzumrichter, dem Bremschopper, dem Motorkabel oder dem Motor. Stellen Sie immer durch eine Messung sicher, dass keine Spannung anliegt.

Ein drehender Permanentmagnet-Motor kann gefährliche Spannung erzeugen. Blockieren Sie die Motorwelle mechanisch, bevor Sie einen Permanentmagnet-Motor an den Frequenzumrichter anschließen und bevor Sie Arbeiten an einem Antriebssystem vornehmen, an das ein Permanentmagnet-Motor angeschlossen ist.

Mechanische Installation



WARNUNG! Wenn der Frequenzumrichter an ein IT-Netz angeschlossen werden soll (d.h. ein ungeerdetes oder hochohmig geerdetes Netz [über 30 Ohm]), muss der interne EMV-Filter des Frequenzumrichters

getrennt werden. Dies muss erfolgt sein, bevor der Frequenzumrichter montiert wird. Ausführliche Anweisungen finden Sie im *Hardware-Handbuch*.

Das Frequenzumrichtermodul wird mit vier Schrauben an der Wand befestigt.

Installation der Leistungskabel

Anschlussplan

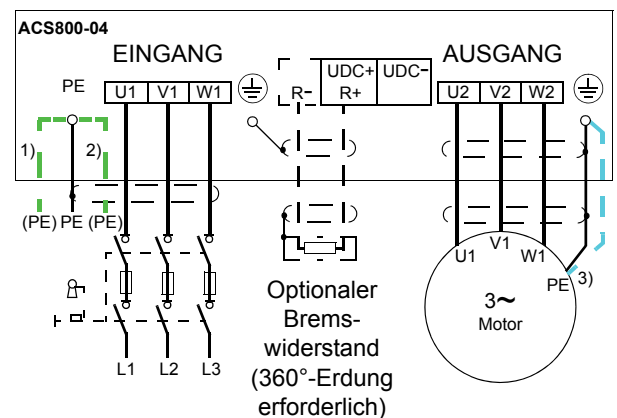

Hinweise:

- Kein ungeschirmtes oder asymmetrisches Motorkabel verwenden. Als Einspeisekabel sollte ebenfalls ein geschirmtes Kabel verwendet werden.
- Bei Verwendung von geschirmten Einspeisekabeln und einer Leitfähigkeit des Schirms von unter 50 % der Leitfähigkeit der Phasenleiter muss ein Kabel mit einem Erdungsleiter (1) oder ein separates PE-Kabel (2) verwendet werden.
- Bei der Motorverkabelung muss ein separates Erdungskabel (3) verwendet werden, wenn die Leitfähigkeit des Kabelabschirms weniger als 50 % der Leitfähigkeit eines Phasenleiters beträgt und das Kabel keine symmetrischen Erdungsleiter hat.

Ist im Motorkabel zusätzlich zum Kabelschirm ein symmetrisch aufgebauter Erdungsleiter vorhanden, muss dieser an die Erdungsklemmen des Frequenzumrichters und des Motors angeschlossen werden.

Vorgehensweise bei Anschlussarbeiten

Kabelanschlussbeispiele sind nachfolgend dargestellt. Anzugsmomente sind auf Seite 17 und zu den jeweiligen Punkten im Text angegeben.

- Entfernen Sie die Plastikabdeckung über den Hauptklemmen. Mit einem Schraubendreher von den Ecken her anheben.
- Verbinden Sie die verdrehten Schirme und Erdungsleiter der Leistungskabel mit den Erdungsklemmen des Frequenzumrichtermoduls.
- Die Phasenleiter des Einspeisekabels an die Klemmen U1, V1 und W1 und die Phasenleiter des Motorkabels an die Klemmen U2, V2 und W2 anschließen. Die Kabel auf 16 mm (0,63") bei Baugröße E0 und auf 28 mm (1,1") bei Baugröße E abisolieren.
- Sichern Sie die Kabel mechanisch außerhalb des Frequenzumrichtermoduls.
- In die durchsichtige Kunststoffabdeckung Durchführungen für die installierten Kabel schneiden. Die Abdeckung wieder über den Klemmen anbringen.
- Die anderen Enden der Leistungskabel anschließen. Aus Sicherheitsgründen erfordert der Anschluss der Erdungsleiter besondere Sorgfalt.

Kabelanschluss-Beispiele

Baugröße E0: Schraubklemmen-Installation

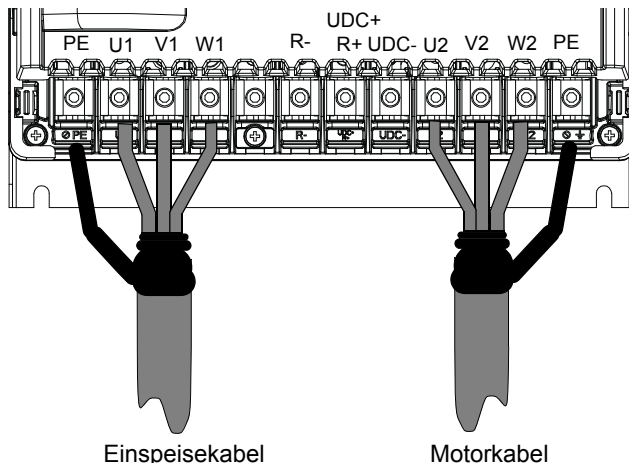

Baugröße E: Kabelschuh-Installation (Kabel 16 bis 70 mm² [AWG6 bis AWG2/0])

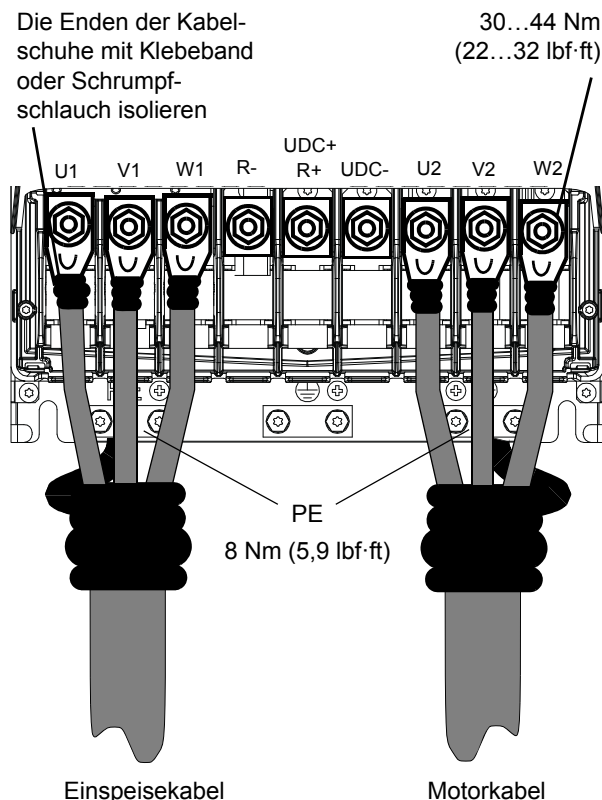

Baugröße E: Schraubklemmen-Installation
 (Kabel 95 bis 240 mm² [AWG3/0 bis AWG500])

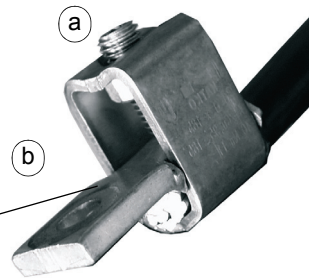
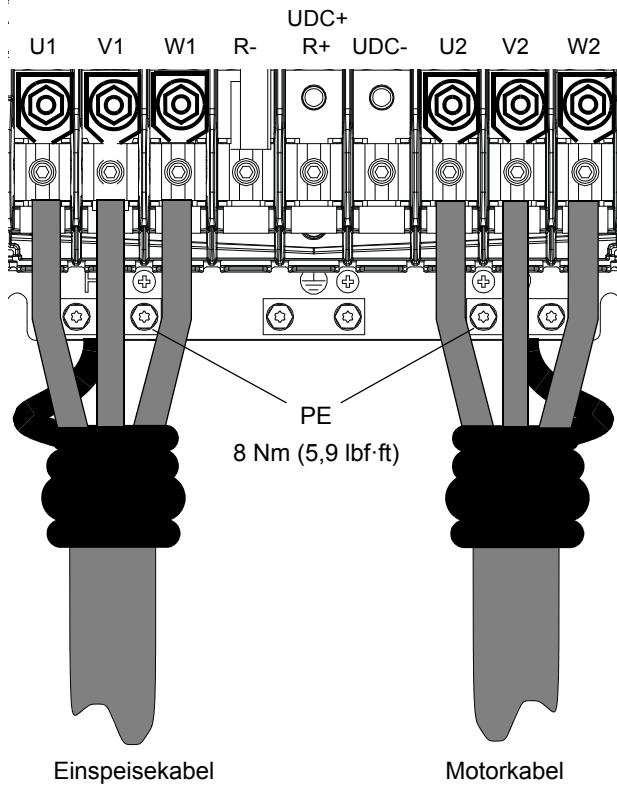

- a. Anschluss des Kabels an die Klemme. Innensechskantschraube mit 20...40 Nm (15...30 lbf-ft) festziehen.
- b. Anschluss der Klemme an den Frequenzumrichter. Anzugsmoment 30...44 Nm (22...32 lbf-ft).



WARNUNG! Bei einer Leitergröße von weniger als 95 mm² (3/0 AWG) muss eine Crimp-Klemme verwendet werden. Ein kleineres Kabel als 95 mm² (3/0 AWG) kann sich am Anschluss lösen und den Frequenzumrichter beschädigen.

Kabelgrößen der Leistungsklemmen

Frequenzumrichter-Typ ACS850-04...	Kabelgröße
-103A-5, -144A-5	6 ... 70 mm ²
-166A-5...-290A-5	95 ... 240 mm ²

Anzugsmomente

Frequenzumrichter-Typ ACS850-04...	Leistungsanschlüsse	PE
	Nm (lbf-ft)	Nm (lbf-ft)
-103A-5, -144A-5	15 (11)	15 (11)
-166A-5...-290A-5	Kabelschuh-Installation 30...44 (22...32)	8 (5.9)
	Innensechskant 20...40 (15...30) Schraubklemmen-Installation 30...44 (22...32)	8 (5.9)

Anschluss der Steuerkabel

Standard E/A-Anschlüsse

Hinweise:

[Standardeinstellung beim ACS850 Standard-Regelungsprogramm (Makro Werkseinstellung).

*Gesamter maximaler Strom: 200 mA

Gezeigte Anschlüsse dienen nur als Beispiel.

Weitere Informationen zu den Anschlüssen und Jumpern enthält der folgende Text.

Kabelquerschnitte und Anzugsmomente:

XPOW, XRO1, XRO2, XRO3, XD24:
0.5 ... 2.5 mm² (24...12 AWG).
Anzugsmoment: 0.5 Nm (5 lbf-in)

XDI, XDIO, XAI, XAO, XD2D, XSTO:
0.5 ... 1.5 mm² (28...14 AWG).
Anzugsmoment: 0.3 Nm (3 lbf-in)

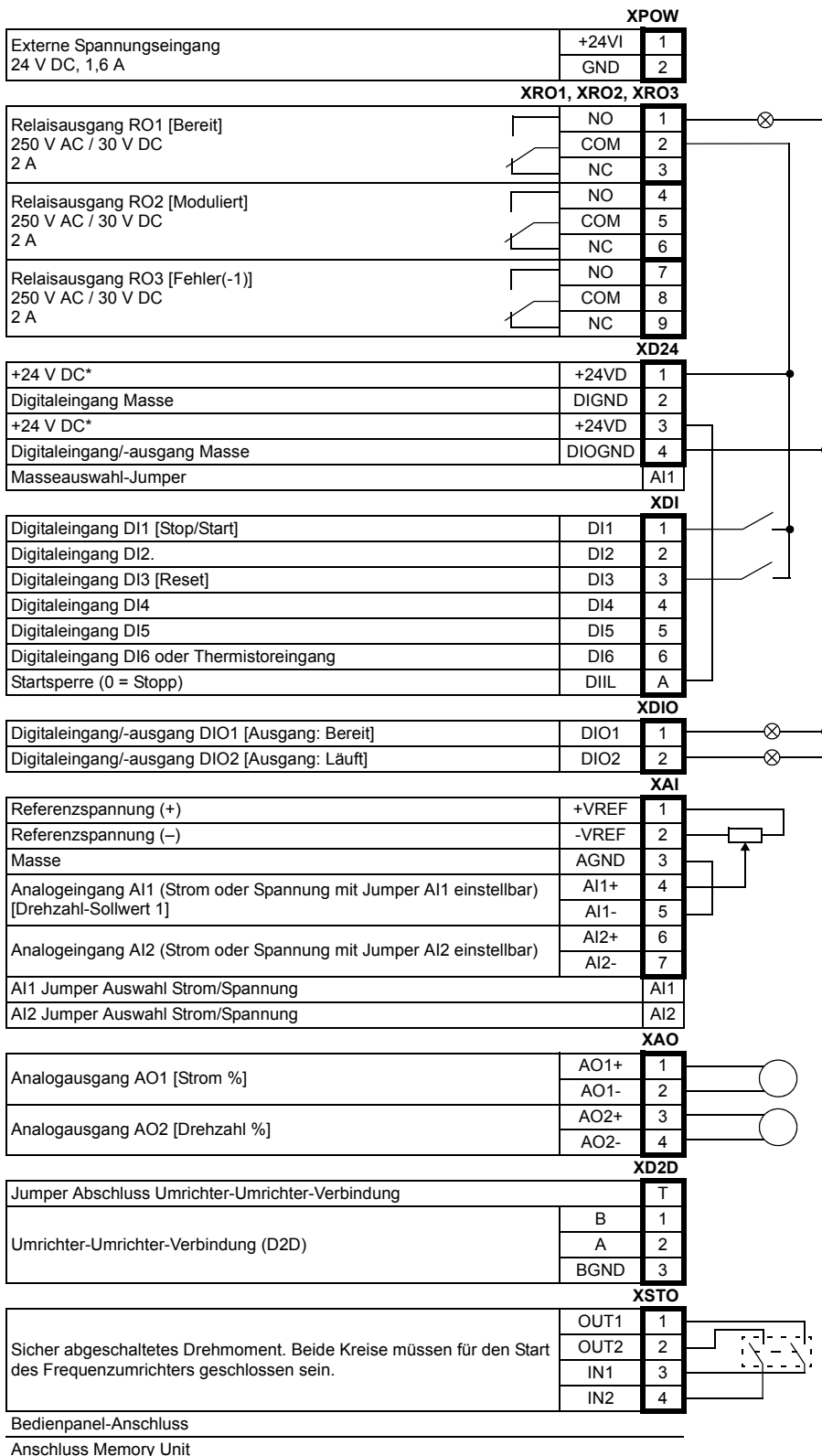
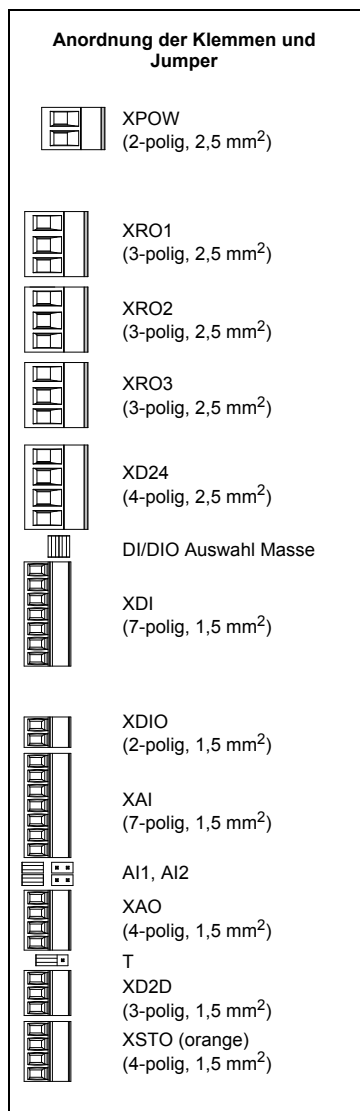

Jumper auf der Regelungseinheit:

DI/DIO-Masse-Auswahl (zwischen XD24 und XDI) – Einstellung, ob DIGND (Masse Digital-eingänge DI1...DI5) massefrei sind, oder an DIOGND (Masse für DI6, DIO1 und DIO2) angeschlossen sind. Wenn DIGND massefrei ist, sollte die Masse der Digitaleingänge DI1...DI5 an XD24:2 gelegt werden. An DIGND kann entweder GND oder V_{CC} angeschlossen werden, da DI1...DI5 vom Typ NPN/PNP sind.

DIGND massefrei

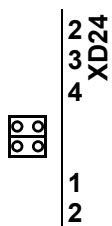

DIGND verbunden mit DIOGND

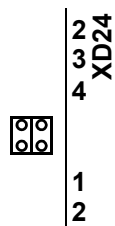

AI1 – Legt fest, ob Analogeingang AI1 als Strom- oder Spannungseingang verwendet wird.

Strom

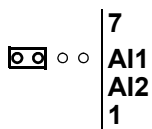

Spannung

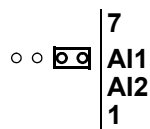

AI2 – Legt fest, ob Analogeingang AI2 als Strom- oder Spannungseingang verwendet wird.

Strom

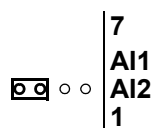

Spannung

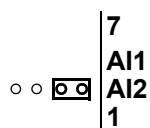

T – Abschluss der Umrichter-Umrichter-Verbindung. Muss auf Position EIN gesetzt werden, wenn der Frequenzumrichter die letzte Einheit in der Verbindung ist.

Abschluss EIN



Abschluss AUS



Setzen Sie die Inbetriebnahme des Frequenzumrichters gemäß den Anweisungen in der jeweiligen *Kurzanleitung für die Inbetriebnahme* fort.

Montage des Kabelklemmenblechs

Das Kabelklemmen-/abfangblech kann oben oder unten an der Regelungseinheit JCU befestigt werden.

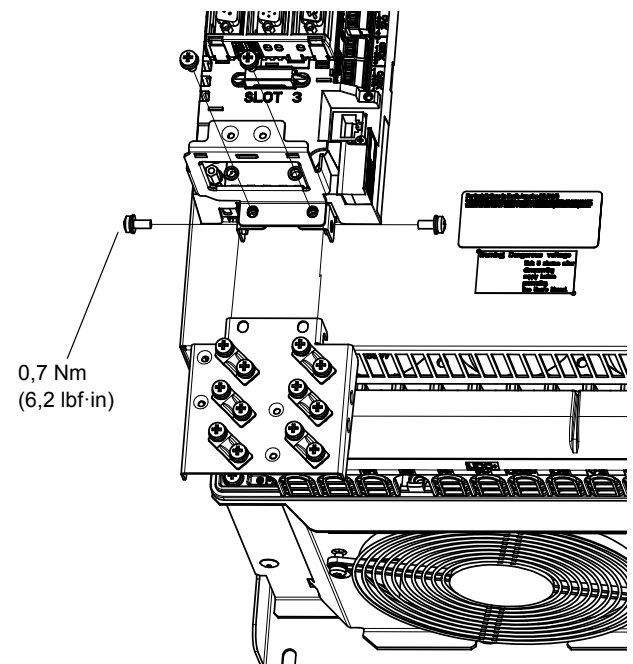

Verlegen der Steuerkabel

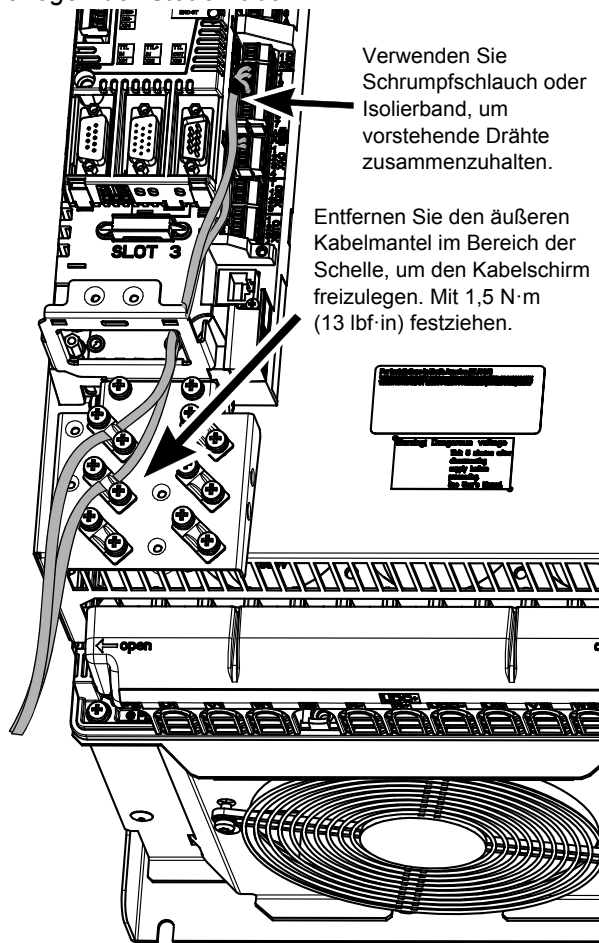

- Der Frequenzumrichter eignet sich für die Verwendung in einem Netz mit einem Kurzschlusswert von nicht mehr als eff. 100.000 A symm. Kurzschlussstrom, maximal 500 V.
- Die Kabel innerhalb des Motorschaltkreises müssen für mindestens 75 °C (167 °F) in UL-kompatiblen Installationen ausgelegt sein.
- Das Eingangskabel muss durch geeignete Sicherungen oder Leistungsschalter geschützt sein. Geeignete IEC- (Klasse gG) und UL- (Klasse T) Sicherungen werden in den *Technischen Daten* im *Hardware-Handbuch* angegeben. Informationen zu geeigneten Leistungsschaltern bzw. Schutzschaltern erhalten Sie von Ihrer ABB-Vertretung.
- Zur Installation in den Vereinigten Staaten muss der Kurzschluss-Schutz dem National Electrical Code (NEC) und allen anwendbaren lokalen Vorschriften genügen. Verwenden Sie UL-klassifizierte Sicherungen, um diese Anforderung zu erfüllen.
- Zur Installation in Kanada muss der Kurzschluss-Schutz dem Canadian Electrical Code und allen anwendbaren Vorschriften der Provinzen genügen. Verwenden Sie UL-klassifizierte Sicherungen, um diese Anforderung zu erfüllen.
- Der Frequenzumrichter bietet einen Überlastungsschutz gemäß dem National Electrical Code (NEC). Das jeweilige *Firmware-Handbuch* enthält die Einstellungen zum Überlastschutz.

Technische Daten

UL-Checkliste

- Der ACS850-04 ist ein IP20 (UL-Typ offen) Frequenzumrichter zur Verwendung in beheizten Innenräumen. Der Frequenzumrichter muss in sauberer Luft gemäß Gehäuseselektifizierung installiert werden. Die Kühlluft muss sauber, frei von korrosiven Materialien und elektrisch leitfähigem Staub sein. Ausführliche Spezifikationen finden Sie im *Hardwarehandbuch*.
- Die maximal zulässige Temperatur der Umgebungsluft bei Nennstrom beträgt 40 °C (104 °F). Der Strom muss bei 40 bis 55 °C (104 bis 131 °F) reduziert werden.

Guía de instalación rápida – ACS850-04

Acerca de esta guía

Esta guía contiene información muy básica acerca de la instalación mecánica y eléctrica del módulo de convertidor de frecuencia ACS850-04 (de 55 a 200 kW). Para obtener la documentación completa, consulte el Manual de Hardware de los módulos de convertidor de frecuencia ACS850-04 (de 55 a 200 kW, de 60 a 200 CV) (código: 3AUA0000045487 [inglés]).

Instrucciones de seguridad



ADVERTENCIA: Todos los trabajos de instalación eléctrica y mantenimiento realizados en el convertidor deben ser ejecutados únicamente por electricistas cualificados.

Nunca trabaje en el convertidor, el circuito del chopper de frenado, el cable de motor o el motor con la alimentación del convertidor conectada. Realice siempre una medición para verificar que no existe tensión.

Un motor de imanes permanentes en rotación puede generar una tensión peligrosa. Bloquee mecánicamente el eje del motor antes de conectar un motor de imanes permanentes al convertidor, así como antes de comenzar a trabajar en un sistema de convertidor de frecuencia conectado a un motor de imanes permanentes.

Instalación mecánica



ADVERTENCIA: Si se prevé conectar el convertidor a un sistema de alimentación IT (es decir, un sistema de alimentación sin conexión a tierra o con una tierra de alta resistencia [superior a los 30 ohmios]), el filtrado de compatibilidad electromagnética del convertidor debe desconectarse. Esto debe hacerse antes de la instalación mecánica del convertidor. Consulte el *Manual de Hardware* para obtener instrucciones detalladas.

Fije el módulo del convertidor a la pared mediante cuatro tornillos.

Instalación de los cables de alimentación

Diagrama de conexiones

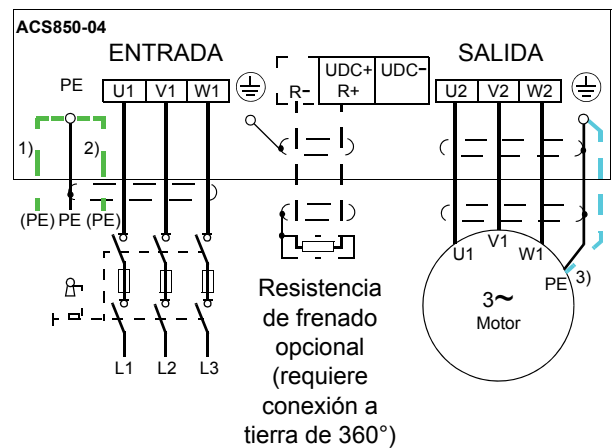

Notas:

- No utilice un cable de motor sin apantallamiento o de estructura asimétrica. Se recomienda usar igualmente un cable apantallado como cable de alimentación (entrada).
- Si se utiliza cable de alimentación (entrada) apantallado y la conductividad de la pantalla

es inferior al 50% de la conductividad de un conductor de fase, utilice un cable con un conductor de tierra (1) o un cable de tierra de protección separado (2).

– En el caso de los cables de motor, utilice un cable de conexión a tierra separado (3) si la conductividad de la pantalla del cable es inferior al 50% de la conductividad de un conductor de fase y el cable no tiene conductores de tierra simétricos.

Si existe un conductor de conexión a tierra de estructura simétrica en el cable de motor además de la pantalla conductora, conecte el conductor a los conectores de tierra tanto en el extremo del convertidor de frecuencia como en el del motor.

Procedimiento de conexión

A continuación se muestran ejemplos de cableado. Los pares de apriete se muestran en la página 23 y en los puntos del texto que así lo requieran.

- Retire la envoltura de plástico que cubre los bornes principales. Levante por la esquina con la ayuda de un destornillador.
- Conecte los apantallamientos trenzados de los cables de alimentación y los conductores de conexión a tierra separados a los bornes de conexión a tierra del módulo de convertidor.
- Conecte los conductores de fase del cable de alimentación a los bornes U1, V1 y W1 y los conductores de fase del cable de motor a los bornes U2, V2 y W2. La longitud de pelado recomendada es de 16 mm (0,63 in) para el bastidor de tamaño E0 y 28 mm (1,1 in) para el bastidor de tamaño E.
- Sujete los cables mecánicamente al exterior del módulo de convertidor.
- Practique orificios para los cables instalados en la tapa de plástico transparente con el fin de alojar los cables de alimentación. Coloque la tapa a presión sobre los terminales.
- Conecte los otros extremos de los cables de alimentación. Para garantizar la seguridad de la instalación, preste especial atención a la conexión de los conductores de tierra.

Ejemplos de cableado

Bastidor E0: Instalación de terminales de tornillo

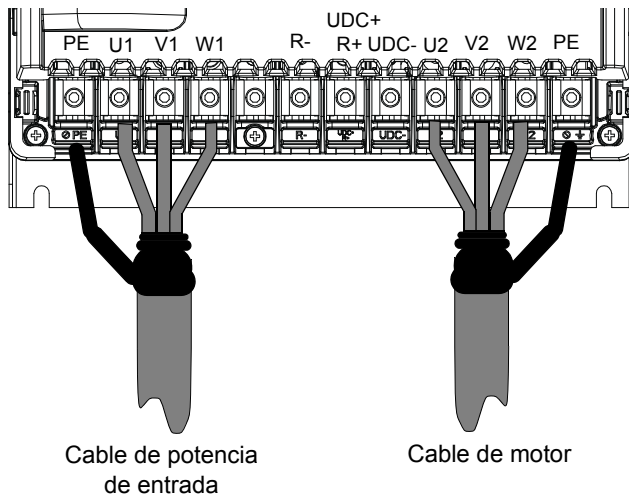

Bastidor E: Instalación de terminales de cable (cables de 16 a 70 mm² [AWG6 a AWG2/0])

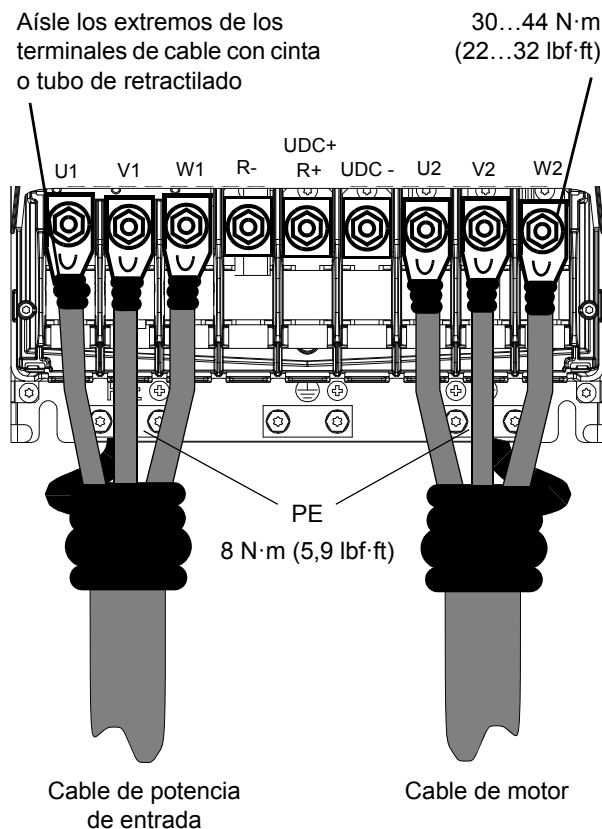

**Bastidor E: Instalación de terminales de tornillo
(cables de 95 a 240 mm² [AWG3/0 a 500MCM])**

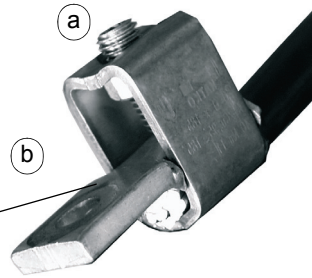
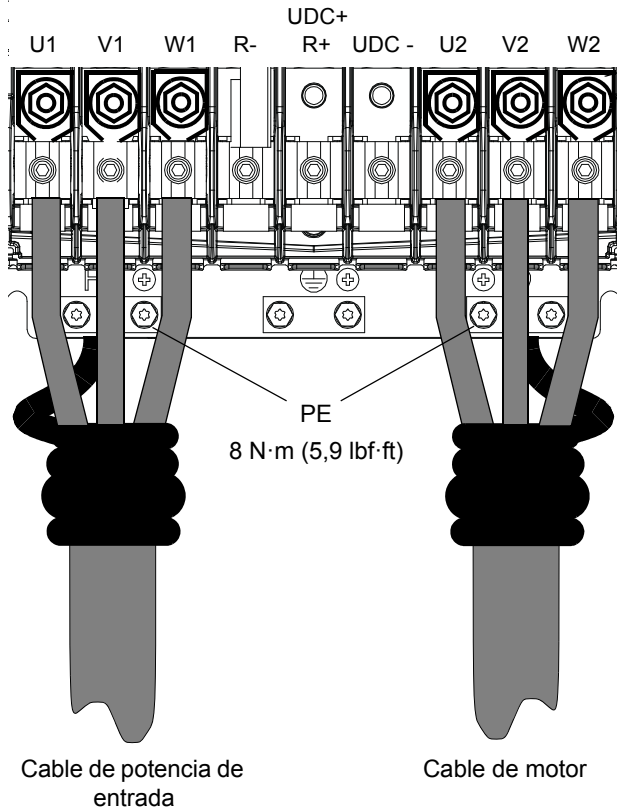

- a. Conecte el cable al borne. Apriete el tornillo Allen a 20...40 N·m (15...30 lbf·ft).
- b. Conecte el borne al convertidor. Apriete a 30...44 N·m (22...32 lbf·ft).



ADVERTENCIA: Si el tamaño de los hilos es inferior a 95 mm² (3/0 AWG), debe utilizarse un terminal engarzado. Un cable de tamaño inferior a 95 mm² (3/0 AWG) conectado a este terminal podría aflojarse y causar daños en el convertidor.

Tamaños de cable adecuados para terminales de alimentación

Modelo de convertidor ACS850-04...	Tamaño del cable
-103A-5, -144A-5	6 ... 70 mm ²
-166A-5...-290A-5	95 ... 240 mm ²

Pares de apriete

Modelo de convertidor ACS850-04...	Terminales de alimentación	PE
	N·m (lbf·ft)	N·m (lbf·ft)
-103A-5, -144A-5	15 (11)	15 (11)
-166A-5...-290A-5	Instalación de terminales de cable 30...44 (22...32)	8 (5,9)
	Tornillo Allen 20...40 (15...30) Instalación de terminales de tornillo 30...44 (22...32)	8 (5,9)

Instalación de los cables de control

Diagrama de conexiones de E/S por defecto

Notas:

[Ajuste predeterminado con el programa de control estándar del ACS850 (macro Fábrica).

*Intensidad máxima total: 200 mA

Las conexiones representadas en la figura son sólo a título demostrativo.

Consulte el texto para conocer los ajustes de los puentes.

Tamaños de cable y pares de apriete:

XPOW, XRO1, XRO2, XRO3, XD24:

0,5 ... 2,5 mm² (24...12 AWG). Par: 0,5 N·m (5 lbf·in)

XDI, XDIO, XAI, XAO, XD2D, XSTO:

0,5 ... 1,5 mm² (28...14 AWG). Par: 0,3 N·m (3 lbf·in)

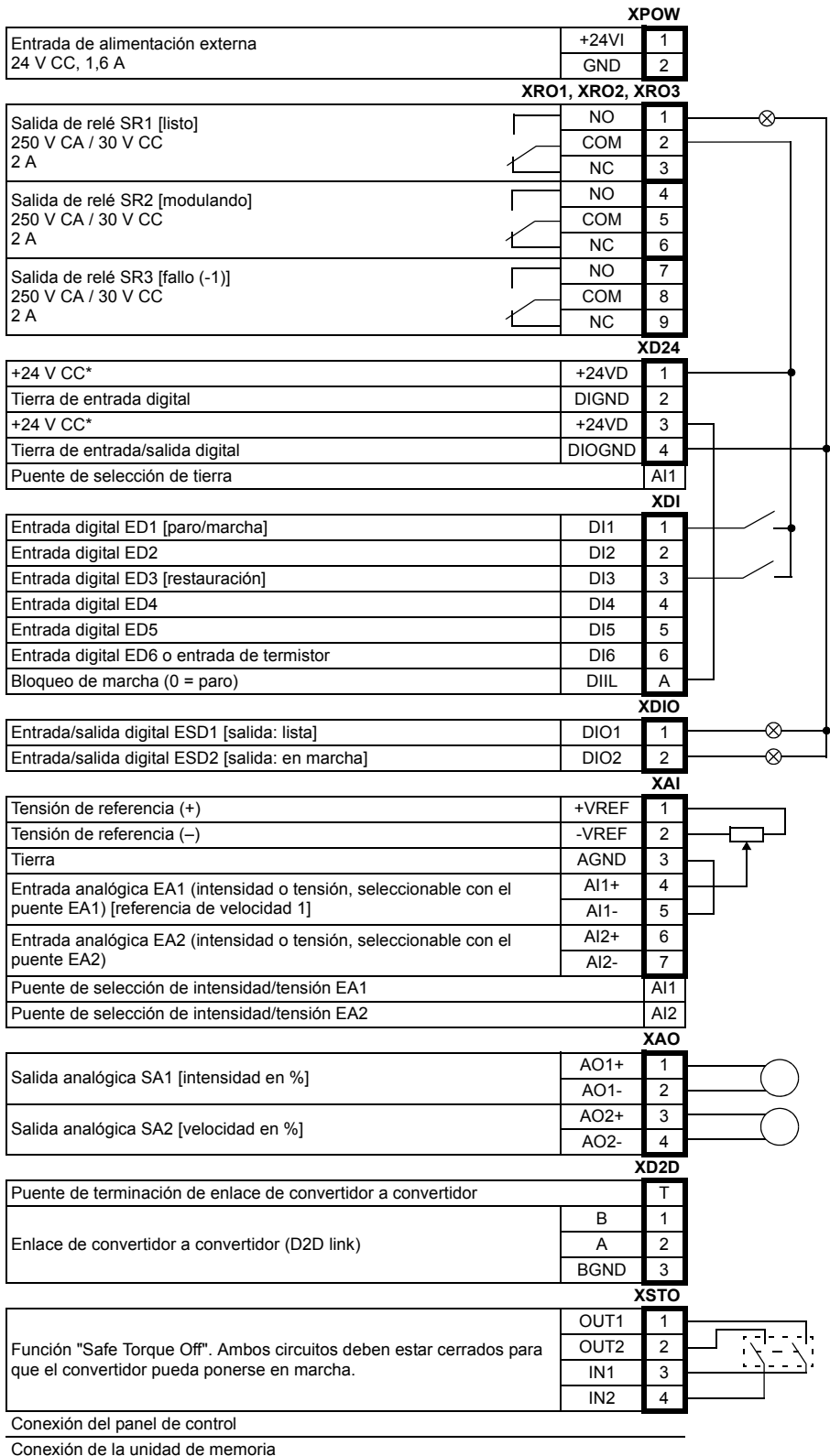
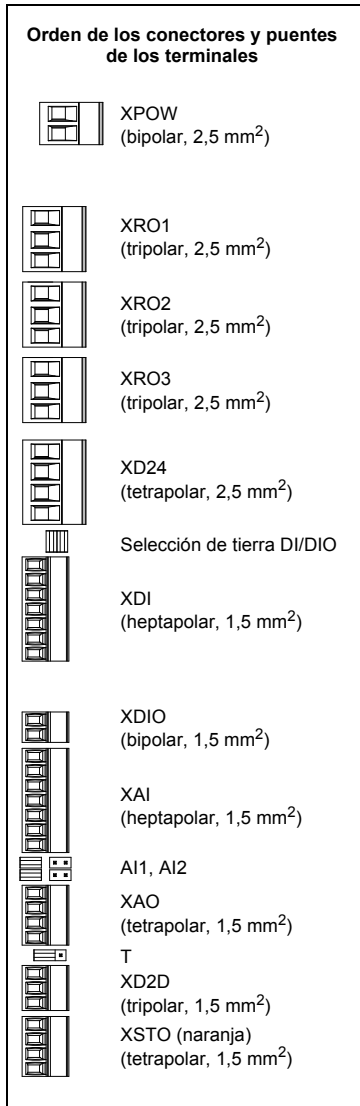

Puentes en la unidad de control: Selector de tierra ED/ESD (situado entre XD24 y XDI): determina si DIGND (tierra para las entradas digitales ED1...ED5) es flotante o si está conectada a DIOGND (tierra para las entradas ED6, ESD1 y ESD2). Si DIGND es flotante, la común de las entradas digitales ED1...ED5 debe conectarse a XD24:2. La común puede ser tanto GND como Vcc, puesto que ED1...ED5 son del tipo NPN/PNP.

DIGND flotante DIGND enlazada con DIOGND

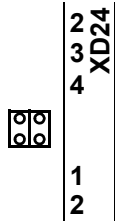
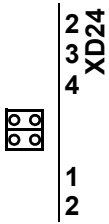

AI1 – Determina si la entrada analógica EA1 se utiliza como entrada de intensidad o de tensión.

Intensidad

Tensión

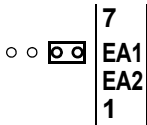
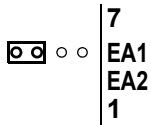

AI2 – Determina si la entrada analógica EA2 se utiliza como entrada de intensidad o de tensión.

Intensidad

Tensión

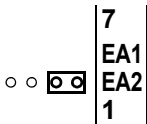
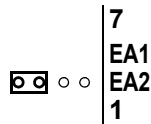

T – Terminación de enlace de convertidor a convertidor. Debe colocarse en la posición ON si el convertidor es la última unidad del enlace.

Terminación ON

Terminación OFF



Continúe con la puesta en marcha del convertidor conforme a las instrucciones de la *Guía rápida de puesta en marcha* correspondiente.

Montaje de la placa de fijación

La placa de fijación puede sujetarse a la parte superior o inferior de la unidad de control JCU.

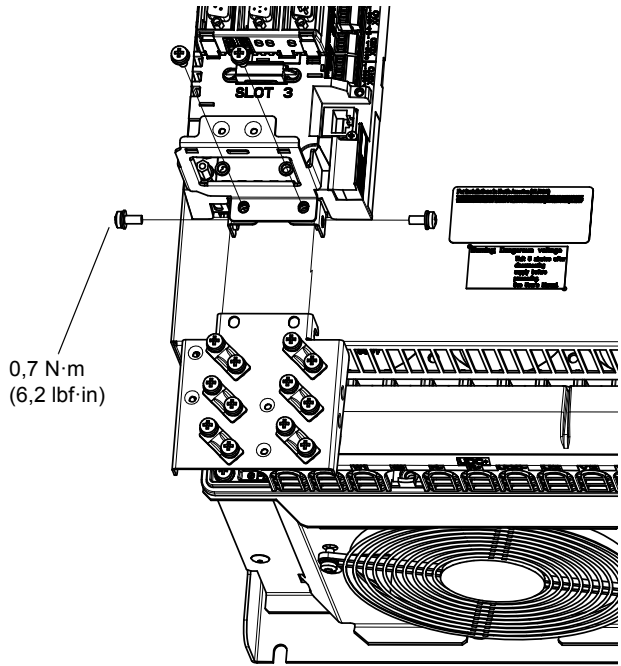

Recorrido de los cables de control

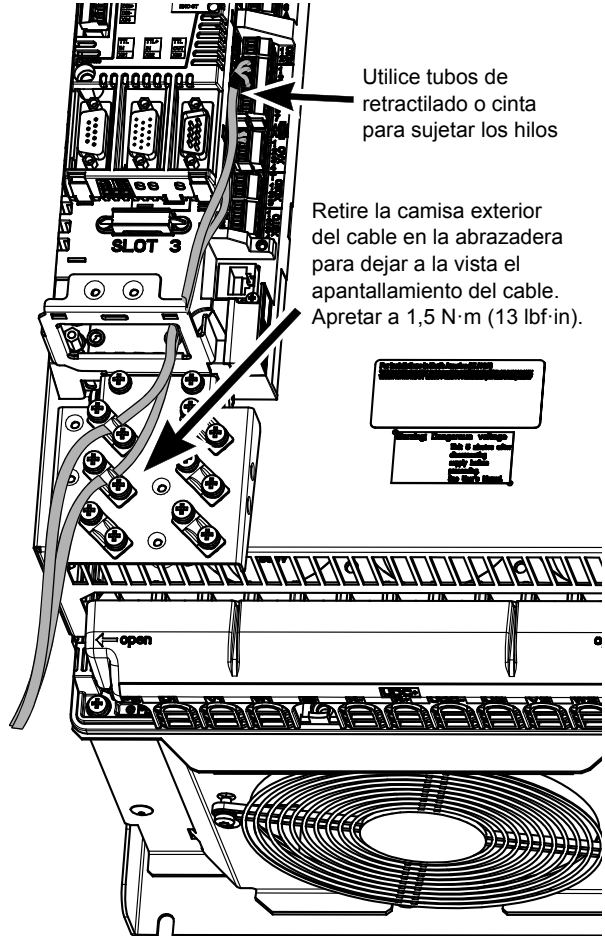

Utilice tubos de retráctilado o cinta para sujetar los hilos

Retire la camisa exterior del cable en la abrazadera para dejar a la vista el apantallamiento del cable. Apretar a 1,5 N·m (13 lbf·in).

Datos técnicos

Listado de comprobación UL

- El ACS850-04 es un convertidor de frecuencia con protección IP20 (UL tipo abierto) que deberá emplearse en interiores con ambiente controlado. El convertidor deberá ser instalado en una atmósfera limpia de conformidad con la clasificación del armario. El aire de refrigeración deberá estar limpio y libre de materiales corrosivos y de polvo conductor de electricidad. Consulte las especificaciones detalladas en el *Manual de Hardware*.
- La temperatura ambiente máxima es de 40 °C (104 °F) a intensidad nominal. Se produce derrateo a temperaturas de entre 40 y 55 °C (de 104 a 131 °F).
- El convertidor es apto para ser usado en circuitos que no proporcionen más de 100.000 amperios eficaces simétricos, 500 V como máximo.
- Los cables situados en el circuito del motor deben tener una especificación mínima de 75 °C (167 °F) en instalaciones realizadas conforme a la norma UL.
- El cable de entrada debe estar protegido mediante fusibles o interruptores automáticos. Se incluye una lista de fusibles IEC (clase gG) y UL (clase T) adecuados en la sección *Datos técnicos* del *Manual de Hardware*. Póngase en contacto con su representante local de ABB para informarse sobre los interruptores automáticos adecuados.
- Para instalación en los Estados Unidos, se deberá proporcionar la protección de circuitos derivados, de conformidad con el Código Eléctrico Nacional de EE. UU. (NEC) y con cualquier normativa local aplicable. Para cumplir este requisito, utilice fusibles con clasificación UL.
- Para instalación en Canadá, se deberá proporcionar la protección de circuitos derivados, de conformidad con el Código Eléctrico de Canadá y con cualquier normativa local

aplicable. Para cumplir este requisito, utilice fusibles con clasificación UL.

- El convertidor proporciona protección contra la sobrecarga de acuerdo con el Código Eléctrico Nacional de EE. UU. (NEC) Consulte el *Manual de Firmware* correspondiente para conocer los ajustes de la función de protección de sobrecarga.

Asennuksen pikaopas – ACS850-04

Johdanto

Tässä oppaassa on perustiedot ACS850-04-taajuusmuuttajamoduulin (55–200 kW) mekaanisesta asennuksesta ja sähköliitännöistä. Kattavat tiedot ovat *ACS850-04 Drive Modules (55–200 kW, 60–200 hv) Hardware Manual* -oppaassa, koodi: 3AUA0000045487 (englanninkielinen).

Turvaohjeet



VAROITUS! Taajuusmuuttajan sähköliitännät ja huoltotyöt saa suorittaa vain pätevä sähköalan ammattilainen.

Mitään taajuusmuuttajan, jarrukatkojan, moottorikaapelin tai moottorin asennustöitä ei saa tehdä, kun taajuusmuuttajaan on kytketty jännite. Taajuusmuuttajan jännitteettömyys tulee aina varmistaa mittaamalla.

Pyörivä kestopagneettimoottori voi synnyttää vaarallisen jännitteen. Moottorin akseli tulee lukita mekaanisesti, ennen kuin kestopagneettimoottori kytketään taajuusmuuttajaan ja ennen kuin kestopagneettimoottoriin kytketyn taajuusmuuttajan asennus- tai huoltotyö aloitetaan.

Mekaaninen asennus



VAROITUS! Jos taajuusmuuttaja kytketään IT-sähköjärjestelmään (maadoittamattomaan tai suurella [yli 30 ohmin] vastuksella maadoitettuun sähköjärjestelmään),

taajuusmuuttajan sisäinen EMC-suodatus tulee kytkeä irti. Tämä tulee tehdä ennen taajuusmuuttajan mekaanista asennusta. Lisäohjeita on *laiteoppaassa*.

Kiinnitä taajuusmuuttajamoduuli seinään neljällä ruuvilla.

Tehokaapeliliitännät

Kytchentäkaavio

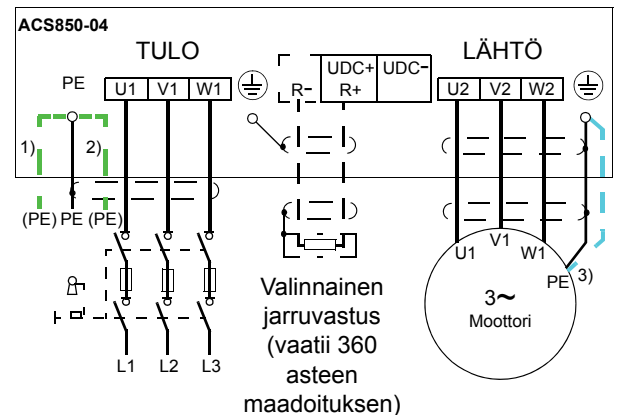

Huomaa:

- Käytä vain suojattua ja symmetristä moottorikaapelia. Myös syöttökaapelina (tulo) on hyvä käyttää suojattua kaapelia.
- Jos käytössä on suojattu syöttökaapeli (tulo) ja suojavaipan johtokyky on alle 50 % vaihejohtimen johtokyvystä, käytä maadoitusjohtimella varustettua kaapelia (1) tai erillistä PE-kaapelia (2).
- Moottorikaapelointiin tulee käyttää erillistä maadoituskaapelia (3), jos kaapelin suojavaipan johtokyky on alle 50 % vaihejohtimen johtokyvystä eikä kaapelissa ole symmetrisiä maadoitusjohtimia.

Jos moottorikaapelissa on johtavan suojavaipan lisäksi symmetrinen maadoitusjohdin, kytke maadoitusjohdin maadoitusliittimiin sekä taajuusmuuttajan että moottorin päässä.

Liitännän vaiheet

Jäljempänä on esimerkkejä kaapeliliitännöistä. Kiristysmomentit on esitetty sivulla 29 ja asiaankuuluviissa tekstikohtissa.

- Poista päaliittimien päällä oleva muovinen liitinsuoja. Nosta suojaa kulmasta ruuvimeisselillä.
- Liitä virtakaapeleiden kierretyt suojavaipat sekä erilliset maadoitusjohtimet taajuusmuuttajamoduulin maadoitusliittimiin.
- Liitä syöttökaapelin vaihejohtimet U1-, V1- ja W1-liittimiin ja moottorikaapelin vaihejohtimet U2-, V2- ja W2-liittimiin. Suositeltava kuorimispituus on 16 mm, kun runkokoko on E0, ja 28 mm, kun runkokoko on E.
- Kiinnitä taajuusmuuttajamoduulin ulkopuolella olevat kaapelin osat mekaanisesti.
- Leikkaa läpinäkyvään muoviseen kosketussuojaan aukot kaapeleita varten. Paina kosketussuoja liittimien suojaksi.
- Irrota tehokaapelien toinen pää. Varmista turvallisuus kiinnittämällä erityistä huomiota maadoitusjohtimien liitäntöihin.

Kaapelointiesimerkkejä

Runkokoko E0: Ruuviliitinasennus

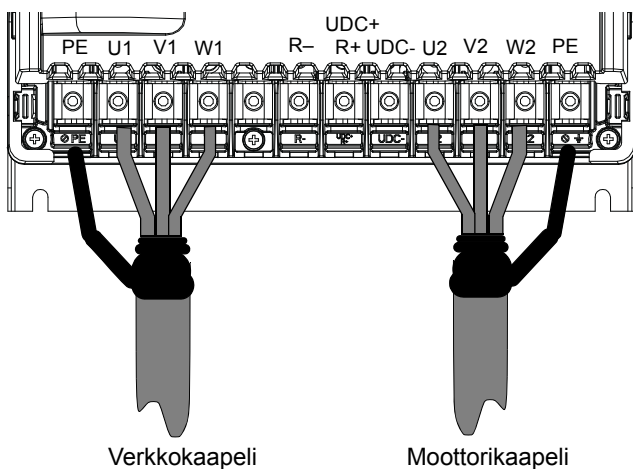

Runkokoko E: Kaapelikenkäsennus (kaapelin poikkipinta-ala 16–70 mm² [AWG6–AWG2/0])

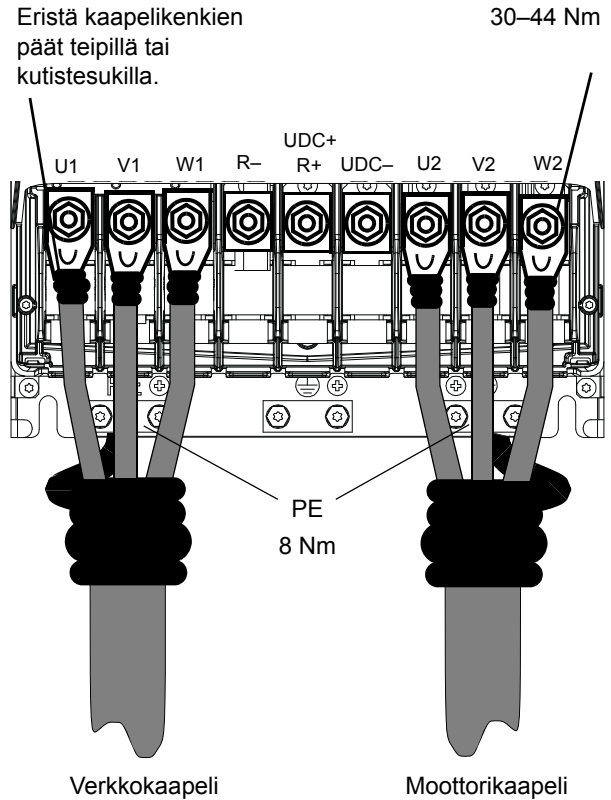

Runkokoko E: Ruuviliitinasennus (kaapelin poikkipinta-ala 95–240 mm² [AWG3/0–500MCM])

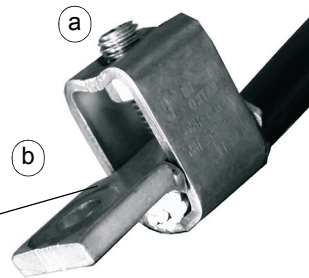
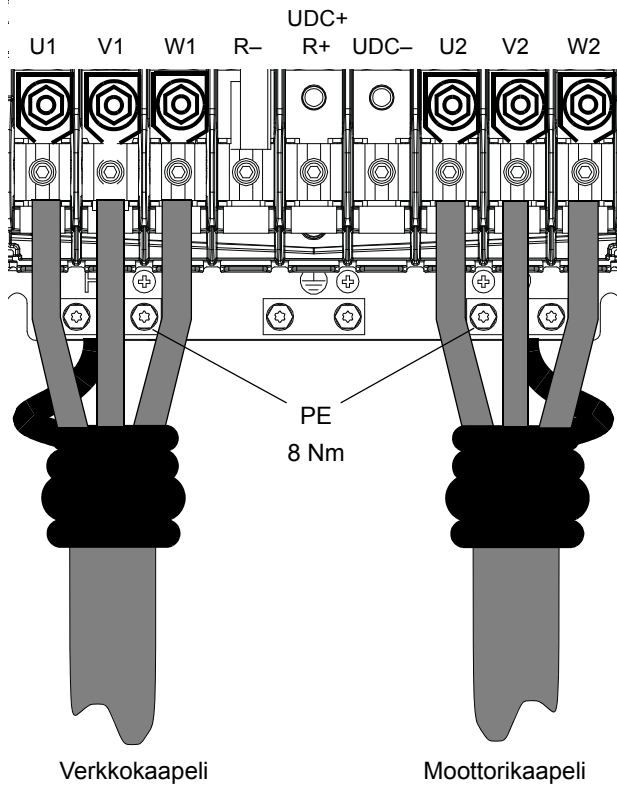

- a. Liitä kaapeli liittimeen. Kiristä kuusiokoloruuvi 20–40 Nm:n momenttiin.
- b. Liitä liitin taajuusmuuttajaan. Kiristä ruuvi 30–44 Nm:n momenttiin.



VAROITUS! Jos johdinkoko on alle 95 mm² (3/0 AWG), tulee käyttää puristusliitintä. Kaapeli, jonka liitinkoko on alle 95 mm² (3/0 AWG) ja joka on kytketty tähän liittimeen, löysistyy ja voi vahingoittaa taajuusmuuttajaa.

Teholiittimien hyväksytyt johdinkoot

Taajuusmuuttajan tyyppi ACS850-04-	Johtimen koko
-103A-5, -144A-5	6 – 70 mm ²
-166A-5...-290A-5	95 – 240 mm ²

Kiristysmomentit

Taajuusmuuttajan tyyppi ACS850-04-	Teholiittimet	
	Nm	PE Nm
-103A-5, -144A-5	15	15
-166A-5...-290A-5	Kaapelikenkäasennus 30–44	8
	Kuusiokoloruuvi 20–40 Ruuviliitinasennus 30–44	8

Ohjauskaapeleiden asennus

Oletusarvoiset I/O-ohjauskytkennät

Huomaa:

ACS850-vakio-ohjausohjelmiston oletusasetus (tehdasmakro).

*Suurin sallittu kokonaisvirta: 200 mA

Oheinen kytkentäkaavio on vain esimerkki.

Lisätietoja siirtoliittimien asennoista on oppaan tekstissä.

Johdinkoot ja kiristysmomentit:

XPOW, XRO1, XRO2, XRO3, XD24: 0,5 – 2,5 mm² (24–12 AWG). Momentti: 0,5 Nm

XDI, XDIO, XAI, XAO, XD2D, XSTO: 0,5 – 1,5 mm² (28–14 AWG). Momentti: 0,3 Nm

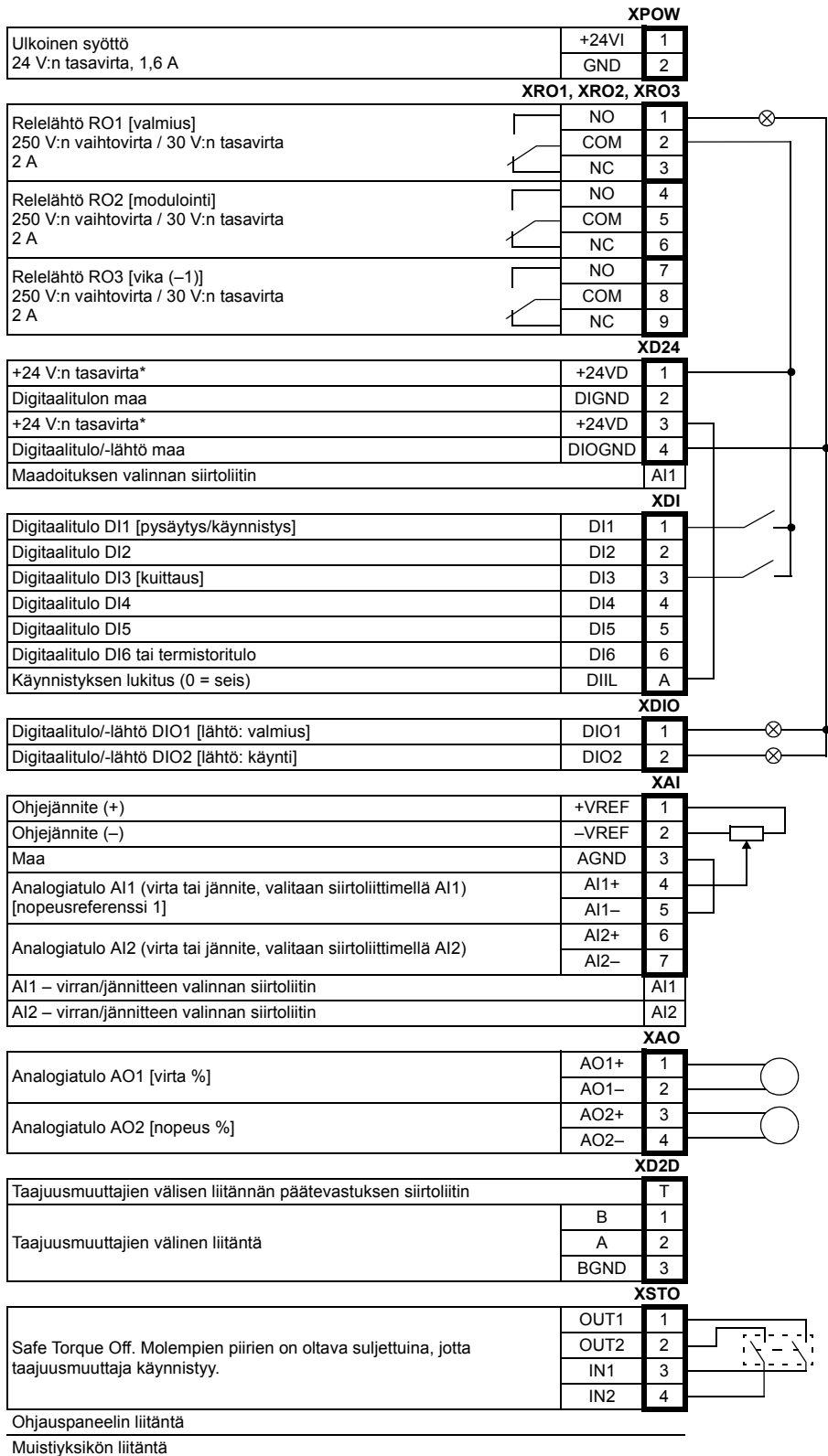
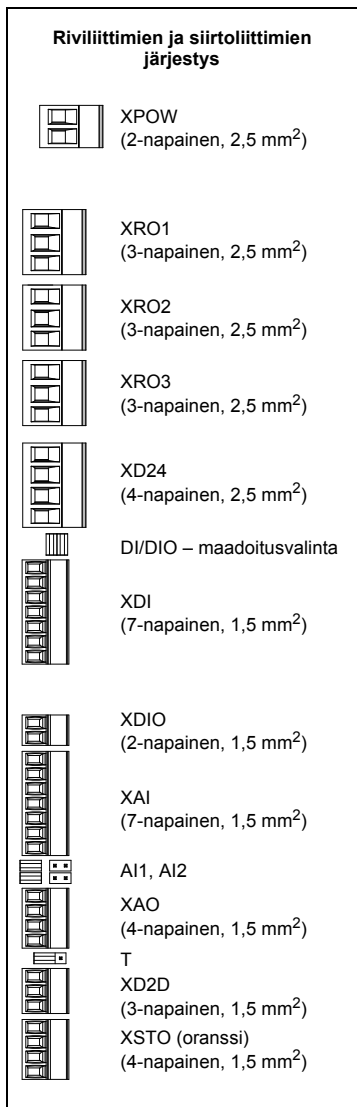

Ohjausyksikön siirtoliittimet: DI/DIO maadoitusvalitsin (XD24:n ja XDI:n välissä) – Määrittää onko DIGND (digitaalitulojen DI1–DI5 maadoitus) kelluva vai onko se kytketty DIOGND-liittimeen (maadoitus DI6-, DIO1- ja DIO2-liitäntöille). Jos DIGND on kelluva, digitaalitulojen DI1–DI5 yhteisen paluusignaalin tulee olla kytketty liitintään XD24:2. Paluusignaali voi olla joko GND tai V_{CC} , koska DI1–DI5 ovat tyyppiä NPN/PNP.

Kelluva DIGND DIGND kytketty DIOGND:hen

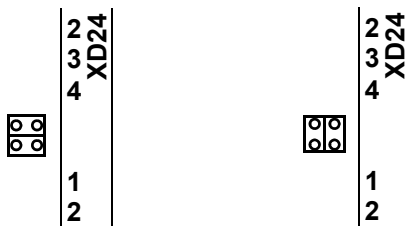

AI1 – Määrittää analogiatulon AI1 virta- tai jännitetuloksi.

Virta

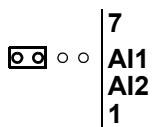

Jännite

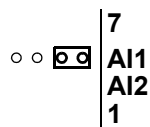

AI2 – Määrittää analogiatulon AI2 virta- tai jännitetuloksi.

Virta

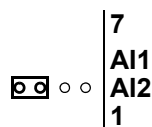

Jännite

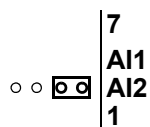

T – Taajuusmuuttajien välisen liitännän päätevastus. Täytyy olla ON-asennossa, kun taajuusmuuttaja on liitännän viimeinen yksikkö.

Päätevastus asennossa Päätevastus asennossa



Kiinnityslevyn kiinnittäminen

Kiinnityslevy, joka voidaan kiinnittää JCU-ohjausyksikön ylä- tai alaosaan.

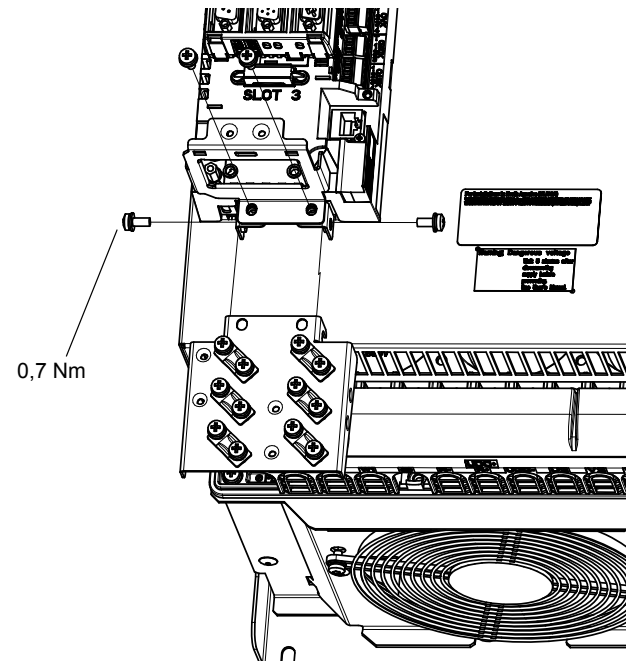

Jatka taajuusmuuttajan käyttöönottoa asianomaisen *pika-aloitusoppaan* ohjeiden mukaan.

Ohjauskaapeleiden reititys

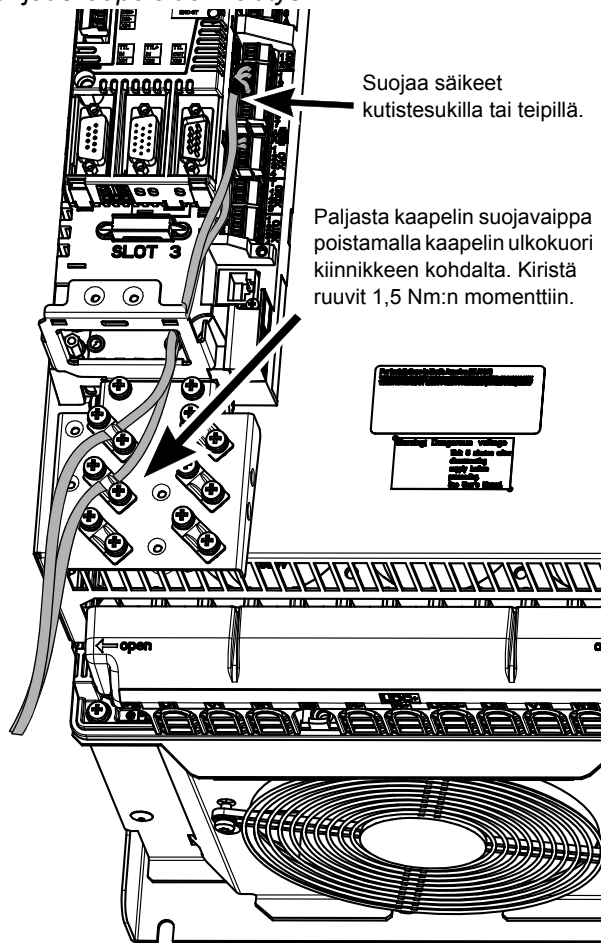

symmetrinen virta (rms), jonka jännite on enintään 500 V.

- Moottorikaapelit on mitoitettava vähintään 75 °C:n lämpötilaa varten UL-yhteensopivissa asennuksissa.
- Syöttökaapeli on suojattava sulakkeilla tai katkaisijoilla. Sopivat IEC-sulakkeet (luokka gG) ja UL-sulakkeet (luokka T) on lueteltu *laiteoppaan* kohdassa *Technical data*. Tietoa sopivista katkaisijoista saa ABB:n paikallisilta edustajilta.
- Jos laite asennetaan Yhdysvalloissa, haaroituskytkennän suojaus on tehtävä National Electrical Coden (NEC) ja muiden paikallisten säännösten mukaan. Tämä vaatimus täyttyy UL-hyväksytyjä sulakkeita käytettäessä.
- Jos laite asennetaan Kanadassa, haaroituskytkennän suojaus on tehtävä Canadian Electrical Coden ja muiden paikallisten säännösten mukaan. Tämä vaatimus täyttyy UL-hyväksytyjä sulakkeita käytettäessä.
- Taajuusmuuttajassa on National Electrical Coden (NEC) mukainen ylikuormitussuojaus. Lisätietoja ylikuormitussuojauksen asetuksista on asianomaisessa *ohjelmointioppaassa*.

Tekniset tiedot

UL-tarkistuslista

- ACS850-04 on suojausluokan IP20 (UL avoin) taajuusmuuttaja, joka on suunniteltu käytettäväksi lämmitetyissä sisätiloissa valvotuissa olosuhteissa. Taajuusmuuttajan koteloituusluokka määrittelee asennuspaikan ilman puhtauden. Jäähdytysilman on oltava puhdasta, eikä siinä saa esiintyä syövyttäviä aineita tai sähköä johtavaa pölyä. Lisätietoja on *laiteoppaassa*.
- Käyttöympäristön ilman maksimilämpötila on 40 °C nimellisvirralla. Laitteen kuormitettavuus pienenee 40–55 °C:ssa.
- Taajuusmuuttaja sopii käytettäväksi piireissä, joissa kulkee enintään 100 000 ampeerin

Guide d'installation rapide – ACS850-04

Introduction

Ce guide reprend l'essentiel des consignes de montage et de raccordement du module variateur ACS850-04 (55 à 200 kW). Pour une description complète, cf. *Manuel d'installation ACS850-04 (55 à 200 kW, 60 à 200 hp)* (code : 3AUA0000071008).

Consignes de sécurité



ATTENTION ! Seuls des électriciens qualifiés sont autorisés à procéder à l'installation et à la maintenance du variateur.

N'intervenez jamais sur le variateur, le circuit du hacheur de freinage, le câble moteur ou le moteur lorsque le variateur est sous tension. Vous devez toujours vérifier l'absence effective de tension par une mesure.

Un moteur à aimants permanents en rotation peut générer une tension dangereuse. Bloquez mécaniquement l'arbre du moteur avant de le raccorder au variateur et avant toute intervention sur un variateur connecté à un moteur à aimants permanents.

Montage



ATTENTION ! Si le variateur est raccordé à un réseau en schéma IT (neutre isolé ou impédant [plus de 30 ohm]), vous devez retirer la vis du filtre RFI avant de monter l'appareil.

Cf. *Manuel d'installation* pour des détails.

Fixez le module variateur au mur avec les quatre vis.

Câbles de puissance

Schéma de raccordement

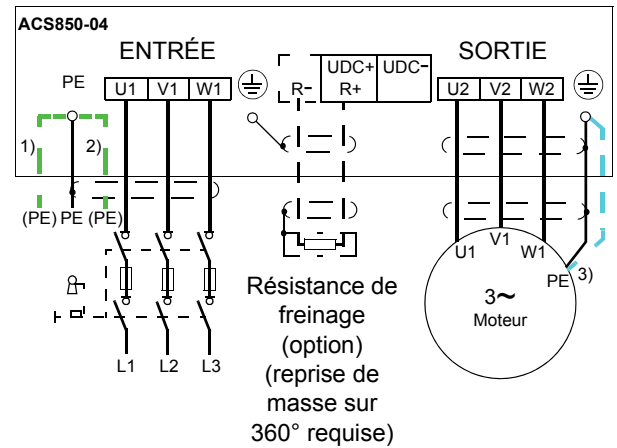

N.B. :

- N'utilisez pas de câble non blindé ou à conducteurs asymétriques. ABB vous recommande également d'utiliser un câble réseau (alimentation) blindé.
- Si un câble réseau blindé est utilisé et que la conductivité du blindage est inférieure à 50 % de celle d'un conducteur de phase, utilisez un câble avec conducteur de terre (1) ou un câble PE séparé (2).
- Pour le câblage du moteur, utilisez un câble de terre séparé (3) si la conductivité du blindage de câble est inférieure à 50 % de celle d'un conducteur de phase et que le câble n'a pas de conducteur de terre symétrique.

Si le câble moteur comporte, en plus du blindage conducteur, un conducteur de terre symétrique, vous devez raccorder le conducteur de terre à la borne de terre côté variateur et côté moteur.

Procédure de raccordement

Des exemples de raccordement sont présentés ci-dessous. Les couples de serrage sont indiqués page 35 et aux passages pertinents du texte.

- Retirez la protection en plastique qui recouvre les bornes principales. Utilisez un tournevis pour la soulever par un coin.
- Connectez les blindages torsadés des câbles d'alimentation et les conducteurs de terre séparés aux bornes de terre du variateur.
- Connectez les conducteurs de phase du câble réseau aux bornes U1, V1 et W1, et les conducteurs de phase du câble moteur aux bornes U2, V2 et W2. La longueur recommandée pour le dénudage est de 16 mm (0.63") pour la taille E0 et de 28 mm (1.1") pour la taille E.
- Fixez les câbles mécaniquement à l'extérieur du variateur.
- Dans le protecteur (cache-bornes) de plastique transparent, percez les trous adéquats pour y faire passer les câbles de puissance. Placez le protecteur sur les bornes.
- Connectez l'autre extrémité des câbles de puissance. Vous devez prêter spécialement attention au raccordement des conducteurs de terre pour des raisons de sécurité.

Exemples de raccordement

Taille E0 : Installation de la borne à vis

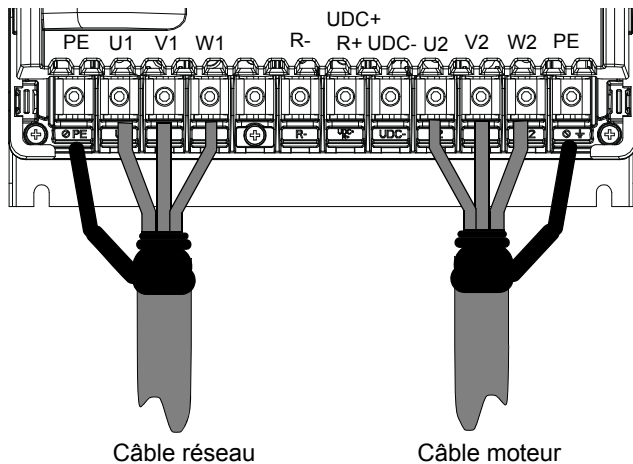

Taille E : Installation de la cosse de câble (câbles de 16 à 70 mm² [AWG6 à AWG2/0])

Isoler les extrémités des cosses de câble avec une gaine rétractable ou un ruban.

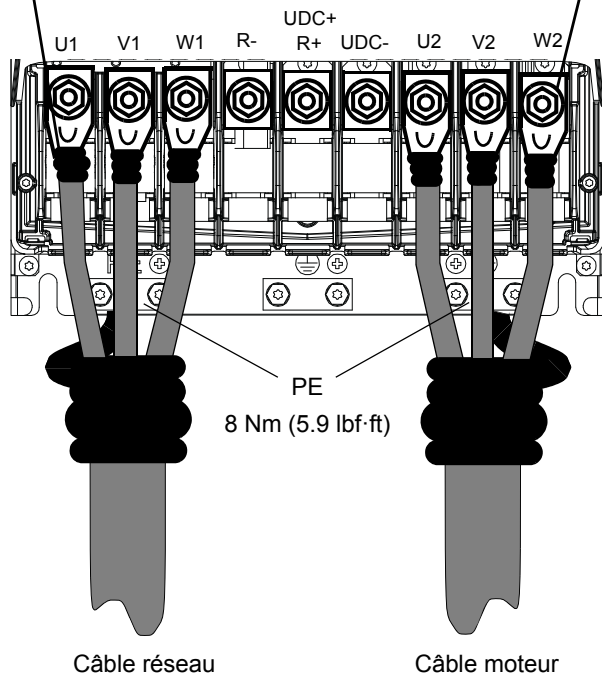

Taille E : Installation de la borne à vis (câbles de 95 à 240 mm² [AWG3/0 à 500MCM])

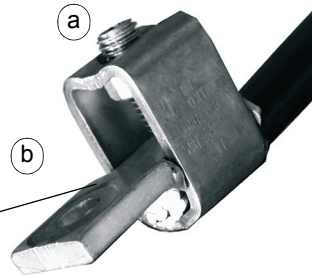
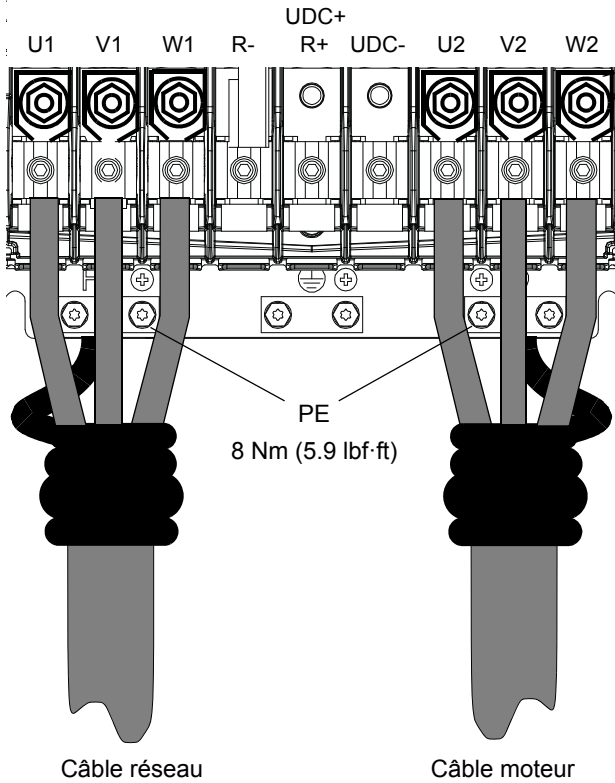

- a. Connectez le câble à la borne. Serrez la vis Allen à 20...40 Nm (15...30 lbf-ft).
- b. Raccordez la borne au variateur. Serrez à 30...44 Nm (22...32 lbf-ft).



ATTENTION ! Si la taille du câble est inférieure à 95 mm² (3/0 AWG), une cosse à sertir doit être utilisée. Un câble d'une taille inférieure à 95 mm² (3/0 AWG) connecté à cette borne se desserrera et peut endommager le variateur.

Sections des fils pour les bornes de puissance

Type d'ACS850-04...	Section des fils
-103A-5, -144A-5	6 ... 70 mm ²
-166A-5...-290A-5	95 ... 240 mm ²

Couples de serrage

Type d'ACS850-04...	Bornes de puissance	PE
	Nm (lbf-ft)	Nm (lbf-ft)
-103A-5, -144A-5	15 (11)	15 (11)
-166A-5...-290A-5	Installation de la cosse de câble 30...44 (22...32)	8 (5.9)
	Vis Allen 20...40 (15...30) Installation de la borne à vis 30...44 (22...32)	8 (5.9)

Câbles de commande

Schéma de raccordement des signaux d'E/S (préréglages)

N.B. :
 [Préréglages du programme de commande Standard ACS850 (macroprogramme Usine).

*Courant maxi total : 200 mA

Schéma de câblage illustré uniquement à titre d'exemple.

Pour le réglage des cavaliers, cf. texte.

Section des fils et couples de serrage :

XPOW, XRO1, XRO2, XRO3, XD24 :
 0,5 ... 2,5 mm² (24...12 AWG). Couple : 0,5 Nm (5 lbf-in)

XDI, XDIO, XAI, XAO, XD2D, XSTO :
 0,5 ... 1,5 mm² (28...14 AWG). Couple : 0,3 Nm (3 lbf-in)

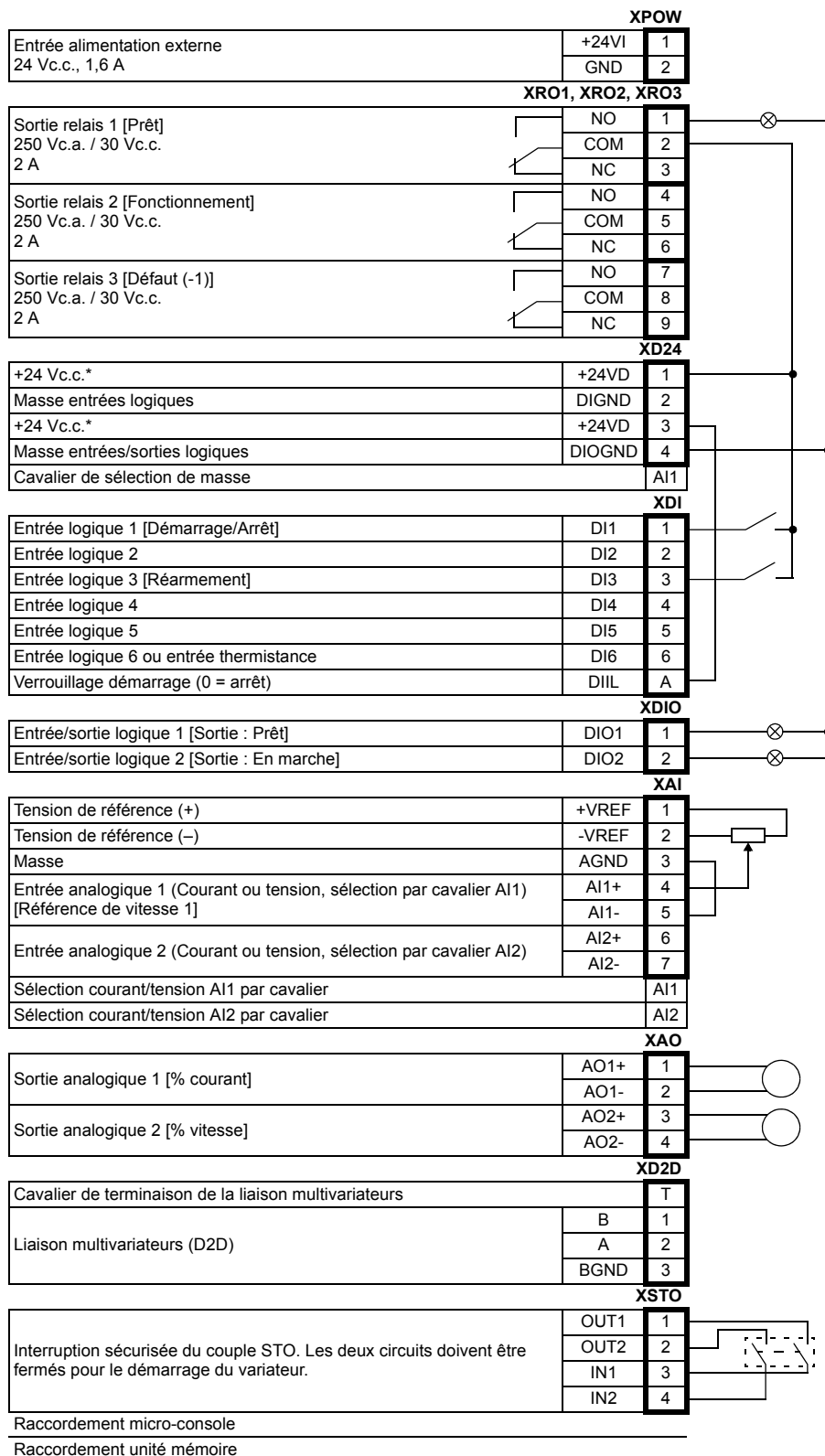
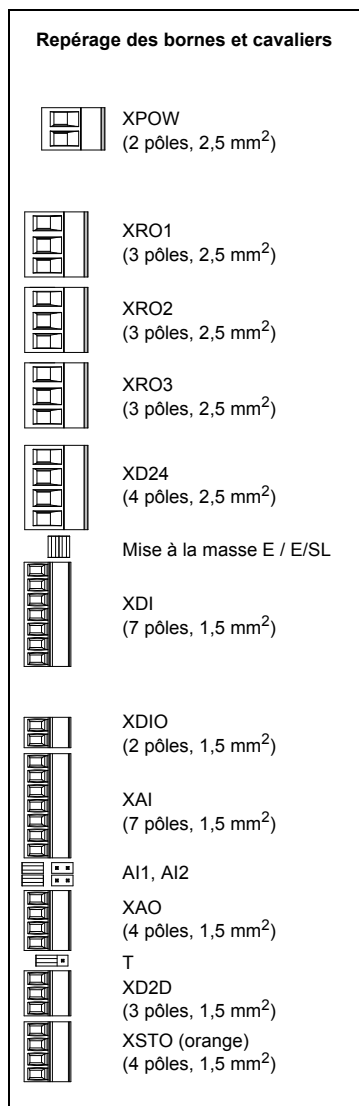

Cavaliers sur l'unité de commande :

Cavalier de sélection de la masse pour les entrées et les entrées/sorties logiques (cavalier situé entre XD24 et XD1) : réglage de l'état de DIGND (masse des entrées logiques DI1 à DI5) par rapport à DIOGND (masse de DI6, DIO1 et DIO2).

DIGND flottante ou raccordée sur DIOGND : si DIGND est flottante, raccordez le commun de DI1... DI5 sur XD24:2. Le commun est soit GND soit V_{CC} car DI1...DI5 sont de type NPN/ PNP.

DIGND flottante DIGND raccordée sur DIOGND

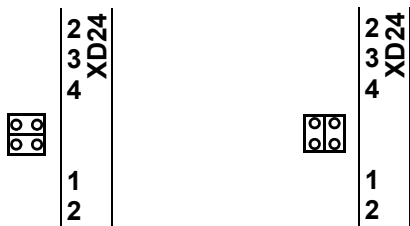

AI1 – Sélection du signal sur l'entrée analogique AI1 : courant ou tension.

Courant Tension



AI2 – Sélection du signal sur l'entrée analogique AI2 : courant ou tension.

Courant Tension



T – Terminaison de liaison multivariateurs.
Réglez sur ON si le variateur est le dernier de la liaison.

Terminaison ON Terminaison OFF



Procédez à la mise en route du variateur conformément aux instructions du document anglais *Quick Start-up Guide* correspondant.

Montage de la plaque serre-câbles

La plaque serre-câbles peut être fixée sur le haut ou le bas de l'unité de commande JCU.

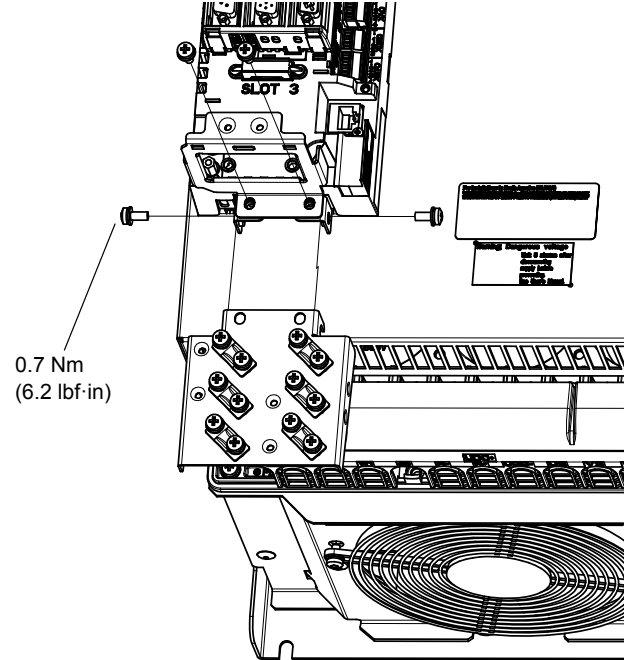

Cheminement des câbles de commande

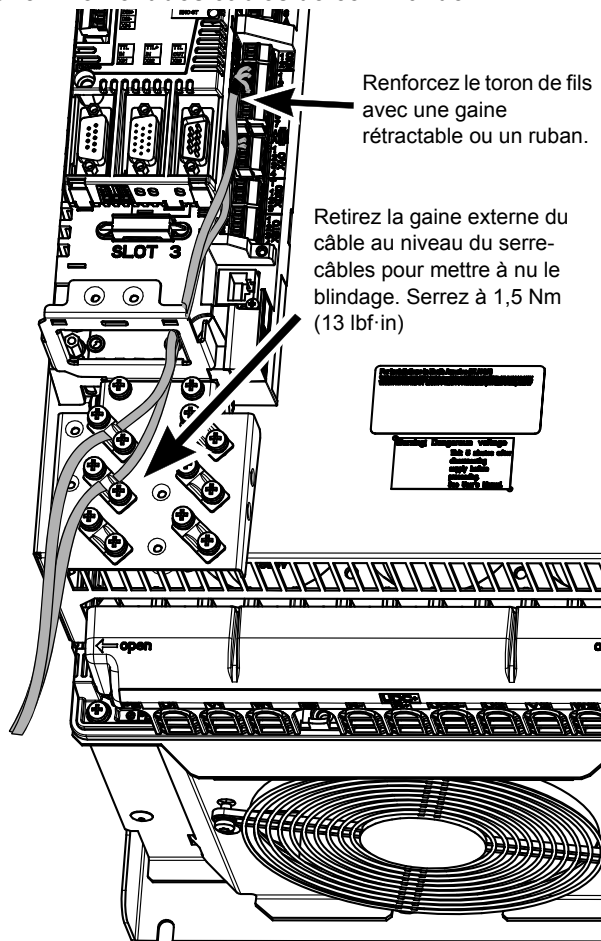

- Les câbles situés dans le circuit moteur doivent résister au moins à 75 °C (167 °F) dans des installations conformes UL.
- Le câble réseau doit être protégé par des fusibles ou des disjoncteurs. Pour le calibre des fusibles CEI (classe gG) et UL (classe T), cf. chapitre *Caractéristiques techniques* du *Manuel d'installation*. Pour le calibre des disjoncteurs, contactez votre correspondant ABB.
- Installation aux États-Unis : une protection de dérivation conforme NEC (National Electrical Code) et autres réglementations en vigueur doit être prévue. Pour la conformité, utilisez des fusibles homologués UL.
- Installation au Canada : une protection de dérivation conforme CEC (Code électrique canadien) et autres réglementations provinciales en vigueur doit être prévue. Pour la conformité, utilisez des fusibles homologués UL.
- Le variateur assure une protection contre les surcharges conforme NEC (National Electrical Code). Cf. *Manuel d'exploitation* correspondant pour le réglage des protections contre les surcharges.

Caractéristiques techniques

Éléments du marquage UL

- Le variateur ACS850-04 est protégé IP20 (UL type ouvert). Il doit être installé dans un local chauffé, fermé et à environnement contrôlé conforme au degré de protection. L'air de refroidissement doit être propre, exempt d'agents corrosifs et de poussières conductrices. Cf. *Manuel d'installation* pour les spécifications détaillées.
- La température maximale de l'air ambiant est 40 °C (104 °F) à courant nominal. Il y a déclassement du courant entre 40 et 55 °C (104 et 131 °F).
- Le variateur peut être utilisé sur un réseau capable de fournir pas plus de 100 kA efficaces symétriques et 500 V.

Guida rapida all'installazione – ACS850-04

Informazioni sulla guida

Questa guida contiene le informazioni di base per l'installazione meccanica ed elettrica del modulo convertitore ACS850-04 (55...200 kW). Per la documentazione completa, vedere il *Manuale hardware dei moduli convertitore ACS850-04 (55...200 kW, 60...200 hp)* (cod. 3AUA0000045487 [inglese]).

Norme di sicurezza



AVVERTENZA! L'installazione elettrica e gli interventi di manutenzione sul convertitore di frequenza devono essere eseguiti esclusivamente da elettricisti qualificati.

Non intervenire mai sul convertitore, sul circuito del chopper di frenatura, sul cavo motore o sul motore quando il convertitore è sotto tensione. Verificare sempre che non sia presente tensione.

Un motore a magneti permanenti in rotazione può generare una tensione pericolosa. Bloccare meccanicamente l'albero del motore prima di collegare un motore a magneti permanenti al convertitore di frequenza e prima di effettuare qualsiasi intervento su un azionamento collegato a un motore a magneti permanenti.

Installazione meccanica



AVVERTENZA! Se il convertitore di frequenza viene installato in un sistema IT (un sistema di alimentazione senza messa a terra o con messa a terra ad alta resistenza [superiore a 30 ohm]), è necessario scollegare il filtro EMC interno. Questa operazione deve essere effettuata prima di eseguire l'installazione meccanica del convertitore. Per le istruzioni dettagliate, vedere il *Manuale hardware*.

Fissare il modulo convertitore alla parete con quattro viti.

Installazione dei cavi di potenza

Schema di collegamento

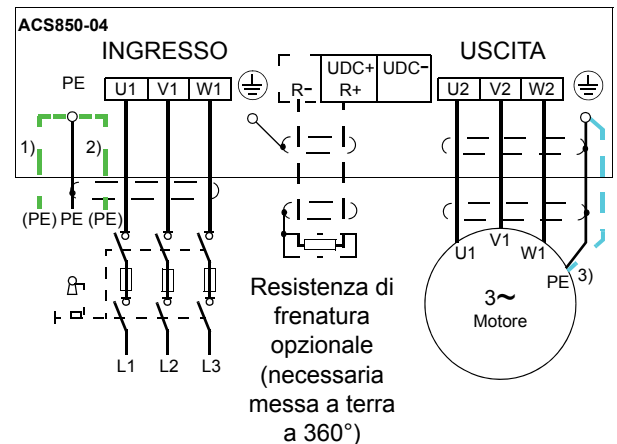

Note:

- Non utilizzare un cavo motore non schermato o con struttura asimmetrica. Si raccomanda di utilizzare un cavo schermato anche per l'alimentazione di ingresso.
- Se il cavo di alimentazione è schermato e la conduttività della schermatura è inferiore al 50% della conduttività di un conduttore di fase, utilizzare un cavo con un conduttore di terra (1) o un cavo PE separato (2).
- Per il cablaggio del motore, utilizzare un cavo di terra separato (3) se la conduttività della schermatura del cavo è inferiore al 50% della conduttività di un conduttore di fase e il cavo non è dotato di conduttori di terra simmetrici.

Se nel cavo del motore è presente un conduttore di terra simmetrico in aggiunta alla schermatura conduttiva, collegarlo ai morsetti di terra lato convertitore e lato motore.

Procedura di collegamento

Di seguito sono illustrati alcuni esempi di cablaggio. Le coppie di serraggio sono indicate a pag. 41 e in vari punti all'interno del testo.

- Rimuovere la protezione in plastica che copre i morsetti di alimentazione, sollevandola da un angolo con un cacciavite.
- Collegare le schermature intrecciate dei cavi di alimentazione e i conduttori di terra separati ai morsetti di terra del modulo convertitore.
- Collegare i conduttori di fase del cavo di alimentazione ai morsetti U1, V1 e W1 e i conduttori di fase del cavo del motore ai morsetti U2, V2 e W2. La lunghezza di spellatura raccomandata è 16 mm (0.63") per il telaio E0 e 28 mm (1.1") per il telaio E.
- Fissare i cavi meccanicamente all'esterno del modulo convertitore.
- Praticare dei fori nella protezione in plastica trasparente per far passare i cavi di alimentazione. Applicare la protezione sui morsetti mediante pressione.
- Collegare le altre estremità dei cavi di alimentazione. Per garantire la sicurezza, prestare particolare attenzione al collegamento dei conduttori di terra.

Esempi di cablaggio

Telaio E0: installazione dei morsetti a vite

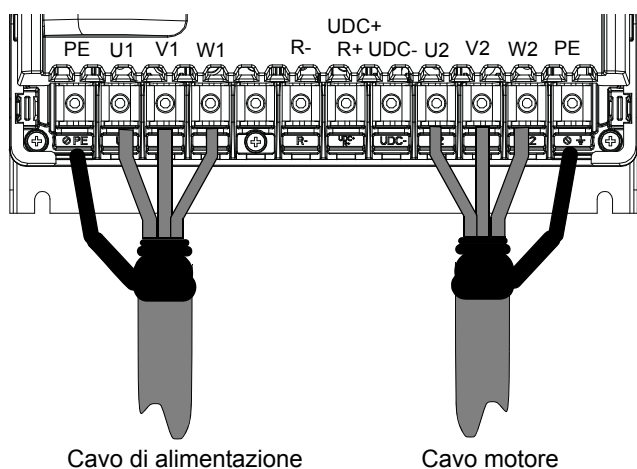

Telaio E: installazione dei capicorda (cavi da 16 a 70 mm² [da 6 a 2/0 AWG])

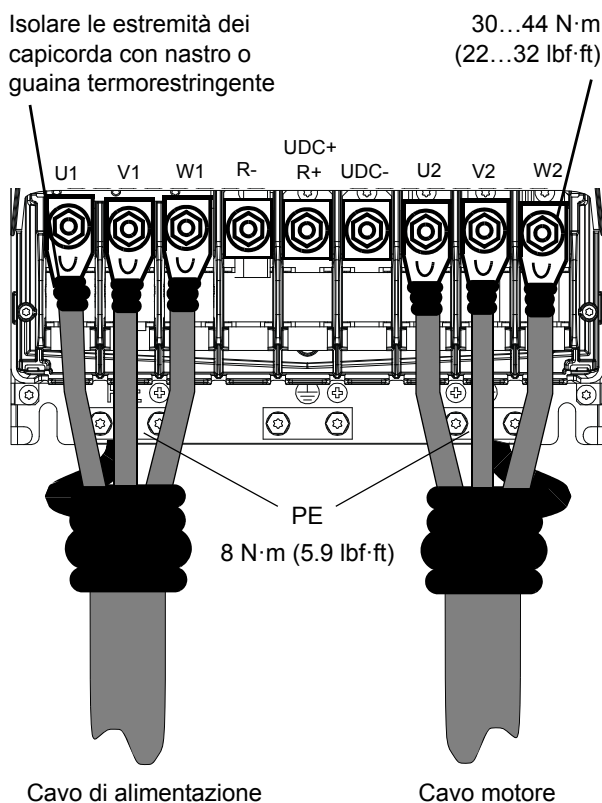

Telaio E: installazione dei morsetti a vite (cavi da 95 a 240 mm² [da 3/0 AWG a 500 MCM])

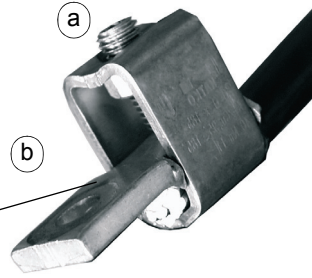
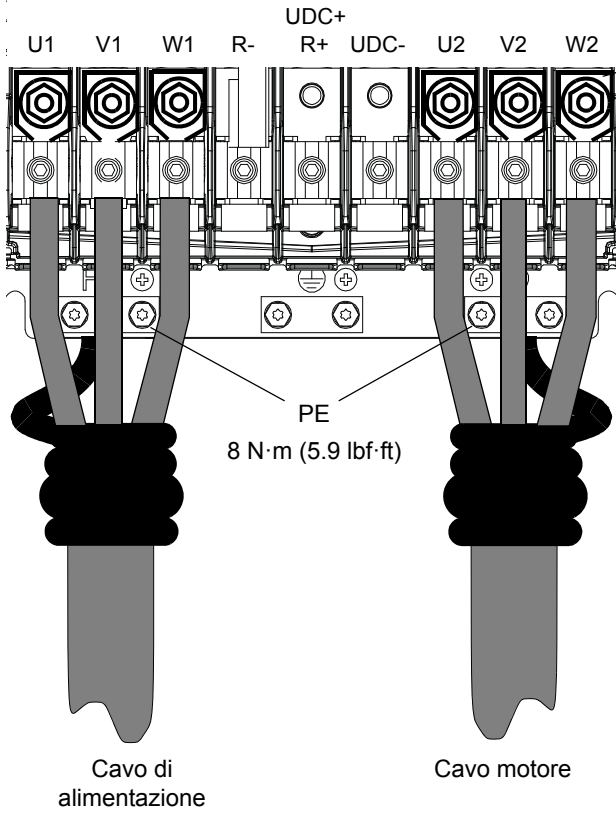

- a. Collegare il cavo al morsetto. Serrare la vite a brugola applicando una coppia di 20...40 N·m (15...30 lbf·ft).
- b. Collegare il morsetto al convertitore. Serrare applicando una coppia di 30...44 N·m (22...32 lbf·ft).



AVVERTENZA! Se la sezione del cavo è minore di 95 mm² (3/0 AWG), è necessario utilizzare un connettore crimpato. Se un cavo di dimensioni inferiori a 95 mm² (3/0 AWG) viene collegato a questo morsetto senza capocorda, rischia di allentarsi e di danneggiare il convertitore di frequenza.

Dimensioni dei fili compatibili con i morsetti di potenza

Convertitore ACS850-04...	Dimensioni filo
-103A-5, -144A-5	6 ... 70 mm ²
-166A-5...-290A-5	95 ... 240 mm ²

Coppie di serraggio

Convertitore ACS850-04...	Morsetti di potenza	PE
	N·m (lbf·ft)	N·m (lbf·ft)
-103A-5, -144A-5	15 (11)	15 (11)
-166A-5...-290A-5	Installazione capicorda 30...44 (22...32)	8 (5.9)
	Vite a brugola 20...40 (15...30) Installazione morsetti a vite 30...44 (22...32)	8 (5.9)

Installazione dei cavi di controllo

Schema dei collegamenti degli I/O di default

Note:

[Impostazione di default con il Programma di controllo standard dell'ACS850 (macro Fabbrica).

*Corrente totale massima: 200 mA

Il cablaggio illustrato ha esclusivo scopo dimostrativo.

Per le impostazioni dei ponticelli, vedere il testo.

Dimensioni fili e coppie di serraggio:

XPOW, XRO1, XRO2, XRO3, XD24:
0,5 ... 2,5 mm² (24...12 AWG). Coppia: 0,5 N·m (5 lbf·in)

XDI, XDIO, XAI, XAO, XD2D, XSTO:
0,5 ... 1,5 mm² (28...14 AWG). Coppia: 0,3 N·m (3 lbf·in)

Ordine di testate morsetti e ponticelli

XPOW		
Ingresso potenza esterna 24 Vcc, 1,6 A	+24VI	1
	GND	2

XRO1, XRO2, XRO3		
Uscita relè RO1 [Pronto] 250 Vca / 30 Vcc 2 A	NO	1
	COM	2
	NC	3
Uscita relè RO2 [Modulazione] 250 Vca / 30 Vcc 2 A	NO	4
	COM	5
	NC	6
Uscita relè RO3 [Guasto(-1)] 250 Vca / 30 Vcc 2 A	NO	7
	COM	8
	NC	9

XD24		
+24 Vcc*	+24VD	1
Terra ingressi digitali	DIGND	2
+24 Vcc*	+24VD	3
Terra ingressi/uscite digitali	DIOGND	4
Ponticello selezione terra	AI1	

XDI		
Ingresso digitale DI1 [Arresto/Marcia]	DI1	1
Ingresso digitale DI2	DI2	2
Ingresso digitale DI3 [Reset]	DI3	3
Ingresso digitale DI4	DI4	4
Ingresso digitale DI5	DI5	5
Ingresso digitale DI6 o ingresso termistore	DI6	6
Interblocco marcia (0 = arresto)	DIIL	A

XDIO		
Ingresso/uscita digitale DIO1 [Uscita: pronto]	DIO1	1
Ingresso/uscita digitale DIO2 [Uscita: in marcia]	DIO2	2

XAI		
Tensione di riferimento (+)	+VREF	1
Tensione di riferimento (-)	-VREF	2
Terra	AGND	3
Ingresso analogico AI1 (corrente o tensione, selezionabile con ponticello AI1) [Riferimento velocità 1]	AI1+	4
	AI1-	5
Ingresso analogico AI2 (corrente o tensione, selezionabile con ponticello AI2)	AI2+	6
	AI2-	7
Ponticello selezione corrente/tensione ingr. analogico AI1	AI1	
Ponticello selezione corrente/tensione ingr. analogico AI2	AI2	

XAO		
Uscita analogica AO1 [Corrente %]	AO1+	1
	AO1-	2
Uscita analogica AO2 [Velocità %]	AO2+	3
	AO2-	4

XD2D		
Ponticello terminazione collegamento drive-to-drive	B	1
	A	2
	BGND	3

XSTO		
Safe Torque Off. Per avviare il convertitore entrambi i circuiti devono essere chiusi.	OUT1	1
	OUT2	2
	IN1	3
	IN2	4

Collegamento pannello di controllo		
Collegamento unità di memoria		

Ponticelli sull'unità di controllo: selettore di messa a terra DI/DIO (situato tra XD24 e XDI)
 – Determina se DIGND (terra per gli ingressi digitali DI1...DI5) è flottante oppure è collegato a DIOGND (terra per DI6, DIO1 e DIO2). Se DIGND è flottante, il comune degli ingressi digitali DI1...DI5 va collegato a XD24:2. Il comune può essere GND o V_{cc} dato che DI1...DI5 sono di tipo NPN/PNP.

DIGND flottante DIGND collegato a DIOGND

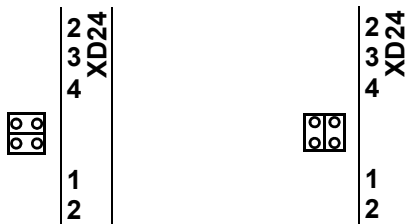

AI1 – Determina se l'ingresso analogico AI1 viene utilizzato come ingresso di corrente o di tensione.

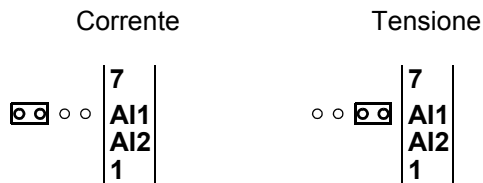

AI2 – Determina se l'ingresso analogico AI2 viene utilizzato come ingresso di corrente o di tensione.

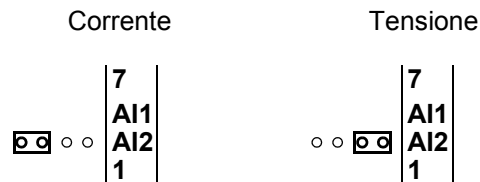

T – Terminazione del collegamento drive-to-drive. Deve essere impostato su ON quando il convertitore di frequenza è l'ultima unità sul collegamento.

Terminazione ON Terminazione OFF



Continuare l'avviamento del convertitore seguendo le istruzioni contenute nella relativa *Guida rapida all'avviamento*.

Montaggio della piastra fissacavi

La piastra fissacavi può essere fissata alla parte superiore o inferiore dell'unità di controllo JCU.

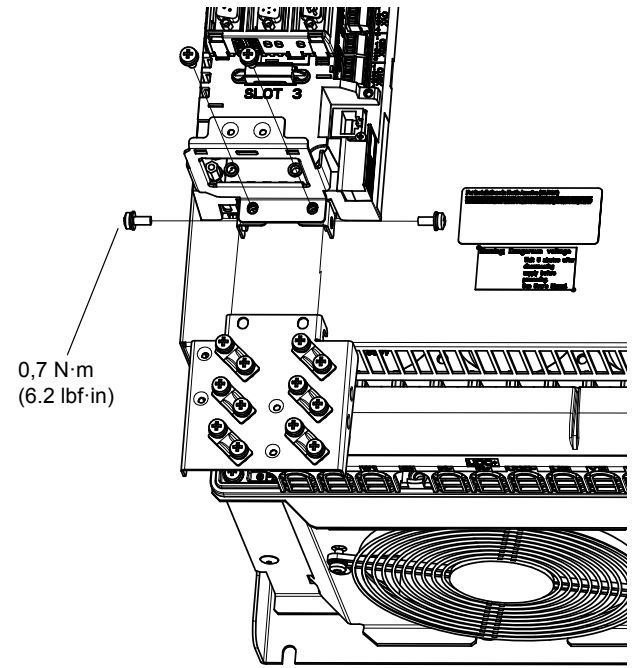

Posa dei cavi di controllo

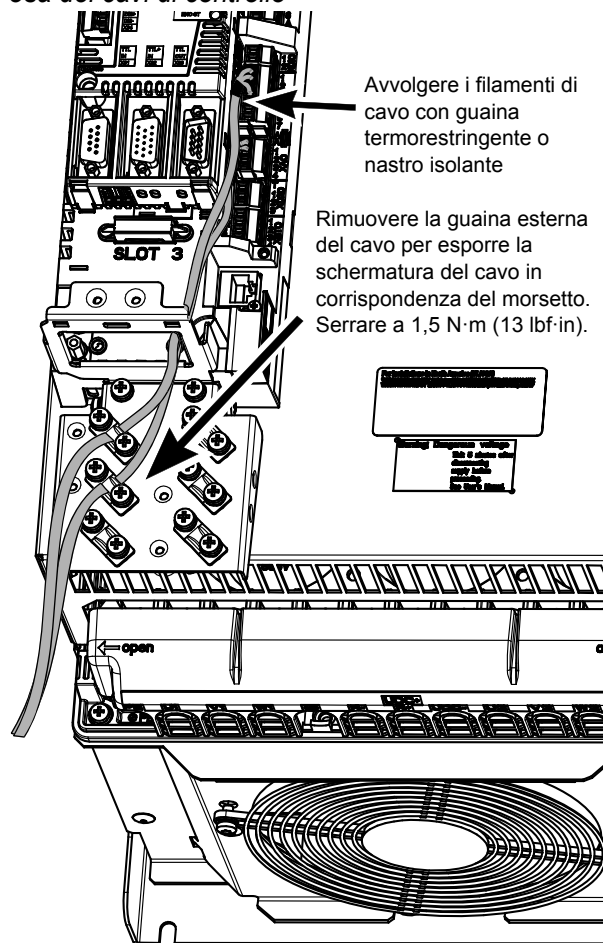

Avvolgere i filamenti di cavo con guaina termorestringente o nastro isolante

Rimuovere la guaina esterna del cavo per esporre la schermatura del cavo in corrispondenza del morsetto. Serrare a 1,5 N·m (13 lbf-in).

- Il convertitore è idoneo per essere utilizzato su circuiti in grado di produrre non oltre 100.000 RMS ampere simmetrici, massimo 500 V.
- I cavi situati all'interno del circuito del motore devono essere approvati almeno per 75 °C (167 °F) in installazioni conformi a UL.
- Il cavo di ingresso deve essere protetto con fusibili o interruttori automatici. I fusibili idonei IEC (classe gG) e UL (classe T) sono elencati nella sezione *Dati tecnici* del *Manuale hardware*. Per gli interruttori automatici idonei, contattare il rappresentante ABB locale.
- Per l'installazione negli Stati Uniti, la protezione dei circuiti di derivazione deve essere conforme al National Electrical Code (NEC) e alle normative locali applicabili. Per soddisfare questo requisito, utilizzare fusibili classificati UL.
- Per l'installazione in Canada, la protezione dei circuiti di derivazione deve essere conforme al Canadian Electrical Code e alle normative locali applicabili. Per soddisfare questo requisito, utilizzare fusibili classificati UL.
- Il convertitore di frequenza fornisce la protezione da sovraccarico in conformità al National Electrical Code (NEC). Per le impostazioni della protezione da sovraccarico, vedere il *Manuale firmware*.

Dati tecnici

Checklist UL

- L'ACS850-04 è un convertitore di frequenza IP20 (UL tipo aperto) che va utilizzato in ambienti chiusi, riscaldati e controllati. Il convertitore deve essere installato in un luogo con aria pulita secondo la classificazione dell'armadio. L'aria di raffreddamento deve essere pulita, priva di materiali corrosivi e di polveri elettricamente conduttive. Per le specifiche dettagliate, vedere il *Manuale hardware*.
- La temperatura massima dell'aria ambiente è di 40 °C (104 °F) alla corrente nominale. La corrente viene declassata per temperature comprese tra 40 e 55 °C (104-131 °F).

Beknopte installatiegids – ACS850-04

Inleiding

Deze gids bevat de basis-informatie over de mechanische en elektrische installatie van de omvormermodule ACS850-04 (55 tot 200 kW). Zie voor de volledige documentatie *ACS850-04 Drive Modules (55...200 kW, 60...200 hp) Hardware Manual* (code: 3AUA0000045487 [Engels]).

Veiligheidsvoorschriften



WAARSCHUWING! Alle werkzaamheden wat betreft elektrische installatie en onderhoud van de omvormer mogen alleen door gekwalificeerde elektriciens uitgevoerd worden.

Voer nooit werkzaamheden uit aan de omvormer, het remchoppercircuit, de motorkabel of de motor wanneer de omvormer onder spanning staat. Verzekert u er altijd van dat er geen spanning aanwezig is door meting.

Een draaiende permanentmagneetmotor kan een gevaarlijke spanning genereren. Vergrendel de motoras mechanisch alvorens een permanentmagneetmotor op de omvormer aan te sluiten, en alvorens werkzaamheden uit te voeren aan een omvormersysteem waarop een permanentmagneetmotor aangesloten is.

Mechanische installatie



WAARSCHUWING! Als de omvormer aangesloten gaat worden op een IT-vermogensysteem (d.w.z. een niet-geaard vermogenssysteem of een hoogohmig geaard vermogenssysteem [meer dan 30 ohm]), moet het interne EMC-filter van de omvormer losgekoppeld worden. Dit dient te gebeuren vóórdat de omvormer mechanisch geïnstalleerd wordt. Zie de *Hardware handleiding* voor nadere instructies.

Bevestig de omvormermodule met vier schroeven aan de wand.

Installeren van de vermogenskabels

Aansluitschema

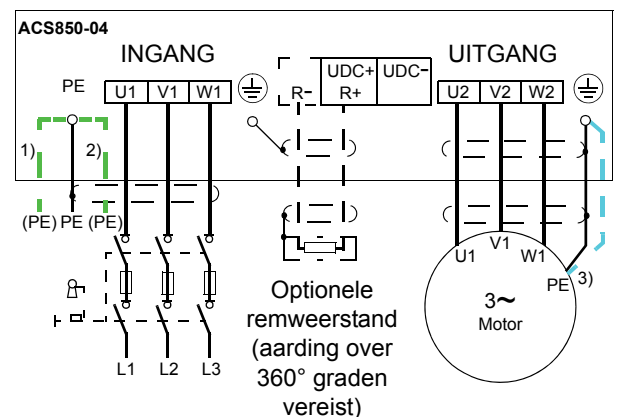

Opmerkingen:

- Gebruik geen onafgeschermd of asymmetrische motorkabel. Het wordt ook aanbevolen om een afgeschermd kabel te gebruiken als voedingskabel.
- Als afgeschermd voedingskabel gebruikt wordt, en de geleidbaarheid van de afscherming kleiner is dan 50% van de geleidbaarheid van een fasegeleider, gebruik dan een kabel met een aardgeleider (1) of een aparte PE-kabel (2).
- Gebruik voor de motorkabels een aparte aardkabel (3) als de geleidbaarheid van de kabelafscherming kleiner is dan 50% van de geleidbaarheid van een fasegeleider en de kabel geen symmetrische aardgeleiders heeft.

Als de motor naast de geleidende afscherming een symmetrische aardgeleider bevat, sluit de aardgeleider dan aan op de aardklemmen aan het omvormeruiteinde en aan het motoruit einde.

Aansluitprocedure

Voorbeelden van bekabeling zijn hieronder te zien. Aandraaimomenten zijn te vinden op pag. 47 en op de betreffende punten in de tekst.

- Verwijder de plastic afdekking van de hoofdklemmen. Til met een schroevendraaier vanuit de hoek op.
- Sluit de getwiste afschermingen van de vermogenskabels en aparte aardgeleiders aan op de aardklemmen van de omvormer-module.
- Sluit de fasegeleiders van de voedingskabel aan op klemmen U1, V1 en W1 en de fasegeleiders van de motorkabel op de klemmen U2, V2 en W2. De aanbevolen striplengte is 16 mm (0,63") voor frame E0 en 28 mm (1,1") voor frame E.
- Zet de kabels buiten de omvormermodule mechanisch vast.
- Snij gaten in de afdekking van helder plastic voor de geïnstalleerde kabels om de vermogenskabels te kunnen leiden. Druk de afdekking op de klemmen.
- Sluit de andere uiteinden van de vermogenskabels aan. Besteed om veiligheidsredenen extra aandacht aan het aansluiten van de aardgeleiders.

Voorbeelden van bekabeling

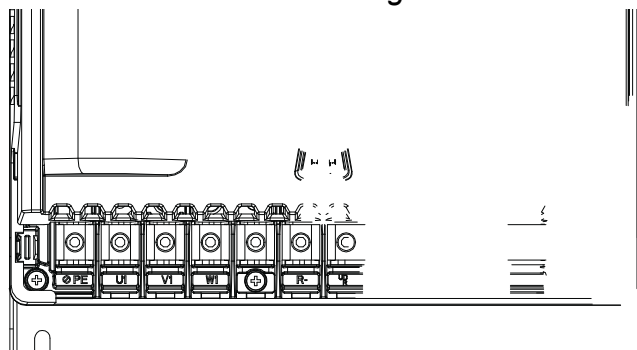

Frame-afmeting E: Installatie via schroefklemmen
(kabels van 95 tot 240 mm² [AWG3/0 tot 500MCM])

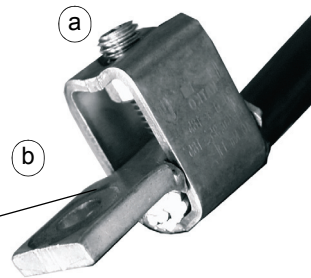
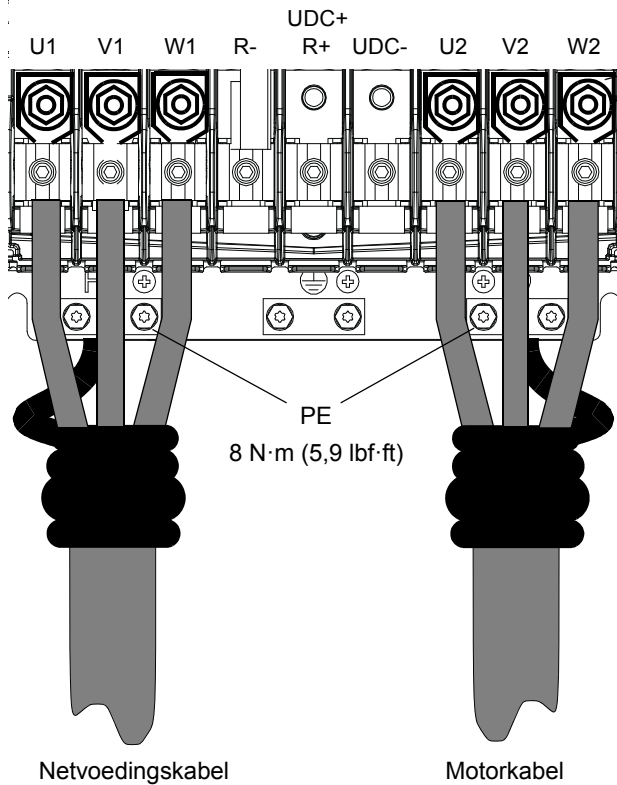

- Sluit de kabel aan op de klem. Draai de inbusschroef aan tot 20...40 N·m (15...30 lbf·ft).
- Sluit de klem aan op de omvormer. Draai aan tot 30...44 N·m (22...32 lbf·ft).



WAARSCHUWING! Als de afmeting van de draad minder is dan 95 mm² (3/0 AWG), dan moet een krimpschoen gebruikt worden. Een kabel met draadafmeting van minder dan 95 mm² (3/0 AWG) die op deze klem is aangesloten, zal losraken en kan de omvormer beschadigen.

Geleider-afmetingen van vermogensklemmen

Omvormertype ACS850-04...	Aderdiameter
-103A-5, -144A-5	6 ... 70 mm ²
-166A-5...-290A-5	95 ... 240 mm ²

Aanhaalmomenten

Omvormertype ACS850-04...	Vermogensklemmen	PE
	N·m (lbf·ft)	N·m (lbf·ft)
-103A-5, -144A-5	15 (11)	15 (11)
-166A-5...-290A-5	Installatie via kabelschoen 30...44 (22...32)	8 (5,9)
	Inbusschroef 20...40 (15...30)	8 (5,9)
	Schroefklem installatie 30...44 (22...32)	

Installeren besturingskabels

Standaard I/O aansluitschema

Opmerkingen:

[Standaard instelling bij ACS850 Standaard Besturingsprogramma (fabrieksmacro).

*Totale maximum stroom: 200 mA

De getoonde bedrading is alleen ter illustratie.

Voor de jumper-instellingen: zie tekst.

Geleiderafmetingen en aandraaimomenten:

XPOW, XRO1, XRO2, XRO3, XD24:
0,5 ... 2,5 mm² (24...12 AWG). Moment: 0,5 N·m (5 lbf·in)

XDI, XDIO, XAI, XAO, XD2D, XSTO:
0,5 ... 1,5 mm² (28...14 AWG). Moment: 0,3 N·m (3 lbf·in)

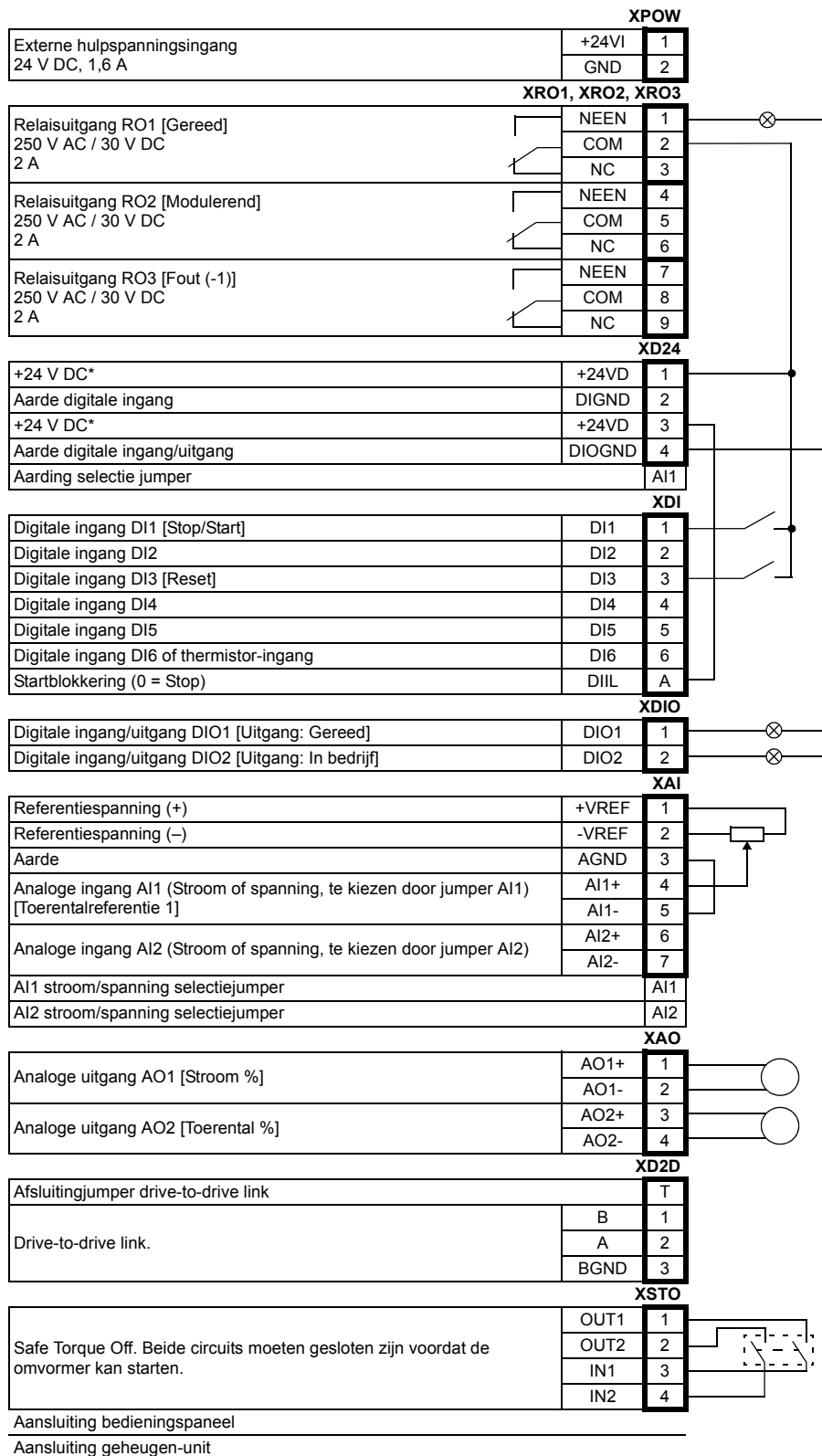
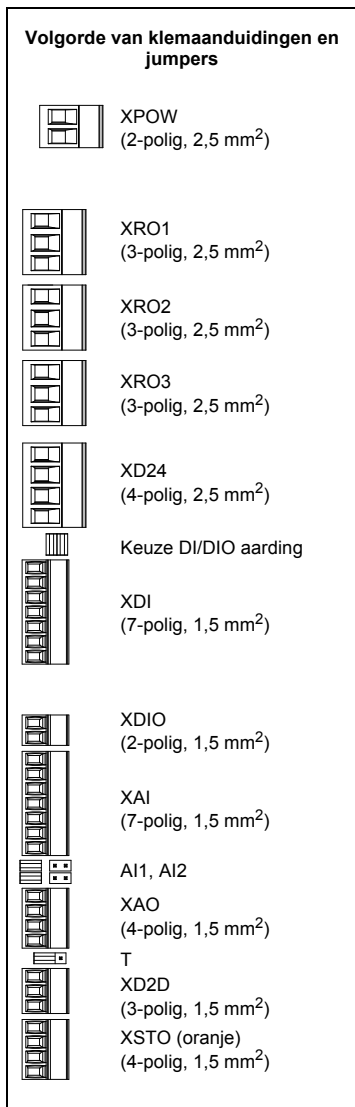

Jumpers op de besturingsunit: DI/DIO aardingselector (bevindt zich tussen XD24 en XDI) – Bepaalt of de DIGND (aarde voor digitale ingangen DI1...DI5) zweeft, of dat deze aangesloten wordt op DIOGND (aarde voor DI6, DIO1 en DIO2). Als DIGND zweeft, dient de gemeenschappelijke aarde van DI1...DI5 aangesloten te worden op XD24:2. De gemeenschappelijke aarde kan of GND zijn, of V_{CC} aangezien DI1...DI5 van het type NPN/PNP zijn.

DIGND zweeft

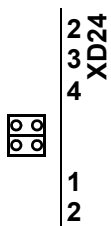

DIGND verbonden met DIOGND

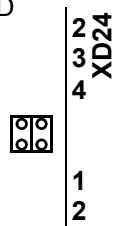

AI1 – Bepaalt of Analoge ingang AI1 wordt gebruikt als een stroom- of spanningsingang.

Stroom

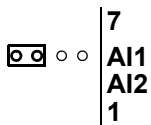

Spanning

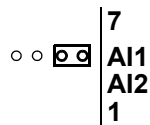

AI2 – Bepaalt of Analoge ingang AI2 wordt gebruikt als een stroom- of spanningsingang.

Stroom

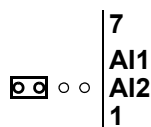

Spanning

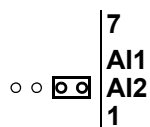

T – Afsluiting drive-to-drive link. Moet in de AAN-positie staan wanneer de omvormer de laatste unit van de verbinding is.

Afsluiting AAN



Afsluiting UIT

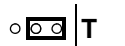

Ga verder met het opstarten van de omvormer volgens de instructies in de betreffende *Beknopte Opstartgids*.

Monteren van de klemplaat

De klemplaat voor besturingskabels kan bevestigd worden aan de bovenkant of de onderkant van de JCU besturingsunit.

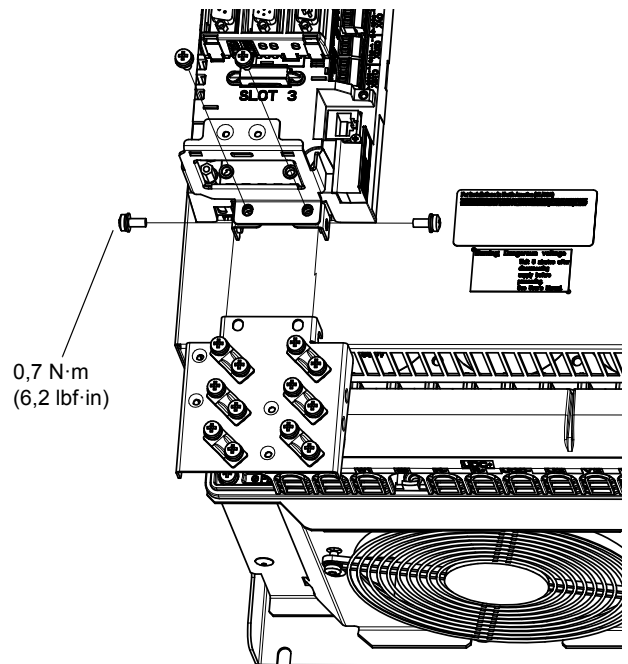

Leiden van de besturingskabels

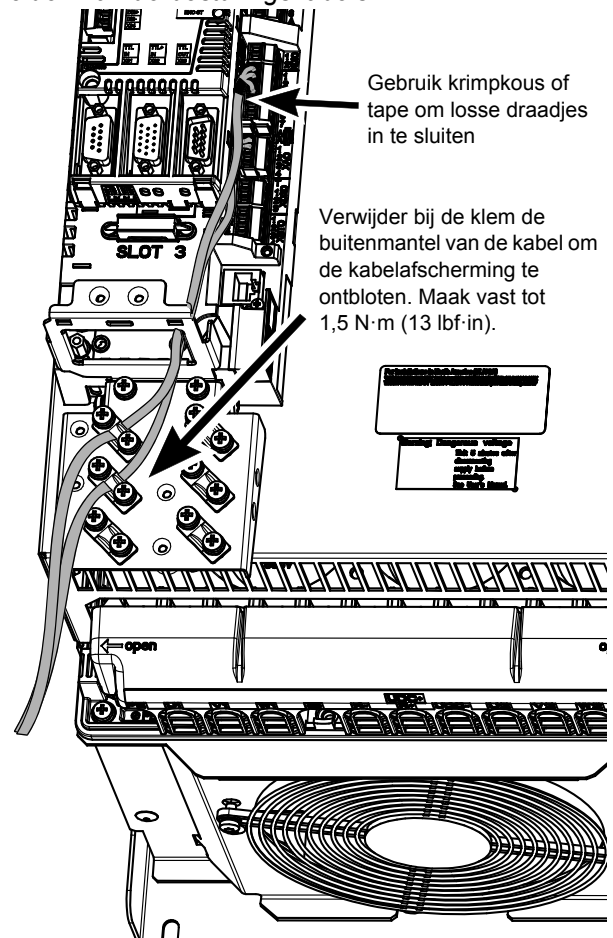

Technische gegevens

UL checklist

- De ACS850-04 is een IP20 (UL open type) omvormer voor gebruik in een verwarmde, gecontroleerde binnenomgeving. De omvormer moet in schone omgevingslucht worden geïnstalleerd conform de behuizingsclassificatie. De koellucht moet schoon, vrij van corrosieve materialen en van elektrisch geleidend stof zijn. Zie de *Hardware handleiding* voor verdere specificaties.
- De maximum omgevingsluchttemperatuur is 40 °C (104 °F) bij nominale stroom. De stroom dient gereduceerd te worden voor bedrijf bij 40 tot 55 °C (104 tot 131 °F).
- De omvormer is geschikt voor gebruik in een voedingscircuit dat niet meer kan leveren dan 100.000 rms symmetrische ampère, 500 V maximum.
- De kabels binnen het motorcircuit moeten bestand zijn tegen tenminste 75 °C (167 °F) in UL-goedgekeurde installaties.
- De ingangskabel moet beveiligd zijn met zekeringen of automaten. Geschikte IEC (klasse gG) en UL (klasse T) zekeringen zijn terug te vinden in de sectie *Technische gegevens* van de *Hardware handleiding*. Neem voor geschikte automaten contact op met uw plaatselijke ABB-vertegenwoordiger.
- Voor installatie in de Verenigde Staten moet worden voorzien in stroomkringbeveiliging volgens de National Electrical Code (NEC) en eventueel van toepassing zijnde plaatselijke codes. Gebruik de UL-geclassificeerde zekeringen om aan deze eis te voldoen.
- Voor installatie in Canada, moet worden voorzien in stroomkringbeveiliging volgens de Canadian Electrical Code en eventueel van toepassing zijnde provinciale codes. Gebruik de UL-geclassificeerde zekeringen om aan deze eis te voldoen.
- De omvormer voorziet in overbelastingsbeveiliging volgens de National Electrical Code (NEC). Zie de betreffende *Firmware handleiding* voor de instellingen van de overbelastingsbeveiliging.

Guia de instalação rápida – ACS850-04

Sobre este guia

Este guia contém informações básicas sobre a instalação mecânica e elétrica do módulo de acionamento ACS850-04 (55 a 200 kW). Para obter a documentação completa, consulte o *Manual de Hardware dos Módulos de Acionamento ACS850-04 (55 a 200 kW, 60 a 200 hp)* (código: 3AUA0000045487 [Inglês]).

Instruções de Segurança



ADVERTÊNCIA! Todo o trabalho de instalação e manutenção elétrica no acionamento deve ser realizado apenas por eletricitistas qualificados.

Nunca trabalhe no acionamento, no chopper de frenagem, no cabo do motor ou no motor quando a alimentação de energia estiver sendo aplicada no acionamento. Sempre se certifique, por meio de medição, de que não haja tensão.

Um motor ímã permanente em rotação pode gerar tensão perigosa. Bloqueie o eixo do motor mecanicamente antes de conectar um motor ímã permanente ao acionamento e antes de realizar qualquer trabalho em um sistema de acionamento conectado a um motor ímã permanente.

Instalação mecânica



ADVERTÊNCIA! Se for necessário conectar o acionamento a um sistema de energia de TI (p. ex., sistema de energia não aterrado ou com aterramento de alta resistência [acima de 30 ohms]), a filtragem de EMC interna do acionamento deve ser desconectada. Isso deve ser feito antes de o acionamento ser instalado mecanicamente. Consulte o *Manual de Hardware* para obter instruções detalhadas.

Fixe o módulo de acionamento na parede, com quatro parafusos.

Instalação dos cabos de alimentação

Diagrama de conexão

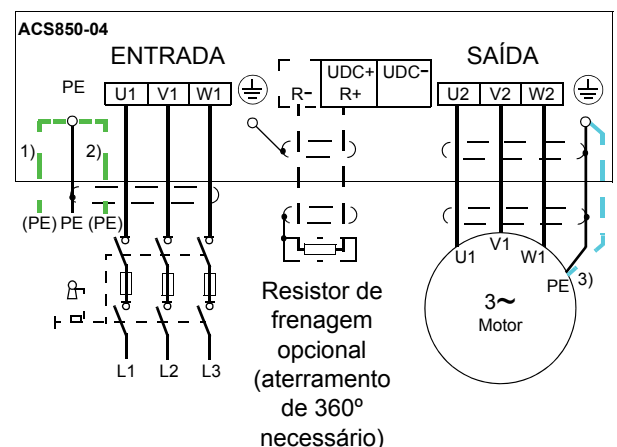

Observações:

- Não use um cabo de motor de construção assimétrica ou não blindado. É recomendado usar um cabo blindado também como cabo de alimentação (entrada).
- Se for usado um cabo de alimentação (entrada) blindado e a condutividade da blindagem for menor de 50% da condutividade de um condutor de fase, use um cabo com um condutor terra (1) ou um cabo PE separado (2).
- Para o cabeamento do motor, use um cabo terra (3) separado se a condutividade da blindagem do cabo for menor do que 50% da condutividade de um condutor de fase e se o cabo não possuir condutores terra simétricos.

Se houver um condutor terra simetricamente construído no cabo do motor além da blindagem condutora, conecte-o nos conectores de terra em ambas as extremidades do acionamento e do motor.

Procedimento de conexão

Exemplos de cabeamento são apresentados abaixo. Os torques de aperto são apresentados na página 53 e nos momentos apropriados no texto.

- Remova a capa plástica cobrindo os terminais principais. Levante com uma chave de fenda, a partir do canto.
- Conecte as blindagens torcidas dos cabos de força e separe os condutores de aterramento dos terminais de aterramento do módulo de acionamento.
- Conecte os condutores de fase do cabo de alimentação nos terminais U1, V1 e W1 e conecte os condutores de fase do cabo do motor nos terminais U2, V2 e W2. O comprimento de desencapamento recomendado é de 16 mm (0,63 polegada) para o tamanho da carcaça E0 e 28 mm (1,1 polegada) para o tamanho da carcaça E.
- Fixe os cabos mecanicamente na parte externa do módulo de acionamento.
- Faça furos na capa plástica transparente para os cabos instalados, para acomodar os cabos de força. Pressione a capa nos terminais.
- Conecte as outras extremidades dos cabos de força. Para garantir a segurança, preste atenção especial à conexão dos condutores de aterramento.

Tamanho da carcaça E: Instalação dos ganchos de cabo (cabos de 16 a 70 mm² [AWG6 a AWG2/0])

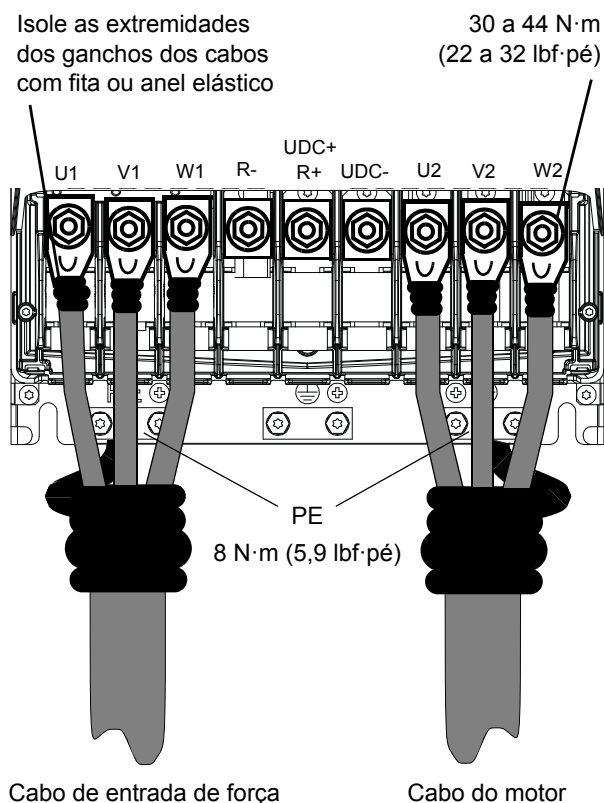

Exemplos de cabeamento

Tamanho da carcaça E0: Instalação dos parafusos do terminal

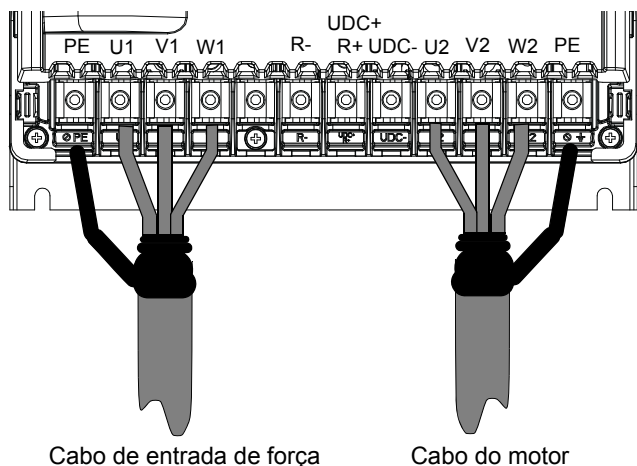

Tamanho da carcaça E: Instalação dos parafusos do terminal (cabos de 95 a 240 mm² [AWG3/0 a 500MCM])

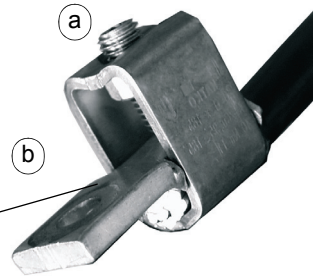
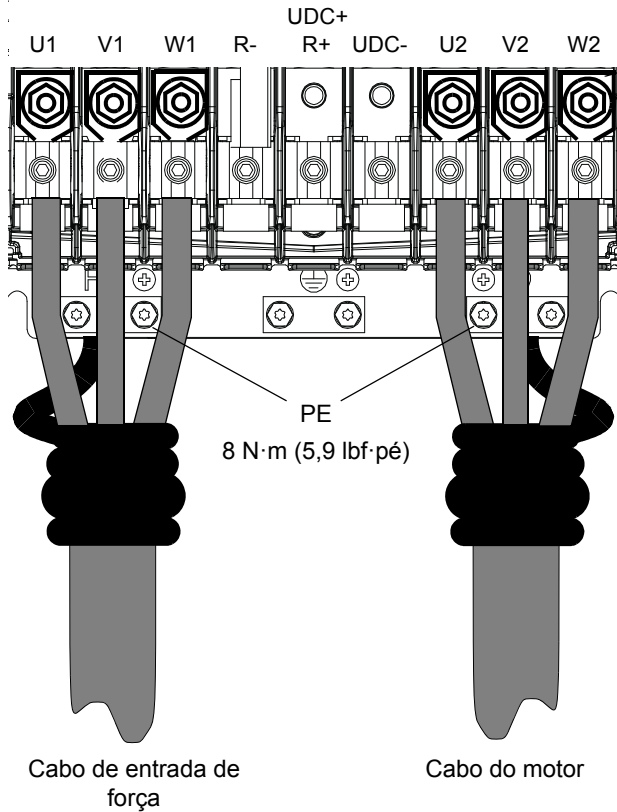

- Conecte o cabo ao terminal. Aperte o parafuso Allen com 20 a 40 N·m (15 a 30 lbf-pé).
- Conecte o terminal no acionamento. Aperte com 30 a 44 N·m (22 a 32 lbf-pé).



ADVERTÊNCIA! Se o tamanho do fio for menor do que 95 mm² (3/0 AWG), um terminal crimpado deve ser usado. Um cabo cujo fio seja menor do que 95 mm² (3/0 AWG) conectado a esse terminal ficará frouxo e poderá danificar a unidade.

Tamanhos de cabo aceitos pelos terminais de alimentação

Tipo de acionamento ACS850-04...	Tamanho do cabo
-103A-5, -144A-5	6 a 70 mm ²
-166A-5 a -290A-5	95 a 240 mm ²

Torques de aperto

Tipo de acionamento ACS850-04...	Terminais de alimentação	PE
	N·m (lbf-pé)	N·m (lbf-pé)
-103A-5, -144A-5	15 (11)	15 (11)
-166A-5 a -290A-5	Instalação dos ganchos de cabo 30...44 (22...32)	8 (5,9)
	Parafuso Allen 20...40 (15...30) Instalação dos parafusos do terminal 30...44 (22...32)	8 (5,9)

Instalação dos cabos de controle

Diagrama padrão da conexão de E/S

Observações:

[Configuração padrão com o programa de controle padrão do ACS850 (macro de fábrica).

*Corrente máxima total: 200 mA

A fiação exibida é apenas para fins demonstrativos.

Para obter as configurações dos jumpers, consulte o texto.

Dimensões do fio e torques de aperto:

XPOW, XRO1, XRO2, XRO3, XD24: 0,5 a 2,5 mm² (24 a 12 AWG). Torque: 0,5 N·m (5 lbf·pol)

XDI, XDIO, XAI, XAO, XD2D, XSTO: 0,5 a 1,5 mm² (28 a 14 AWG). Torque: 0,3 N·m (3 lbf·pol)

Ordem da nomenclatura dos terminais e jumpers

- XPOW (2 polos, 2,5 mm²)
- XRO1 (3 polos, 2,5 mm²)
- XRO2 (3 polos, 2,5 mm²)
- XRO3 (3 polos, 2,5 mm²)
- XD24 (4 polos, 2,5 mm²)
- Seleção de aterramento DI/DIO
- XDI (7 polos, 1,5 mm²)
- XDIO (2 polos, 1,5 mm²)
- XAI (7 polos, 1,5 mm²)
- A11, A12
- XAO (4 polos, 1,5 mm²)
- T
- XD2D (3 polos, 1,5 mm²)
- XSTO (laranja) (4 polos, 1,5 mm²)

XPOW		
Entrada de alimentação externa 24 Vcc, 1,6 A	+24VI	1
	GND	2
XRO1, XRO2, XRO3		
Saída de relé RO1 [Pronta] 250 Vca / 30 Vcc 2 A	NO	1
	COM	2
	NC	3
Saída de relé RO2 [Modulando] 250 Vca / 30 Vcc 2 A	NO	4
	COM	5
	NC	6
Saída de relé RO3 [Falha (-1)] 250 Vca / 30 Vcc 2 A	NO	7
	COM	8
	NC	9
XD24		
+24 VCC*	+24VD	1
Aterramento de entrada digital	DIGND	2
+24 VCC*	+24VD	3
Aterramento de entrada/saída digital	DIOGND	4
Jumper de seleção de terra		A11
XDI		
Entrada digital DI1 [Parada/Partida]	DI1	1
Entrada digital DI2	DI2	2
Entrada digital DI3 [Restaurar]	DI3	3
Entrada digital DI4	DI4	4
Entrada digital DI5	DI5	5
Entrada digital DI6 ou entrada do termistor	DI6	6
Trava de partida (0 = Parada)	DIIL	A
XDIO		
Entrada/Saída digital DIO1 [Saída: Pronta]	DIO1	1
Entrada/Saída digital DIO2 [Saída: Funcionamento]	DIO2	2
XAI		
Tensão de referência (+)	+VREF	1
Tensão de referência (-)	-VREF	2
Terra	AGND	3
Entrada analógica AI1 (corrente ou tensão, selecionável pelo jumper AI1) [Referência de velocidade 1]	AI1+	4
	AI1-	5
Entrada analógica AI2 (corrente ou tensão, selecionável pelo jumper AI2)	AI2+	6
	AI2-	7
Jumper de seleção de corrente/tensão AI1		A11
Jumper de seleção de corrente/tensão AI2		A12
XAO		
Saída analógica AO1 [corrente %]	AO1+	1
	AO1-	2
Saída analógica AO2 [velocidade %]	AO2+	3
	AO2-	4
XD2D		
Terminação da ligação de acionamento a acionamento	T	
Ligação acionamento a acionamento.	B	1
	A	2
	BGND	3
XSTO		
Torque Seguro Desligado. Ambos os circuitos devem ser fechados para que o acionamento seja iniciado.	OUT1	1
	OUT2	2
	IN1	3
	IN2	4
Conexão do painel de controle		
Conexão do inversor de memória		

Jumpers na unidade de controle: Seletor de aterramento DI/DIO (localizado entre XD24 e XDI) – Determina se DIGND (aterramento para as entradas digitais DI1 a DI5) flutua ou se está conectado a DIOGND (aterramento para DI6, DIO1 e DIO2). Caso DIGND flutue, a opção comum das entradas digitais DI1 a DI5 deve ser conectada a XD24:2. A opção comum pode ser GND ou V_{CC}, uma vez que DI1 a DI5 são do tipo NPN/PNP.

DIGND flutua DIGND vinculado a DIOGND

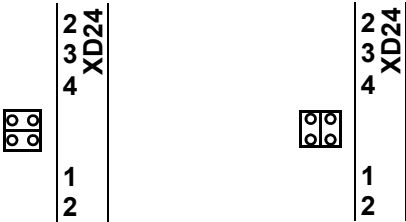

AI1 – Determina se a entrada analógica AI1 é usada como uma entrada de corrente ou tensão.

Corrente Tensão



AI2 – Determina se a entrada analógica AI2 é usada como uma entrada de corrente ou tensão.

Corrente Tensão



T – Terminação de ligação acionamento a acionamento. Deve ser colocado na posição ON (LIGADO) quando o acionamento for a última unidade na ligação.

Terminação ON (ligada) Terminação OFF (desligada)

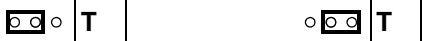

Continue com a inicialização do acionamento de acordo com as instruções no *Guia de Início Rápido* apropriado.

Montagem da chapa de aperto

A chapa de aperto pode ser presa na parte superior ou inferior da Placa de Controle JCU.

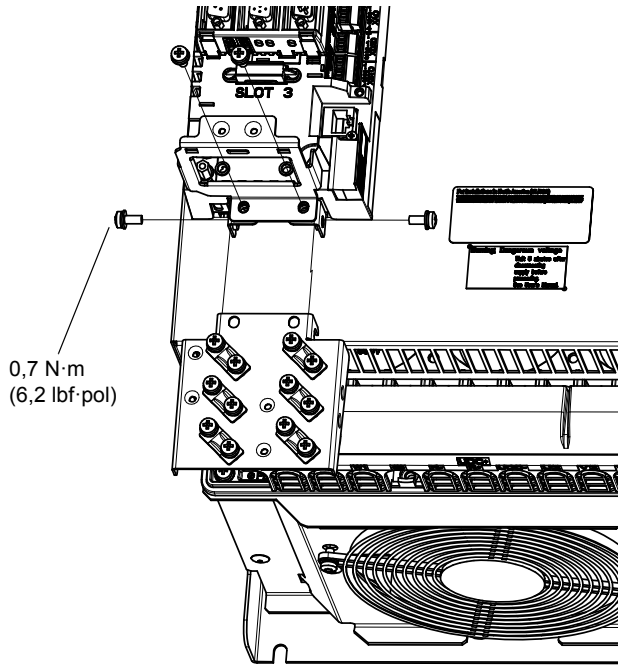

Roteamento dos cabos de controle.

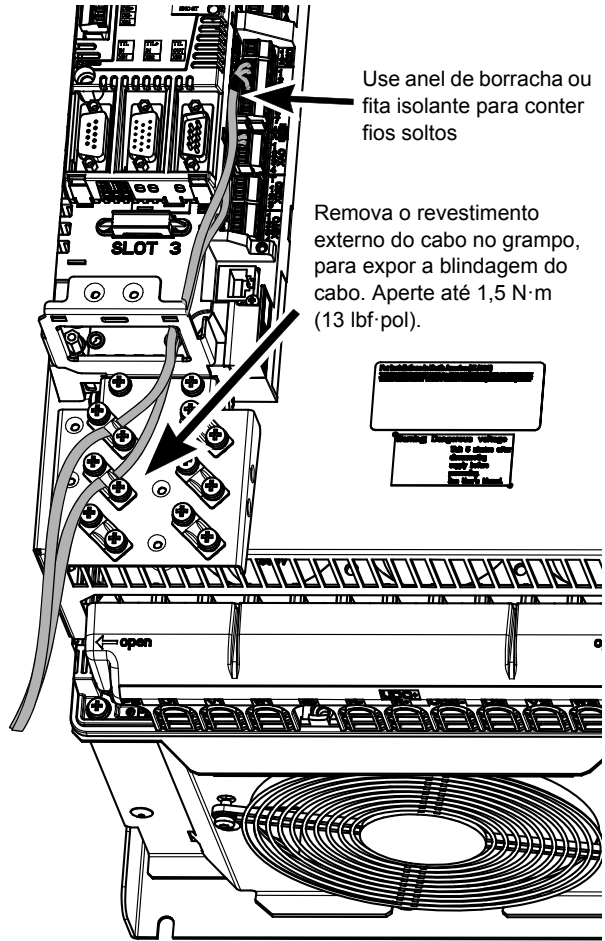

Dados técnicos

Lista de verificação de UL

- O ACS850-04 é um acionamento IP20 (UL tipo aberto) que deve ser utilizado em ambiente aquecido, interno e controlado. O acionamento deve estar instalado em ar puro, de acordo com a classificação do alojamento. O ar de resfriamento deve ser limpo, livre de material corrosivo e poeira eletricamente condutora. Consulte o *Manual de Hardware* para obter especificações detalhadas.
- A temperatura ambiente máxima do ar é de 40 °C (104 °F) na corrente nominal. A corrente cai para 40 a 55 °C (104 a 131 °F).
- O acionamento é adequado para uso em um circuito capaz de fornecer no máximo 100.000 rms ampères simétricos, máximo de 500 V.
- Os cabos localizados no interior do circuito do motor devem ser classificados para pelo menos 75 °C (167 °F) em instalações em conformidade com UL.
- O cabo de entrada deve ser protegido com fusíveis ou disjuntores. Os fusíveis IEC (classe gG) e UL (classe T) adequados estão relacionados na seção *Dados técnicos* do *Manual de Hardware*. Para saber quais são os disjuntores adequados, entre em contato com seu representante ABB local.
- Para instalação nos Estados Unidos, deve ser providenciada proteção de circuito derivado, de acordo com o NEC (National Electrical Code - Código Elétrico Nacional) e quaisquer códigos municipais aplicáveis. Para cumprir esse requisito, use fusíveis com classificação UL.
- Para instalação no Canadá, deve ser providenciada proteção de circuito derivado, de acordo com o Código Elétrico Canadense (Canadian Electrical Code) e quaisquer códigos provinciais aplicáveis. Para cumprir esse requisito, use fusíveis com classificação UL.
- O acionamento fornece proteção contra sobrecarga de acordo com o Código Elétrico Nacional (NEC), dos EUA. Consulte o *Manual de Firmware* apropriado para saber quais são as configurações de proteção contra sobrecarga.

Краткое руководство по монтажу – ACS850-04

Об этом руководстве

В этом руководстве содержится самая общая информация о механическом и электрическом монтаже привода ACS850-04 (55 – 200 кВт). Полное описание приведено в документе *Руководство по монтажу и эксплуатации модулей приводов ACS850-04 (55 – 200 кВт, 60 – 200 л.с.)* (код: ЗАУА0000045487 [англ. версия]).

Инструкция по технике безопасности



ПРЕДУПРЕЖДЕНИЕ! Все работы по электрическому монтажу и техническому обслуживанию приводов должны выполняться только квалифицированными электриками.

Запрещается выполнять работы на приводе, цепи тормозного прерывателя, кабелях и двигателе при включенном входном питании привода. Перед тем как приступить к работе, следует измерить напряжение, чтобы убедиться в его отсутствии.

Вращающийся двигатель с постоянными магнитами генерирует опасное напряжение. Перед подключением двигателя с постоянными магнитами к приводу или перед выполнением любых работ на подключенной к двигателю с постоянными магнитами системе привода необходимо физически заблокировать вал двигателя.

Механический монтаж



ПРЕДУПРЕЖДЕНИЕ! Если привод подключен к системе питания ИТ (т.е. к незаземленной или заземленной через большое сопротивление [более 30 Ом] системе питания), внутренний фильтр ЭМС привода должен быть отключен. Это необходимо сделать до механического монтажа привода. Подробное описание см. в *Руководстве по монтажу и эксплуатации*.

Закрепите модуль привода на стене с помощью четырех винтов.

Монтаж силовых кабелей

Схема подключения

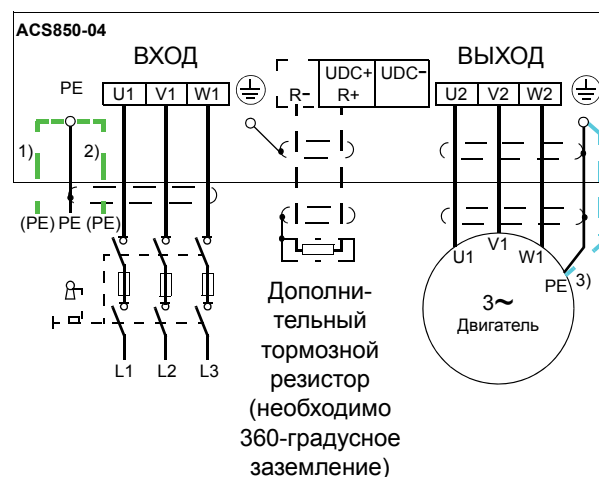

Примечания.

– Не применяйте неэкранированный или асимметричный кабель для подключения двигателя. Рекомендуется использовать экранированный кабель также в качестве кабеля питания (входного).

– В случае использования экранированного кабеля питания (входного) при проводимости экрана менее 50 % проводимости фазного провода, используйте кабель с заземляющим проводом (1) или отдельным кабелем защитного заземления PE (2).

- Если проводимость экрана кабеля составляет менее 50 % проводимости фазного провода и кабель не имеет симметричных проводов заземления, для подключения двигателя используйте отдельный кабель заземления (3).

При подключении двигателя кабелем с проводящим экраном и симметричной структурой проводника заземления подсоедините концы проводника заземления к проводникам заземления со стороны привода и двигателя.

Методика подключения

Ниже представлены примеры подключения кабелей. Моменты затяжки представлены на стр. 59 и в соответствующих разделах документа.

- Удалите пластмассовую крышку с силовых клемм. Поднимите отверткой с угла.
- Присоедините скрученные экраны силовых кабелей и отдельные заземляющие проводники к клеммам заземления модуля привода.
- Подключите фазные проводники кабеля питания к клеммам U1, V1 и W1, а фазные проводники кабеля двигателя – к клеммам U2, V2 и W2. Рекомендуемая длина зачистки проводников составляет 16 мм для типоразмера E0 и 28 мм – для типоразмера E.
- Обеспечьте механическое крепление кабелей снаружи модуля привода.
- Вырежьте отверстия под монтируемые силовые кабели в прозрачной пластмассовой крышке. Наденьте защитную крышку на клеммы.
- Подключите другие концы силовых кабелей. Чтобы обеспечить безопасность, будьте внимательны при подключении проводников заземления.

Примеры подключения кабелей

Типоразмер E0: подключение к винтовым клеммам

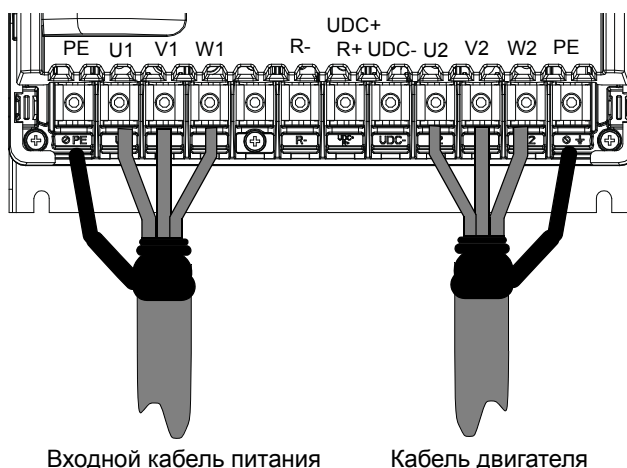

Входной кабель питания

Кабель двигателя

Типоразмер E: Подключение с помощью кабельных наконечников (кабели сечением 16 – 70 мм²)

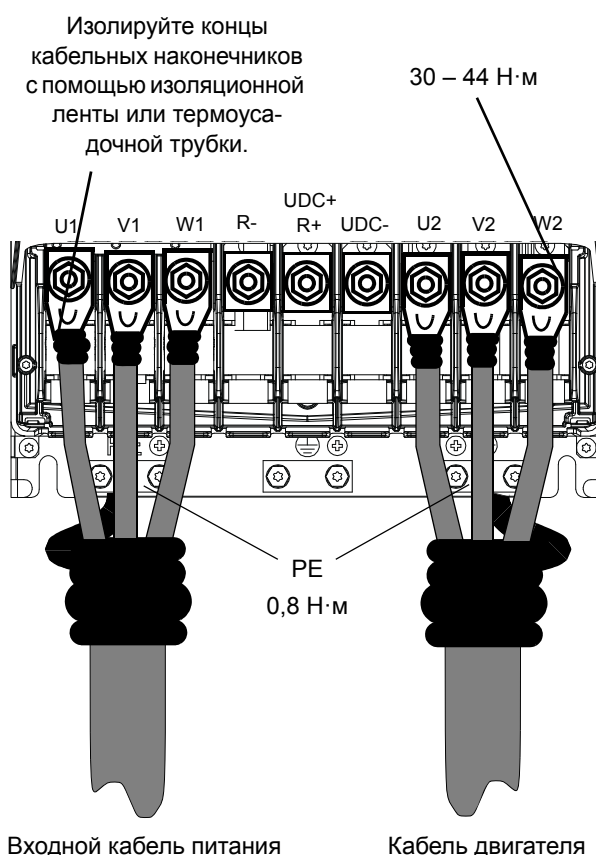

Входной кабель питания

Кабель двигателя

Типоразмер E: Монтаж с кабельными зажимами (кабели сечением 95 – 240 мм²)

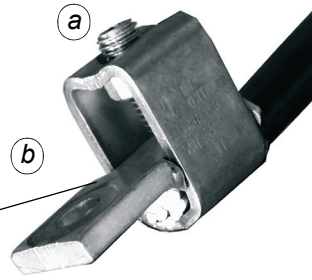
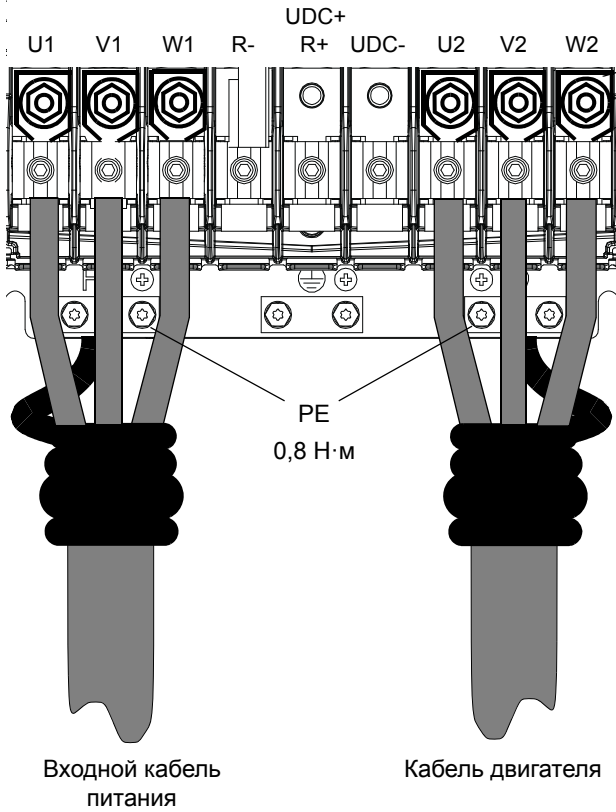

- a. Подсоедините кабель к зажиму. Затяните винт с внутренним шестигранником с моментом 20 – 40 Н·м.
- b. Подсоедините зажим к приводу. Затяните с моментом 30 – 44 Н·м.



ПРЕДУПРЕЖДЕНИЕ! Если проводник имеет сечение менее 95 мм², необходимо использовать обжимной наконечник. В случае присоединения проводников сечением менее 95 мм² непосредственно к клеммам, соединение ослабляется, что может привести к повреждению привода.

Сечения проводов, которые могут быть подключены к силовым клеммам

Тип привода ACS850-04...	Сечение провода
-103A-5, -144A-5	6 – 70 мм ²
-166A-5 – -290A-5	95 – 240 мм ²

Моменты затяжки

Тип привода ACS850-04...	Силовые клеммы	PE
	Н·м (фунт-футы)	Н·м (фунт-футы)
-103A-5, -144A-5	15 (11)	15 (11)
-166A-5 – -290A-5	Подключение с помощью кабельных наконечников 30 – 44 (22 – 32)	8 (5,9)
	Винт с внутренним шестигранником 20 – 40 (15 – 30) Подключение к винтовым клеммам 30 – 44 (22 – 32)	8 (5,9)

Монтаж кабелей управления

Стандартная схема подключения входов/выходов

Примечания.

[Установка по умолчанию при использовании стандартной программы управления ACS850 (заводской макрос).

*Максимальный суммарный ток: 200 мА

Схема показана только для примера.

Относительно расположения перемычек см. текст.

Сечения проводов и моменты затяжки:

XPOW, XRO1, XRO2, XRO3, XD24:

0,5 – 2,5 мм². Момент затяжки: 0,5 Н·м

XDI, XDIO, XAI, XAO, XD2D, XSTO:

0,5 – 1,5 мм². Момент затяжки: 0,3 Н·м

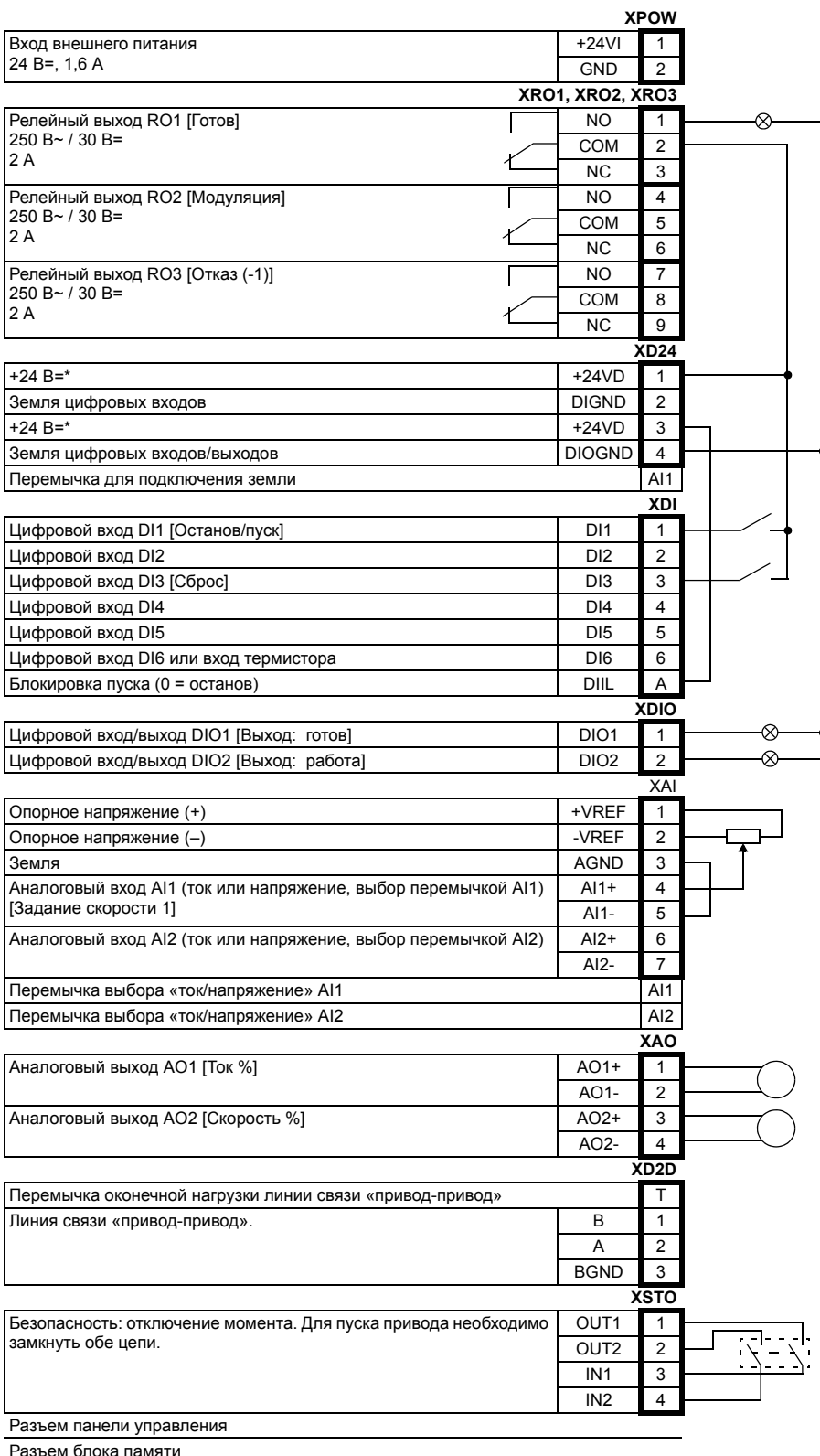

Переключатель на блоке управления

Переключатель выбора заземления DI/DIO (установленный между XD24 и XD1) – определяет, будет ли точка DIGND (земля для цифровых входов DI1 – DI5) плавающей или она будет подключена к DIOGND (земля для DI6, DIO1 и DIO2). Если точка DIGND является плавающей, общая точка цифровых входов DI1 – DI5 должна быть подключена к XD24:2. Общей точкой может быть либо GND, либо V_{CC} , поскольку DI1 – DI5 – входы типа NPN/PNP.

Точка DIGND
плавающая

Точка DIGND соединена
с DIOGND

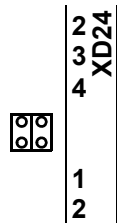
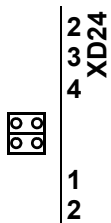

AI1 – определяет, как используется аналоговый вход AI1 – в качестве входа тока или напряжения.

Ток

Напряжение

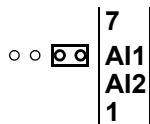
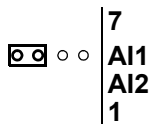

AI2 – определяет, как используется аналоговый вход AI2 – в качестве входа тока или напряжения.

Ток

Напряжение

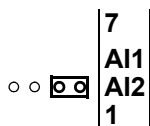
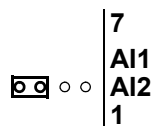

T – оконечная нагрузка линии связи «привод-привод». Переключатель должен быть установлен в положение ON (ВКЛ), если привод является последним блоком линии связи.

Оконечная нагрузка
включена

Оконечная нагрузка
выключена



Продолжите процедуру ввода привода в эксплуатацию в соответствии с указаниями *Краткого руководства по вводу в эксплуатацию*.

Монтажная пластина с кабельными зажимами

Монтажная пластина с кабельными зажимами может быть установлена в верхней или нижней части блока управления JCU.

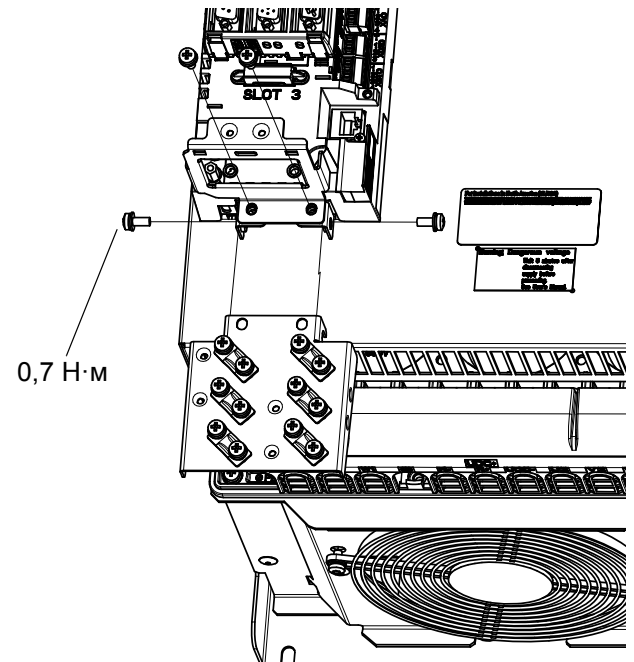

Прокладка кабелей управления

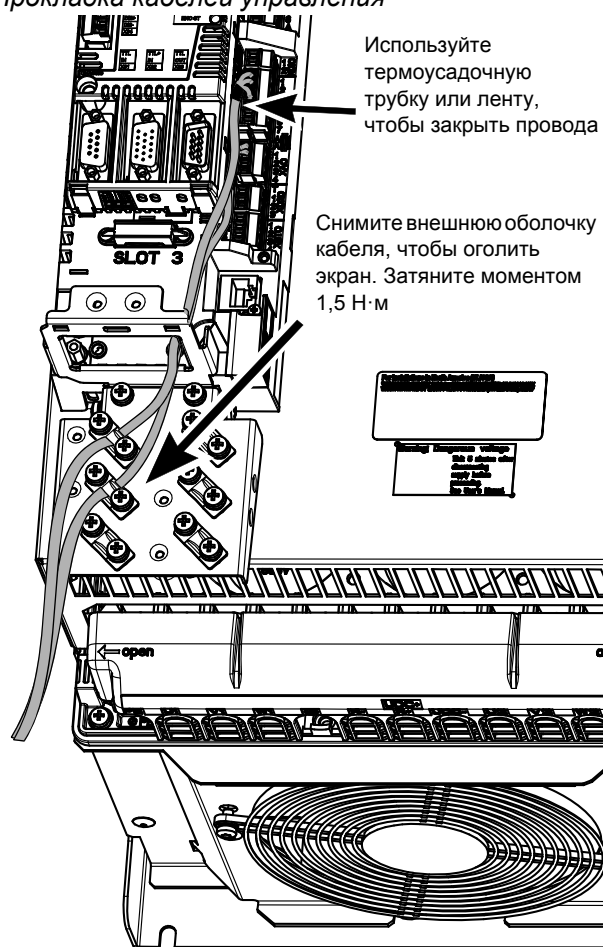

должен быть снижен при температурах от 40 до 55 °С.

- Привод предназначен для использования в сетях с максимальными среднеквадратичными значениями симметричного тока не более 100 000 А при напряжении не более 500 В.
- Кабели, служащие для подключения двигателя, должны выдерживать температуру не менее 75 °С в установках, соответствующих стандарту UL.
- Входной кабель должен быть защищен плавкими предохранителями или автоматическими выключателями. Соответствующие стандартам IEC (класс gG) и UL (класс T) плавкие предохранители перечислены в разделе *Технические характеристики Руководства по монтажу и эксплуатации*. Информацию о соответствующих требованиях автоматических выключателях можно получить в местном представительстве ABB.
- Для монтажа в США должна быть обеспечена защита цепей в соответствии с Национальным сводом законов и технических стандартов США по электротехнике (NEC) и всеми действующими местными нормами и правилами. Для выполнения этих требований используйте плавкие предохранители с сертификацией UL.
- Для монтажа в Канаде должна быть обеспечена защита цепей в соответствии с Канадским электротехническим кодексом и всеми действующими нормами и правилами провинций. Для выполнения этих требований используйте плавкие предохранители с сертификацией UL.
- Привод обеспечивает защиту от перегрузки в соответствии с Национальным сводом законов и технических стандартов США по электротехнике (NEC). Информацию о защите от перегрузки см. в соответствующем документе – *Руководство по микропрограммному обеспечению*.

Технические характеристики

Контрольный перечень UL

- Привод ACS850-04 имеет класс защиты IP20 (открытого типа по стандарту UL) и предназначен для использования в отапливаемых закрытых помещениях с контролируемыми условиями. Привод должен быть установлен в помещении с чистым сухим воздухом в соответствии с классом защиты корпуса. Охлаждающий воздух должен быть чистым и не должен содержать агрессивных веществ, а также электропроводящей пыли. Подробное описание см. в *Руководстве по монтажу и эксплуатации*.
- Максимальная температура окружающего воздуха: 40 °С при номинальном токе. Ток

Snabbguide för installation – ACS850-04

Om denna guide

Denna guide innehåller den mest grundläggande informationen om mekanisk och elektrisk installation av frekvensomriktarmodul ACSM850-04 (55 till 200 kW). För komplett dokumentation se *ACSM850-04 Drive Modules (55 to 200 kW) Hardware Manual* (kod: 3AUA0000045487 [engelska]).

Säkerhetsanvisningar



VARNING! Allt elektriskt installations- och underhållsarbete på frekvensomriktaren måste utföras av behörig elektriker.

Arbeta aldrig med frekvensomriktaren, broms-chopperkretsen, motorkabeln eller motorn när systemet är spänningssatt. Kontrollera alltid genom mätning att ingen spänning finns.

En roterande permanentmagnetmotor kan generera farlig spänning. Lås motoraxeln mekaniskt före anslutning av en permanentmagnetmotor till frekvensomriktaren och före varje ingrepp i en frekvensomriktare som är ansluten till en permanentmagnetmotor.

Mekanisk installation



VARNING! Om frekvensomriktaren skall anslutas till ett IT-nät (dvs. ett ojordat eller högresistivt [över 30 ohm] jordat nät måste frekvensomriktarens interna EMC-filer kopplas bort. Detta skall utföras innan frekvensomriktaren installeras mekaniskt. Se *Hårdvaruhandledning* för detaljerade instruktioner.

Montera frekvensomriktarmodulen på väggen med fyra skruvar.

Installation av kraftkablar

Kretsschema

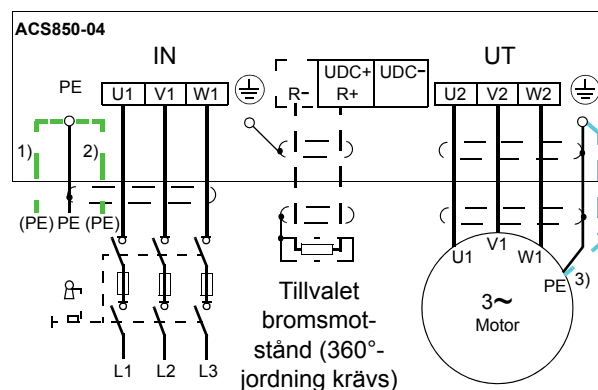

Noter:

- Använd inte oskärmad eller asymmetrisk motorkabel. Vi rekommenderar skärmad kabel även som nätkabel (matningskabel).
 - Om skärmade nätkablar (matningskablar) används, och konduktiviteten hos skärmen är mindre än 50 % av konduktiviteten hos en fasledare, använd en kabel med jordledare (1) eller en separat PE-kabel (2).
 - För motoranslutningen, använd en separat jordkabel (3) om konduktiviteten hos motorkabelskärmen understiger 50 % av den hos en fasledare och kabeln saknar symmetriska jordledare.
- Om det finns en symmetrisk jordningsledare i motorkabeln förutom den ledande skärmen, anslut den till jordanslutningsterminalerna i frekvensomriktar- och motorändarna.

Anslutningsprocedur

Exempel på kabelanslutning presenteras nedan. Åtdragningsmoment anges på sid 65 och i den löpande texten.

- Ta bort plastkåpan över matningsplintarna. Lyft i hörnet med en skruvmejsel.
- Anslut kraftkablarnas ooptvinnade skärmar och separata jordledare till frekvensomriktarens jordplintar.
- Anslut matningskabelns fasledare till plintarna U1, V1 och W1, och motorkabelns fasledare till plintarna U2, V2 och W2. Rekommenderad skalningslängd är 16 mm för byggstorlek E0 och 28 mm för byggstorlek E.
- Fixera kablarna mekaniskt utanför frekvensomriktarmodulen.
- Skär hål för de installerade kablarna i den genomskinliga plastkåpan, för att låta kraftkablarna passera. Tryck plastkåpan över plintarna.
- Anslut den andra änden av kraftkablarna. För att garantera säkerheten, var särskilt noga med anslutningen av jordledarna.

Kabelanslutningsexempel:

Byggstorlek E0: Skruvplintinstallation

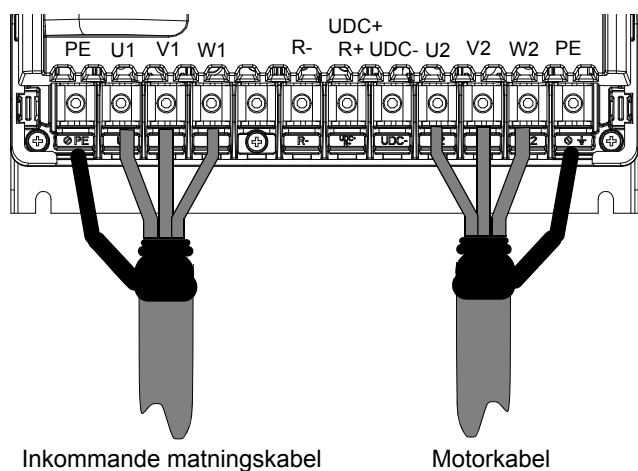

Byggstorlek E: Kabelskoinstallation, för kabeldimension 16 till 70 mm² (AWG6 till AWG2/0)

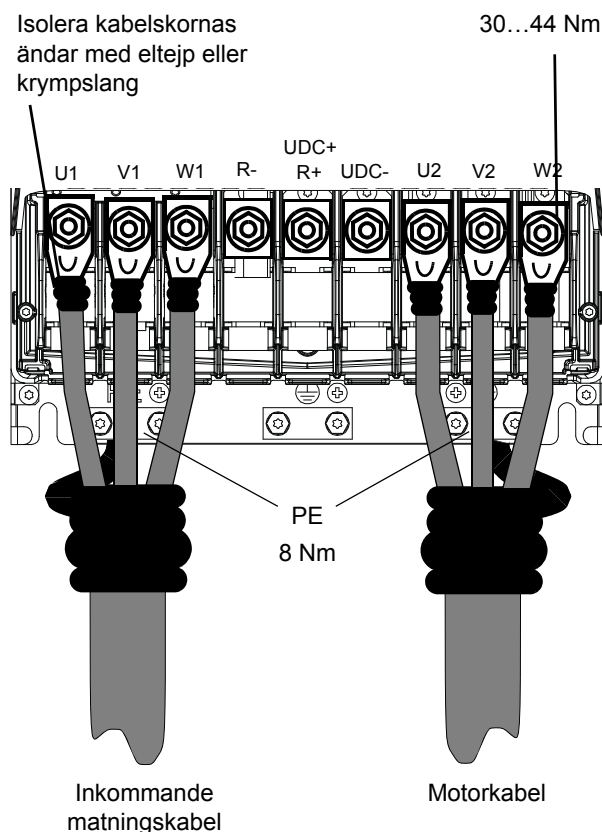

Byggstorlek E: Kabelanslutning med skruvplintar
(ledararea 95 till 240 mm² [AWG3/0 till 500MCM])

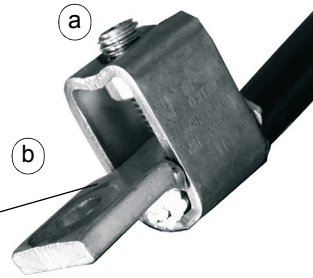
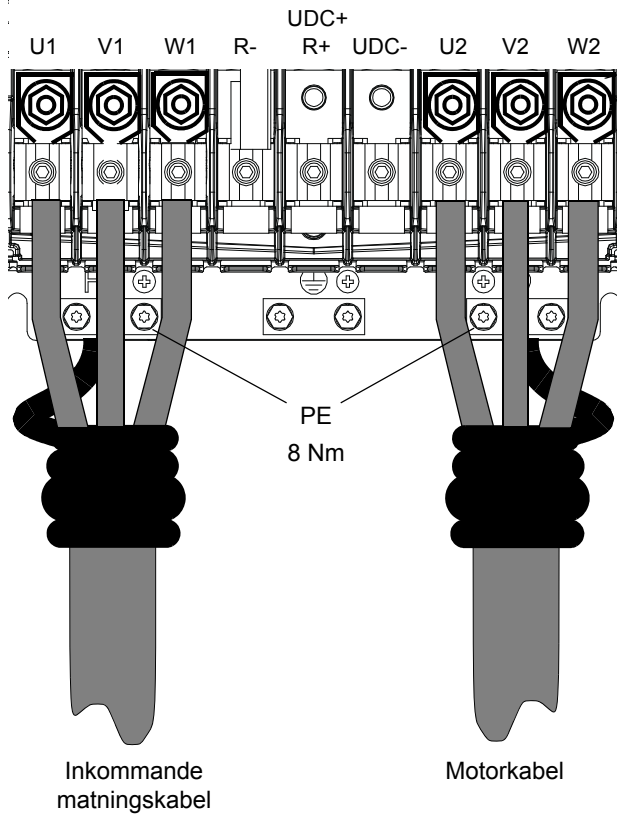

- Anslut ledaren till plinten. Dra åt insexskruven till 20...40 Nm
- Anslut plinten till frekvensomriktaren. Dra åt till 30...44 Nm



WARNING! Om ledararean understiger 95 mm² (3/0 AWG) måste en krimpkabelsko användas. En kabel med ledararea under 95 mm² (3/0 AWG) ansluten till denna plint kommer att lossna, vilket kan skada frekvensomriktaren.

Ledarareor som passar i kraftplintarna

Omriktartyp ACS850-04...	Ledararea
-103A-5, -144A-5	6 ... 70 mm ²
-166A-5...-290A-5	95 ... 240 mm ²

Åtdragningsmoment

Frekvens- omriktartyp ACS85004-04...	Kraftanslutningar	PE
	Nm	Nm
-103A-5, -144A-5	15	15
-166A-5...-290A-5	Kabelskoinstallation 30...44 (22...32)	8
	Insexskruv 20...40 (15...30) Skruvplintinstallation 30...44 (22...32)	8

Installation av styrkablar

Grundläggande I/O-krettschema

Noter:

Grundläggande inställning med ACS850 Standardmjukvara (tillämpningsmakrot Fabrik).

*Total maximal ström: 200 mA

Visade anslutningar är endast exempel.

För bygling, se text.

Ledarareor och åtdragningsmoment:

XPOW, XRO1, XRO2, XRO3, XD24:

0,5 ... 2,5 mm² (24...12 AWG).

Åtdragningsmoment: 0,5 Nm

XDI, XDIO, XAI, XAO, XD2D, XSTO:

0,5 ... 1,5 mm² (28...14 AWG). Moment:

0,3 Nm

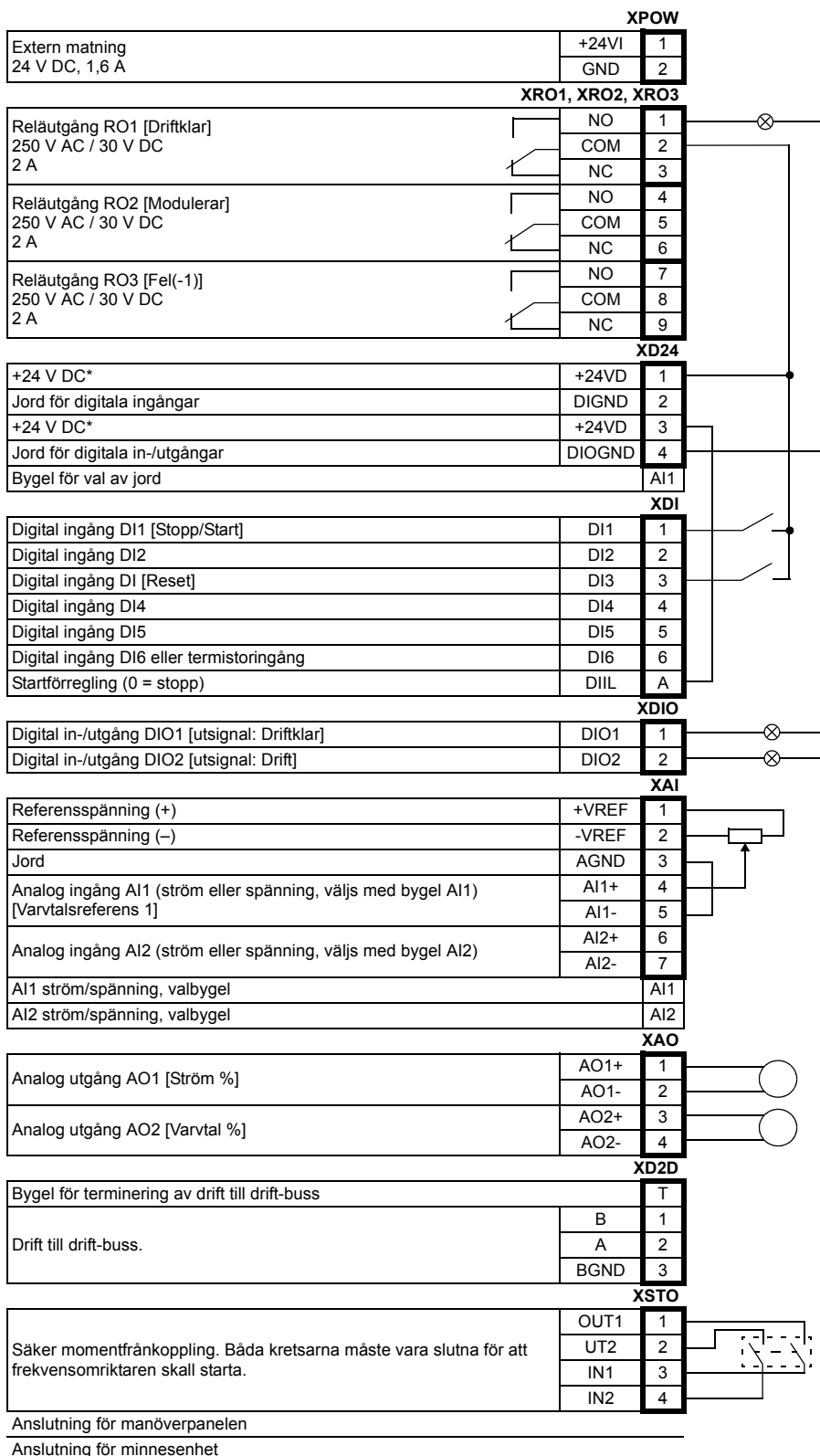
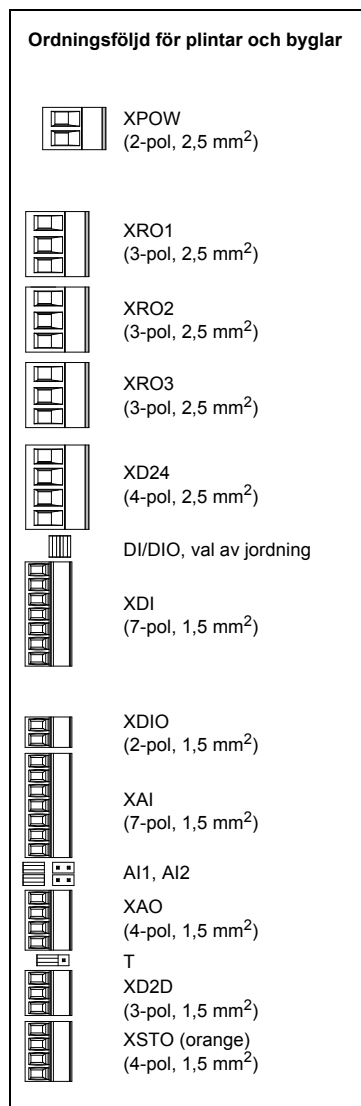

Byglar på styrenheten: DI/DIO jordningsomkopplare (placerad mellan XD24 och XDI) – Avgör om DIGND (jord för de digitala ingångarna DI1...DI5) är flytande eller kopplad till DIOGND (jord för DI6, DIO1 och DIO2). Om DIGND flyter skall den gemensamma nollan för DI1...DI5 anslutas till XD24:2. Den gemensamma nollan kan vara antingen GND eller V_{cc} eftersom DI1...DI5 är av NPN/PNP-typ.

DIGND flyter DIGND kopplad till DIOGND

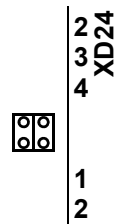
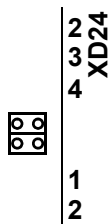

AI1 – Avgör om analog ingång AI1 används som ström- eller spänningsingång.

Ström

Spänning

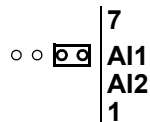
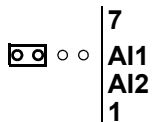

AI2 – Avgör om analog ingång AI2 används som ström- eller spänningsingång.

Ström

Spänning

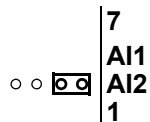
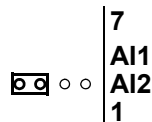

T - Terminering av drift till drift-buss. Måste vara satt till läge ON när frekvensomriktaren är sista enheten på bussen.

Terminering ON

Terminering OFF



Fortsätt med idrifttagningen enligt instruktionerna i aktuell *Snabbguide*.

Montering av kabelöverfallsplåt

Kabelöverfallsplåten kan monteras på över- eller underdelen av styrenheten JCU.

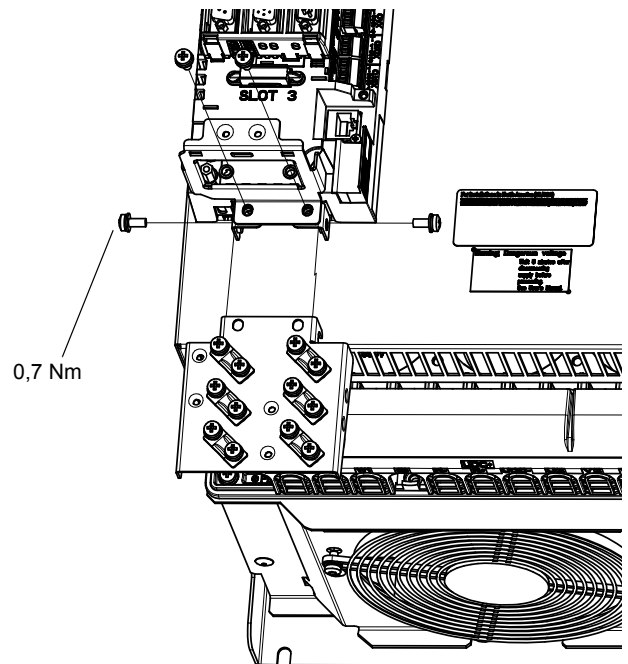

Förläggning av styrkablar

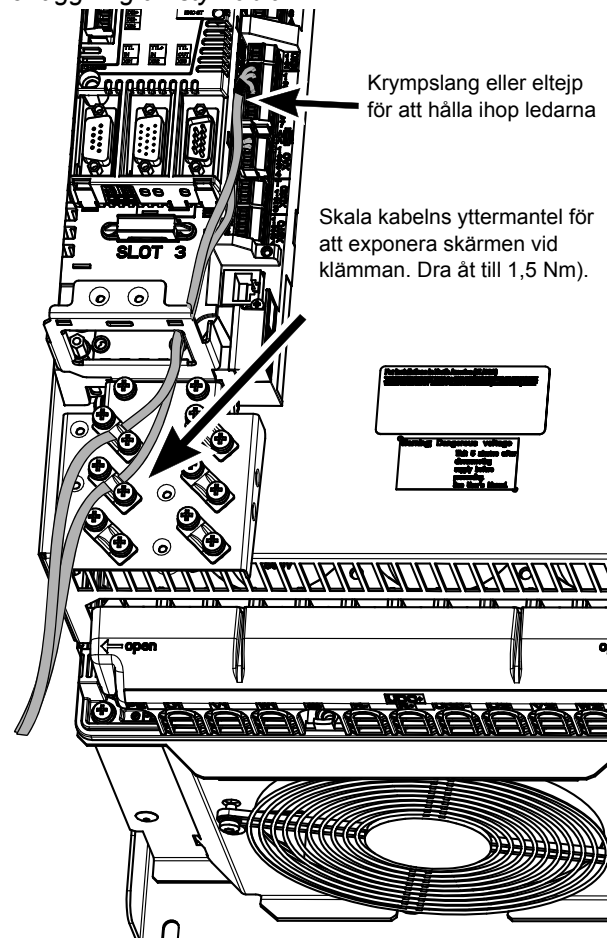

Tekniska data

UL-checklista

- ACSM850-04 är en frekvensomriktare med kapslingsklass IP20 (UL, öppen typ) för användning i kontrollerat inomhusklimat med uppvärmning. Frekvensomriktaren skall installeras i miljö med ren luft i enlighet med sin kapslingsklass. Kyl luften skall vara ren, utan frätande eller ledande partiklar. Se *Hårdvaruhandledningen* för detaljerad specifikation.
- Max tillåten omgivningstemperatur är 40°C vid märkström. Strömmen stämplas ner inom temperaturområdet 40 till 55°C.
- Frekvensomriktaren lämpar sig för användning i kretsar med matningskapacitet upp till 100 000 A rms symmetriskt, 500 V max.
- Kablarna i motorkretsen måste vara klassade för minst 75°C i UL-normerade installationer.
- Nätkabeln måste skyddas med säkringar eller brytare. Lämpliga IEC- (klass gG) och UL- (klass T) säkringar listas i *Tekniska data* i *Hårdvaruhandledningen*. För val av lämpliga brytare, kontakta ABB.
- Vid installation i USA måste grenledningsskydd tillhandahållas i enlighet med National Electrical Code (NEC) och eventuella lokala föreskrifter. För att uppfylla detta krav, använd UL-klassificerade säkringar.
- Vid installation i Kanada måste det finnas grenledningsskydd i enlighet med Canadian Electrical Code och eventuella lokala föreskrifter. För att uppfylla detta krav, använd UL-klassificerade säkringar.
- Frekvensomriktaren erbjuder överbelastningsskydd i enlighet med National Electrical Code (NEC). Se aktuell *Beskrivning av systemprogramvara* för information om inställning av överbelastningsskydd.

Hızlı kurulum kılavuzu – ACS850-04

Kılavuz hakkında

Bu kılavuz, ACS850-04 sürücü modülünün (55 - 200 kW) mekanik ve elektrik donanımı hakkında temel bilgiler içermektedir. Belgelerin tamamı için bkz. *ACS850-04 Sürücü Modülleri (55...200 kW, 60...200 hp) Donanım Kılavuzu* (kod: 3AUA0000045487 [İngilizce]).

Güvenlik talimatları



UYARI! Sürücünün elektrik tesisatı kurulumu ve bakım işleri yalnızca yetkili elektrikçiler tarafından yapılmalıdır.

Sürücü, fren kıyıcı devresi, motor kablosu ve motor üzerinde sürücüde elektrik varken kesinlikle çalışmayın. Mutlaka ölçüm yaparak gerilim bulunmadığından emin olun.

Döner sabit mıknatıslı motor tehlikeli seviyede gerilim üretebilir. Sürücüye sabit mıknatıslı motora bağlı sürücü sistemi üzerinde işlem gerçekleştirilmeden önce motor şaftını mutlaka mekanik olarak kilitleyin.

Mekanik kurulum



UYARI! Eğer sürücü IT güç sistemine bağlı ise (topraklanmamış ya da yüksek dirençli topraklanmış [30 ohm'un üzerinde] güç sistemi), sürücünün dahili EMC filtresinin bağlantısı kesilmelidir. Bu işlem sürücünün mekanik kurulumu yapılmadan önce gerçekleştirilmelidir. Ayrıntılı talimatlar için bkz. *Donanım Kılavuzu*.

Sürücü modülünü dört vidayla duvara sabitleyin.

Güç kablolarının bağlanması

Bağlantı şeması

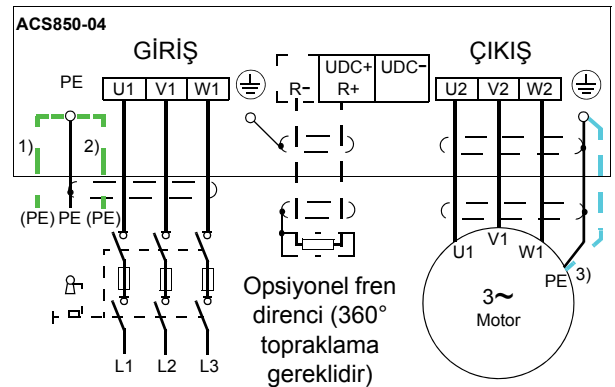

Notlar:

- Blendajsız veya asimetrik olarak oluşturulmuş motor kablosu kullanmayın. Ayrıca, besleme (giriş) kablosu olarak blendajlı kablo kullanılması önerilir.

- Eğer blendajlı besleme (giriş) kablosu kullanılıyorsa ve blendajın iletkenliği faz iletkeninin iletkenliğinin %50'sinden daha azsa, topraklama iletkeni (1) veya ayrı bir PE kablosu (2) bulunan bir kablo kullanın.

- Motor kablosu için, blendajın iletkenliği faz iletkeninin iletkenliğinin %50'sinden daha azsa ve kablunun simetrik toprak iletkenleri yoksa, ayrı bir topraklama kablosu (3) kullanın.

İletken ekran dışında motor kablosunda simetrik olarak oluşturulmuş toprak iletkeni varsa bunu sürücü ve motor uçlarındaki toprak konnektörlerine bağlayın.

Bağlantı prosedürü

Kablo bağlantısı örnekleri aşağıda verilmiştir. Sıkma momentleri 71. sayfada ve metnin uygun kısımlarında verilmiştir.

- Ana terminalleri kapatan plastik korumayı kaldırın. Bir tornavidayla köşesinden kaldırın.
- Güç kablolarının ve ayrı topraklama iletkenlerinin bükümlü blendajlarını sürücü modülünün topraklama terminaline bağlayın.
- Besleme kablosu faz iletkenlerini U1, V1 ve W1 terminallerine, motor kablosu faz iletkenlerini ise U2, V2 ve W2 terminallerine bağlayın. Önerilen bantlama uzunluğu E0 kasa tipi için 16 mm (0,63") ve E kasa tipi için 28 mm (1,1") şeklindedir.
- Sürücü modülünün dışında kabloları mekanik olarak sabitleyin.
- Güç kablolarına yer açmak amacıyla döşenen kablolar için şeffaf plastik muhafaza üzerinde delikler açın. Muhafazayı terminallere bastırın.
- Güç kablolarının diğer uçlarını bağlayın. Güvenliği sağlamak için toprak iletkenlerinin bağlantısına özellikle dikkat edin.

Kasa tipi E: Kablo pabucu takma (16 - 70 mm² [AWG6 - AWG2/0] kablolar)

Bant veya ısı korumasıyla kablo pabuçlarının uçlarını yalıtın 30...44 N·m
(22...32 lbf·ft)

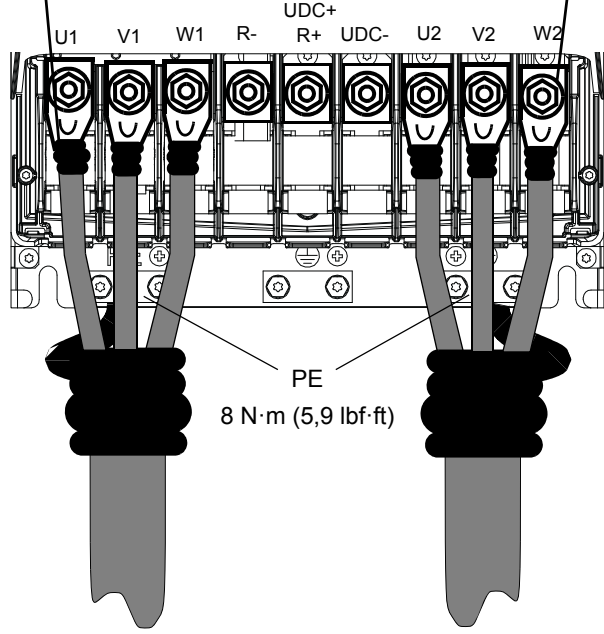

Giriş besleme kablosu

Motor kablosu

Kablo bağlantı örnekleri

Kasa tipi E0: Vidalı terminal takma

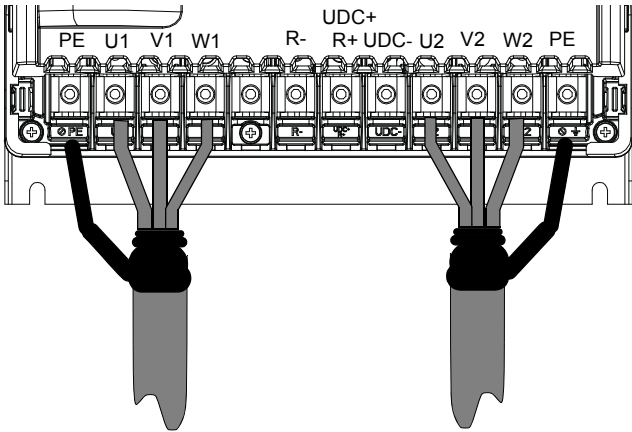

Giriş besleme kablosu

Motor kablosu

Kasa tipi E: Vidalı terminal takma (95 - 240 mm² [AWG3/0 - AWG500] kablolar)

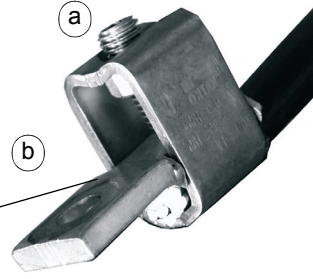
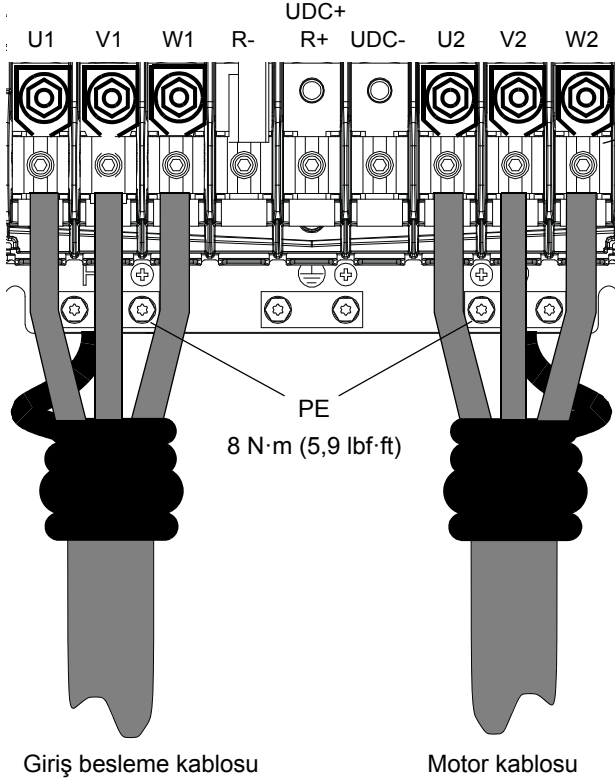

- Kabloyu terminale bağlayın. Allen vidayı 20...40 N·m (15...30 lbf·ft) ile sıkın.
- Terminali sürücüye basın. 30...44 N·m (22...32 lbf·ft) ile sıkın.



UYARI! Kablo boyutu 95 mm² (3/0 AWG) değerinden küçükse, kıvrımlı pabuç kullanılmalıdır. Terminale boyutu 95 mm² (3/0 AWG) değerinden küçük bir kablo bağlanırsa gevşer ve sürücüye hasar verebilir.

Güç terminallerine uygun kablo boyutları

Sürücü tipi ACS850-04...	Kablo boyutu
-103A-5, -144A-5	6 ... 70 mm ²
-166A-5...-290A-5	95 ... 240 mm ²

Sıkma momentleri

Sürücü tipi ACS850-04...	Güç terminalleri	
	N·m (lbf·ft)	PE N·m (lbf·ft)
-103A-5, -144A-5	15 (11)	15 (11)
-166A-5...-290A-5	Kablo pabuçu takma 30...44 (22...32)	8 (5,9)
	Allen vida 20...40 (15...30) Vidalı terminal takma 30...44 (22...32)	8 (5,9)

Kontrol kablolarının bağlanması

Varsayılan I/O bağlantı şeması

Notlar:

[ACS850 standart kontrol programı (Fabrika makrosu) ile varsayılan ayar.

*Toplam maksimum akım: 200 mA

Gösterilen kablolar yalnızca demonstrasyon amaçlıdır.

Jumper ayarları için metne bakın.

Kablo boyutları ve sıkma momentleri:

XPOW, XRO1, XRO2, XRO3, XD24:
0.5 ... 2.5 mm² (24...12 AWG). Moment:
0,5 N·m (5 lbf·inç)

XDI, XDIO, XAI, XAO, XD2D, XSTO:
0.5 ... 1.5 mm² (28...14 AWG). Moment:
0,3 N·m (3 lbf·inç)

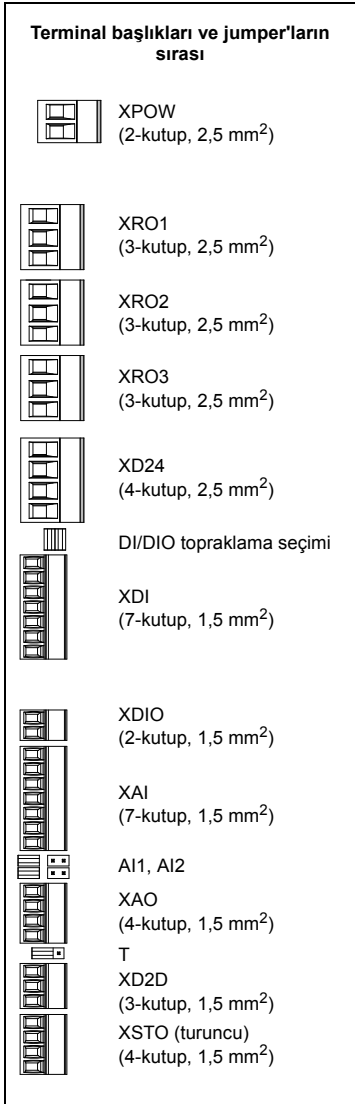

XPOW		
Harici güç girişi	+24VI	1
24 V DC, 1.6 A	GND	2

XRO1, XRO2, XRO3		
Röle çıkışı RO1 [Hazır] 250 V AC / 30 V DC 2 A	NO	1
	COM	2
	NC	3
Röle çıkışı RO2 [Modülasyonda] 250 V AC / 30 V DC 2 A	NO	4
	COM	5
	NC	6
Röle çıkışı RO3 [Hata(-1)] 250 V AC / 30 V DC 2 A	NO	7
	COM	8
	NC	9

XD24		
+24 V DC*	+24VD	1
Dijital giriş toprak hattı	DIGND	2
+24 V DC*	+24VD	3
Dijital giriş/çıkış toprak hattı	DIOGND	4
Toprak seçim jumper'ı		AI1

XDI		
Dijital giriş DI1 [Stop/Start]	DI1	1
Dijital giriş DI2	DI2	2
Dijital giriş DI3 [Reset]	DI3	3
Dijital giriş DI4	DI4	4
Dijital giriş DI5	DI5	5
Dijital giriş DI6 veya termistör girişi	DI6	6
Start kilidi (0 = Stop)	DIIL	A

XDIO		
Dijital giriş/çıkış DIO1 [Çıkış: Hazır]	DIO1	1
Dijital giriş/çıkış DIO2 [Çıkış: Çalışıyor]	DIO2	2

XAI		
Referans gerilim (+)	+VREF	1
Referans gerilim (-)	-VREF	2
Toprak	AGND	3
Analog giriş AI1 (Akım veya gerilim, jumper AI1 ile seçilebilir) [Hız referansı 1]	AI1+	4
	AI1-	5
Analog giriş AI2 (Akım veya gerilim, jumper AI2 ile seçilebilir)	AI2+	6
	AI2-	7
AI1 akım/gerilim seçim jumper'ı		AI1
AI2 akım/gerilim seçim jumper'ı		AI2

XAO		
Analog çıkış AO1 [Akım %]	AO1+	1
	AO1-	2
Analog çıkış AO2 [Hız %]	AO2+	3
	AO2-	4

XD2D		
Sürücü - sürücü bağlantısı sonlandırma jumper'ı	B	1
	A	2
Sürücü - sürücü bağlantısı.	BGND	3

XSTO		
Güvenli Moment Kapatma. Sürücünün başlaması için her iki devre kapatılmalıdır.	OUT1	1
	OUT2	2
	IN1	3
	IN2	4

Kontrol paneli bağlantısı		
Bellek ünitesi bağlantısı		

Kumanda ünitesi üzerindeki jumper'lar: DI/ DIO topraklama seçicisi (XD24 ve XDI arasında bulunur) - DIGND'nin (DI1...DI5 dij. girişleri için topraklama) dalgalanıp dalgalanmadığını veya DIOGND'ye (DI6 dij. girişi ve DIO1 ve DIO2 dij. giriş/çıkışlar için toprak) bağlı olup olmadığını belirler. DIGND dalgalanırsa, DI1...DI5 ortak girişlerinin XD24:2'ye bağlanması gerekir. DI1...DI5 ortak girişleri NPN/PNP tipi olduğundan, ortak hat GND veya Vcc olabilir.

DIGND dalgalanması DIOGND'ye bağlı DIGND

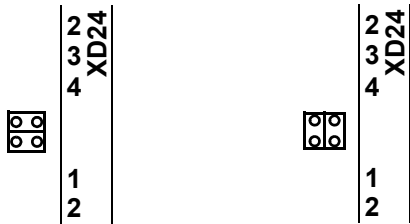

AI1 - Analog giriş AI1'in akım veya gerilim girişi olarak kullanımını belirler.

Akım

Gerilim



AI2 - Analog giriş AI2'nin akım veya gerilim girişi olarak kullanımını belirler.

Akım

Gerilim



T - Sürücü - sürücü bağlantı sonlandırma. Sürücü bağlantıdaki son ünite ise AÇIK konumunda olmalıdır.

Sonlandırma AÇIK

Sonlandırma KAPALI



Uygun *Hızlı Kurulum Kılavuzundaki* talimatlara göre sürücü devreye alma ile devam edin.

Kelepçe plakasının monte edilmesi

Kelepçe plakası JCU Kumanda Ünitesinin üzerine veya altına bağlanabilir.

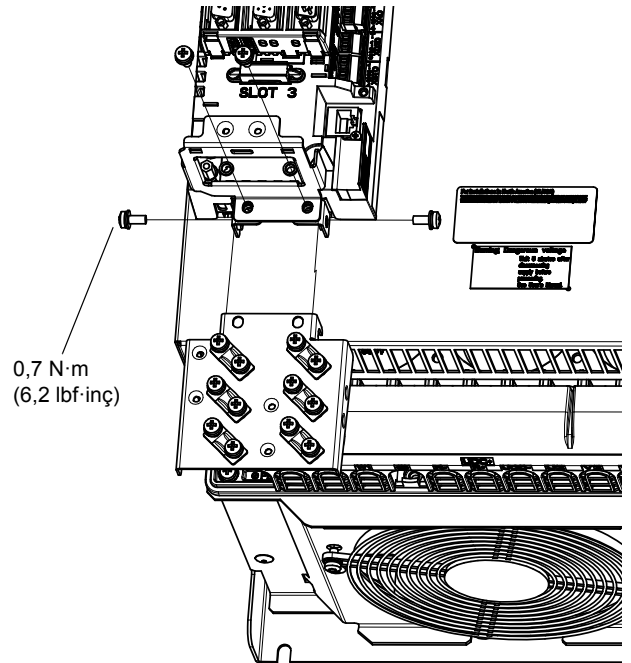

Kontrol kablolarının yönlendirilmesi

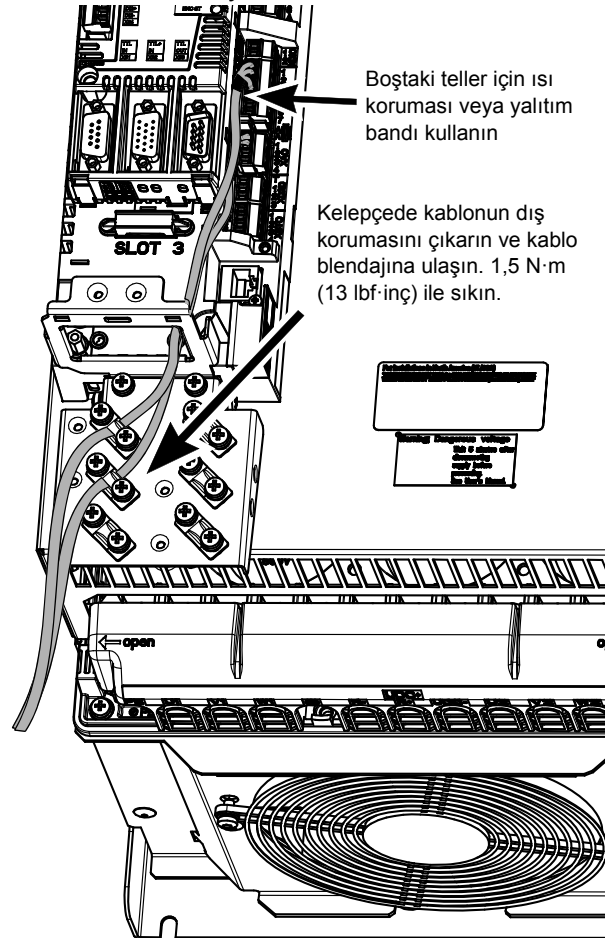

Teknik veriler

UL kontrol listesi

- ACS850-04; ısıtmalı, kapalı, kontrollü alanlarda kullanılan bir IP20 (UL açık tip) sürücüdür. Sürücü muhafaza sınıfına uygun temiz hava koşullarında kurulmalıdır. Soğutma havasının temiz, korozif materyallerden ve elektrik açısından iletken tozlardan arınmış olması gerekir. Ayrıntılı özellikler için bkz. *Donanım Kılavuzu*.
- Nominal akımda maksimum ortam hava sıcaklığı 40 °C'dir (104 °F). Akım 40'tan 55 °C'ye düşer (104'ten 131 °F'ye).
- Sürücü, maksimum 500 V'luk 100.000 rms simetrik amperden fazla sağlama kapasitesi olmayan devrede kullanım için uygundur.
- Motor devresinde bulunan kablolar UL uyumlu tesisatlarda en az 75 °C (167 °F) için uygun olmalıdır.
- Giriş kablosu sigortalarla ya da devre kesicilerle korunmalıdır. Uygun IEC (sınıf gG) ve UL (sınıf T) sigortaların listesi, *Donanım Kılavuzu*'nun *Teknik veriler* bölümünde verilmiştir. Uygun devre kesiciler için yerel ABB temsilciniz ile iletişim kurun.
- ABD'de kurulum için, dal devresi koruması, Ulusal Elektrik Yasası (NEC) ve tüm yürürlükteki yerel yasalarla uygun olarak sağlanmalıdır. Bu gereksinimi karşılamak için UL sınıfı sigortalar kullanın.
- Kanada'da gerçekleştirilecek kurulumlar için dal devresi koruması Kanada Elektrik Yasalarına ve yürürlükteki tüm yerel yasalara uygun olarak sağlanmalıdır. Bu gereksinimi karşılamak için UL sınıfı sigortalar kullanın.
- Sürücü, Ulusal Elektrik Yasasına (NEC) uygun aşırı yük koruması sağlamaktadır. Aşırı yük koruması ayarları için uygun *Yazılım Kılavuzuna* bakın.

快速安装指南 – ACS850-04

关于本指南

本指南包含了 ACS850-04 传动模块 (55 至 200 kW) 机械和电气安装需遵循的基本步骤。完整手册请参阅 *ACS850-04 传动模块 (55...200 kW, 60...200 hp) 硬件手册* (编号: 3ABD00030508 [中文])。

安全须知



警告! 只有具备资质的电气工程师才可以对传动进行安装和维护。

不能对带电的传动、制动斩波电路、电机电缆或电机进行任何操作。开始工作前，要确认传动没有危险电压。

旋转的永磁电机可以产生危险电压。在永磁电机与传动连接之前，以及在传动系统连接到永磁电机并对其进行操作之前，将电机轴机械锁死。

机械安装



警告! 如果传动被连接到 IT 功率系统上 (也就是接地, 或高电阻接地 [大于 30 ohms] 功率系统), 必须断开内部 EMC 滤波器的连接。这项操作必须在传动机械安装之前进行, 详细信息, 请参阅 *硬件手册*。

用四个螺丝将传动模块紧固在墙上。

安装功率电缆

接线图

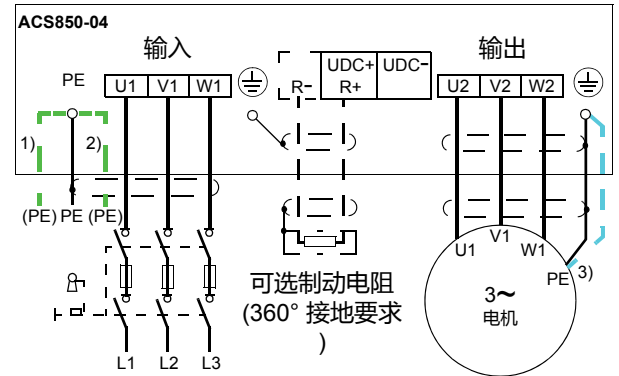

注意:

- 不要使用无屏蔽层或非对称的电机电缆。建议使用带屏蔽层的电缆作为供电 (输入) 电缆。
- 如果使用了带屏蔽层的电压 (输入) 电缆, 且其屏蔽层的导电率低于相导体导电率的 50%, 那么必须使用带接地导体的电缆 (1) 或使用独立的 PE 电缆 (2)。
- 对于电机布线, 如果电缆屏蔽层的导电率低于相导体导电率的 50%, 并且电缆没有对称接地导体, 请使用单独的接地电缆 (3)。

除了导体屏蔽层之外, 如果电机电缆还配有对称接地导体, 在传动和电机的终端将对称接地导体连接到接地连接器上。

连接过程

下为布线示例：

请参阅第 77 页，有关紧固力矩的相应文字介绍：

- 移除主端子上的塑料盖板。用螺丝刀将其从角落处拉出。
- 将功率电缆的螺旋盖板和独立的接地导体连接到传动模块的接地端子。
- 将供电电缆的相导体连接到 U1, V1 和 W1 端子上，电机电缆的相导体连接到 U2, V2 和 W2 端子上。尺寸 E0 推荐剥线长度为 16 mm (0.63")，尺寸 E 推荐剥线长度为 28 mm (1.1")。
- 对传动模块的外部电缆进行机械保护。
- 在透明塑料盖板剪洞安装电缆，以适应功率电缆。压紧端子上的盖板。
- 连接功率电缆的另一端。为确保安全，要特别注意接地导体的连接。

布线示例

外形尺寸 E0：螺丝端安装

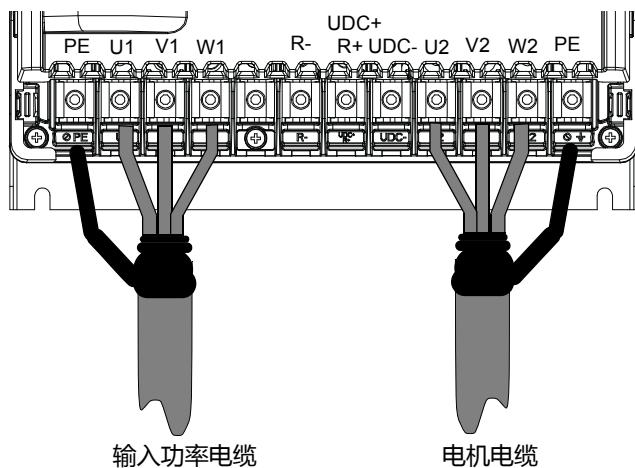

外形尺寸 E: 电缆接线头安装 (16 至 70 mm² [AWG6 至 AWG2/0] 的电缆)

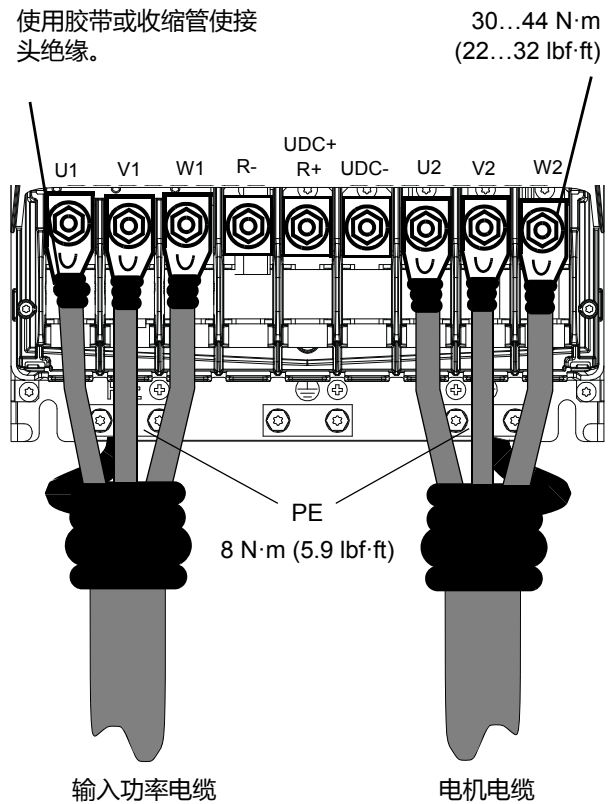

外形尺寸E: 螺丝端安装 (95 至 240 mm² [AWG3/0 to 500MCM] 的电缆)

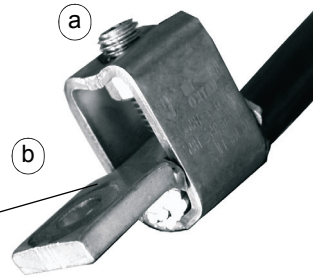
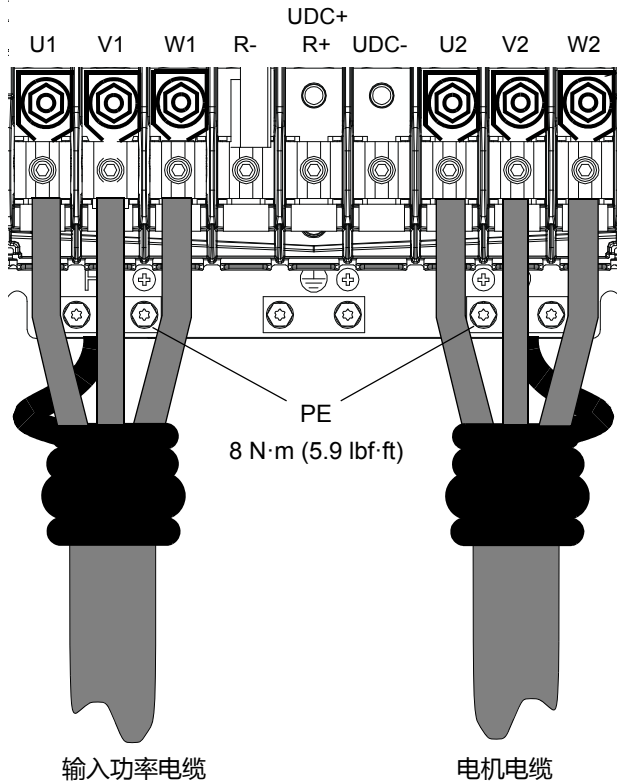

- 将电缆连接到端子。紧固六角固定螺丝至 20...40 N·m (15...30 lbf·ft)。
- 将端子连接到传动单元。紧固至 30...44 N·m (22...32 lbf·ft)。



注意! 如果电线尺寸少于 95 mm² (3/0 AWG), 那么必须使用紧耳盖, 如果连接到该端子的电线尺寸少于 5 mm² (3/0 AWG), 那么会发生松动或导致变频器损坏。

功率端子接受的电线尺寸：

传动型号 ACS850-04...	电线尺寸
-103A-5, -144A-5	6 ... 70 mm ²
-166A-5...-290A-5	95 ... 240 mm ²

紧固力矩

传动型号 ACS850-04...	功率端子	PE
	N·m (lbf·ft)	N·m (lbf·ft)
-103A-5, -144A-5	15 (11)	15 (11)
-166A-5...-290A-5	电缆接头安装 30...44 (22...32)	8 (5.9)
	六角固定螺丝 20...40 (15...30) 螺丝端安装 30...44 (22...32)	8 (5.9)

安装控制电缆

缺省 I/O 连接图

注意：
 [ACS850 标准控制程序的缺省设置 (工厂宏)。
 * 总最大电流：200 mA
 接线图仅供演示说明。
 关于跳线设置，请参见：
电缆尺寸和紧固力矩：
 XPOW, XRO1, XRO2, XRO3, XD24:
 0.5 ... 2.5 mm² (24...12 AWG). 转矩：
 0.5 N·m (5 lbf·in)
 XDI, XDIO, XAI, XAO, XD2D, XSTO:
 0.5 ... 1.5 mm² (28...14 AWG). 转矩：
 0.3 N·m (3 lbf·in)

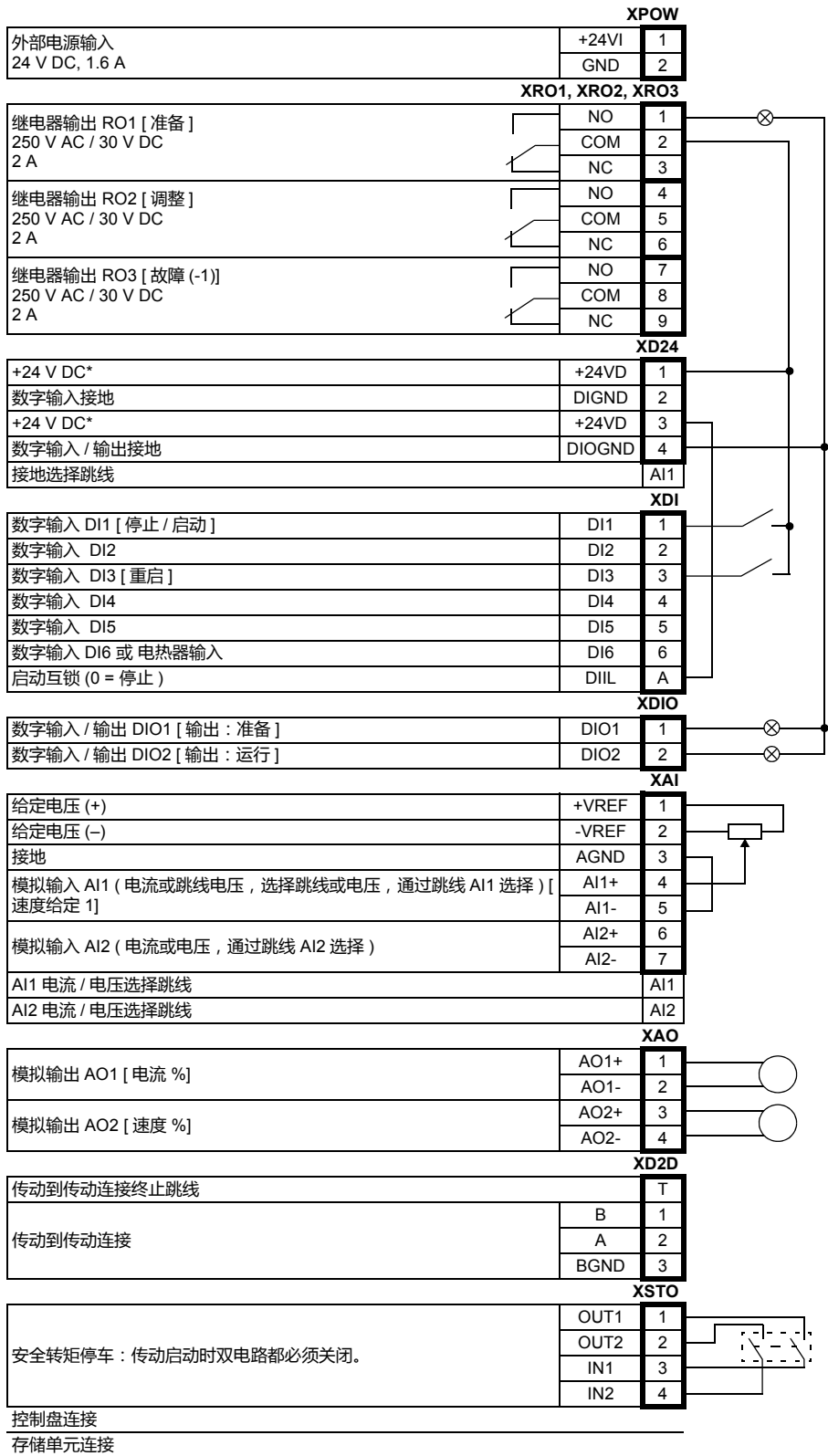
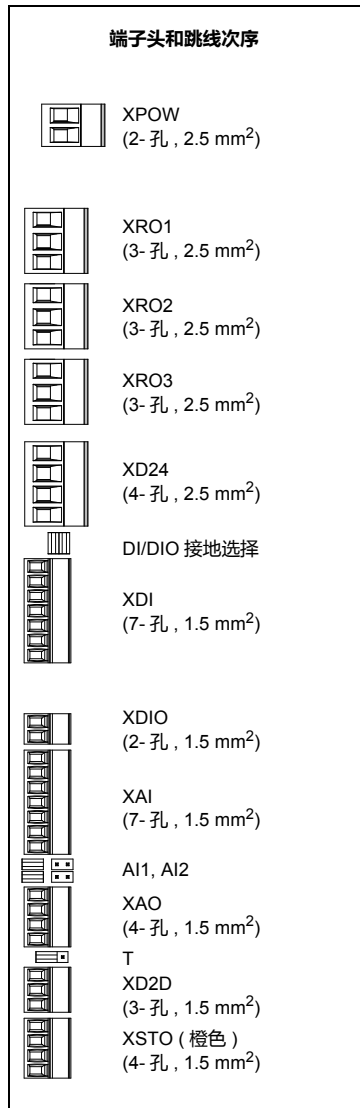

控制单元的跳线：DI/DIO 接地选择器（位于 XD24 和 XDI）—测定是否 DIGND（DI1...DI5 的接地端）浮动，或者是否已连接到 DIOGND（DI6, DIO1 和 DIO2 的接地端）。如果 DIGND 浮动，DI1...DI5 的公共端应该连接到 XD24:2。由于 DI1...DI5 为 NPN/PNP 类型，所以公共端可以为 GND 或 V_{CC} 中的任意一个。

DIGND 浮动

DIGND 连接到 DIOGND

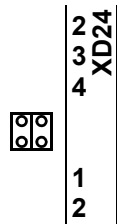
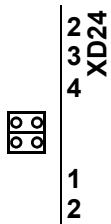

AI1 – 用来选择模拟输入 AI1 的输入信号是电流信号还是电压信号。

电流

电压

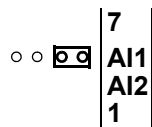
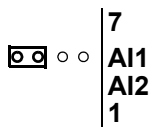

AI2 – 用来选择模拟输入 AI2 的输入信号是电流信号还是电压信号。

电流

电压

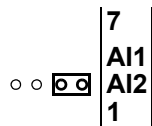
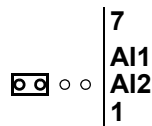

T – 传动对传动连接的链路终端。当传动是最后一个单元时，必须设置到 ON 位置。

ON

OFF



关于传动的启动请参考快速启动指南中的相关介绍。

安装电缆固定夹

电缆固定夹可以安装在 JCU 控制单元的顶部或底部。

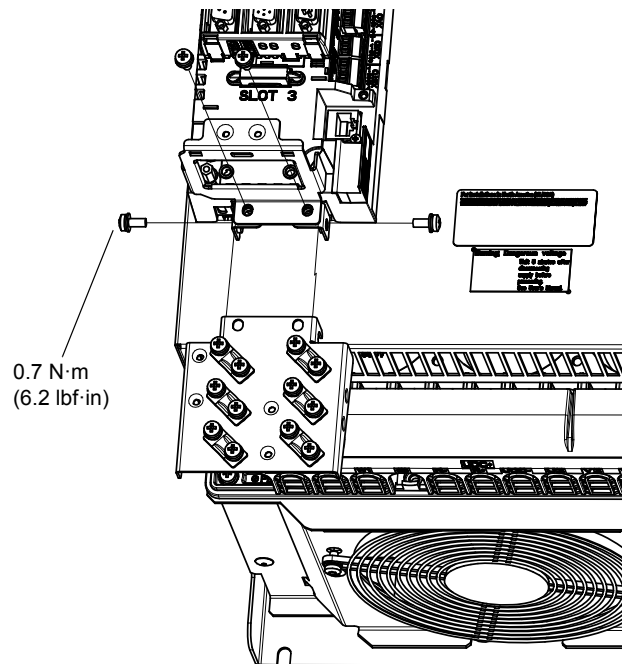

控制电缆布线

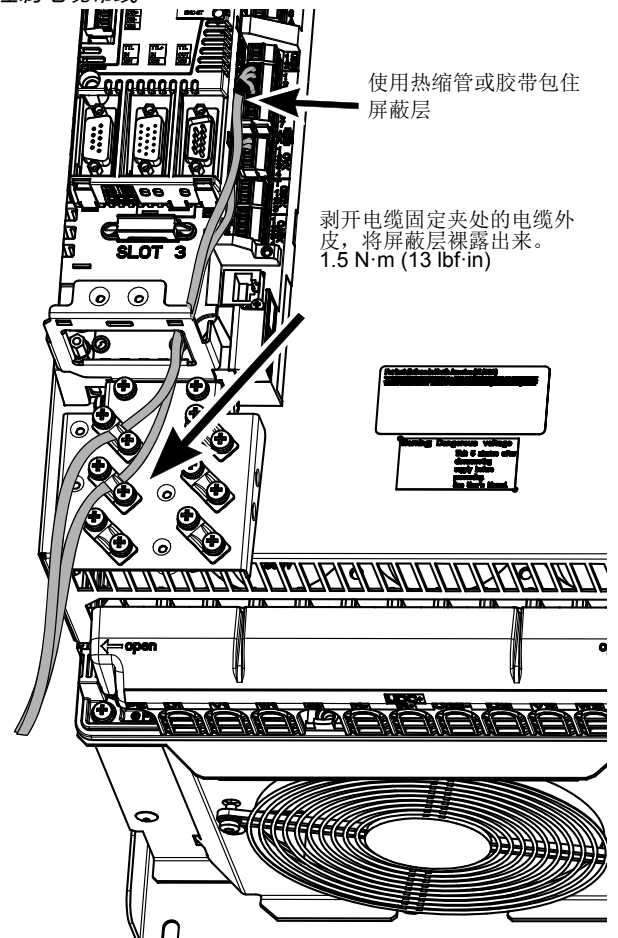

使用热缩管或胶带包住屏蔽层

剥开电缆固定夹处的电缆外皮，将屏蔽层裸露出来。
1.5 N·m (13 lbf·in)

技术数据

UL 清单

- ACS850-04 是 IP20 (UL 开路类型) 防护等级的传动，用于室内温度可控的环境中。传动必须安装在符合要求的清洁环境中。冷却空气必须干净，并且没有腐蚀性气体和导电灰尘。详细说明请参见 *硬件手册*。
- 在额定电流下，最高环境空气温度为 40 °C (104 °F)。在 40 至 55 °C (104 至 131 °F) 温度下，电流需要降容。
- 传动单元适用于电流有效值不超过 100,000 A，最大电压 500 V 的电路容量。
- 遵照 UL 认证的安全要求，位于电机内部的电缆至少允许 75 °C (167 °F) 时降容。
- 输入电缆必须有熔断器或断路器保护。符合 IEC (gG) 和 UL (T) 的熔断器在 *硬件手册* 技术数据一章中列出。关于符合标准的断路器，请联系当地 ABB 代表处。
- 对于美国用户，按照国家电气法规 (NEC) 和任何适用的当地法规，必须提供支路保护设备。为了满足这一要求，请使用 UL 认证的熔断器。
- 对于加拿大用户，按照加拿大电气法规和各省法规的要求，必须提供支路保护设备。为了满足这一要求，请使用 UL 认证的熔断器。
- 传动提供符合美国国家电气法规 (NEC) 的过载保护功能。关于过载保护设置请参见相关 *硬件手册*。

Further information

Product and service inquiries

Address any inquiries about the product to your local ABB representative, quoting the type designation and serial number of the unit in question. A listing of ABB sales, support and service contacts can be found by navigating to www.abb.com/drives and selecting *Sales, Support and Service network*.

Product training

For information on ABB product training, navigate to www.abb.com/drives and select *Training courses*.

Providing feedback on ABB Drives manuals

Your comments on our manuals are welcome. Go to www.abb.com/drives and select *Document Library – Manuals feedback form (LV AC drives)*.

Document library on the Internet

You can find manuals and other product documents in PDF format on the Internet. Go to www.abb.com/drives and select *Document Library*. You can browse the library or enter selection criteria, for example a document code, in the search field.



3AJUA0000045488 Rev E
EFFECTIVE: 2012-08-16

ABB Oy

Drives
P.O. Box 184
FI-00381 HELSINKI
FINLAND
Telephone +358 10 22 11
Fax +358 10 22 22681
Internet www.abb.com/drives

ABB Inc.

Automation Technologies
Drives & Motors
16250 West Glendale Drive
New Berlin, WI 53151
USA
Telephone 262 785-3200
1-800-HELP-365
Fax 262 780-5135

ABB Beijing Drive Systems Co. Ltd.

No. 1, Block D, A-10 Jiuxianqiao Beilu
Chaoyang District
Beijing, P.R. China, 100015
Telephone +86 10 5821 7788
Fax +86 10 5821 7618
Internet www.abb.com/drives