

ABB Drives

Application guide

Safe torque off function for ACSM1, ACS850 and ACQ810 drives



3AFE68929814 Rev F
EN
EFFECTIVE: 2011-02-18

Table of contents

Table of contents	3
Basics	5
Program features, settings and diagnostics	7
Operation of the STO function and its diagnostics function	7
Diagnostic parameter	7
STO status indications	9
Monitoring the delay between the STO inputs	10
STO function activation and indication delays	10
Installation	11
Wiring principles	11
Single drive module with internal power supply	11
Single drive module with internal power supply, single channel	12
Single drive module with external power supply	12
Single drive module with external power supply, single channel	13
Multiple drive modules with internal power supply	14
Multiple drive modules with external power supply	15
Multiple drive modules with internal power supply, single channel	16
Multiple drive modules with external power supply, single channel	17
Start-up and validation	18
Validating the operation of a safety function	18
Authorized person	18
Acceptance test reports	18
Start-up checklist	19
Maintenance, fault tracing and diagnostics	20
Maintenance	20
Alarm messages generated by the drive	20
Fault messages generated by the drive	21
Technical data	22
STO components	22
STO safety relay type	22
STO cable	22
Data related to safety standards	23

Abbreviations24
TÜV certificate – ACSM125
TÜV certificate – ACS85026
TÜV certificate – ACQ81027
Further information29
Product and service inquiries29
Product training29
Providing feedback on ABB Drives manuals29
Document library on the Internet29

Basics

The drive supports the Safe torque off function according to standards EN 61800-5-2:2007; EN ISO 13849-1:2008, IEC 61508, IEC 61511:2004 and EN 62061:2005. The function also corresponds to an uncontrolled stop in accordance with category 0 of EN 60204-1 and the prevention of unexpected start-up of EN 1037.

The STO may be used where power removal is required to prevent an unexpected start. The function disables the control voltage of the power semiconductors of the drive output stage, thus preventing the inverter from generating the voltage required to rotate the motor (see diagram below). By using this function, short-time operations (like cleaning) and/or maintenance work on non-electrical parts of the machinery can be performed without switching off the power supply to the drive.

ACSM1

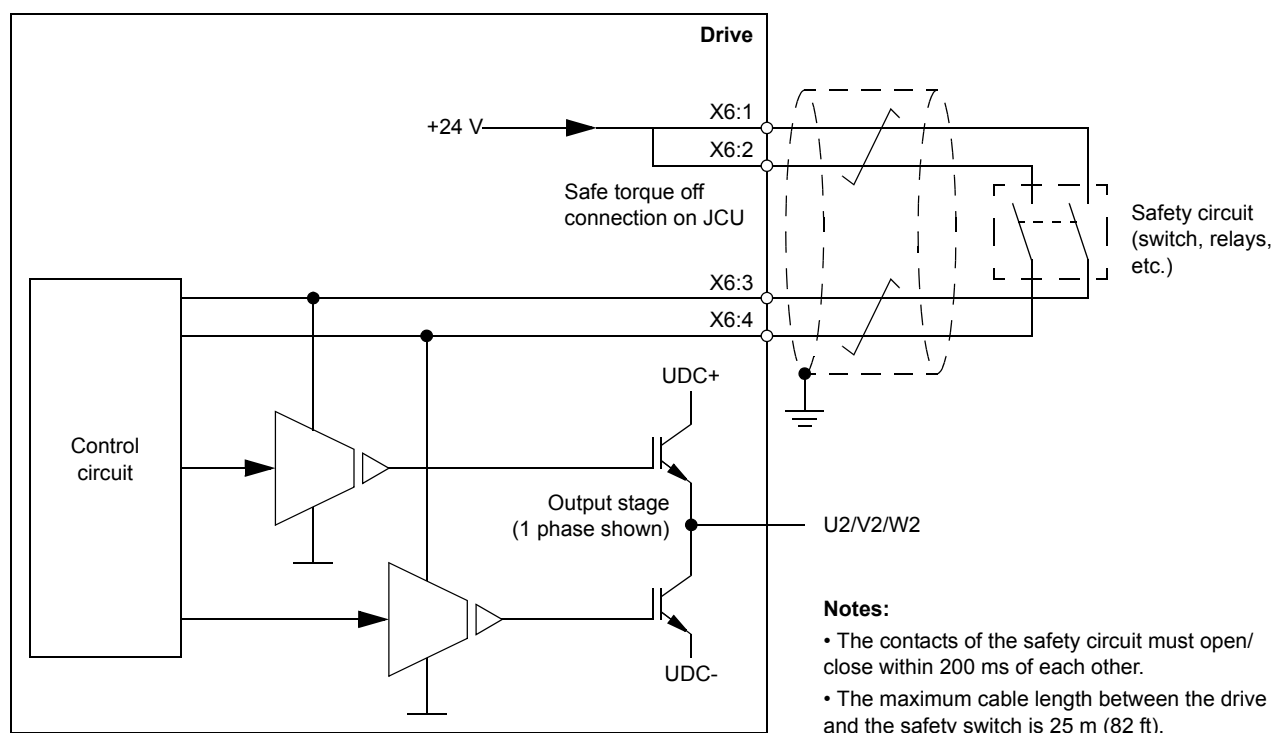

ACS850 and ACQ810

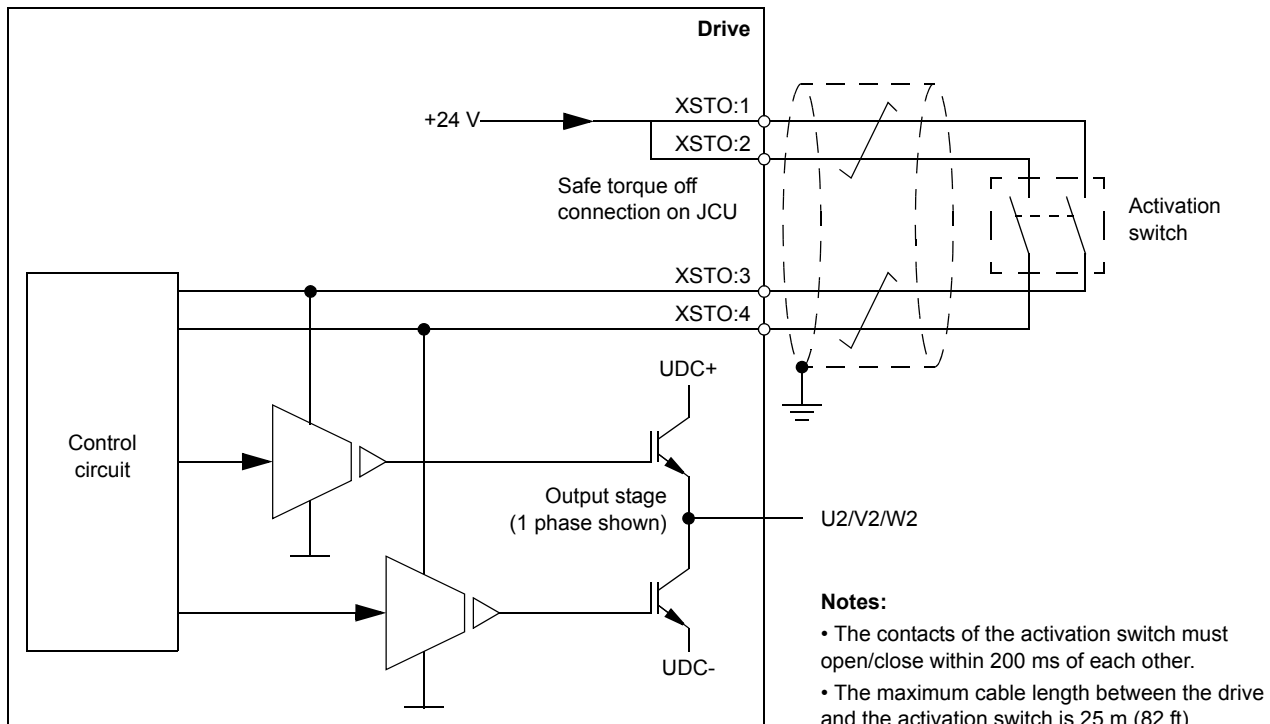

WARNING! The Safe torque off function does not disconnect the voltage of the main and auxiliary circuits from the drive. Therefore maintenance work on electrical parts of the drive or the motor can only be carried out after isolating the drive system from the main supply.

Note: It is not recommended to stop the drive by using the Safe torque off function. If a running drive is stopped by using the function, the drive will trip and stop by coasting. If this is not acceptable e.g. causes danger, the drive and machinery must be stopped using the appropriate stopping mode before using this function.

Note concerning permanent magnet motor drives in case of a multiple IGBT power semiconductor failure: In spite of the activation of the Safe torque off function, the drive system can produce an alignment torque which maximally rotates the motor shaft by $180/p$ degrees. p denotes the pole pair number.

Program features, settings and diagnostics

Operation of the STO function and its diagnostics function

When both STO inputs are energized, the STO function is in the standby state and the drive operates normally. If the STO inputs are de-energized, the STO function awakes, stops the drive and disables start. Start is possible only after the STO inputs have been energized, and any faults of the drive have been reset.

Diagnostic parameter

The way of operation of the STO diagnostics function is selected by a drive control program parameter. This parameter is *46.07 STO DIAGNOSTIC* for ACSM1 drives and *30.07 Sto diagnostic* for ACS850 and ACQ810 drives. By default, the drive trips whenever one or both of the two STO inputs is de-energized. This is appropriate when no external control is used and the STO inputs are constantly kept energized by short-circuiting them. When external STO control is taken into use, the user must change the setting to avoid unnecessary fault trips.

The table below describes the operation of the STO function in detail depending on:

- value of the diagnostic parameter (see section [Diagnostic parameter](#) on page 7)
- status of the STO inputs.

Value of diagnostic parameter	Status of STO inputs	How the STO operates	
		When drive is	STO function
Fault	De-energized	stopped or running	awakes and trips the drive. Fault code: F-0031.
	energized	stopped or running	is on standby. Drive operates normally.
	One energized, other de-energized ¹⁾	stopped or running	awakes and trips the drive. Fault code: F-0021 or F-0022.
Alarm	De-energized	stopped	awakes, disables start and generates an alarm. Alarm code: A-2003.
		running	awakes and trips the drive. Fault code: F-0031.
	energized	stopped or running	is on standby. Drive operates normally.
	One energized, other de-energized ¹⁾	stopped or running	awakes and trips the drive. Fault code: F-0021 or F-0022.
No	De-energized	stopped	awakes and disables start. No STO status indication (alarm, etc.).
		running	awakes and trips the drive. Fault code: F-0031.
	energized	stopped or running	is on standby. Drive operates normally.
	One energized, other de-energized ¹⁾	stopped or running	awakes and trips the drive. Fault code: F-0021 or F-0022.
Only Alarm	De-energized	stopped or running	awakes, disables start and generates an alarm. Alarm code: A-2003.
	One energized, other de-energized ¹⁾	stopped or running	awakes and trips the drive. Fault code: F-0021 or F-0022.

¹⁾ The operation delay between the inputs is excessive. See section [STO function activation and indication delays](#) on page 10.

STO status indications

Alarm and status bits	
ACSM1: 08.05 ALARM WORD 1 bit 4 ACS850: 08.05 Alarm word1 bit 4 ACQ810: 08.05 Alarm word1 bit 1	STO mode change
ACSM1: 06.02 STATUS WORD 2 bit 10 ACS850 and ACQ810: 06.02 Status word2 bit 10	STO status. 1: STO function active, drive start disabled. 0: STO function inactive, drive operation enabled.
Digital outputs	
ACSM1: 12.04 DIO1 OUT PTR 12.05 DIO2 OUT PTR 12.06 DIO3 OUT PTR ACS850 and ACQ810: 14.03 DIO1 out src 14.07 DIO2 out src	Selects a drive signal to be connected to digital output.
Relay outputs	
ACSM1: 12.12 RO1 OUT PTR ACS850: 14.42 RO1 src 14.45 RO2 src 14.48 RO3 src ACQ810: 14.42 RO1 src 14.45 RO2 src	Selects a drive signal to be connected to relay output.
Alarms and faults	
	See chapter Maintenance, fault tracing and diagnostics .

Monitoring the delay between the STO inputs

The STO function monitors the switching time difference between the STO inputs. If the time difference exceeds 200 ms, the drive trips on a fault. The fault indication depends on the value of diagnostic parameter: F-0031 with setting *Fault* or when the drive is running, F-0021 or F-0022 with setting *Alarm* or *No* when the drive is at the stopped state.

STO function activation and indication delays

STO mode ¹⁾ and drive status	STO activation and indication delays ^{2,3)}
STO mode: Any Drive status: Any	STO activation delay: < 1ms
STO mode: Any Drive status: Running	STO indication delay: < 20 ms
STO mode: Fault Drive status: Stopped	STO indication delay: < 20 ms
STO mode: No or Alarm Drive status: Stopped	STO indication delay: < 220 ms

1) Value of diagnostic parameter

2) STO activation delay = delay between energizing the STO relay and switching off the drive output bridge

3) STO indication delay = delay between energizing the STO relay and the digital output of the drive that indicates the STO status

Installation

Wiring principles

Wiring principles are shown in the diagrams below. See chapter [Technical data](#) for the cable specification and possible safety relay types.

Safe torque off connector is

- X6 in ACSM1 drives
- XSTO in ACS850 and ACQ810 drives.

AGND connector is

- X4:3 in ACSM1 drives
- XAI:3 in ACS850 and ACQ810 drives.

Single drive module with internal power supply

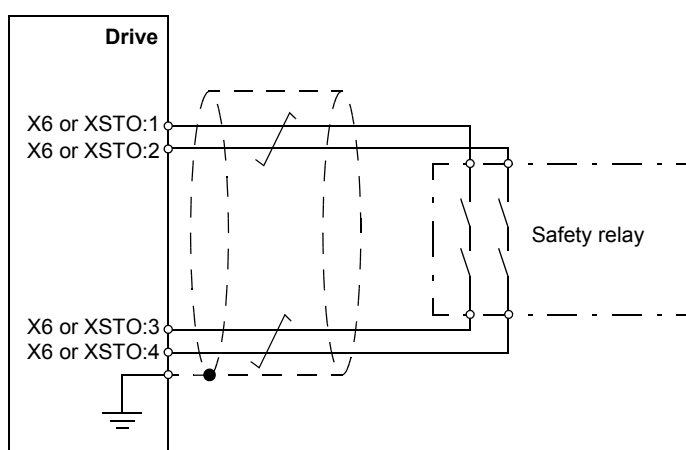

Single drive module with internal power supply, single channel

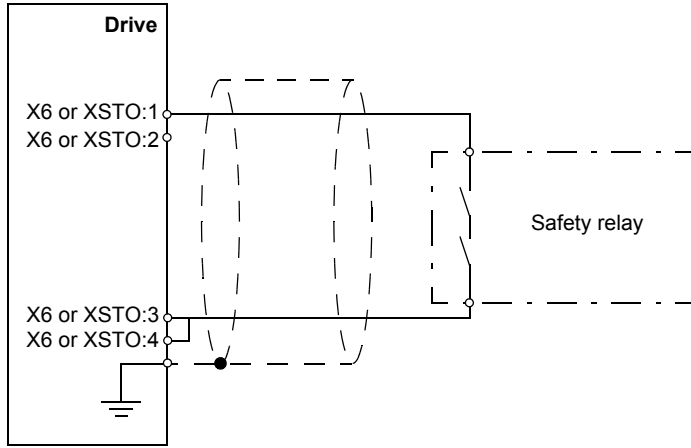

Single drive module with external power supply

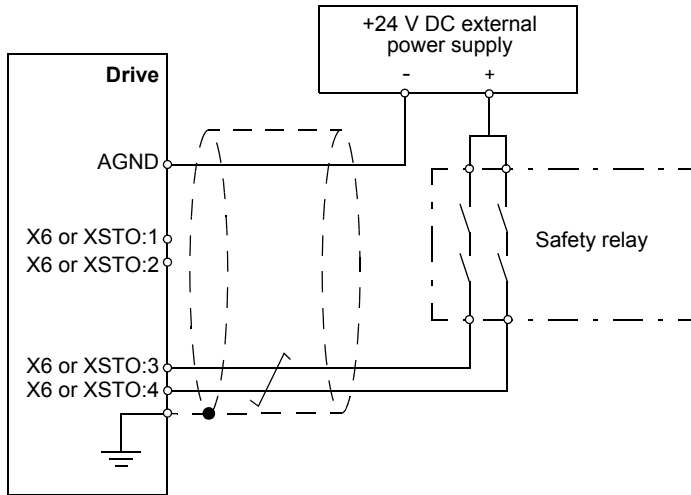

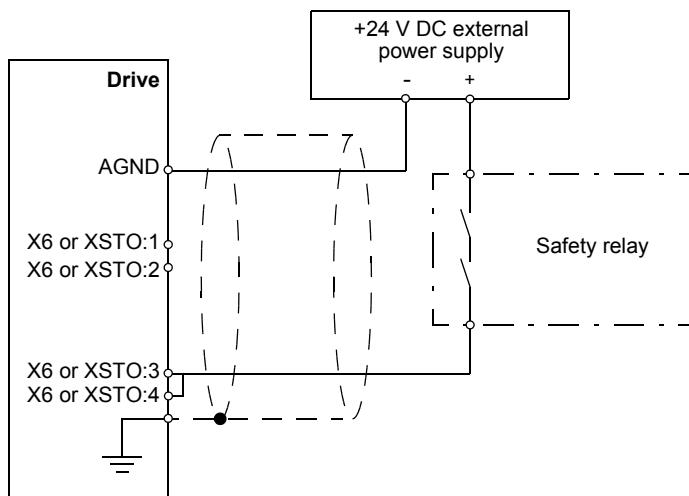
Single drive module with external power supply, single channel

Multiple drive modules with internal power supply

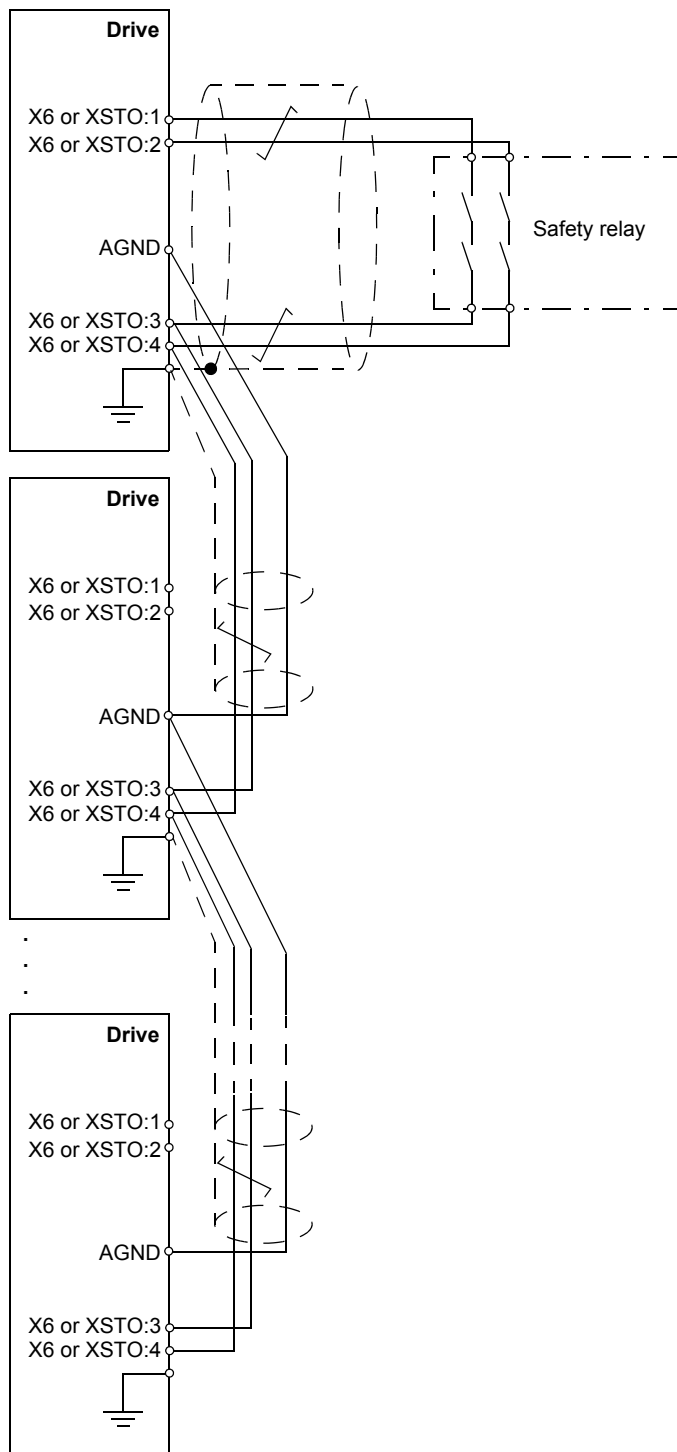

Multiple drive modules with external power supply

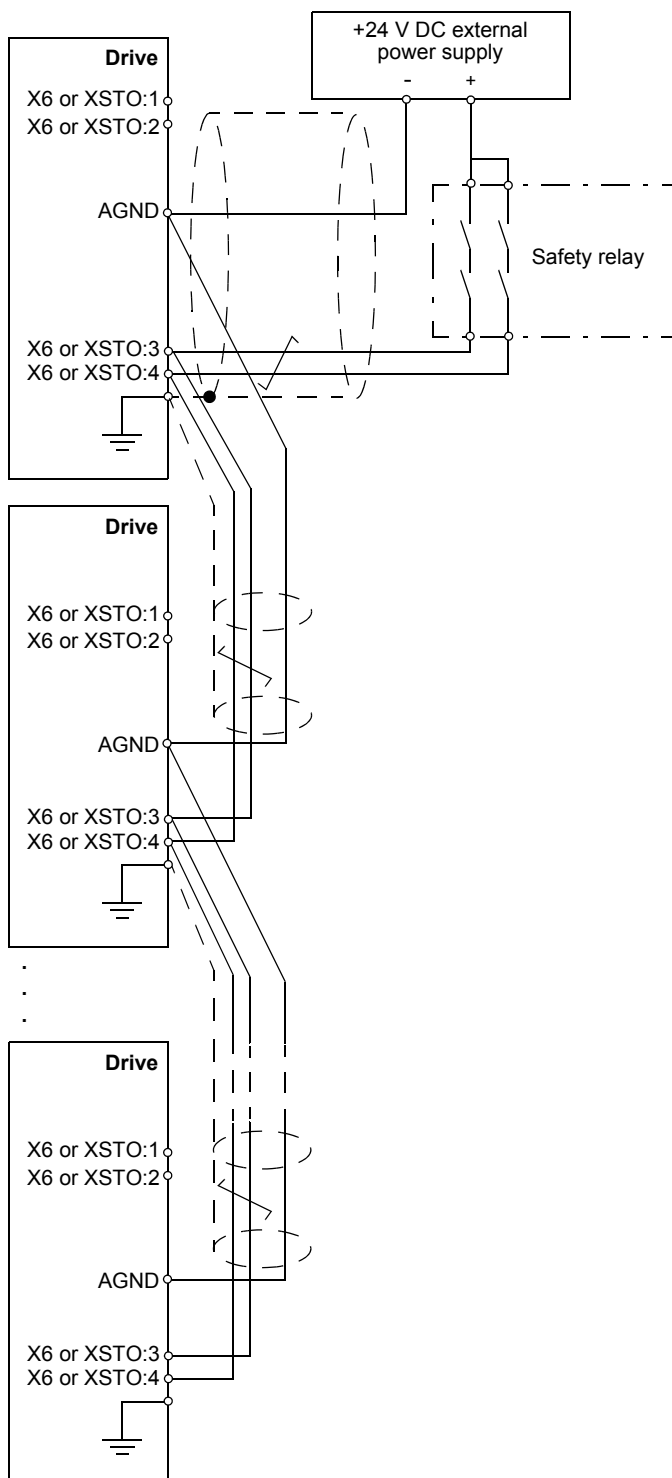

Multiple drive modules with internal power supply, single channel

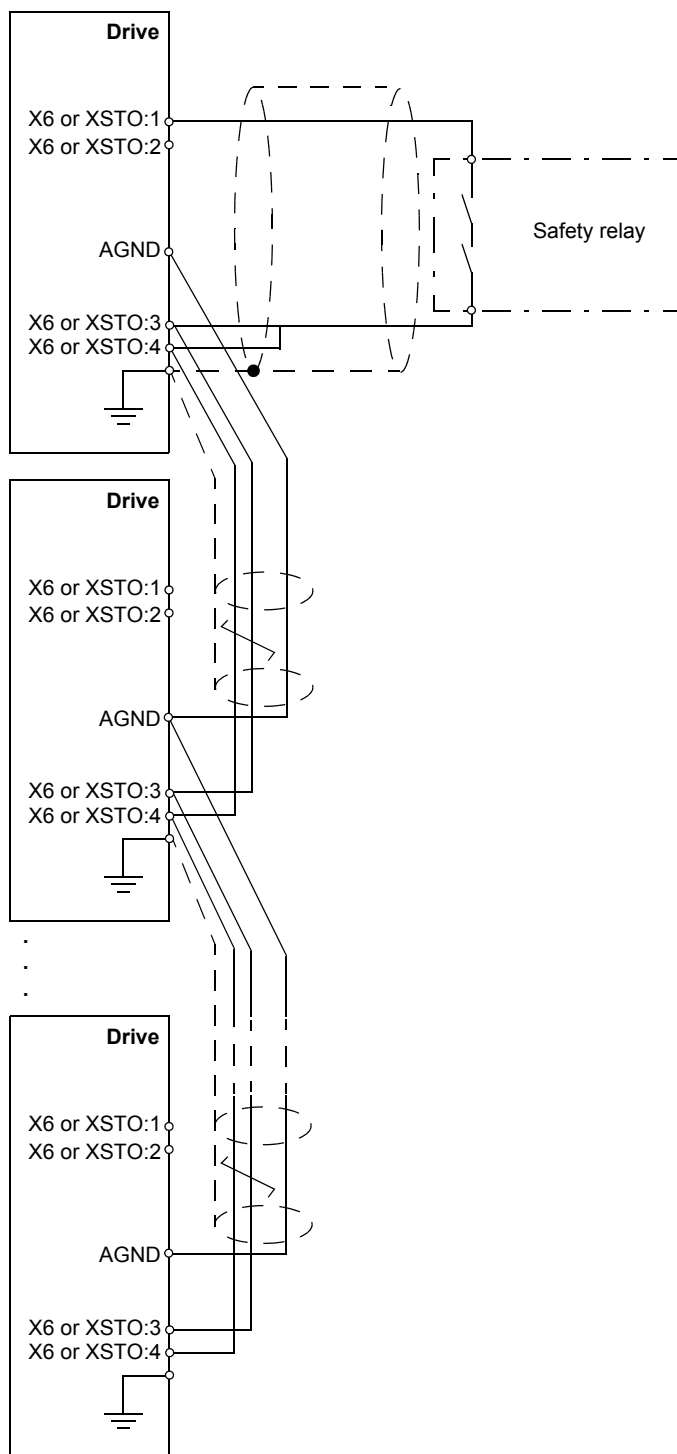

Multiple drive modules with external power supply, single channel

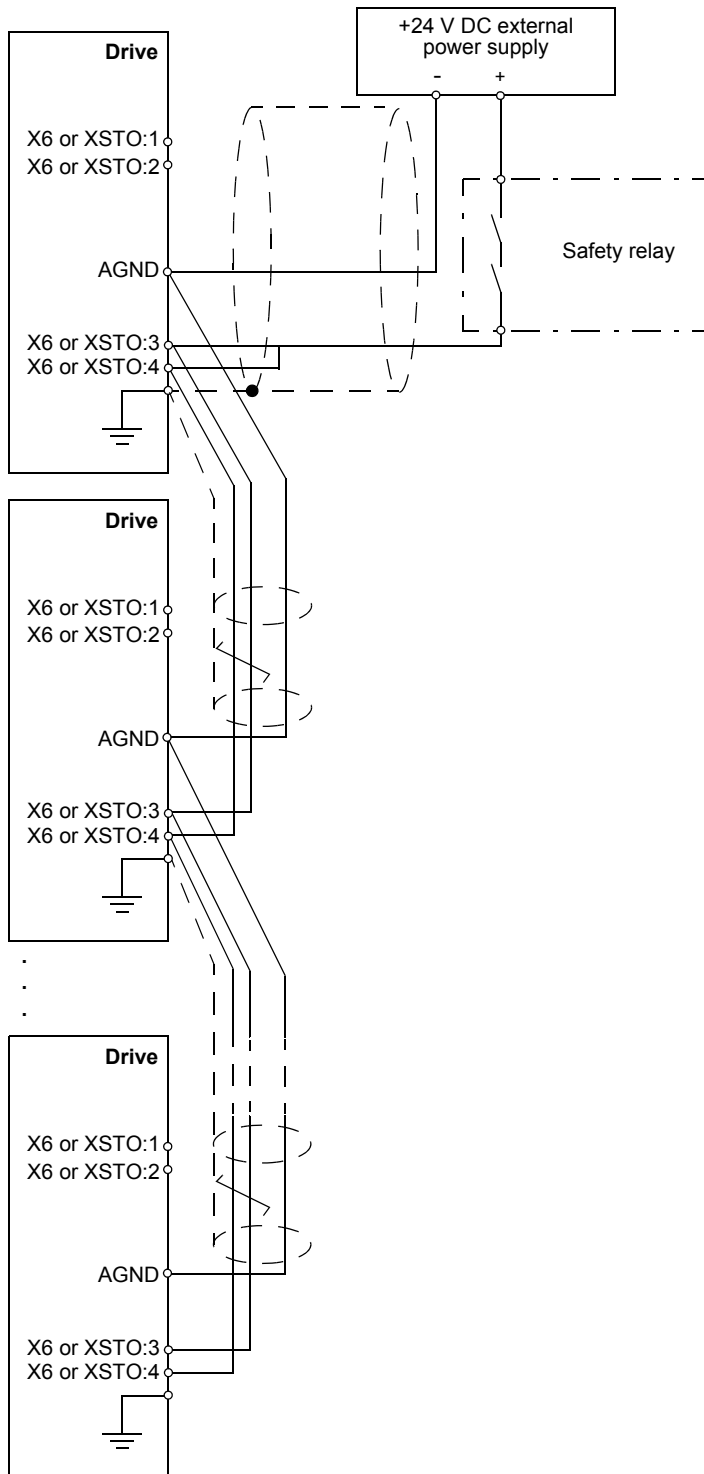

Start-up and validation

Validating the operation of a safety function

IEC 61508, EN IEC 62061 and EN ISO 13849 require that the final assembler of the machine validates the operation of the safety function with an acceptance test. The acceptance tests for the standard safety functions of the drive are described in the drive manuals. The tests for the optional safety functions are described in the appropriate option manuals.

The acceptance test must be performed:

- at initial start-up of the safety function
- after any changes related to the safety function (wiring, components, settings, etc.)
- after any maintenance work related to the safety function.

Authorized person

The acceptance test of the safety function must be carried out by an authorized person with expertise and knowledge of the safety function. The test must be documented and signed by the authorized person.

Acceptance test reports

Signed acceptance test reports must be stored in the logbook of the machine. The report shall include documentation of start-up activities and test results, references to failure reports and resolution of failures. Any new acceptance tests performed due to changes or maintenance shall be logged into the logbook.

Start-up checklist

	Action
<input type="checkbox"/>	Ensure that the drive can be run and stopped freely during the commissioning.
<input type="checkbox"/>	Stop the drive (if running), switch the input power off and isolate the drive from the power line by a disconnecter.
<input type="checkbox"/>	Check the STO circuit connections against the circuit diagram.
<input type="checkbox"/>	Check that the shield of the STO input cable is grounded to the drive frame (see the drive hardware manual).
<input type="checkbox"/>	Close the disconnecter and switch the power on.
<input type="checkbox"/>	Select the STO diagnostics mode by diagnostic parameter (see page 7) (change <i>Fault</i> to <i>Alarm</i> , <i>No</i> or <i>Only Alarm</i>).
<input type="checkbox"/>	Select the stop mode of the drive by parameter 11.03.
<input type="checkbox"/>	Test the operation of the STO function when the motor is stopped: <ul style="list-style-type: none"> • Give a stop command for the drive (if running) and wait until the motor shaft is at standstill. • Activate the STO circuit and give a start command for the drive. • Ensure that the motor stays at standstill and the drive operates as described in section Operation of the STO function and its diagnostics function on page 7. • Inactivate the STO circuit.
<input type="checkbox"/>	Restart the drive and check that the motor runs normally.
<input type="checkbox"/>	Test the operation of the STO function when the motor is running: <ul style="list-style-type: none"> • Start the drive and ensure the motor is running. • Activate the STO circuit. • Ensure that the motor stops and the drive trips. • Reset the fault and try to start the drive. • Ensure that the motor stays at standstill and the drive operates as described in section Operation of the STO function and its diagnostics function on page 7. • Inactivate the STO circuit.
<input type="checkbox"/>	Restart the drive and check that the motor runs normally.
<input type="checkbox"/>	Document and sign the acceptance test report which verifies that the safety function is safe and accepted to operation.

Maintenance, fault tracing and diagnostics

Maintenance

Include the STO operation test described in chapter [Start-up and validation](#) to the routine maintenance program of the machinery that the drive runs.

The STO function or STO input terminals do not need any maintenance. Maintain the drive according to the instructions given in the drive hardware manual.

Alarm messages generated by the drive

Alarm	Cause	What to do
SAFE TORQUE OFF (A-2003)	The Safe torque off function generates this indication when the function is activated.	Switch the STO function to standby by energizing the STO inputs. The alarm resets automatically. The indication can be prevented by changing the value of diagnostic parameter to <i>No</i> .

Fault messages generated by the drive

Fault	Cause	What to do
SAFE TORQUE OFF (F-0031)	Safe torque off related fault: - wrong parameter setting - faulty safety relay - loose wiring contact	Check the value of diagnostic parameter. If the value is <i>Fault</i> , every STO input switch off (one or both) causes a fault trip. Check the safety relay(s). Both contacts connected to the drive STO inputs must open or close simultaneously. Check STO relay wiring.
STO1 LOST (F-0021)	STO1 input (X6: pins 1,3 in ACSM1 or XSTO: pins 1,3 in ACS850 and ACQ810) is de-energized and STO2 input (X6: pins 2,4 in ACSM1 or XSTO: pins 2,4 in ACS850 and ACQ810) is energized simultaneously due to: - faulty STO relay - loose wiring contact.	Check the operation of the safety relay. Both safety relay paths must open or close within 200 ms. Check STO relay wiring.
STO2 LOST (F-0022)	STO1 input (X6: pins 1,3 in ACSM1 or XSTO: pins 1,3 in ACS850 and ACQ810) is energized and STO2 input (X6: pins 2,4 in ACSM1 or XSTO: pins 2,4 in ACS850 and ACQ810) is de-energized simultaneously due to: - faulty STO relay - loose wiring contact.	Check the operation of the safety relay. Both safety relay paths must open or close within 200 ms. Check STO relay wiring.

Technical data

STO components

STO safety relay type

General requirements	IEC 61508 and/or IEC 61511 and/or EN/ISO 13849-1		
Output requirements			
No. of current paths	2 independent paths (one for each STO path)		
Switching voltage capability	30 V DC per contact		
Switching current capability	100 mA per contact		
Maximum switching delay between contacts	200 ms		
Internal supply/multiple units			
Maximum length of total safety circuit between interconnected drives	10 m (30 ft)		
Equipotential connection of ground AGND's of all drives			
• Number of option modules in supplying drive	0	1	2...3
• Maximum number of drives in circuit	10	5	0
External supply/multiple units			
External power supply	24 V DC \pm 10%		
Current requirement	100 mA per connected drive		
Example 1	Simple SIL3 approved safety relay		
Type and manufacturer	PSR-SCP- 24UC/ESP4/2X1/1X2 by Phoenix Contacts		
Approvals	EN 954-1, cat 4; IEC 61508, SIL3		
Example 2	Programmable safety logic		
Type and manufacturer	PNOZ Multi M1p by Pilz		
Approvals	EN 954-1, cat 4; IEC 61508, SIL3; and ISO 13849-1, PL e		

STO cable

Type	2×2×0.75 m ² low voltage, single shielded, twisted pair cable
Maximum length	25 m between STO inputs and the operating contact
Example cable	Li YCY TP 2×2×0.75 mm ² shielded twisted pair cable by HELUKABEL or CEAM

Data related to safety standards

		IEC 61508					EN/ISO 13849					IEC 62061	IEC 61511
	SIL	PFH	HFT	SFF	Lifetime	PFD	PL	CCF	MTTF _D	DC*	Category	SILCL	SIL
ACSM1 drives													
A	3	1.77E-10 1/h (0.177 FIT)	1	98.1%	10 years	To be added	e	80 points	17101 years	99%	4	3	3
B	3	1.77E-10 1/h (0.177 FIT)	1	98.1%	10 years	To be added	e	80 points	17101 years	99%	4	3	3
C-D	3	1.77E-10 1/h (0.177 FIT)	1	98.1%	10 years	To be added	e	80 points	17101 years	99%	4	3	3
E	3	0.624E-09 1/h (0.624 FIT)	1	98.8%	10 years	To be added	e	80 points	15931 years	99%	4	3	3
ACS850 drives													
A	3	5.11E-10 1/h (0.511 FIT)	1	99.13%	10 years	7,74E-06	e	80 points	27779 years	99%	3	3	3
B	3	5.93E-10 1/h (0.593 FIT)	1	98.66%	10 years	1,13E-05	e	80 points	15243 years	99%	3	3	3
C-D	3	5.11E-10 1/h (0.511 FIT)	1	99.13%	10 years	7,74E-06	e	80 points	27779 years	99%	3	3	3
E0, E	3	5.63E-10 1/h (0.563 FIT)	1	98.64%	10 years	1,00E-05	e	80 points	23702 years	99%	3	3	3
G	3	1.21E-08 1/h (12.1 FIT)	1	95.72%	10 years	8,99E-05	e	80 points	2033 years	99%	3	3	3
ACQ810 drives													
A	3	5.11E-10 1/h (0.511 FIT)	1	99.13%	10 years	7,74E-06	e	80 points	27779 years	99%	3	3	3
B	3	5.93E-10 1/h (0.593 FIT)	1	98.66%	10 years	1,13E-05	e	80 points	15243 years	99%	3	3	3
C-D	3	5.11E-10 1/h (0.511 FIT)	1	99.13%	10 years	7,74E-06	e	80 points	27779 years	99%	3	3	3
E0, E	3	5.63E-10 1/h (0.563 FIT)	1	98.64%	10 years	1,00E-05	e	80 points	23702 years	99%	3	3	3
G	3	1.21E-08 1/h (12.1 FIT)	1	95.72%	10 years	8,99E-05	e	80 points	2033 years	99%	3	3	3

* According to the categorization defined in EN/ISO 13849-1.

Abbreviations

Abbreviation	Reference	Description
CCF	EN/ISO 13849-1	Common Cause Failure (%)
DC	EN/ISO 13849-1	Diagnostic Coverage
FIT	IEC 61508	Failure In Time: 1E-9 hours
HFT	IEC 61508	Hardware Fault Tolerance
MTTF _D	EN/ISO 13849-1	Mean Time To dangerous Failure: (The total number of life units) / (the number of dangerous, undetected failures) during a particular measurement interval under stated conditions
PFD	IEC 61508	Probability of Failure on Demand
PFHd	IEC 61508	Probability of Dangerous Failures per Hour
PL	EN/ISO 13849-1	Performance Level: Corresponds SIL, Levels a-e
SFF	IEC 61508	Safe Failure Fraction (%)
SIL	IEC 61508	Safety Integrity Level
STO	EN 61800-5-2	Safe torque off

TÜV certificate – ACSM1



Certificate

TÜV NORD SysTec GmbH & Co. KG hereby certifies

ABB Oy
Hiomotie 13
FI-00381 Helsinki
Finland

for the realisation of the function "Safe Torque Off - STO"
in the ABB high performance machinery drives

Type ACSM1 frame A-E

the compliance with the requirements listed in the following standards

- IEC 61508; Part 1:1998 + Corrigendum 1999
- IEC 61508; Part 2:2000; SIL 3 capability for STO function
- EN 954-1:1997; Category 4
- IEC 62061:2005; SILCL 3
- ISO 13849-1:2006; PL "e"

based on reports No. SAS-103/2006C and SAS-204/2008TB in the valid version.
This certificate entitles the holder to use the mark:



ACSM1
frame A-E
with STO function

EN 954-1:1997
Category 4;
IEC 61508-1:1998 and
Corrigendum 1999;
IEC 61508-2:2000;
SIL3 capability
IEC 62061:2005
SILCL3 capability
EN ISO 13849-1:2006
PL "e"

SAS0012/07
Voluntary Certification

Certification No.: SAS0012/07, Vers. 2.0
Reference: G.SCC.DL.03.004.04.SLA
Valid to: 2012-05-25

Augsburg, 2007-05-25

 Dr. Immanuel Höfer

TÜV NORD SysTec GmbH & Co. KG
Branch South
Halderstr. 27 - 86150 Augsburg
Germany

07

TÜV certificate – ACS850



Certificate

No. SAS-0203/08, Ver. 2

TÜV NORD SysTec GmbH & Co. KG hereby certifies

ABB Oy
Hiomotie 13
FI-00381 Helsinki
Finland

that the implementation of the safety function “Safe Torque Off“ (STO) in the ABB high performance machinery drive

Type ACS850 Frame A, B, C, D, E, E0, G

is capable for safety related applications up to SIL 3, SILcl 3 and PL e and meets the requirements listed in the following standards

- IEC 61508 part 1:1998; part 2:2000; capable up to SIL 3
- IEC 61800-5-2:2007; capable up to SIL 3
- ISO 13849-1:2008; capable up to PL e (category 3)
- IEC 62061:2005; capable up to SIL_{CL}3
- IEC 61511: 2004; capable up to SIL3

The certification is based on the report No. SAS-0203/08TB-1 in the valid version
This certificate entitles the holder to use the pictured Safety Approved mark

Expiry date: 2015-05-19
Reference No.: G.SCC.DL.03.004.05.SLA

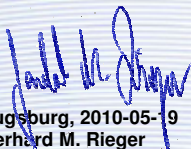
Augsburg, 2010-05-19
Gerhard M. Rieger
Branch Manager



TÜV NORD SysTec GmbH & Co. KG, Branch South, Halderstr. 27, 86150 Augsburg, Germany

TÜV certificate – ACQ810



Certificate

TÜV NORD SysTec GmbH & Co. KG hereby certifies

ABB Oy
Hiomotie 13
FI-00381 Helsinki
Finland

that the implementation of the safety function “Safe Torque Off“ (STO) in the ABB high performance machinery drives

Type ACQ810 Frame A, B, C, D, E, E0, G

meets the requirements listed in the following standards

- IEC 61508 part 1:1998; part 2:2000; SIL 3
- IEC 61800-5-2:2007; SIL 3
- ISO 13849-1:2008; PL e (category 3)
- IEC 62061:2005; SIL_{CL3}

based on report no. SLA-0016/10TB-1 in the valid version.

This certificate entitles the holder to use the mark



SLA-0016/10
Voluntary Certification

Expiry date: 2015-02-01
Certification No.: SLA-0016/10
Reference No: G.SCC.DL.06.045.02.SLA

Augsburg, 2010-02-01

TÜV NORD SysTec GmbH & Co. KG
Branch South
Halderstraße 27
86150 Augsburg

Immanuel Höfer
Dr. Immanuel Höfer

10

Further information

Product and service inquiries

Address any inquiries about the product to your local ABB representative, quoting the type designation and serial number of the unit in question. A listing of ABB sales, support and service contacts can be found by navigating to www.abb.com/drives and selecting *Sales, Support and Service network*.

Product training

For information on ABB product training, navigate to www.abb.com/drives and select *Training courses*.

Providing feedback on ABB Drives manuals

Your comments on our manuals are welcome. Go to www.abb.com/drives and select *Document Library – Manuals feedback form (LV AC drives)*.

Document library on the Internet

You can find manuals and other product documents in PDF format on the Internet. Go to www.abb.com/drives and select *Document Library*. You can browse the library or enter selection criteria, for example a document code, in the search field.



3AFE68929814 Rev F / EN
EFFECTIVE: 2011-02-18

ABB Oy

Drives
P.O. Box 184
FI-00381 HELSINKI
FINLAND
Telephone +358 10 22 11
Fax +358 10 22 22681
Internet www.abb.com/drives

ABB Inc.

Automation Technologies
Drives & Motors
16250 West Glendale Drive
New Berlin, WI 53151
USA
Telephone 262 785-3200
1-800-HELP-365
Fax 262 780-5135
Internet www.abb.com/drives

ABB Beijing Drive Systems Co. Ltd.

No. 1, Block D, A-10 Jiuxianqiao Beilu
Chaoyang District
Beijing, P.R. China, 100015
Telephone +86 10 5821 7788
Fax +86 10 5821 7618
Internet www.abb.com/drives