

Safety Relays

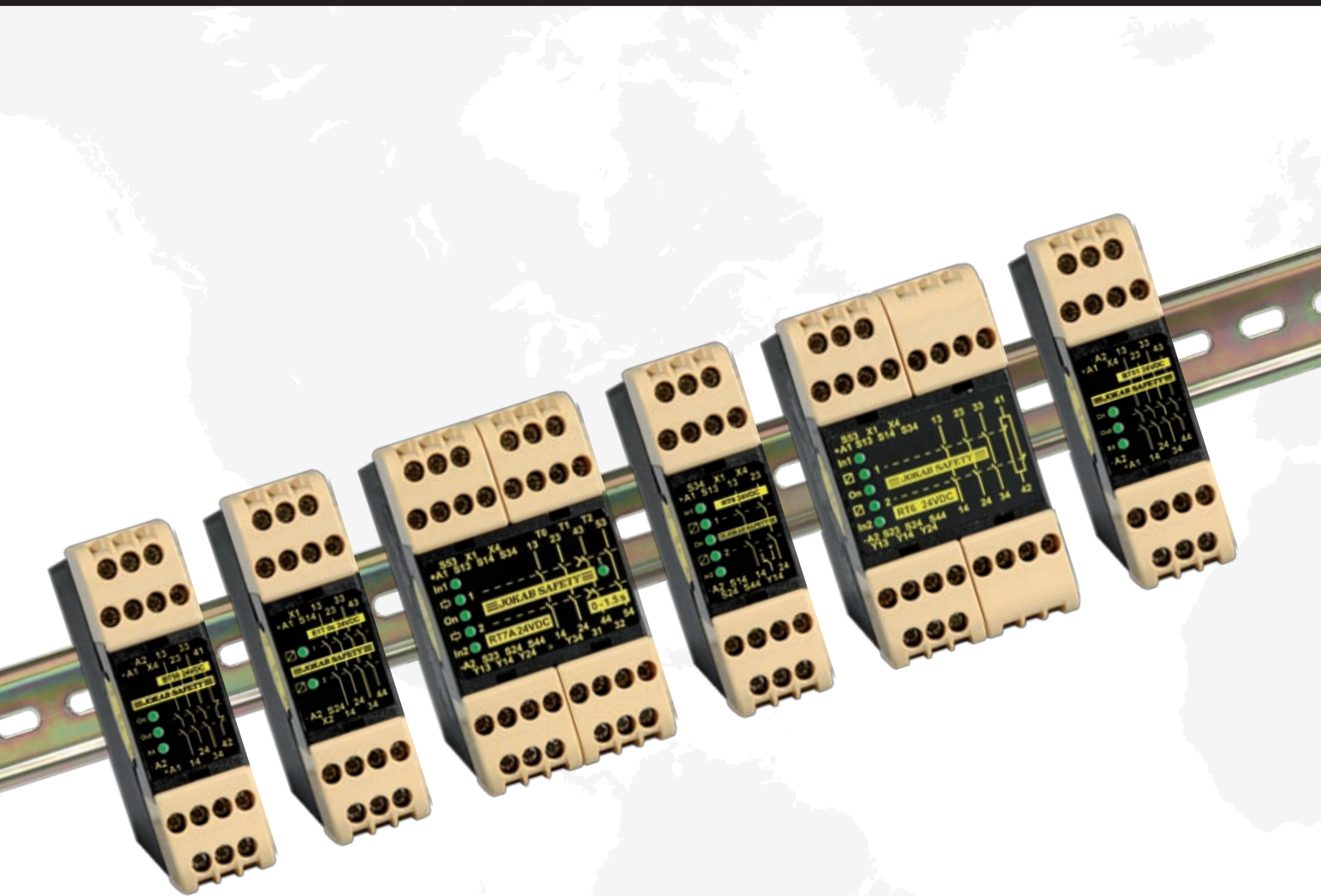

Contents	Page
<i>Why should you use Safety relays?</i>	6:2
<i>The smallest and most flexible Safety relays on the market</i>	6:3
<i>Safety relay summary</i>	6:4
Safety relay - RT - series	
• RT6	6:6
• RT7	6:10
• RT9	6:14
• JSBRT11	6:18
Safety relay - JSB - series	
• JSBR4	6:20
• JSBT4	6:22
• BT50(T)	6:24
• BT51(T)	6:26
• JSBT5(T)	6:28
Safety timers	
• JSHT1A/B	6:30
• JSHT2A/B/C	6:32
Expansion relays	
• E1T	6:34
• JSR1T	6:36
• JSR2A	6:38
• JSR3T	6:40
Connection examples	6:42

Descriptions and examples in this book show how the products work and can be used. This does not mean that they can meet the requirements for all types of machines and processes. The purchaser/user is responsible for ensuring that the product is installed and used in accordance with the applicable regulations and standards. We reserve the right to make changes in products and product sheets without previous notice. For the latest updates, refer to www.jokabsafety.com. 2011.

Why should you use safety relays?

- to meet existing safety standards!

"A fault in the control circuit logic, or failure of or damage to the control circuit must not lead to dangerous situations". This is the requirement in the EU's Machinery Directive 98/37/EC under the heading 1.2.7. "Failure of the control circuit". The directive implies that no person should be put at risk if for example, a relay sticks or if a transistor or two electrical conductors short-circuit.

A safety relay will fulfill these requirements. A safety relay

has, for example, inputs that are checked for short-circuits and dual redundant circuits that are checked at each operation. This can be compared to the dual brake circuits in a car. If one of the circuits is faulty the other will stop the car. In a safety relay there is an additional function which only allows a machine to start if both circuits are ok.

The standard for safety related parts of the control system describes various safety categories depending on the level of risk and application. One single universal relay with selectable safety categories solves this.

- to supervise safety devices!



Light beams

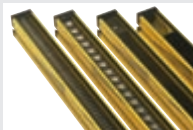

Light curtains/
Light grids



Three position
devices



Safety
interlock
switches

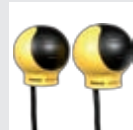

Two-hand
devices



Emergency
stop



Safety strips
& Bumpers

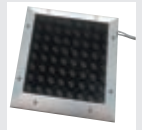

Safety mats

- for safe stops and reliable restarts!

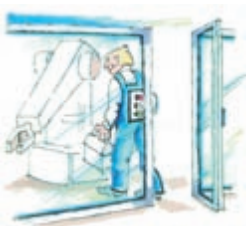

Dual stop signals when the gate is opened.

Entering or putting a hand or limb into a hazardous area must cause all machinery that can cause personal injury to stop safely. Many serious accidents occur when machinery is believed to have stopped but is in fact only pausing in its program sequence. The safety relay monitors the gate interlock switch and cables and gives dual stop signals.



Supervised reset when there can be a person within the risk area.

To make sure that nobody is within the restricted area when activating the reset button. A supervised reset button must be pressed and released before a reset can occur. Many serious accidents have been caused by an unintentional and unsupervised reset.



Timed reset when you cannot see the entire risk area.

Sometimes a double reset function is necessary to make sure that no one is left behind in the risk area. First, after ensuring no other person is inside the hazardous area, the pre-reset button must be activated, followed by the reset button outside the risk area within an acceptable time period e.g 10 seconds. A safety timer and a safety relay can provide this function.



Automatic reset for small hatches.

Where body entry is not possible through a hatch, the safety circuit can be automatically reset.

The safety relays are reset immediately when the hatch interlock switch contacts are closed.

The most flexible safety relays on the market!

We have the most flexible safety relays on the market. Our first universal relay was developed in 1988.

Nowadays, the flexibility is even greater and size has been reduced by 85 %.

A universal relay is a safety relay with various input options for various safety devices and risk levels.

Internally, the safety relay is of the highest safety level (PL e according to EN ISO 13849-1). A machine supplier can therefore, with one single safety relay, select the input configuration that best suits their customers' safety requirements. In addition, our safety relays have detachable connector blocks for ease of replacement and testing. As our universal relays incorporate all input options, they are

compatible with all our previous safety relays as well as with other manufacturers' products.

Is a universal relay expensive? No, our latest patented construction is extremely simple and the number of major components is less compared to our previous universal relays. This means that the safety relays are even more reliable than before.

We also have a great deal of experience from safety solutions in our own system developments. It would be our pleasure to share these experiences with you! Please see the complete safety solutions in the section "Connection examples". Please do not hesitate to contact us if you should require any other safety solutions.

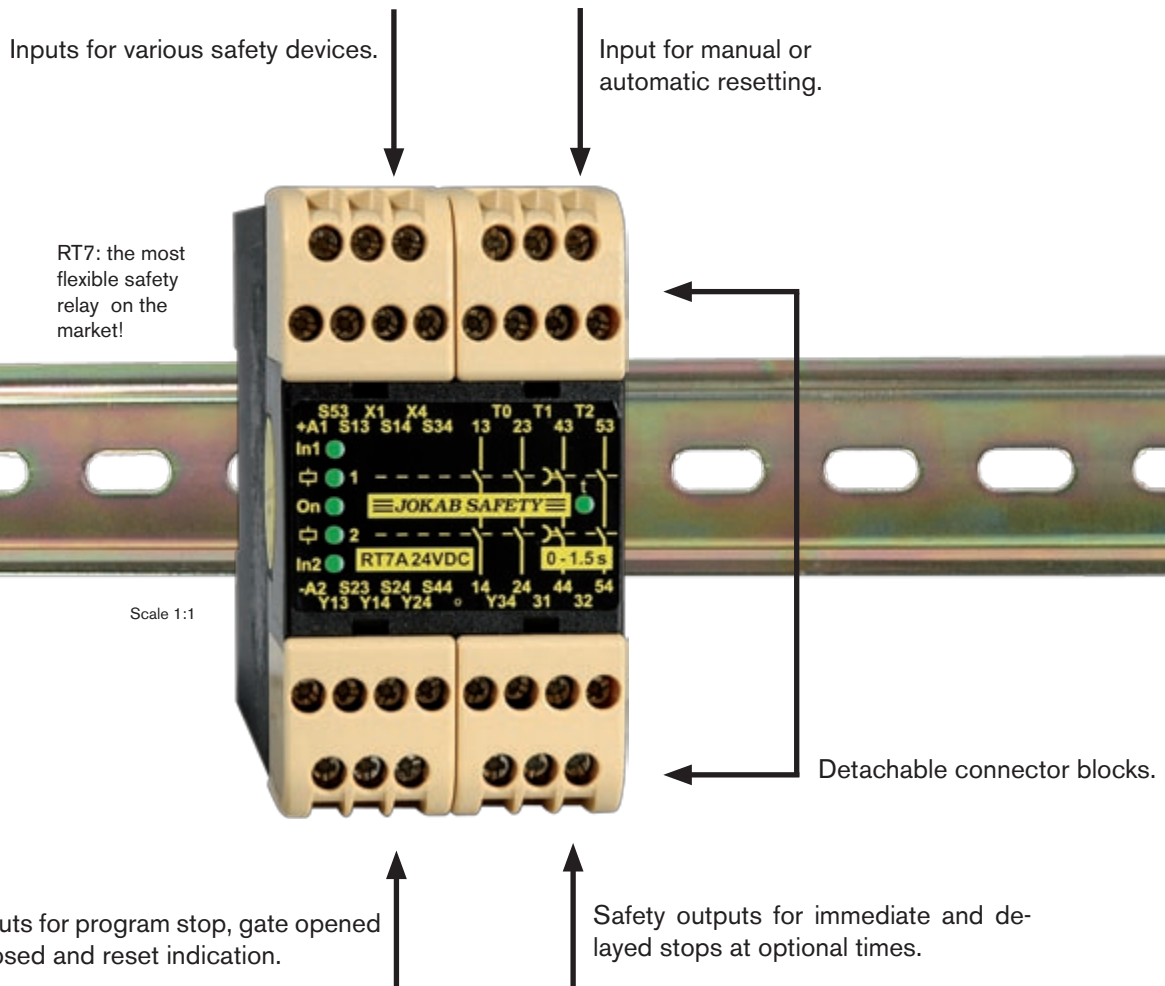

Some of the advantages with ABB/Jokab Safety's safety relays:

- Universal relays
- Excellent reliability
- Approved in Europe, USA, Canada
- Supervised reset
- Time reset
- Small and compact
- Detachable connector blocks
- Low power consumption
- Permits the use of long emergency stop cables
- EX compatibility
- Functions set by external hardwired links
- LED indication for inputs and outputs
- Powerful switching capacity

summary SAFETY RELAYS

- Which safety relay should you choose?

First of all, we would recommend the selection of one of our latest universal relays in the RT-series. These are both practical and cost effective.

To facilitate the choice of safety relay or combinations of safety relays, please see:

- the table below dividing the safety relays into application fields
- the table on the opposite page showing possible input and output options
- the relevant data sheet giving comprehensive information about each specific safety relay
- the circuit diagram for various applications in the section "Connection examples".

Note: All earlier types of relays that can now be replaced by those in this manual are still kept as stock items and can be supplied upon request.

Application fields

	Safety relays					Safety-timers		Expansion relays						
	RT6	RT7	RT9	JSBRT11	JSBR4	JSBT4	JSBT51, BT50T, BT51T	JSBT5, BT50, BT51	JSH1A/B	JSH2A/B/C	E1T	JSRTT	JSR2A	JSR3T
Interlocking switch/Gate/Hatch	•	•	•	•	•	•	•	•						
Light curtains	•	•	•	•										
Light beams	•	•	•	•										
Safety mats	•	•	•		•	•								
Contact strips	•	•	•		•	•								
Two-hand control device					•									
Emergency stop	•	•	•	•	•	•	•	•						
Hold to run/enabling device	•	•	•	•	•	•				•				
Foot control device	•	•	•	•	•	•				•				
Area supervision	•	•	•	•	•	•								
Time resetting									•					
Time bypassing									•	•				
Inching										•				
Output expansion	•	•	•	•		•	•	•			•	•	•	
Delayed output		•					•				•	•		•

Input alternatives (see also technical data on the next page)

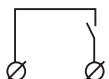

Single-channel, 1 NO from +24 V Category 1, up to PL c
The input must be closed before the outputs can be activated. A stop signal is given when the input is opened.

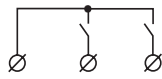

Two-channel, 2 NO from +24 V Category 3, up to PL d
Both the inputs must be closed before the outputs can be activated. A stop signal is given if one or both of the inputs are opened. Both the inputs must be opened and reclosed before the outputs can be reactivated. A short-circuit between the inputs is not monitored by the safety relay. Category 4 can only be achieved if a safety device with short circuit monitored outputs is connected.

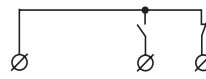

Two-channel, 1 NO & 1 NC from +24V Category 4, up to PL e
One input must be closed and one must be opened before the outputs can be activated. A stop signal is given if one or both of the inputs change position or if the inputs short-circuit. Both inputs must be put into their initial position before the outputs can be reactivated.

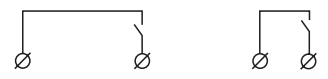

Two-channel, 1 NO from 0 V & Category 4, up to PL e
Both the inputs must be closed before the outputs can be activated. A stop signal is given if one or both of the inputs are opened. Both the inputs must be opened and reclosed before the outputs can be reactivated. A Stop signal is given if there is a short-circuit between the inputs.

Technical data

	Safety relays										Safety-timers		Expansion relays				
	RT6	RT7	RT9	JSBRT11	JSBR4	JSBT4	JSBT5T	BT50T	BT51T	BT50 (JSBT5)	BT51	JSHT1A/B	JSHT2A/B/C	E1T	JSR1T	JSR2A	JSR3T
Safety category	1-4	1-4	1-4	1-4	4	4	1-4°	1-4°	1-4°	1-4°	1-4°	1-4	1-4	1-4	1-4	1-4	1-4
Safety input																	
Single-channel, 1 NO from +24 V	•	•	•	•			•	•	•	•	•	•	•	•	•	•	•
Two-channel, 2 NO from +24 V	•	•	•	•													
Two-channel, 1 NO & 1 NC from +24 V	•	•	•	•													
Two-channel, 1 NO from 0 V & 1 NO from + 24 V	•	•	•	•	•	•					•	•	•	•	•	•	•
Contact strips/Safety mats	•	•	•		•	•											
Reset & test input																	
Monitored manual	•	•	•	•	•												
Automatic/Unmonitored manual	•	•	•	•		•	•	•	•	•	•						
Testing of contactors, relays, valves, etc.	•	•	•	•	•	•	•	•	•	•	•	•	•				
Output																	
NO	3	2	2	7	3	3				3	4			4*	4*	4	
NO delayed		2					3 [†]	3	4					4*	4*		2 [‡]
NO impulse outputs												2 [‡]	2 [‡]				
NC	1	1		2	1	1				1					1*	1	
NC delayed							1 [†]	1							1*		
Info. output	2	3	1					1	1								
Switching capacity (resistive load)																	
6A/250VAC/1500VA/150W	4	3	2	9	4	4	4	4 [‡]	4 [‡]	4	4			4	5		
4A/250VAC/1000VA/100W												2 [‡]	2 [‡]				2 [‡]
6A/250VAC/1380VA/138W		2 [‡]															
10A/250VAC/1840VA/192W																	5
Width (mm)	45	45	22,5	100	45	45	22,5	22,5	22,5	22,5	22,5	45	45	22,5	45	45	22,5
Supply voltage																	
12VDC							•										
24VDC	•	•	•	•	•	•	•	•	•	•	•	•	•	•	•	•	•
24VAC	•	•		•	•	•	•					•	•			•	•
48VAC	•	•		•	•	•						•	•			•	
115VAC	•	•		•	•	•						•	•			•	
230VAC	•	•		•	•	•						•	•			•	
* Indicates the possibility of selecting delayed outputs ‡ Indicates one relay contact per output (other relays having two contacts per output)																	
† delayed ° Category 4 depending on connection (When used as expansion relay with Pluto Safety PLC, then Category 4) † fixed 0.5 s delay																	

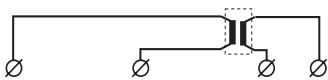

Contact strips/Safety mats
Category 3, up to PL d

For an unpressurised mat/strip, both the relay inputs must be closed for the outputs to be activated. In the case of an activated mat/strip and short-circuit input channels, the relay will be de-energized. Current limitation prevents the safety relay from being overloaded when the channels short-circuit.

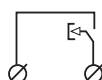

Monitored manual reset

A monitored reset means that the safety relay will not be reset if the reset button gets jammed when pressed in or if the input short-circuits. In order for the resetting to be complete, the input must be closed and opened before the outputs can close.

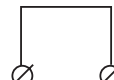

Automatic/unmonitored manual reset

Automatic reset means that the outputs are closed immediately when both the input conditions are satisfied and the test input is closed.

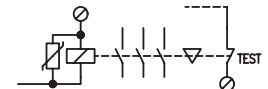

Testing of contactors, relays & valves

Can be carried out with both automatic and manual reset.

Safety relay

RT6

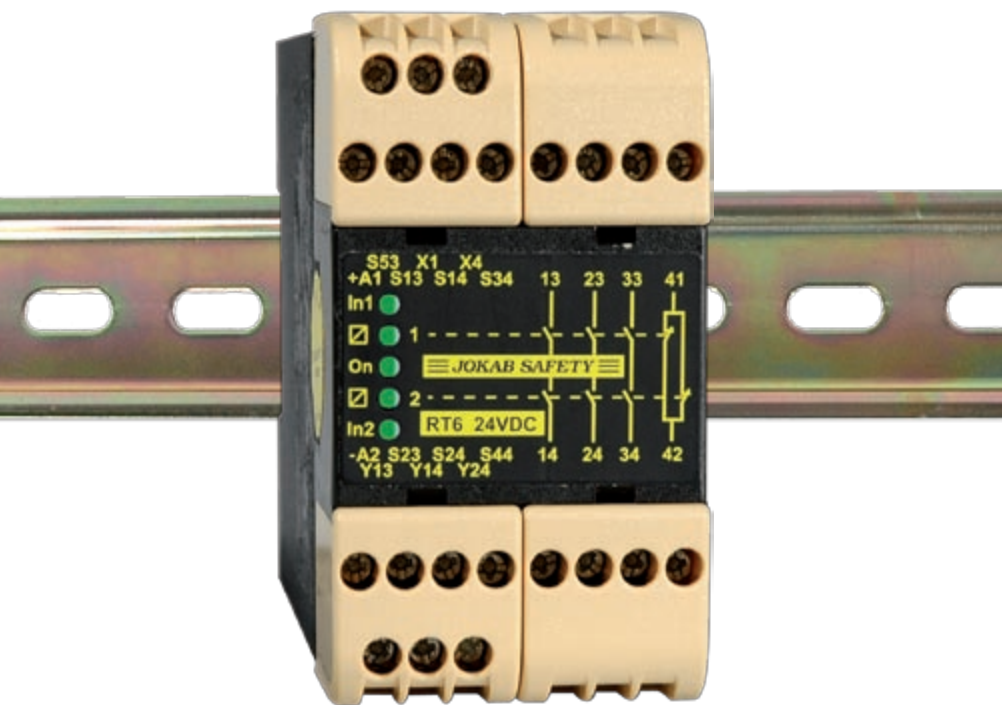

Would you like a single safety relay for all your safety applications?

Then choose the RT6 universal relay to supervise both your safety devices and the internal safety of your machinery. In addition you can select the safety level required for each installation. All this is possible because the RT6 has the most versatile input option arrangement available on the market. Many other relays can therefore be replaced by the RT6.

The relay also comes with other options such as manual or automatic reset. Manual supervised reset can be used for gates and other safety devices that can be bypassed. Automatic reset can be used for small hatches, if deemed acceptable from risk assessment.

The RT6 also has information outputs that follow the inputs and outputs of the relay. These outputs will for example indicate if a gate is open or closed and if the safety relay needs to be reset.

The RT6 is designed with a minimum amount of components thus keeping both production costs and component acquisitions to a minimum.

Choose the RT6 to simplify your safety circuits and reduce your costs.

Approvals:



Safety relay for:

- Emergency stops
- Light curtains
- Three position devices
- Interlocked gates/hatches
- Magnetic switches
- Light beams
- Safety mats
- Contact strips
- Foot operated switches

Features:

- Five input options
- Single or dual channel input
- Manual supervised or automatic reset
- Test input for supervision of external contactors
- Width 45 mm
- LED indication of supply, inputs, outputs, short-circuit and low voltage level.
- 3 NO/1 NC relay outputs
- Two voltage free transistor information outputs
- Supply 24 VDC, 24, 48, 115 or 230 VAC
- Quick release connector blocks

Technical information - RT6

Inputs

The inputs from the safety devices must be connected according to one of the following options in order to fulfill the expected safety level and to avoid unsafe situations.

1. Single channel, 1 NO contact from +24 V DC, category 1, up to PL c
2. Dual channel, 2 NO contacts from +24 V DC, category 3, up to PL d
3. Dual channel 1 NO, 1 NC contact from +24 V DC, category 4, up to PL e
4. Dual channel, 1 NO contact from 0V and 1 NO contact from +24 V DC, category 4, up to PL e
5. Safety mats/contact strips 1 'contact' from 0V and 1 'contact' from +24 V DC, category 3, up to PL d

When the input/inputs are activated and the test/supervised reset is complete, relays 1 and 2 are energized. Simultaneous activation is not required where there are dual channels. The two relays are de-energized when the input/inputs are de-activated in accordance with the input option chosen or in case of a power failure. Relays 1 and 2 must both be de-energized before the outputs can be activated again.

Transistor output status information

The RT6 has two voltage free transistor outputs that can be connected to a PLC, computer or other monitoring device. These outputs give the input and output status of the relay.

Reset and testing

The RT6 has two reset options; manual and automatic. The manual supervised reset is used when the RT6 is monitoring safety devices that can be bypassed, i.e. to ensure that the outputs of the safety relay do not close just because a gate is closed. The automatic reset should only be used if deemed an acceptable risk.

In addition, the RT6 can also test (supervise) whether, for example, contactors and valves etc are de-energized/de-activated before a restart is allowed.

Indication of low voltage

The 'On' LED will flash if the relay supply voltage falls below an acceptable level. This indication will also be given if a monitored safety mat/contact strip is actuated. See connection option 5.

Safety level

The RT6 has internal dual and supervised safety functions. A short-circuit, internal faulty component or external interference will not present a risk to options with the highest safety level. A manual reset requires that the reset input is closed and opened before the safety relay outputs are activated. A short-circuit or a faulty reset button is consequently supervised.

When the RT6 is configured for dual channel input, both the inputs are supervised for correct sequence operation before the unit can be reset.

The input options 3 and 4 have the highest safety levels as all short-circuits and power failures are supervised. This in combination with internal current limitation makes the relay ideal for supervision of safety mats and contact strips.

Regulations and standards

The RT6 is designed and approved in accordance with appropriate directives and standards. See technical data.

Connection examples

For examples of how our safety relays can solve various safety problems, see the section "Connection examples".

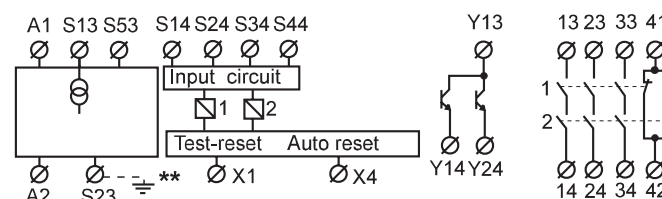

**Only for AC supply

Connection of supply - RT6

DC supply

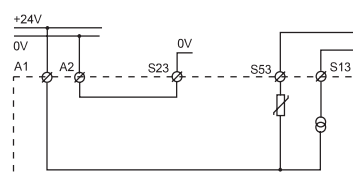

The RT6 DC option should be supplied with +24 V on A1 and 0 V on A2.

AC supply

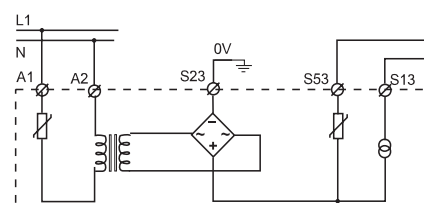

The RT6 AC option should be supplied with the appropriate supply voltage via connections A1 and A2.

The S23/PE must be connected to protective earth.

DC-supply of AC-units

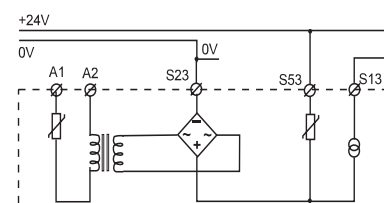

All AC-units can also be supplied by +24 VDC to S53 (0VDC to S23).

NOTE!

With both DC and AC modules, if cable shielding is used this must be connected to an earth rail or an equivalent earth point.

Connection of safety devices - RT6

1. SINGLE CHANNEL, 1 NO from +24V



The input (contact to S14) must be closed before the outputs can be activated. When the input contact is opened the relay safety output contacts open.

2. DUAL CHANNEL, 2 NO from +24V

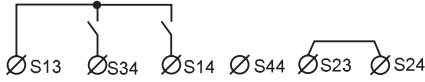

Both input contacts (S14 and S34) must be closed before the relay outputs can be activated. The safety relay contacts will open if one or both of the input contacts are opened. Both the input contacts must be opened and reclosed before the relay can be reset. A short-circuit between inputs S14 and S34 can only be supervised if the device connected to the inputs has short-circuit supervised outputs, e.g. JOKAB Focus light curtains.

3. DUAL CHANNEL, 1 NO, 1 NC from +24V

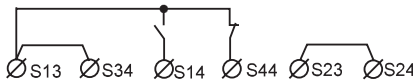

One input contact must be closed (S14) and one opened (S44) before the relay outputs can be activated. The safety relay contacts will open if one or both of the inputs change state or in case of a short-circuit between S14 and S44. Both inputs must return to their initial positions before the relay outputs can be reactivated.

4. DUAL CHANNEL, 1 NO from +24V, 1 NO to 0V

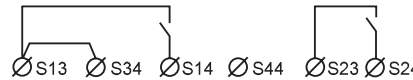

Relay functions as for option 2, but a short-circuit, in this case between inputs S14 and S24, is supervised (safety outputs are opened).

5. Safety mat/Contact strip

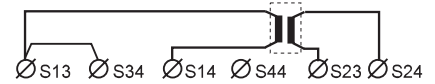

Both 'contact' inputs from a inactivated safety mat/contact strip must be made in order to allow the RT6 relay outputs to be activated. When the safety mat/contact strip is activated or a short-circuit is detected across S14-S23, the relay will de-energize (safety outputs open) and the 'ON' LED will flash. As output S13 has an internal current limit of 70 mA, the RT6 will not be overloaded when the mat/contact strip is activated or a short-circuit is detected.

Reset connections - RT6

Manual supervised reset

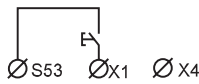

The manual supervised reset contact connected to input X1 must be closed and opened in order to activate the relay outputs.

Automatic reset

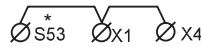

*connected to S13 for safety mat/contact strip

Automatic reset is selected when S53, X1 and X4 are linked. The relay outputs are then activated at the same time as the inputs.

Testing external contactor status

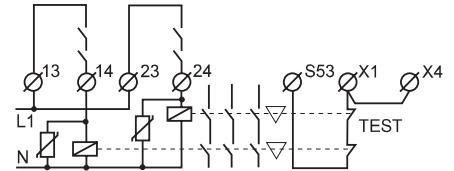

Contactors, relays and valves can be supervised by connecting 'test' contacts between S53 and X1. Both manual supervised and automatic reset can be used.

Output connections - RT6

Relay outputs

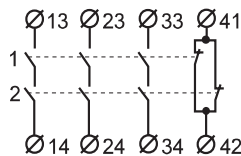

The RT6 has three (3 NO) safety outputs and 1 NC information output.

In order to protect the output contacts it is recommended that loads (inductive) are suppressed by fitting correctly chosen VDR's, diodes etc.

Diodes are the best arc suppressors, but will increase the switch off time of the load.

Transistor outputs

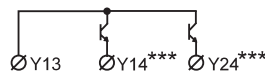

The RT6 has two(2) voltage free transistor outputs for information.

The transistor outputs are supplied with voltage to Y13, either from S53 (+24V) or an external 5-30 VDC supply. Y14 and Y24 follow the relay inputs and outputs as follows:

- Y14 becomes conductive when the relay input conditions are fulfilled.
- Y24 becomes conductive when both the output relays are activated.

***NOTE

These outputs are only for information purposes and must not be connected to the safety circuits of the machinery.

Technical data - RT6	
Manufacturer	ABB AB/Jokab Safety, Sweden
Article number/Ordering data	RT6 24DC 2TLJ010026R0000 RT6 24 AC 2TLJ010026R0200 RT6 115 AC 2TLJ010026R0400 RT6 230 AC 2TLJ010026R0500
Colour	Black and beige
Weight	335 g (24 VDC) 485 g (24-230 VAC)
Supply	Voltage (A1-A2) 24 VDC +15/-20%, 24/48/115/230 VAC, +15/-10%, 50-60 Hz
Power consumption	DC supply, nominal voltage 2,3 W AC supply, nominal voltage 5,2 VA
Connection S13 Short-circuit protected voltage output, 70 mA ± 10% current limitation. Is used for the inputs S14, S34 and S44.	
Connection S53 Short-circuit protected voltage output, internal automatic fuse 270 mA. Is used for the reset and autoreset inputs X1 and X4	
Connection S23 0V connection for input S24	
Safety inputs	
S14 (+) input	20 mA
S24 (0V) input	20 mA
S34 (+) input	20 mA
S44 (+) input	30 mA
Reset input X1	
Supply for reset input	+ 24VDC
Reset current	300 mA current pulse at contact, then 30 mA
Minimum contact closure time for reset	100 ms
Maximum external connection cable resistance at nominal voltage for	
S14, S24, S34	300 Ohm
S44, X1	150 Ohm
Response time	
At Power on DC/AC	<90ms/<220ms
When activating (input-output)	<20 ms
When deactivating (input-output)	<20 ms
At Power Loss	<150 ms
Relay outputs	
NO	3
NC	1
Maximum switching capacity	
Resistive load AC	6A/250 VAC/1500 VA
Inductive load AC	AC15 240VAC 2A
Resistive load DC	6A/24 VDC/150 W
Inductive load DC	DC13 24VDC 1A
Maximum total switching capacity	
Resistive load	12A distributed on all contacts
Minimum load	10mA/10 V (if load on contact has not exceeded 100 mA)
Contact material	Ag+Au flash
Fuses Output (External)	5A gL/gG
Conditional short-circuit current (1 kA)	6A gG
Mechanical life	>10 ⁷ operations

Transistor outputs	Short-circuit proof +5 to +30 VDC Indicates that the input conditions have been fulfilled Indicates that the output relays are activated 15 mA /output 2.4 V
External supply to Y13 Y14 Y24 Maximum load of Y14, Y24 Maximum voltage drop at maximum load	
LED indication	Supply voltage OK, the LED is on. Flashing light in case of under-voltage or overload Indicates that the input conditions are fulfilled. Indicates that the output relays are activated.
On ● In1 ● In2 ● <input checked="" type="checkbox"/> ● 1 <input checked="" type="checkbox"/> ● 2	
Mounting	35 mm DIN rail
Connection blocks (detachable)	1 Nm
Maximum screw torque Maximum connection area: Solid conductors Conductor with socket contact	1x4mm ² /2x1,5mm ² /12AWG 1x2,5mm ² /2x1mm ²
Protection class	IP 40 IEC 60529 IP 20 IEC 60529
Operating temperature range	-10°C to + 55°C (with no icing or condensation)
Operating humidity range	35% to 85%
Impulse Withstand Voltage	2.5kV
Pollution Degree	2
Performance (max.)	Category 4/PL e (EN ISO 13849-1:2008) SIL 3 (EN 62061:2005) PFH _d 9.55E-09
Conformity	2006/42/EC, 2006/95/EC, 2004/108/EC EN 954-1:1996, EN 62061:2005 EN ISO 13849-1:2008

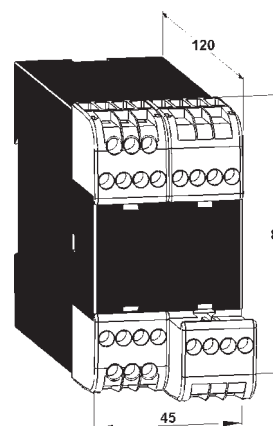

Connector blocks are detachable
(without cables having to be disconnected)

Safety relay

RT7

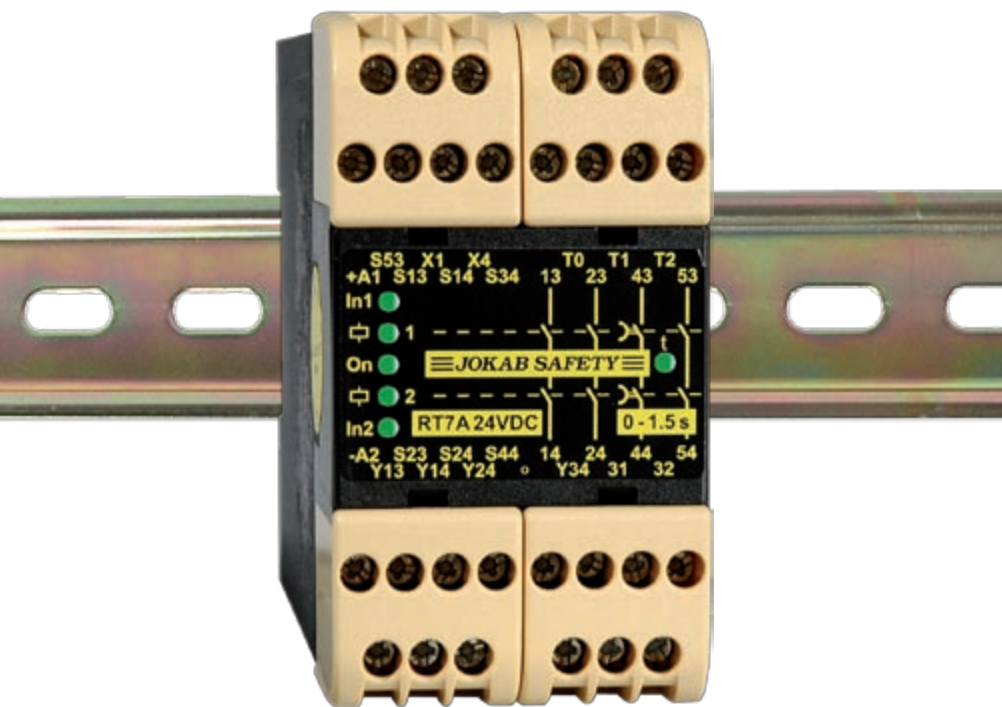

Approvals:



Safety relay for:

- Emergency stops
- Light curtains
- Three position devices
- Interlocked gates/hatches
- Magnetic switches
- Light beams
- Safety mats
- Contact strips
- Foot operated switches

Features:

- 4 NO/1 NC relay outputs, 2 NO outputs can be delayed for soft stops
- Delay times RT7A 0; 0,5; 1,0; 1,5 s RT7B 0; 1,0; 2,0; 3,0 s
- Five input options
- Single or dual channel input
- Manual supervised or automatic reset
- Test input for supervision of external contactors
- Width 45 mm
- LED indication of supply, inputs, outputs, short-circuit and low voltage level
- Three voltage free transistor information outputs
- Supply 24 VDC, 24, 48, 115 or 230 VAC
- Quick release connector blocks

Universal relay with delayed outputs

The RT7 is a universal relay that can be used to supervise both safety devices and the internal safety of your machinery. In addition, you can select the safety level that is required for each installation. All this is possible because the RT7 has the most versatile input options arrangement available on the market. The RT7 can therefore replace many other relays.

The RT7 has four (4 NO) dual safety outputs of which two may be delayed for up to three seconds in order to achieve a safe and 'soft' stop. A 'soft' stop allows machinery to brake and stop gently before power is removed. A 'soft' stop has many benefits: the machinery life will be prolonged, processed products will not be damaged, and restarts from the stopped position are made possible and easier.

Another option with the RT7 is manual or automatic resetting. A manual supervised reset is used for gates and other safety devices that can be bypassed, while an automatic reset is used for small safety hatches if deemed appropriate from a risk point of view.

In addition, the RT7 has information outputs that follow the inputs and outputs of the relay. These outputs indicate if for example a gate is opened or closed, if there is a delay or if the relay needs to be reset.

Choose the RT7 to simplify your safety circuits and reduce your costs.

Inputs

The RT7 can be configured to operate in either of the following input options:

1. Single channel, 1 NO contact from +24 VDC, safety category 1, up to PL c
2. Dual channel, 2 NO contacts from +24 VDC, category 3, up to PL d
3. Dual channel, 1 NO, 1 NC contact from +24 VDC, category 4, up to PL e
4. Dual channel, 1 NO contact from 0V and 1 NO contact from +24 VDC, category 4, up to PL e
5. Safety mats/contact strips, 1 'contact' from 0V and 1 'contact' from +24 VDC, category 3, up to PL d

When the input/inputs are activated and the test/supervised reset is complete, relays 1,2,3 and 4 are activated. Relays 1 and 2 are immediately de-energized when the inputs are deactivated in accordance with the input option selected. Relays 3 and 4 are either de-energized immediately or after the selected time delay. All the relays (1,2,3 and 4) must be de-energized before the RT7 can be reset.

Transistor output status information

The RT7 has three(3) voltage free transistor outputs that can be connected to a PLC, computer or other monitoring device. These outputs give the input and output status of the relay.

Reset and testing

The RT7 has two reset options; manual and automatic.

The manual supervised reset is utilised when the RT7 is used to monitor safety devices that can be bypassed, i.e. to ensure that the outputs of the safety relay do not close just because the gate is closed.

The automatic reset should only be used if acceptable from a risk point of view. The RT7 can also test (supervise), if for example, contactors and valves etc are de-energized/de-activated before a restart is allowed.

Indication of low voltage

The 'On' LED will flash if the relay voltage falls below an acceptable level. This indication will also be given if a monitored safety mat/contact strip is actuated. See connection option 5.

Safety level

The RT7 has internal dual and supervised safety functions. Power failure, an internal faulty component or external interference will not present a risk to options with the highest safety level. A manual reset requires that the reset input is closed and opened before the safety relay outputs are activated. A short-circuit or a faulty reset button is consequently supervised.

When the RT7 is configured for dual channel input, both the inputs are supervised for correct sequence operation before the unit can be reset. The input options 3 and 4 have the highest safety levels as all short-circuits and power failures are supervised. This in combination with internal current limitation makes the relay ideal for supervision of safety mats and contact strips.

Regulations and standards

The RT7 is designed and approved in accordance with appropriate directives and standards. Se tekniska data.

Connection examples

For examples of how our safety relays can solve various safety problems, see the section "Connection examples".

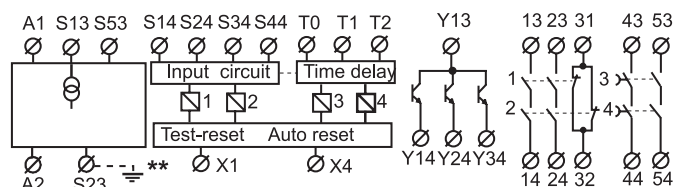

**Only for AC supply

Connection examples – RT7

DC supply

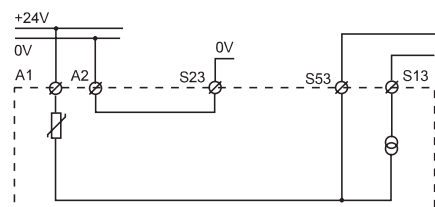

The RT7 DC option should be supplied with +24 V on A1 and 0 V on A2.

AC supply

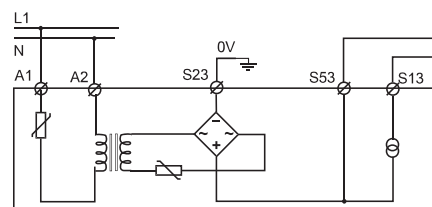

The RT7 AC option should be supplied with the appropriate supply voltage via connections A1 and A2.

The S23/⊥ must be connected to protective earth

DC-supply of AC-units

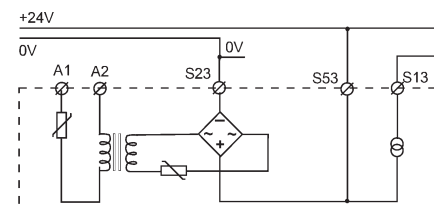

Samtliga AC-moduler kan också matas med +24 VDC på S53 och 0V på S23.

NOTE

With both DC and AC modules, if cable shielding is used this must be connected to an earth rail or an equivalent earth point.

Connection of safety devices - RT7 A/B

1. SINGLE CHANNEL, 1 NO from +24V



The input (contact to S14) must be closed before the outputs can be activated. When the input contact is opened the relay safety output contacts open.

2. DUAL CHANNEL, 2 NO from +24V

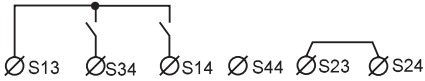

Both input contacts (S14 and S34) must be closed before the relay outputs can be activated. The safety relay contacts will open if one or both of the input contacts are opened. Both the input contacts must be opened before the relay can be reset. A short-circuit between the inputs S14 and S34 can only be supervised if the device connected to the inputs has short-circuit supervised outputs, e.g. JOKAB Focus light curtains.

3. DUAL CHANNEL, 1 NO, 1 NC from +24V

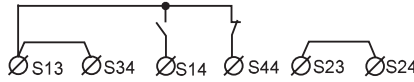

One input contact must be closed (S14) and one opened (S44) before the relay outputs can be activated. The safety relay contacts will open if one or both of the inputs change state or in the case of a short-circuit between S14 and S44. Both inputs must be returned to their initial positions before the relay outputs can be reactivated.

4. DUAL CHANNEL, 1 NO from +24V, 1 NO from 0V



Relay functions as option 2, but a short-circuit, in this case between inputs S14 and S24, is supervised (safety outputs are opened).

5. Safety mat/Contact strip

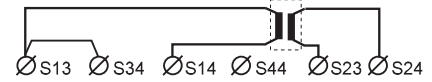

Both 'contact' inputs from an inactivated safety mat/contact strip, must be made in order to allow the RT7 relay outputs to be activated. When the safety mat/contact strip is activated or a short-circuit is detected across S14-S23, the relay will de-energize (safety outputs open) and the 'ON' LED will flash. As output S13 has an internal current limit of 70 mA, the RT7 will not be overloaded when the mat/contact strip is activated or a short circuit is detected.

Reset connections - RT7 A/B

Manual supervised reset

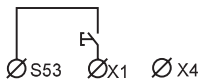

The manual supervised reset contact connected to input X1 must be closed and opened in order to activate the relay outputs.

Automatic reset



*connected to S13 for safety mat/contact strip

Automatic reset is selected when S53, X1 and X4 are linked. The relay outputs are then activated at the same time as the inputs.

Testing external contactor status

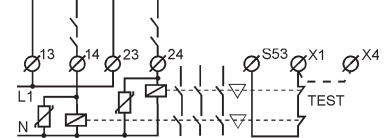

Contactors, relays and valves can be supervised by connecting 'test' contacts between S53 and X1. Both manual supervised and automatic reset can be used.

Output connections - RT7 A/B

Relay outputs

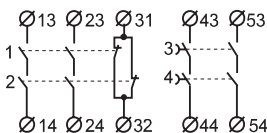

The RT7 has four (4 NO) safety outputs of which two can be delayed, and 1 NC information output.

In order to protect the RT7 output contacts it is recommended that loads (inductive) are suppressed by fitting correctly chosen VDR's, diodes etc. Diodes are the best arc suppressors, but will increase the switch off time of the load.

***NOTE

These outputs are only for information purposes and must not be connected to the safety circuits of the machinery.

Transistor outputs

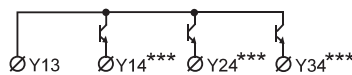

The RT7 has three(3) voltage free transistor information outputs.

The transistor outputs are supplied with voltage to Y13 either from S53 (+24V) or externally from 5 to 30 VDC. Y14, Y24 and Y34 follow the inputs and outputs as follows:

- Y14 becomes conductive when the relay input conditions are fulfilled.
- Y24 becomes conductive when both the output relays are activated.
- Y34 becomes conductive when both the delay output relays are activated.

Time delay outputs

RT7A	RT7B	T0	T1	T2	RT7A	RT7B	T0	T1	T2
0.0s	0.0s				1.0s	2.0s			
0.5s	1.0s				1.5s	3.0s			

Time delays are selected by linking the appropriate T0, T1 and T2 connections.

When a stop signal is detected a program stop command is first given to the PLC/servo which brakes the dangerous machine operations in a 'soft' and controlled way.

The delayed relay safety outputs will then turn off the power to the motors, i.e. when the machinery has already stopped. It takes usually around 0.5 to 3 seconds for a dangerous action to be stopped softly.

Technical data - RT7 A/B		
Manufacturer	ABB AB/Jokab Safety, Sweden	
Article number/Ordering data	RT7B 24DC 3 s 2TLJ010028R1000 115AC 3 s 2TLJ010028R1400 230AC 3 s 2TLJ010028R1500 RT7A 24DC 1,5 s 2TLJ010028R2000 115AC 1,5 s 2TLJ010028R2400 230AC 1,5 s 2TLJ010028R2500	
Colour	Black and beige	
Weight	405 g (24 VDC) 550 g (24-230 VAC)	
Supply Voltage (A1-A2)	24 VDC +15/-20%, 24/48/115/230 VAC, ±15%, 50-60 Hz	
Power consumption DC supply, nominal voltage AC supply, nominal voltage	4.6 W 8.8 VA	
Connection S13 Short-circuit protected voltage output, 70 mA ±10% current limitation. Is used for the inputs S14, S34 and S44.		
Connection S53 Short-circuit protected voltage output, internal automatic fuse, max 270 mA. Is used for the reset and autoreset inputs X1 and X4.		
Connection S23 0V connection for input S24.		
Safety inputs S14 (+) input S24 (0V) input S34 (+) input S44 (+) input	20 mA 20 mA 20 mA 25 mA	
Reset input X1 Supply for reset input Reset current Minimum contact closure time for reset	+ 24VDC 600 mA current pulse at contact closure, then 30 mA. 100 ms	
Maximum external connection cable resistance at nominal voltage for S14, S24, S34 S44, X1	300 Ohm 150 Ohm	
Response time At Power on DC/AC When activating (input-output) When deactivating (input-output) At Power Loss	<90/<140 ms <20 ms <20 ms <80 ms	
Delay time options RT7A RT7B	0; 0.5; 1.0; 1.5 secs 0; 1.0; 2.0; 3.0 secs	
Relay outputs NO direct (relays 1/2) NO direct or delayed (relays 3/4) NC (relays 1/2) Maximum switching capacity Relays 1/2 Resistive load AC Inductive load AC Resistive load DC Inductive load DC Relays 1/2 total	2 2 1 6A/250 VAC/1500 VA AC15 240VAC 2A 6A/24 VDC/150 W DC13 24VDC 1A Max 9A distributed on all contacts	
Relays 3/4 Resistive load AC Inductive load AC Resistive load DC Inductive load DC	6A/230 VAC/1380 VA AC15 230VAC 4A 6A/24VDC/144W DC13 24VDC 2A	

Relays 3/4 total	Max 6A distributed on all contacts
Contact material	AgSnO ₂ + Au flash
Fuses output 1/2 (external) Fuses output 3/4 (external)	5A gL/gG 3A gL/gG
Conditional short-circuit current (1 kA), each output	6A gG
Mechanical life	>10 ⁷ operations
Transistor outputs External supply to Y13 Y14 Y24 Y34 Maximum load of Y14,Y24, Y34 Maximum voltage drop at maximum load	+5 to +30 VDC Indicates that the input conditions are fulfilled Indicates that the output relays 1/2 are activated Indicates that the delay output relays 3/4 are activated 15 mA /output 2.4 V
LED indication On ● In1 ● In2 ● ☑ ● 1 ☑ ● 2 t ●	Supply voltage OK, the LED is on. Flashing light in case of under-voltage or overload. Indicates that the input conditions are fulfilled. Indicates that the output relays 1/2 are activated. Indicates that the delay output relays 3/4 are activated.
Mounting Rail	35 mm DIN rail
Connection blocks (detachable) Maximum screw torque Maximum connection area: Solid conductors Conductor with socket contact	1 Nm 1x4mm ² /2x1,5mm ² /12AWG 1x2,5mm ² /2x1mm ²
Protection class Enclosure Connection blocks	IP 40 IEC 60529 IP 20 IEC 60529
Operating temperature range 24VDC 24-230VAC	-10° C to + 55° C (with no icing or condensation) -10° C to + 45° C (with no icing or condensation)
Operating humidity range	35% to 85%
Impulse Withstand Voltage	2.5kV
Pollution Degree	2
Performance (max.) The relays must be cycled at least once a year.	Category 4/PL e (EN ISO 13849-1:2008) SIL 3 (EN 62061:2005) PFH _d 9.55E-09
Conformity	2006/42/EC, 2006/95/EC, 2004/108/EC EN 954-1:1996, EN 62061:2005 EN ISO 13849-1:2008

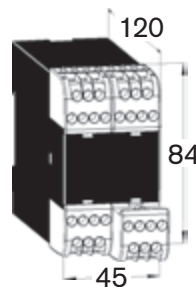

Connector blocks are detachable (without cables having to be disconnected)

Safety relay

RT9

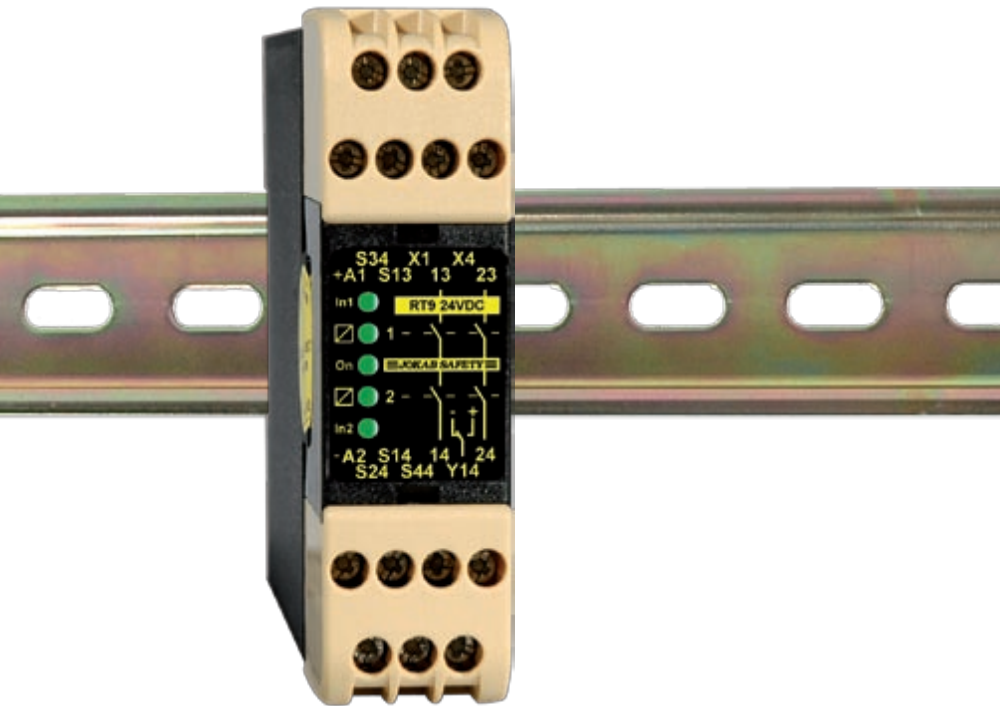

Approvals:



Safety relay for:

- Emergency stops
- Light curtains
- Three position devices
- Interlocked gates/hatches
- Magnetic switches
- Light beams
- Safety mats
- Contact strips
- Foot operated switches

Features:

- Five input options
- Single or dual channel input
- Manual supervised or automatic reset
- Test input for supervision of external contactors
- Width 22.5 mm
- LED indication of supply, inputs and outputs, short-circuit and low voltage level
- 2 NO relay outputs
- One changeover relay with a double information output
- Supply 24 VDC
- Quick release connector blocks

Would you like a small safety relay for all your safety applications?

Then choose the compact RT9 universal relay to supervise both your safety devices and the internal safety of your machinery. In addition, you can select the safety level that is required for each installation. All this is possible due to the RT9 offering the most versatile input option arrangement available on the market. The RT9 can therefore replace many other relays.

Other RT9 options include selection of either manual supervised or automatic resetting. The manual supervised reset can be used for gates and other safety devices that can be bypassed. Automatic reset can be used for small safety hatches, if deemed acceptable from risk assessment.

In addition, the RT9 has a double information output that will indicate e.g. if a gate is open or if the relay needs resetting.

The RT9 uses the latest component technology and modern assembly techniques to ensure a highly cost effective solution.

Choose the RT9 to simplify your safety circuits and reduce your costs.

Technical information – RT9

Inputs

The RT9 can be configured to operate in either of the following input options:

1. Single channel, 1 NO contact from +24VDC, category 1, up to PL c
2. Dual channel, 2 NO contacts from +24VDC, category 3, up to PL d
3. Dual channel, 1 NO, 1 NC contact from +24VDC, category 4, up to PL e
4. Dual channel, 1 NO contact from 0V and 1 NO contact from +24VDC, category 4, up to PL e
5. Safety mat/contact strips, 1 'contact' from 0V and 1 'contact' +24VDC, category 3, up to PL d

When the input/inputs are activated and the test/supervised reset is complete, relays 1 and 2 are energised. These are de-energised when the input/inputs are de-activated in accordance with the input option chosen or in case of a power failure.

Relays 1 and 2 must both be de-energised before the RT9 can be reset.

Relay output status information

The RT9 has a changeover contact relay output that can be connected to a PLC, control lamp, computer or similar. The output gives information about the status of the relay.

Reset and testing

The RT9 has two reset options; manual and automatic. The manual supervised reset can be used when the RT9 is monitoring safety devices that can be bypassed, i.e. to ensure that the outputs of the safety relay do not close just because a gate is closed. The automatic reset option should only be used if appropriate from a risk point of view.

Due to special internal circuits the RT9 can be automatically reset regardless of the operational voltage rise time, this being an important factor when large loads are started up on the same power supplies at the same time.

In addition, the RT9 can also test (supervise), if for example, contactors and valves etc are de-energised/de-activated before a restart is made.

Indication of low voltage

The 'On' LED will flash if the relay supply voltage falls below an acceptable level. This indication will also be given if a monitored safety mat/contact strip is actuated. Please see Connection option 5.

Safety level

The RT9 has internal dual and supervised safety functions. Power failure, an internal faulty component or external interference will not present a risk to options with the highest safety level. A manual reset requires that the reset input is closed and opened before the safety relay outputs are activated. A short-circuit or a faulty reset button is consequently supervised.

When the RT9 is configured for dual channel input, both the inputs are supervised for correct operation before the unit can be reset.

The input options 3 and 4 have the highest safety levels as all short-circuits and power failures are supervised. This in combination with an internal current limitation makes the relay ideal for supervision of safety mats and contact strips.

Regulations and standards

The RT9 is designed and approved in accordance with appropriate directives and standards. See technical data.

Connection examples

For examples of how our safety relays can solve various safety problems, please see the section "Connection examples".

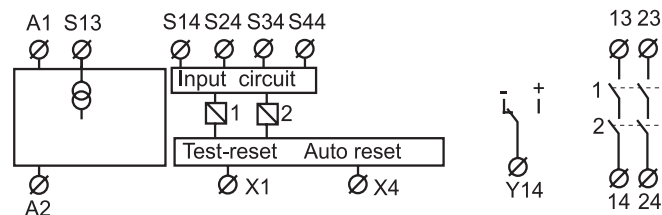

Connection of supply - RT9

DC supply

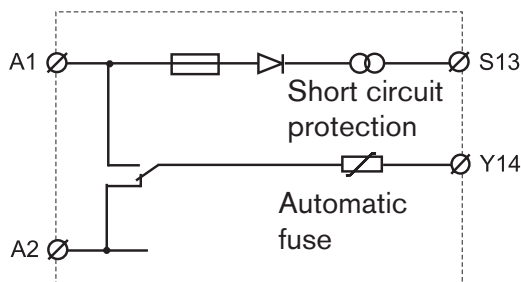

The RT9 should be supplied with +24 V on A1 and 0 V on A2.

NOTE

If cable shielding is used this must be connected to an earth rail or an equivalent earth point.

Connection of safety devices - RT9

1. SINGLE CHANNEL, 1 NO from +24V

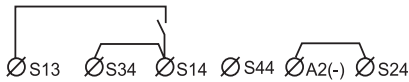

The input (contact to S14) must be closed before the outputs can be activated. When the input contact is opened, the relay safety output contacts open.

2. DUAL CHANNEL, 2 NO from +24V

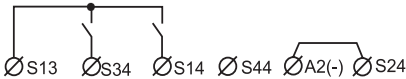

Both input contacts (S14 and S34) must be closed before the relay outputs can be activated. The safety relay contacts will open if one or both of the input contacts are opened. Both the input contacts must be opened and reclosed before the relay can be reset.

A short-circuit between inputs S14 and S34 can only be supervised if the device connected to the inputs has short-circuit supervised outputs, e.g. JOKAB Focus light curtains

3. DUAL CHANNEL, 1 NO, 1 NC from +24V

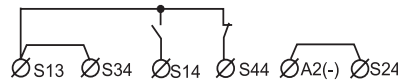

One input contact must be closed (S14) and one opened (S34) before the relay outputs can be activated.

The safety relay contacts will open if one or both of the inputs change state or in case of a short-circuit between S14 and S44. Both inputs must be returned to their initial status before the relay outputs can be reactivated.

4. DUAL CHANNEL, 1 NO from +24V, 1 NO from 0V



Relay functions as option 2, but a short-circuit, in this case between inputs S14 and S24, is supervised (safety outputs are opened).

5. Safety mat/Contact strip

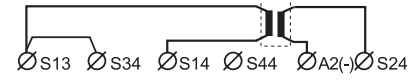

Both 'contact' inputs from a inactivated safety mat/contact strip must be made in order to allow the RT9 relay outputs to be activated. When the safety mat/contact strip is activated or a short-circuit is detected across S14-S23, the relay will de-energize (safety contacts open) and the 'ON' LED will flash. As output S13 has an internal current limit of 70 mA, the RT9 will not be overloaded when the mat/contact strip is activated or a short-circuit is detected.

Reset connections - RT9

Manual supervised reset

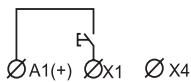

The manual supervised reset contact connected to input X1 must be closed and opened in order to activate the relay outputs.

Automatic reset

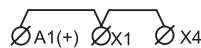

Automatic reset is selected when A1(+), X1 and X4 are linked. The relay outputs are then activated at the same time as the inputs.

Testing external contactor status

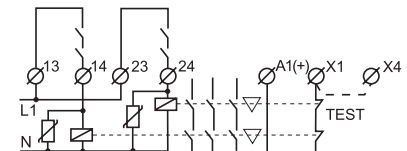

Contactors, relays and valves can be supervised by connecting 'test' contacts between A1(+) and X1. Both manual supervised and automatic reset can be used.

Output connections - RT9

Relay outputs

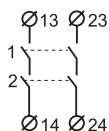

The RT9 has two (2 NO) safety outputs.

In order to protect the output contacts it is recommended that loads (inductive) are suppressed by fitting correctly chosen VDR's, diodes etc. Diodes are the best arc suppressors, but will increase the switch off time of the load.

Information outputs



The RT9 has a single changeover contact information relay output. The relay output Y14 is connected internally to 0V and 24V in the following way:

- Y14 is internally closed to 0V when the RT9 is not reset.
- Y14 is internally closed to +24V when the relay is reset.

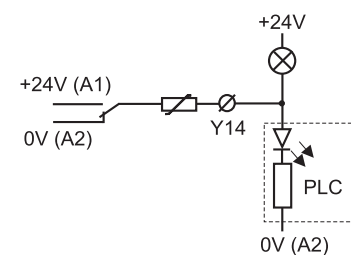

Technical data – RT9	
Manufacturer	ABB AB/Jokab Safety, Sweden
Article number/Ordering data RT9 24DC	2TLJ010029R0000
Colour	Black and beige
Weight	210 g
Supply Voltage (A1-A2)	24 VDC ±20%
Power consumption Nominal voltage	2 W
Connection S13	Short-circuit protected voltage output 70 mA ± 10% current limitation. Is used for the inputs S14, S34 and S44.
Input currents (at nominal supply voltage) S14 (+) input S24 (0V) input S34 (+) input S44 (+) input	30 mA 20 mA 20 mA 25 mA
Reset input X1 Supply for reset input Reset current Minimum contact closure time for reset Minimum contact closure time (at low limit voltage -20%)	+ 24VDC 300 mA current pulse at contact closure, then 30 mA 80 ms 100 ms
Maximum external connection cable resistance at a nominal voltage for S14, S24, S34 S44, X1	300 Ohm 150 Ohm
Response time At Power on When activating (input-output) When deactivating (input-output) At Power Loss	<100 ms <20 ms <20 ms <80 ms
Relay outputs NO Maximum switching capacity Resistive load AC Inductive load AC Resistive load DC Inductive load DC Max. total switching capacity: Minimum load Contact material	2 6A/250 VAC/1500 VA AC15 240VAC 2A 6A/24 VDC/150 W DC13 24VDC 1A 8A distributed on all contacts 10 mA/10V (if load on contact has not exceeded 100 mA) Ag+Au flash
Fuses Output (External)	5A gL/gG
Conditional short-circuit current (1 kA) Mechanical life	6A gG 10 ⁷ operations
Relay information output Y14 (Changeover contacts) -(0V) +(24V) Maximum load of Y14 Short-circuit protection for information output	Indicates that RT9 is not reset. Indicates that RT9 is reset. 250 mA Internal automatic fuse

LED indication On ● In1 ● In2 ● ☑ ● 1 ☑ ● 2	Supply voltage OK, the LED is on. Flashing light in case of under-voltage, overload or current limiting Indicates that the input conditions are fulfilled. Indicates that the output relays have been activated.
Mounting Rail	35 mm DIN rail
Connection blocks (detachable) Maximum screw torque Maximum connection area: Solid conductors Conductor with socket contact	1 Nm 1x4mm ² /2x1,5mm ² /12AWG 1x2,5mm ² /2x1mm ²
Protection class Enclosure Connection blocks	IP 40 IEC 60529 IP 20 IEC 60529
Operating temperature range	-10°C to + 55°C (with no icing or condensation)
Operating humidity range	35% to 85%
Impulse Withstand Voltage	2.5kV
Pollution Degree	2
Performance (max.) The relays must be cycled at least once a year.	Category 4/PL e (EN ISO 13849-1:2008) SIL 3 (EN 62061:2005) PFH _d 9.55E-09
Conformity	2006/42/EC, 2006/95/EC, 2004/108/EC EN 954-1:1996, EN 62061:2005 EN ISO 13849-1:2008

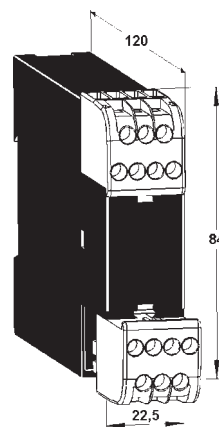

Connector blocks are detachable (without cables having to be disconnected)

Safety relay

JSBRT11

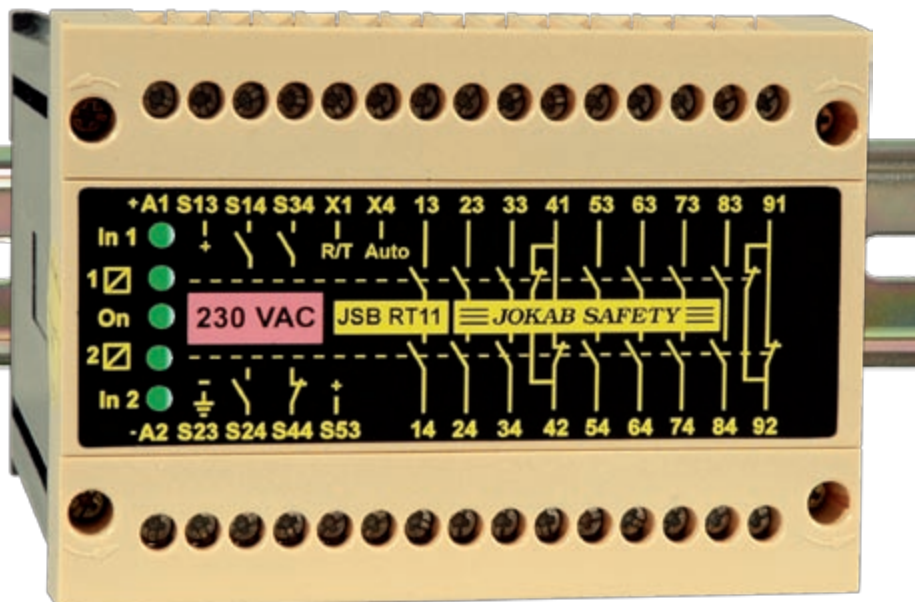

A flexible safety relay with many outputs

The JSBRT11 has been designed to provide the safety system circuit designer with the ability to select from both a range of input connection configurations and either automatic or supervised reset.

The unit can be hardwire configured to operate in either of the following input configurations:

- Mode 1: Single Channel (1 NO contact from +24 VDC), category 1 PL c
- Mode 2: Dual Channel (2 NO contacts from +24 VDC), category 3 PL d
- Mode 3: Dual Channel (1 NO, 1NC contacts from + 24 VDC), category 4 PL e.
- Mode 4: Dual Channel (1 NO contact from 0 V and 1 NO contact from + 24 VDC), safety category 4.

In addition the unit can also be used to test that contactors and valves have fallen/returned to their 'reset' state before a new 'start' signal is given.

Safety level

The JSBRT11 has dual and monitored internal safety functions. Power failure, internal component failures or external interference (with the exception of short circuiting of input contact when used in a single channel input mode) do not result in a dangerous function.

When wired for supervised reset, should a short circuit appear across the reset input the relay will not automatically reset when the input/inputs are made. Only when the supervised reset input is made and broken will the relay reset.

The JSBRT11 provides detection of contact failure in the inputs when wired in dual channel mode. Both inputs have to be opened and closed in order to enable the reactivation of the relay.

The highest safety level of the JSBRT11 is in configuration mode 3 and 4 because all short circuits are supervised i.e. a short circuit between the inputs leads to a safe state as the outputs drop out.

Regulations and standards

The JSBRT11 is designed and approved in accordance with appropriate directives and standards. See technical data.

Connection examples

For examples of how our safety relays can solve various safety problems, please see the section "Connection examples".

Approvals:



Safety relay for:

- Emergency stop
- Light curtains
- Three position devices
- Interlocked gates/hatches
- Magnetic switches
- Light beams
- Foot operated switches

Features:

- Selectable inputs and safety category
- Manual supervised or automatic reset
- Width 100 mm
- LED indication for supply, inputs and outputs
- 7 NO + 2 NC relay outputs
- Supply 24 VDC 24, 48, 115 or 230 VAC
- Quick release connector blocks

Technical data – JSBRT11	
Manufacturer	ABB AB/Jokab Safety, Sweden
Article number/Ordering data	24 DC 115 AC 230 AC
Colour	Black and beige
Power supply A1 - A2	24 VDC ± 15% 24, 48, 115, 230 VAC ± 15%, 50-60 Hz
Power consumption	3,2 W/7,9 VA
Relay Outputs	7 NO and 2 NC
Max. switching capacity	Resistive load AC 6A/250 VAC/1500 VA Inductive load AC AC15 240VAC 2A Resistive load DC 6A/24 VDC/150 W Inductive load DC DC13 24VDC 1A
Max. total switching capacity	21A distributed on all contacts
Min. load	10mA/10 V (if load on contact has not exceeded 100 mA)
Contact material	AgSnO ₂ + Au flash
Fuses Output (External)	6A gL/gG
Conditional short-circuit current (1 kA)	6A gG
Max. Input wire res. at nom. voltage	200 Ohm (S14,S24,S34,X1,X4); 100 Ohm (S44)
Response time at deactivation (input-output)	<20 ms
Response time at activation (input-output)	<30 ms

Terminals (Max. screw torque 1 Nm)	Single strand: 1x4 mm ² /2x1.5 mm ² Conductor with socket contact: 1x2.5 mm ² /2x1mm ²
Mounting	35 mm DIN-rail
Protection class	enclosure IP 40 IEC 60259 terminals IP 20 IEC 60259
Impulse Withstand Voltage	2.5kV
Pollution Degree	2
Operating temperature range	-10°C to +55°C (with no icing or condensation)
Operating humidity range	35% to 85%
Function indication	Electrical Supply, Input 1 and 2, Output relays 1 and 2
Weight	610 g (24 VDC) 790 g (24- 230 VAC)
Performance (max.)	Category 4/PL e (EN ISO 13849-1:2008) SIL 3 (EN 62061:2005) PFH _d 1.69E-08
Conformity	2006/42/EC, 2006/95/EC, 2004/108/EC EN 954-1:1996, EN 62061:2005 EN ISO 13849-1:2008

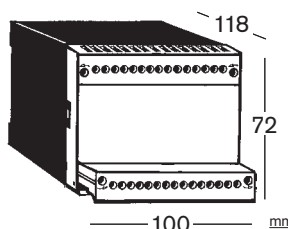

Connector blocks are detachable (without cables having to be disconnected)

Technical description – JSBRT11

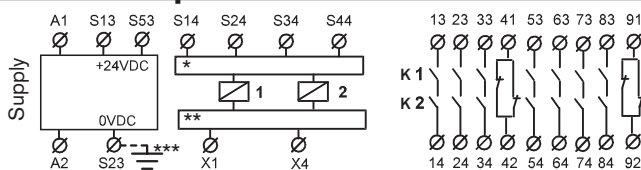

*Supervision circuit **Test and Automatic reset circuit *** Only for AC-supply

The supply voltage is connected across A1 and A2. The input connection configuration and type of reset required is set by connecting the unit as shown in the diagrams below.

When the input/inputs and the test/supervised reset are made K1 and K2 energise. K1 and K2 will de-energise if the power is disconnected or a stop signal is given in accordance to the configuration mode wired. Both K1 and K2 have to be de-activated before the outputs of the JSBRT11 can be closed again.

Configuration mode 1.

When the single input opens both K1 and K2 relays are deactivated.

Configuration mode 2.

Both inputs have to be closed in order to enable the unit to be activated. A stop signal is given if both or one input is opened. Both inputs have to be opened and reclosed in order to enable the reactivation of the unit. If the possibility of short circuits between the inputs cannot be excluded, configuration mode 3 or 4 should be used in order to reach the highest safety level.

Configuration mode 3.

One input has to be closed and the other input has to be opened in order to enable the unit to be activated. A stop signal is given if both or one input change state.

Both inputs have to change state in order to give a dual stop function and to allow a new start after stop.

Configuration mode 4

Operation as mode 2 but short circuits between the inputs leads to a safe state i.e. the relays inside the JSBRT11 will drop out.

Supervised reset connection.

The input to X1 (see diagram below) has to be closed and opened in order to activate the unit, after input/inputs are made according to the configuration mode selected. This mode is selected when X1 - X4 is open-circuit.

Automatic reset connection.

The input has to be closed in order to activate the unit after input/inputs are made according to the configuration mode selected. This mode is selected when a connection between X1 and X4 is made.

Test.

Test contacts of contactors can be connected between S53 and X1 for supervision.

Electrical connection – JSBRT11

SINGLE CHANNEL *, 1 NO from +24V



DUAL CHANNEL*, 2 NO from +24V



It is recommended that all switched loads are adequately suppressed and/or fused in order to provide additional protection for the safety contacts.

DUAL CHANNEL*, 1 NO, 1 NC from +24V

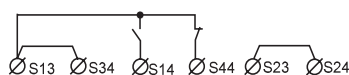

DUAL CHANNEL*, 1 NO from +24V, 1 NO from 0V

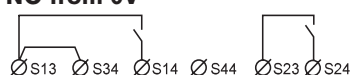

* With the input conditions shown, the JSBRT11 is in its de-energized state, i.e. output contacts are open.

Supervised manual reset

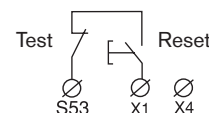

Automatic reset

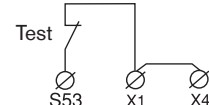

Safety relay

JSBR4

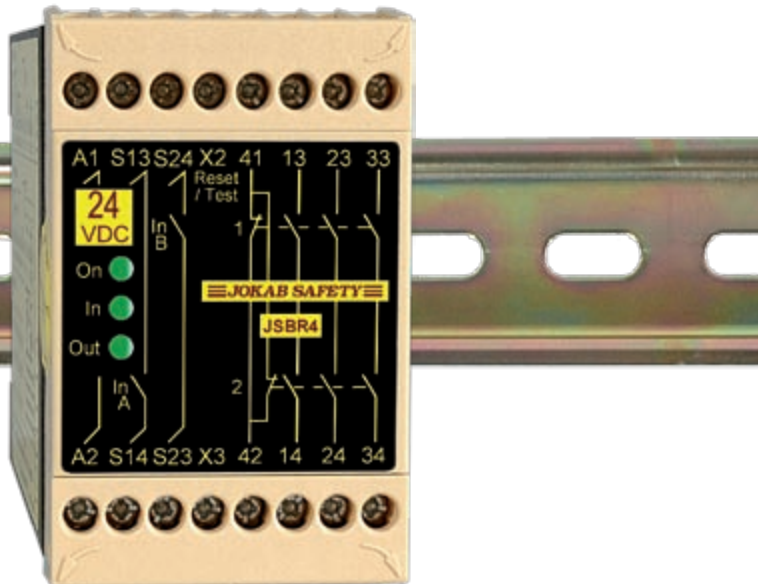

Approvals:



Safety relay for:

- Two-hand devices of type IIIc
- Emergency stop
- Three position devices
- Interlocked Gates/Hatches
- Contact strips
- Safety mats
- Foot operated switches

Features:

- Two channel with concurrency requirement of 0,5 s
- Supervised reset
- Test input
- Width 45 mm
- LED indication for supply, inputs and outputs
- 3 NO/1NC relay outputs
- Supply 24 VDC, 24, 48, 115 or 230 VAC
- Quick release connector blocks

A universal relay for two-hand- and many other safety devices

The JSBR4 has two inputs, which both have to be closed to keep the safety output contacts closed. A short-circuit across the inputs will cause the output contacts to open. The inputs can however be subjected to a continuous short-circuit without damaging the safety relay.

In order to make the safety outputs close the reset input must be closed and opened. In this way an unintentional reset is prevented in the case of a short-circuit in the reset button cable or if the button gets jammed in the actuated position. The reset input can also be used for test/supervision to ensure that contactors or valves have returned to their initial off/stop position before a new start can be allowed by the safety relay.

When the JSBR4 is used as a two-hand device relay, both buttons have to be pressed within 0.5 seconds of each other in order to close the outputs.

When the JSBR4 is used for Safety Mats and Safety Strips the "stop" condition is given following detection of a short-circuit between input channels A and B. The safety mat, safety strip or the relay will not be damaged by a continuous short-circuit. This also gives the advantage that if there is a failure between the inputs in the installation, the safety relay will not be damaged.

Safety level

The JSBR4 has a twin supervised safety function. Component failure, short-circuit or external disturbance (e.g. loss of power supply) will not prevent the safe function of the relay. This is valid both for the inputs A and B as well as for the reset input. The JSBR4 operates at the highest safety level for safety relays (PL e according to EN ISO 13849-1).

Regulations and standards

The JSBR4 is designed and approved in accordance with appropriate directives and standards. See technical data. The JSBR4 complies with the highest safety level for the connection of a two-hand device of type IIIc in accordance with EN 574.

Connection examples

For examples of how our safety relays can solve various safety problems, please see the section "Connection examples".

Technical data – JSBR4

Manufacturer	ABB AB/Jokab Safety, Sweden
Article number/Ordering data	2TLJ010002R0000 24 DC 24 AC 115 AC 230 AC
Colour	Black and beige
Power supply	24 VDC ± 15% 24/48/115/230 VAC ± 15%, 50 - 60 Hz
Power consumption	1,3 W/3,3 VA
Relay Outputs	3 NO + 1 NC
Max. switching capacity	Resistive load AC Inductive load AC Resistive load DC Inductive load DC
Max. res. load total switching capacity:	12A distributed on all contacts
Min. load	10mA/10 V (if load on contact has not exceeded 100 mA)
Contact material	Ag + Au flash
Fuses Output (External)	5A gL/gG
Conditional short-circuit current (1 kA)	6A gG
Max. Input wire res. at nom. voltage	300 Ohm (S13 - S14 and S23 - S24)
Response time at deactivation	< 20 ms (145 ms at power loss)

Terminals (Max. screw torque 1 Nm)	Single strand: 1 x 2,5 mm ² /2 x 1 mm ² . Conductor with socket contact: 1 x 4 mm ² /2 x 1,5 mm ² .
Mounting	35 mm DIN-rail
Protection class enclosure/terminals	IP 40/20 IEC 60529
Operating temperature range	-10°C to +55°C (with no icing or condensation)
Impulse Withstand Voltage	2.5kV
Pollution Degree	2
Operating humidity range	35% to 85%
LED indication	Electrical Supply, Inputs, Outputs
Weight	350 g (24 VDC), 460 g (24-230 VAC)
Values (With Proof test interval 1 year)	Safety Category 4 according to EN 954-1, PL e, SIL 3, PFH _d 1.35E-08
Conformity	2006/42/EC, 2006/95/EC, 2004/108/EC EN 954-1:1996, EN 62061:2005 EN ISO 13849-1:2008

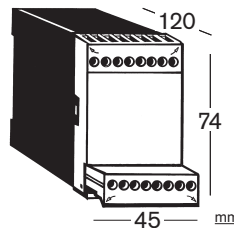

Connector blocks are detachable (without cables having to be disconnected)

Technical description – JSBR4

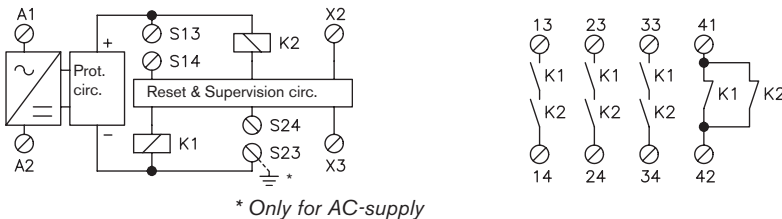

The electrical supply is connected across A1 and A2. After Voltage reduction and Rectification (AC-versions) or reverse polarity protection (DC-version) there is an overload protection-circuit.

When the inputs S13-S14 and S23-S24 have closed and the reset is made, the relays K1 and K2 are activated. A dual stop signal is given when K1 and

K2 drop, due to short circuiting between the inputs, opening of the inputs or power failure. If one input is opened the other input must also be opened for K1 and K2 to be activated again.

The monitoring circuit checks K1 and K2 and that the reset circuit to X2 is both closed and opened before K1 and K2 are energized. Both the stop and reset function therefore comply

with the requirement that a component fault, short circuit or external interference do not result in a dangerous function.

The safety outputs consist of contacts from K1 and K2 connected internally in series across terminals 13 - 14, 23 - 24 and 33 - 34. These contacts are used to cut the power to components which stop or prevent hazardous movements/functions. It is recommended that all switched loads are adequately suppressed and/or fused in order to provide additional protection for the safety contacts.

Note: Output 41-42 is intended for indication purposes only, e.g. gate opened. No load between S14 and S24 allowed.

Electrical connection – JSBR4

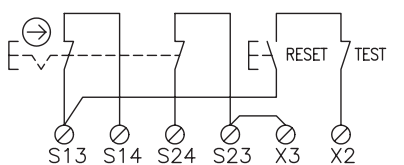

Emergency stop with manual resetting.

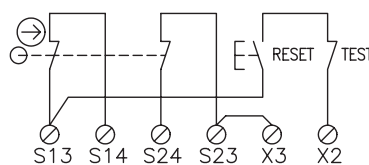

Interlocked gate with manual reset.

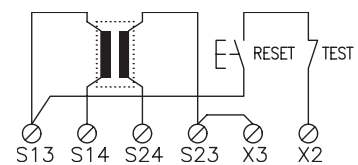

Contact mat/strip with manual reset.

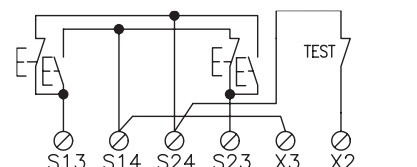

Two hand device with buttons in separate or same enclosure. Buttons to be pressed in within 0.5 s of each other. Footpedal switches can be connected in the same configuration.

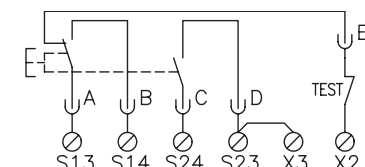

Enabling device, JSBD4. Stop condition is given in both top and bottom PB positions.

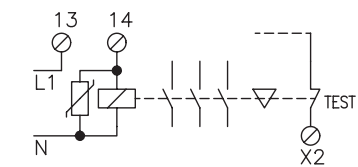

Control and supervision of external conductor, relay, valve or ABB Jokab Safety's expansion relays.

Safety relay

JSBT4

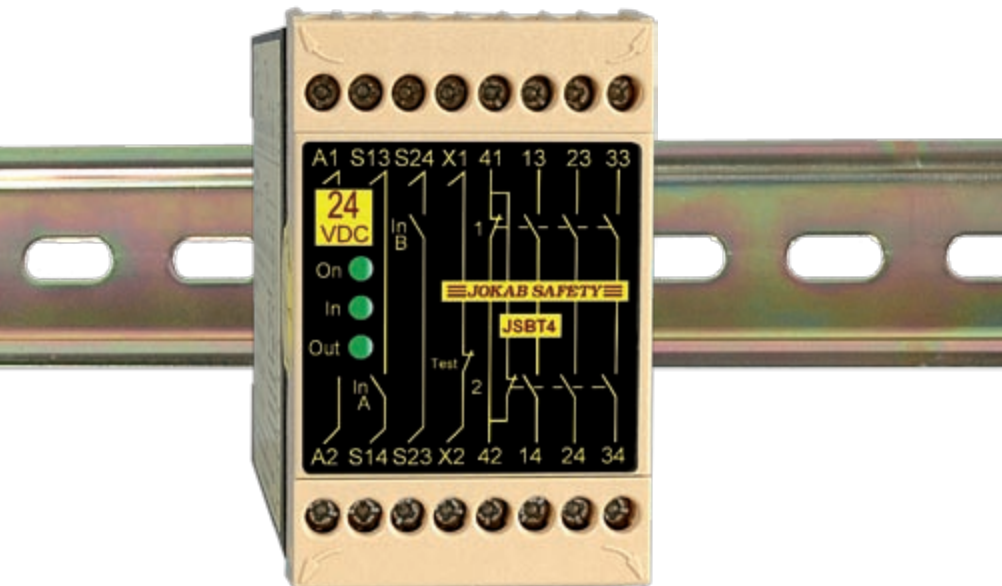

Approvals:



Safety relay for:

- Emergency stops
- Three position devices
- Interlocked Hatches
- Safety mats
- Contact strips
- Foot operated switches

Features:

- Dual input channels synchronism 0.5 s
- Test input
- Width 45 mm
- LED indications for power on, inputs and outputs
- 3 NO/1NC relay outputs
- Supply 24 VDC, 24, 48, 115 or 230 VAC
- Quick release connector blocks

Safety relay with synchronised dual input channels (within 0.5s)

The JSBT4 has two inputs, both of which have to be closed in order to keep the safety output contacts closed. A short circuit between inputs A and B will cause the output contacts to open. The inputs can be continuously short circuited without damaging the safety relay.

For the outputs to close, the test input must be closed. The test input is intended to monitor that contactors or valves have dropped/returned before a new start is permitted.

This test input must not be confused with the reset function required for gates that a person can walk through and where there is a high safety requirement (see JSBR4).

If the JSBT4 is used for safety Mats and safety Strips, the "stop" condition is given following detection of a short circuit. The safety mat, safety strip or the relay will not be damaged by a continuous short-circuit. This also provides the advantage that if there is a failure between inputs A and B in the installation, the safety relay will not be damaged.

Safety level

The JSBT4 has a twin supervised safety function. Component failure, short-circuit or external disturbance (e.g. loss of power supply) will not prevent the safe function of the relay. Safety category level 3 or 4, depending on use.

The true two-channel safety function has the advantage that the cabling installation demands for safety can be reduced, due to the fact that a short-circuit between the inputs will directly open the relay's safety outputs.

Regulations and standards

The JSBT4 is designed and approved in accordance with appropriate directives and standards. See technical data.

Connection examples

For examples of how our safety relays can solve various safety problems, please see the section "Connection examples".

Technical data – JSBT4

Manufacturer	ABB AB/Jokab Safety, Sweden
Article number/Ordering data 24 DC	2TLJ010004R0000
Colour	Black and beige
Power supply	24 VDC ± 15% 24/48/115/230VAC ± 15%, 50 - 60 Hz
Power consumption	1,6 W/3,8 VA
Relay Outputs	3 NO + 1 NC
Max. switching capacity Resistive load AC Inductive load AC Resistive load DC Inductive load DC	6A/250 VAC/1500 VA AC15 240VAC 2A 6A/24 VDC/150 W DC13 24VDC 1A
Max. res. load total switching capacity:	12A distributed on all contacts
Min. load	10mA/10 V (if load on contact has not exceeded 100 mA)
Contact material	Ag + Au flash
Fuses Output (External)	5A gL/gG
Conditional short-circuit current (1 kA)	6A gG
Max. Input wire res. at nom. voltage	300 Ohm (S13 - S14 and S23 - S24)
Response time at deactivation	< 20 ms, 145 ms with switched supply/power loss

Terminals (Max. screw torque 1 Nm) Single strand: Conductor with socket contact:	1 x 4 mm ² /2 x 1,5 mm ² 1 x 2,5 mm ² /2 x 1 mm ²
Mounting	35 mm DIN-rail
Protection class enclosure/ terminals	IP 40/20 IEC 60529
Operating temperature range	-10°C to +55°C (with no icing or condensation)
Impulse Withstand Voltage	2.5kV
Pollution Degree	2
Operating humidity range	35% to 85%
LED indication	Electrical Supply, Inputs, Outputs
Weight	350 g (24VDC), 460 g (24-230VAC)
Values (With Proof test interval 1 year)	Safety Category 4 according to EN 954-1, PL e, SIL 3, PFH _d 1.51E-08
Conformity	2006/42/EC, 2006/95/EC, 2004/108/EC EN 954-1:1996, EN 62061:2005 EN ISO 13849-1:2008

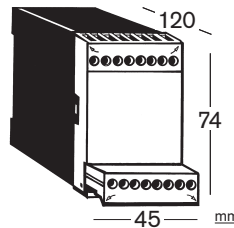

Connector blocks are detachable (without cables having to be disconnected)

Technical description – JSBT4

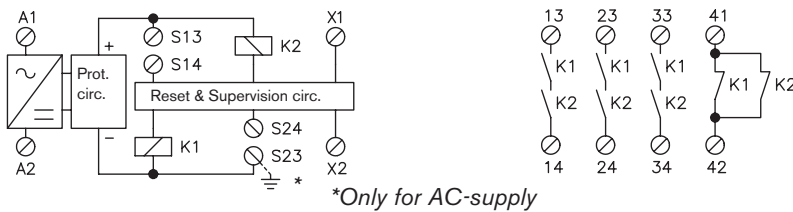

The electrical supply is connected across A1 and A2. After Voltage reduction and Rectification (AC-versions) or reverse polarity protection (DC-version) there is an overload protection-circuit.

When the inputs S13-S14 and S23-S24 are closed within 0.5 seconds of each other the relays K1 and K2 are energized. A dual stop signal is given, K1 and K2 de-energize, when there is a short circuit between or an opening of the inputs or at power loss. If one

input is opened the other one also has to be opened in order to activate K1 and K2 again. The test circuit, X1 - X2, has to be closed in order to activate the outputs, thereafter the test circuit can be opened or closed continuously. If the test circuit is closed after the inputs there is no requirement to close them within 0.5 seconds of each other.

The internal supervision circuit monitors the two Inputs and relays K1, K2. The stop function then fulfils the requirement that one

failure (short circuit, component, external disturbance) shall not prevent the safe function of the JSBT4.

The safety outputs consist of contacts from K1 and K2 connected internally in series across terminals 13 - 14, 23 -24 and 33 - 34. These contacts are used to cut the power to components which stop or prevent hazardous movements/functions. It is recommended that all switched loads are adequately suppressed and/or fused in order to provide additional protection for the safety contacts.

The NC output 41 -42 should only be used for monitoring purposes e.g. Indication lamp or PLC input etc. The output contacts are closed until the module is reset.

Note: Output 41-42 is intended for indication purposes only, e.g. gate opened. No load between S14 and S24 allowed.

Electrical connection – JSBT4

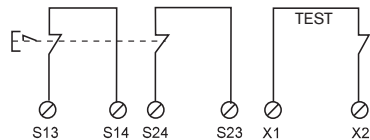

Emergency stop with automatic resetting.

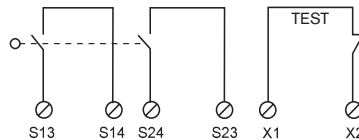

Interlocked hatch with automatic resetting.

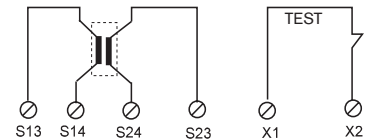

Contact mat/strip with automatic reset

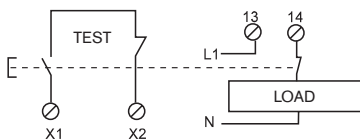

Monitoring to ensure that the Start button cannot stick in pressed position. Short circuiting over the closing contact is not monitored. The RT-series and JSBR4 have built in short circuiting monitored resetting.

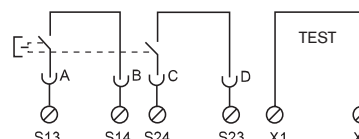

Enabling device, JSBD4. Stop condition is given in both top and bottom positions.

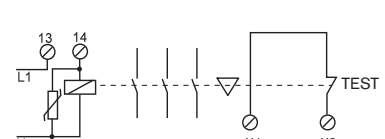

Control and supervision of external contactor, relay, valve or ABB Jokab Safety's expansion relays.

Safety relay/expansion relay

BT50(T)

Approvals:

TÜV Nord  

Safety relay for:

Emergency stop
Interlocked hatch
Expansion of Pluto

Features:

Single and “dual” channel
Test/“reset” input
Width 22.5 mm
LED indication
3 NO/1NC relay outputs
Supply 24 VDC
Quick release connector blocks
BT50 - Additional power terminals
BT50T - One changeover relay with a double information output (Y14)
BT50T - Delay times selectable from 0 - 1.5 s

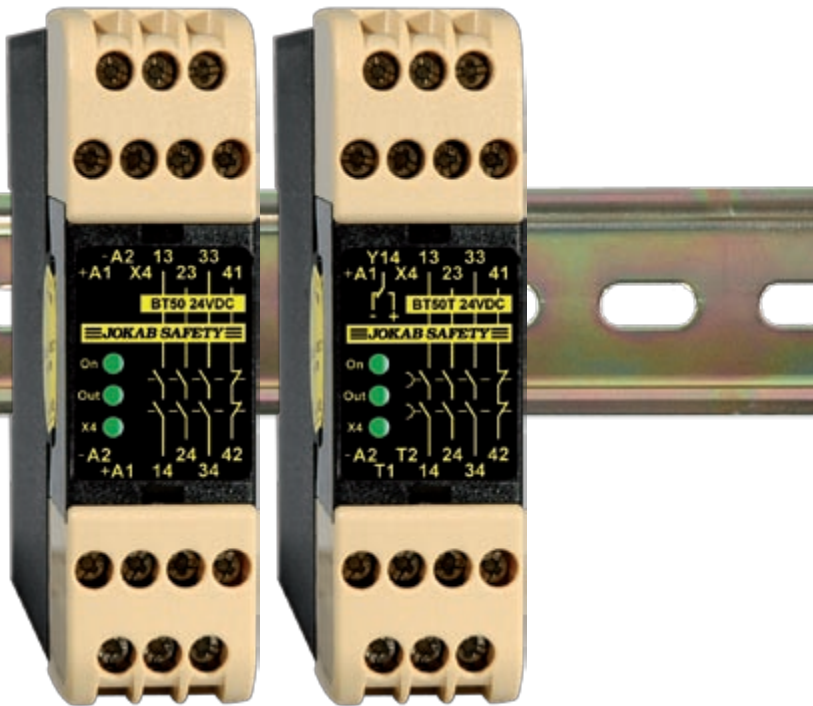

Safety relay/expansion relay to Pluto

The BT50 is designed to connect safety devices, such as emergency stops, directly in the voltage supply circuit to the relay. Despite a maximum built-in width of 22.5 mm the relay is very powerful.

With 3NO safety outputs, 1NC output (for monitoring purposes), a test input and complete internal supervision, the BT50 is quite unique. In addition, delayed outputs (BT50T) can be ordered.

In order for the safety outputs to close, the supply voltage, e.g. by means of an emergency stop button, must be connected to A1 and A2 and the test input closed. After actuation of the relay the test input can be opened again.

The test input is intended to supervise that contactors or valves have dropped/returned before a new start can be permitted. The test input can also be used for starting and the start button can be supervised (see the connection example on the next page).

More outputs

By connecting a BT50 to a safety relay/PLC it is easy to increase the number of safe outputs. This means that an unlimited number of dangerous machine operations and functions can be stopped by using just one safety-PLC.

Safety level

BT50 have an internal redundant and monitored safety function. Power failure, internal component faults or external interference cannot result in dangerous functions.

Input via A1 on its own is not protected from short

circuiting, and therefore installation is critical for the safety level to be achieved. To achieve a higher safety level a screened cable can be used and/or connection made to both A1 and A2 (see the example on the next page).

Regulations and standards

The BT50 is designed and approved in accordance with appropriate directives and standards. See technical data.

Connection examples

For examples of how our safety relays can solve various safety problems, please see the chapter “Connection examples”.

Technical data – BT50(T)

Manufacturer	ABB AB/Jokab Safety, Sweden
Article number/Ordering data BT50 BT50T	2TLJ010033R0000 2TLJ010033R1000
Colour	Black and beige
Operational voltage	24 VDC + 15%/-25%
Power consumption	1,4 W/1,8 W
Relay Outputs	3 NO + 1 NC
Max. switching capacity Resistive load AC Inductive load AC Resistive load DC Inductive load DC	6A/250 VAC/1500 VA AC15 240VAC 2A 6A/24 VDC/150 W DC13 24VDC 1A
Max. res. load total switching capacity:	12A distributed on all contacts
Min. load	10mA/10 V(if load on contact has not exceeded 100 mA)
Contact material	Ag + Au flash
Fuses Output (External)	5A gL/gG
Conditional short-circuit current (1 kA)	6A gG
Max Input Wire res. at nom. voltage	200 Ohms
Response time at deactivation (input - output)	Version B <20 ms or delayed max 1500 ms (old version of BT50 <60 ms)

Terminals (Max. screw torque 1 Nm) Single strand: Conductor with socket contact:	2x1.5 mm ² 2x1mm ² .
Mounting	35 mm DIN-rail
Protection class enclosure/terminals	IP 40/20 IEC 60529
Impulse Withstand Voltage	2.5kV
Pollution Degree	2
Operating temperature range	-10°C to +55°C (with no icing or condensation)
Operating humidity range	35% to 85%
LED indication	Electrical Supply, Relay and X4
Weight	200 g
Performance (max.) Functional test: The relays must be cycled at least once a year.	Category 4/PL e (EN ISO 13849-1:2008) SIL 3 (EN 62061:2005) PFH _d 1.22E-08
Conformity	2006/42/EC, 2006/95/EC, 2004/108/EC EN 954-1:1996, EN 62061:2005 EN ISO 13849-1:2008

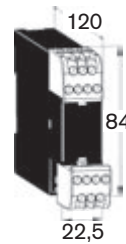

Connector blocks are detachable (without cables having to be disconnected)

Technical description – BT50(T)

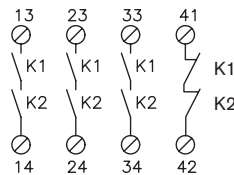
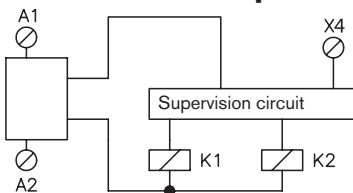

When supply voltage is connected to A1 and A2, relays K1 and K2 are activated. K1 and K2 drop if the supply voltage is disconnected. Both relays K1 and K2 must drop for them to be activated again. Another requirement is that the test circuit, A1 - X4, must be closed for the outputs to be activated. Thereafter A1 - X4 can either be open or constantly closed.

The supervising circuit ensures that both K1 and K2 have dropped before they can be reactivated. The stop function complies with the requirement that a component fault

or external interference cannot lead to a dangerous function.

The safety outputs consist of contacts from K1 and K2 connected internally in series across terminals 13 - 14, 23 - 24, and 33 - 34. These contacts are used to cut the power to components which stop or prevent hazardous movements/functions. It is recommended that all switched loads are adequately suppressed and/or fused in order to provide additional protection for the safety contacts.

The NC output 41 - 42 should only be used for monitoring purposes e.g. indication lamp for emergency stop pressed.

BT50T - Info. output

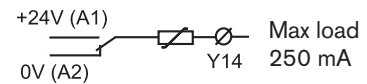

BT50T - Delay times

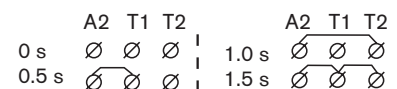

Electrical connection – BT50(T)

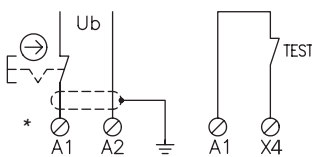

Emergency stop with reset when emergency button returns.

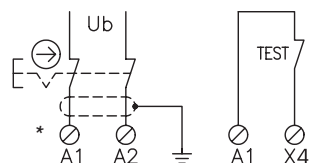

Emergency stop with dual connection direct to the supply voltage.

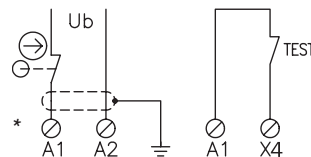

Hatch with automatic reset.

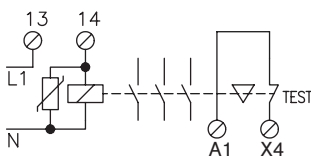

Controlled monitoring of external contactor, relay, valve or ABB Jokab Safety's expansion relays.

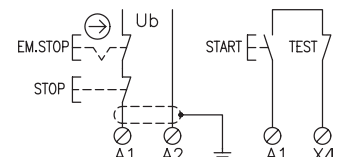

BT50 as emergency stop and control relay with Start and Stop function.

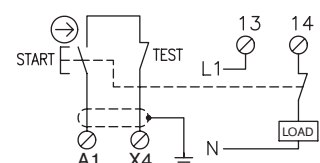

Monitoring to ensure that the On button is not stuck in pressed position. A short circuit over the closing contact is not monitored.

* BT50 has additional power terminals A1 and A2.

Safety relay/expansion relay

BT51(T)

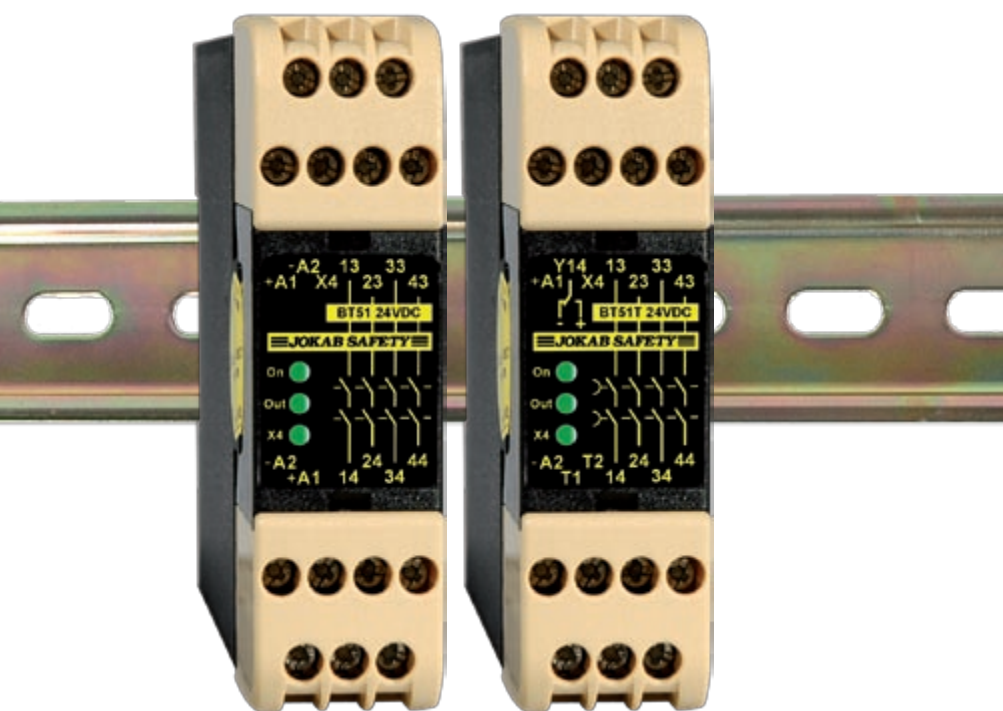

Safety relay/expansion relay to Pluto

The BT51 is designed to connect safety devices, such as emergency stops, directly in the voltage supply circuit to the relay. Despite a maximum built-in width of 22.5 mm the relay is very powerful.

With 4 NO safety outputs, test input and complete internal supervising, the BT51 is quite unique. In addition you can order delayed outputs (BT51T).

In order for the safety outputs to close, the supply voltage, e.g. by means of an emergency stop button, must be connected to A1 and A2 and the test input closed. After actuation of the relay the test input can be opened again.

The test input is intended to supervise that contactors or valves have dropped/returned before a new start can be permitted. The test input can also be used for starting and the start button can be supervised (see connection example on next page).

More outputs

By connecting BT51 to a safety relay/PLC it is easy to increase the number of safe outputs. This means that an unlimited number of dangerous machine operations and functions can be stopped from one safety relay/PLC.

Safety level

BT50 have an internal redundant and monitored safety function. Power failure, internal component faults or external interference cannot result in dangerous functions.

Input via A1 only is not protected from short circuiting, and therefore installation is critical for the safety level to be achieved. To achieve a higher safety level a screened cable can be used and/or connection made to both A1 and A2 (see example overleaf).

Approvals:



Safety relay for:

Emergency stop
Interlocked hatch
Expansion of Pluto

Features:

Single and "dual" channel
Test/"reset" input
Width 22.5 mm
LED indication
4 NO relay outputs
Supply 24 VDC
Quick release connector blocks
BT51 - Additional power terminals
BT51T - One changeover relay with a double information output (Y14)
BT51T
Delay times selectable from 0 - 1.5 s

Regulations and standards

The BT51 is designed and approved in accordance with appropriate directives and standards. See technical data.

Connection examples

For examples of how our safety relays can solve various safety problems, please see the chapter "Connection examples".

Technical data – BT51(T)

Manufacturer	ABB AB/Jokab Safety, Sweden
Article number/Ordering data BT51 BT51T	2TLJ010033R2000 2TLJ010033R3000
Colour	Black and beige
Operational voltage	24 VDC + 15%/-25%
Power consumption	1,4 W/1,8 W
Relay Outputs	4 NO
Max. switching capacity Resistive load AC Inductive load AC Resistive load DC Inductive load DC	6A/250 VAC/1500 VA AC15 240VAC 2A 6A/24 VDC/150 W DC13 24VDC 1A
Max. res. load total switching capacity:	12 A distributed on all contacts
Min. load	10mA/10 V (if load on contact has not exceeded 100 mA)
Contact material	Ag + Au flash
Fuses Output (External)	5A gL/gG
Conditional short-circuit current (1 kA)	6A gG
Max Input Wire res. at nom. voltage	200 Ohms
Response time at deactivation	<20 ms or delayed max 1500 ms (BT51T)
Terminals (Max. screw torque 1 Nm) Single strand: Conductor with socket contact:	2x1.5 mm ² 2x1mm ²

Mounting	35 mm DIN-rail
Protection class enclosure/ terminals	IP 40/20 IEC 60529
Impulse Withstand Voltage	2.5kV
Pollution Degree	2
Operating temperature range	-10°C to +55°C (with no icing or condensation)
Operating humidity range	35% to 85%
LED indication	Electrical Supply, Relay and X4
Weight	200 g
Performance (max.) Functional test: The relays must be cycled at least once a year.	Category 4/PL e (EN ISO 13849-1:2008) SIL 3 (EN 62061:2005) PFH _d 1.63E-08
Conformity	2006/42/EC, 2006/95/EC, 2004/108/EC EN 954-1:1996, EN 62061:2005 EN ISO 13849-1:2008

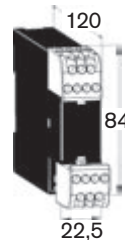

Connector blocks are detachable (without cables having to be disconnected)

Technical description – BT51(T)

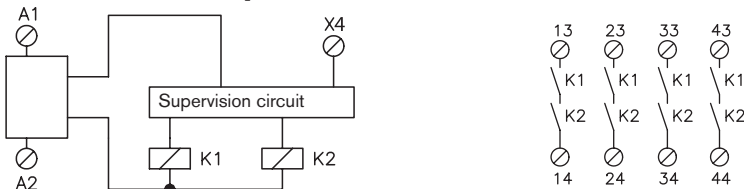

When supply voltage is connected to A1 and A2, relays K1 and K2 are activated. K1 and K2 drop if the supply voltage is disconnected. Both relays K1 and K2 must drop for them to be activated again. Another requirement is that the test circuit, A1 - X4, must be closed for the outputs to be activated. Thereafter A1 - X4 can either be open or constantly closed.

The supervising circuit ensures that both K1 and K2 have dropped before they can be reactivated. The stop function complies with the requirement that a component fault

or external interference cannot lead to a dangerous function.

The safety outputs consist of contacts from K1 and K2 connected internally in series across terminals 13 - 14, 23 - 24, 33 - 34 and 43 - 44. These contacts are used to cut the power to components which stop or prevent hazardous movements/functions. It is recommended that all switched loads are adequately suppressed and/or fused in order to provide additional protection for the safety contacts.

BT51T - Info. output

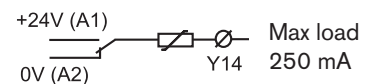

BT51T - Delay times

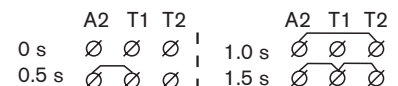

Electrical connection – BT51(T)

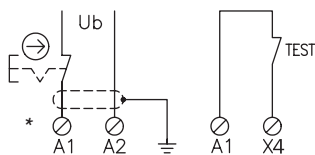

Emergency stop with reset when emergency button returns.

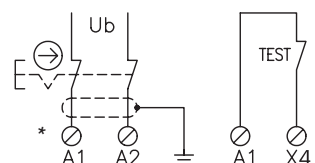

Emergency stop with dual connection direct to the supply voltage.

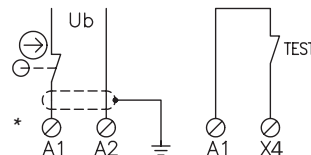

Hatch with automatic reset.

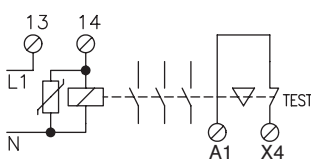

Controlled monitoring of external contactor, relay, valve or ABB Jokab Safety's expansion relays.

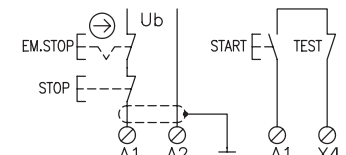

BT51 as emergency stop and control relay with Start and Stop function.

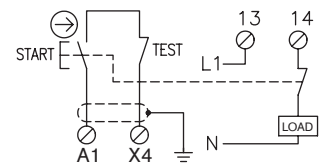

Monitoring to ensure that the On button is not stuck in pressed position. A short circuit over the closing contact is not monitored.

* BT51 has additional power terminals A1 and A2.

Safety relay

JSBT5(T)

Approvals:



Safety relay for:

Emergency stop
Interlocked hatch

Features:

Single and “dual” channel
Test/start input
Width 22.5 mm
LED indication
3 NO/1NC relay outputs
(T) = delayed outputs
0.5 sec.
Supply 12 VDC, 24 VDC/
AC

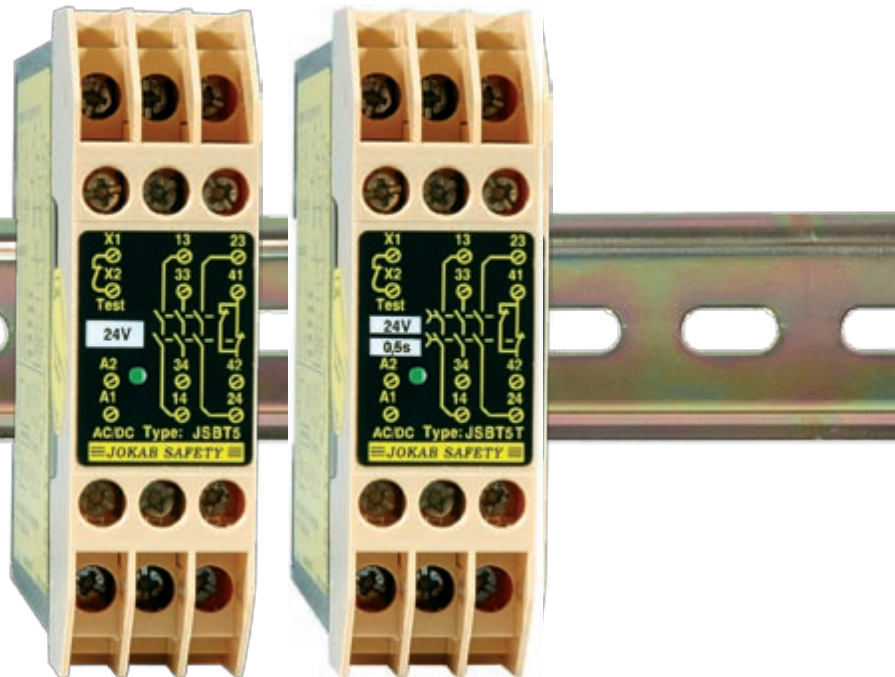

Single channel safety relay

The JSBT5 is designed to connect safety devices, such as emergency stops, directly in the voltage supply circuit to the relay. Despite a maximum built-in width of 22.5 mm the relay is very powerful.

With 3 NO safety outputs, 1 NC, test input and complete internal supervising, the JSBT5 is quite unique. In addition you can order delayed outputs (JSBT5T).

In order for the safety outputs to close, the supply voltage, e.g. by means of an emergency stop button, must be connected to A1 and A2 and the test input closed. After actuation of the relay the test input can be opened again.

The test input is intended to supervise that contactors or valves have dropped/returned before a new start can be permitted. The test input can also be used for starting and the start button can be supervised (see connection example on next page).

Safety level

The JSBT5 has a twin and supervised internal safety function. Power failure, internal component faults or external interference cannot result in dangerous functions.

Input via A1 only is not protected from short circuiting, and therefore installation is critical for the safety level to be achieved. To achieve a higher safety level a screened cable can be used and/or connection made to both A1 and A2 (see example overleaf).

Regulations and standards

The JSBT5 is designed and approved in accordance with appropriate directives and standards. See technical data.

Connection examples

For examples of how our safety relays can solve various safety problems, please see the section “Connection examples”.

Technical data – JSBT5(T)

Manufacturer	ABB AB/Jokab Safety, Sweden
Article number/Ordering data JSBT5 24 AC/DC JSBT5 12 VDC JSBT5T 24 AC/DC	2TLJ010005R0100 2TLJ010005R0700 2TLJ010005R1100
Colour	Black and beige
Operational voltage JSBT5: JSBT5T:	24 VDC/AC + 15%–25%, 50–60 Hz 12 VDC, 24 VDC/AC + 15% – 25%, 50 - 60 Hz
Power consumption	1 W/1,9 VA
Relay Outputs	3 NO + 1 NC
Max. switching capacity Resistive load AC Inductive load AC Resistive load DC Inductive load DC	6A/250 VAC/1500 VA AC15 240VAC 2A 6A/24 VDC/150 W DC13 24VDC 1A
Max. res. load total switching capacity:	9A distributed on all contacts
Min. load	10mA/10 V (if load on contact has not exceeded 100 mA)
Contact material	AgCuNi
Fuses Output (External)	5A gL/gG
Conditional short-circuit current (1 kA)	6A gG
Max Input Wire res. at nom. voltage	200 Ohm
Response time at deactivation	<60 ms or delayed max 500 ms (JSBT5T)

Terminals (Max. screw torque 1 Nm) Single strand: Conductor with socket contact:	2x1.5 mm ² 2x1mm ²
Mounting	35 mm DIN-rail
Protection class enclosure/ terminals	IP 40/20 IEC 60529
Impulse Withstand Voltage	2.5kV
Pollution Degree	2
Operating temperature range	-10°C to +55°C (with no icing or condensation)
Operating humidity range	35% to 85%
Function indication	Electrical Supply
Weight	200 g
Performance (max.) Functional test: The relays must be cycled at least once a year.	Category 4/PL e (EN ISO 13849-1:2008) SIL 3 (EN 62061:2005) PFH _d 1.22E-08
Conformity	2006/42/EC, 2006/95/EC, 2004/108/EC EN 954-1:1996, EN 62061:2005 EN ISO 13849-1:2008

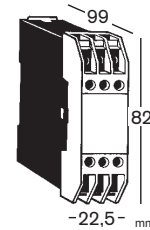

Technical description – JSBT5(T)



When supply voltage is connected to A1 and A2, relays K1 and K2 are activated. K1 and K2 drop if the supply voltage is disconnected. Both relays K1 and K2 must drop for them to be activated again. Another requirement is that the test circuit, X1 - X2, must be closed for the outputs to be activated. Thereafter X1 - X2 can either be open or constantly closed.

The supervising circuit ensures that both

K1 and K2 have dropped before they can be reactivated. The stop function complies with the requirement that a component fault or external interference cannot lead to a dangerous function.

The safety outputs consist of contacts from K1 and K2 connected internally in series across terminals 13 - 14, 23 - 24, and 33 - 34. These contacts are used to cut the power to components which stop

or prevent hazardous movements/functions. It is recommended that all switched loads are adequately suppressed and/or fused in order to provide additional protection for the safety contacts.

The NC output 41 - 42 should only be used for monitoring purposes e.g. indication lamp for emergency stop pressed.

Electrical connection – JSBT5(T)

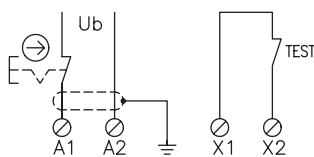

Emergency stop with automatic reset when emergency button returns.

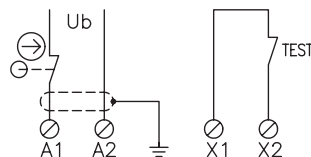

Hatch with automatic reset.

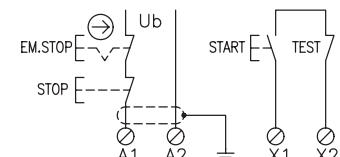

JSBT5 as emergency stop and control relay with Start and Stop function.

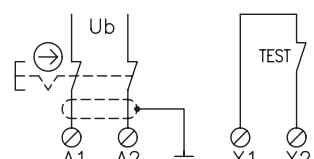

Emergency stop with dual connection direct to the supply voltage.

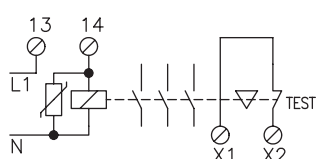

Controlled monitoring of external contactor, relay, valve or ABB Jokab Safety's expansion relays.

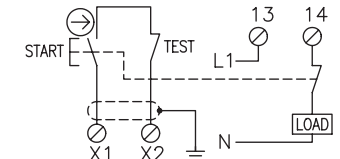

Monitoring to ensure that the On button is not stuck in pressed position. A short circuit over the closing contact is not monitored. The JSBR4 has built in short circuit monitored resetting.

Safety timer JSHT1

Approvals:



Safety timer for:

- Time reset
- Time bypassing

Features:

- Hardwire time selection
5 – 40 s
- Selectable single or dual channel input
- Test input
- Width 45 mm
- LED indication for supply, inputs and outputs
- 1+1 NO relay outputs
- Supply 24 VDC, 24, 48, 115 or 230 VAC
- Quick release connector blocks

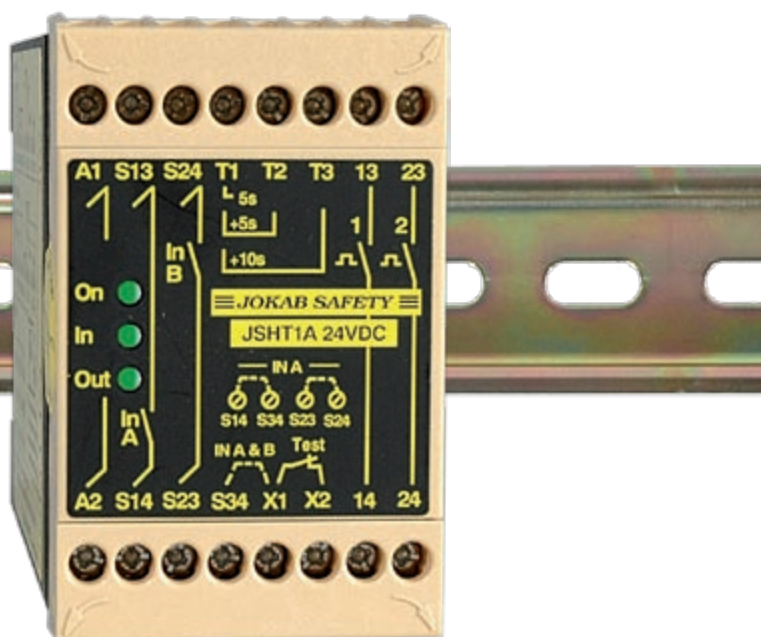

The JSHT1A/B closes two independent relay outputs during a guaranteed maximum time when the inputs are opened.

Time reset

Time reset can prevent unintentional reset of safety systems when someone is still in the dangerous area of the machine. During a guaranteed maximum time, one or several PB's for reset must be activated. The reset buttons should be sited in such a way that operatives have a clear overview of the whole area which is guarded. Time reset is made by the combination of a safety relay and the timer relay JSHT1A/B.

Time bypassing

The JSHT1 can also be used for time bypass of light beams for e.g. autotruck into a dangerous area.

Operation

When the inputs open the output contacts close. The output contacts open when the inputs close or when the time period has expired. The time period is hardwire selectable on terminals T1, T2 and T3. The time given is the maximum time. One or two channel operation is also hardwire selectable.

Regulations and standards

The JSHT1A/B is designed and approved in accordance with appropriate directives and standards. See technical data.

Connection examples

For examples of how our safety relays can solve various safety problems, please see the section "Connection examples".

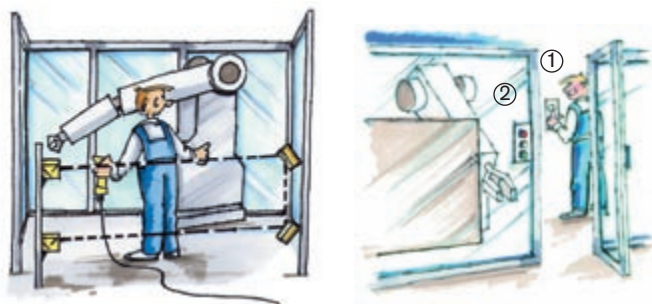

Light beam being bypassed for a maximum pre-set time e.g. 5 sec. by the JSHT1 during entrance and exit with the JSHD4 Three Position Enabling device.

Time reset procedure. First push PB1, then exit dangerous area and close the door, then push PB2 (PB1 and PB2 must be pressed within the predetermined time period selected). After this procedure the machine can be safely restarted.

Technical data – JSHT1 A/B

Manufacturer	ABB AB/Jokab Safety, Sweden
Article number/Ordering data JSHT1A 24 DC JSHT1B 24 DC	2TLJ010011R0000 2TLJ010011R1000
Colour	Black and beige
Power supply	24 VDC ± 15 %, 24/48/115/230 VAC ± 15 %, 50 - 60 Hz (AC versions JSHT1A only)
Power consumption	1,8 W/3,7 VA
Max Input Wire res. at nom voltage/channel	100/200 Ohm (1 Channel/ 2 Channel)
Response time at activation	<30ms
Response time at deactivation	< 15 ms
Selectable time (± 15 % at nom. V.)	JSHT1A: 5-10-15-20 sec JSHT1B: 5-15-30-40 sec
Relay outputs	2 x 1 NO
Max. switching capacity	
Resistive load AC	4A/250 VAC/1000 VA
Inductive load AC	AC15 250VAC 3A
Resistive load DC	4A/24 VDC/100 W
Inductive load DC	DC13 24VDC 2A
Max. total switching capacity:	8A distributed on all contacts
Min. load	10mA/10 V (if load on contact has not exceeded 100 mA)
Contact material	AgCuNi
Fuses Output (External)	3A gL/gG or 4A fast
Conditional short-circuit current (1 kA)	6A gG
Max Input Wire res. at nom. voltage	100 Ohm

Terminals (Max. screw torque 1 Nm)	Single strand: 1 x 4 mm ² , 2 x 1,5 mm ² Conductor with socket contact: 1 x 2,5 mm ² , 2 x 1 mm ²
Mounting	35 mm DIN-rail
Protection class enclosure/ terminals	IP20/IP40 IEC 60529
Impulse Withstand Voltage	2.5kV
Pollution Degree	2
Operating temperature range	-10°C to +55°C (with no icing or condensation)
Operating humidity range	35% to 85%
LED indication	Electrical Supply, Inputs, Outputs
Weight	24 VDC: 330 g 24/48/115/230 VAC: 430 g
Performance (max.)	Category 4 / PL e (EN ISO 13849-1:2008) Functional test: The relays must be cycled at least once a year.
Conformity	2006/42/EC, 2006/95/EC, 2004/108/EC EN 954-1:1996, EN 62061:2005 EN ISO 13849-1:2008

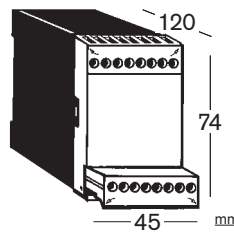

Connector blocks are detachable (without cables having to be disconnected)

Technical description – JSHT1 A/B

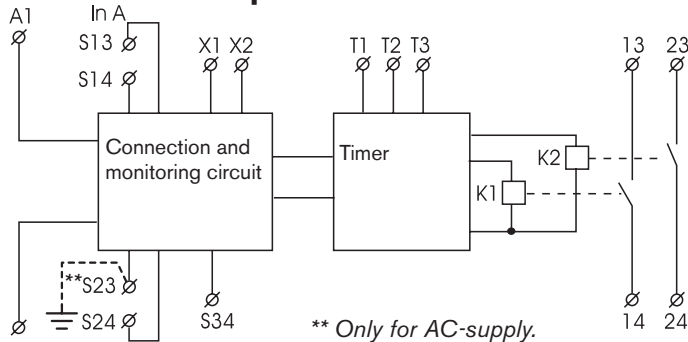

The electrical supply is connected across A1 and A2. The internal supervising circuit is activated directly when the supply is on. The inputs A and B must both be closed and then opened. Thereafter K1 and K2

are activated and the outputs close. K1 and K2 are activated for the hardwired selected time (set by connections on the terminals T1, T2 and T3). If there is a short circuit between the inputs or the inputs

are closed again before the set time period has expired the outputs will open. In order to close the outputs again both the inputs have to be closed and both internal relays K1 and K2 deactivated (controlled by the supervising circuit) and the inputs again opened.

By external hardwire connections the JSHT1 can be made single or dual channel input. See figure below.

Electrical connection – JSHT1 A/B

Connection for single channel input

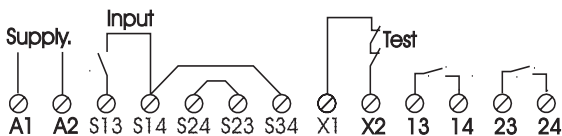

Selection of time by hardwire links

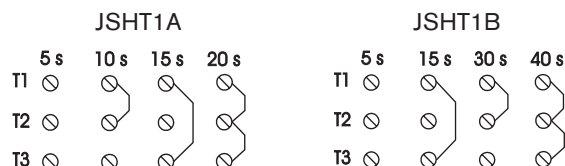

Connection for dual channel input

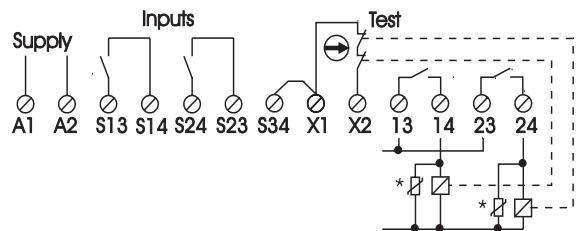

* It is recommended that all switched loads are adequately suppressed and/or fused in order to provide additional protection for the safety contacts. In the figure the monitoring of two contactors in the test input is shown.

Safety timer

JSHT2

Approvals:



Safety relay for:

Time bypassing
Inching

Features:

- Hardwire time selection
0.2 – 40 s
- Selectable single or dual channel input
- Test input
- Width 45 mm
- LED indication for supply, inputs and outputs
- 1+1 NO relay outputs
- Supply 24 VDC, 24, 48, 115 or 230 VAC
- Quick release connector blocks

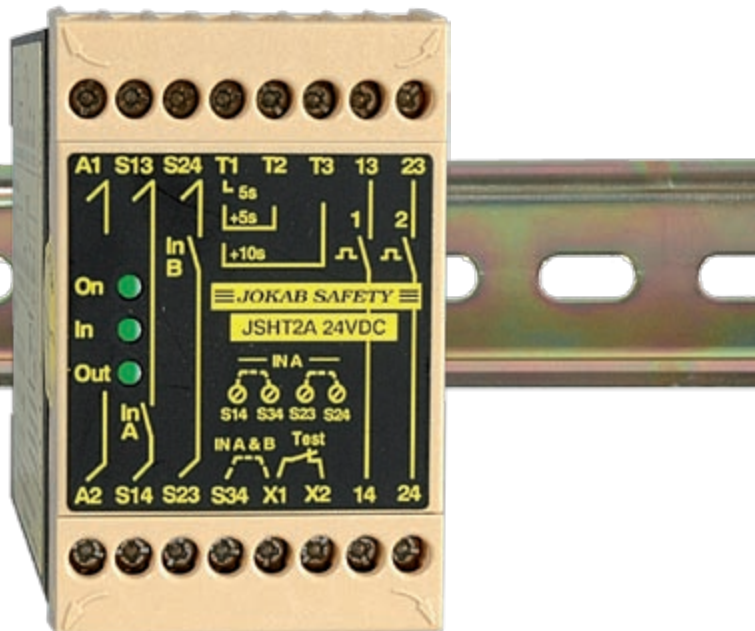

The JSHT2A/B/C closes two independent relay outputs during a guaranteed maximum period of time when the inputs are closed.

Time bypassing

Sensors detect the autocarrier and are connected to the JSHT2 which supervises the sensors and bypasses the light beam for a maximum predetermined time.

Inching

Inching applications require safety outputs to be closed for a predetermined maximum period of time, allowing the machine to move only a short distance each time the inching control is activated. For each new motion the inching control e.g. PB or pedal must be released and activated again.

Operation

When the inputs close the output contacts close. The output contacts open when the input opens or when the time period has expired. The time is hardwire selectable on the terminals T1, T2 and T3. The time given is the maximum time. Single or dual channel operation is also hardwire selectable.

Regulations and standards

The JSHT2A/B/C is designed and approved in accordance with appropriate directives and standards. See technical data.

Connection examples

For examples of how our safety relays can solve various safety problems, please see the section "Connection examples".

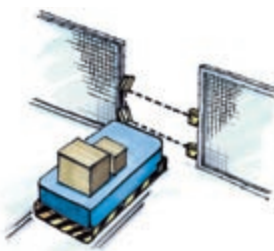

Light beam being bypassed only for the time it takes the autocarrier to pass.



Shaft only turns a small amount each time the PB is pressed.

Technical data – JSHT2 A/B/C	
Manufacturer	ABB AB/Jokab Safety, Sweden
Article number/Ordering data	JSHT2A 24 DC 2TLJ010012R0000 JSHT2B 24 DC 2TLJ010012R1000 JSHT2C 24 DC 2TLJ010012R2000
Colour	Black and beige
Power supply	24 VDC ± 15 % 24/48/115/230 VAC ± 15 %, 50 - 60 HZ
Power consumption	1,8 W/3,8 VA
Max Input Wire res. at nom voltage/channel	100/200 Ohm (1 Channel/ 2 Channel)
Response time at activation	< 30 ms
Response time at deactivation	< 15 ms
Selectable time (± 15 % at nom. V.)	JSHT2A: 0.2 - 0.5 - 0.7 - 1.0 sec JSHT2B: 5 - 10 - 15 - 20 sec JSHT2C: 5 - 15 - 30 - 40 sec
Relay outputs	2 x 1 NO
Max. switching capacity	
Resistive load AC	4A/250 VAC/1000 VA
Inductive load AC	AC15 250VAC 3A
Resistive load DC	4A/24 VDC/100 W
Inductive load DC	DC13 24VDC 2A
Max. total switching capacity:	8A distributed on all contacts
Min. load	10mA/10 V (if load on contact has not exceeded 100 mA)
Contact material	AgCuNi
Fuses Output (External)	3A gL/gG or 4A fast
Max Input Wire res. at nom. voltage	100 Ohm

Terminals (Max. screw torque 1 Nm)	Single strand: 1 x 4 mm ² or 2 x 1,5 mm ² Conductor with socket contact: 1 x 2,5 mm ² or 2 x 1 mm ²
Mounting	35 mm DIN-rail
Protection class enclosure/terminals	IP 20/IP 40 IEC 60529
Impulse Withstand Voltage	2.5kV
Pollution Degree	2
Operating temperature range	-10°C to +55°C (with no icing or condensation)
Operating humidity range	35% to 85%
LED indication	Electrical Supply, Inputs, Outputs
Weight	24 VDC: 310 g 24/48/115/230 VAC: 410 g.
Performance (max.)	Safety Category 4/PL e (EN ISO 13849-1:2008) SIL 3 (EN 62061:2005) PFH _d 4.42E-09
Conformity	2006/42/EC, 2006/95/EC, 2004/108/EC EN 954-1:1996, EN 62061:2005 EN ISO 13849-1:2008

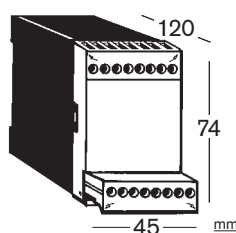

Connector blocks are detachable (without cables having to be disconnected)

Technical description – JSHT2 A/B/C

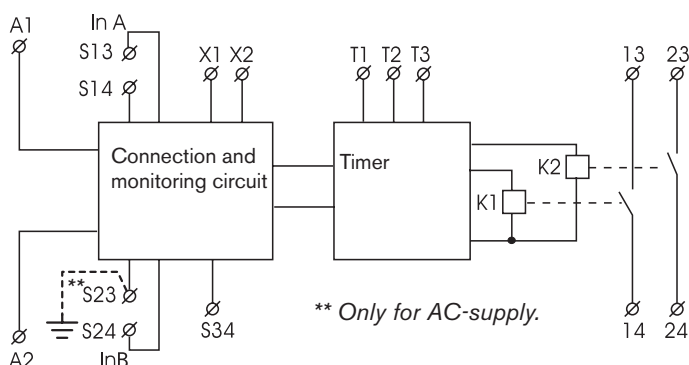

The electrical supply is connected across A1 and A2. The internal supervising circuit is activated directly when the supply is on. The inputs A and B must both be opened and then closed. Thereafter K1 and K2 are activated and the outputs close. K1 and K2 are activated for hardwired selected time

(set by connections on the terminals T1, T2 and T3). If there is a short circuit between the inputs or the inputs are opened again before the set time period has expired the outputs will open. In order to close the outputs again both the inputs have to be opened and both internal relays K1 and

K2 deactivated (controlled by the supervising circuit) and then the inputs closed again.

By external hardwire connectors the JSHT2 can be made to operate from either single or dual channel inputs. See figure below.

Electrical connection – JSHT2 A/B/C

Connection for single channel input

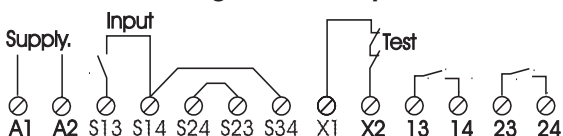

Connection for dual channel input

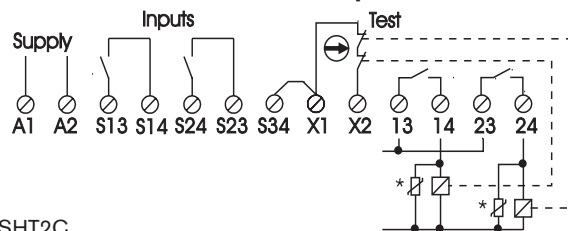

Selection of time by hardwire links

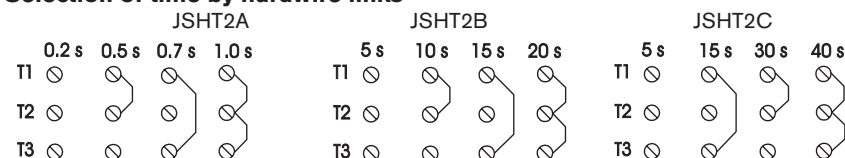

* It is recommended that all switched loads are adequately suppressed and/or fused in order to provide additional protection for the safety contacts. In the figure the monitoring of two contactors in the test input is shown.

Expansion relay

E1T

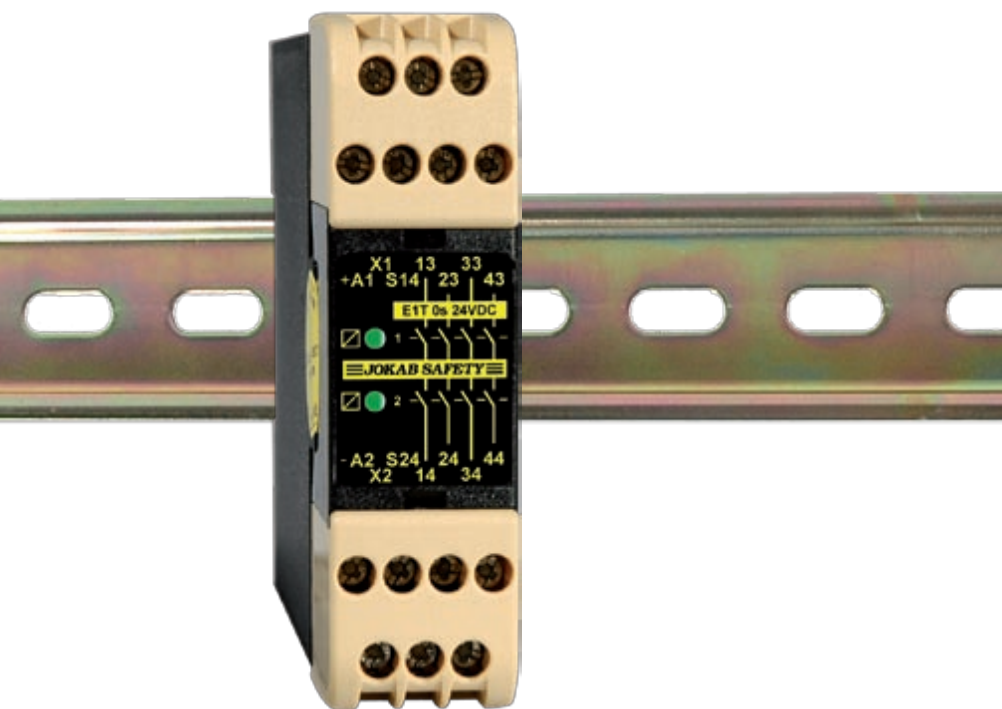

Approvals:



Expansion relay with:

- More safety outputs
- Delayed safety outputs

Features:

- Width 22.5 mm
- Supply 24 VDC
- LED output indication
- 4 NO relay outputs
- Single or dual channel operation option
- Quick release connector blocks

More outputs

By connecting expansion relays to a safety relay it is easy to increase the number of safe outputs. This means that an unlimited number of dangerous machine operations and functions can be stopped from one safety relay.

Safe soft stop

When a gate is opened a program stop is first given to the machine's PLC/servo which brakes the dangerous operations in a soft and controlled way. The safety outputs then break the power to the motors, that is, when the machine has already stopped. Normally between 0.5 and 1 second is needed to brake a dangerous machine operation softly.

Soft stop ensures many advantages:

- The machine lasts longer.
- Parts being processed are not damaged.
- Restart from stopped position is enabled and simplified.

A safe soft stop is achieved by means of a safety relay which gives the program stop, and an expansion relay, E1T, which gives safe delayed stop signals. See section "Connection examples". The drop time delay on a E1T can as standard be selected from 0 to 3 seconds. By connecting several E1T's in series even longer times can be achieved.

When are delayed safe stops used?

Delayed safety stop signals can be used for emergency stops according to EN ISO 13850:2008 § 4.1.4. Stop category 1, i.e. a controlled stop with power to the actuator(s) available to achieve the stop and then removal of power when stop is achieved.

Stop category 1 may also be permitted when it is not possible to gain physical access to the machine before the safe stop is affected e.g:

- Gates, access time is normally over 1 sec.
- Covers and gates which are locked until dangerous operations and functions have been stopped.
- Long distances between a safety device and a dangerous machine function.

Safety level

The E1T has twin stop functions, that is, two relays with mechanically operated contacts. A monitored stop function is achieved by connecting the test output (terminals X1 and X2) to the test or reset input on the safety relay which is being expanded.

One condition for a safe delayed stop is that the delay time cannot increase in the event of a fault. The E1T complies with this requirement.

Regulations and standards

The E1T is designed and approved in accordance with appropriate directives and standards. See technical data.

Connection examples

For examples of how our safety relays can solve various safety problems, please see the section "Connection examples".

Technical data – E1T

Manufacturer	ABB AB/Jokab Safety, Sweden
Article number/Ordering data	E1T 0 s 24DC 2TLJ010030R000 E1T 0,5 s 24DC 2TLJ010030R1000 E1T 1 s 24DC 2TLJ010030R2000 E1T 1,5 s 24DC 2TLJ010030R3000 E1T 2 s 24DC 2TLJ010030R4000 E1T 3 s 24DC 2TLJ010030R5000
Colour	Black and beige
Operational voltage	24 VDC ± 15%
Power consumption	1,5 W
Relay Outputs	4 NO
Max. switching capacity	Resistive load AC 6A/250VAC/1500VA Inductive load AC AC15 240VAC 2A Resistive load DC 6A/24VDC/150W Inductive load DC DC13 24VDC 1A
Max. total switching capacity	12A distributed on all contacts
Min. switching load	10 mA/10 V (if load on contact has not exceeded 100 mA)
Contact material	Ag + Au flash
Fuses Output (External)	5A gL/gG
Conditional short-circuit current (1 kA)	6A gG
Maximum external resistance at a nominal voltage	150 Ohm (S14, S24)
Response time at deactivation (input - output)	< 0,020 s, 0,5 s, 1 s, 1,5 s, 2 s, 3 s, ± 20%

Response time at activation (input-output)	<30 ms
Terminals (Max. screw torque 1 Nm)	Single strand: 1x4 mm ² /2x1,5 mm ² Conductor with socket contact: 1x2,5 mm ² /2x1 mm ² .
Mounting	35 mm DIN-rail
Protection class	enclosure IP 40 IEC 60529 terminals IP 20 IEC 60529
Impulse Withstand Voltage	2.5kV
Pollution Degree	2
Operating temperature range	-10°C – +55°C (with no icing or condensation)
Operating humidity range	35% to 85%
LED indication	Output status
Weight	220 g
Performance (max.)	Category 4/PL e Functional test: The relays must be cycled at least once a year. (EN ISO 13849-1:2008) SIL 3 (EN 62061:2005) PFH _d 1.55E-08
Conformity	2006/42/EC, 2006/95/EC, 2004/108/EC EN 954-1:1996, EN 62061:2005 EN ISO 13849-1:2008

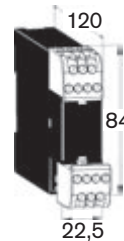

Connector blocks are detachable (without cables having to be disconnected)

Technical description – E1T

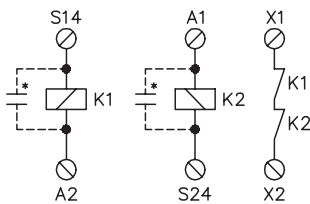

The E1T has to be connected to a safety relay in order to fulfill the necessary safety requirements (see connection examples below). The safety relay controls and monitors the E1T (The E1T can be connected for single or dual channel operation - see below). When the inputs S14 and S24

close, relays K1 and K2 are activated. A stop signal is given, K1 and K2 drop, if the inputs are opened or during power failure. K1 and K2 drop either directly or after a delay* (if incorporated). Delay time of module is fixed and shown on front panel of device. The delay circuit is so arranged that the design time cannot be exceeded.

To check that both the relays K1 and K2

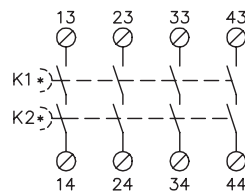

drop during a stop signal they must be monitored. This is achieved by connecting X1 and X2 to the test or reset input on the safety relay which is expanded (see below). K1 and K2 are mechanically operated relays, therefore, if one of the output contacts in X1-X2 cannot be closed thus preventing a new ready signal being given to the safety relay.

Inductive loads should be equipped with an arc suppressor to protect the output contacts.

Diodes are the best arc suppressors but will increase the switch off time of the load.

Electrical connection – E1T

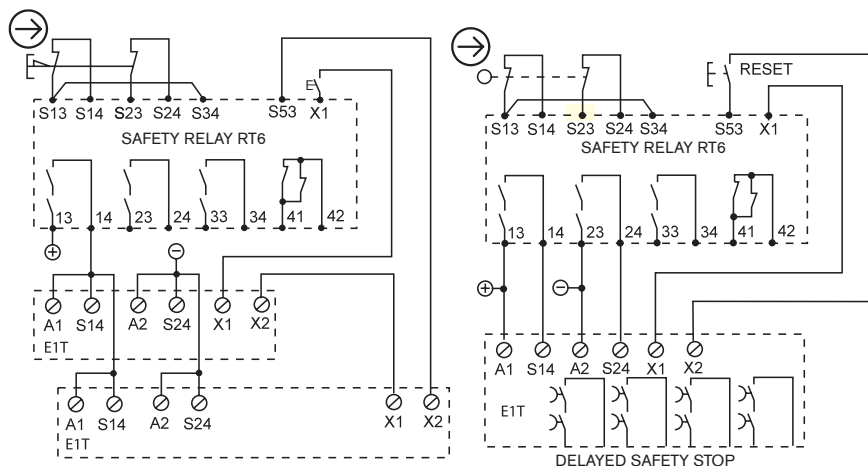

Single channel expansion of outputs for a safety relay connected to an emergency stop. Dual channel expansion with delayed safety outputs for a safety relay monitoring a gate.

Expansion relay

JSR1T

Approvals:



Expansion relay with:

- More safe outputs
- Delayed safe outputs
- Information output

Features:

- Width 45 mm
- Supply 24 VDC
- LED function indication
- 4 NO/1 NC relay outputs
- Single and dual channel
- Quick release connector blocks

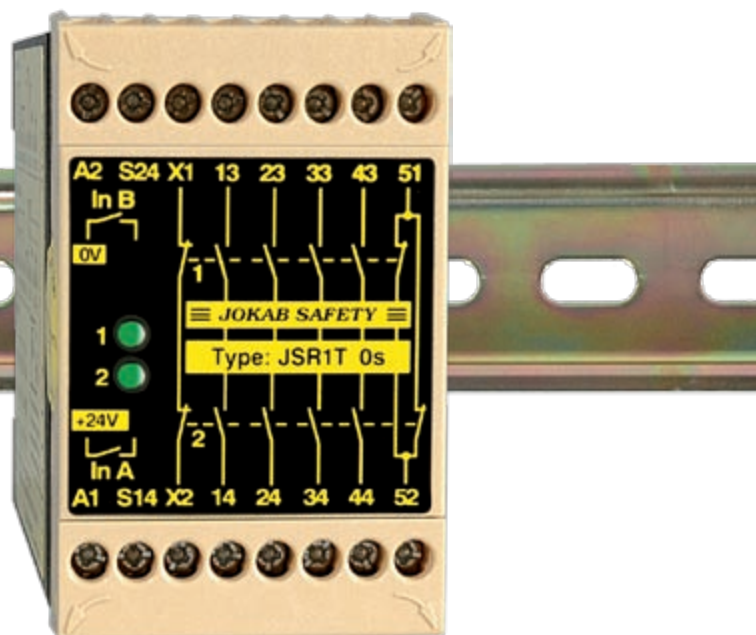

More outputs

By connecting expansion relays to a safety relay it is easy to increase the number of safe outputs. This means that an unlimited number of dangerous machine operations and functions can be stopped from one safety relay.

Safe soft stop

When a gate is opened a program stop is first given to the machine's PLC/servo which brakes the dangerous operations in a soft and controlled way. The safety outputs then break the power to the motors, that is, when the machine has already stopped. Normally between 0.5 and 1 second is needed to brake a dangerous machine operation softly.

Soft stop ensures many advantages:

- The machine lasts longer.
- Parts being processed are not damaged.
- Restart from stopped position is enabled and simplified.

A safe soft stop is achieved by means of a safety relay which gives the program stop, and an expansion relay, JSR1T, which gives safe delayed stop signals. See section "Connection examples". The drop time delay on a JSR1T can as standard be selected from 0 to 10 seconds. By connecting several JSR1T's in series even longer times can be achieved.

When are delayed safe stops used?

Delayed safety stop signals can be used for emergency stops according to EN418 § 4.1.4 Stop category 1, i.e. a controlled stop with power to the actuator(s) available to achieve the stop and then removal of power when stop is achieved.

Stop category 1 may also be permitted when it is not possible to gain physical access to the machine before the safe stop is affected e.g:

- Gates, access time is normally over 1 sec.
- Covers and gates which are locked until dangerous operations and functions have been stopped.
- Long distances between a safety device and a dangerous machine function.

Safety level

The JSR1T has twin stop functions, that is, two relays with mechanically operated contacts. A monitored stop function is achieved by connecting the test output (terminals X1 and X2) to the test or reset input on the safety relay which is being expanded.

One condition for a safe delayed stop is that the delay time cannot increase in the event of a fault. The JSR1T complies with this requirement.

Regulations and standards

The JSR1T is designed and approved in accordance with appropriate directives and standards. See technical data.

Connection examples

For examples of how our safety relays can solve various safety problems, please see the section "Connection examples".

Technical data – JSR1T

Manufacturer	ABB AB/Jokab Safety, Sweden
Article number/Ordering data	
JSR1T 0	6 A 24 DC
JSR1T 1,5	6 A 24 DC
JSR1T 8	6 A 24 DC
JSR1T 0,5	6 A 24 D
JSR1T 10s	6 A 24 DC
JSR1T 1	6 A 24 DC
JSR1T 2	6 A 24 DC
JSR1T 3	6 A 24 DC
JSR1T 5	6 A 24 DC
	2TLJ010015R0000
	2TLJ010015R0500
	2TLJ010015R0600
	2TLJ010015R1000
	2TLJ010015R2000
	2TLJ010015R3000
	2TLJ010015R4000
	2TLJ010015R5000
	2TLJ010015R6000
Colour	Black and beige
Power supply	24 VDC ±15%
Power consumption	1,2 W
Relay Outputs	4 NO + 1 NC
Max. switching capacity	
Resistive load AC	6A/250 VAC/1500 VA
Inductive load AC	AC15 240VAC 2A
Resistive load DC	6A/24 VDC/150 W
Inductive load DC	DC13 24VDC 1A
Max. total switching capacity:	16A distributed on all contacts
Min. load	10mA/10 V (if load on contact has not exceeded 100 mA)
Contact material	Ag + Au flash
Fuses Output (External)	5A gL/gG
Conditional short-circuit current (1 kA)	6A gG
Max. Input wire res. at nom. voltage	150 Ohm (S14, S24)
Response time at deactivation (input-output)	< 0,020 s, 0,5 s, 1 s, 1,5 s, 2 s, 3 s, 5 s, 8 s, 10 s ± 20 %

Terminals (Max. screw torque 1 Nm)	
Single strand:	1 x 2,5 mm ² /2 x 1mm ²
Conductor with socket contact:	1 x 4 mm ² /2 x 1,5 mm ²
Mounting	35 mm DIN-rail
Protection class enclosure/terminals	IP 40/20 IEC 60529
Impulse Withstand Voltage	2.5kV
Pollution Degree	2
Operating temperature range	-10°C to +55°C (with no icing or condensation)
Operating humidity range	35% to 85%
LED indication	Output Relay Supplies
Weight	280 g
Performance (max.)	Category 4/PL e (EN ISO 13849-1:2008) SIL 3 (EN 62061:2005) PFH _d 1.55E-08 Functional test: The relays must be cycled at least once a year
Conformity	2006/42/EC, 2006/95/EC, 2004/108/EC EN 954-1:1996, EN 62061:2005 EN ISO 13849-1:2008

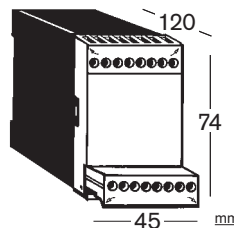

Connector blocks are detachable (without cables having to be disconnected)

Technical description – JSR1T

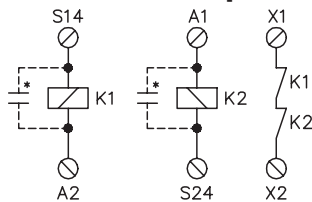

The JSR1T has to be connected to a safety relay in order to fulfill the necessary safety requirements (see connection examples below). The safety relay controls and monitors the JSR1T. (The JSR1T can be connected for single or dual channel operation - see below). When the inputs S14 and S24 close, relays K1 and K2 are activated. A stop

signal is given, K1 and K2 drop, if the inputs are opened or during power failure. K1 and K2 drop either directly or after a delay* (If incorporated). Delay time of module is fixed and shown on front panel of device. The delay circuit is so arranged that the design time cannot be exceeded.

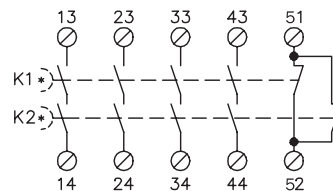

To check that both the relays K1 and K2 drop during a stop signal they must be monitored. This is achieved by connecting X1 and X2 to the test or reset input on the safety relay which is expanded (see below). K1 and K2 are mechanically operated relays, therefore, if one of the output contacts should stick closed then the relay's contact in X1-X2 cannot be closed thus preventing a new ready signal being given to the safety relay.

Inductive loads should be equipped with an arc suppressor to protect the output contacts.

Diodes are the best arc suppressors but will increase the switch off time of the load.

Electrical connection – JSR1T

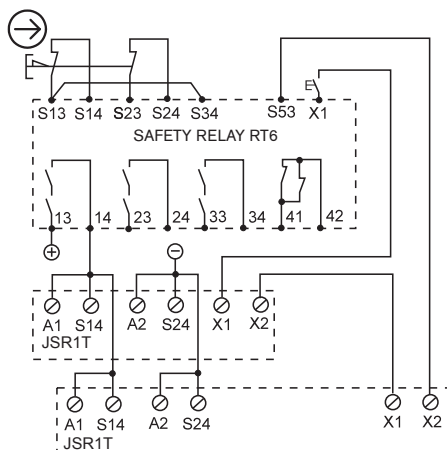

Expansion of outputs for safety relay connected to emergency stop with automatic reset.

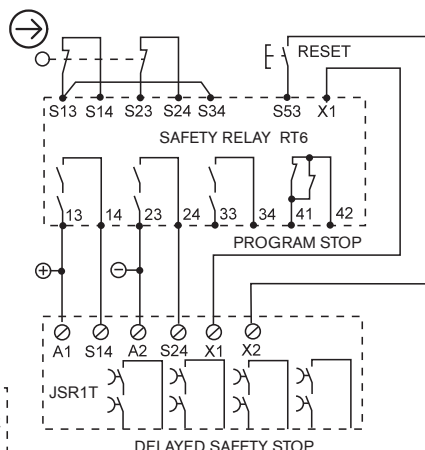

Dual-channel expansion with delayed safety outputs for safety relay monitoring a gate.

Expansion relay

JSR2A

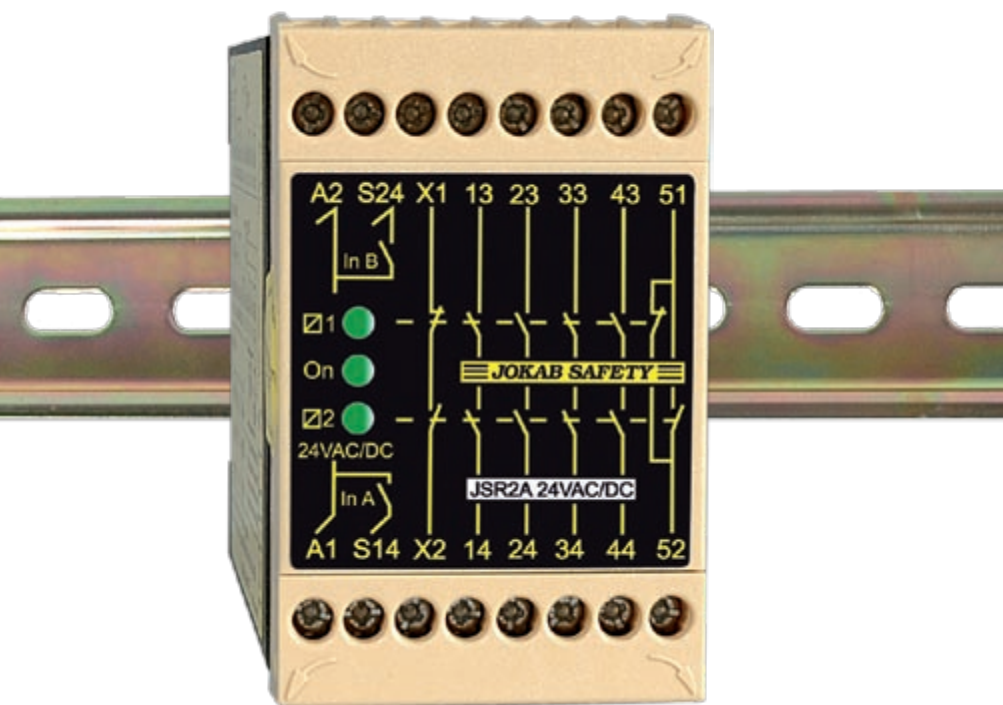

More outputs

The JSR2A expansion relay is used to provide increased switching capacity and number of safety outputs to a safety relay. This means that an unlimited number of dangerous machine operations and functions can be stopped from one safety relay.

Greater current switching capacity

The JSR2A Expansion relay enables switching of up to 10 amps (AC/DC) per output contact.

Safety level

The JSR2A has twin stop functions, that is, two relays with mechanically positively guided contacts. A monitored stop function is achieved by connecting the test output (terminals X1 and X2) to the test or reset input on the safety relay which is to be expanded.

Regulations and standards

The JSR2A is designed and approved in accordance with appropriate directives and standards. See technical data.

Connection examples

For examples of how our safety relays can solve various safety problems, please see the section "Connection examples".

Approvals:

TÜV Nord  

Expansion relay with:

- More safe outputs
- Greater current switching capacity
- Information output

Features:

- Switching capacity of up to 10 A/250V per output
- Width 45 mm
- LED function indication
- 4 NO/1 NC relay outputs
- 5 supply versions
- Supply 24 VDC/VAC, 48 VAC, 115 and 230 VAC
- Quick release connector blocks

Technical data – JSR2A

Manufacturer	ABB AB/Jokab Safety, Sweden
Article number/Ordering data	JSR2A 10 A 24 AC/DC JSR2A 10 A 115 AC JSR2A 10 A 230 AC
	2TLJ010027R0100 2TLJ010027R0400 2TLJ010027R0500
Colour	Black and beige
Supply A1 - A2	24 VDC/AC, 48, 115, 230 VAC + 15%, 50-60 Hz
Power consumption	2,7W/2,4-4 VA
Relay Outputs	4 NO + 1 NC
Max. switching capacity	
Resistive load AC	8A/230 VAC/1840 VA 10A/115VAC/48VAC/24VAC/ 1840 VA
Inductive load AC	AC15 230VAC 4A (NO-contact) 1.5A (NC-contact)
Resistive load DC	8A/24 VDC/192 W
Inductive load DC	DC13 24VDC 1.2A (NO/NC-contact)
Max. total switching capacity:	16A distributed on all contacts
Min. load	10mA/10V/100mW (if load on contact has not exceeded 100 mA)
Contact material	AgSnO ₂ + Au flash
Fuses Output (External)	6A gL (8A fast if short-circuit current >500A)
Conditional short-circuit current (1 kA)	10A gG
Max. Input wire res. at nom. voltage	24 VDC/VAC: 100 Ohm 48/115/230 VAC: 200 Ohm
Mechanical operational Life	>10 ⁷ operations
Response time at	
deactivation (input- output)	<25 ms
activation (input - output):	<15 ms
Terminals (removable)	
Max. screw torque	1 Nm

Connection Area (max.)	
Single strand	1 x 4 mm ² or 2 x 1.5 mm ² /12AWG
Conductor with socket contact	1 x 2.5 mm ² or 2 x 1 mm ²
Mounting	35 mm DIN-rail
Protection class terminals	
Enclosure	IP 40 IEC 60529
Terminals	IP 20 IEC 60529
LED indication	
On	Supply voltage
	Output relays 1 and 2
Impulse Withstand Voltage	2.5kV
Pollution Degree	2
Operating temperature range	-10°C to +55°C (with no icing or condensation)
Operating humidity range	35% to 85%
Weight	313 g
Performance (max.)	
Functional test: The relays must be cycled at least once a year	Category 4/PL e (EN ISO 13849-1:2008) SIL 3 (EN 62061:2005) PFH _d 1.55E-08
Conformity	2006/42/EC, 2006/95/EC, 2004/108/EC EN 954-1:1996, EN 62061:2005 EN ISO 13849-1:2008

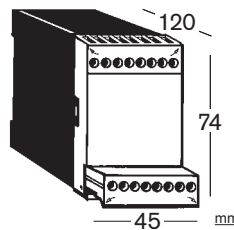

Connector blocks are detachable
(without cables having to be disconnected)

Technical description – JSR2A

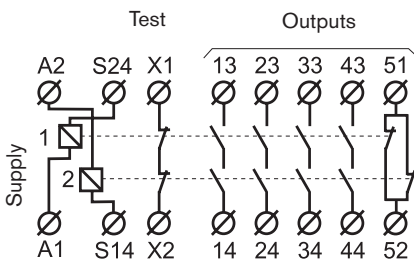

The JSR2A has to be connected to a suitable safety relay in order to fulfill the necessary safety requirements (see chapter "Connection examples"). The Safety Relay controls and monitors the JSR2A unit. (The JSR2A can be connected for single or dual channel operation - see Electrical connection diagrams below). When the inputs to S14 and S24 close, internal relays K1 and K2 are activated. A stop signal is given, K1 and K2 drop, if the inputs are opened or during power failure.

To check that both the K1 and K2 relays drop during a stop signal they must be monitored. This is achieved by connecting X1 and X2 to the test or reset input on the safety relay which is expanded. K1 and K2 have mechanically positively guided contacts, therefore, if one of the output contacts should stick closed then the relay's contact in X1-X2 cannot be closed thus preventing a new ready signal being given to the safety relay.

Electrical connection – JSR2A

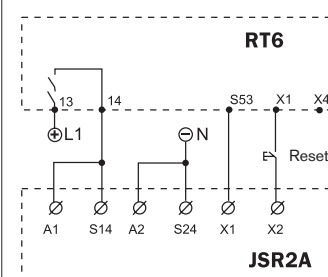

One channel expansion of RT6 with JSR2A connected for manual reset.

Dual channel expansion of RT6 with JSR2A connected for automatic reset.

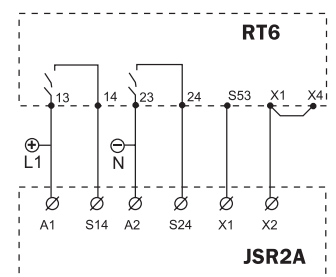

Expansion relay JSR3T

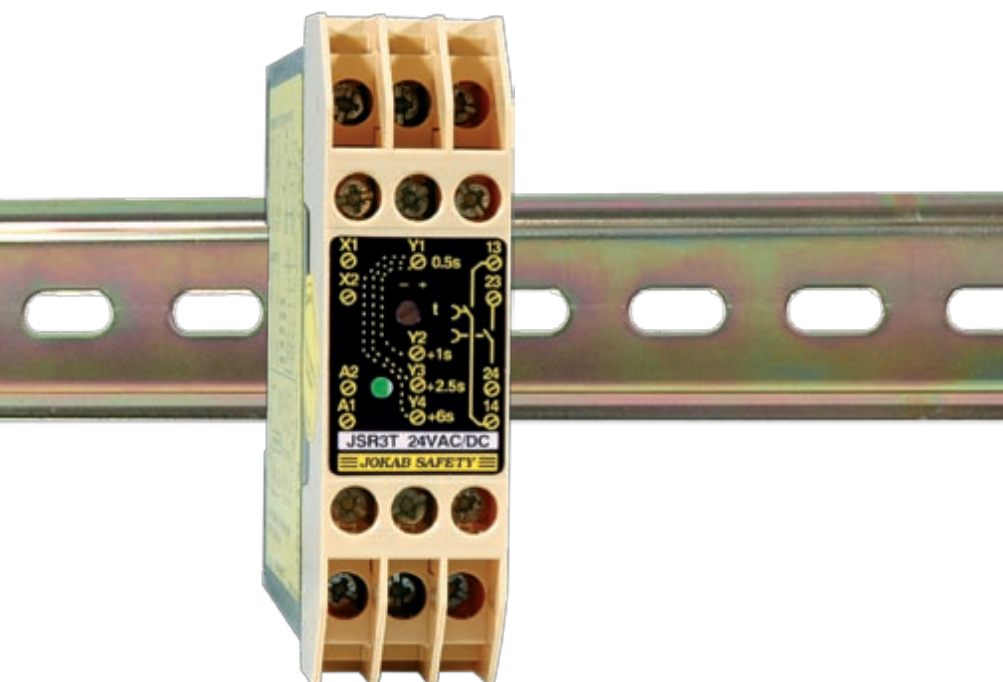

Approvals:



Expansion relay with delay with:

- Safe delay of stop signals with selectable value
- Delayed safe outputs

Features:

- Width 22.5 mm
- Supply 24V AC/DC
- Output indication
- 2 x 1 NO relay outputs
- Hardwire Selectable Delay 0.5 - 10.0 sec by hardwire links and Time trim potentiometer

Delayed outputs

By connecting the JSR3T expansion relay to a compatible Safety relay it is easy to obtain safe "delayed" outputs.

The JSR3T provides the system designer with the facility to hardwire selected time delays in steps between 0.5 and 10 seconds.

Use of delayed outputs

There are many applications where delayed outputs are necessary and permissible. For example delayed stop signals can be used for emergency stops according to EN ISO 13850:2008 § 4.1.4 Stop Category 1 (a controlled stop with power to the machine actuator(s) available to achieve the stop and then removal of power when stop is achieved). Stop Category 1 may also be permitted when it is not possible to gain physical access to the machine before the safe stop is effected e.g. by:

- Covers and Gates which are locked until dangerous operations and functions have been stopped.
- Long distances between a safety device and dangerous machine functions.

Using this technique of stopping a machine provides many advantages i.e.:

- Machines last longer as they are not subjected to excessive loading etc when requested to stop.
- Parts being processed are not damaged.
- Restarting machines from stopped position is simplified.

A safe "Soft" stop is achieved by means of a safety relay giving a programme stop to the machine control system. e.g. when a gate is opened or emergency stop is activated. The output of the Safety relay is used to provide both a stop signal to the machine control system i.e. via a PLC which

applies the necessary braking/stopping of the machine in a controlled way, and to switch a delayed expansion relay e.g. JSR3T. The delayed safety outputs of the JSR3T expansion relay are then used to control the safe disconnection of the power to the actuators/motors etc. of the machine.

Safety level

The JSR3T has twin stop functions, using two positively guided contact relays.

In order to achieve the level of monitoring required the JSR3T must be used with a suitable Safety Relay e.g. JSBR4, or RT6. The JSR3T test output (terminals X1 and X2) must be connected to the test input of the Safety relay being expanded (see connection examples).

The JSR3T provides delay times that even in the event of an internal fault condition complies with the requirement that the set delay cannot increase in time.

Regulations and standards

The JSR3T is designed and approved in accordance with appropriate directives and standards. Examples of such are 98/37/EC, EN ISO 12100-1/-2, EN 60204-1, EN 954-1/ EN ISO 13849-1.

Connection examples

For examples of how our safety relays can solve various safety problems, please see the section "Connection examples".

Technical data – JSR3T

Manufacturer	ABB AB/Jokab Safety, Sweden
Article number/Ordering data JSR3T 24 AC/DC	2TLJ010017R0100
Colour	Black and beige
Power supply	24 VAC/DC, 50 - 60 Hz
Power consumption	1,3 VA/W
Relay Outputs	2 x 1 NO (See Connection examples)
Max. switching capacity Resistive load AC Inductive load AC Resistive load DC Inductive load DC	4A/250VAC/1000 VA AC15 240VAC 3A 4A/24 VDC/100 W DC13 24VDC 2A
Max. res. load total switching capacity:	6A distributed on all contacts
Min. load	10mA/10V (if load on contact has not exceeded 100 mA)
Contact material	AgNi
Fuses Output (External)	3A gL/gG or 4A fast
Conditional short-circuit current (1 kA)	6A gG
Max Input Wire res. at nom. voltage	100 Ohm
Response time at activation	<20ms
Response time at deactivation	<0.5 - 10.0 sec. at nom. voltage. Selected delay can be lowered by up to approx. 30% by means of preset potentiometer on front panel.

Terminals (Max. screw torque 1 Nm)	Single strand: 2x1.5 mm ² Conductor with socket contact: 2x1mm ² .
Mounting	35 mm DIN-rail
Protection class enclosure/ terminals	IP 40/20 IEC 60529
Impulse Withstand Voltage	2.5kV
Pollution Degree	2
Operating temperature range	-10°C to +55°C (with no icing or condensation)
Operating humidity range	35% to 85%
LED indication	Outputs
Weight	158 g
Performance (max.) Functional test: The relays must be cycled at least once a year.	Category 4/PL e (EN ISO 13849-1:2008) SIL 3 (EN 62061:2005) PFH _d 3.67E-09
Conformity	2006/42/EC, 2006/95/EC, 2004/108/EC EN 954-1:1996, EN 62061:2005 EN ISO 13849-1:2008

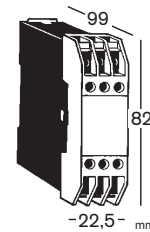

Technical description – JSR3T

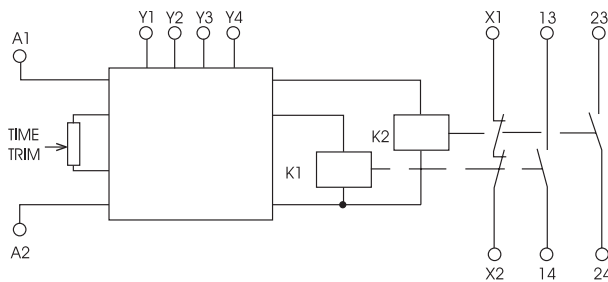

When supply voltage is connected to A1 and A2, relays K1 and K2 are activated. When the supply voltage is removed relays K1 and K2 remain energized for a time period de-

termined by the hardwire link configuration chosen (set by connecting links on the terminals Y1, Y2, Y3 and Y4.) and the setting of the Time Trim potentiometer.

NOTE 1

Max. time set by hardwire links can only be reduced (up to approx. 30% reduction) by Time Trim potentiometer.

NOTE 2

Both the output contacts of K1 and K2 (13 - 14 and 23 - 24) must be used. Output contacts must be either connected in series (forming one safety output) or used in parallel circuits in order to obtain necessary redundancy.

Electrical connection – JSR3T

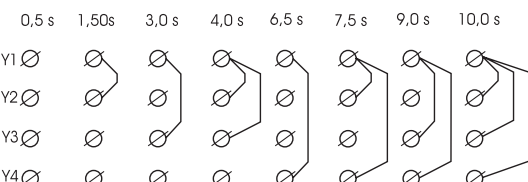
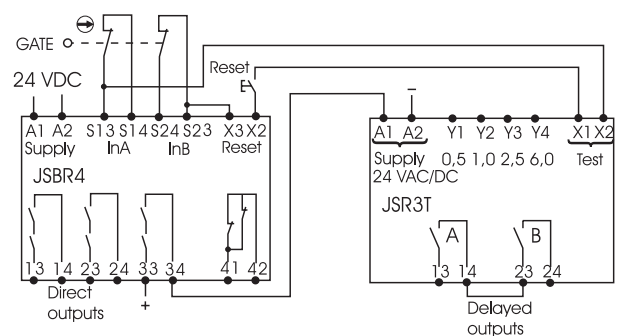
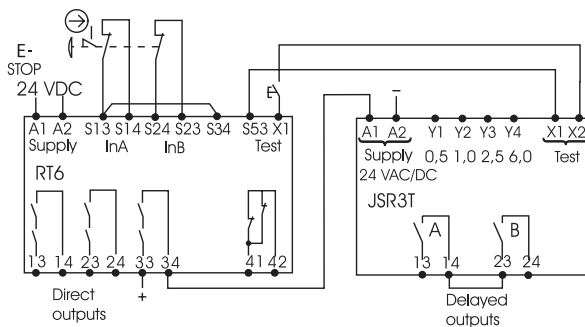

It is recommended that all switched loads are adequately suppressed and/or fused in order to provide additional protection for the safety contacts.

Selection of time delay by hardwire links (Y1, Y2, Y3, Y4).

Selected delay can be lowered by up to approx. 30% by means of preset potentiometer on front panel.

Contents - Connection examples

Page

HA5400A Connection examples JSBR4	6:43
HA6400A Connection examples JSBT4	6:43
HA6500A Connection examples JSBT5	6:44
HA6500B Connection examples BT50	6:44
HA6501B Connection examples BT50T	6:45
HA6500C Connection examples BT51	6:45
HA6501C Connection examples BT51T	6:46
HA7100A Connection examples JSBRT11	6:46
HA7600A Connection examples RT6	6:47
HA7600B Principle drawing RT6	6:47
HA7672A Enabling device JSHD4 - EX with RT6	6:48
HA7700A Connection examples RT7	6:48
HA7900A Connection examples RT9	6:49
HE3811B Safety Light Beam Spot with time-limited reset	6:49
HE3824C Lightbeam with time-limited bypass 0.2–40 s	6:50
HE3824E Lightbeams with time-limited bypass 0.2–40 s	6:50
HG7636B Focus light grid/curtain with three-position device	6:51
HG7611A Interlocked door with RT6 and pre-reset	6:51
HG7636A Interlocked door with three-position device	6:52
HG7646A Interlocked door with three-position device and time-limited entrance/exit	6:52
HG7654A Interlocked door with RT6 and output expansion JSR1T	6:53
HG7658A Interlocked door with RT6 and output expansion JSR2A	6:53
HG7673A Interlock switch JSNY8 with RT6	6:54
HG7674A Safety interlock switch JSNY9M/MLA with RT6	6:54
HG7674B Safety interlock switch JSNY9S/SLA with RT6	6:55
HH0000C Three-position device JSHD4 with various safety controllers	6:55
HI8552A Connection examples JSHT2 intermittent running	6:56
HK7600A Safety mat/Contact strip with RT6	6:56
HL7600B Several JSNY7 connected to one RT6 with unique indication	6:57
HM0000A Magnetic switch JSNY7 with various safety controllers	6:57
HN7660A Delayed outputs RT6 with output expansion JSR3T and RT7	6:58
HP7600A Machine control - Isolation of PLC inputs and outputs	6:58
HP7600B Machine control-Isolation of PLC outputs	6:59
HR7200B Focus light curtain/beam	6:59
HR7800B Focus lightbeam/curtain	6:60
HT5400A Two-hand device with safety relay JSBR4	6:60
HB0008A Focus light curtain/light beam connected to an RT9 with the aid of a M12-3D	6:61

HA5400A Connection examples JSBR4

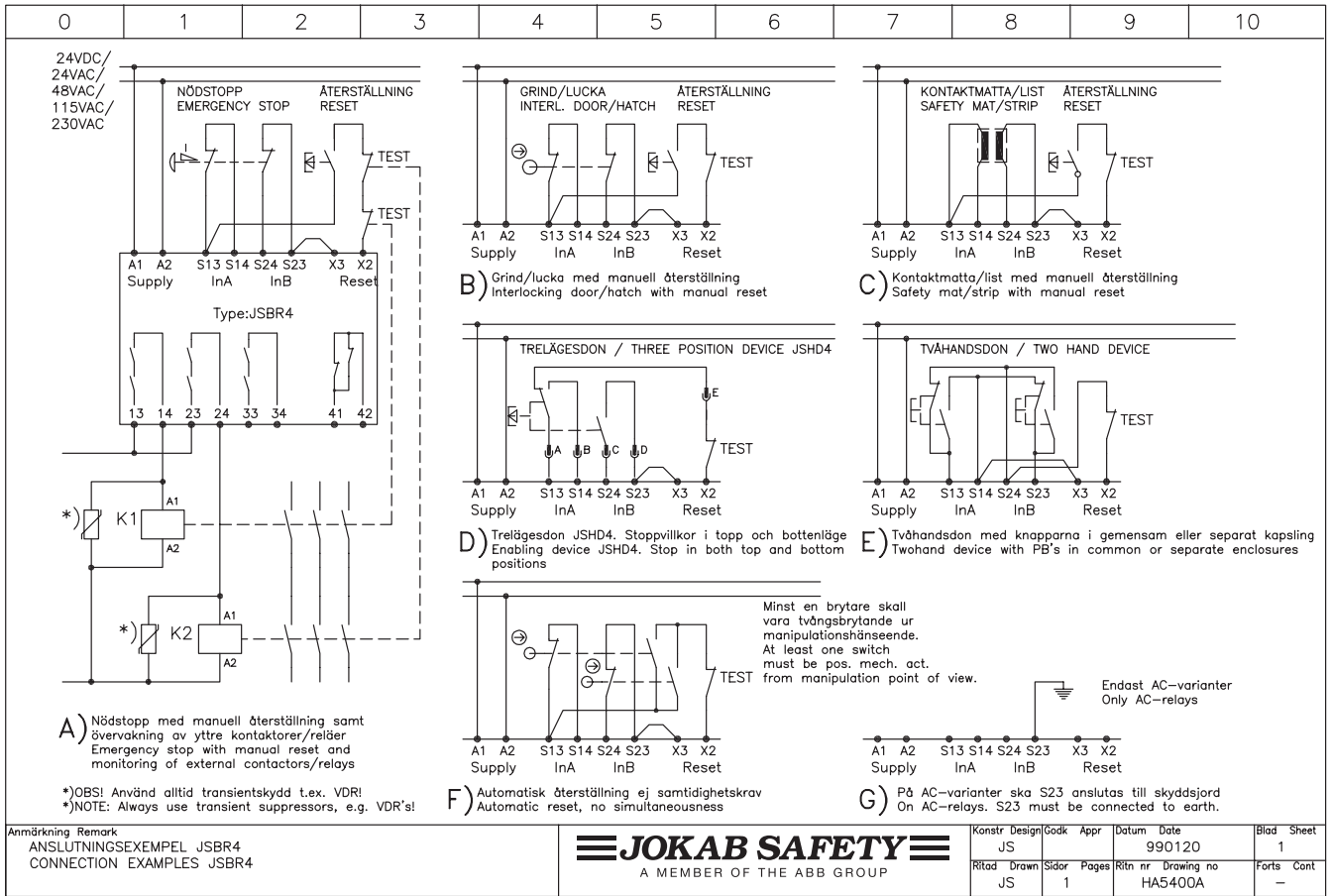

HA6400A Connection examples JSBT4

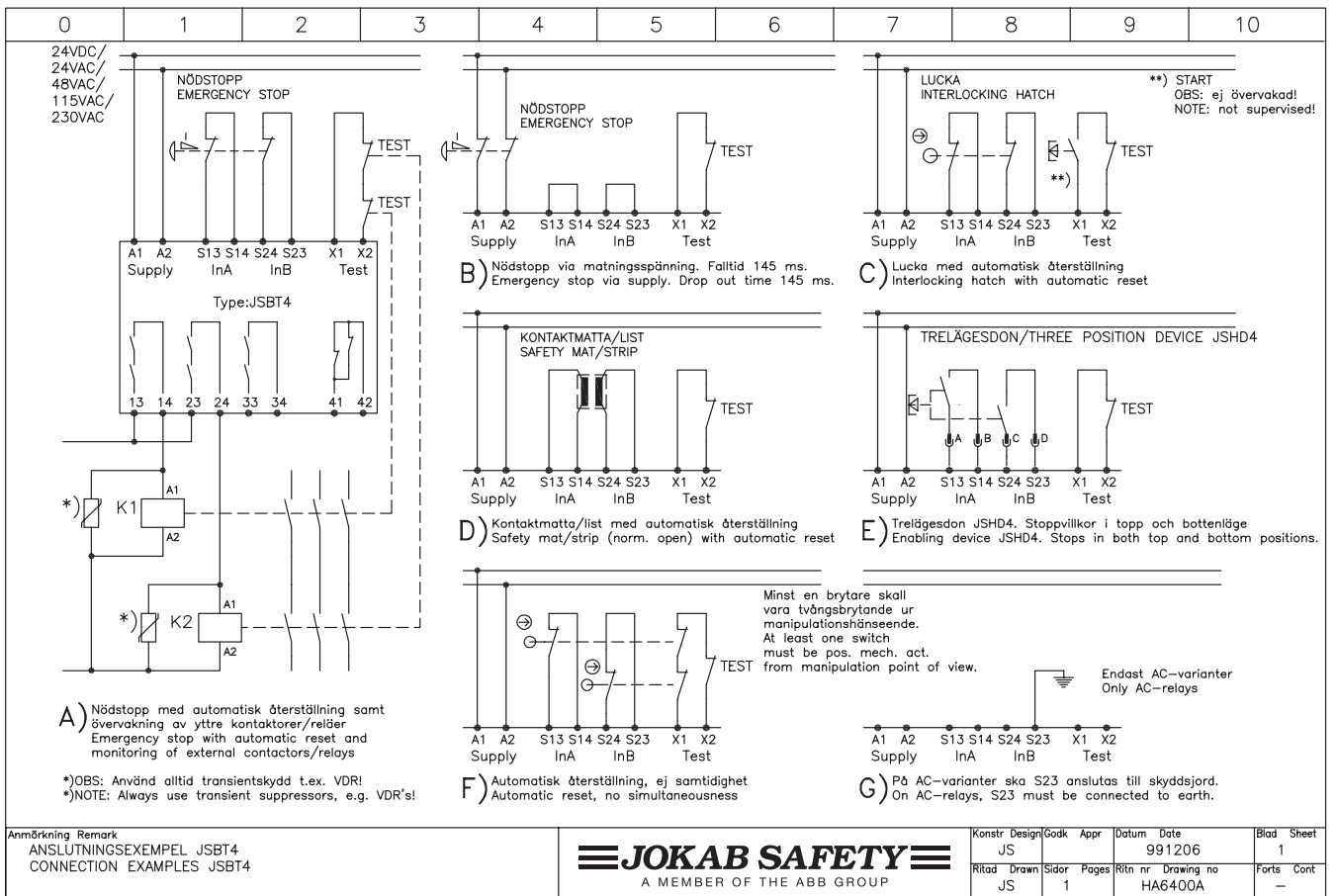

HA6500A Connection examples JSBT5

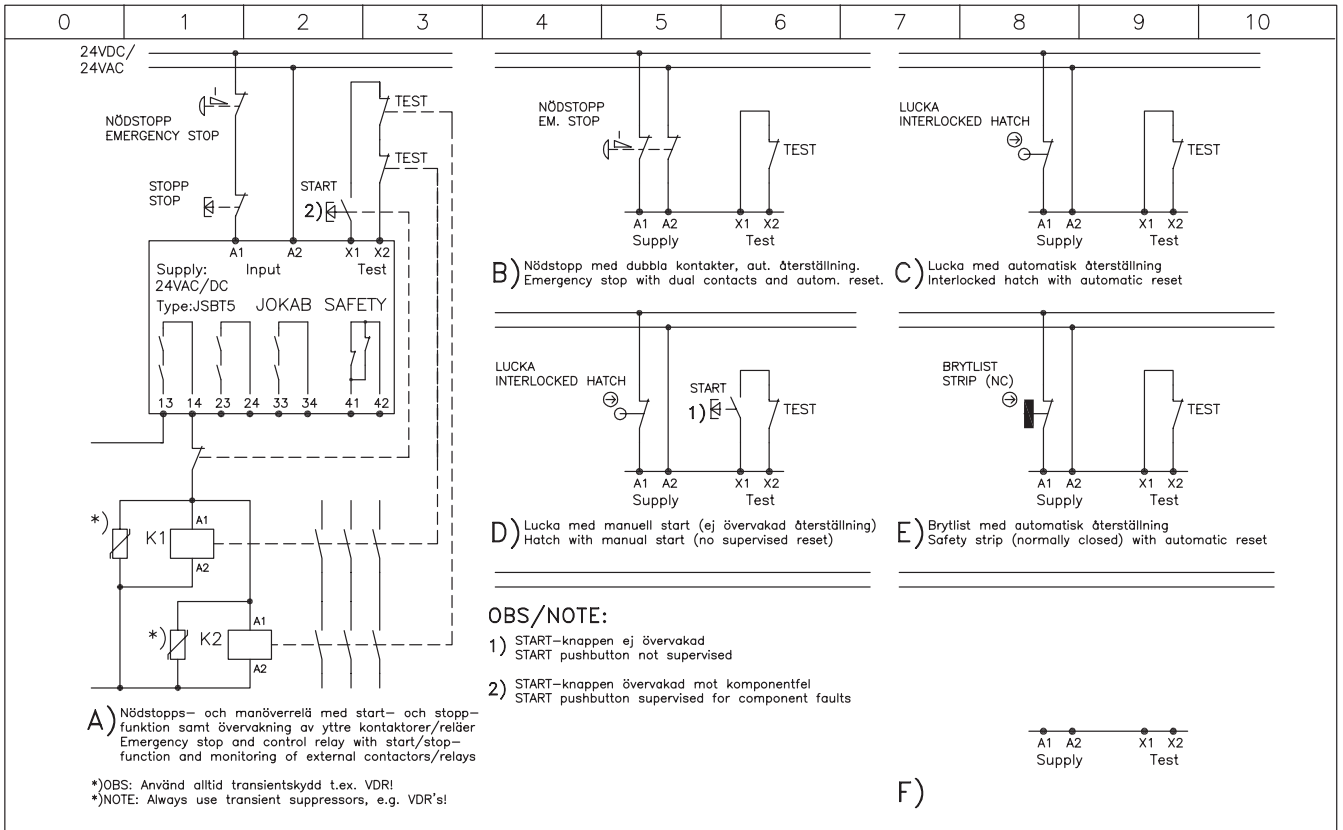

Anmärkning Remark ANSLUTNINGSEXEMPEL JSBT5 CONNECTION EXAMPLES JSBT5	≡ JOKAB SAFETY ≡ A MEMBER OF THE ABB GROUP				Konstr Design JS JS	Godk Appr JS JS	Datum Date 990120	Blad Sheet 1
	Ritad Drawn JS		Sidor Pages 1		Ritn nr Drawing no HA6500A		Forts Cont -	

It is the user's responsibility to ensure that all control devices are correctly installed, cared for and operated to meet all applicable European, national and local codes/regulations. Specifications subject to change without notice.

HA6500B Connection examples BT50

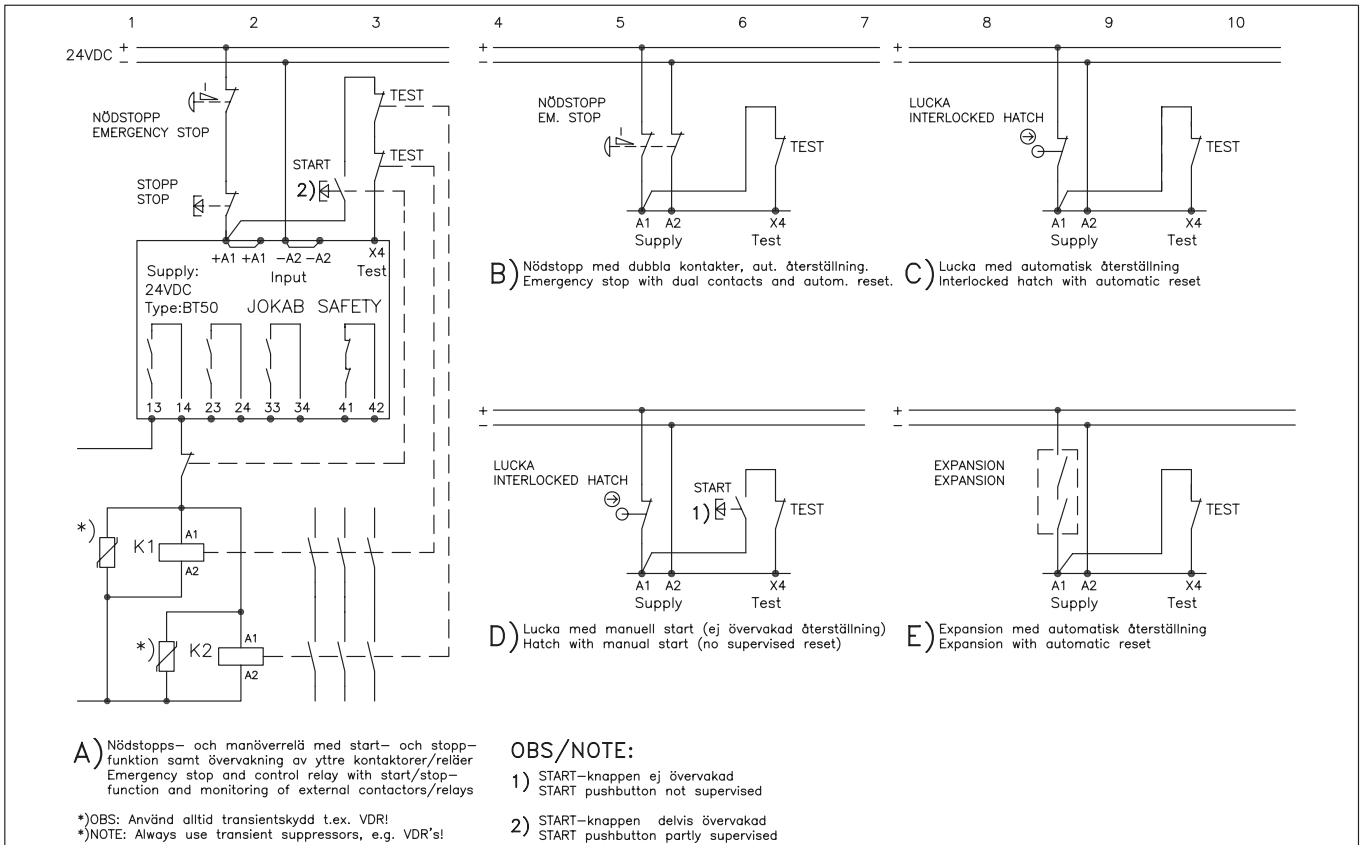

Anmärkning Remark ANSLUTNINGSEXEMPEL BT50 CONNECTION EXAMPLES BT50	≡ JOKAB SAFETY ≡ A MEMBER OF THE ABB GROUP				Konstr Design JS JS	Godk Appr JS JS	Datum Date 20070823	Blad Sheet 1
	Ritad Drawn JS		Sidor Pages 1		Ritn nr Drawing no HA6500B		Forts Cont -	

It is the user's responsibility to ensure that all control devices are correctly installed, cared for and operated to meet all applicable European, national and local codes/regulations. Specifications subject to change without notice.

HA6501B Connection examples BT50T

A) Nödstopps- och manöverrelä med start- och stopp-funktion samt övervakning av yttre kontaktorer/reläer
Emergency stop and control relay with start/stop-function and monitoring of external contactors/relays

B) Nödstopps med dubbla kontakter, aut. återställning.
Emergency stop with dual contacts and autom. reset.

C) Lucka med automatisk återställning
Interlocked hatch with automatic reset

D) Lucka med manuell start (ej övervakad återställning)
Hatch with manual start (no supervised reset)

E) Expansion med automatisk återställning
Expansion with automatic reset

F) BT50T Info utgång
BT50T Info. output

G) BT50T Fördröjningstider
BT50T Delay times

OBS/NOTE:
1) START-knappen ej övervakad
START pushbutton not supervised
2) START-knappen delvis övervakad
START pushbutton partly supervised

Anmärkning Remark
ANSLUTNINGSEXEMPEL BT50T
CONNECTION EXAMPLES BT50T

Konstr JS	Design JS	Godk JS	Appr JS	Datum 20070823	Date	Blad	Sheet
Ritad JS	Drawn JS	Sidor 1	Pages 1	Ritn nr HA6501B	Drawing no	Forts	Cont

It is the user's responsibility to ensure that all control devices are correctly installed, cared for and operated to meet all applicable European, national and local codes/regulations. Specifications subject to change without notice.

HA6500C Connection examples BT51

A) Nödstopps- och manöverrelä med start- och stopp-funktion samt övervakning av yttre kontaktorer/reläer
Emergency stop and control relay with start/stop-function and monitoring of external contactors/relays

B) Nödstopps med dubbla kontakter, aut. återställning.
Emergency stop with dual contacts and autom. reset.

C) Lucka med automatisk återställning
Interlocked hatch with automatic reset

D) Lucka med manuell start (ej övervakad återställning)
Hatch with manual start (no supervised reset)

E) Expansion med automatisk återställning
Expansion with automatic reset

OBS/NOTE:
1) START-knappen ej övervakad
START pushbutton not supervised
2) START-knappen delvis övervakad
START pushbutton partly supervised

Anmärkning Remark
ANSLUTNINGSEXEMPEL BT51
CONNECTION EXAMPLES BT51

Konstr JS	Design JS	Godk JS	Appr JS	Datum 20070828	Date	Blad	Sheet
Ritad JS	Drawn JS	Sidor 1	Pages 1	Ritn nr HA6500C	Drawing no	Forts	Cont

It is the user's responsibility to ensure that all control devices are correctly installed, cared for and operated to meet all applicable European, national and local codes/regulations. Specifications subject to change without notice.

HA6501C Connection examples BT51T

A) Nödstopps- och manöverrelä med start- och stopp-funktion samt övervakning av yttre kontaktorer/reläer
Emergency stop and control relay with start/stop-function and monitoring of external contactors/relays

B) Nödstopp med dubbla kontakter, aut. återställning.
Emergency stop with dual contacts and automatic reset.

C) Lucka med automatisk återställning
Interlocked hatch with automatic reset

D) Lucka med manuell start (ej övervakad återställning)
Hatch with manual start (no supervised reset)

E) Expansion med automatisk återställning
Expansion with automatic reset

F) BT51T Info utgång
BT51T Info. output

G) BT51T Fördörningstider
BT51T Delay times

OBS/NOTE:
1) START-knappen ej övervakad
START pushbutton not supervised
2) START-knappen delvis övervakad
START pushbutton partly supervised

Anmärkning Remark
ANSLUTNINGSEXEMPEL BT51T
CONNECTION EXAMPLES BT51T

Konstr JS	Design JS	Godk JS	Appr JS	Datum 20070910	Blad 1
Ritad JS	Drawn JS	Sidor 1	Pages 1	Ritn nr HA6501C	Forts Cont

It is the user's responsibility to ensure that all control devices are correctly installed, cared for and operated to meet all applicable European, national and local codes/regulations. Specifications subject to change without notice.

HA7100A Connection examples JSBRT11

A) Nödstopp med manuell återställning samt övervakning av yttre kontaktorer/reläer
Emergency stop with manual reset and monitoring of external contactors/relays

B) Grind/lucka med manuell återställning.
Interl. door/hatch with manual reset.

C) Lucka med automatisk återställning.
Interl. hatch with automatic reset.

D) Nödstopp med automatisk återställning.
Emergency stop with automatic reset.

Anmärkning Remark
ANSLUTNINGSEXEMPEL JSBRT11
CONNECTION EXAMPLES JSBRT11

Konstr JS	Design JS	Godk JS	Appr JS	Datum 990120	Blad 1
Ritad JS	Drawn JS	Sidor 1	Pages 1	Ritn nr HA7100A	Forts Cont

It is the user's responsibility to ensure that all control devices are correctly installed, cared for and operated to meet all applicable European, national and local codes/regulations. Specifications subject to change without notice.

HA7600A Connection examples RT6

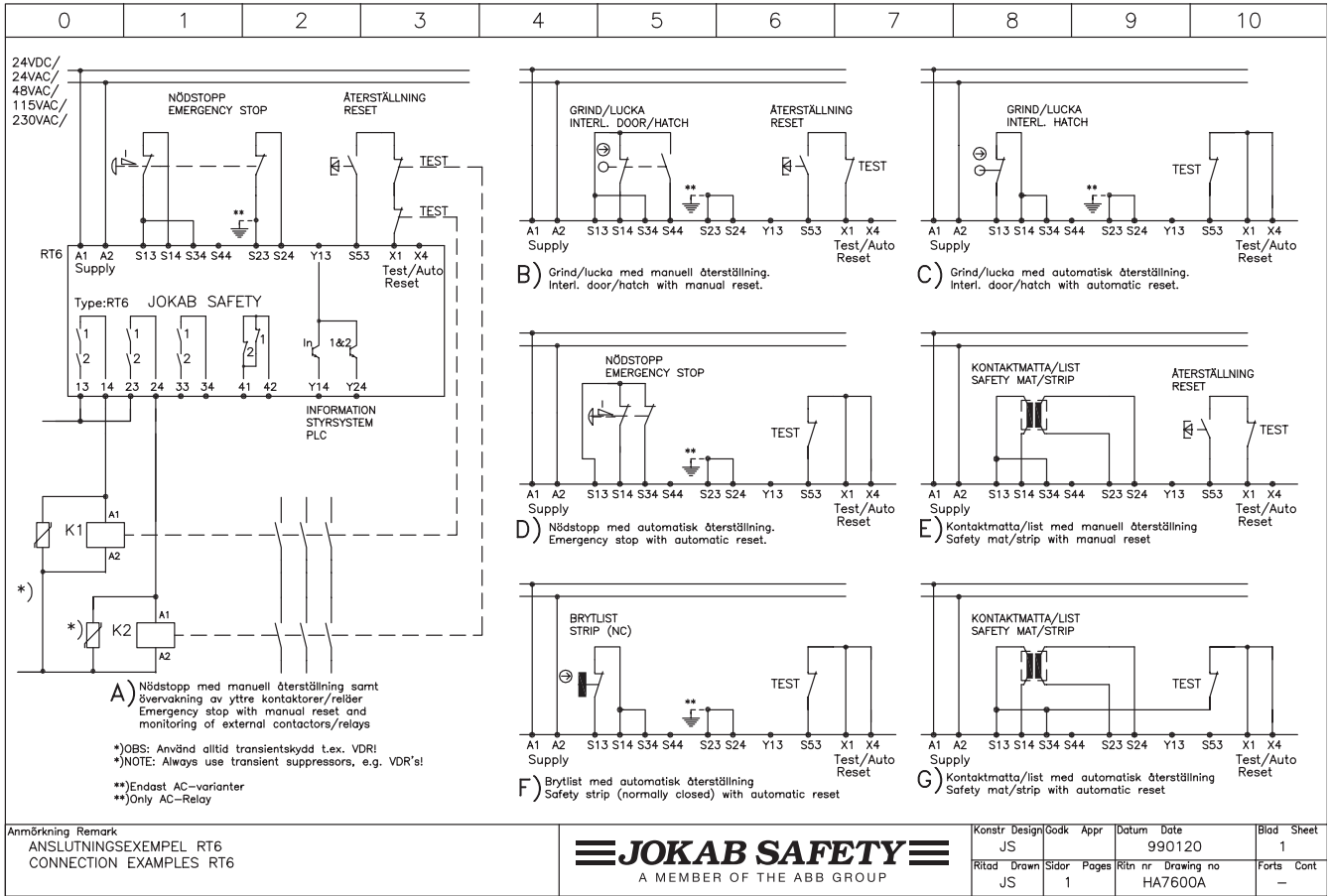

It is the user's responsibility to ensure that all control devices are correctly installed, cared for and operated to meet all applicable European, national and local codes/regulations. Specifications subject to change without notice.

HA7600B Principle drawing RT6

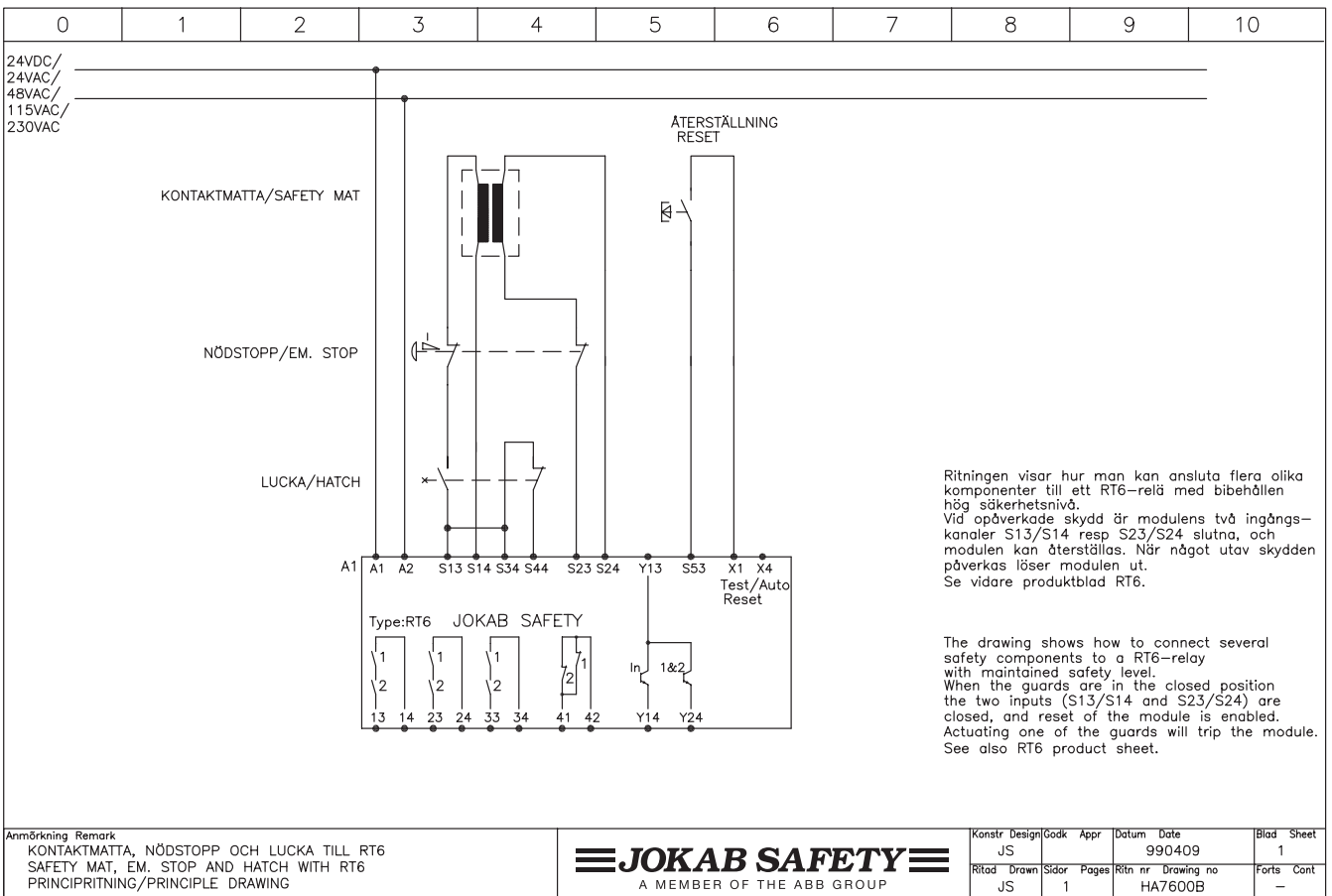

It is the user's responsibility to ensure that all control devices are correctly installed, cared for and operated to meet all applicable European, national and local codes/regulations. Specifications subject to change without notice.

HA7672A Enabling device JSHD4 - EX with RT6

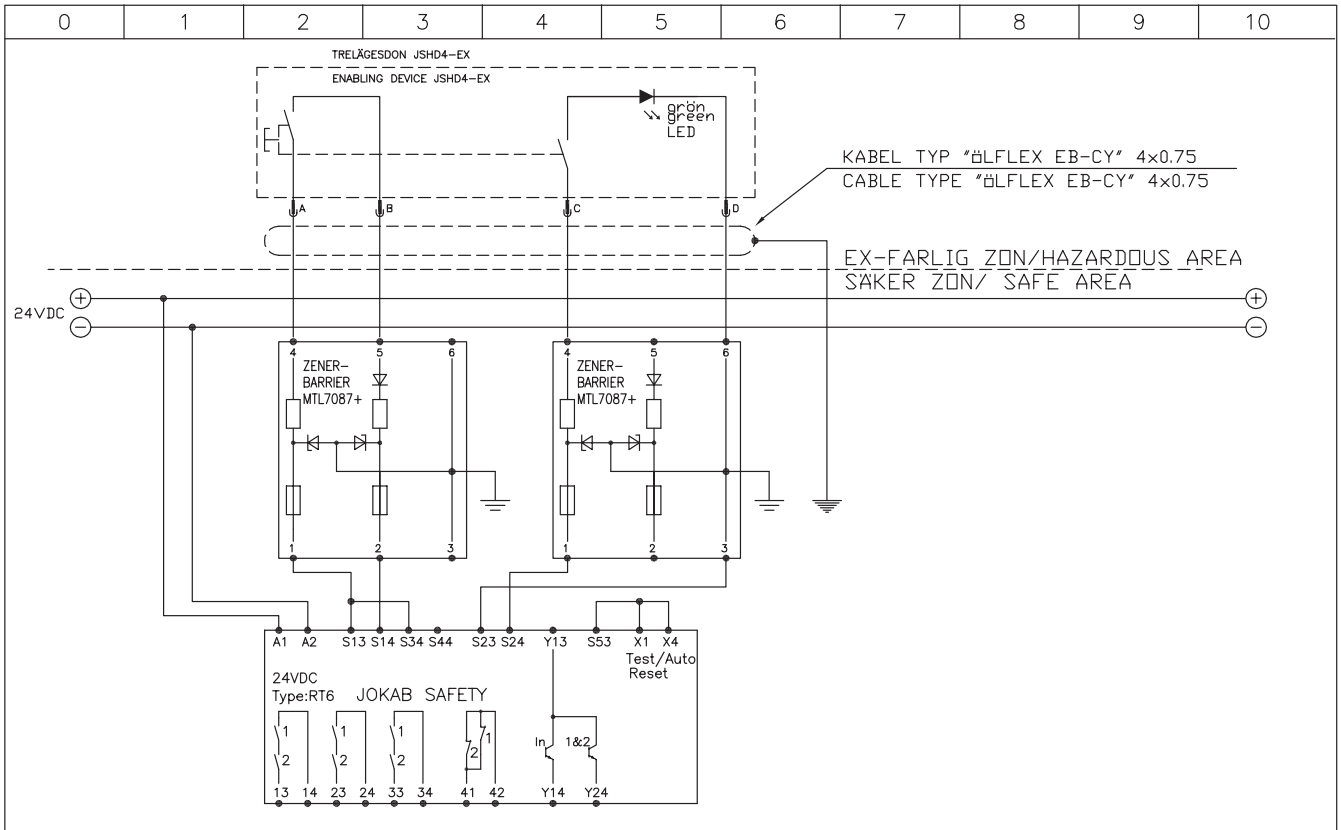

Anmärkning Remark TRELÄGESDON JSD4-EX MED RT6 ENABLING DEVICE JSHD4-EX WITH RT6	JOKAB SAFETY A MEMBER OF THE ABB GROUP				Konstr Design	Godk Appr	Datum Date	Blad Sheet
					JS	JS	990120	1
		Ritad Drawn	Sidor Pages	Ritn nr Drawing no	Forts Cont			
		JS	1	HA7672A	-			

It is the user's responsibility to ensure that all control devices are correctly installed, cared for and operated to meet all applicable European, national and local codes/regulations. Specifications subject to change without notice.

HA7700A Connection examples RT7

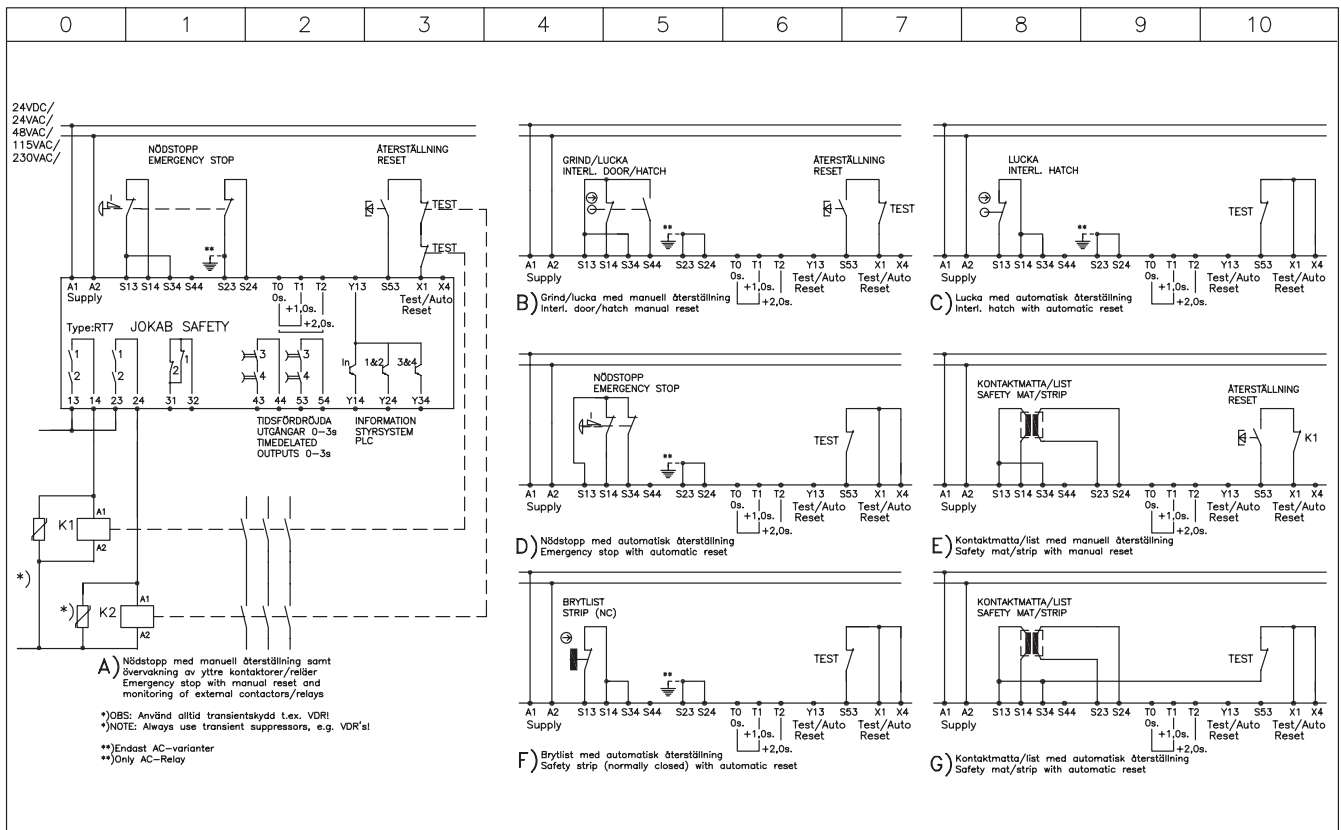

Anmärkning Remark ANSLUTNINGSEXEMPEL RT7 CONNECTION EXAMPLES RT7	JOKAB SAFETY A MEMBER OF THE ABB GROUP				Konstr Design	Godk Appr	Datum Date	Blad Sheet
					JS	JS	990120	1
		Ritad Drawn	Sidor Pages	Ritn nr Drawing no	Forts Cont			
		JS	1	HA7700A	-			

It is the user's responsibility to ensure that all control devices are correctly installed, cared for and operated to meet all applicable European, national and local codes/regulations. Specifications subject to change without notice.

HA7900A Connection examples RT9

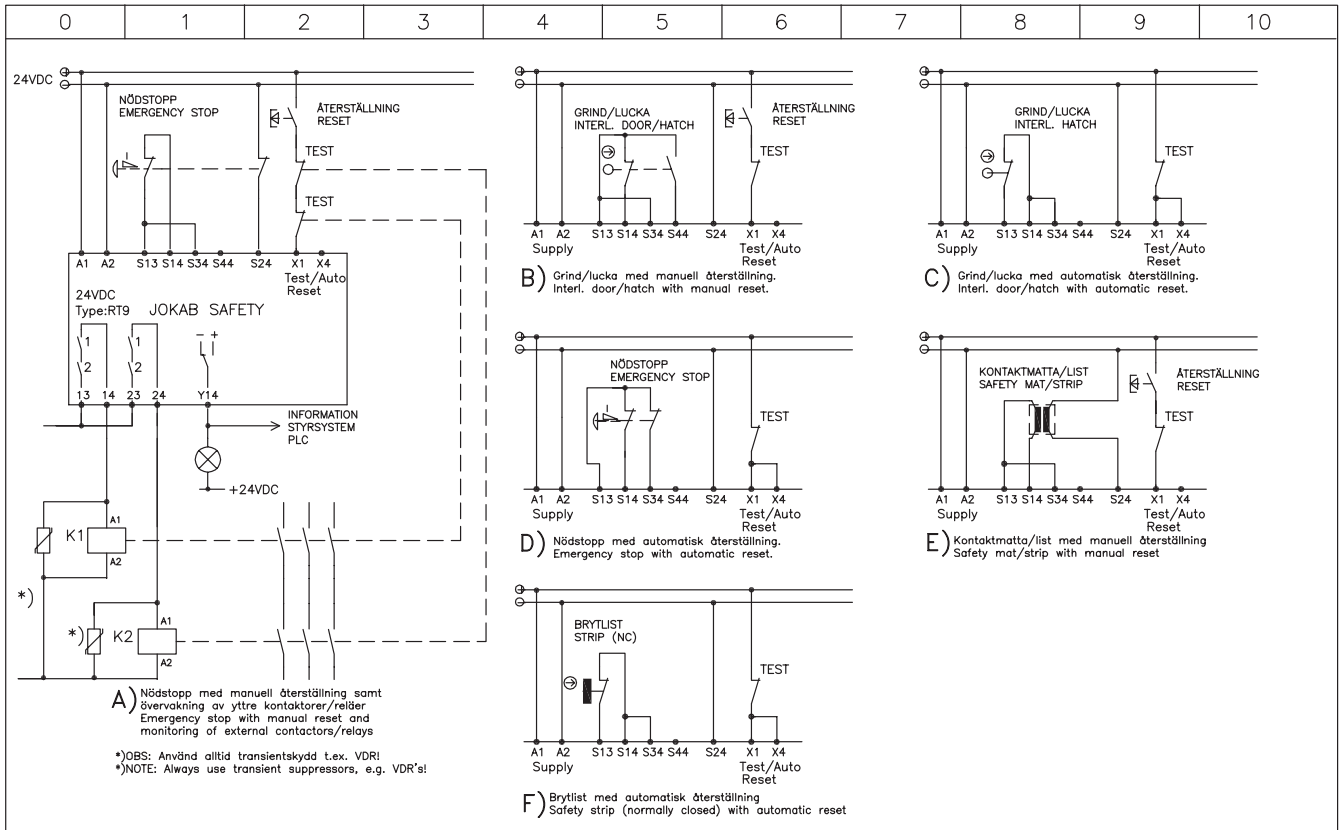

Anmärkning Remark ANSLUTNINGSEXEMPEL RT9 CONNECTION EXAMPLES RT9	JOKAB SAFETY A MEMBER OF THE ABB GROUP			Konstr Design JS	Godk Appr JS	Datum Date 990120	Blad Sheet 1
				Ritad Drawn JS	Sidor Pages 1	Ritn nr Drawing no HA7900A	Forts Cont -

It is the user's responsibility to ensure that all control devices are correctly installed, cared for and operated to meet all applicable European, national and local codes/regulations. Specifications subject to change without notice.

HE3811B Safety Light Beam Spot with time-limited reset

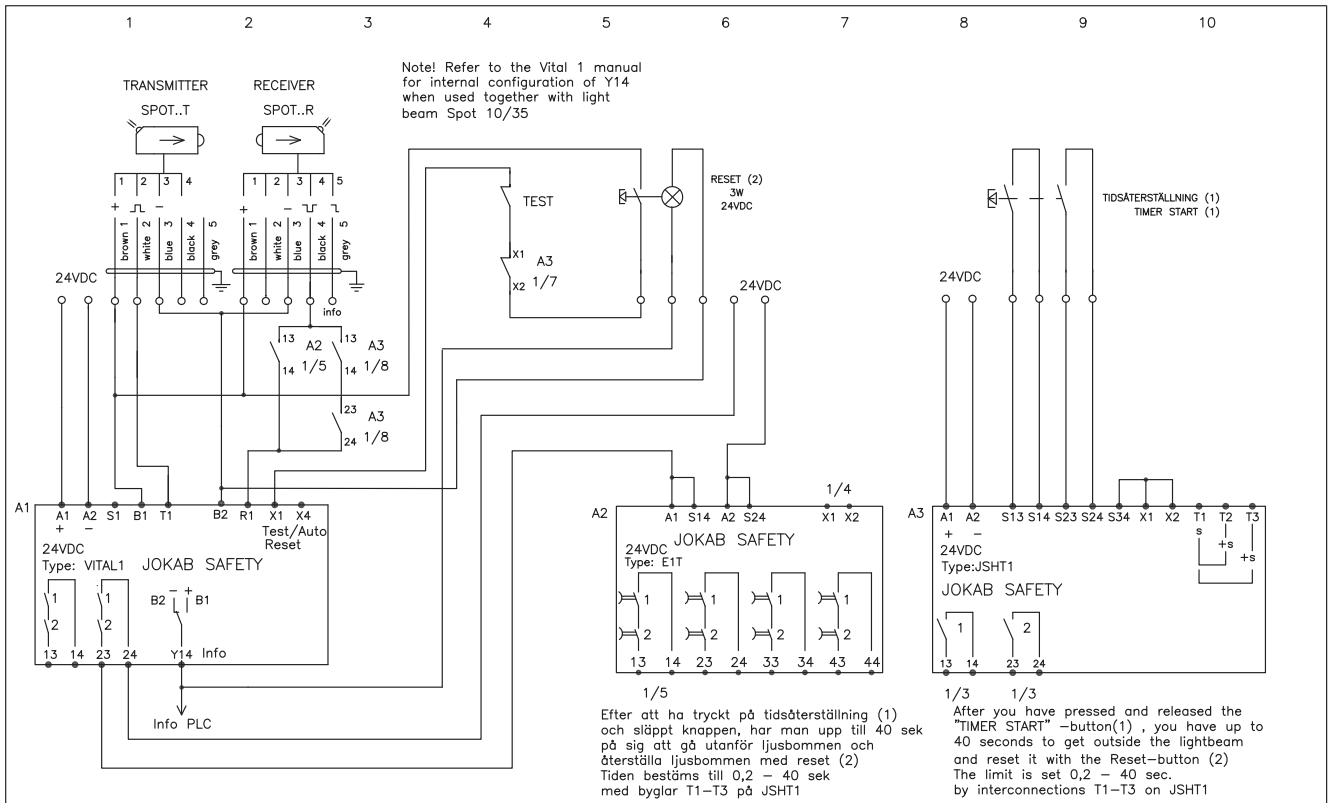

Anmärkning Remark LJUSBOM SPOT MED TIDSÅTERSTÄLLNING SAFETY LIGHT BEAM SPOT WITH TIME-LIMITED RESET	JOKAB SAFETY A MEMBER OF THE ABB GROUP			Konstr Design JS	Godk Appr JS	Datum Date 20110318	Blad Sheet 1
				Ritad Drawn JS	Sidor Pages 1	Ritn nr Drawing no HE3811B-01	Forts Cont -

HE3824C Lightbeam with time-limited bypass 0.2-40 s

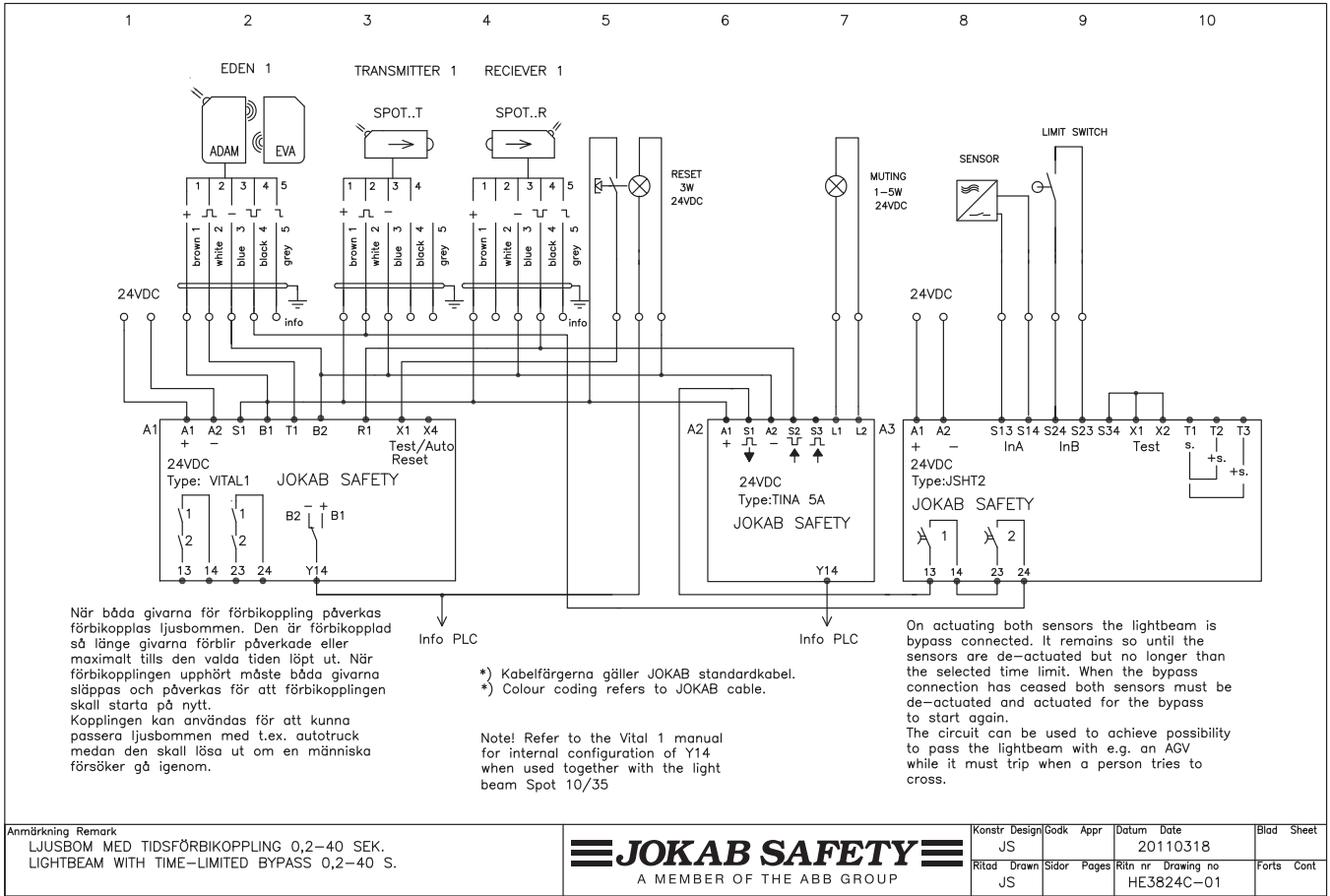

HE3824E Lightbeams with time-limited bypass 0.2-40 s

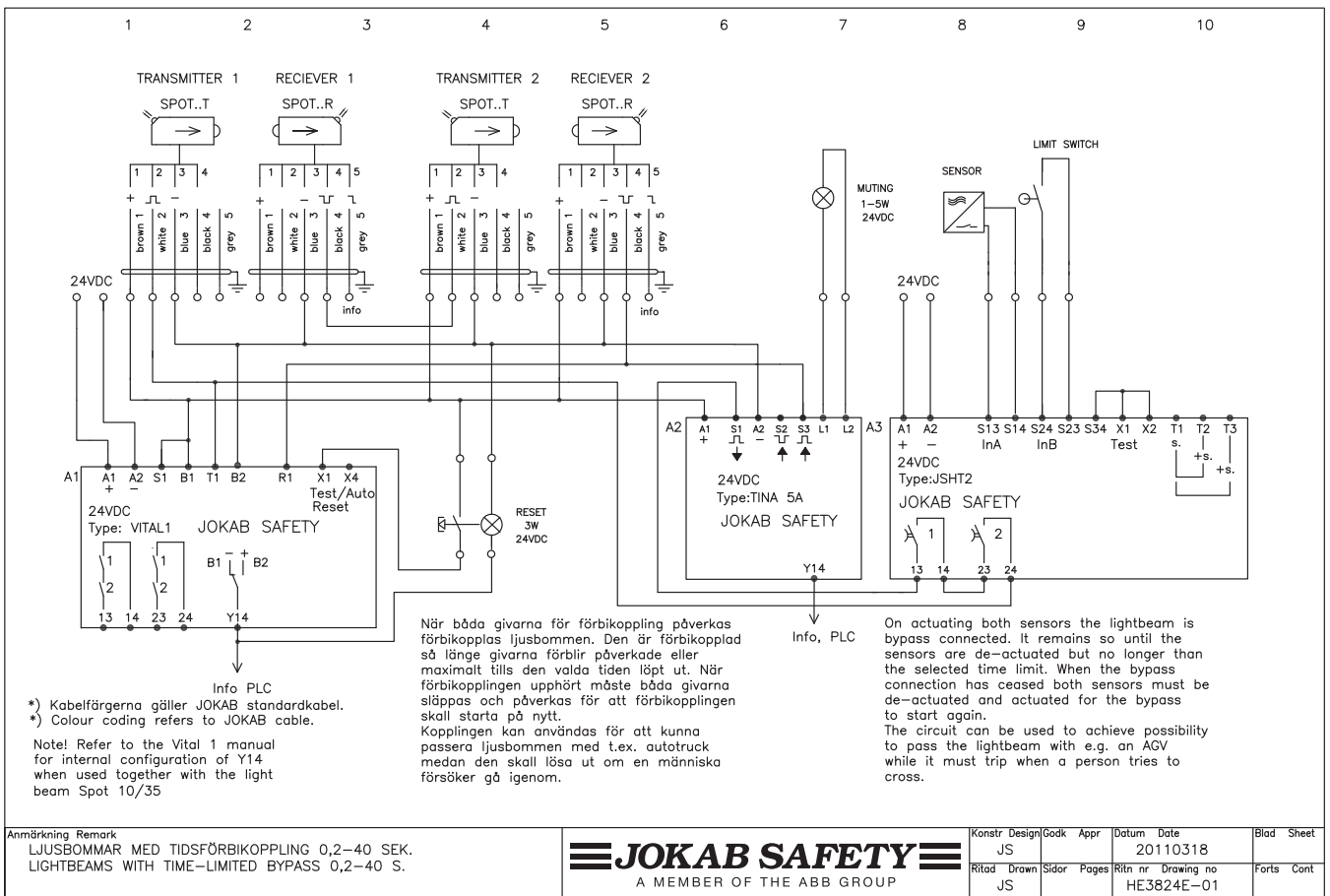

HG7636B Focus light grid/curtain with three-position device

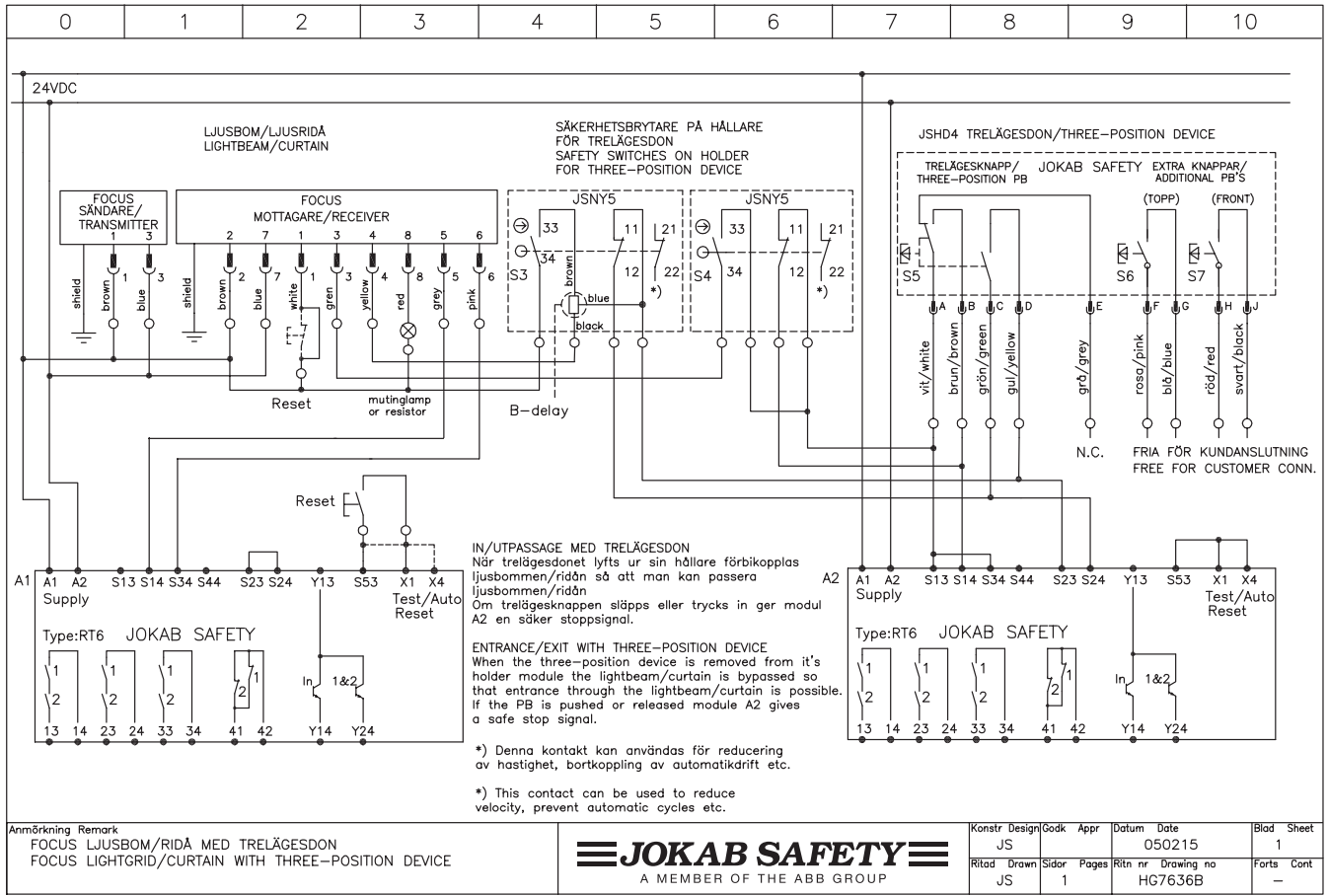

It is the user's responsibility to ensure that all control devices are correctly installed, cared for and operated to meet all applicable European, national and local codes/regulations. Specifications subject to change without notice.

HG7611A Interlocked door with RT6 and pre-reset

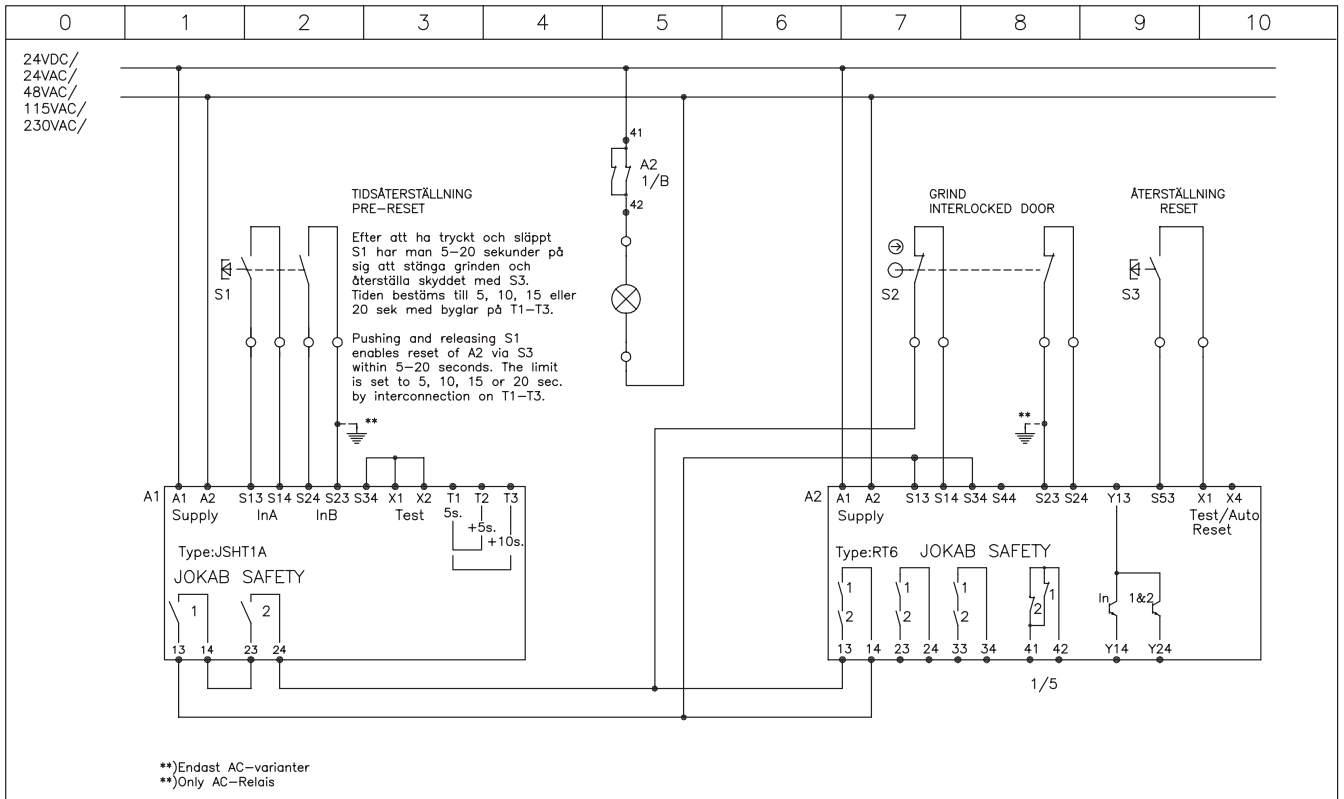

Anmärkning Remark GRIND MED RT6 OCH TIDSÅTERSTÄLLNING INTERLOCKED DOOR WITH RT6 AND PRE-RESET	JOKAB SAFETY A MEMBER OF THE ABB GROUP	Konstr Design JS	Godk Appr JS	Datum Date 990120	Blad Sheet 1
		Ritad Drawn JS	Sidor Pages 1	Ritn nr Drawing no HG7611A	Forts Cont -

It is the user's responsibility to ensure that all control devices are correctly installed, cared for and operated to meet all applicable European, national and local codes/regulations. Specifications subject to change without notice.

HG7636A Interlocked door with three-position device

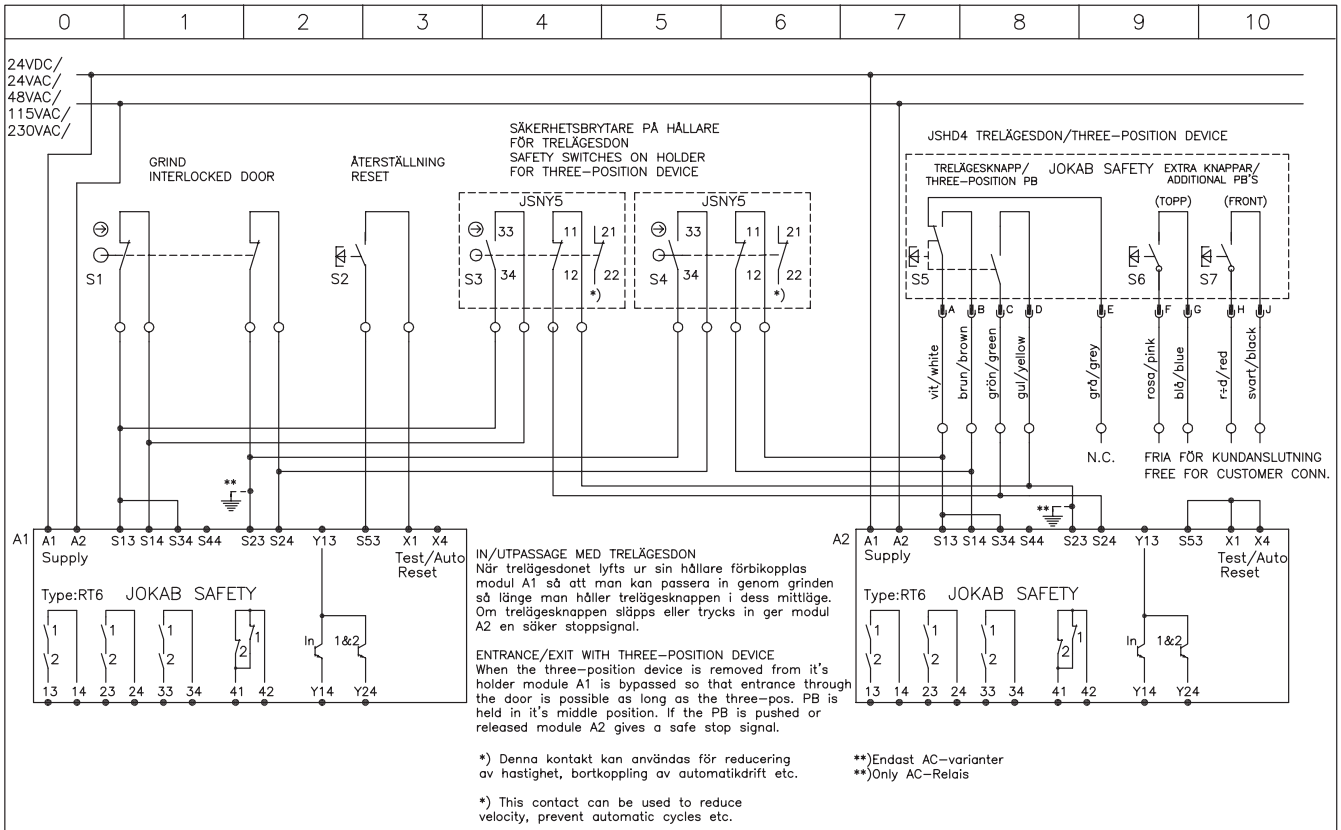

Anmärkning Remark	GRIND MED TRELÄGESDON INTERLOCKED DOOR WITH THREE-POSITION DEVICE	JOKAB SAFETY A MEMBER OF THE ABB GROUP	Konstr Design	Gödk Appr	Datum Date	Blad Sheet
			JS	JS	040311	1
			Ritad Drawn	Sidor Pages	Ritn nr Drawing no	Forts Cont
			JS	1	HG7636A	-

It is the user's responsibility to ensure that all control devices are correctly installed, cared for and operated to meet all applicable European, national and local codes/regulations. Specifications subject to change without notice.

HG7646A Interlocked door with three-position device and time-limited entrance/exit

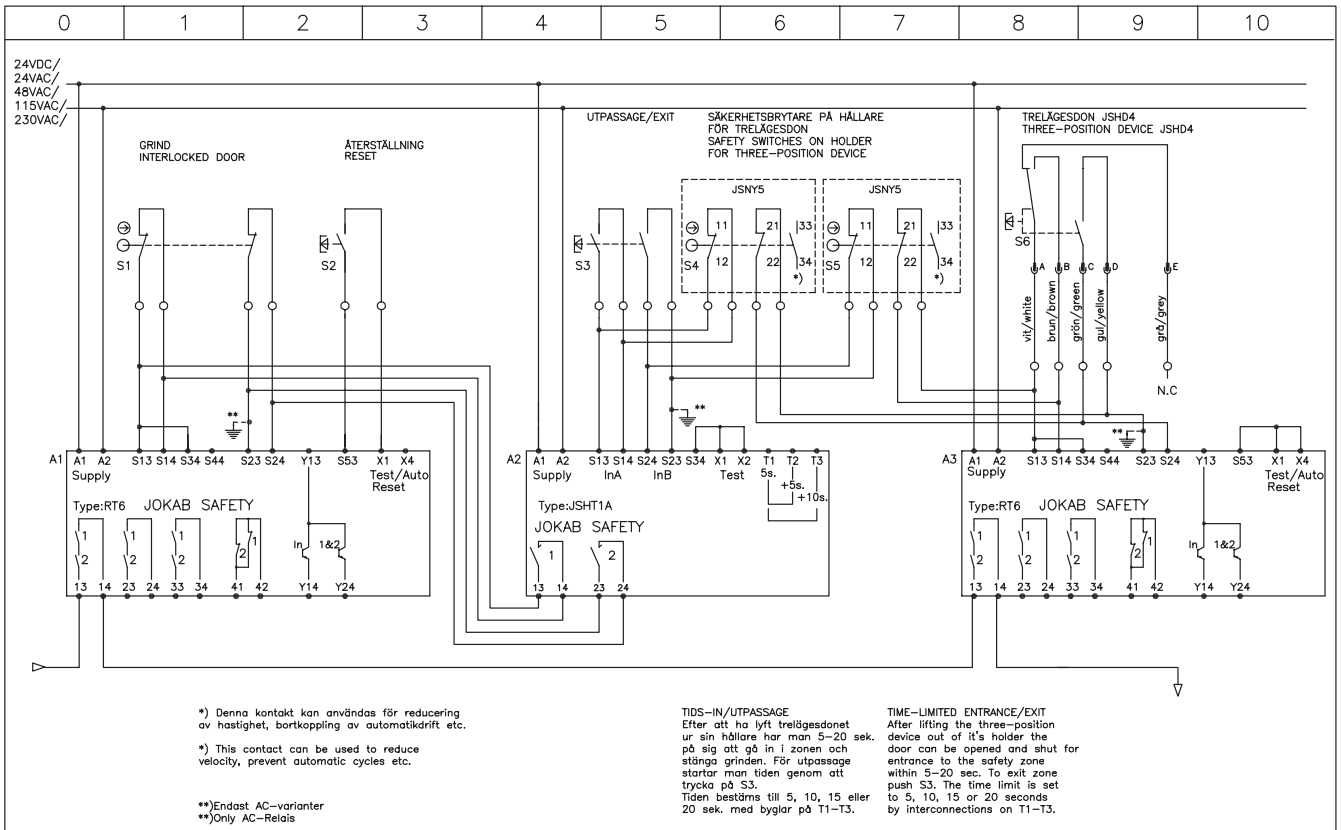

Anmärkning Remark	GRIND MED TRELÄGESDON OCH TIDS-IN/UTPASSAGE INTERLOCKED DOOR WITH THREE-POSITION DEVICE AND TIME-LIMITED ENTRANCE/EXIT	JOKAB SAFETY A MEMBER OF THE ABB GROUP	Konstr Design	Gödk Appr	Datum Date	Blad Sheet
			JS	JS	040311	1
			Ritad Drawn	Sidor Pages	Ritn nr Drawing no	Forts Cont
			JS	1	HG7646A	-

It is the user's responsibility to ensure that all control devices are correctly installed, cared for and operated to meet all applicable European, national and local codes/regulations. Specifications subject to change without notice.

HG7654A Interlocked door with RT6 and output expansion JSR1T

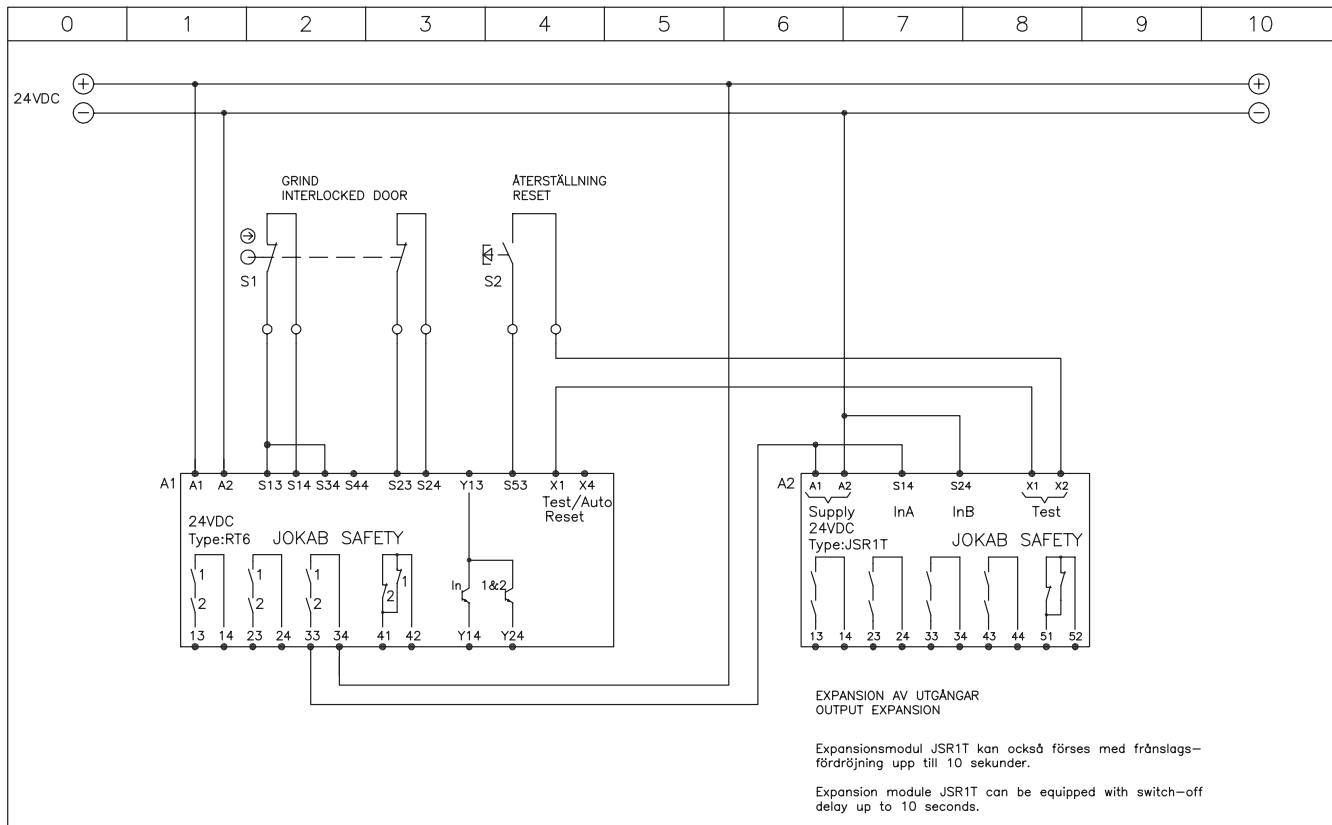

Anmärkning Remark GRIND MED RT6 OCH EXPANSION JSR1T INTERLOCKED DOOR WITH RT6 AND OUTPUT EXPANSION JSR1T	JOKAB SAFETY A MEMBER OF THE ABB GROUP	Konstr Design	JS	Datum Date	990120	Blad Sheet	1
		Ritad Drawn	JS	Sidor Pages	1	Ritn nr Drawing no	HG7654A

It is the user's responsibility to ensure that all control devices are correctly installed, cared for and operated to meet all applicable European, national and local codes/regulations. Specifications subject to change without notice.

HG7658A Interlocked door with RT6 and output expansion JSR2A

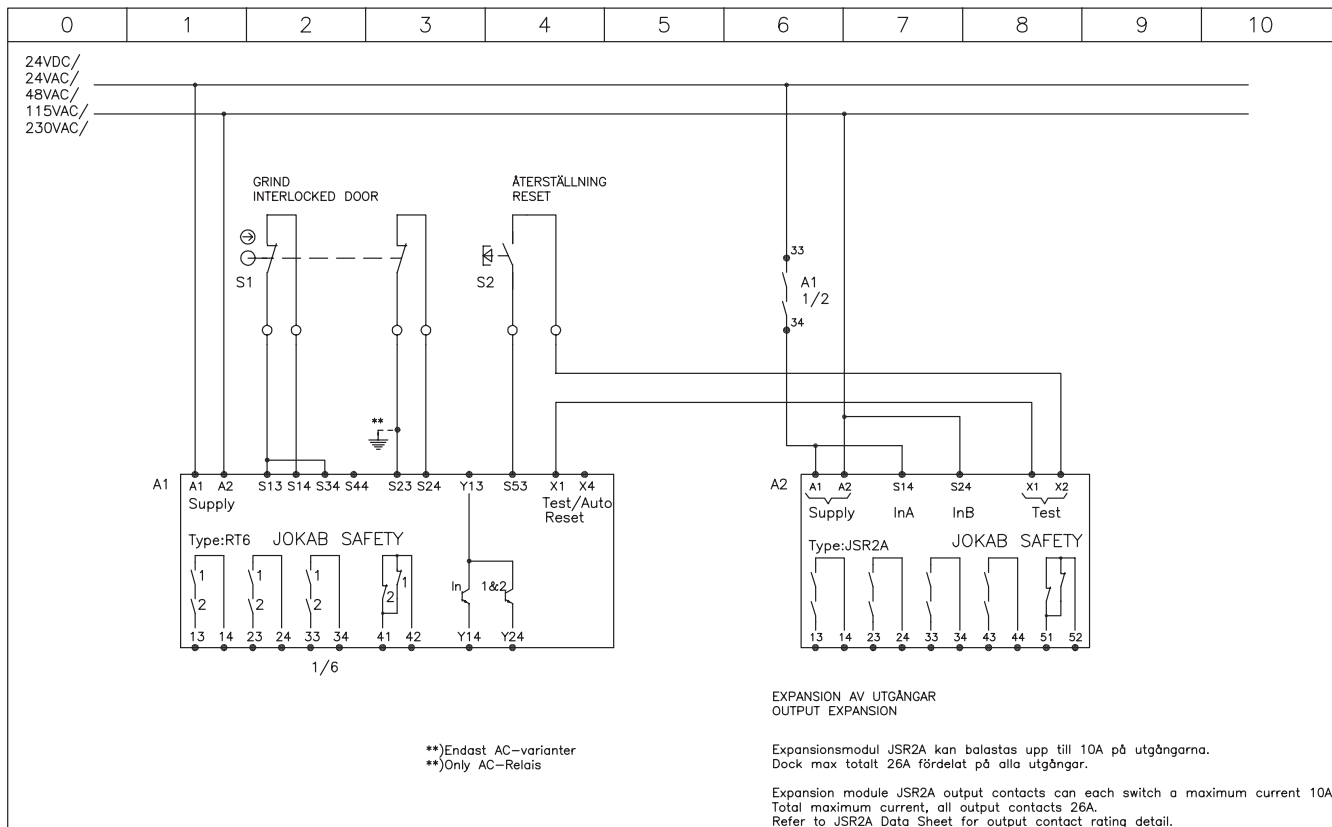

Anmärkning Remark GRIND MED RT6 OCH EXPANSION JSR2A INTERLOCKED DOOR WITH RT6 AND OUTPUT EXPANSION JSR2A	JOKAB SAFETY A MEMBER OF THE ABB GROUP	Konstr Design	JS	Datum Date	990120	Blad Sheet	1
		Ritad Drawn	JS	Sidor Pages	1	Ritn nr Drawing no	HG7658A

It is the user's responsibility to ensure that all control devices are correctly installed, cared for and operated to meet all applicable European, national and local codes/regulations. Specifications subject to change without notice.

HG7673A Interlock switch JSNY8 with RT6

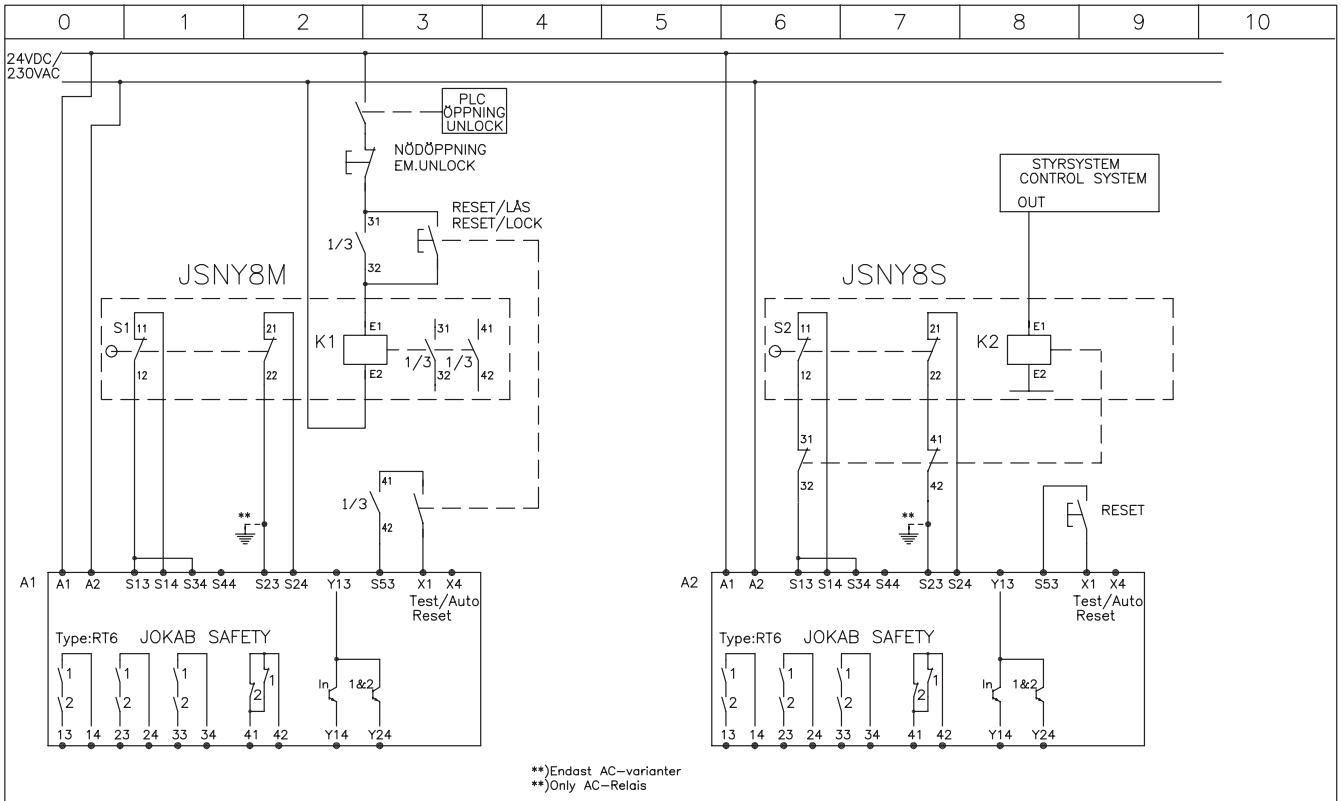

Anmärkning Remark NYCKELBRYTARE JSNY8 MED RT6 INTERLOCK SWITCH JSNY8 WITH RT6	JOKAB SAFETY A MEMBER OF THE ABB GROUP			Konstr JS	Design JS	Godk JS	Appr JS	Datum 990120	Blad 1	Sheet 1
	Ritad JS	Drawn JS	Sidor 1	Pages 1	Ritn nr HG7673A	Drawing no HG7673A	Forts -	Cont -		

It is the user's responsibility to ensure that all control devices are correctly installed, cared for and operated to meet all applicable European, national and local codes/regulations. Specifications subject to change without notice.

HG7674A Safety interlock switch JSNY9M/MLA with RT6

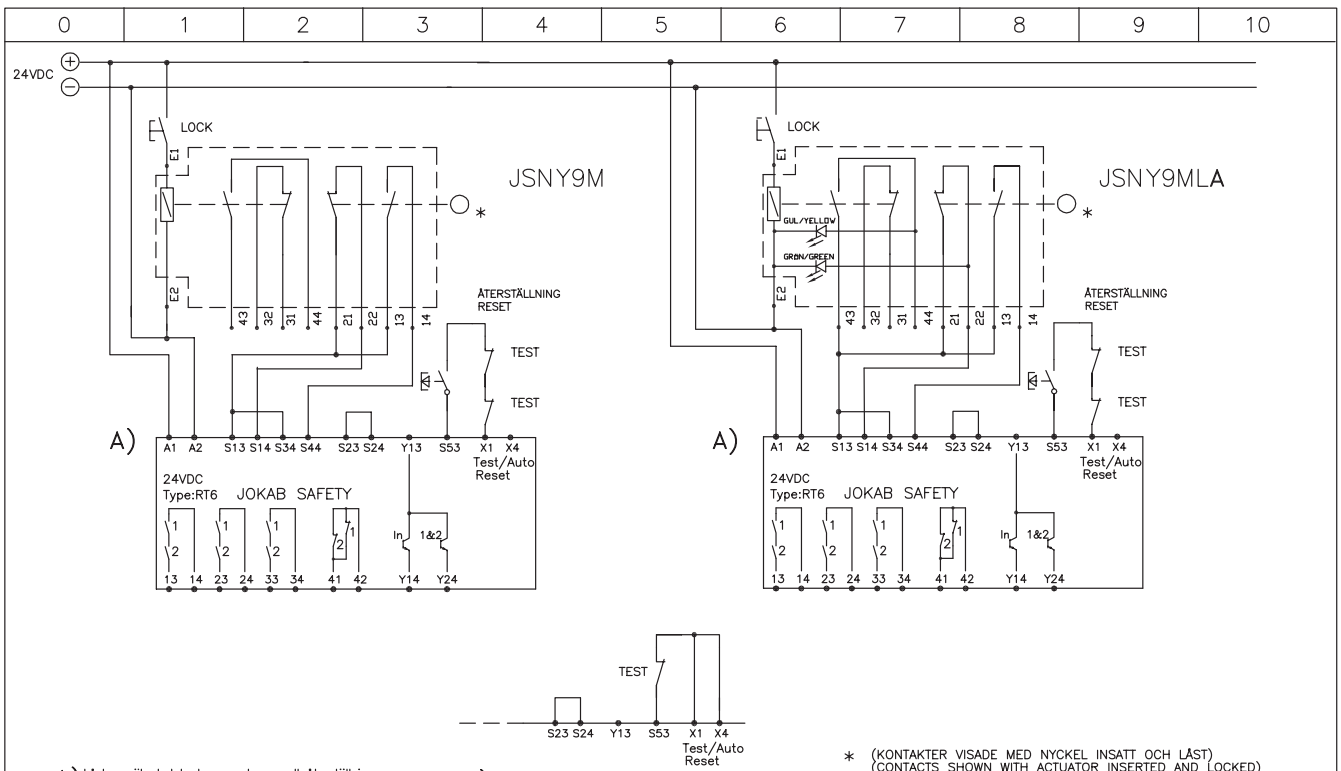

Anmärkning Remark LÅSBAR SÄKERHETSBRITARE JSNY9M/MLA MED RT6 SAFETY INTERLOCK SWITCH JSNY9M/MLA WITH RT6	JOKAB SAFETY A MEMBER OF THE ABB GROUP			Konstr JS	Design JS	Godk JS	Appr JS	Datum 040311	Blad 1	Sheet 1
	Ritad JS	Drawn JS	Sidor 1	Pages 1	Ritn nr HG7674A	Drawing no HG7674A	Forts -	Cont -		

It is the user's responsibility to ensure that all control devices are correctly installed, cared for and operated to meet all applicable European, national and local codes/regulations. Specifications subject to change without notice.

HG7674B Safety interlock switch JSNY9S/SLA with RT6

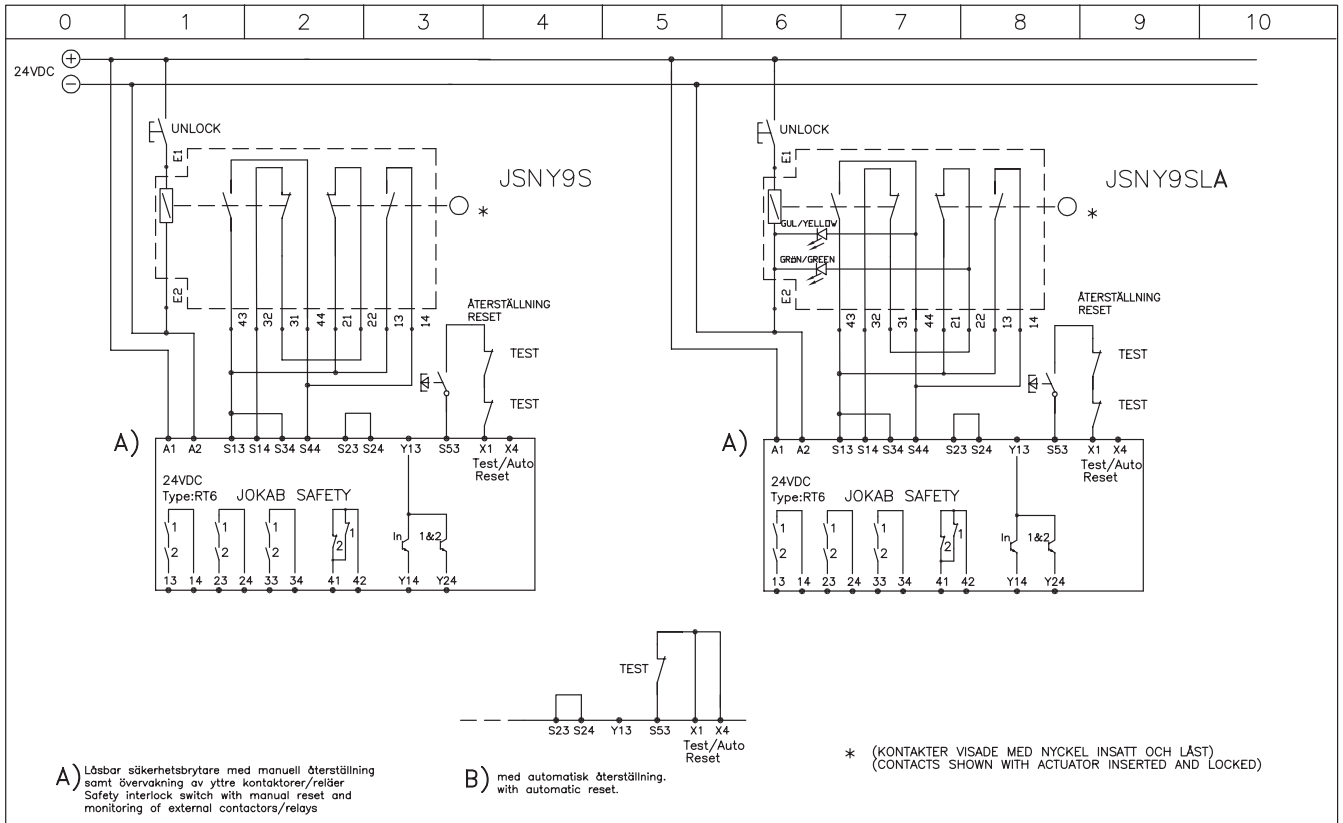

Anmärkning Remark LÄSBAR SÄKERHETSBRYTARE JSNY9S/SLA MED RT6 SAFETY INTERLOCK SWITCH JSNY9S/SLA WITH RT6	JOKAB SAFETY A MEMBER OF THE ABB GROUP				Konstr DesignCodk Appr Datum Date JS JS 991209	Blad Sheet 1
					Ritad Drawn Sidor Pages Ritn nr Drawing no JS JS 1 HG7674B	Forts Cont -

It is the user's responsibility to ensure that all control devices are correctly installed, cared for and operated to meet all applicable European, national and local codes/regulations. Specifications subject to change without notice.

HH000C Three-position device JSHD4 with various safety controllers

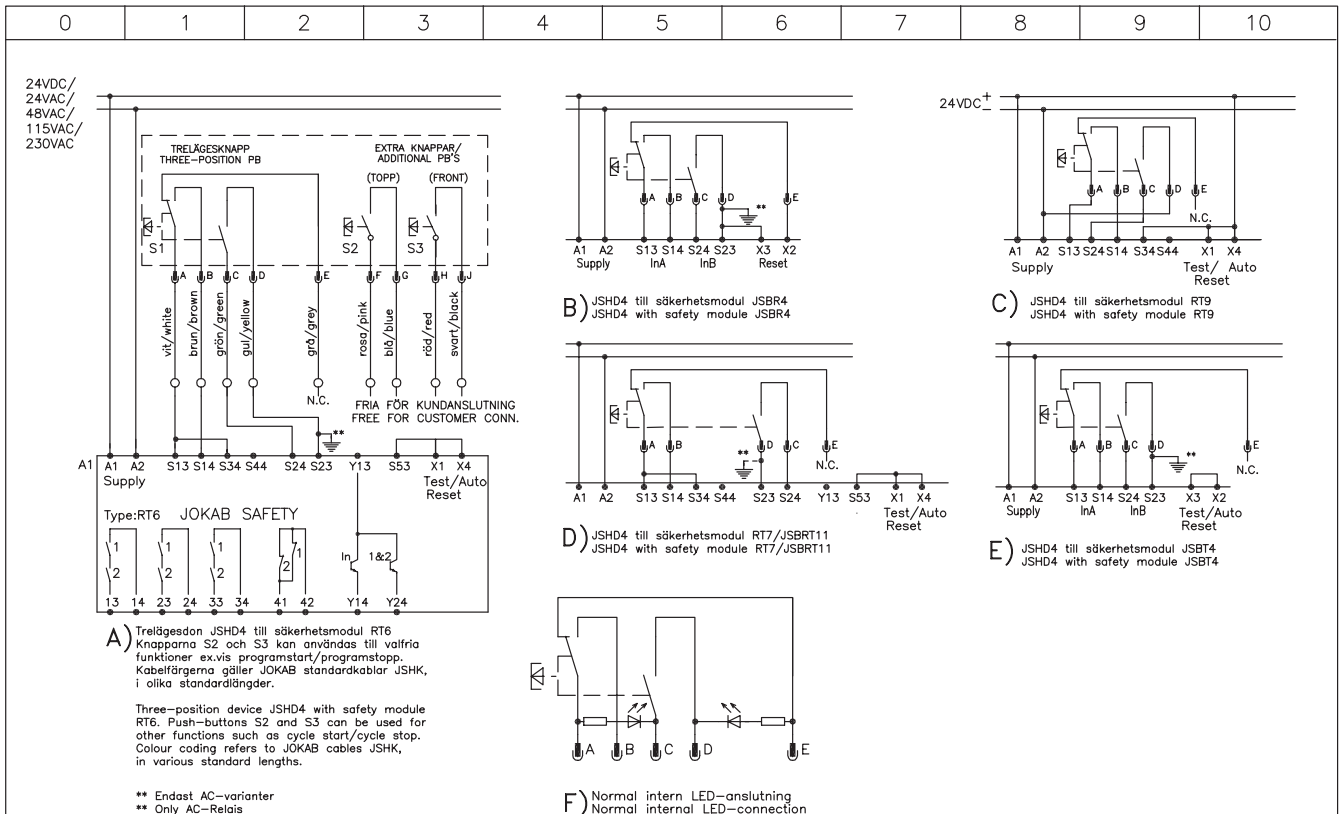

Anmärkning Remark TRELÄGESDON JSHD4 TILL OLIKA SÄKERHETSMODULER THREE-POSITION DEVICE JSHD4 WITH VARIOUS SAFETY MODULES	JOKAB SAFETY A MEMBER OF THE ABB GROUP				Konstr DesignCodk Appr Datum Date JS JS 050112	Blad Sheet 1
					Ritad Drawn Sidor Pages Ritn nr Drawing no JS JS 1 HH0000C	Forts Cont -

It is the user's responsibility to ensure that all control devices are correctly installed, cared for and operated to meet all applicable European, national and local codes/regulations. Specifications subject to change without notice.

HI8552A Connection examples JSHT2 intermittent running

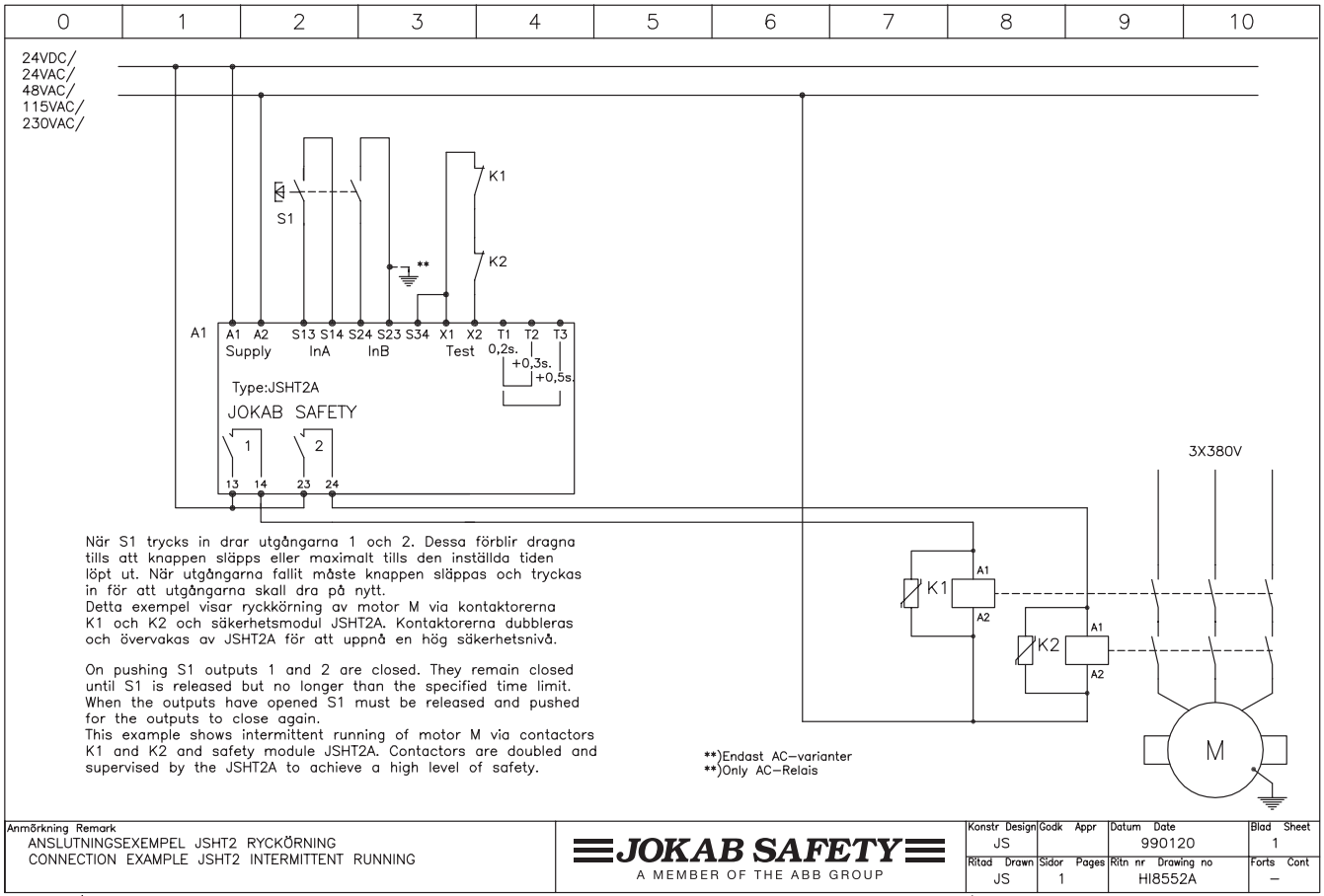

HK7600A Safety mat/Contact strip with RT6

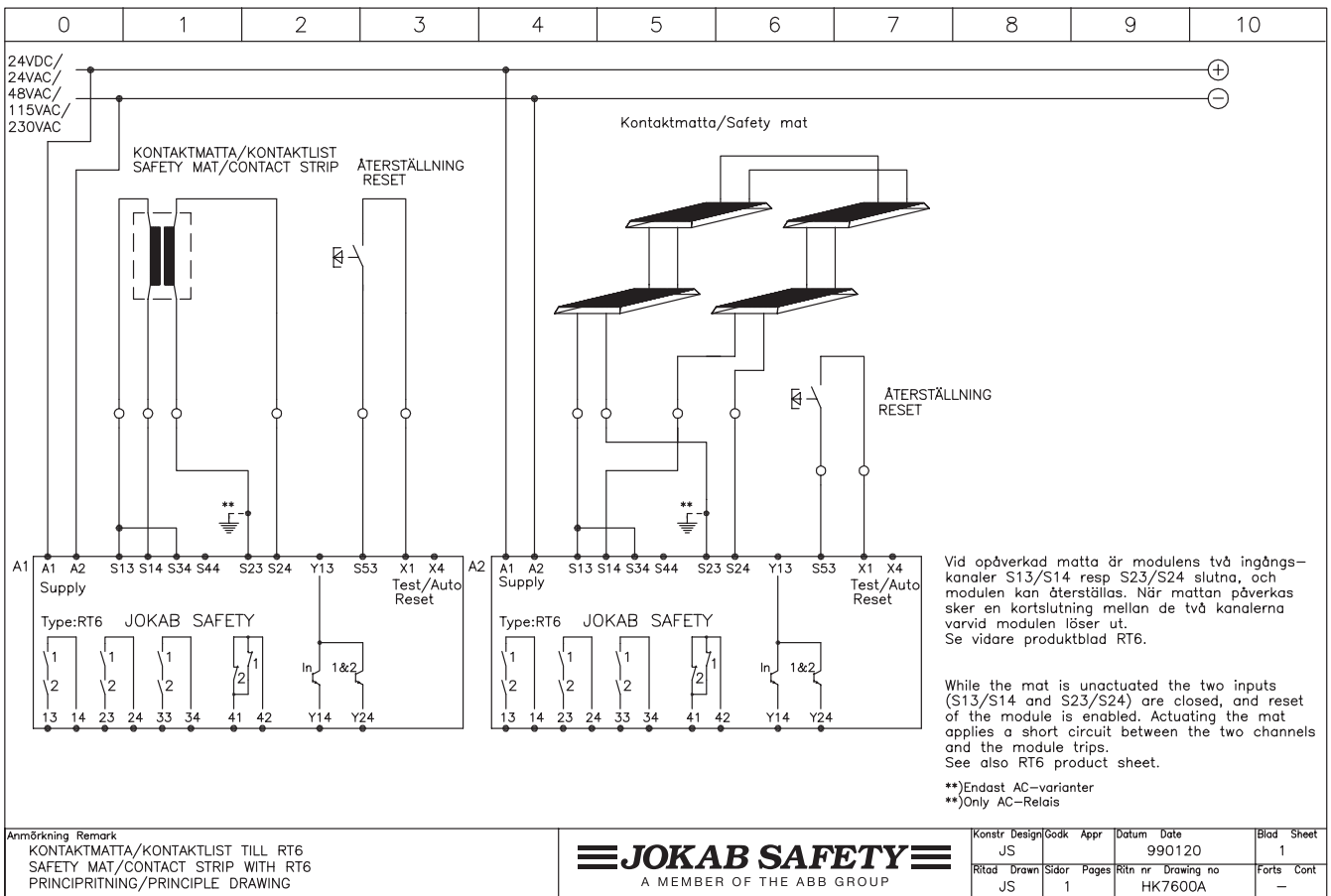

HL7600B Several JSNY7 connected to one RT6 with unique indication

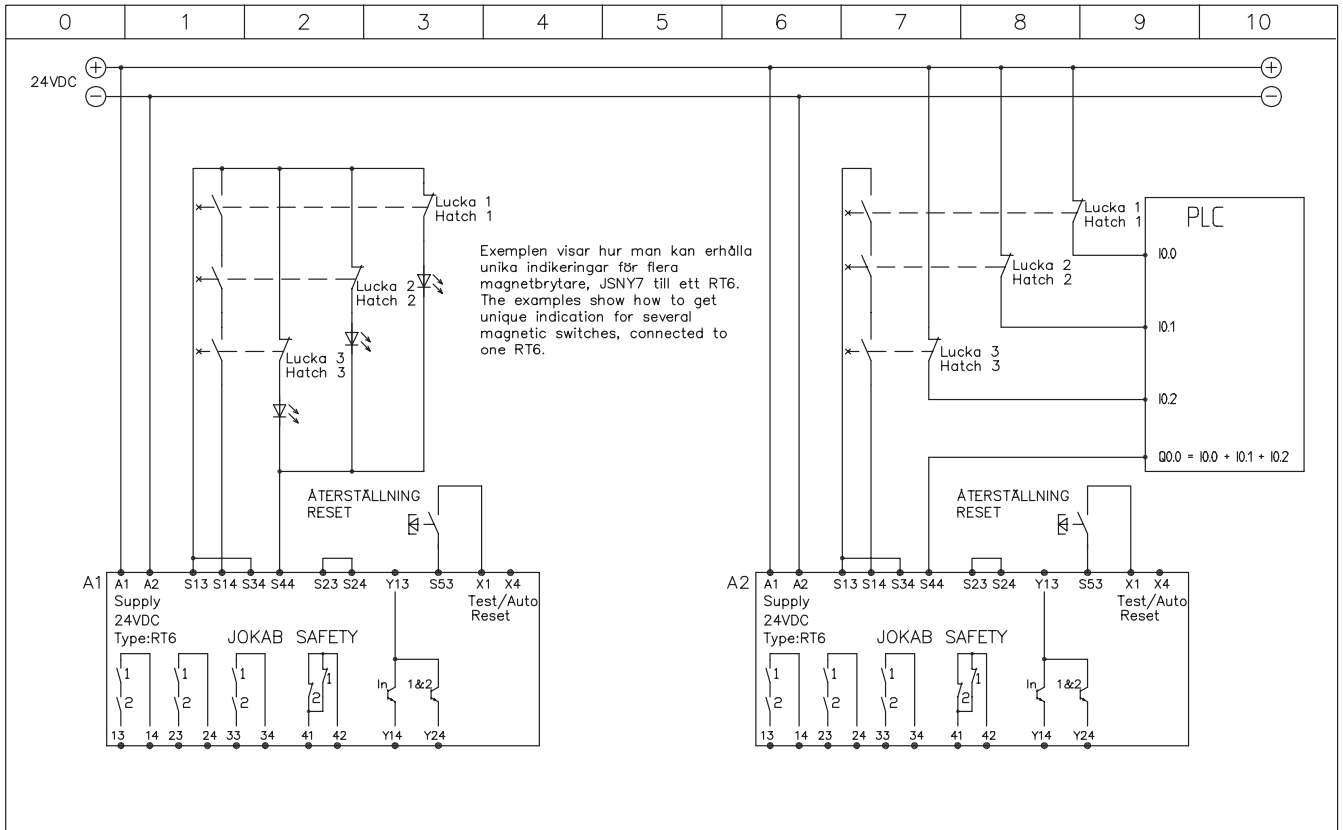

Anmärkning Remark FLERA JSNY7 TILL ETT RT6 MED UNIKA INDIKERINGAR SEVERAL JSNY7 CONNECTED TO ONE RT6 WITH UNIQUE INDICATION	JOKAB SAFETY A MEMBER OF THE ABB GROUP	Konstr Design	Codk	Appr	Datum Date	Blad Sheet
		JS			990120	1
		Ritad Drawn	Sidor Pages	Ritn nr Drawing no	Forts Cont	
		JS	1	HL7600B	-	

It is the user's responsibility to ensure that all control devices are correctly installed, cared for and operated to meet all applicable European, national and local codes/regulations. Specifications subject to change without notice.

HM0000A Magnetic switch JSNY7 with various safety controllers

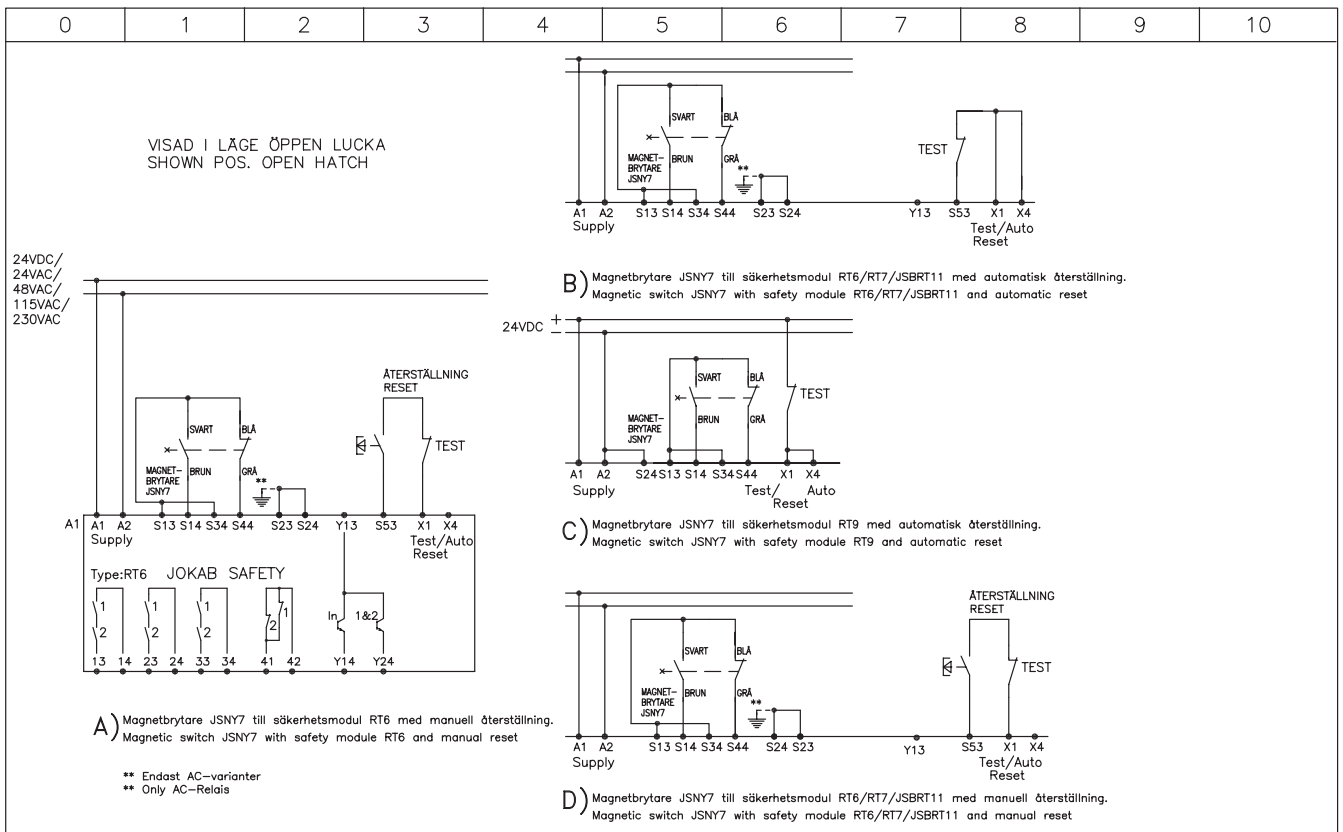

Anmärkning Remark MAGNETBRYTARE JSNY7 TILL OLIKA SÄKERHETSMODULER MAGNETIC SWITCH JSNY7 WITH VARIOUS SAFETY MODULES	JOKAB SAFETY A MEMBER OF THE ABB GROUP	Konstr Design	Codk	Appr	Datum Date	Blad Sheet
		JS			991209	1
		Ritad Drawn	Sidor Pages	Ritn nr Drawing no	Forts Cont	
		JS	1	HMO000A	-	

It is the user's responsibility to ensure that all control devices are correctly installed, cared for and operated to meet all applicable European, national and local codes/regulations. Specifications subject to change without notice.

HN7660A Delayed outputs RT6 with output expansion JSR3T and RT7

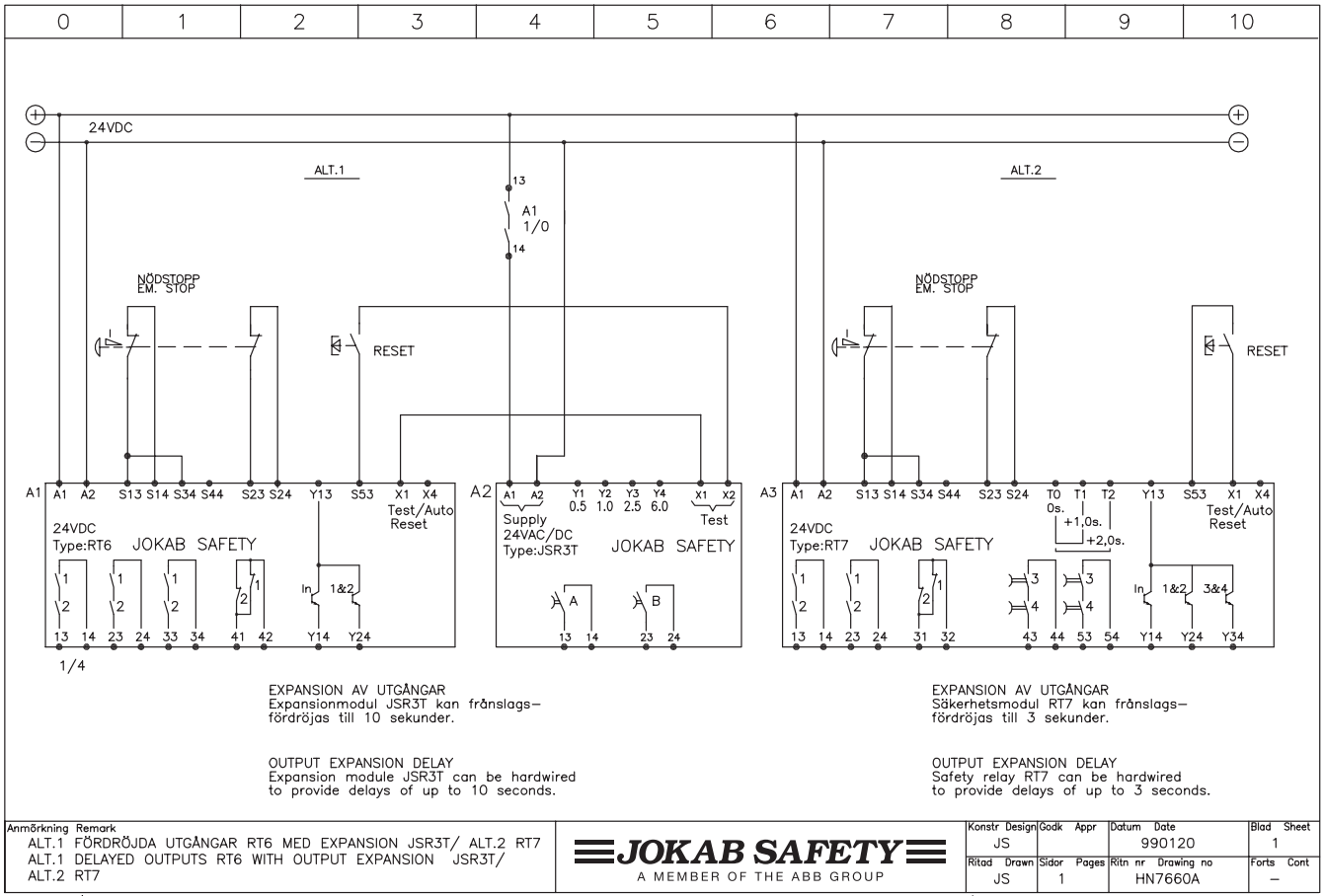

HP7600A Machine control - Isolation of PLC inputs and outputs

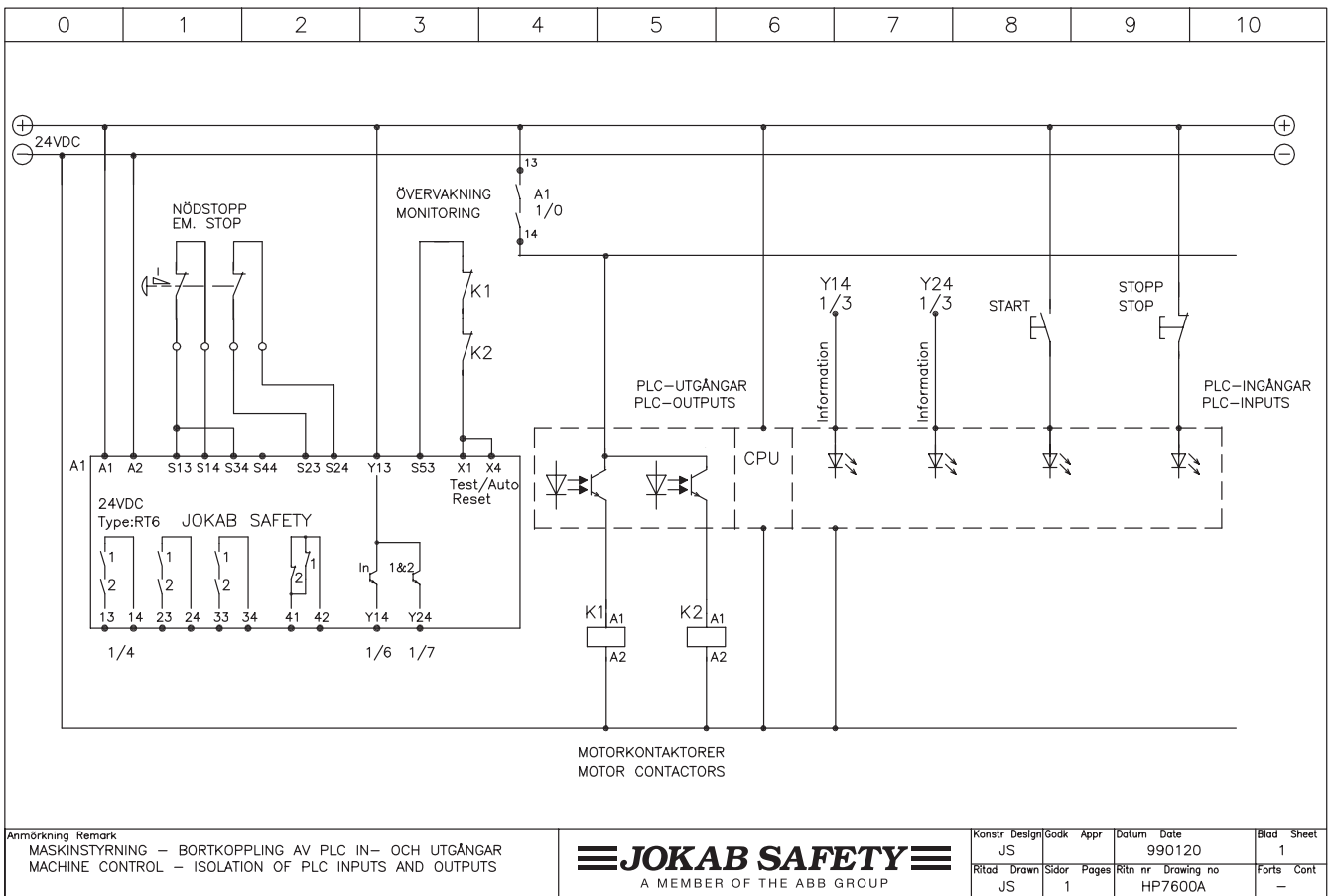

HP7600B Machine control-Isolation of PLC outputs

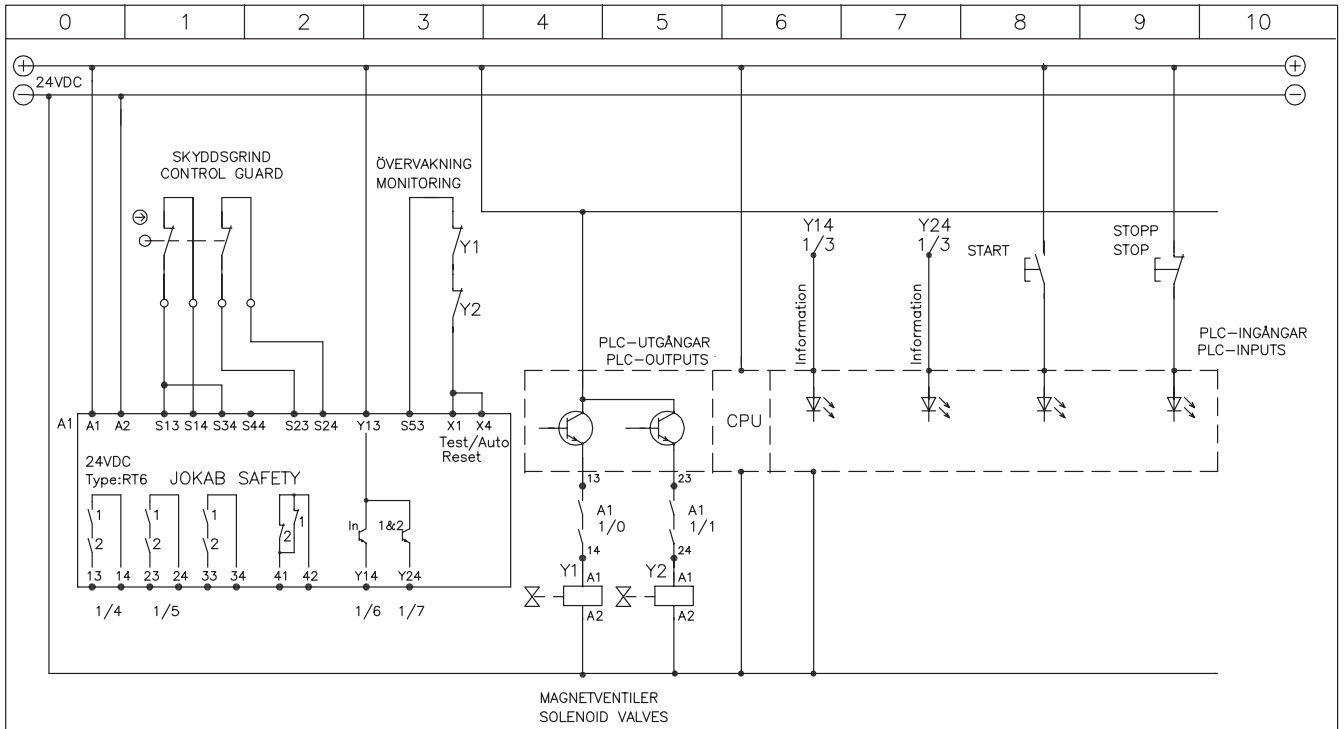

Högriskapplikation t.ex. manuellt betjänade pressar.
High risk application for example manually operated presses.

Anmärkning Remark MASKINSTYRNING - BORTKOPPLING AV PLC-STYRDA UTGÅNGAR MACHINE CONTROL - ISOLATION OF PLC OUTPUTS	JOKAB SAFETY A MEMBER OF THE ABB GROUP				Konstr Design Godk Appr	Datum Date	Blad Sheet
	JS	JS	1	1	990120	1	
					Ritad Drawn Sidor Pages Rittn nr Drawing no	HP7600B	Forts Cont
					JS	1	-

It is the user's responsibility to ensure that all control devices are correctly installed, cared for and operated to meet all applicable European, national and local codes/regulations. Specifications subject to change without notice.

HR7200B Focus light curtain/beam

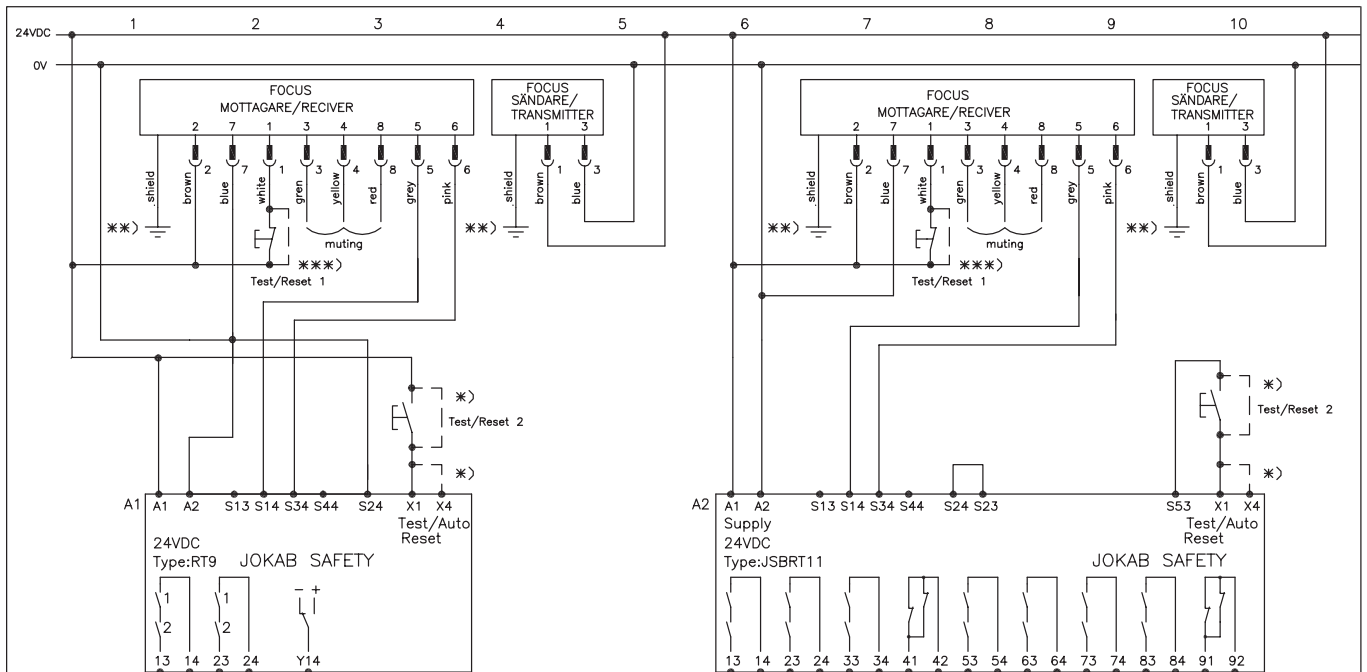

***)Återställning av ljusrädd/ljusbom
För mer information se Focus manual
***)Reset of the Safety Light Curtain/Barrier
For more information se The Focus Manual

*)Automatisk återställning/Automatic reset (säkerhetsrelä/safetyrelays)
**)Skärmen jordas endast i skåpsänden.
***)The cable shield should only be connected at the cabinet end.

Anmärkning Remark FOCUS LJUSRÄDD/LJUSBOM FUCUS LIGHT CURTAIN/BEAM	JOKAB SAFETY A MEMBER OF THE ABB GROUP				Konstr Design Godk Appr	Datum Date	Blad Sheet
	JS	JS	1	1	040311	1	
					Ritad Drawn Sidor Pages Rittn nr Drawing no	HR7200B	Forts Cont
					JS	1	-

It is the user's responsibility to ensure that all control devices are correctly installed, cared for and operated to meet all applicable European, national and local codes/regulations. Specifications subject to change without notice.

HR7800B Focus lightbeam/curtain

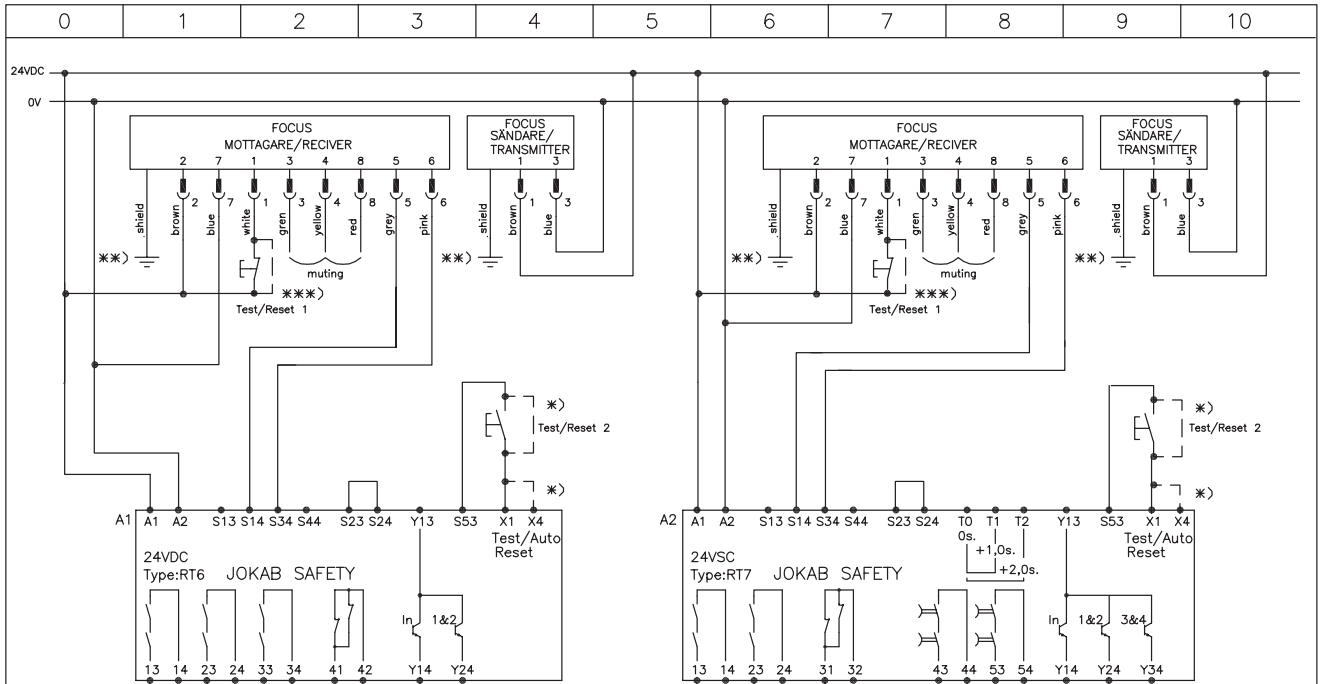

***)Återställning av ljusråd/ljusbom
För mer information se Focus manual
***)Reset of the Safety Light Curtain/Barrier
For more information se The Focus Manual

*)Automatisk återställning/Automatic reset (säkerhetsrelä/safetyrelays)
**)Skärmen jordas endast i skåpsänden.
**)The cable shield should only be connected at the cabinet end.

Anmärkning Remark
FOCUS LJUSBOM/LJUSRIDA
FOCUS LIGHTBEAM/CURTAIN

JOKAB SAFETY
A MEMBER OF THE ABB GROUP

Konstr Design	Gödk	Appr	Datum Date	Blad Sheet
JS			20040831	1
Ritad Drawn	Sidor Pages	Ritn nr Drawing no	Forts Cont	
JS	1	HR7800B		

It is the user's responsibility to ensure that all control devices are correctly installed, cared for and operated to meet all applicable European, national and local codes/regulations. Specifications subject to change without notice.

HT5400A Two-hand device with safety relay JSBR4

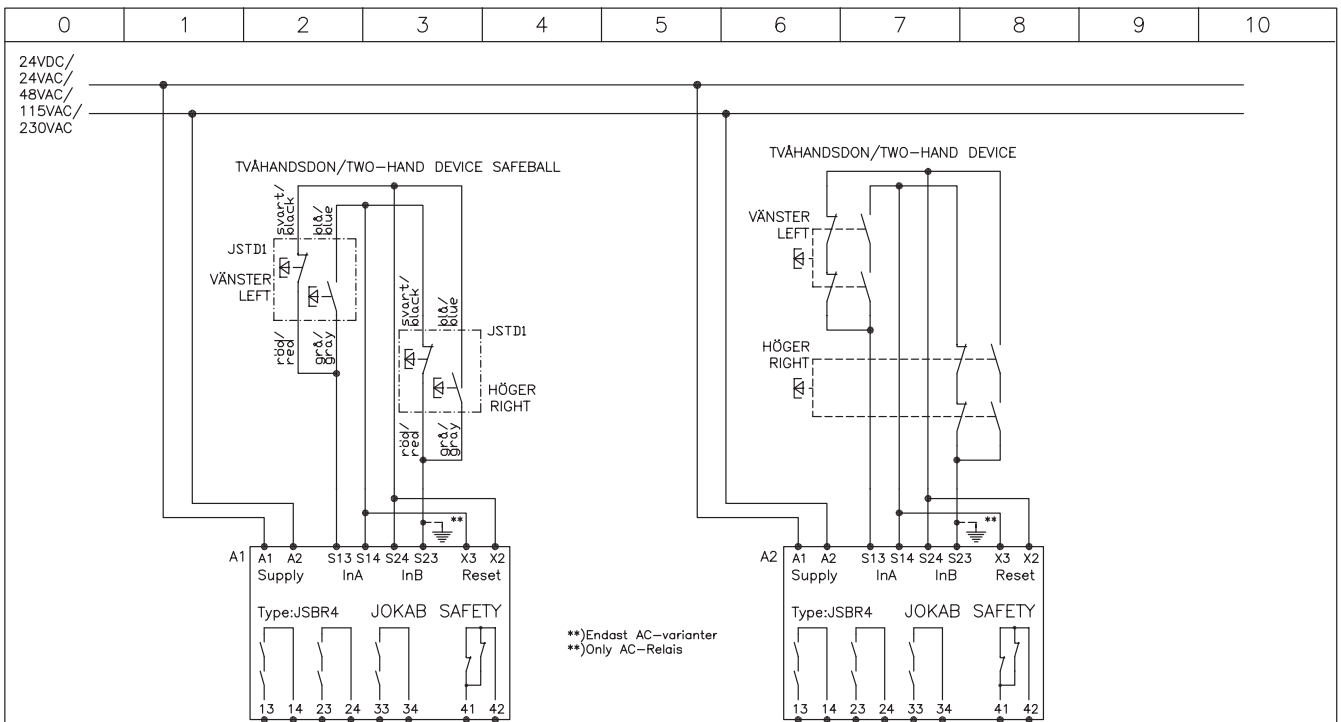

Alt. 1
Tvåhandsdon SAFEBALL med två kontakter per knapp.
Two-hand device SAFEBALL with two contacts in each SAFEBALL.

Alt. 2
Tvåhandsdon JSTD13 av äldre variant eller annat tvåhandsdon med fyra kontakter per knapp.
Two-hand device JSTD13, older type, or other two-hand device with four contacts per push-button.

**Endast AC-varianter
**)Only AC-Relais

Anmärkning Remark
TVÅHANDSDON MED SÄKERHETSRELÄ JSBR4
TWO-HAND DEVICE WIT SAFETY RELAY JSBR4

JOKAB SAFETY
A MEMBER OF THE ABB GROUP

Konstr Design	Gödk	Appr	Datum Date	Blad Sheet
JS			000228	1
Ritad Drawn	Sidor Pages	Ritn nr Drawing no	Forts Cont	
JS	1	HT5400A		

It is the user's responsibility to ensure that all control devices are correctly installed, cared for and operated to meet all applicable European, national and local codes/regulations. Specifications subject to change without notice.

HB0008A Focus light curtain/light beam connected to an RT9 with the aid of a M12-3D

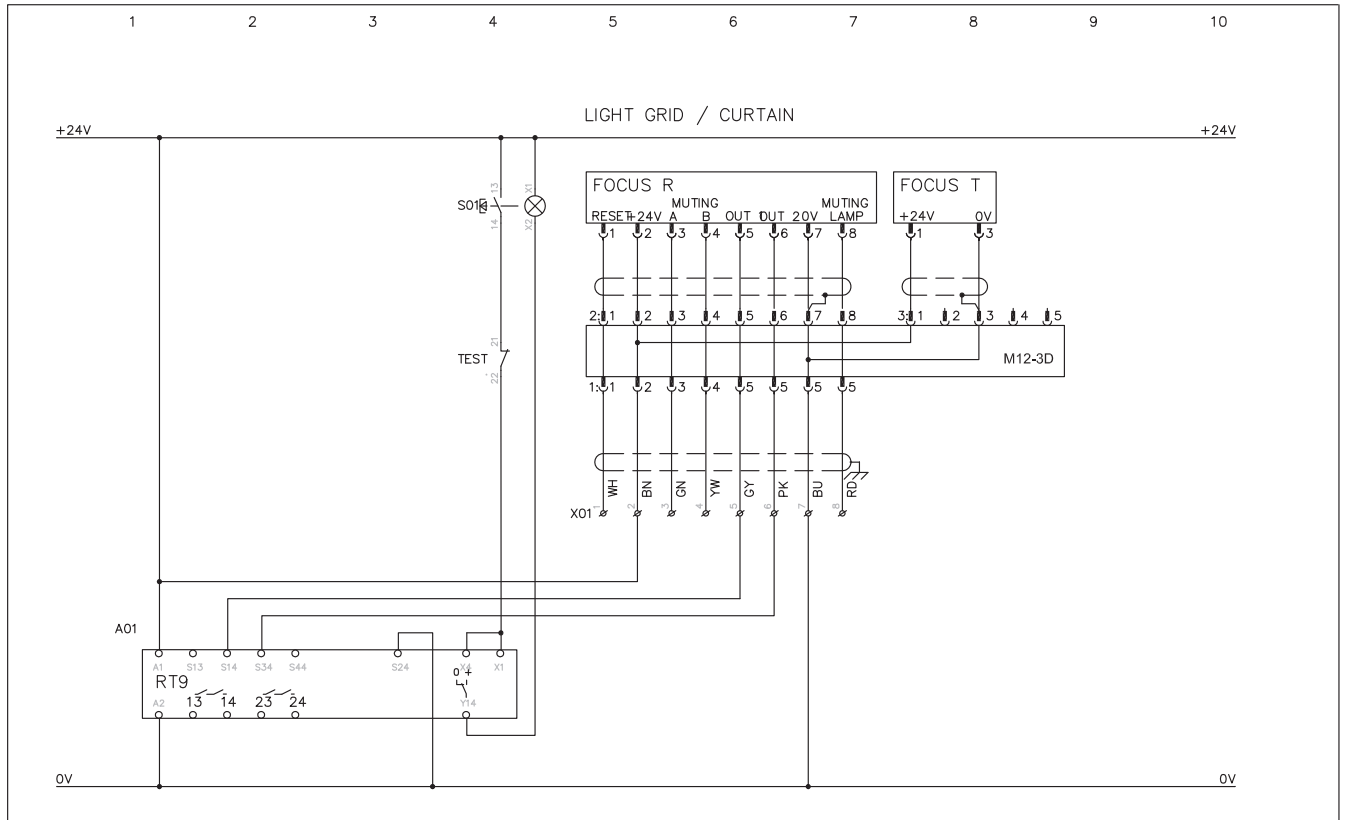

Anmärkning Remark FOCUS WITH M12-3D TO RT9	JOKAB SAFETY A MEMBER OF THE ABB GROUP				Konstr Design	Godk Appr	Datum Date	Blad Sheet
	Ritad Drawn	Sidor Pages	Ritn nr Drawing no	Forts Cont	JS		20080402	

It is the user's responsibility to ensure that all control devices are correctly installed, cared for and operated to meet all applicable European, national and local codes/regulations. Specifications subject to change without notice.