

# Control devices



## Contents

Page

<i>Why should control devices be used?</i> _____	<b>10:2</b>
<i>Three-position devices - JSHD4</i> _____	<b>10:4</b>
<i>Unique world-wide two-hand device - Safeball</i> _____	<b>10:12</b>
<i>Two hand device - JSTD20</i> _____	<b>10:20</b>

While every effort has been taken to ensure the accuracy of information contained in this book and any associated promotional and information material ABB Jokab Safety cannot accept responsibility for errors or omissions and reserves the right to make any improvements without notice. It is the users responsibility to ensure that this equipment is correctly designed, specified, installed, cared for and operated to meet all applicable local, national and international codes/regulations. Technical data in our book is correct to the level of accuracy of ABB Jokab Safety's test procedures as verified by various international approved bodies. Other information (such as application examples, wiring diagrams, operation or use) is intended solely to illustrate the various uses of our products. ABB Jokab Safety does not guarantee or imply that the product when used in accordance with such examples in a particular environment will fulfil any particular safety requirement and does not assume any responsibility or liability for actual use of the product based on the examples given. 2011.

# Control devices

Why should Control Devices be used?

..for the machine operator to be able to directly start and stop dangerous machine movement.



## Three-position device

Three-position devices, hold-to-run devices and enabling devices are used during trouble-shooting, programming and test running when no other safety components are possible or suitable. The device is held in the hand and the operator can in an emergency situation either press harder or entirely release the device to stop the machine.

In an emergency situation the operator can either press harder or release the three-position device to stop the machine.



### **Ergonomic three-position device, JSHD4**

*with double three-position button that gives a stop signal when released or fully pressed in.*



### **Two-channel all the way out to the hand**

*Safeball is an ergonomic two-hand control device with four built-in buttons.*

## **Two-hand control device**

A two-hand control device is used when it must be guaranteed that the operator's hands will be kept outside the risk area. If there is a risk that someone else other than the operator can reach into the machine without the operator seeing it, the safety device must be supplemented by something more, e.g. a light beam.

To be able to operate the machine with the two-hand device, all the buttons on the device have to be operated within 0.5 seconds of each other. This is called concurrence. All the buttons also have to be returned to their initial position before one can start again. If any button is released during the machine movement the machine will be stopped. Using the stopping time one can calculate the necessary safety distance. A safety distance of less than 100 mm must not be used.

The highest safety level is assured by connecting the buttons of the two-hand device to a safety relay. The safety relay checks for concurrence and that all the buttons have returned to their initial position before a new start can be made. The safety relay also gives a stop signal if any of the buttons are released.

**The two-hand device protects against "after-grasp"; if the operator by reflex tries to enter or reach into a machine during the dangerous machine movement.**



**Safety foot operated switch** with three-position function.

**The foot operated switch is used when the operator has to hold the material with both hands during processing.**

## **Foot operated switches**

A foot operated switch is used when the operator has to hold the material during processing. The pedal must have a safety cover to prevent unintentional start. For seated work one must also have a foot support to facilitate the operator holding his foot in the pedal's off position.

The highest safety level is secured by monitoring the pedal with a safety relay.

# Three position device

# JSHD4

## Approvals:



## Use:

Troubleshooting  
Test running  
Programming

## Advantages:

Ergonomic  
LED information  
Adaptable  
Cheat Safe  
Adapted for AS-i



## The safest solution during trouble shooting, programming and testing

### Why three-positions?

An operator who is under pressure must be able to give a stop signal, whether in panic he/she pushes harder on the button or just lets go of it.

Three-position devices, hold-in and acceptance devices can be used for trouble shooting, programming and test running in situations where no other protection is available or feasible.

If the operator has to enter a risk area to trouble shoot or run a test, it is extremely important that he/she is able to stop the machinery without having to rely on someone else to stand by a stop button that is further away. In addition, no-one else should be able to start the machinery from the outside after it has been stopped by use of the three-position device.

### Hold to run device or Acceptance device, what is the difference?

**Hold to run device:** The start signal is given when the button is pressed. The stop signal is given when the button is released or pushed fully in.

**Acceptance device:** The start signal for separate starting is given when the button is pressed. The stop signal is given when the button is released or pushed fully in. "Separate start" means, for example, that a program start signal is sent to the robot via a separate button in the acceptance device.

### The three-position device is designed to be ergonomic

The device is ergonomic, both in respect of its shape, fitting to the hand, and the way the buttons are operated. It is easy to operate the three-position device using just the fingers, and the middle position provides a secure resting position. The device has LED indications that show the operational status, i.e. stop or ready signal. The two additional buttons can be used, for example, for start/stop, up/down or forward/back. Internally the device is duplicated. The three-position function itself is built up of two completely independent three-position buttons which are felt by the user to be one button.

### Cheat Safe three-position device with hand recognition

The three-position device JSHD4 has sensors which ensure that it is a human hand holding it. By using this, the safety level is increased, and the risk of manipulation or bypass of the safety function is reduced. It is no longer possible to expose the operator or odder to danger by trying to lock the three-position device in run mode.

### Three-position device adapted for AS-i

The three-position device JSHD4 also comes in a version adapted for direct attachment to the AS-i bus

## Highest safety level whether the button is pushed or released

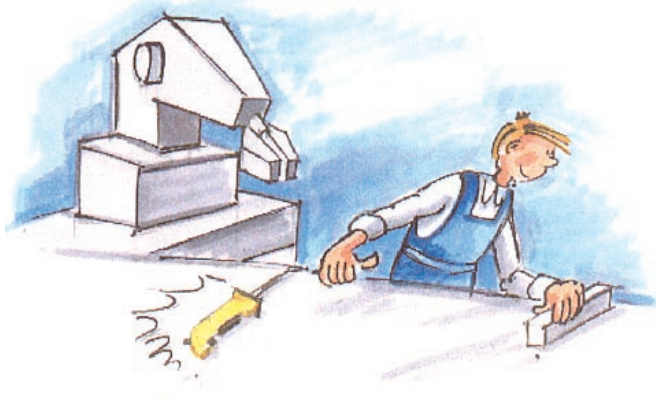

When the three-position button is released you will obtain a dual stop. It is essential that the machine stops when you put aside the three-position device, for example during adjustment.



When the three position button is pushed all the way in you will obtain a dual stop. It is essential that the machine stops in an emergency situation.

### How does a a three-position device work?

#### Safety level

A safe Enabling or Hold to Run device should function as follows:

1. The Stop signal in released (top) and bottom position shall have the same safety level.
2. Provide a 'Start' or 'Ready' signal in a distinct middle position.
3. After a 'Stop' in the bottom position, a 'Start' signal or 'Ready' signal is not permitted until the three position push-buttons have been totally released and again pressed to the middle position. This function is achieved mechanically within the three position push-buttons in the device.
4. A Short or Open circuit in the connection cables shall not lead to a dangerous function e.g. 'Start' or 'Ready' signal.

In order to meet the above conditions, the three-position switch must be connected to a suitable safety relay with a two channel function, e.g. RT6, RT9 or JSBT4, which can monitor that both three-position buttons are working and

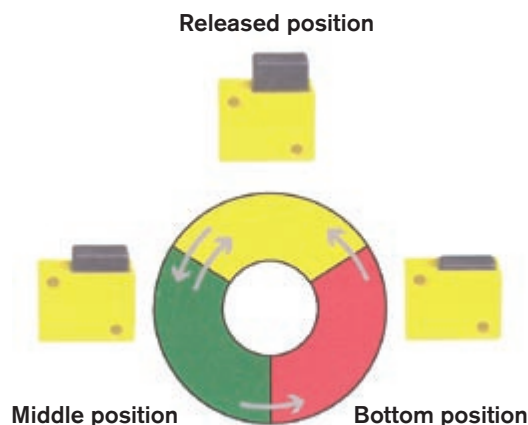

that there is no short or open circuit in the connection cable or the switch.

#### Regulations and standards

The JSHD4 is designed and approved in accordance with appropriate directives and standards. See technical data.

### Three-position devices in different versions



Three-position device fitted to a machine control unit.



Panel assembly of JSHD4H2 on a programming unit for robots.



## Design a three-position device for your needs

### 1. Choose between five different top units



**JSKD4-1**  
2TLJ020006R2100



**JSKD4-2**  
2TLJ020006R2200  
▪ LEDs  
▪ Front button  
▪ Top button



**JSKD4-3**  
2TLJ020006R2300  
▪ LEDs



**JSKD4-4**  
2TLJ020006R2400  
▪ LEDs  
▪ Front button



**JSKD4-5**  
2TLJ020006R2500  
▪ LEDs  
▪ Top button

### 2. Choose a bottom part suitable for your assembly



**AA, AH, AJ**



**AB**



**AC, AD**



**AF, AG**



**AE**

**AA** – 2TLJ020005R1000 with cable gland  
**AB** – 2TLJ020005R1100 with Cannon connection  
**AC** – 2TLJ020005R1200 with M12 connection (5 poles)  
**AD** – 2TLJ020005R1300 with M12 connection (8 poles)  
**AE** – 2TLJ020005R1400 with M12 connection (8 poles) and emergency stop

**AF** – 2TLJ020005R1500 with M12 connection (4 poles) and 2 AS-i nodes (for front and top button)  
**AG** – 2TLJ020005R1600 with M12 connection (4 poles) and 1 AS-i node (without front and top button)  
**AH** – 2TLJ020005R1700 with cable gland and PCB with 10 screw connections  
**AJ** – 2TLJ020005R1800 with cable gland and PCB with 16 screw connections

### 3. Choose hand recognition for making your three position device cheat protected (option)

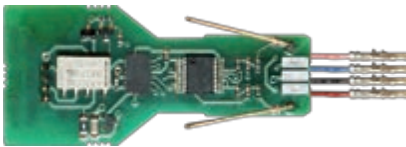

**Anti-tamper PCB** – 2TLJ020005R0900

### 4. Check the table if your combination is available

### 5. Choose a bottom plate (option)

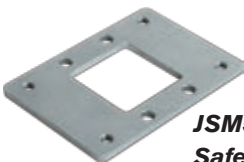

**JSM50G, bottom plate for Safety Interlock switch JSNY5** – 2TLJ020205R6300



**JSM50H, bottom plate for non-contact sensor Eden (Eva)** – 2TLJ020205R6400

## Available combinations of bottom- and top parts

	JSHD4-1	JSHD4-2	JSHD4-3	JSHD4-4	JSHD4-5
AA without Cheat Safe	JSHD4-1AA	-	-	-	-
AA with Cheat Safe	-	-	-	-	-
AB without Cheat Safe	-	JSHD4-2AB	JSHD4-3AB	JSHD4-4AB	JSHD4-5AB
AB with Cheat Safe	-	JSHD4-2AB-A	JSHD4-3AB-A	JSHD4-4AB-A	JSHD4-5AB-A
AC without Cheat Safe	JSHD4-1AC	-	-	-	-
AC with Cheat Safe	-	-	-	-	-
AD without Cheat Safe	-	JSHD4-2AD	JSHD4-3AD	JSHD4-4AD	JSHD4-5AD
AD with Cheat Safe	-	JSHD4-2AD-A	JSHD4-3AD-A	JSHD4-4AD-A	JSHD4-5AD-A
AE without Cheat Safe	-	-	JSHD4-3AE	-	-
AE with Cheat Safe	-	-	-	-	-
AF without Cheat Safe	-	JSHD4-2AF	JSHD4-3AF	JSHD4-4AF	JSHD4-5AF
AF with Cheat Safe	-	JSHD4-2AF-A	JSHD4-3AF-A	JSHD4-4AF-A	JSHD4-5AF-A
AG without Cheat Safe	-	-	JSHD4-3AG	-	-
AG with Cheat Safe	-	-	-	-	-
AH without Cheat Safe	-	JSHD4-2AH	JSHD4-3AH	JSHD4-4AH	JSHD4-5AH
AH with Cheat Safe	-	JSHD4-2AH-A	JSHD4-3AH-A	JSHD4-4AH-A	JSHD4-5AH-A

## Order your pre-assembled three position device from ABB Jokab Safety

Pre-assembled three position devices	
2TLJ019995R0000	JSHD4-1AA
2TLJ019995R0100	JSHD4-1AC
2TLJ019995R0200	JSHD4-2AB
2TLJ019995R0300	JSHD4-2AB-A
2TLJ019995R0400	JSHD4-2AD
2TLJ019995R0500	JSHD4-2AD-A
2TLJ019995R0600	JSHD4-2AF
2TLJ019995R0700	JSHD4-2AF-A
2TLJ019995R0800	JSHD4-2AH
2TLJ019995R0900	JSHD4-2AH-A
2TLJ019995R1200	JSHD4-3AB
2TLJ019995R1300	JSHD4-3AB-A
2TLJ019995R1400	JSHD4-3AD
2TLJ019995R1500	JSHD4-3AD-A
2TLJ019995R1600	JSHD4-3AE
2TLJ019995R1700	JSHD4-3AF
2TLJ019995R1800	JSHD4-3AF-A
2TLJ019995R1900	JSHD4-3AG
2TLJ019995R2000	JSHD4-3AH
2TLJ019995R2100	JSHD4-3AH-A
2TLJ019995R2400	JSHD4-4AB
2TLJ019995R2500	JSHD4-4AB-A
2TLJ019995R2600	JSHD4-4AD
2TLJ019995R2700	JSHD4-4AD-A
2TLJ019995R2800	JSHD4-4AF
2TLJ019995R2900	JSHD4-4AF-A
2TLJ019995R3000	JSHD4-4AH
2TLJ019995R3100	JSHD4-4AH-A
2TLJ019995R3400	JSHD4-5AB
2TLJ019995R3500	JSHD4-5AB-A
2TLJ019995R3600	JSHD4-5AD
2TLJ019995R3700	JSHD4-5AD-A
2TLJ019995R3800	JSHD4-5AF
2TLJ019995R3900	JSHD4-5AF-A
2TLJ019995R4000	JSHD4-5AH
2TLJ019995R4100	JSHD4-5AH-A

Accessories	
2TLJ020055R1000	Connectors: M12-C01 M12 5-pole female, straight
2TLJ020055R1600	M12-C03 M12 8-pole female, straight
2TLJ020003R0300	JSHK0 12-pole connector for JSHD4
2TLJ020057R0000	Cable with 5 conductors: C5 Cable 5x0,34 cut to length
2TLJ020056R1000	M12-C101 10 m cable and connector
2TLJ020056R1400	M12-C201 20 m cable and connector
2TLJ020057R1000	Cable with 8 conductors: C8 Cable 8x0,34 cut to length
2TLJ020056R4000	M12-C103 10 m cable and connector
2TLJ020056R4100	M12-C203 20 m cable and connector
2TLJ020003R5500	Cable with 12 conductors: HKC12 Cable 12x0,25 cut to length
2TLJ020003R4700	HK5 Cable 5 m and connector
2TLJ020003R4800	HK10 Cable 10 m and connector
2TLJ020003R4900	HK20 Cable 20 m and connector
2TLJ020003R5000	JSHK16S4 spiral cable 1,6 m and connector
2TLJ020003R5100	JSHK20S4 spiral cable 2,0 m and connector
2TLJ020003R5200	JSHK32S4 spiral cable 3,2 m and connector
2TLJ020003R3500	JSHK40S4 spiral cable 4,0 m and connector
2TLJ020003R3600	JSHK3604 spiral cable 6,0 m and connector
2TLJ020003R5300	JSHK80S4 spiral cable 8,0 m and connector
2TLJ020003R5400	HK-T2 Cable drum and connector
2TLJ040005R0500	Brackets: JSM55 Wall bracket for three position device
2TLJ040005R0700	JSM5B Wall bracket for 2 JSNY5 (ordered separately)
2TLJ020200R4600	Others: JSHD4 protection coat



## Three-position devices for different types of montage

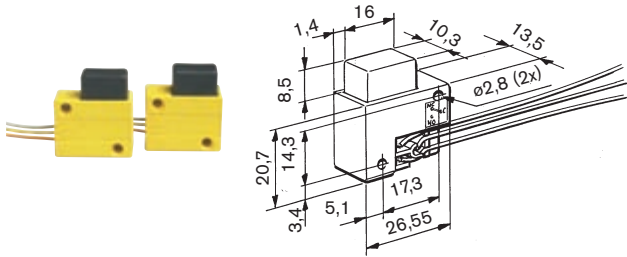

### Three-position push button JSHD2C

The button is the main component in a safe three-position solution. To achieve the highest safety level two buttons are used in a two-channel system.

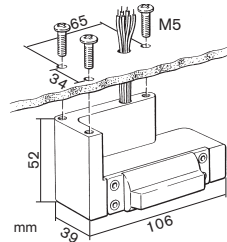

### External assembly JSHD4H2A

The external assembly is similar to the panel assembly unit, although it is a 'handle' design making it suitable for assembly on the outside of a control box.

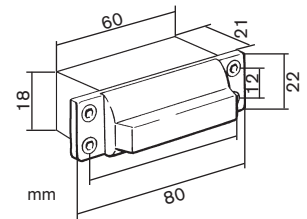

### Panel assembly JSHD4H2

A panel assembly suitable for building into programming units or similar control boxes. Provides simultaneous activation of both of the three-position buttons.

#### Standard versions

2TLJ020002R0200	JSHD4H2A Three-position device for external panel assembly
2TLJ020002R0700	JSHD4S2 Three-position device, ABB upgrading kit
2TLJ020002R3100	JSHD4H2 Three-position device for internal panel assembly
2TLJ020001R1000	JSHD2C type E Three-position button
2TLJ020001R1300	JSHD2C type K Three-position button

Complete JSHD4 with standard options are available to order separately

### Technical data - JSHD4

<b>Manufacturer</b>	ABB AB/Jokab Safety, Sweden
<b>Safety level</b> EN ISO 13849-1	Category 4/PL e
<b>Electrical contact ratings</b> Three-position button:	30 VDC, max 0.5 A (min. 10 mA, 10V)
Extra button:	50 VAC/DC max 0.2 A
<b>Protection class</b>	IP 65
<b>Operating temperature</b>	-10 to +50° C
<b>Function indication</b> Three-position buttons ready signal:	'Yes', green LED 'No', red LED
<b>Material</b>	Polyamide 6.6
<b>Insulation resistance</b>	min 20 M Ohm
<b>Operation force</b>	approx. 15 N
<b>Mechanical life</b>	1 000 000 cycles to middle position
<b>Conformity</b>	AFS 1994:48, EN ISO 12100-1/-2, EN 954-1/EN ISO 13849-1

Pin	Color STD	Color JSHK-S
A	White	White
B	Brown	Brown
C	Green	Green
D	Yellow	Yellow
E	Grey	-
F	Pink	Grey
G	Blue	Pink
H	Red	Blue
I	Black	Red
J	Purple	-
K	-	-
L	-	-

STD: JSHK, JSHK-E, JSHK-T

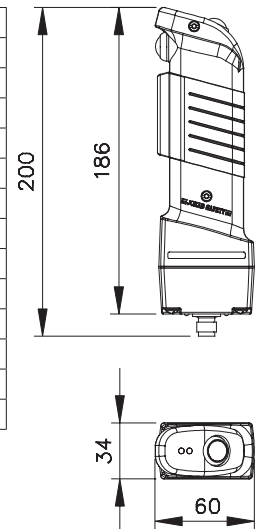

Cable, available in different lengths.



JSHD4 protection coat



Spiral cable, available in different lengths.



JSHK0 12 pole connector for JSHD4.



JSM5B Wall bracket for interlock switches and three-position device.



JSM55 Wall bracket for three-position device.



Cable drum

## Connection example - Three-position device JSHD4 to Pluto

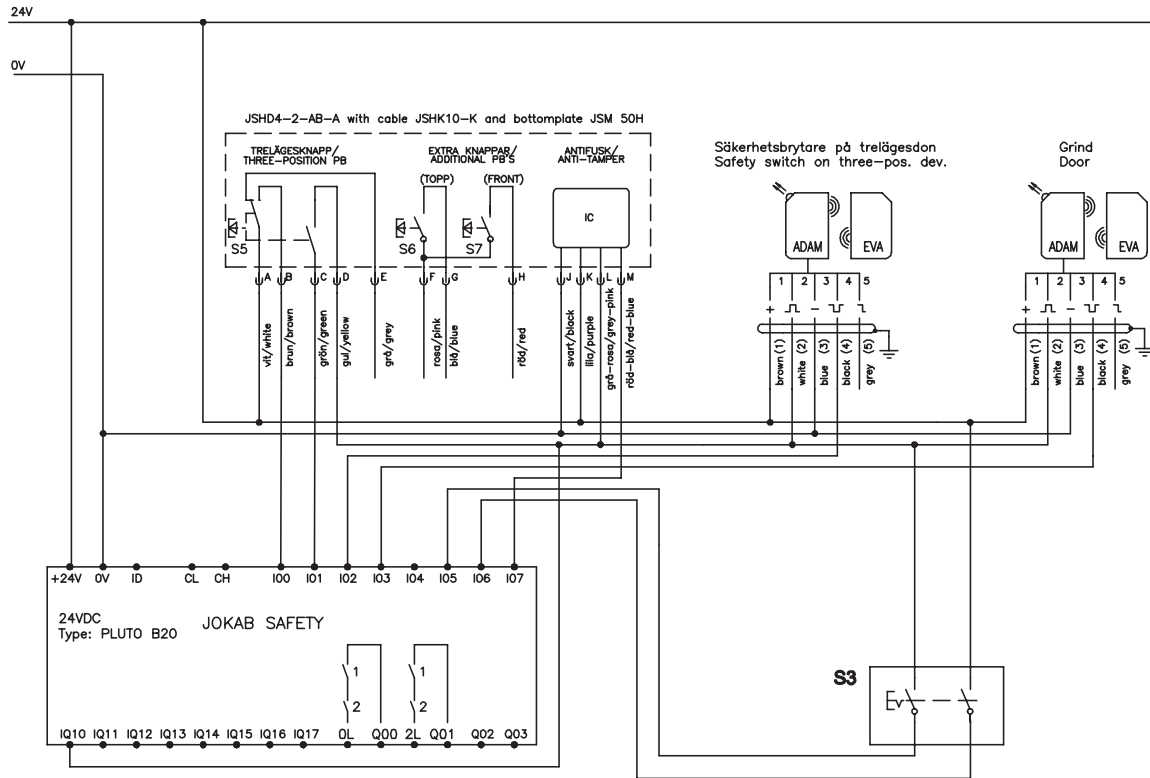

### Time-limited entrance/exit

After lifting the three-position device out of its holder JSM54A, the interlocked gate can be passed for entrance into the risk area within x sec. The time limit is set in the Pluto program. The device detects the operators hand and prohibits tampering.

## Connection examples - Three-position device JSHD4 with various safety controllers

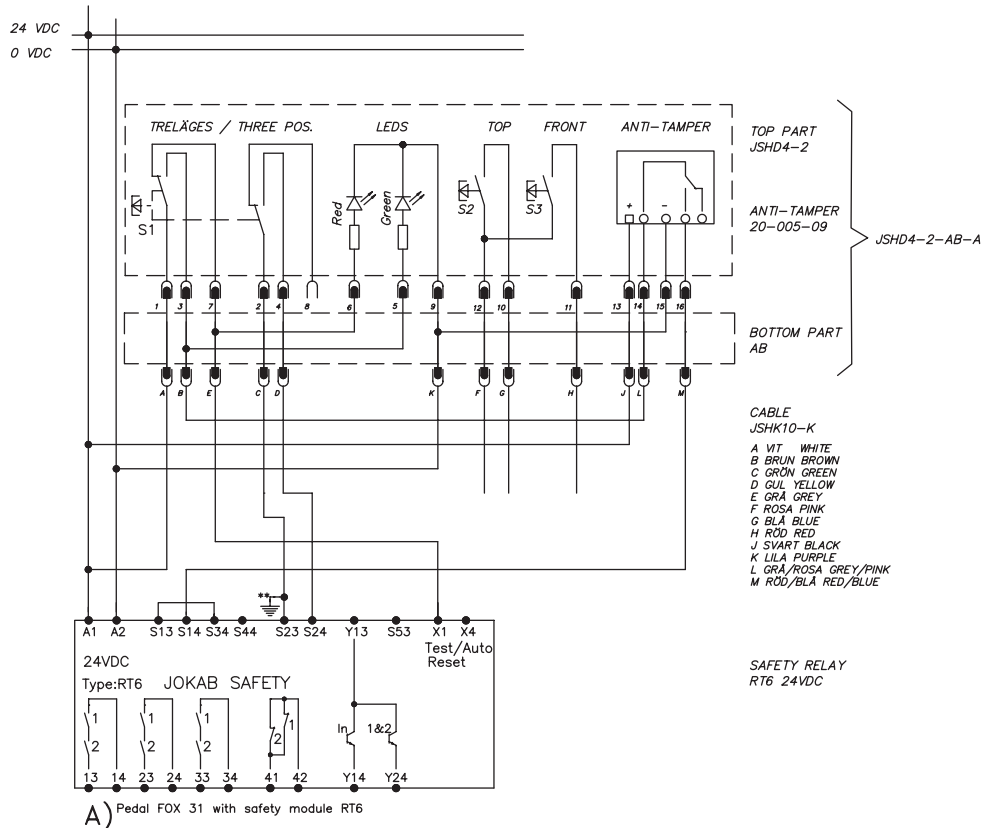

## Connection with bottom parts AB

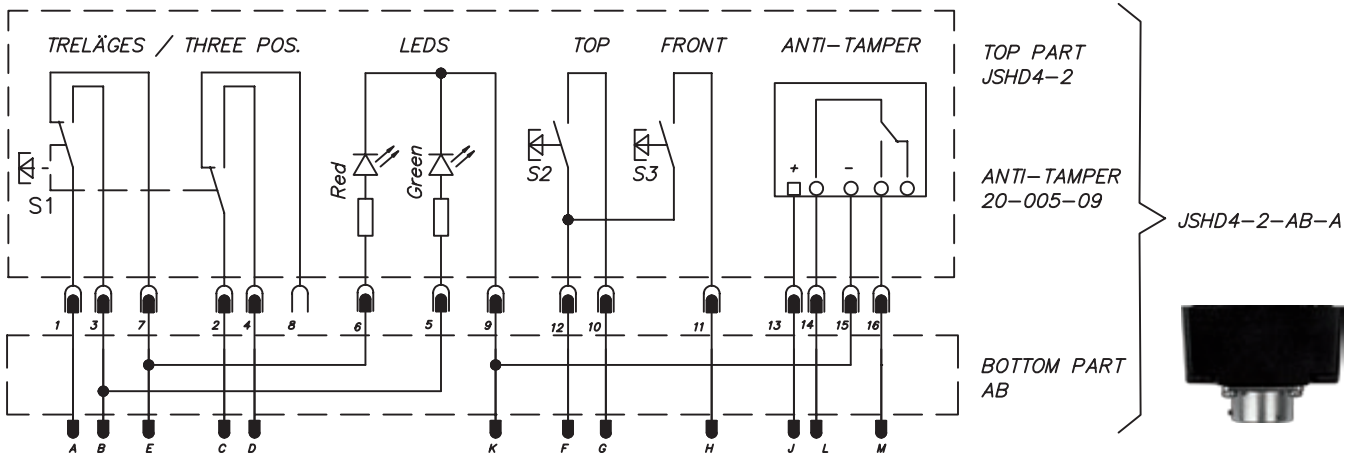

## Connection with bottom parts AC

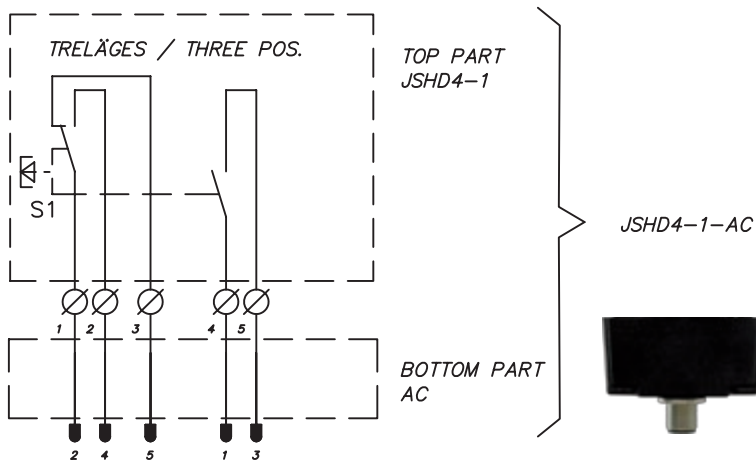

## Connection with bottom parts AD

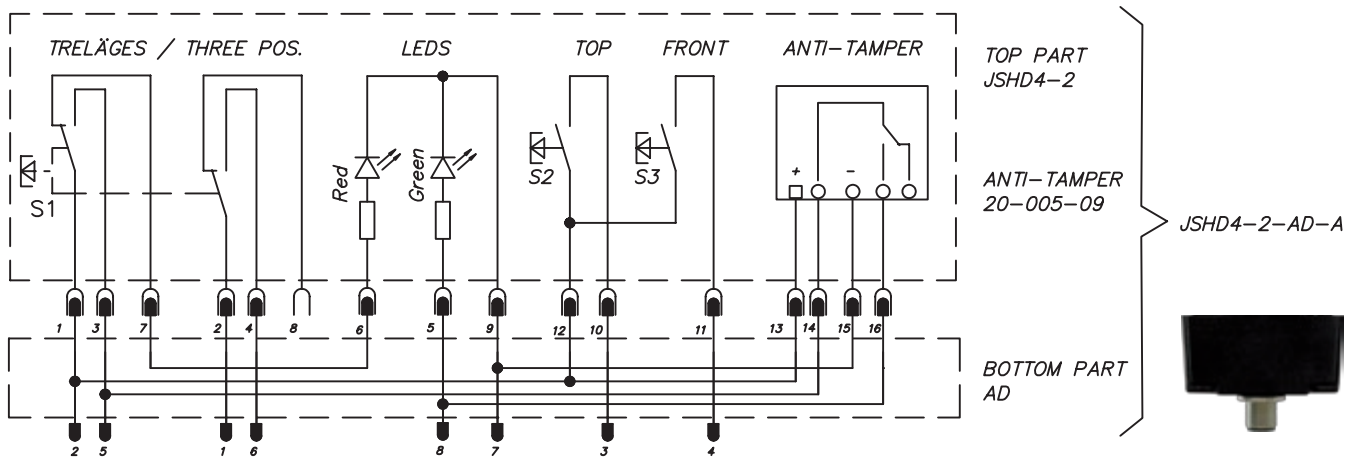

## Connection with bottom parts AE

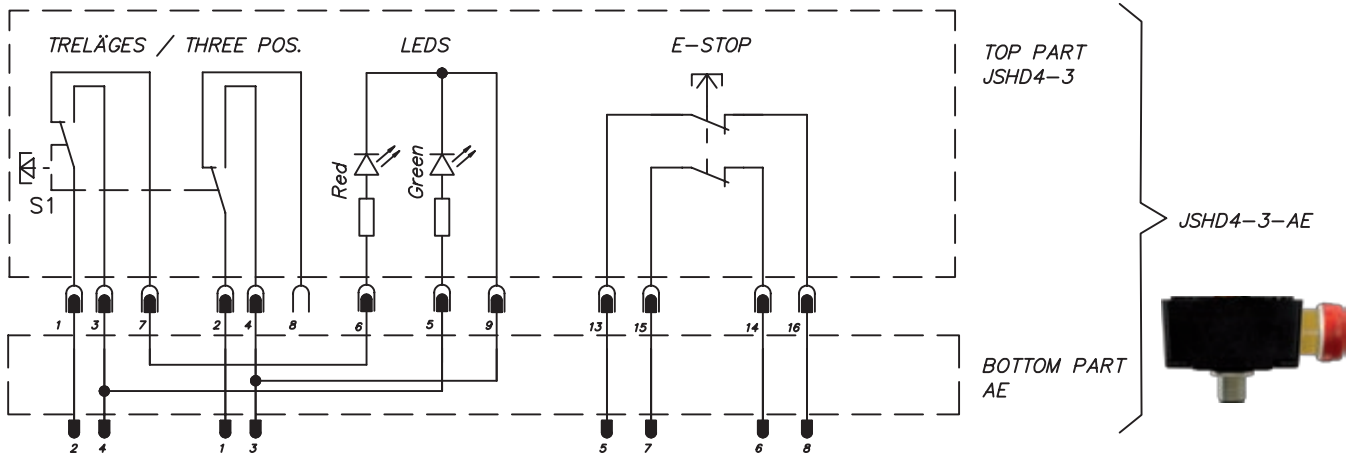

## Connection with bottom parts AH

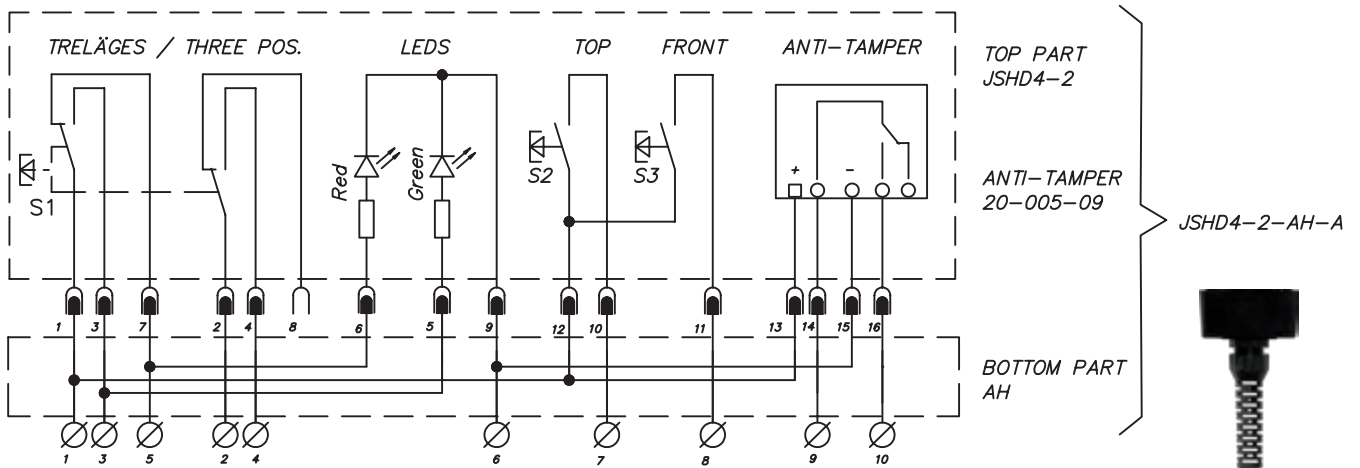

## Connection with bottom parts AJ

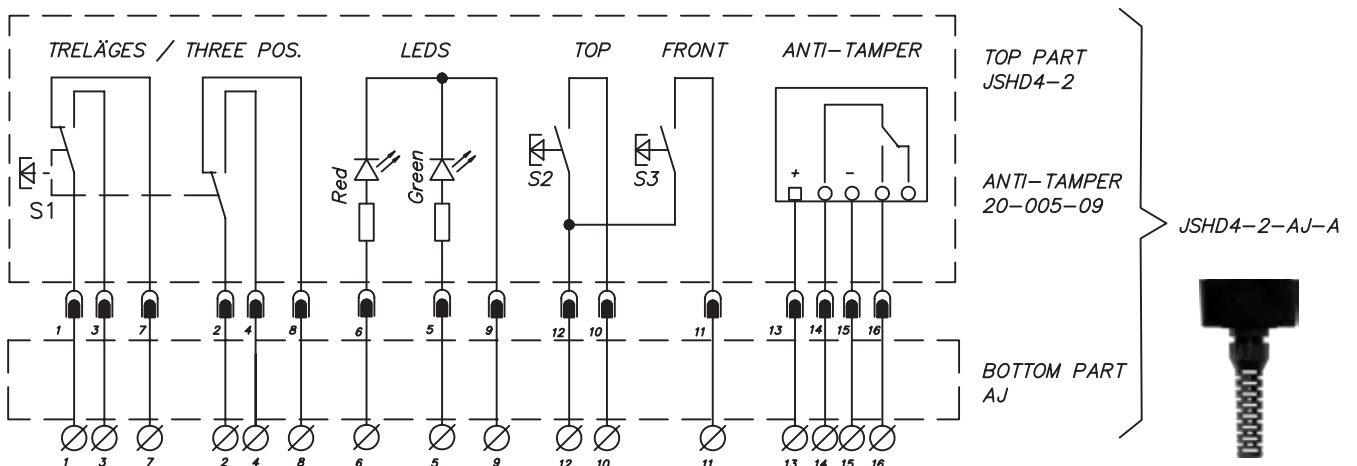

# One and two hand devices

# Safeball™



*A two hand device which is comfortable and easy to use.*



## Approvals:



## Safeball for:

- Presses
- Punches
- Fixtures
- Shearing machines

## Features:

- Ergonomic
- Low activation force
- Flexible mounting
- Several grip possibilities
- Highest safety level
- Two channel switching in each hand

## SAFEBALL™

### Unique World Wide Two hand device

Safeball™ consists of a spherical ball containing two embedded pushbutton switches, one on each side of the ball. By using this pushbutton configuration, the risk of unintentional activation is minimised and the device is simple and ergonomic to use.

Safeball™ can be utilised for either One hand (one Safeball™) or Two hand (two Safeballs™) applications. In either application, and in order to meet the required level of safety, the Safeball™ switches are monitored by specified/certified ABB Jokab Safety Safety relays (see electrical connection).

In the case where Two hand control is used, both Safeballs™ i.e. all four pushbuttons have to be activated within 0.5 seconds. If one or more pushbuttons are released a Stop signal is given to the machine. In order to provide the highest level of safety the Safeball™ design provides the operator with a dual switching function and short-circuit supervision in each hand.

Each Safeball™ is ergonomically designed and has both its cover and actuator made of environmentally-friendly polypropylene. The design allows for comfort of use for all hand sizes and operation from numerous gripping positions. Mounting of the Safeball™ is also very flexible allowing the device to be mounted in the most ergonomic position for the operator.

### When can a Two hand or One hand control be used ?

A Two hand control can be used when it is necessary to

ensure that the operator is outside and must be prevented from reaching into the hazardous area. If the operator decides, after the start signal has been given to the machine, to make an 'after-grasp' i.e. try to adjust the part that has been placed into the machine, then a dual stop signal is given to the machine.

A one hand control device can be used when the operator cannot reach the hazardous area with his/her free hand or on less dangerous machines.

### Highest Safety Level

The Safeball™ is certified by Inspecta in Sweden for use as a Two hand control device, when used with a JSBR4 ABB Jokab Safety Safety relay or Pluto Safety-PLC, in accordance with the highest safety level in standard EN 574 (type IIIc).

### Two hand device adapted for AS-i

The two hand device, Safeball also comes in a version adapted for direct attachment to the AS-i bus.

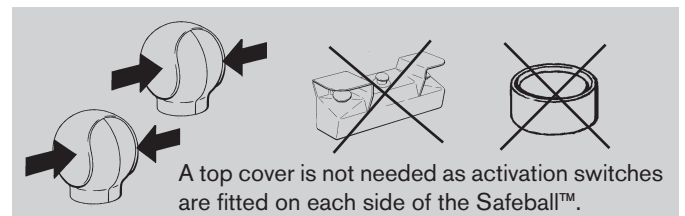

A top cover is not needed as activation switches are fitted on each side of the Safeball™.

Technical data - Safeball	
<b>Manufacturer:</b>	ABB AB/Jokab Safety, Sweden
<b>Article number/Ordering data:</b>	
JSTD1-A Safeball 1 NO + 1 NC with 2 m cable	2TLJ020007R3000
JSTD1-B Safeball Safeball 1 NO + 1 NC with 0.2 m cable	2TLJ020007R3100
JSTD1-C Safeball 1 NO + 1 NC with 10 m cable	2TLJ020007R3200
JSTD1-E Safeball 2 NO 0,2 m cable	2TLJ020007R3400
<b>Material:</b>	Polypropylene
<b>Colour:</b>	Yellow and black
<b>Size:</b>	Height: approx. 71 mm, Diameter, min.: 68 mm Diameter, max.: 72 mm Diameter, base: 42 mm
<b>Weight:</b>	0.2 kg with 2 m cable 0.7 kg with 10 m cable 0.1 kg with 4x0.2 m wires
<b>Safety level:</b>	
EN ISO 13849-1	Up to category 4/PLe
EN 954-1	Up to category 4
<b>Temperature:</b>	0°C to +55°C (operating) -20°C to +70°C (storage)
<b>Protection class:</b>	IP67. Not intended for use under water
<b>Operating force:</b>	Approx. 2 N
<b>Actuator travel:</b>	1.3 +/- 0.6 mm
<b>Max switching load:</b>	30 V 2A DC, resistive load
<b>Recommended load:</b>	24 V 10mA DC
<b>Min switching load:</b>	6V 10mA DC, resistive load
<b>Contact resistance:</b>	100 mohm
<b>Life, mechanical:</b>	> 1x10 <sup>6</sup> operations at max. 1 Hz

<b>Life, electrical:</b>	Dependant upon electrical load characteristics
<b>Connection cable:</b>	
JSTD1-A:	2m PVC-cable, 4 x 0.75mm <sup>2</sup>
JSTD1-B, JSTD1-E:	4 x 0.75mm <sup>2</sup> wires, approx. 0.2 m
JSTD1-C:	10 m PVC-cable, 4x0.75 mm <sup>2</sup>
<b>Conformity:</b>	EN ISO 12100-1:2003, EN ISO 12100-2:2003, EN 574+A1:2008

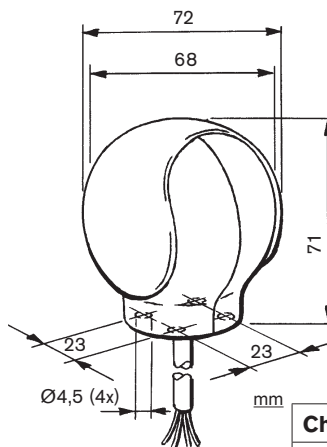

Chemical resistance at 20°C	
Chemical	Resistance
Alcohols	good
Paraffin oil	good
Milk	good
Silicon oil	good
Acetone	good

Please contact us for more information.

## Function - Safeball

### Two hand control device

The Two hand control device is implemented by using two Safeballs™, each having two internal pushbuttons. The Safe-balls™ must be mounted a minimum distance between each other (see Mounting description).

By utilising two pushbuttons in each device a double safety function is provided in each hand.

The highest safety level is achieved by connecting all four pushbuttons to the ABB Jokab Safety JSBR4 safety relay or Pluto Safety-PLC. The safety relay gives a dual and supervised safety function and requires input activation within 0.5 seconds in order to start the machine. It also checks that all four pushbuttons have returned to their deactivated positions before a new start is allowed. The JSBR4 safety relay also provides a stop signal if one or more pushbuttons are released.

### One hand control device

Safeball™ is also a very practical method of providing a one hand control device as it is very easy to find and activate by the machine operator. One hand devices should only be used when the operator cannot reach into the hazardous area with his/her free hand or on less dangerous machines. Before fitting the necessary risk assessment must be made to determine suitability of this type of control. To achieve the highest safety level for One hand control the Safeball™ must be connected to a ABB Jokab Safety safety relay (See Electrical Connection).

### Versions

Safeball is available in several versions to meet different mounting requirements.

- **JSTD1-A** - The standard version with actuators made of plastic and 2 m of cable.
- **JSTD1-B** - Similar to the standard version but without a cable. Instead it has four wires, each 0.2 m long.
- **JSTD1-C** - Similar to JSTD1-A but with 10 m cable.
- **JSTD1-E** - Similar to JSTD1-B but with 2 NO contacts.

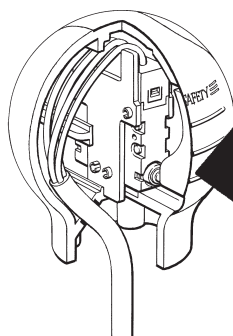

Safeball™, JSTD1, is certified by DNV Inspecta.  
Approval number:  
01-MAL-CM-0101 (Two-hand device)  
01-MAL-CM-0100 (One-hand device)

## Mounting - Safeball

The Safeballs™ can be mounted in many different ways. They can be mounted on a table, a machine, on a support or wherever suitable for ergonomic reasons. The Safeball™ can be mounted in a fixed position or on a tilting and/or rotating support. This flexibility of mounting permits the Safeball™ to be fitted in the best ergonomic position for the ease of operation by the operator. The distance requirement between two Safeballs™ or between a Safeball™ and a wall or edge of a table depends on how the Safeball™ is mounted. Safeball™ can be mounted with four M5 screws or ST4.8 self-tapping screws.

**Note:** When Safeballs™ are mounted in such a way that the distance between them can be adjusted to less than the specified minimum, the mounting screws must be locked to ensure any changes in the distance between the two balls cannot be made.

### Alternative mounting methods

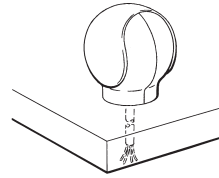

Mounting on a table.



Mounting with ball joint, which can be rotated and angled.

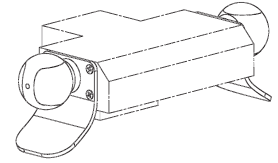

Example of alternative mounting.

### Approved Two hand device

To be an approved Two hand device, both Safeballs™ must be mounted a minimum distance apart in order to prevent operation of both balls with one hand. Safeballs™ must be fitted a minimum distance from the edges of tables or a wall. It is essential that Safeballs™ are correctly installed in order to prevent unintended activation of the devices with part of the body in combination for example with a wall.

## Mounting distance - Safety distance - Safeball

### Mounting distance

Table mounting of two Safeballs™. In order to prevent cheating the distances shown are the minimum allowed.

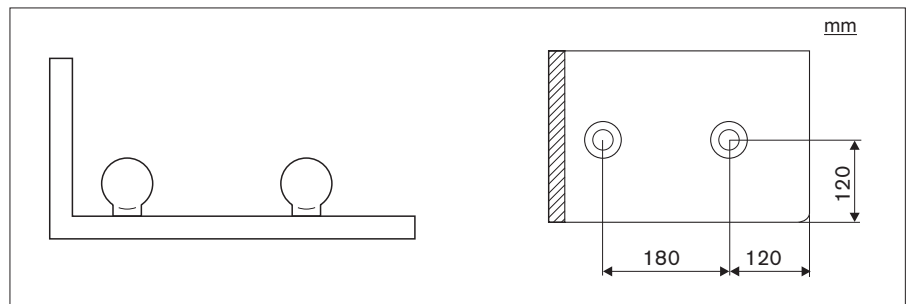

### Safety distance

The Safety distance is the distance between the Safeballs™ and the dangerous machine movement. The safety distance requirement can be calculated using the following formula for Safeball™ in accordance with the approving authority and EN ISO 13855:  
 $S = K \times T + C$

### Where

- S= safety distance in mm
- K= hand speed, 1600 mm/s
- T= total stopping time for the dangerous movement (including the response time of the safety relays in seconds)
- C= Constant= 0 mm for Safeball.

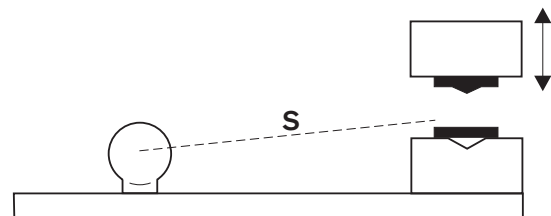

The safety distance is the distance between the Safeballs™ and the dangerous machine movement.

**Note:** S must never be less than 100 mm.

# Electrical connection - Safeball

## Two hand device

Safeballs™ are designed to be connected to a ABB Jokab Safety JSBR4 Safety relay or Safety PLC to achieve the highest safety requirements for a Two hand device.

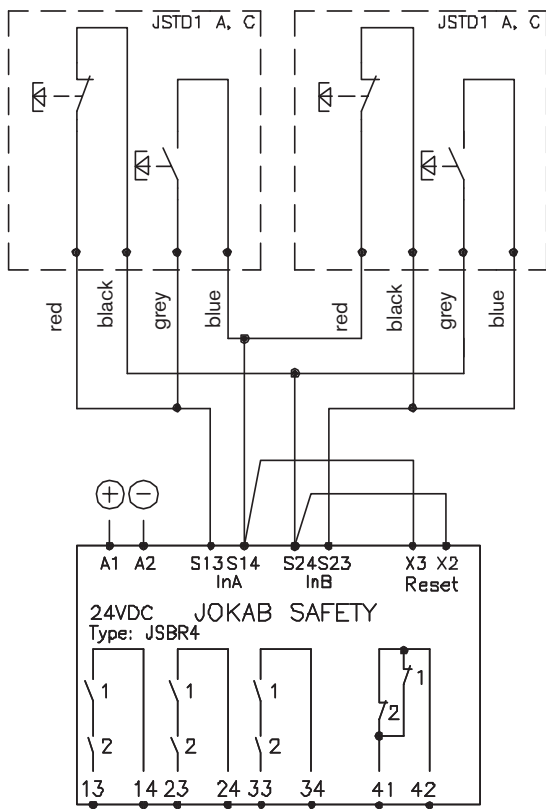

Example of two devices connected to a ABB Jokab Safety JSBR4 safety relay. Response time on receiving a stop signal from JSTD1 < 15 ms.

## One hand device

When used as a One hand device the Safeball™ is designed to be connected to a ABB Jokab Safety RT6, RT7 or RT9 Safety relay in order to achieve the highest possible safety level for this type of control.

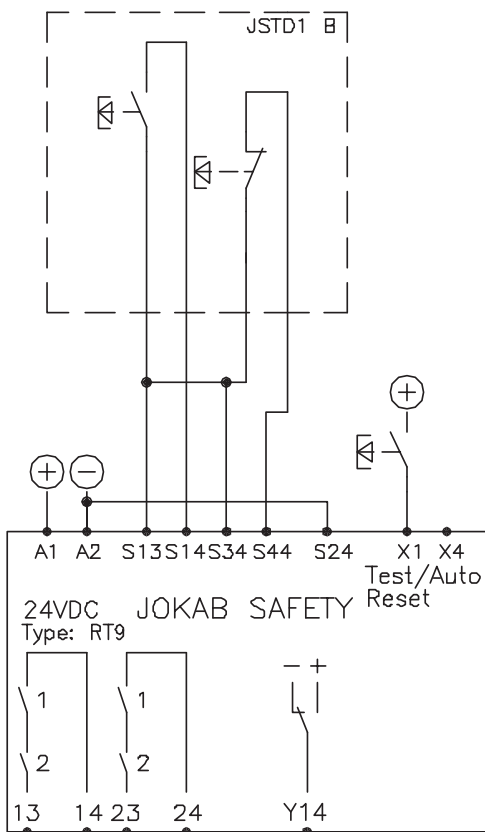

Example of a single Safeball™ connected to a ABB Jokab Safety relay RT9. The response time at 'stop' is < 20 ms.



# Two hand control station JSTD25 with Safeball

With a JSTD25 two hand control station you have a prepared two hand unit that is easy to install, while utilising the good ergonomics of the Safeball. There are several variants to meet differing needs. All versions meet EN 574, EN 954-1 and EN 13849-1 and are supplied with the internal connections made, to simplify installation.

## JSTD25 for fixed installation

JSTD25 A-E: Two Safeballs mounted on a steel housing. Replaces a traditional two hand device. Is available with an emergency stop button and ball joint fixtures for the Safeballs. Three 22 mm openings are prepared on the top for buttons or signal lamps. Hatch for wiring routeing in the

base, securing holes for mounting on the rear. The Safeballs are connected to terminal blocks, for the user to connect the external wiring through one of the two inlet alternatives (underneath or at the rear).



**JSTD25A** Article no. 2TLJ020007R5000 Two hand control station with 2 Safeballs.



**JSTD25D** Article no. 2TLJ020007R5300 Two hand control station with 2 Safeballs, JSMC5.



**JSTD25B** Article no. 2TLJ020007R5100 Two hand control station with 2 Safeballs and emergency stop button.



**JSTD25E** Article no. 2TLJ020007R5400 Two hand control station with 2 Safeballs, JSM C5 and emergency stop button.

## For mobile installation



### JSTD25F/JSTD25H

Article no. 2TLJ020007R6000/2TLJ020007R6300 Two hand control unit with 2 Safeballs. Two Safeballs mounted on the ends of an aluminium profile, shielded by over hand guards. Replaces a traditional two hand device. Installed with the aid of grooves in the aluminium profile. Connection to an M12 connector underneath, JSTD25F with 5 pole M12 connection and JSHD25H with 8 pole M12 Connection. Can be equipped with an external emergency stop (SMILE) and an EDEN sensor for position control. Its low weight makes this particularly suitable for frequent repositioning.



**JSTD25G** Article no. 2TLJ020007R6200 Similar to JSTD25F but the dimensions additional equipment and type of connection can, to a large extent, be customised before delivery. Can also be equipped with doubled protection plates for use in particularly severe conditions.

## For mobile installation with a built-in Eden sensor

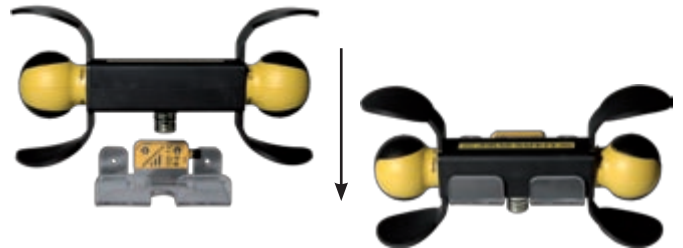

**JSTD25P-1** Article no. 2TLJ020007R6500 Two hand control unit, portable. Two Safeballs mounted on the ends of an aluminium profile, shielded by over hand guards. With built-in Eva sensor for position control. Developed as a portable two hand device, where the response of the machine

to operation can vary at different operating stations, since each station can be connected separately. Connection via an 8+1 Zylin connector. Accessories are a connector, spiral cable with connector and suspension shelf. (article no. 2TLJ020007R8000).

## Accessories - JSTD25

### JSTS31

Article no. 2TLJ020007R4100 Stand with spacer ring for JSTD25 A-E (JSTS30 without spacer ring).



Height  
850-1100 mm

### JSM C5

Article no. 2TLJ020007R0900 Angled ball joint for installation of a Safeball on a table or a steel housing.



### JSTK40S

Article no. 2TLJ020007R6700 4 m long spiral cable for JSTD25P-1

### JSTK80S

Article no. 2TLJ020007R6800 8 m long spiral cable for JSTD25P-1



## Connection example - JSTD25/A/B/D/E

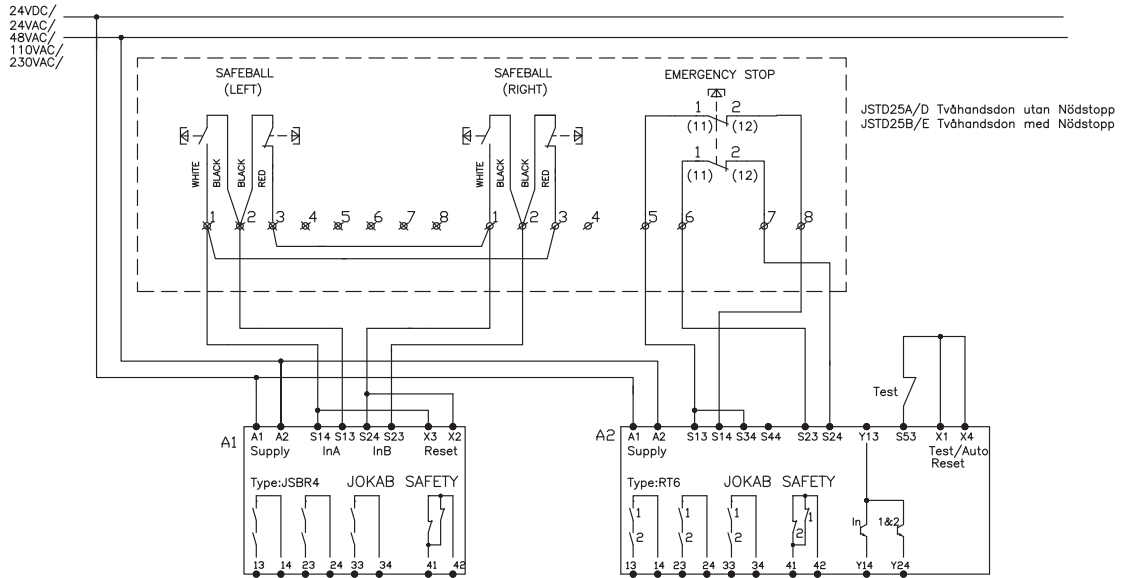

## Connection example - JSTD25F

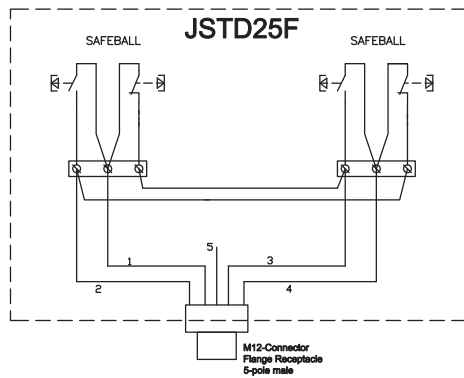

M12 5 Color-code  
(not always used, verify!)  
1 Brun Brown Braun Marron  
2 Vit White Weiss Blanc  
3 Blå Blue Blau Bleu  
4 Svart Black Schwartz Noir  
5 Not connected

1 Dyn A out  
2 Pluto to evaluate A = OK, and test B (two inputs)  
3 Pluto to evaluate B = OK, and test A (two inputs)  
4 Dyn B out

According to standard Pluto Twohand1 block:  
I1: Right\_NO  
I2: Left\_NC  
I3: Right\_NC  
I4: Left\_NO

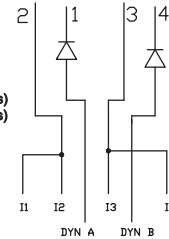
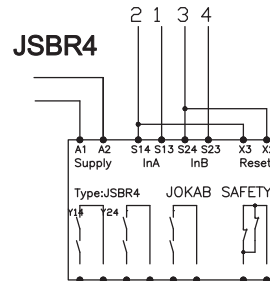

## Connection example - JSTD25H

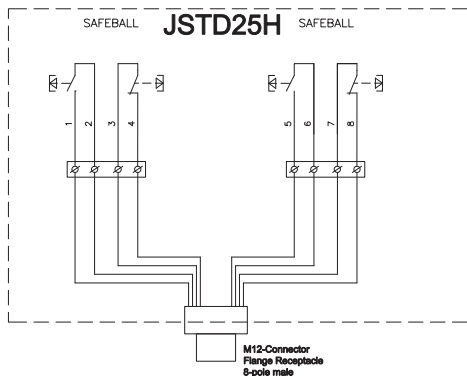

M12-C03  
Contact (plug) for self assembly. Female.  
As seen from cable side (inside).  
Ordered separately.

M12 8 Color-code  
(not always used, verify!)  
1 Vit White Weiss Blanc  
2 Brun Brown Braun Marron  
3 Grön Green Grün Vert  
4 Gul Yellow Gelb Jaune  
5 Grå Grey Grau Gris  
6 Rosa Pink Rosa Rose  
7 Blå Blue Blau Bleu  
8 Röd Red Rot Rouge

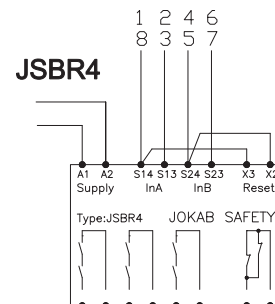
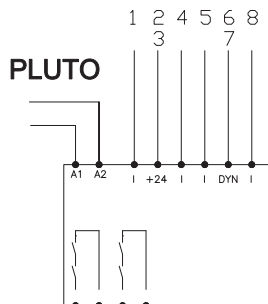

# Connection example - JSTD25P-1

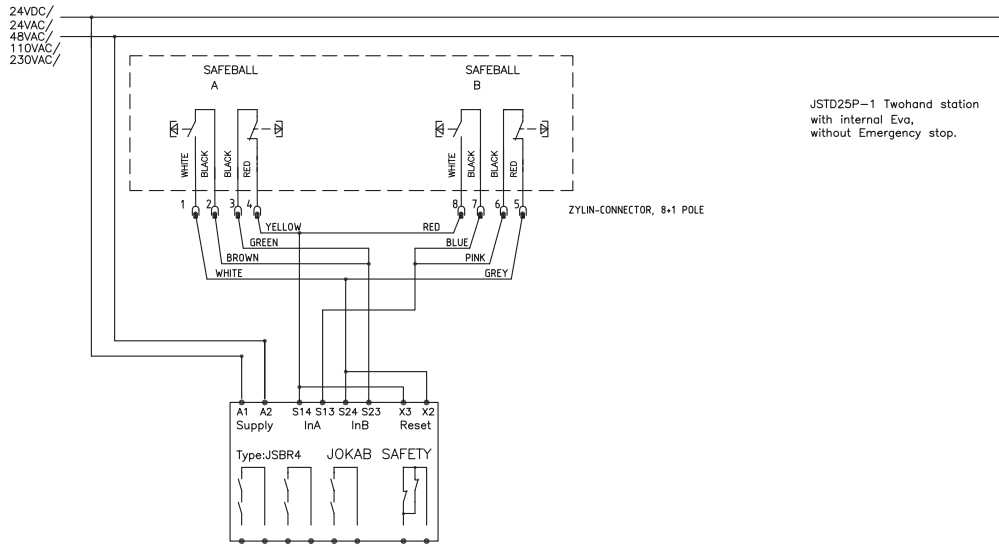

# Dimension sketch - JSTD25

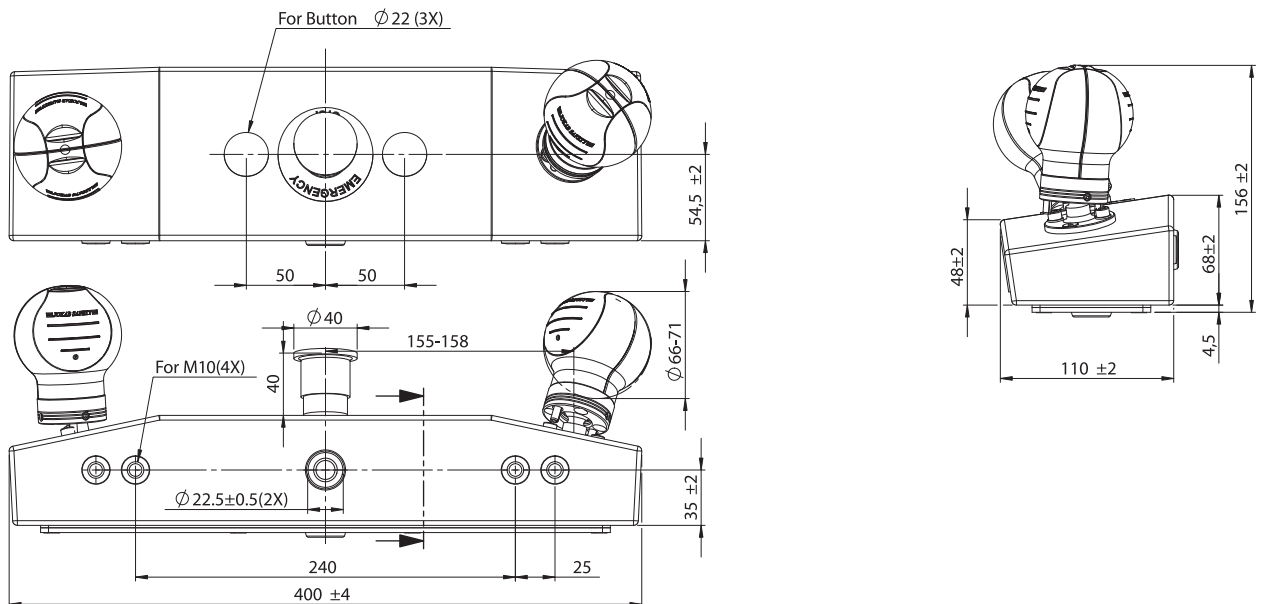
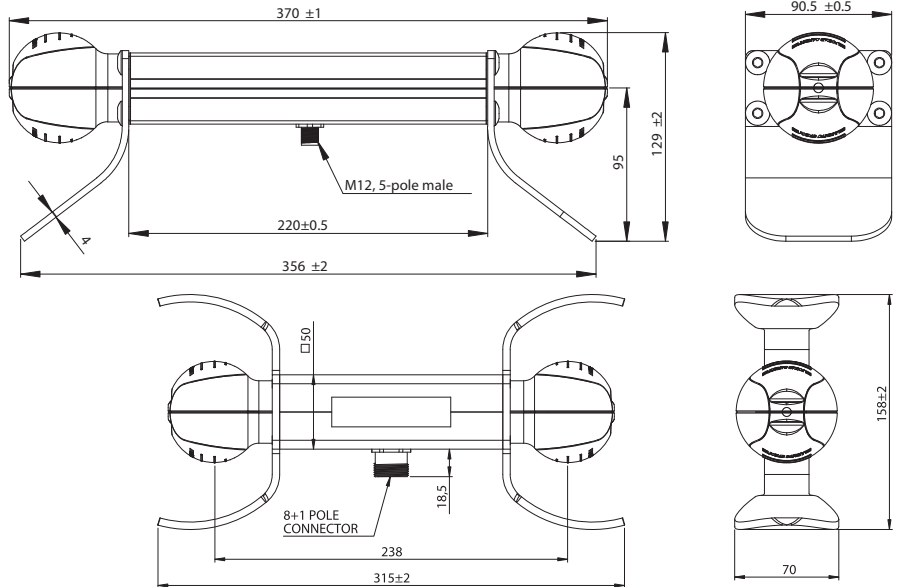
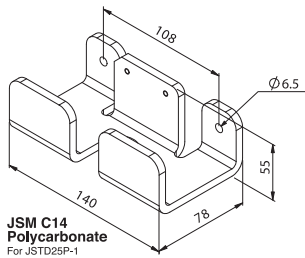
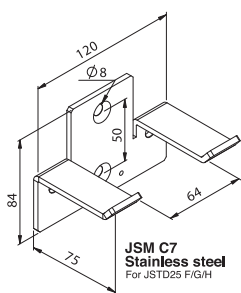

# Two hand device

# JSTD20



## Conventional Two hand device

The conventional JSTD20 Two hand device utilises a welded steel housing. Two operating pushbuttons are protected by over hand guards. Between these pushbuttons there is space for an emergency pushbutton and two extra controls or indication lamps. Below each of the operating pushbuttons is one normally open and one normally closed contact. To start and run the machine both pushbuttons must be activated within 0.5 seconds. If one or both pushbuttons are released a stop signal is given to the machine, and all contacts must return to their deactivated positions before a new start is allowed.

The design is robust and can withstand harsh environments and long use. The pushbuttons and contact blocks are simple to assemble for quick and easy installation. The device can be mounted directly on the machine, on the ABB Jokab Safety fencing system or on the JSTS30 floor mount. For use with portable Two hand devices the JSTS31 floor mount, which is provided with a spacer ring to fulfil the requirements of EN 574, is recommended. The JSTD20 is available with or without an emergency stop pushbutton.

### Highest level of safety

Correct connection to a ABB Jokab Safety JSBR4 safety relay or Pluto Safety PLC ensures the highest level of safety with dual and supervised safety function and requires input

## Approvals



## JSTD20 for:

- Presses
- Punching machines
- Cutting machines
- Fixtures

## Features:

- Durable material
- With or without emergency stop pushbutton
- Fulfils requirements of EN 574
- Highest level of safety

activation of both operating pushbuttons within 0.5 seconds (two hand device type III C in accordance with EN 574). If the emergency pushbutton is installed it should be provided with two normally closed contacts and be connected to a separate safety relay, e.g. from the RT series or Pluto.

### Why use a Two hand device?

A two hand device can be used when it is necessary to ensure that the operator is outside and must be prevented from reaching into the hazardous area. If the operator decides, after the start signal has been given to the machine, to make an 'after grasp' i.e. try to adjust the part that has been placed inside the machine, then a dual stop signal is given to the machine.

The new JSTD20 is equipped with a new type of large over hand guards in accordance with EN 574. These prevent unintended activation by for instance a knee or elbow.

A Two hand device only protects the operator using it. Large machines operated by several operators can be equipped with one control for each operator.

To calculate the correct safety distance, which depends on the machine's stopping time including the response time of the relay, the use of the ABB Jokab Safety Smart Stopping analyser is recommended.

Technical data - JSTD20	
<b>Manufacturer</b>	ABB AB/Jokab Safety, Sweden
<b>Article number/ ordering number</b>	2TLJ020007R2000 JSTD20A 2TLJ020007R2100 JSTD20B 2TLJ020007R2200 JSTD20C
<b>Weight</b>	JSTD20: 6.4 Kg JSTS30: 20 Kg JSTS31: 23 Kg
<b>Colour</b>	Black housing, Black pushbut- tons, Black floor stand.
<b>Temperature</b>	-10°C...+70°C (Operating) -20°C to +70°C (storage)
<b>Safety level</b> EN ISO 13849-1 EN 954-1	Upp till kat. 4/PL e Upp till kat. 4
<b>Material</b>	Housing: 3mm Steel Gasket: Rubber Pushbuttons: Plastic
<b>Operating pushbuttons</b>	
Diameter	60 mm
Operating force	Approx. 9N
Operating distance	3.5±1 mm
Mechanical life	10 <sup>6</sup> operations
<b>Emergency pushbutton</b> (JSTD20B only)	
Diameter	40 mm
Operating force	40N
Mechanical life	3 x 10 <sup>5</sup> operations
Contacts	Mechanically separated contact blocks
<b>Operating pushbuttons</b>	1 NO + 1 NC
<b>Emergency pushbuttons</b>	2 x NC
<b>Isolation voltage</b>	690V rms
<b>Contact resistance</b>	20 mohm

<b>Rated current</b>	10A
<b>Utilisation categories</b>	AC 15 240V 3A DC 13 240V 0.27A
<b>Cabling</b>	screw clamp terminals, 1 or 2 wires with max. cross-section 2.5 mm <sup>2</sup> .
<b>Contact material</b>	silver alloy on brass
<b>Protection class:</b>	IP 65
<b>Conformity:</b>	EN 418, EN 574, EN 954-1, EN ISO 13849, EN 60947-1, EN 60947-5-1, EN 999

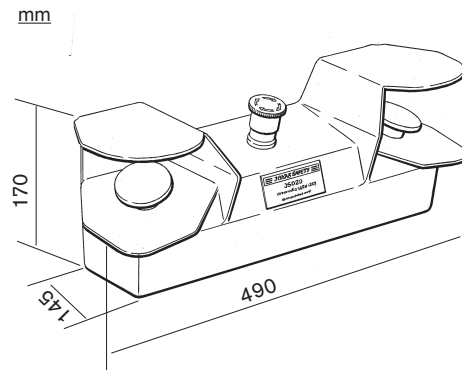

JSTD20A – Two hand device, without emergency stop  
JSTD20B – Two hand device, with emergency stop  
JSTD20C – Only housing, no buttons

## Connection example - JSTD20

The Two hand device is intended for use with ABB Jokab Safety's JSBR4 safety relay (or Pluto Safety PLC) to ensure the highest level of safety. The JSBR4 ensures that all contacts have returned to their deactivated positions before a new start is allowed. The safety relay also requires that all contacts are activated within 0.5 seconds. The JSBR4 gives a stop signal if one or both of the pushbuttons are released.

