

**Industrial  
Equipment  
Manufacturing**

# Secured Edge Analyzer

Intelligent Platform with Azure IoT Edge

Edge  
Solution Ready  
Package

**ESRP-CSS-UN02484**



- Extends cloud intelligence and analytics to edge devices
- Boosts productivity and response times with data insights
- Offers secure cloud communication and edge intelligence



 Microsoft Azure

**WISE-PaaS/EdgeLink**



**Supports Numerous IoT Modules**

Data Filter

Stream Analysis

Database Localization

Machine Learning

**ADVANTECH**

*Enabling an Intelligent Planet*

POWERED BY  
**ADVANTECH**  
**WISE-PaaS**

# Edge Solution-Ready Package

## ESRP-CSS-UNO2484



### Extends cloud intelligence and analytics to edge devices

IoT solutions, such as stream analytics, machine learning, image recognition, and other high-value AI modules, deployed from the cloud to the edge to support diverse applications.



### Boosts productivity and response times with data insights

Local data processing enables immediate decision-making and reduces bandwidth costs by minimizing the data transmitted from local devices to the cloud.



### Offers secure cloud communication and edge intelligence

The inclusion of Azure IoT Edge Security Daemon and onboard TPM 2.0 increases device security while a SSL ensures connectivity between the cloud and intelligent edge.

Intelligent Platform with Azure IoT Edge	
Part Number	ESRP-CSS-UNO2484
Operating System	AdvLinuxTU
Software	Microsoft Azure IoT Edge Engine, Advantech WISE-PASS/Edgelink
Form Factor	Regular with stackable design and front-facing I/O
CPU	Intel® Core™ i5-7300U (2.6 GHz)
Memory	8 GB DDR4
Display Type	1 x HDMI supports 1920 x 1080 @ 60 Hz, 1 x DP supports 3840 x 2160 @ 30 Hz
Storage	32 GB SSD
LED Indicators	Power, HDD, LAN (Active, Status), RTC Battery
Expansion Slots	1 x Full-size mPCIe
Mount Options	Stand, wall with optional VESA and DIN rail
Network(LAN)	4 x RJ45, 10/100/1000 Mbps IEEE 802.3u 1000 BASE-T fast Ethernet
I/O	4 x RS-232/422/485, DB9, 4 x USB 3.0
Dual DC Power Input	10 ~ 36 V <sub>DC</sub>
Operating Temperature	-20 ~ 60 °C (-4 ~ 140 °F)
Storage Temperature	-40 ~ 85 °C (-40 ~ 185 °F)
Dimensions (W x D x H)	200 x 140 x 40 mm (7.8 x 5.6 x 1.6 in)
Certification	CE, FCC, CCC, BSMI, UL

### Ordering Information

ESRP-CSS-UNO2484

Intelligent platform with Azure IoT Edge, UNO-2484G-7531AE, 8 GB RAM, 32 GB SSD, AdvLinuxTU

**ADVANTECH**

*Enabling an Intelligent Planet*

# WISE-4051

## 8-ch Digital Input IoT Wireless I/O Module with RS-485 Port



CE FC R&TTE SRRC

### Introduction

The WISE-4051 is an Ethernet-based wireless IoT device, integrated with IoT data acquisition, processing, and publishing functions. As well as various I/O types, the WISE-4051 provides data pre-scaling, data logic, and data logger functions. Data can be accessed via mobile devices and be securely published to the cloud anytime from anywhere.

### Features

#### IEEE 802.11 b/g/n 2.4GHz Wi-Fi with AP Mode

The Wi-Fi interface is easily integrated with wired or wireless Ethernet devices, users only need to add a wireless router or AP to extend existing Ethernet network to wireless. The limited AP mode enables the WISE-4000 to be accessed via other Wi-Fi devices directly as an AP.



#### Modbus/RTU to Web Service or Modbus/TCP

The RS-485 port of the WISE-4051 supports Modbus, which can be used to poll the data from Modbus/RTU devices, like ADAM-4000, or ADAM-5000/485. Then you can access the data by Modbus or REST from the WISE-4051. The data can also be logged.



### Features

- 8-ch digital input with 1-port RS-485 for Modbus devices
- 2.4GHz Wi-Fi reducing the wiring cost during big data acquisition
- Easily extend the existing network by adding APs, and share existing Ethernet software
- Configured by mobile devices directly without installing any software or Apps
- Zero data loss using the log function with RTC time stamp
- Data can be automatically pushed to Dropbox or computer
- Supports RESTful web API in JSON format for IoT integration

#### RESTful Web Service with Security Socket

As well as supporting Modbus/TCP, the WISE-4051 series also supports IoT communication protocol, RESTful web service. Data can be polled or even be pushed automatically from the WISE-4051 when the I/O status is changed. The I/O status can be retrieved over the web using JSON. The WISE-4051 also supports HTTPS which has security that can be used in a Wide Area Network (WAN).



#### Data Storage

The WISE-4000 can log up to 10,000 samples of data with a time stamp. The I/O data can be logged periodically, and also when the I/O status changes. Once the memory is full, users can choose to overwrite the old data to ring log or just stop the log function.



#### Cloud Storage

Data logger can push the data to file-based cloud services like Dropbox using pre-configured criteria. With RESTful API, the data can also be pushed to a private cloud server in the format of JSON. Users can setup their private cloud server using the provided RESTful API and their own platform.



- 1 Software and Industry Solutions
- 2 Industrial Server
- 3 Intelligent System
- 4 Intelligent HMI and Monitors
- 5 Automation Computers and Controllers
- 6 Industrial Communication
- 7 Remote I/O & Wireless Sensing Modules
- 8 Industrial I/O and Video Solutions

## Specifications

### Digital Input

- **Channels** 8
- **Logic Level** Dry Contact 0: Open  
1: Close to DCOM
- Wet Contact 0: 0 ~ 3 V<sub>DC</sub>  
1: 10 ~ 30 V<sub>DC</sub> (3 mA min.)
- **Isolation** 3,000 V<sub>rms</sub>
- **Supports 3 kHz Counter Input (32-bit + 1-bit overflow)**
- **Keep/Discard Counter Value when Power-off**
- **Supports 3 kHz Frequency Input**
- **Supports Inverted DI Status**

### Serial Port

- **Port Number** 1
- **Type** RS-485
- **Serial Signal** DATA+, DATA-
- **Data Bits** 7, 8
- **Stop Bits** 1, 2
- **Parity** None, Odd, Even
- **Baud Rate** 1200, 2400, 4800, 9600, 19200, 38400, 57600, 115200 (bps)
- **Protection** 15 kV ESD
- **Protocol** Modbus/RTU (Total 32 address by max. 8 instructions)

### General

- **WLAN** IEEE 802.11b/g/n 2.4GHz
- **Outdoor Range** 110 m with line of sight
- **Connectors** Plug-in screw terminal block (I/O and power)
- **Watchdog Timer** System (1.6 second) and Communication (programmable)
- **Certification** CE, FCC, R&TTE, NCC, SRRC, RoHS
- **Dimensions (W x H x D)** 80 x 148 x 25 mm
- **Enclosure** PC
- **Mounting** DIN 35 rail, wall, and stack
- **Power Input** 10 ~ 30 V<sub>DC</sub>
- **Power Consumption** 2.2 W @ 24 V<sub>DC</sub>
- **Power Reversal Protection**
- **Supports User Defined Modbus Address**
- **Supports Data Log Function** Up to 10000 samples with RTC time stamp
- **Supported Protocols** Modbus/TCP, TCP/IP, UDP, DHCP, and HTTP
- **Supports RESTful Web API in JSON format**
- **Supports Web Server in HTML5 with JavaScript & CSS3**
- **Supports System Configuration Backup and User Access Control**

### Environment

- **Operating Temperature** -25 ~ 70°C (-13~158°F)
- **Storage Temperature** -40 ~ 85°C (-40~185°F)
- **Operating Humidity** 20 ~ 95% RH (non-condensing)
- **Storage Humidity** 0 ~ 95% RH (non-condensing)

## Pin Assignment

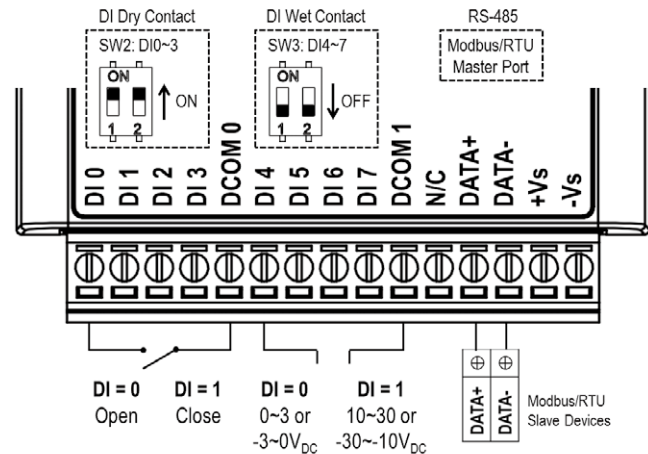

## Ordering Information

- **WISE-4051-AE** 8-ch Digital Input IoT Wireless I/O Module with RS-485 Port

### Selection Table

Model Name	Universal Input	Digital Input	Digital Output	Relay Output	RS-485
WISE-4012	4		2		
WISE-4050		4	4		
WISE-4051		8			1
WISE-4060		4		4	

### Accessories

- **PWR-242-AE** DIN-rail Power Supply (2.1A Output Current)
- **PWR-243-AE** Panel Mount Power Supply (3A Output Current)
- **PWR-244-AE** Panel Mount Power Supply (4.2A Output Current)

## Dimensions

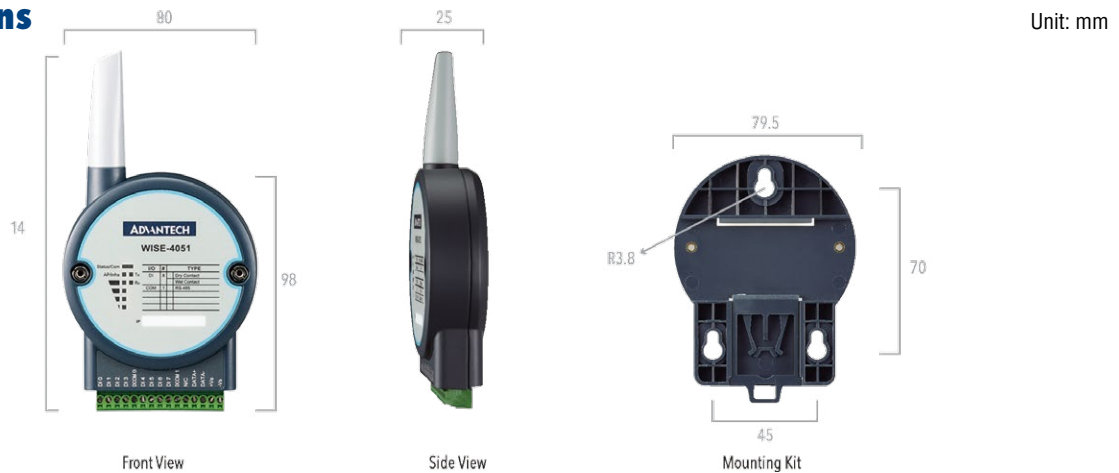

# IoT Wireless I/O Modules



Model		WISE-4012E	WISE-4012	WISE-4050	WISE-4060	WISE-4051
Description		6-ch IoT wireless I/O module for IoT developers	4-ch universal input + 2-ch digital output IoT wireless I/O module	4-ch digital input + 4-ch digital output IoT wireless I/O module	4-ch digital input + 4-ch relay output IoT wireless I/O module	8-ch digital input IoT wireless I/O module with 1 x RS-485 port
Wireless Interface	IEEE Standard	IEEE 802.11b/g/n	IEEE 802.11b/g/n	IEEE 802.11b/g/n	IEEE 802.11b/g/n	IEEE 802.11b/g/n
	Frequency Band	2.4 GHz	2.4 GHz	2.4 GHz	2.4 GHz	2.4 GHz
	Outdoor Range	110 m (L.O.S.)	110 m (L.O.S.)	110 m (L.O.S.)	110 m (L.O.S.)	110 m (L.O.S.)
	Network Mode	Infrastructure, Limited AP	Infrastructure, Limited AP	Infrastructure, Limited AP	Infrastructure, Limited AP	Infrastructure, Limited AP
	Security	WPA2 Personal and Enterprise	WPA2 Personal and Enterprise	WPA2 Personal and Enterprise	WPA2 Personal and Enterprise	WPA2 Personal and Enterprise
	Antenna Connector	Reverse SMA	Reverse SMA	Reverse SMA	Reverse SMA	Reverse SMA
Analog Input	Channel	2-ch (differential)	4-ch		-	
	Input Type	V	V, A, Dry contact DI		-	
	Voltage Range	0 ~ 10 V	±150 mV, ±500 mV, ±1 V, ±5 V, ±10 V, 0 ~ 150 mV, 0 ~ 500 mV, 0 ~ 1 V, 0 ~ 5 V, 0 ~ 10 V		-	
	Current Range	-	0 ~ 20, 4 ~ 20, ±20 mA		-	
	Resolution	12-bit	16-bit		-	
	Sampling Rate	10 Hz (total)	10 Hz (total)		-	
	Accuracy	±0.1 V <sub>DC</sub>	Voltage: ±0.1% of FSR Current: ±0.2% of FSR		-	
	Burnout Detection	-	✓ (4 ~ 20 mA only)		-	
	Isolation	-	3,000 V <sub>rms</sub>		-	
	Digital Input	Channel	2-ch dry contact	Shared with analog input	4-ch dry contact or wet contact	4-ch dry contact or wet contact
Counter Input		3 kHz	2 Hz	3 kHz	3 kHz	3 kHz
Frequency Input		0.1 ~ 3 kHz	0.1 ~ 2 Hz	0.1 ~ 3 kHz	0.1 ~ 3 kHz	0.1 ~ 3 kHz
Isolation		-	3,000 V <sub>rms</sub>	3,000 V <sub>rms</sub>	3,000 V <sub>rms</sub>	3,000 V <sub>rms</sub>
Digital Output	Channel	2-ch relay	2-ch (sink-type)	4-ch (sink-type)	4-ch power relay	-
	Output Rating (Resistive Load)	120 V <sub>AC</sub> @ 0.5 A 30 V <sub>DC</sub> @ 1 A	Open collector to 30 V <sub>DC</sub> , 400 mA max.		250 V <sub>AC</sub> @ 5 A 30 V <sub>DC</sub> @ 3 A	-
	Pulse Output	60 operations/min	5 kHz	5 kHz	60 operations/min	-
	Isolation	1,500 V <sub>rms</sub>	3,000 V <sub>rms</sub>	3,000 V <sub>rms</sub>	3,000 V <sub>AC</sub>	-
Serial Port	Port Number					1
	Type					RS-485
	Data Bits					7, 8
	Stop Bits					1, 2
	Parity					None, odd, even
General	LED Indicators	Status, communication, network mode, quality	Status, communication, network mode, quality	Status, communication, network mode, quality	Status, communication, network mode, quality	Status, communication, network mode, quality, serial Tx, Rx
	Real-Time Clock	✓	✓ (with battery backup)	✓ (with battery backup)	✓ (with battery backup)	✓ (with battery backup)
	Connectors	I/O: Terminal block Power: Micro-B USB	Plug-in screw terminal block (I/O and power)	Plug-in screw terminal block (I/O and power)	Plug-in screw terminal block (I/O and power)	Plug-in screw terminal block (I/O and power)
	Dimensions	80 x 148 x 25 mm (W x H x D)				
Environment	Operating Temperature	-25 ~ 70°C (-13 ~ 158°F)				
	Storage Temperature	-40 ~ 85°C (-40 ~ 185°F)				
	Operating Humidity	20 ~ 95% RH (non-condensing)				
	Storage Humidity	0 ~ 95% RH (non-condensing)				
Power	Input Range	Micro USB 5 V <sub>DC</sub>	10 ~ 30 V <sub>DC</sub>	10 ~ 30 V <sub>DC</sub>	10 ~ 30 V <sub>DC</sub>	10 ~ 30 V <sub>DC</sub>
	Protection	-	Power reversal protection	Power reversal protection	Power reversal protection	Power reversal protection
	Power Consumption	1.5 W @ 5 V <sub>DC</sub>	2.5 W @ 24 V <sub>DC</sub>	2.2 W @ 24 V <sub>DC</sub>	2.5 W @ 24 V <sub>DC</sub>	2.2 W @ 24 V <sub>DC</sub>

# WISE-4210-AP

# WISE-4210-S231

# WISE-4210-S251

## LPWAN IoT Wireless to Ethernet AP

## LPWAN IoT Wireless Sensor Node

## LPWAN IoT Wireless Sensor Node

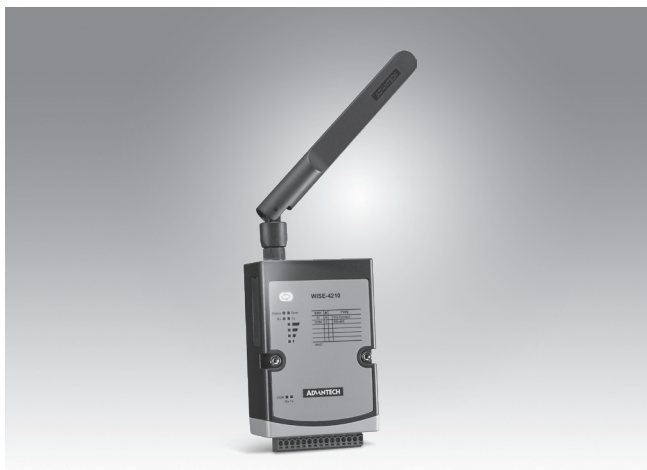

### Introduction

LPWAN, created for machine-to-machine (M2M) and Internet of things (IoT) networks, is not a single technology, but a variety of low-power, wide area network technologies. Compared with traditional mobile network, LPWAN is known as lower cost with higher power efficiency. WISE-4210 series is the proprietary LPWAN which provides better connection compare with traditional 2.4G WiFi, WISE-4210 series is helpful of eliminating network interference.

Additionally, WISE-4210 utilize a LPWAN(low-power, wide-area networks) wireless interface, which has a kilometer-long communication distance and battery power. The features of LPWAN make WISE modules ideal solutions for energy and environment monitoring.

### Reduced Interference and Extended Communication Range

Compared with Wi-Fi, Bluetooth, Zigbee, or other 2.4GHz wireless interfae, a sub-GHz interface can reduce interference at sites. Moreover, Sub-GHz is a type of LPWAN designed for long-range communications. Under the same power consumption, sub-GHz offers a longer communication range with low data rate than other 2.4 GHz. technologies.

### Powered by a 3.6V AA Lithium Battery

The low power consumption of sub-GHz enables the sensor node to be powered by a battery. With a 3.6V AA Lithium battery, the sensor node can maintain communication at a distance of 5 km for up to 5 years, thereby eliminating the need to recharge or change batteries.



### Star Topology

Star topology, also known as star network, is the most common network setup. In star topology, every node connects to a central network device which means WISE-4210-S200 series nodes acts as clients should be connected with WISE-4210-AP. In this configuration, user can organize their own network with 64 nodes paired. Data on a star network pass through WISE-4210-AP before continuing to its destination. WISE-4210-AP with a LAN cable manages and controls most of all functions of the network.

### Features

- Proprietary LPWAN with using sub-1GHz wireless frequency
- Battery power for 5 years with 3 x 3.6V AA batteries
- Up to 5 km communication range in open space
- Longer communication range than 2.4GHz
- Better penetration through concrete and steel than 2.4GHz
- Less interference than 2.4GHz spectrum
- Application-ready I/O combination with modularization design

### MQTT and RESTful API IoT Protocol Support

IoT Wireless sensor nodes are designed for not only automation applications but also IoT applications that may use MQTT or RESTful web API IoT protocols for cloud integrations.

### Azure IoT Hub Support

To provide a complete IoT sensing solution, the WISE-4210 series goes beyond being a wireless communication interface for sensors—it also provides cloud connectivity for additional user applications. With support for HTTPS and integrated APIs for Azure IoT Hub, the WISE-4210 series can automatically push data to the cloud without requiring an IoT gateway.

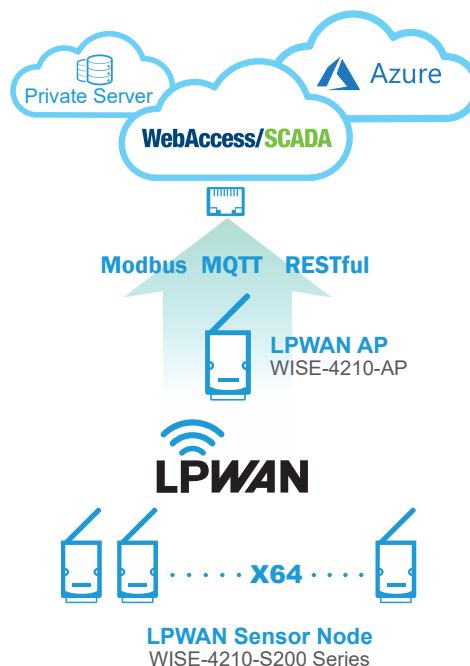

## Common Specification

### Wireless Communication

- **IEEE Standard** 625bps: IEEE 802.15.4g FSK Modulation  
50kpbs: IEEE 802.15.4g GFSK Modulation
- **Frequency Band** AS923: 923MHz (920.60~924.60), BW: 400kHz  
EU868: 868MHz (865.00~869.00), BW: 400kHz  
UN433: 433MHz (433.05~434.55), BW: 300kHz
- **Antenna Gain** 902~928MHz:1.33 dBi  
863~870MHz:2.19 dBi
- **Data Rate** 625bps, 50kpbs
- **Outdoor Range** 625bps: 5 km with line of sight  
50kpbs: 2 km with line of sight
- **Topology** Star
- **Network Capacity** 64 clients

### General

- **Power Input** AP: 10 ~ 50 V<sub>DC</sub>  
Sensor Node: 3 x AA, 3.6V Lithium Battery or 10 ~ 50 V<sub>DC</sub>
- **Battery Life** 625bps: 5 years with 10 minute update rate  
50kpbs: 5 years with 1 minute update rate
- **Configuration Interface** AP: LAN port  
Sensor Node: Micro-B USB
- **LED Indicator** Status, Error, Tx, Rx, Battery/Signal Level
- **Mounting** DIN 35 rail, wall, pole and stack
- **Dimension (W x H x D)** 70 x 102 x 38 mm
- **Certification** CE (RED), FCC, IC, NCC, TELEC

### Environment

- **Operating Temperature** -25 ~ 70°C
- **Operating Humidity** 5 ~ 95% RH
- **Storage Temperature** -40 ~ 85°C
- **Storage Humidity** 0 ~ 95% RH

## WISE-4210-AP

### General

- **Ethernet** RJ-45 (for configuration and data query)
- **RS-485** Data+, Data- (for query node data)
- **Messaging Protocol** Modbus/TCP, Modbus/RTU, REST, MQTT
- **Application Protocol** HTTP, HTTPS, SNMP, DHCP
- **Transport Protocol** TCP, UDP
- **Supports RESTful Web API in JSON format**
- **Supports Web Server in HTML5**

## WISE-4210-S231

### Temperature Sensor

- **Operating Range** -25°C ~ 70°C (-13°F ~ 157.9°F)
- **Resolution** 0.1 (°C/°F/K)
- **Accuracy** ±1.0°C (±1.8°F) (vertical installation)

### Humidity Sensor

- **Operating Range** 10 ~ 90% RH
- **Resolution** 0.1% RH
- **Accuracy** ±4% RH @ for 0%~50% RH  
±6% RH @ 50%~60% RH  
±10% RH @ 60%~90% RH

## WISE-4210-S251

### Digital Input

- **Channels** 6 (Dry Contact)
- **Supports 32-bit counter input function (maximum signal frequency 200Hz)**
- **Supports keep/discard counter value on power-off**
- **Support inverted digital input status**

### Serial Port

- **Port Number** 1
- **Type** RS-485
- **Data Bits** 7, 8
- **Stop Bits** 1, 2
- **Parity** None, Odd, Even
- **Baud Rate (bps)** 1200, 2400, 4800, 9600, 19200, 38400, 57600, 115200
- **Protocol** Modbus/RTU (Total 32 address by max. 8 instructions)

## Pin Assignment

### WISE-4210-AP

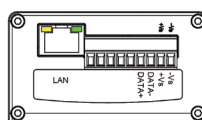

### WISE-4210-S231

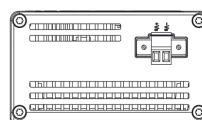

### WISE-4210-S251

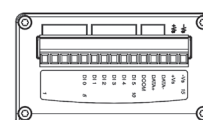

## Ordering Information

### Wireless Access Point

- **WISE-4210-APNA\*** LPWAN Wireless to Ethernet AP – AS923/EU868
- **WISE-4210-APUA** LPWAN Wireless to Ethernet AP – UN433

### Wireless Sensor Node

- **WISE-4210-S231NA\*** LPWAN WSN with Temp/RH Sensors – AS923/EU868
- **WISE-4210-S251NA\*** LPWAN WSN with 6DI and RS-485 – AS923/EU868
- **WISE-4210-S231UA** LPWAN WSN with Temp/RH Sensors – UN433
- **WISE-4210-S251UA** LPWAN WSN with 6DI and RS-485 – UN433

### Accessories

- **1760002647-01** Bat.Cylindrical 3.6V/2500mAh AA Li/SOCI2
- **1750008836-01** 863~870MHz Dipole Antenna for WISE-4210
- **1750008837-01** 902~928MHz Dipole Antenna for WISE-4210

\* AS923/EU868 version of WISE-4210 need to order antenna separately

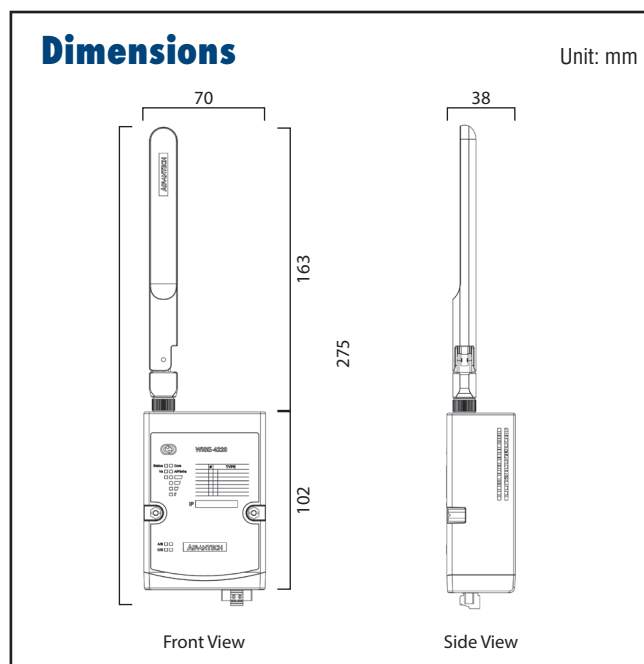

# IoT Wireless Sensor Nodes



Wireless		Wi-Fi			LoRa	
Model Name		WISE-4220-S231	WISE-4220-S214	WISE-4220-S215	WISE-4610-S672	WISE-4610-S614
Description		Wireless IoT WSN with Temperature/Humidity Sensors	Wireless IoT WSN with 4-ch AI and 4-ch DI	Wireless IoT WSN with 4-ch RTD	LoRa WSN with 2 Serial Port & 6-ch DI	LoRa WSN with 4-ch AI and 4-ch DI
Wireless Interface	Function	Wireless Sensor Node	Wireless Sensor Node	Wireless Sensor Node	Wireless Sensor Node	Wireless Sensor Node
	IEEE Standard	IEEE 802.11b/g/n			IEEE 802.15.4g LoRa Modulation	
	Frequency Band	2.4GHz			NA915, EU868, JP925, CN470	
	Mode / Topology	Infrastructure, Limited AP			Star	
	Outdoor Range	110m (L.O.S.)			5000m (L.O.S.)	
Network	GNSS	-			GPS/GLONASS/BeiDou	
	Interface	WLAN			Micro-B USB	
Analog / Sensor Input	Protocol	Modbus/TCP, REST, MQTT, Azure			-	
	Channel	Built-in Sensors	4-ch	4-ch	-	4-ch
	Input Type	Temperature, Humidity	V, A	2, 3-wire Pt RTD	-	V, A
Digital Input / Output	Input Range	-25 ~ 70°C 0 ~ 90% RH	0~10V, 0~20mA, 4~20mA	Pt-100: -200~200°C Pt-1000: -40~160°C	-	0~10V, 0~20mA, 4~20mA
	Channel	-	4-ch Dry Contact DI	-	6-ch Dry Contact DI	4-ch Dry Contact DI
Serial Port	Port Number	-	-	-	1-port RS-485 1-port RS-232/485	-
	Battery Power	-				Solar Rechargeable Battery
Power Input	External Power	10 ~ 50 V <sub>DC</sub>			10 ~ 50 V <sub>DC</sub>	



Wireless		Cellular				
Model Name		WISE-4470-S250	WISE-4470-S414	WISE-4470-S472	WISE-4670-S672	WISE-4670-S614
Description		3G WSN with 1-port RS-485 and DIO	IP65 3G WSN with 4-ch AI	IP65 3G WSN with 2 Serial Port	Outdoor 3G WSN with 2 Serial Port & 6-ch DI	Outdoor 3G WSN with 4-ch AI and 4-ch DI
Wireless Interface	Function	Wireless Sensor Node	Wireless Sensor Node	Wireless Sensor Node	Wireless Sensor Node	Wireless Sensor Node
	IEEE Standard	GSM/GPRS/HSPA			GSM/GPRS/HSPA	
	Frequency Band	UMTS/HSPA: 1/8 (900/2100MHz) GSM/GPRS/EDGE: 2/3/5/8(1900/1800/850/900MHz)			UMTS/HSPA: 1/8(2100/900MHz) GSM/GPRS/EDGE: 2/3/5/8(1900/1800/850/900MHz)	
	Outdoor Range	-			-	
	GNSS	-			GPS/GLONASS/BeiDou	
Network	Configuration	Micro-B USB			Micro-B USB	
	Protocol	REST, MQTT, Azure			REST, MQTT, Azure	
Analog / Sensor Input	Channel	-	4-ch	-	-	4-ch
	Input Type	-	V, A	-	-	V, A
	Input Range	-	0~10V, 0~20mA, 4~20mA	-	-	0~10V, 0~20mA, 4~20mA
Digital Input / Output	Channel	6-ch Dry Contact DI 2-ch Sink-type DO	-	-	6-ch Dry Contact DI	4-ch Dry Contact DI
Serial Port	Port Number	1-port RS-485 for Modbus/RTU	-	1-port RS-485 1-port RS-232/485	1-port RS-485 1-port RS-232/485	-
	Battery Power	-				Solar Rechargeable Battery
Power Input	External Power	10 ~ 50 V <sub>DC</sub>			10 ~ 50 V <sub>DC</sub>	

- 1 Software and Industry Solutions
- 2 Industrial Server
- 3 Intelligent System
- 4 Intelligent HMI and Monitors
- 5 Automation Computers and Controllers
- 6 Industrial Communication
- 7 Remote I/O & Wireless Sensing Modules
- 8 Industrial I/O and Video Solutions



# IoT Wireless Sensor Nodes



Wireless		LPWAN				
Model Name		WISE-4210-AP	WISE-4210-S231	WISE-4210-S251	WISE-4210-S214	WISE-4210-S215
Description		LPWAN Wireless to Ethernet AP	LPWAN WSN with Temperature/Humidity Sensors	LPWAN WSN with 1-port RS-485 and 6-ch DI	LPWAN WSN with 4-ch AI and 4-ch DI	LPWAN WSN with 4-ch RTD
Wireless Interface	Function	Wireless Access Point	Wireless Sensor Node	Wireless Sensor Node	Wireless Sensor Node	Wireless Sensor Node
	IEEE Standard	IEEE 802.15.4g FSK/GFSK Modulation				
	Frequency Band	433, 868, or 923 MHz				
	Topology	Star				
	Outdoor Range	2000m (L.O.S.)				
Network	Configuration	RJ-45		Micro-B USB		
	Protocol	Modbus/TCP, REST, MQTT, Azure	-	-	-	-
Analog / Sensor Input	Channel	-	Built-in Sensors	-	4-ch	4-ch
	Input Type	-	Temperature, Humidity	-	V, A	2, 3-wire Pt RTD
	Input Range	-	-25°C ~ 70°C 0 ~ 90% RH	-	0~10V, 0~20mA, 4~20mA	Pt-100: -200~200°C Pt-1000: -40~160°C
Digital Input / Output	Channel	-	-	6-ch Dry Contact DI	4-ch Dry Contact DI	-
Serial Port	Port Number	-	-	1-port RS-485 for Modbus/RTU	-	-
Power Input	Battery Power	3 x AA, 3.6V V <sub>DC</sub> Lithium Battery				
	External Power	10 ~ 50 V <sub>DC</sub>		10 ~ 50 V <sub>DC</sub>		



Wireless		eMTC / NB-IoT				LPWAN
Model Name		WISE-4471-S250	WISE-4471-S214	WISE-4671-S672	WISE-4671-S614	PCM-24S1S1
Description		eMTC/NB-IoT WSN with 1-port RS-485 and DIO	eMTC/NB-IoT WSN with 4-ch AI and 4-ch DI	Outdoor eMTC/NB-IoT WSN with 2 Serial Port	Outdoor eMTC/NB-IoT WSN with 4-AI & 4-DI	LPWAN Wireless iDoor AP
Wireless Interface	Function	Wireless Sensor Node	Wireless Sensor Node	Wireless Sensor Node	Wireless Sensor Node	Wireless Access Point
	IEEE Standard	R13 LTE Cat M1 / NB1				
	Frequency Band	2, 3, 4, 5, 8, 12, 13, 20, 28				
	Topology	Star				
	Outdoor Range	2000m (L.O.S.)				
Network	Interface	Micro-B USB	Micro-B USB	Micro-B USB	Micro-B USB	mPCIe
	Protocol	UDP, CoAP, REST, MQTT	UDP, CoAP, REST, MQTT	UDP, CoAP, REST, MQTT	UDP, CoAP, REST, MQTT	Modbus/TCP, REST, MQTT
Analog / Sensor Input	Channel	-	4-ch	-	4-ch	-
	Input Type	-	V, A	-	V, A	-
	Input Range	-	0~10V, 0~20mA, 4~20mA	-	0~10V, 0~20mA, 4~20mA	-
Digital Input / Output	Channel	6-ch Dry Contact DI 2-ch Sink-type DO	4-ch Dry Contact DI	6-ch Dry Contact DI	4-ch Dry Contact DI	-
Serial Port	Port Number	1-port RS-485 for Modbus/RTU	-	1-port RS-485 1-port RS-232/485	-	-
Power Input	Battery Power	Solar Rechargeable Battery				
	External Power	10 ~ 50 V <sub>DC</sub>				

# ADAM-6217

# ADAM-6224

8-ch Isolated Analog Input Modbus TCP Module

4-ch Isolated Analog Output Modbus TCP Module



ADAM-6217



## Specifications

### Analog Input

- **Channels** 8 (differential)
- **Input Impedance** > 10 MW (voltage)  
120 W (current)
- **Input Type** mV, V, mA
- **Input Range** ±150 mV, ±500 mV, ±1 V, ±5 V, ±10 V, 0 ~ 20 mA, 4 ~ 20 mA, ±20 mA
- **Span Drift** ± 30 ppm/°C
- **Zero Drift** ± 6 µV/°C
- **Resolution** 16-bit
- **Accuracy** ± 0.1% of FSR (Voltage) at 25°C  
± 0.2% of FSR (Current) at 25°C
- **Sampling Rate** 10 sample/second (total)
- **CMR @ 50/60 Hz** 92 dB
- **NMR @ 50/60 Hz** 67 dB
- **Common Mode** 200 V<sub>DC</sub>

## Ordering Information

- **ADAM-6217** 8-ch Isolated Analog Input Modbus TCP Module

ADAM-6224



## Specifications

### Analog Output

- **Channels** 4
- **Output Impedance** 2.1 Ω
- **Output Settling Time** 20 µs
- **Driving Load** Voltage: 2kΩ  
Current: 500 Ω
- **Programmable Output Slope** 0.125 ~ 128 mA/sec  
0.0625 ~ 64 V/sec
- **Output Type** V, mA
- **Output Range** 0 ~ 5 V, 0 ~ 10 V, ± 5 V, ± 10 V, 0 ~ 20 mA, 4 ~ 20 mA
- **Accuracy** ± 0.3% of FSR (Voltage) at 25°C  
± 0.5% of FSR (Current) at 25°C
- **Resolution** 12-bit
- **Current Load Resistor** 0 ~ 500 Ω
- **Drift** ± 50 ppm/°C

### Digital Input

- **Channels** 4 (Dry Contact only)
- **Dry Contact** Logic 0: Open  
Logic 1: Closed to DGND

- **Support DI Filter**
- **Support Inverted DI Status**
- **Support Trigger to Startup or Safety Value**

## Ordering Information

- **ADAM-6224** 4-ch Isolated Analog Output Modbus TCP Module

## Common Specifications

### General

- **Ethernet** 2-port 10/100 Base-TX (for Daisy Chain)
- **Protocol** Modbus/TCP, TCP/IP, UDP, HTTP, DHCP
- **Connector** Plug-in 5P/15P screw terminal blocks
- **Power Input** 10 ~ 30 V<sub>DC</sub> (24 V<sub>DC</sub> standard)
- **Watchdog Timer** System (1.6 seconds)  
Communication (Programmable)
- **Dimensions** 70 x 122 x 27 mm
- **Protection** Built-in TVS/ESD protection  
Power Reversal protection  
Over Voltage protection: +/- 35V<sub>DC</sub>  
Isolation protection: 2500 V<sub>DC</sub>
- **Power Consumption** ADAM-6217: 3.5W @ 24 V<sub>DC</sub>  
ADAM-6224: 6W @ 24 V<sub>DC</sub>

### Features

- Daisy chain connection with auto-bypass protection
- Remote monitoring and control with smart phone/pad
- Group configuration capability for multiple module setup
- Flexible user-defined Modbus address
- Intelligent control ability by Peer-to-Peer and GCL function
- Multiple protocol support: Modbus TCP, TCP/IP, UDP, HTTP, DHCP, SNMP (ADAM-6217-B), MQTT (ADAM-6217-B)
- Web language support: XML, HTML 5, JavaScript
- System configuration backup
- User Access Control

### Environment

- **Operating Temperature** -10 ~ 70°C (14 ~ 158°F) ADAM-6224  
-40 ~ 70°C (-40~158°F) ADAM-6217-B
- **Storage Temperature** -20 ~ 80°C (-4 ~ 176°F) -40 ~ 80°C (-40~176°F)  
for ADAM-6217-B
- **Operating Humidity** 20 ~ 95% RH (non-condensing)
- **Storage Humidity** 0 ~ 95% RH (non-condensing)

# ADAM-6200 Series Selection Guide



Model	ADAM-6217	ADAM-6224	ADAM-6250	ADAM-6251	ADAM-6256	ADAM-6260	ADAM-6266
Interface	10/100Mbps Ethernet						
Peer-to-Peer <sup>1</sup>	✓	Receiver Only <sup>2</sup>	✓	✓	✓	✓	✓
GCL <sup>1</sup>	✓	✓	✓	✓	✓	✓	✓
Analog Input	Channels	8	-	-	-	-	-
	Input Impedance	>10M $\Omega$ (voltage) 120 $\Omega$ (current)	-	-	-	-	-
	Voltage Input	$\pm$ 150 mV, $\pm$ 500 mV, $\pm$ 1 V, $\pm$ 5 V, $\pm$ 10 V	-	-	-	-	-
	Current Input	0 ~ 20, 4 ~ 20, $\pm$ 20 mA	-	-	-	-	-
	Sampling Rate	10 Hz	-	-	-	-	-
	Direct Sensor Input	-	-	-	-	-	-
	Burnout Detection	✓ (4 ~ 20 mA)	-	-	-	-	-
	Resolution	16-bit	-	-	-	-	-
Accuracy	$\pm$ 0.1% of FSR (voltage) @ 25°C $\pm$ 0.2% of FSR (current) @ 25°C	-	-	-	-	-	
Analog Output	Channels	-	4	-	-	-	-
	Voltage Output	-	0 ~ 5, 0 ~ 10, $\pm$ 5, $\pm$ 10 V	-	-	-	-
	Current Output	-	0 ~ 20, 4 ~ 20 mA	-	-	-	-
	Resolution	-	12-bit	-	-	-	-
Digital I/O	Input Channels	-	4 (dry contact only)	8	16	-	4
	Output Channels	-	-	7 (sink)	-	16 (sink)	-
	Relay Output	-	-	-	-	-	6 (5 Form C + 1 Form A)
	Contact Rating	-	-	-	-	-	250 V <sub>AC</sub> @ 5A 30 V <sub>DC</sub> @ 5A
	Counter Input	-	-	3 kHz	3 kHz	-	-
	Frequency Input	-	-	3 kHz	3 kHz	-	-
	Pulse Output	-	-	5 kHz	-	5 kHz	5 kHz
LED Indicator	-	-	8 digital outputs, 7 digital inputs	16 digital inputs	16 digital outputs	6 relay	4 digital inputs, 4 relay
Power Consumption	3.5 W	6 W	3 W	2.7 W	3.2 W	4.5 W	4.2 W
Isolation Voltage	2,500 V <sub>DC</sub>						
Watchdog Timer	System (1.6 s) Communication (programmable)						
Communication Protocol	Modbus TCP, TCP/IP, UDP, HTTP, DHCP, MQTT, SNMP						
Power Requirements	10 ~ 30 V <sub>DC</sub> (24 V <sub>DC</sub> standard)						
Operating Temperature	-10 ~ 70°C (14 ~ 158°F)						
Storage Temperature	-20 ~ 80°C (-4 ~ 176°F)						
Operating Humidity	20 ~ 95% RH (non-condensing)						
Storage Humidity	0 ~ 95% RH (non-condensing)						

Note 1: Peer-to-peer and GCL cannot be run simultaneously; only one feature can be enabled at a time.

Note 2: The ADAM-6224 can only act as a receiver and generate analog output when peer-to-peer or GCL mode is used.

# ADAM-3600-C2G

## 8AI / 8DI / 4DO / 4-Slot Expansion Wireless Intelligent RTU

**NEW**

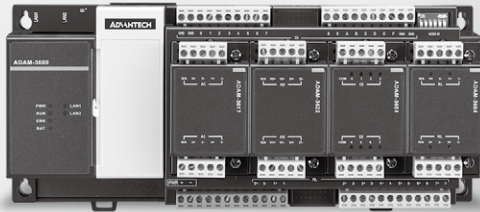

### Features

- High Performance CPU Cortex A8 600MHz
- Low Power DDR3L 256MB RAM
- Embedded Real-time Linux Kernel
- Domain Focused Onboard IO -8AI / 8DI / 4DO
- 4-Slot I/O Expansion
- High I/O Flexibility with 4-slot I/O Expansion
- Multiple wireless options for Zigbee/ Wi-Fi/ 3G/ 4G/ GPRS
- IEC61131-3&C Programming Language
- Modbus & DNP3 & IEC-60870-5-104
- Operation Temperature -40 ~ 70°C
- Internal Webpage for Online Monitoring
- Data Logger on SD card
- Support Azure IOT-Hub
- Support MQTT Client for cloud communication

### Introduction

ADAM-3600-C2G is a cloud ready intelligent Remote Terminal Unit with multiple wireless function capability, multiple I/O selection, wide temperature range and supports flexible communication protocol for oil, gas and water applications. In these application environments, ADAM-3600 is ideal for remote inhospitable regions with many devices that need to be managed remotely.

### Features

#### Wide Array of Flexible I/Os

Wide array of on-board I/O and flexible expansion I/O modules supporting different acquisition requirements giving it a high cost performance.



#### Wireless Communication & Protocols

The ADAM-3600 simultaneously supports two mini-PCIe cards (a half-size and a full-size) for Wi-Fi/ 3G/ GPRS/ Zigbee communication which is flexible for wiring in the field. Modbus RTU/TCP and DNP3 protocols integrate ADAM-3600 with more SCADA systems.



#### Wide Temperature Range

A -40 ~ 70°C operating temperature allows the ADAM-3600 to work in harsh environments and reduces maintenance costs for customers.



#### Remote Firmware Update

The ADAM-3600 can use a USB drive and an SD card to automatically update the firmware so there's no need to bring a computer and execute the configuration program in the field.

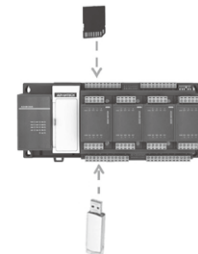

#### Intelligent Connectivity Diagnosis Manager (iCD Manager)

Remotely monitor serial and Ethernet port status and send alarm information during communication failures to help improve intelligent monitoring.

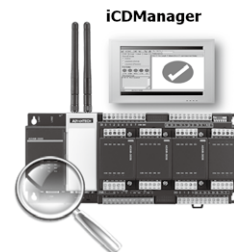

#### Node ID for Batch Configuration

Each ADAM-3600 has a node ID as its name to support batch configuration (max.64) with the configuration utility. When an alarm is displayed on the utility, customers can directly find the fault source with the node ID.



# ADAM-3600-C2G

## Specifications

### Control System

- **CPU** Cortex-A8 AM3352
- **Memory** RAM 256MB  
Battery Backup RAM 32KB
- **OS** RT-Linux V3.12
- **Storage** MicroSD card / 1GB included for system  
SD card slot / Optional
- **Programming** IEC-61131-3, Linux C
- **Watchdog** Yes
- **Real-time Clock** Yes
- **Power Input** 10 ~ 30 V<sub>DC</sub>
- **Power Consumption** 24V @ 5W

### Communication

- **Protocol** Modbus/TCP, DNP3 L2, TCP/IP, DHCP, IEC104, MQTT
- **Serial Port** 1 x RS232/485- DB9  
2 x RS485- Terminal Block
- **Ethernet Port** 2 x RJ-45 10/100 Mbps
- **USB Port** 1 x USB 2.0
- **VGA Port** 1 x D-SUB15
- **LED** System LEDs/ IO LEDs
- **Isolation** 2000 V<sub>DC</sub>
- **PLC driver support** Siemens/Mitsubishi/Omron/Allen-Bradley, Delta etc
- **Cyber Security** SSL, SSH, white list

### Analog Input

- **Channel** 8 differential
- **Resolution** 16-bit
- **Input Type** ±10V, ±2.5V, 0 ~ 20mA, 4 ~ 20mA
- **Isolation** 2,000 V<sub>DC</sub>

### Digital Input

- **Channel** 8
- **Input Type** Wet Contact
- **Protection Voltage** +40 V<sub>DC</sub>
- **Isolation** 2,000 V<sub>DC</sub>

### Digital Output

- **Channel** 4
- **Output Type** Open Collector (Sink)
- **Rated Voltage** 8 ~ 30 V<sub>DC</sub>
- **Isolation** 2,000 V<sub>DC</sub>

### Wireless Communication (Selectable)

- **Interface** Mini-PCle (1 x Half-Size / 1 x Full-Size)
- **Wireless Type** Zigbee- UART Signal  
Wi-Fi/3G/GPRS- USB Signal

### General

- **Certification** CE/FCC
- **Operating Temp.** -40 ~ 70°C
- **Storage Temp.** -40 ~ 85°C
- **Humidity** 5 ~ 95%(no-condensation)
- **Mounting** DIN 35 rail/ Wall Mount

### I/O Expansion Module Selection Table

Unit: Channels

Expansion Module	RTD	AI	T.C.	AO	DI	DO
ADAM-3613	4					
ADAM-3617		4				
ADAM-3618			4			
ADAM-3624				4		
ADAM-3651					8	
ADAM-3656						8

## Ordering Information

- **ADAM-3600-C2GL1A1E** 8AI/8DI/4DO/4-Slot Expansion Wireless Intelligent RTU

## Optional Accessory

### 3G/GPRS Solution (SIM card is not included)

- **EWM-C109F601E** 6-band HSPA Cellular Module with SIM Holder
- **1750006264** SMA(F) Cable, 15 cm
- **1750005865** Dipole Antenna, 11 cm

### WIFI Solution (recommended)

- **96PD-RYUW131** 2.4GHz Wi-Fi Full/Half Size Mini PCle Card
- **9656EWMG00E** Half to full-size Mini PCle bracket pack(optional)
- **1750006043** SMA(M) cable, 15 cm
- **1750000318** 2dBi antenna for testing, 11 cm

### GPS Solution

- **EWM-G108H01E** GPS/GNSS Half-MiniPCle card
- **1750006264** SMA (F) Cable, 15cm
- **1750006432** Antenna 4.5 dBi, 500cm

### Storage Solution

- **SQF-ISDS1-4G-82E** SLC 4G, 1CH (-40 ~ 85°C)
- **SQF-ISDS1-32G-82E** SLC 32G, 1CH (-40 ~ 85°C)

## Layout

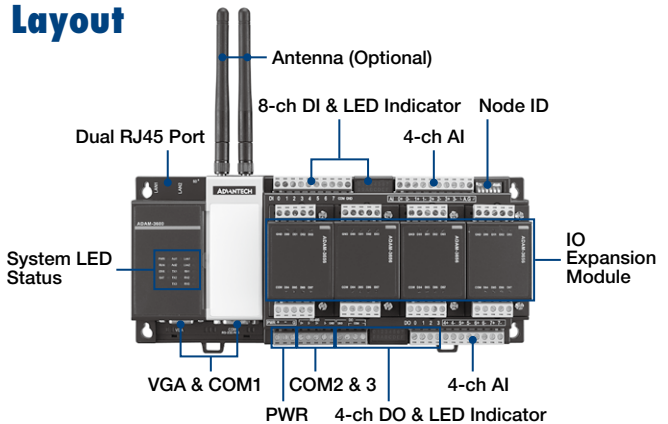

## Dimensions

Unit: mm

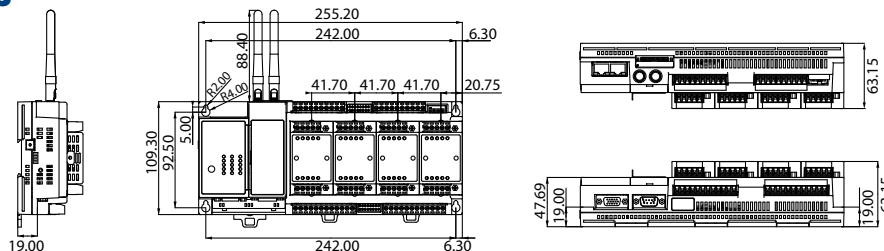

# WISE-PaaS / EdgeLink-Enabled Gateways



## Expansion Module for ADAM-3600

Model Name		ADAM-3600
Description		Open Basis Intelligent RTU
System	CPU	Cortex A8
	Operating system	Linux RT 3.12
	Programming interface	C (Linux) IEC-61131-3, IEC-60870-104
	Communication protocols	Modbus/RTU, Modbus/TCP, DNP3
	Wireless communication protocols	GPRS, LTE 3G, Wi-Fi, Zigbee
Serial Port	Special functions	Monitoring (iCDManager), data identification, breakpoint transmission, initiative reporting
	Number of ports	3
Network Port	Type	1 x RS-232/485, 2 x RS-485
	Number of channels	2
	Number of independent IP addresses	2
	Speed	10/100 Mbps
I/O	IP specifications	IPv4/IPv6
	Onboard I/O	8 analog inputs, 8 digital inputs, 4 digital outputs
USB	Expansion slots	4
	USB2.0	1
Display Interface	VGA	1
	LED	System, serial, Ethernet, digital I/O, programmable
Storage Interface	SD	1 x SD slot
Operating Temperature		-40~70 °C
Certification		CE/FCC
Part Number		ADAM-3600-C2GL1A1E

Model	Category	Channel	Part Number
ADAM-3617	Analog input module	4	ADAM-3617-AE
ADAM-3618	Analog input module	4, thermocouple	ADAM-3618-AE
ADAM-3624	Analog output module	4	ADAM-3624-AE
ADAM-3651	Digital input module	8	ADAM-3651-AE
ADAM-3656	Digital output module	8	ADAM-3656-AE
ADAM-3613	Analog input module	4, RTD	ADAM-3613-AE

Analog Input	
Signal Input	Differential
Sampling Rate	10 Hz
Voltage Input	+/- 10 V, +/- 2.5 V
Input Current	0~20 mA, 4~20 mA
Sensor Input	Thermocouple (type J, K, T, E, R, S, B) RTD (Pt100, Pt1000, Balco 500, Ni 518)
Resolution	16-bit

Analog Output	
Output Voltage	0~10 V
Output Current	0~20 mA, 4~20 mA
Resolution	12-bit

Digital Input	
Input Type	Sink
Rated Voltage	12/24 V <sub>DC</sub>
Logic "0" Voltage	0~5 V <sub>DC</sub>
Logic "1" Voltage	11~30 V <sub>DC</sub>

Digital Output	
Output Type	Open collect
Output Voltage	8~30 V <sub>DC</sub> @ max 200 mA

## Wireless Expansion Module



### EWM-W150H2E

Half-sized mini card, supports 802.11bgn

1750006043	SMA(M) cable, 15 cm
1750000318	2-dBi antenna, 11 cm



### EWMC109F601E

6-band HSPA cellular module with SIM holder

1750006264	SMA(F) cable, 15 cm
1750005865	Dipole antenna, 11 cm

# ADAM-5630

## Edge Intelligent DAQ Controller



### Features

- Support Modbus/RTU, Modbus/TCP Master and Slave function libraries
- Support Web server for I/O configuration and monitoring
- C and Python programming based on Linux operating system
- Built-in real-time clock and watchdog timer
- 1 micro SD slot expansion for data storage
- 4 serial communication ports onboard
- 2 Ethernet Ports
- 4 or 8 I/O slot expansion

### Specifications

#### Control System

- **CPU** TI Cortex-A8 AM3352 600MHz
- **Memory** RAM 512M
- **Battery memory** 128K
- **OS** RT-Linux V3.12, WEC7
- **Storage** 1 x 512M Flash (System)  
1 x Micro-SD (Storage)
- **Programming** Linux C, Python
- **Watch dog** Yes
- **I/O Slot** Optional 8 or 4 slots
- **LED Indicators** Power, CPU, BAT
- **Display** VGA
- **USB** 2 x USB 2.0

#### Serial Communication

- **Max. Nodes** 256 (in RS-485 daisy-chain network)
- **Distance** 1.2Km (4,000feet in RS-485 mode)
- **Speed** 50-115.2kbps
- **Isolation** 2500 V<sub>DC</sub> (COM1,2,3 only)
- **Connector** COM1: Screw terminal (2-PIN RS-232/485)  
COM2: Screw terminal (RS-485)  
COM3: Screw terminal (RS-485)  
COM4: DB9-M (RS-232/485)

#### Ethernet Communication

- **Connector** 2 x RJ45
- **Distance** 100 m
- **Speed** 10/100/1000 Base-T

#### Power Consumption

- **Power Consumption** 8W
- **Power input** 10 ~ 30 V<sub>DC</sub>
- **Reverse Protection** Yes

#### General

- **Certification** CE,FCC Class A
- **Dimensions** 4-slots 231 x 110 x 75 mm  
8-slots 355 x 100 x 75 mm
- **Enclosure** ABS-PC
- **Mounting** DIN-rain, stack, wall

#### Wireless (Plug-in Extension)

- **Interface** Mini-PCIe (USB Signal)  
M2.COM(UART Signal)
- **Wireless Type** Zigbee- UART Signal  
Wi-Fi/3G/GPRS- USB Signal

#### Environment

- **Humidity** 5 ~ 95% non-condensing
- **Operating Temperature** -40 ~ 70°C
- **Storing Temperature** -40 ~ 85°C

### Order information

- **ADAM-5630-AE** 4-slot RISC-based Modular DA&C Controller
- **ADAM-5630E-AE** 8-slot RISC-based Modular DA&C Controller

1

Software and Industry Solutions

2

Industrial Server

3

Intelligent System

4

Intelligent HMI and Monitors

5

Automation Computers and Controllers

6

Industrial Communication

7

Remote I/O Modules

8

Industrial I/O and Video Solutions

# ADAM-5000 Controller Selection Guide



System		ADAM-5630	ADAM-5630E	ADAM-5510/TCP ADAM-5510KW/TCP	ADAM-5510E/TCP ADAM-5510EKW/TP	ADAM-5560
CPU		cortex A8 600 MHz	cortex A8 600 MHz	80188		Intel Atom Z510P 1.1 GHz
RAM		512 MB DDR3L	512 MB DDR3L	640 KB		1 GB DDR2 SDRAM
Flash ROM		N/A	N/A	256 KB		-
Flash Memory		N/A	N/A	256 KB		-
Flash Disk		1 GB	1 GB	1 MB		-
OS		RT-Linux	RT-Linux	ROM-DOS		WinCE5.0/XP embedded
Control Software		Linux C SDK	Linux C SDK	ADAM-5510/TCP: Borland C ADAM-5510KW/TCP: KW SoftLogic	ADAM-5510E/TCP: Borland C ADAM-5510EKW/TP: KW SoftLogic	ADAM-5560CE: C/C++ and .NET ADAM-5560KW: KW SoftLogic
Real-time Clock		YES	YES	Yes		
Watchdog Timer		YES	YES	Yes		
COM1		RS-232/485	RS-232/485	RS-232	RS-232/RS-485	RS-232/485
COM2		RS-485	RS-485	RS-485		
COM3		RS-485	RS-485	RS-232 (TX, RX, GND)		RS-232/485
COM4		RS-232/485	RS-232/485	RS-232/485		
I/O Slots		4	8	4	8	7
Power Consumption		8W (for 5630 series only)		8 W		17 W
Isolation	Communication	2500 V <sub>DC</sub> (COM1~COM3) (for 5630 series only)		2,500 V <sub>DC</sub> (COM2 RS-485)		2,500 V <sub>DC</sub> (COM2 RS-485) 1,500 V <sub>DC</sub> (COM1, COM3, COM4 RS-485)
	Communication Power			3,000 V <sub>DC</sub>		
	I/O Module			3,000 V <sub>DC</sub>		
Diagnosis	Status Display	Power, RUN, Error, BAT, user define (for 5630 series only)		Power, CPU, Communication, Battery		Power, User Define
	Self Test			Yes, while ON		
	Software Diagnosis			Yes		
Communication	Interface	RS-232/485		Ethernet (RJ-45)		Ethernet (2 x RJ-45)
	Speeds	300 bps ~ 115.2 kbps		10/100 Mbps		10/100 Mbps
	Max. Distance	4,000 feet (1.2 km)		100 m		100 m
	Max. Nodes	32	32	256 for Ethernet, 32 for RS-485	256 for Ethernet, 32 for RS-485	256 for Ethernet, 32 for RS-485
	Protocol	User Defined, Modbus/RTU	User Defined, Modbus/RTU	User Defined, Modbus/ RTU, Modbus/TCP	User Defined, Modbus/ RTU, Modbus/TCP	Modbus/RTU, Modbus/TCP
	Remote I/O			Modbus Device		
	Power Requirements			10 ~ +30 V <sub>DC</sub>		
Environment	Operating Temperature	-20 ~ 70°C		-10 ~ 70°C (14 ~ 158°F)		0 ~ 55°C (32 ~ 131°F)
	Storage Temperature			-25 ~ 85°C (-13 ~ 185°F)		
	Humidity			5 ~ 95%		
Dimensions (mm)		231 x 110 x 75	355 x 110 x 75	231 x 110 x 75	355 x 110 x 75	355 x 110 x 75



# ADAM-6717UH

## ADAM-6750

## ADAM-6771



Back to TOC



Previous



Next



Data Analytics Gateway with High-Speed Analog Input

Data Analytics Gateway with Digital I/O

Data Analytics Gateway



ADAM-6717UH

### Specifications

#### General

- **CPU** Cortex-A8 32-Bit 1GHz
- **Memory** NAND flash 512MB
- **RAM** DDR3L 1024MB
- **Storage** microSD 1GB (optional)
- **OS** Real-time Linux V3.12
- **Programming** Node-red, Linux C
- **Power input** 10 ~ 50 V<sub>DC</sub>
- **Operation temperature** -30 ~ 70°C
- **Storage temperature** -40 ~ 80°C

#### Communication

- **LAN** 2 x RJ-45 10/100 Mbps

#### Analog Input

- **Channels** 8 (differential)
- **Sampling Rate** 100K sample/ second (total)

#### Digital Output

- **Channels** 1
- **Output type** open collector (sink) to 50 V<sub>DC</sub>

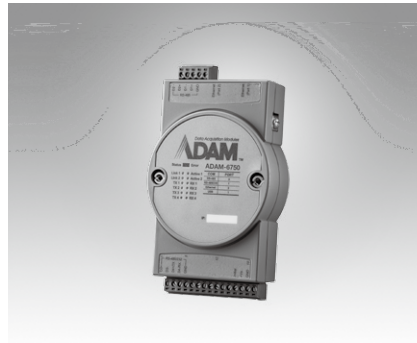

ADAM-6750

### Specifications

#### General

- **CPU** Cortex-A8 32-Bit 1GHz
- **Memory** NAND flash 512MB
- **RAM** DDR3L 1024MB
- **Storage** microSD 1GB (optional)
- **OS** Real-time Linux V3.12
- **Programming** Node-red, Linux C
- **Power input** 10 ~ 50 V<sub>DC</sub>
- **Operation temperature** -30 ~ 70°C
- **Storage temperature** -40 ~ 80°C

#### Communication

- **LAN** 2x RJ-45 10/100 Mbps
- **Serial** 1 x RS-485

#### Digital Input

- **Channels** 8 support 3KHz counter input
- **Dry contact** logic 0 close to ground logic 1 Open
- **Wet contact** logic 0: 0 ~ 5 V<sub>DC</sub> logic 1: 10 ~ 50 V<sub>DC</sub>

#### Digital Output

- **Channels** 4
- **Output type** Open collector (sink) to 50 V<sub>DC</sub>

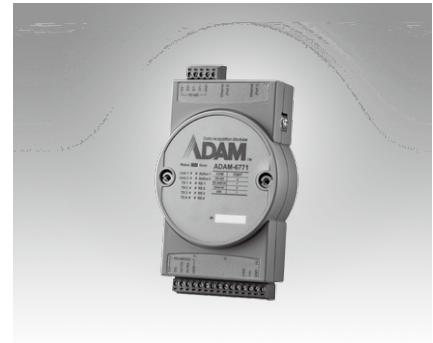

ADAM-6771

### Specifications

#### General

- **CPU** Cortex-A8 32-Bit 1GHz
- **Memory** NAND flash 512MB
- **RAM** DDR3L 1024MB
- **Storage** microSD 1GB (optional)
- **OS** Real-time Linux V3.12
- **Programming** Node-red, Linux C
- **Power input** 10 ~ 50 V<sub>DC</sub>
- **Operation temperature** -30 ~ 70°C
- **Storage temperature** -40 ~ 80°C

#### Communication

- **LAN** 2 x RJ-45 10/100 Mbps
- **Serial** 2 x RS-485 2 x RS-485/232
- **USB** 1 x USB 2.0

1

Software and Industry Solutions

2

Industrial Server

3

Intelligent System

4

Intelligent HMI and Monitors

5

Automation Computers and Controllers

6

Industrial Communication

7

Remote I/O Modules

8

Industrial I/O and Video Solutions

# ADAM-6700 Series Selection Guide



		ADAM-6750	ADAM-6717UH	ADAM-6771
CPU		ARM Cortex-A8 32-Bit 1GHz		
Memory		NAND flash 512MB		
RAM		DDR3L 512MB		
External storage		1GB microSD (Optional)		
OS		Real-time Linux V3.12		
Programming		Node-Red(Graphic programming environment based on javascript),Linux C		
Interface	RS-485	1		2
	RS-485/232			2
	LAN	2	2	2
	USB 2.0			1
Digital input	Channel	8		
	Type	Dry contact: logic 0 close to ground logic 1 Open  Wet contact: logic 0: 0 ~ 5 V <sub>DC</sub> logic 1: 10 ~ 50 V <sub>DC</sub>		
	Counter input	3kHz		
Digital Output	Channel	4	1	
	Voltage	0 ~ 50 V <sub>DC</sub>	0 ~ 50 V <sub>DC</sub>	
	Type	Sink	Sink	
Analog input	channel		8	
	Sampling rate	100kHz (total)		
Dimension		70W x 122L x 27H mm		

# WISE-6610

## Industrial LoRaWAN Gateway



### Features

- Long-range wide area IoT gateway
- LoRaWAN protocol for closed and public system application
- Ethernet and I/O for connecting a wide array of field assets
- DIN rail and wall mounting design
- Low power consumption for solar and battery power applications
- Enhanced memory for hosting custom software applications
- Redundancy-enhanced functions for continuous data transmission

### Introduction

The WISE-6610 is a high-performance LoRaWAN gateway that offers reliable connectivity for industrial environments. It supports the LoRaWAN protocol for building LoRaWAN private and public networks, as well as various protocols including MQTT. The hardware and software flexibility of the WISE-6610 provides rich features for edge intelligence systems, and its support for VPN tunneling with various protocols ensures safe communications. The WISE-6610 also provides a network server that can phase the LoRaWAN data in our device. The WISE-6610 provides the redundancy-enhanced functions to prevent connection loss.

### Specifications

#### WSN Support

- **Standard** LoRaWAN
- **Frequency** 868/915 MHz
- **ANT Connector** RP-SMA Female connector x 1

#### LAN Interface

- **Ethernet** 10/100 Mbps, auto MDI/MDIX
- **Connector** 1 x RJ45
- **Protection** 1.5-kV built-in magnetic isolation protection

#### Digital I/O

- **Port Type** 1x Digital Input On Voltage: 2.7V to 36V<sub>DC</sub>
- **Port Connector** 4-way Molex mini-fit connector

#### General

- **LED Indicators** PWR, DAT, WAN, ETH
- **Reboot Trigger** Reset button

#### Software

- **Network and Routing** DHCP server, NAT/PAT, VRRP, dynamic DNS client, DNS proxy, VLAN, QoS, DMVPN, NTP client/server, IGMP, BGP, OSPF, RIP, SMTP, SMTPS, SNMP v1/v2c/v3, backup routers, PPP, PPPoE, SSL, port forwarding, host port routing, Ethernet bridging, network server
- **Configuration** SSH, Web Browser
- **Network Security** HTTPS, SSH, VPN tunnels, SFTP, DMZ, firewall (IP filtering, MAC address filtering, inbound/outbound port filtering)
- **VPN tunnelling** Open VPN client and server and P2P, L2TP, PPTP, GRE, EasyVPN, IPSec with IKEv1 and IKEv2

#### Cellular Interface (WISE-6610-E100W-A/E500W-A Only)

- **LTE** Bit rate: 150 Mbps (DL), 50 Mbps (UL)
- **LTE Bands** B20 (800 MHz), B8 (900 MHz), B3 (1800 MHz), B1 (2100 MHz), B7 (2600 MHz)
- **3G** Bit rate: 42.0 Mbps (DL), 5.76 Mbps (UL)
- **3G Bands** 900, 2100 MHz
- **No. of SIM Slots** 2
- **ANT Connector** 2 x RP-SMA female connectors

#### Mechanics

- **Dimensions (W x H x D)** 150 x 30 x 83 mm (5.9" x 1.18" x 3.27")
- **Mounting** DIN rail, wall
- **Weight** 500g
- **Enclosure Rating** IP30

#### Power Requirements

- **Power Input** 9 ~ 36 V<sub>DC</sub>
- **Power Connector** 4-way Molex mini-fit connector
- **Power Consumption** 3.1/6.6/40 mW (average/peak/sleep mode)

#### Environment

- **Operating Temperature** -40 ~ 75°C
- **Storage Temperature** -40 ~ 85°C
- **Operating Humidity** 10 ~ 95% RH

- 1 Software and Industry Solutions
- 2 Industrial Server
- 3 Intelligent System
- 4 Intelligent HMI and Monitors
- 5 Automation Computers and Controllers
- 6 Industrial Communication
- 7 Remote I/O Modules
- 8 Industrial I/O and Video Solutions

## Dimensions

Unit: mm

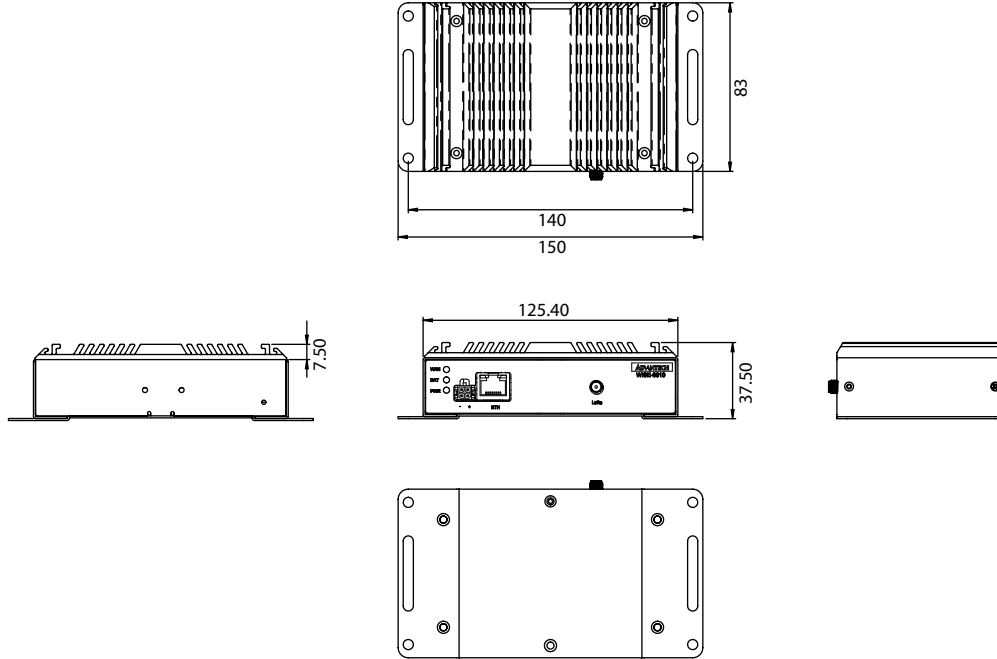

### Regulatory Approvals

- **EMC**
  - EN61000-4-2, Level 3
  - EN61000-4-3, Level 3
  - EN61000-4-4, Level 3
  - EN61000-4-5, Level 3
  - EN61000-4-6, Level 3
  - EN61000-4-12, Level 3
  - EN61000-4-11, voltage dip: 70%
- **Shock** IEC 60068-2-27
- **Free Fall** IEC 60068-2-32
- **Vibration** IEC 60068-2-6

### Ordering Information

- **WISE-6610-N100-A** LoRaWAN gateway supports up to 100 nodes with 915 MHz
- **WISE-6610-E100-A** LoRaWAN gateway supports up to 100 nodes with 868 MHz
- **WISE-6610-N500-A** LoRaWAN gateway supports up to 500 nodes with 915 MHz
- **WISE-6610-E500-A** LoRaWAN gateway supports up to 500 nodes with 868 MHz
- **WISE-6610-E100W-A** LoRaWAN Cellular Gateway support up to 100 nodes with 868MHz
- **WISE-6610-E500W-A** LoRaWAN Cellular Gateway support up to 500 nodes with 868MHz

# Wzzard LRPv Node

## Industrial LoRa Private Node



### Features

- Long-range wide area IoT gateway
- Optional solar or battery power input for low power consumption
- LoRa private protocol for closed system applications
- Ethernet and I/O ports for connecting a wide range of field assets with a DIN rail or wall mounting design
- Provides connectivity to industry standard analog or digital sensors
- Rugged, IP66-rated, fiber-reinforced polyester PBT enclosure
- MQTT and JSON IoT protocol support

### Introduction

The Wzzard LoRa private node intelligent sensor platform enables you to quickly and easily create a complete connectivity stack between your sensors and applications via either a network or the Internet. The platform uses intelligent edge nodes and a wireless LoRa network to transmit sensor data to the SmartSwarm 243 LoRa Gateway, which can connect to the Internet via a wired connection and communicate with application platforms using MQTT and JSON protocols. Wzzard LoRa intelligent edge nodes can accommodate virtually any industry standard external sensors. Connections can be made via conduit fittings, cable glands, or an M12 connector. These nodes provide various sensor interface options including general purpose analog inputs, digital input/output, and thermocouples.

### Specifications

#### Power

- **Internal** Two 3.6-V 2400-mAh lithium thionyl chloride AA batteries
- **Optional External Input** 6 ~ 12 V<sub>DC</sub> Voltage

#### Mechanical

- **Physical Connection** M12 12.7-mm (1/2") conduit, sensor interface cable included; 8-wire, 26-gage, 1.8-m (6")
- **Sensor Inputs** Analog input (0 ~ 5 V<sub>DC</sub>, 0 ~ 20 mA, 4 ~ 20 mA), digital input (0 ~ 48 V<sub>DC</sub>)  
Integrated temperature, thermocouple K-type digital output (0 ~ 30 V<sub>DC</sub>)
- **Optional External Antenna** RP-SMA, omnidirectional, 1.5 dBi, 868 ~ 915 MHz; length, 170 mm (6.69")
- **Mounting** Magnetic mounting via an internal magnet  
Holding force, 2.13 kg (4.7 lbs); four mounting ears, M5 (#10)
- **Enclosure** IP66-rated, fiber-reinforced polyester PBT
- **Weight** 400g

#### Technology

- **Wireless** LoRa private 868/915 MHz
- **LED** Network connectivity

#### Environmental

- **Installation** Indoor or outdoor
- **Operating Temperature** -40 ~ 75 °C (-40 ~ 167 °F)
- **Storage Temperature** -40 ~ 85 °C (-40 ~ 185 °F)
- **Operating Humidity** 10 ~ 95% noncondensing

#### Digital Inputs

- **Voltage Range** 0 ~ 48 V<sub>DC</sub>
- **V<sub>IL</sub>** 0.97 V (max)
- **V<sub>IH</sub>** 1.8 V (min)
- **Pull-Up Current** 32 μA
- **Type** Source/Sink (PNP/NPN) software-selectable input
- **Isolation** None

#### Analog Inputs

- **Input Range** 0 ~ 5 V<sub>DC</sub>, 0 ~ 20 mA, 4 ~ 20 mA
- **Resolution** 12 bit
- **Input Load Resistance** 100 MΩ (0 ~ 5 V<sub>DC</sub>), 250 Ω, (0 ~ 20 mA)
- **Accuracy** ±1% (Voltage) at 25 °C  
±1% (Current) at 25 °C

#### Thermocouple Input

- **Types Supported** K
- **Ranges Supported** Type-K -270 ~ 1372 °C (-454 ~ 2502 °F)
- **Resolution** 0.25 °C (34.25 °F)
- **Accuracy** ≤ 0 °C: ±2.5 °C  
> 0 °C: ±1.5 °C

#### Digital Outputs

- **Voltage Range** 0 ~ 30 V<sub>DC</sub>
- **Output Type** Open drain
- **Output Current** 100 mA (min)
- **Protection** Current limit protection
- **Isolation** None

# Wzzard LRPv Node

## Dimensions

Unit: mm [inch]

### BB-WSL2CXXXXX-X

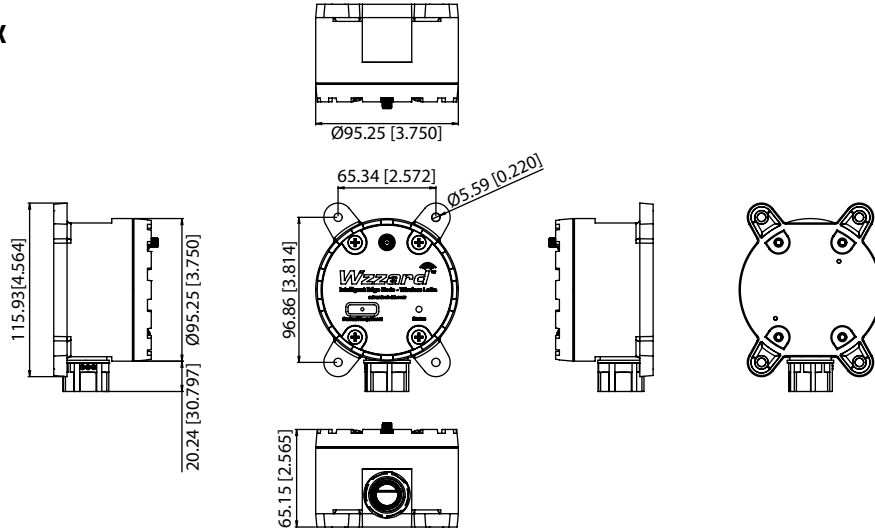

### BB-WSL2MXXXXX-X

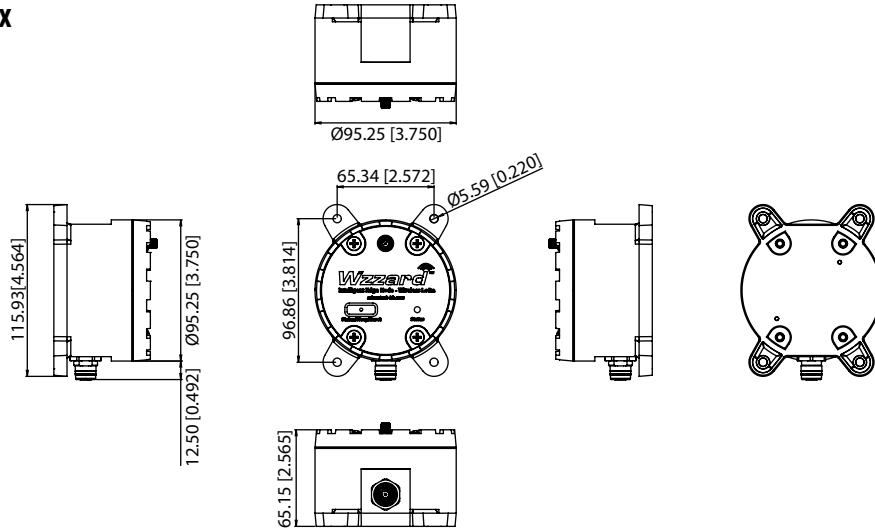

**Outline Dimension: 95.25 x 65.15 x 115.9 [3.75 x 2.56 x 4.56]**

- 1 Software and Industry Solutions
- 2 Industrial Server
- 3 Intelligent System
- 4 Intelligent HMI and Monitors
- 5 Automation Computers and Controllers
- 6 **Industrial Communication**
- 7 Remote I/O Modules
- 8 Industrial I/O and Video Solutions

### Regulatory Approvals

- Shock IEC60068-2-27
- Free Fall IEC60068-2-32
- Vibration IEC60068-2-6

### Ordering Information

- **BB-WSL2C2112T-1** LoRa node with power monitoring, 2 x thermocouples, 2 x AI, 1 x DI, 1 x DO, conduit, external antenna (915 MHz)
- **BB-WSL2C2112T-2** LoRa node with power monitoring, 2 x thermocouples, 2 x AI, 1 x DI, 1 x DO, conduit, external antenna (868 MHz)
- **BB-WSL2C31000-1** LoRa node with power monitoring, 3 x AI, 1 x DI, conduit, external antenna (915 MHz)
- **BB-WSL2C31000-2** LoRa node with power monitoring, 3 x AI, 1 x DI, conduit, external antenna (868 MHz)
- **BB-WSL2M31000-1** LoRa node with power monitoring, 2 x AI, 1 x DI, M12, external antenna (915 MHz)
- **BB-WSL2M31000-2** LoRa node with power monitoring, 3 x AI, 1 x DI, M12, external antenna (868 MHz)

# Industrial Wireless and Protocol Gateway Solutions

## Ethernet to Serial Converters



Model Name		VESP211, VESP211-232, VESP211-485	VESR901	VESR921-MC	MESR901	MESR921-MC
Description		Compact Ethernet to Serial Converter	DIN Rail Mount Ethernet to Serial Converter	DIN Rail Mount Ethernet to Serial Converter with Fiber Port	Modbus Ethernet to Modbus Serial Converter	Modbus Ethernet to Modbus Serial Converter with Fiber Port
Function		VCOM, Socket Connection, Paired Mode			Modbus	
Ethernet	Copper Ports	1	1	1	1	1
	Fiber Ports	-	-	1 Multi-mode (SC)	-	1 Multi-mode (SC)
Serial	Port Count	1	1	1	1	1
	DB9	232	232	232	232	232
	Terminal Block	422/485	422/485	422/485	422/485	422/485
Specifications	Temp Spec	-40 to 80°C	-40 to 80°C	-40 to 80°C	-40 to 80°C	-40 to 80°C
	Power DC	10 to 30V <sub>DC</sub>	10 to 48V <sub>DC</sub>	10 to 48V <sub>DC</sub>	10 to 48V <sub>DC</sub>	10 to 48V <sub>DC</sub>
	Mounting	Panel	DIN	DIN	DIN	DIN
	Class 1 Division 2	-	✓	✓	✓	✓

## Wireless Sensing Network



## Industrial Cellular Router



Model Name		Wizzard-LRPv Sensor Node	Wizzard	SmartStart	SmartFlex	SmartSwarm 243	WISE-6610
Part Number		BB-WSLxxxxxx	BB-WSDxxxx	BB-SL306x0110-SWH	BB-SR30xxxxxx	BB-SG30000115-43	WISE-6610-XX00-A
Description		Industrial LoRa Private Node	Intelligent Wireless Sensor Node	Intelligent LTE Router	Flexible, Module LTE Router	Industrial LoRa Private Gateway	LoRaWAN Gateway support up to 100/500 nodes with 868/915MHz
Specifications	Mobile Wireless	LoRa	DUST/BLE	GPRS/3G/LTE/WiFi	GPRS/3G/LTE/WiFi	LoRa	LoRaWAN
	Communication Interface	A/DI/DO	A/DI/DO	ETH/RS232/IO	ETH/SD/USB/IO/RS232&485/POE	ETH/IO	LoRaWAN
	Temp	-40~75 °C	-40~80 °C	-40~75 °C	-40~75 °C	-40~75 °C	-40~75 °C
	Power Input	3.3 V <sub>DC</sub>	3.3 V <sub>DC</sub>	9 -36 V <sub>DC</sub>	10 -69 V <sub>DC</sub>	9 -36 V <sub>DC</sub>	9~36 V <sub>DC</sub>
	Dimensions (W x H x D)	95 x 116 x 65 mm	95 x 116 x 65 mm	30 x 87 x 127 mm	55 x 97 x 125 mm	30 x 87 x 127 mm	150 x 30 x 83 mm
Weight		340g	340g	187g	375g	187g	187g

✓ : supported, - : not supported, △ : optional