

BALDOR® • RELIANCE 

Product Information Packet

IDBRPM18154C

15HP,1760RPM,3PH,60HZ,1844C,TEBC,FT/250

Part Detail							
Revision:	-	Status:	PRD/A	Change #:		Proprietary:	No
Type:	AC	Elec. Spec:	L3220A	CD Diagram:	422927-001	Mfg Plant:	
Mech. Spec:		Layout:	617232-023	Poles:	04	Created Date:	04-10-2015
Base:		Eff. Date:	04-13-2015	Leads:			

Specs			
Catalog Number:	IDBRPM18154C		
Enclosure:	TEBC		
Frame:	FL1844CZ		
Frame Material:	Aluminum		
Output @ Frequency:	15.000 HP @ 60 HZ		
Synchronous Speed @ Frequency:	1800 RPM @ 60 HZ		
Voltage @ Frequency:	460.0 V @ 60 HZ		
Agency Approvals:	CCSA US		
Auxillary Box:	No Auxillary Box		
Base Indicator:	Rigid		
Bearing Grease Type:	Polyrex EM (-20F +300F)		
Current @ Voltage:	21.000 A @ 460.0 V		
Duty Rating:	CONT		
Feedback Device:	NO FEEDBACK		
Frame Prefix:	FL		
Heater Indicator:	No Heater		
Insulation Class:	H		
Mounting Arrangement:	F3		

Product Family:	General Industrial		
Pulley End Bearing Type:	Ball		
Pulley Face Code:	C-Face		
Shaft Ground Indicator:	No Shaft Grounding		
Shaft Rotation:	Reversible		
Motor Standards:	NEMA		
Thermal Device - Bearing:	NONE (OLD)		
Thermal Device - Winding:	Normally Closed Thermostat		

Nameplate 000613006NS										
	DUTY	HP	RPM	AMPS	VOLTS	HZ				
	CONT	15	1760	21	460	60				
	CONT	15	3510	19	460	120				
CAT.NO.	IDBRPM18154C		SPEC. NO.		P18T0359					
SER.NO.			FR	FL 1844CZ	INSUL	H				
PH.	3		MAX SAFE SPEED	7200	AMB.	40		MIN. AMB.	0	
DESIGN NO.	L3220A		TYPE		ENCL.	TEAO-BC				
S.F.	1.0		D.E. BRG.	45BC02JPP30A						
ENCL MOD			O.D.E. BRG.	35BC02JPP30A						

Parts List		
Part Number	Description	Quantity
WS286783	WS P18T0359	1.000 EA
RA282991	RA P18T0359	1.000 EA
000613006NS	RPM AC WITH CERTIFIED LOGO	1.000 EA
000692000FP	NP, WARNING LIFT INSTRUCTIONS	1.000 EA
000692000NH	LABEL DIRECTION AIR FL	1.000 EA
036170004EA	ROUND HEAD DRIVE SCREW	4.000 EA
411716004A	219P039 - 219P039 - LA	1.000 EA
418056062A	NP AC BLOWER DATA	1.000 EA
422927001	C/D LABEL	1.000 EA
032003168CB	THRU BOLT	4.000 EA
033102012AG	HXNUT LEAD CONN	4.000 EA
034017012AB	LCKW 1/4 STD. PLATED	4.000 EA
036000050JB	M8-1,25 X 50 MHHCS	2.000 EA
400638001D	WAVEN (Customer number 43699)	1.000 EA
411693051B	LUG, LIFTING	2.000 EA
HA4054	SHORT T-DRAIN FITTING, .125" N.P.T.	1.000 EA
HA4054	SHORT T-DRAIN FITTING, .125" N.P.T.	1.000 EA
807580002BAA	BRKT,DE,FL181 807580-1WCC	1.000 EA
807580003AAB	BRKT,ODE180AC 807580-1WCC	1.000 EA
036000012HB	HHCS M6X12MM LONG PLATED	2.000 EA
036000012HB	HHCS M6X12MM LONG PLATED	3.000 EA
036000025JB	HHCS M8X25MM LONG PLATED	4.000 EA
036620009AB	M8 EXTERNAL LK WASHER	1.000 EA
065530000B	GASK	1.000 EA

Parts List (continued)		
Part Number	Description	Quantity
075451000A	COVER, CONDUIT BOX	1.000 EA
406673002C	.75 CAP PLUG	2.000 EA
415000103G	TLUG	1.000 EA
417733001A	GSK C/ BOX BASE	2.000 EA
418010006B	PLATE, MOUNTING	1.000 EA
418018074A	GROUND LABEL G100 METRIC 160 D.C.	1.000 EA
418057260A	SCREW PHILLIPS PAN HD	4.000 EA
418057373A	SCREW SHEET METAL	3.000 EA
613450011A	BLMTR SQ AC 210	1.000 EA
706320003A	CONDUIT BOX	1.000 EA
807505050A	COVER, FAN	1.000 EA
807505051A	GRILL, FAN COVER	1.000 EA
418057243A	GROOVE PIN	1.000 EA
807504052C	FL180 FRAME	1.000 EA
000640000P	TAG WINDING THERMOST	1.000 EA
004824007K	SPECIAL PAINT	0.100 EA
034180022FA	KEY 3/8X3/8X2-3/4 L	1.000 EA

REL S.O.	-	VOLTS	460	ENCLOSURE	TEBC	WYE	CONN EQ	CKT OHMS	PER PHASE
FRAME	F11844	AMPS	21	MAX SAFE RPM	7200	(AT BASE RATING, 25 °C)			
HP	15	DUTY	CONT	IM (AMPS)	12	R1	.348	X1	1.18
BASE SPEED	1760	S.F.	1.0	P.F. @NL/FL	.061/.776	R2	.245	X2	1.31
PHASE/HERTZ	3/60	AMB °C/INSUL	40/H	WK ² (lb-ft ²)	.645			XM	22.9

RATED FULL LOAD DATA

	RPM	HP	TORQUE LB-FT	FUND VOLTS	FREQ-HZ	AMPS
BASE SPEED	1759	15.0	45	460	60	20.7
MAX SPEED	3657	15.0	22	460	125	18.4
MIN SPEED	0	0	45	20.7	1.36	20.7

LOAD PERFORMANCE AT BASE SPEED

	RPM	HP	TORQUE LB-FT	FUND VOLTS	FREQ-HZ	AMPS
NO LOAD	1800	0	0	460	60	11.7
1/4	1791	3.76	11	460	60	12.7
1/2	1781	7.50	22	460	60	14.4
3/4	1770	11.3	33	460	60	17.3
FULL LOAD	1759	15.0	45	460	60	20.7
O/L	1706	29.1	90	460	60	38.1

REMARKS: TYPICAL DATA

 <p>A MEMBER OF THE ABB GROUP</p>	DR. BY	B. GRANT	<p>A-C MOTOR PERFORMANCE DATA</p> <p>I3220A ISSUE DATE 3-7-06</p>
	CR. BY	B. GRANT	
	APP. BY	T. CUER	
	DATE	3-7-06	

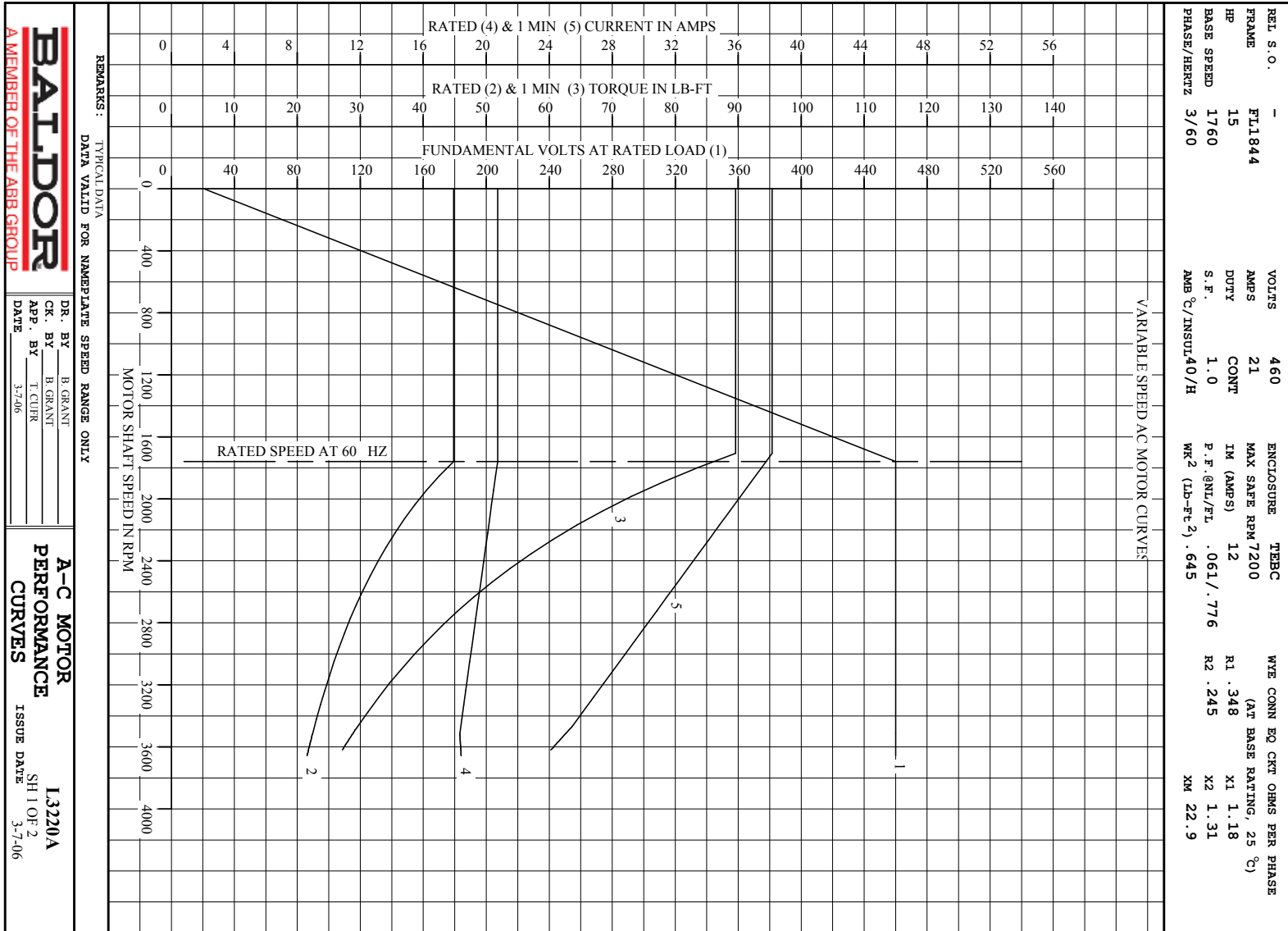

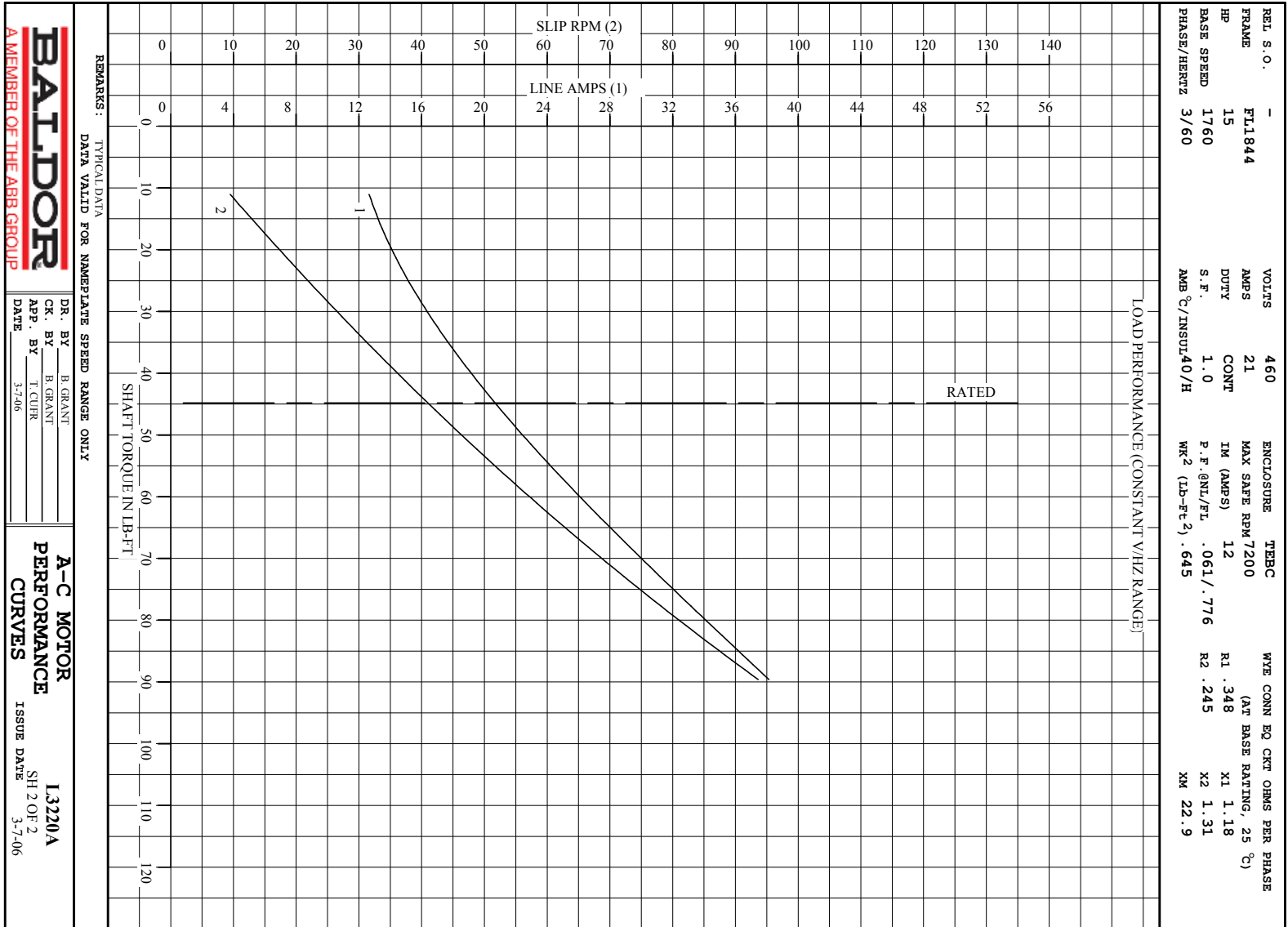

RPM-AC FINNED FRAME VARIABLE SPEED ALTERNATING CURRENT MOTOR
FL1844CZ

ENCLOSURE: TOTALLY ENCLOSED
MOUNTING: FOOT / NEMA 250TC C-FACE
DRIVE METHOD: COUPLED OR BELTED

COOLING: BLOWER COOLED or FAN COOLED
ACCESSORIES: PROVISIONS FOR TACHOMETER MOUNTING ONLY WHEN SPECIFIED

617232-023

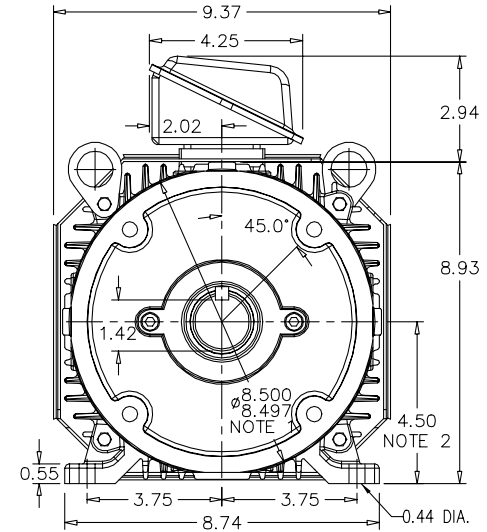
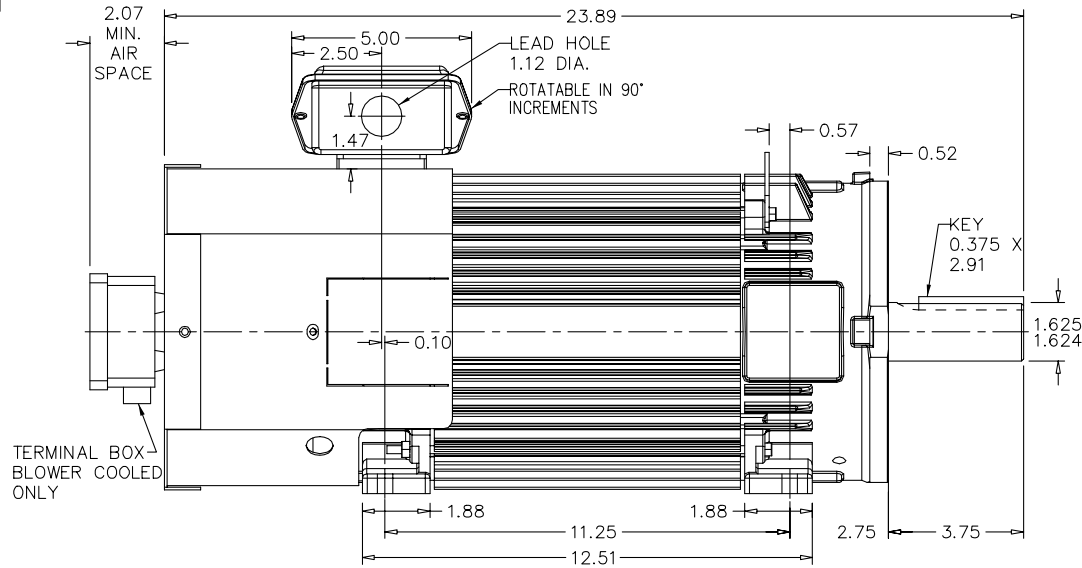

NOTE 1: C-FACE & TACHOMETER MOUNTING
1/2-13 TAP, 1.00 DEEP, ON A 7.25 DIA. BOLT CIRCLE
FACE RUNOUT AND ECCENTRICITY 0.004 MAX. T.I.R.
NOTE 2: SHAFT HEIGHT WILL NOT BE EXCEEDED
SHIMS UP TO 0.03 INCHES IN THICKNESS ARE USUALLY
REQUIRED FOR COUPLED OR GREARED MACHINES

TERMINAL BOX MAY BE LOCATED F1 OR F2 IF SPECIFIED
40 AMP STEEL TERMINAL BOX SHOWN
REFER TO 616779-50 FOR SPECIFIED TERMINAL BOX DIMENSIONS
REFER TO 616779-55 FOR SPECIFIED TACHOMETER DIMENSIONS

MOTOR WEIGHT: 180 LBS. (MAY VARY 15%)
DIMENSIONS ARE IN INCHES SCALE: 1.00

CUSTOMER IS RESPONSIBLE FOR DETERMINING THAT BALDOR'S PRODUCT WILL PERFORM SUITABLY IN THE INTENDED APPLICATION.

REV. DESC: CHANGE FOOT HEIGHT TO C/L TO 4.50	VERSION: 03	TDR: 000000895607
REV. LTR: C	REVISED: 01:42:33 03/05/2015	BY: RGGWT
FILE: \RGG\00003\468		
MTL: -		

BALDOR

DIM SHT RPM AC TEBC / FC FL1844CZ FT/250TC MTG PROV FOR TACH
SH 1 of 1

617232-023

616779-050

INDUSTRIAL ALTERNATING CURRENT MOTORS

RPM AC

STEEL, CAST IRON, MILL AND TERMINAL BOARD CONDUIT BOX DIMENSIONS
 NEMA FRAMES FL210 thru FL280 and IEC FRAMES RDL132 thru RDL180
 NEMA FRAMES FL180 thru FL280 and IEC FRAMES FDL112 thru FDL180

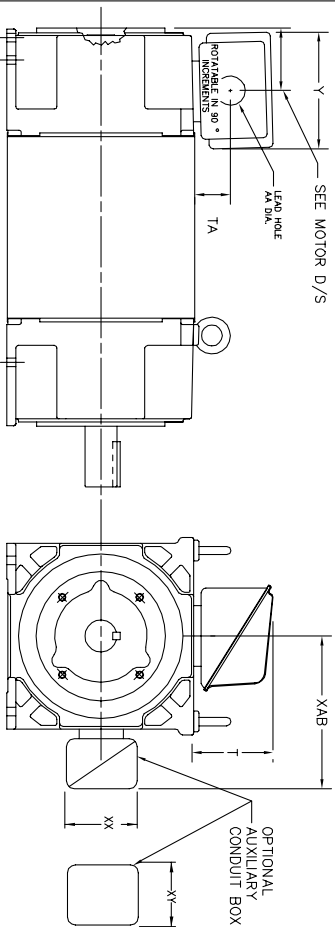

FRAME	TYPE	TERMINAL STRIP	AMPS	C/BOX	Y	TA	T	AA
FL180	STEEL	N	40	706320003A	5.00	1.62	3.00	1.12
FL210	STEEL	N	75	706320005A	6.12	2.38	4.38	1.75/2.00
FL280	STEEL	N	208	706320007A	7.62	2.00	7.00	2.50/3.00
FL180	CAST IRON	Y/N	60	706320004C	5.75	2.38	4.38	1.0 TAP
FL180 & FDL11	MILL	Y	100	706310056A	7.75	2.30	4.40	PG29/PG16

FL210 & RDL210	STEEL	N	61	075452000B	6.34	2.00	4.12	1.75
FL210 & RDL210	STEEL	N	121	075454001AJ	7.69	2.38	5.25	1.94
FL210 & RDL210	STEEL	N	305	706320016A	9.00	4.12	8.44	4.59
FL210 & RDL210	CAST IRON	N	110	075460062B	7.25	2.50	5.25	1.5 TAP
FL210 & RDL13	MILL	Y	100	706310225R	7.75	2.30	4.40	PG29/PG16
FL210 & RDL13	MILL	Y	160	706310226R	9.00	3.06	5.40	PG36/PG16
FL210 & RDL13	MILL	Y	160	706310056B	9.00	3.06	5.40	PG36/PG16

FL250 & RL250	STEEL	N	61	075452000B	6.34	2.00	4.12	1.75
FL250 & RL250	STEEL	N	121	075454001AJ	7.69	2.38	5.25	1.94
FL250 & RL250	STEEL	N	305	706320016A	9.00	4.12	8.44	4.59
FL250 & RL250	CAST IRON	N	110	075460062B	7.25	2.50	5.25	1.5 TAP
FL250 & RL250	CAST IRON	N	210	706320013A	10.50	4.88	9.00	4.0 TAP
FL250 & RL250	CAST IRON	N	510	706320014D	15.00	7.56	12.81	5.0 TAP
FL16 & RDL16	MILL	Y	100	706310056A	7.75	2.30	4.40	PG29/PG16
FL250 & RL250	MILL	Y	160	706310225R	9.00	3.06	5.40	PG36/PG16
FL16 & RDL16	MILL	Y	160	706310056B	9.00	3.06	5.40	PG36/PG16
FL250 & RL250	MILL	Y	400	706310063B	14.39	7.43	12.15	BLANK

FL280 & RL280	STEEL	N	160	706320009A	7.25	3.50	7.06	2.50
FL280 & RL280	STEEL	N	305	706320016A	9.00	4.12	8.44	4.59
FL280 & RL280	STEEL	N	500	702658001C	14.62	7.56	12.70	5.00
FL280 & RL280	CAST IRON	N	140	706320012B	9.25	4.81	8.56	3.0 TAP
FL280 & RL280	CAST IRON	N	210	706320013A	10.50	4.88	9.00	4.0 TAP
FL280 & RL280	CAST IRON	N	510	706320014D	15.00	7.56	12.81	5.0 TAP
FL16 & RDL16	MILL	Y	100	706310056A	7.75	2.30	4.40	PG29/PG16
FL16 & RDL16	MILL	Y	160	706310056B	9.00	3.06	5.40	PG36/PG16
FL280 & RL280	MILL	Y	160	706310056B	9.00	3.06	5.40	PG36/PG16
FL280 & RL280	MILL	Y	400	706310063B	14.39	7.43	12.15	BLANK

FRAME SIZE	XAB	XX	XY	PART NUMBER	FRAME SIZE	XAB	XX	XY	PART NUMBER
FL200/TL180/RL200/ML18	7.38	4.25	4.25	603C007-26-A	FL200/TL180/RL200/ML18	10.88	8.00	8.00	706310-3-B
FL200/TL180/RL200/ML160	8.44	4.25	4.25	603C007-26-A	FL200/TL180/RL200/ML160	11.88	8.00	8.00	706310-3-B
FL280/TL180/RL280/ML180	9.12	4.25	4.25	603C007-26-A	FL280/TL180/RL280/ML180	12.62	8.00	8.00	706310-3-B

- (1) TAP CONDUIT
- (2) TAP PIPE TAP
- (3) CUSTOMER TO PROVIDE HOLE FOR CONDUIT.
- (4) 2" DN -5A or 1" TAP DN -4C

TERMINAL BOX CAN BE KEPT FOR LEAD OUTLET AT TOP SIDES OR BOTTOM TERMINAL BOX CAN BE KEPT FOR LEAD OUTLET AT TOP SIDES OR BOTTOM SIDE WHEN SPECIFIED. DIM LOCATED ON TYP WHEN SPECIFIED.

050-667919

CUSTOMER IS RESPONSIBLE FOR DETERMINING THAT BALDOR'S PRODUCT WILL PERFORM SUITABLY IN THE INTENDED APPLICATION.

REV. DESC:	ADD C/BOX 706310-225 & -226R	TDR:	000001093792
REV. LTR:	E	VERSION:	05
FILE:	RGCV\0003\692	REVISED:	07-27-02 12/18/2018
MTL:	-	BY:	RGCVT

BALDOR - RELIANCE®

DIM SH1 NEMA RL210-RL280 FL180-FL280 IEC RDL132-RDL180

SH 1 of 1

422927-001

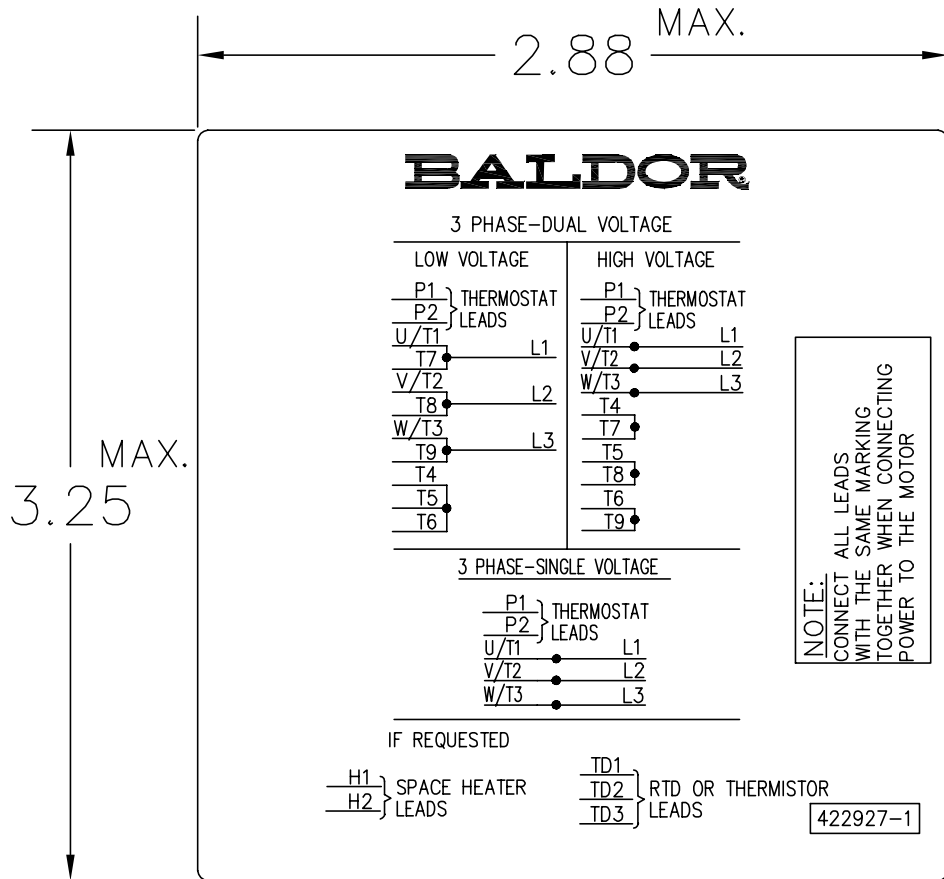

NOTE:
DATA TO BE SIZED
SO THAT IT FITS INTO
MATERIAL DECAL
DIMENSIONS. MAKE
LETTERS & NUMBERS
AS LARGE AS POSSIBLE.

MATERIAL: CERAMATIC DGF-P4
PERMA GRIP ADHESIVE

ALL LETTERS, NUMBERS
AND LINES TO BE BLACK
ON WHITE BACKGROUND.

422927-001

REV. DESC: CHANGE BACKGROUND COLOR FROM GOLD TO WHITE		
REV. LTR: B	VERSION: 02	TDR: 000000788708
FILE: \RGG\00000\203	REVISED: 08:09:29 03/04/2013	
MTL: -	BY: RGGWT	

BALDOR

EXTERNAL CONNECTION LABEL

SH 1 of 1

Marketing maintained PDF of MN406:

<http://www.baldor.com/support/Literature/Load.ashx/MN406?ManNumber=MN406>