

# **UC-8410/8416/8418/8430-LX User's Manual**

---

**Sixth Edition, June 2011**

[www.moxa.com/product](http://www.moxa.com/product)



© 2011 Moxa Inc. All rights reserved.  
Reproduction without permission is prohibited.

# UC-8410/8416/8418/8430 LX

## User's Manual

The software described in this manual is furnished under a license agreement and may be used only in accordance with the terms of that agreement.

### Copyright Notice

Copyright ©2011 Moxa Inc.  
All rights reserved.  
Reproduction without permission is prohibited.

### Trademarks

The MOXA logo is a registered trademark of Moxa Inc.  
All other trademarks or registered marks in this manual belong to their respective manufacturers.

### Disclaimer

Information in this document is subject to change without notice and does not represent a commitment on the part of Moxa.

Moxa provides this document as is, without warranty of any kind, either expressed or implied, including, but not limited to, its particular purpose. Moxa reserves the right to make improvements and/or changes to this manual, or to the products and/or the programs described in this manual, at any time.

Information provided in this manual is intended to be accurate and reliable. However, Moxa assumes no responsibility for its use, or for any infringements on the rights of third parties that may result from its use.

This product might include unintentional technical or typographical errors. Changes are periodically made to the information herein to correct such errors, and these changes are incorporated into new editions of the publication.

### Technical Support Contact Information

[www.moxa.com/support](http://www.moxa.com/support)

#### **Moxa Americas**

Toll-free: 1-888-669-2872  
Tel: +1-714-528-6777  
Fax: +1-714-528-6778

#### **Moxa Europe**

Tel: +49-89-3 70 03 99-0  
Fax: +49-89-3 70 03 99-99

#### **Moxa China (Shanghai office)**

Toll-free: 800-820-5036  
Tel: +86-21-5258-9955  
Fax: +86-10-6872-3958

#### **Moxa Asia-Pacific**

Tel: +886-2-8919-1230  
Fax: +886-2-8919-1231

# Table of Contents

<b>1. Introduction</b>	<b>1-1</b>
Overview	1-2
Software Architecture	1-2
Journaling Flash File System (JFFS2)	1-3
Software Features	1-3
<b>2. Getting Started</b>	<b>2-1</b>
Powering on the UC-8410/8416/8418/8430	2-2
Connecting the UC-8410/8416/8418/8430/8430 to a PC	2-2
Serial Console	2-2
Telnet Console	2-2
SSH Console	2-3
Configuring the Ethernet Interface	2-4
Modifying Network Settings with the Serial Console	2-4
Modifying Network Settings over the Network	2-6
Test Program—Developing Hello.c	2-6
Installing the Tool Chain (Linux)	2-6
Checking the Flash Memory Space	2-7
Compiling Hello.c	2-7
Uploading and Running the “Hello” Program	2-8
<b>3. Managing Embedded Linux</b>	<b>3-1</b>
System Version Information	3-2
Firmware Upgrade	3-2
Upgrading the Firmware	3-2
Loading Factory Defaults	3-4
Enabling and Disabling Daemons	3-5
Setting the Run-Level	3-7
Setting the System Time	3-8
TZ variable	3-8
etc/timezone	3-8
Adjusting the System Time	3-8
Setting the Time Manually	3-8
NTP Client	3-9
Updating the Time Automatically	3-9
Cron—Daemon to Execute Scheduled Commands	3-10
Connecting Peripherals	3-11
USB Mass Storage	3-11
CF Mass Storage	3-11
<b>4. Managing Communication</b>	<b>4-1</b>
Telnet/FTP	4-2
DNS	4-2
Web Service—Apache	4-3
IPTABLES	4-4
NAT	4-8
NAT Example	4-9
Enabling NAT at Bootup	4-9
Dial-up Service—PPP	4-10
PPPoE	4-13
NFS (Network File System) Client	4-15
Setting up the UC-8410/8416/8418/8430/8430 as an NFS Client	4-15
Mail	4-15
SNMP	4-16
OpenVPN	4-17
Package Management—ipkg	4-24
Audio Playing and Recording	4-24
Volume Control	4-24
Playing a WAVE File	4-25
Recording a WAVE file	4-25
<b>5. Programmer's Guide</b>	<b>5-1</b>
Flash Memory Map	5-2
Linux Tool Chain Introduction	5-2
Debugging with GDB	5-3
Device API	5-4
RTC (Real Time Clock)	5-4
Buzzer	5-5
WDT (Watch Dog Timer)	5-5
Digital I/O	5-8
UART	5-13

SRAM .....	5-15
Make File Example .....	5-16
Moxa CAN Programming Guide .....	5-17
Introduction.....	5-17
Programming Guide.....	5-17
Software Lock .....	5-19
Qt-embedded.....	5-20
Compile and Test the QT Program on an X86 Machine.....	5-21
Set up Qt development .....	5-21
Cross-compile the Qt application and run with Dual-display .....	5-21
Upload the binary to target and run it with following command .....	5-22
<b>A. Firmware Upgrade Procedure.....</b>	<b>A-1</b>
<b>B. System Commands.....</b>	<b>B-1</b>
Linux Normal Command Utility Collection.....	B-1
File Manager.....	B-1
Editor .....	B-1
Network.....	B-2
Process .....	B-2
Modules .....	B-2
Other.....	B-2
Special Moxa Utilities .....	B-3

## Introduction

---

Welcome to the Moxa UC-8400 Series of RISC-based communication platforms.

The UC-8410/8416/8418/8430 embedded computer comes with 8 RS-232/422/485 serial ports, 3 Ethernet ports, 4 digital input channels, 4 digital output channels, (12 digital input channels and 12 digital output channels for UC-8418), 8 10/100 Mbps switch ports (UC-8416 only), a CompactFlash socket, and 2 USB 2.0 ports. In addition, the UC-8430 comes with 2 VGA outputs, making it the perfect solution for applications that require HMI for field site monitoring.

The UC-8410/8416/8418/8430 computer uses the Intel XScale IXP435 533 MHz RISC CPU. This powerful computing engine supports several useful communication functions, but will not generate too much heat. The built-in 16 MB NORFlash ROM can be used to store the operating system, and 256 MB SDRAM gives you enough memory to run your application software directly on the UC-8410/8416/8418/8430. Moreover, the 32 MB NAND Flash provides the capacity for data storage.

The UC-8410/8416/8418/8430 computer supports RS-232/422/485 serial ports, digital I/O, and has three LAN ports, making it ideal as a communication platform for industrial applications that require network redundancy.

Pre-installed with the Linux 2.6 platform, the UC-8410/8416/8418/8430 provides an open software operating system for software program development. Software written for a desktop PC can be easily ported to the UC-8410/8416/8418/8430 platform by using a GNU cross compiler, without needing to modify the code. This makes the UC-8410/8416/8418/8430 an optimal solution for your industrial applications with the minimal cost and effort.

In addition to the standard model, a wide temperature version (-40 to 75°C) of the UC-8410/8416/8418/8430 is also available for use in harsh industrial environments.

The following topics are covered in this chapter:

□ **Overview**

□ **Software Architecture**

- Journaling Flash File System (JFFS2)
- Software Features

# Overview

The UC-8410/8416/8418/8430 computer, which features a RISC CPU, RAM memory, serial ports for connecting RS-232/422/485 devices, and 3 10/100 Mbps Ethernet ports, is designed for embedded applications.

The UC-8410/8416/8418/8430 uses an Intel XScale IXP435 533 Mhz RISC CPU. Unlike the x86 CPU, which uses a CISC design, the RISC architecture and modern semiconductor technology provide this computer with a powerful computing engine and communication functions, but without generating a lot of heat. The built-in 16 MB NOR Flash ROM can be used to store the operating system, and 256 MB of SDRAM gives you enough memory to run your application software directly on the UC-8410/8416/8418/8430. Moreover, the 32 MB NAND Flash provides the capacity for data storage. In addition, the network capability provided by the 3 LAN ports built into the RISC CPU combined with the ability to control connected serial devices makes the UC-8410/8416/8418/8430/8430 an ideal communication platform for data acquisition and industrial control applications.

The UC-8410/8416/8418/8430's pre-installed open source Linux operating system can run software written for desktop PCs, provided the software is ported to the computer with a GNU cross compiler. The process is easy, straightforward, and your programmer will not need to modify the source code. The OS, device drivers (e.g., Ethernet, SRAM, watchdog, and Buzzer control) and your own applications, can all be stored in the NOR Flash memory.

# Software Architecture

The Linux operating system that comes pre-installed on the UC-8410/8416/8418/8430/8430 follows the standard Linux architecture, making it easy to run programs that follow the POSIX standard. Program porting is done with the GNU Tool Chain provided by Moxa. In addition to Standard POSIX APIs, device drivers for the buzzer, SRAM and watchdog controls, and UART are also included in the Linux OS.

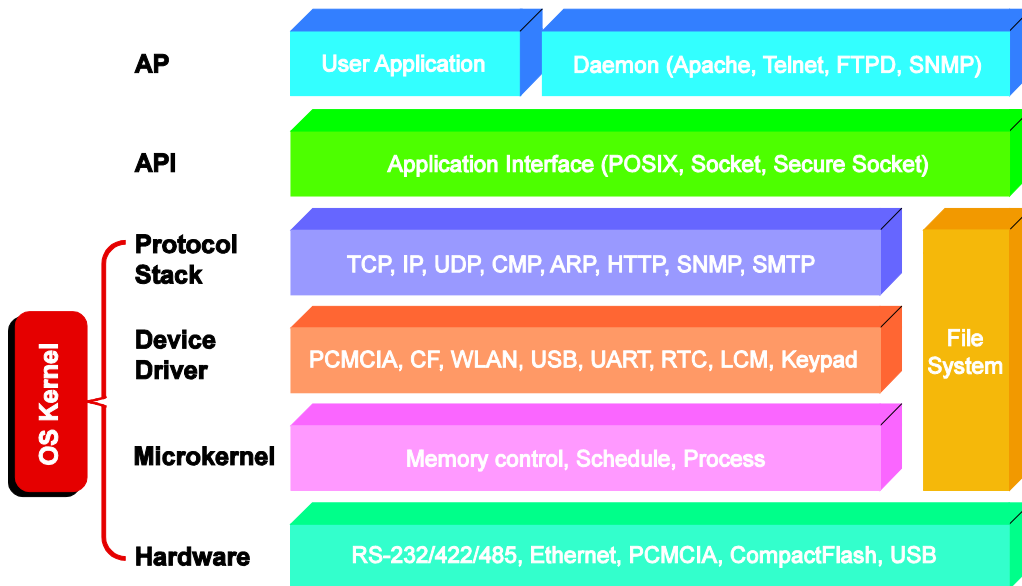

The UC-8410/8416/8418/8430's built-in Flash ROM is divided into **Boot Loader**, **Linux Kernel**, **Root File System**, and **User Root File System** partitions.

In order to prevent user applications from crashing the Root File System, the UC-8410/8416/8418/8430/8430 uses a specially designed **Root File System with Protected Configuration** for emergency use. This **Root File System** comes with serial and Ethernet communication capability for users to load the **Factory Default Image** file. The user directory saves the user's settings and application.

To improve system reliability, the UC-8410/8416/8418/8430/8430 has a built-in mechanism that prevents the system from crashing. When the Linux kernel boots up, the kernel will mount the root file system for read only,

and then enable services and daemons. During this time, the kernel will start searching for system configuration parameters via *rc* or *inittab*.

Normally, the kernel uses the Root File System to boot up the system. The Root File System is protected, and cannot be changed by the user, providing a “safe” zone.

For more information about memory map and programming, refer to Chapter 5, “Programmer’s Guide.”

## Journaling Flash File System (JFFS2)

The User Root File System in the flash memory is formatted with the **Journaling Flash File System (JFFS2)**. The formatting process places a compressed file system in the flash memory, transparent to the user.

The Journaling Flash File System (JFFS2), which was developed by Axis Communications in Sweden, puts a file system directly on the flash, instead of emulating a block device. It is designed for use on flash-ROM chips and recognizes the special write requirements of a flash-ROM chip. JFFS2 implements wear-leveling to extend the life of the flash disk, and stores the flash directory structure in the RAM. A log-structured file system is maintained at all times. The system is always consistent, even if it encounters crashes or improper power-downs, and does not require *fsck* (file system check) on boot-up.

JFFS2 is the newest version of JFFS. It provides improved wear-leveling and garbage-collection performance, improved RAM footprint and response to system-memory pressure, improved concurrency and support for suspending flash erases, marking of bad sectors with continued use of the remaining good sectors (which enhances the write-life of the devices), native data compression inside the file system design, and support for hard links.

The key features of JFFS2 are:

- Targets the Flash ROM directly
- Robustness
- Consistency across power failures
- No integrity scan (fsck) is required at boot time after normal or abnormal shutdown
- Explicit wear leveling
- Transparent compression

Although JFFS2 is a journaling file system, this does not preclude the loss of data. The file system will remain in a consistent state after power failures and will always be mountable. However, if the board is powered down during a write then the incomplete write will be rolled back on the next boot, but writes that have already been completed will not be affected.

**Additional information about JFFS2 is available on the following websites:**

<http://sources.redhat.com/jffs2/jffs2.pdf>

<http://developer.axis.com/software/jffs/>

<http://www.linux-mtd.infradead.org/>

## Software Features

### Linux

**Kernel Version:** 2.6.23

**Protocol Stack:** TCP, UDP, IPv4, SNMP V1, ICMP, ARP, HTTP, CHAP, PAP, SSH 1.0/2.0, SSL, DHCP, NTP, NFS, Telnet, FTP, PPP, PPPoE, OpenVPN

**File System:** JFFS2, NFS, Ext2, Ext3

**System Utilities:** bash, busybox, tinylogin, telnet, ftp, ssh, scp

**telnetd:** telnet Server daemon

**ftpd:** FTP server daemon

**sshd:** secure shell server

**Apache:** web server daemon, supporting PHP and XML

**openvpn:** virtual private network service manager

**pppd:** dial in/out over serial port daemon

**snmpd:** snmpd agent daemon

**openssl:** open SSL

**Application Development Software:** Moxa Linux API device control

**Linux Tool Chain:**

**Firmware v1.X:**

- GCC (V4.2.1): C/C++ PC Cross Compiler
- Glibc (V2.2.5): POSIX standard C Library

**Firmware v2.X:**

- GCC (V4.4.2): C/C++ PC Cross Compiler
- Glibc (V2.10.1): POSIX standard C Library

**Software Encryption Lock:**

BINEncryptor: Encryption tool for binary files (based on patented Moxa technology)



## Getting Started

---

In this chapter, we explain how to connect the UC-8410/8416/8418/8430, turn on the power, and then get started with programming and using other functions.

The following topics are covered in this chapter:

- ❑ **Powering on the**
- ❑ **Connecting the UC-8410/8416/8418/8430/8430 to a PC**
  - Serial Console
  - Telnet Console
  - SSH Console
- ❑ **Configuring the Ethernet Interface**
  - Modifying Network Settings with the Serial Console
  - Modifying Network Settings over the Network
- ❑ **Test Program—Developing Hello.c**
  - Installing the Tool Chain (Linux)
  - Checking the Flash Memory Space
  - Compiling Hello.c
  - Uploading and Running the “Hello” Program

# Powering on the UC-8410/8416/8418/8430

Connect the SG wire to the Shielded Contact located in the upper left corner of the UC-8410/8416/8418/8430, and then power on the computer by connecting it to the power adaptor. It takes about 30 to 60 seconds for the system to boot up. Once the system is ready, the Ready LED will light up.



## ATTENTION

After connecting the UC-8410/8416/8418/8430/8430 to the power supply, it will take about 16 seconds for the operating system to boot up. The green Ready LED will not turn on until the operating system is ready.

## Connecting the UC-8410/8416/8418/8430/8430 to a PC

There are two ways to connect the UC-8410/8416/8418/8430/8430 to a PC: directly through the serial console port, or by Telnet over the network. For the UC-8430, you can connect the display with the display cable. Once you turn on the power, you will be able to access the computer and conduct additional configurations.

### Serial Console

The serial console port gives users a convenient way of connecting to the UC-8410/8416/8418/8430's console utility. This method is particularly useful when using the computer for the first time. The signal is transmitted over a direct serial connection, so you do not need to know either of its 3 IP addresses in order to connect to the UC-8410/8416/8418/8430.

Use the serial console port settings shown below.

Baudrate	115200 bps
Parity	None
Data bits	8
Stop bits	1
Flow Control	None
Terminal	VT100

Once the connection is established, you can start using UC-8410/8416/8418/8430.

### Telnet Console

If you know at least one of the IP addresses and netmasks, you can use Telnet to connect to the UC-8410/8416/8418/8430's console utility. The default IP address and Netmask for each of the ports are given below:

	Default IP Address	Netmask
LAN 1*	192.168.3.127	255.255.255.0
LAN 2	192.168.4.127	255.255.255.0
LAN 3	192.168.5.127	255.255.255.0

\*Please note that the LAN1 of the UC-8430 uses DHCP for both IP Address and Netmask.

Use a cross-over Ethernet cable to connect directly from your PC to the UC-8410/8416/8418/8430. You should first modify your PC's IP address and netmask so that your PC is on the same subnet as one of the UC-8410/8416/8418/8430's LAN ports. For example, if you connect to LAN 1, you can set your PC's IP address to 192.168.3.126 and netmask to 255.255.255.0. If you connect to LAN 2, you can set your PC's IP address to 192.168.4.126 and netmask to 255.255.255.0.

To connect to a hub or switch connected to your local LAN, use a straight-through Ethernet cable. The default IP addresses and netmasks are shown above. To log in, type the Login name and password as requested. The default values are both root:

**Login:** root  
**Password:** root



You can proceed with configuring network settings of the target computer when you reach the bash command shell. Configuration instructions are given in the next section.



**ATTENTION**

**Serial Console Reminder**  
Remember to choose VT100 as the terminal type. Use cable CBL-4PINDB9F-100, which comes with the UC-8410/8416/8418/8430, to connect to the serial console port.

**Telnet Reminder**  
When connecting to the UC-8410/8416/8418/8430/8430 over a LAN, you must configure your PC's Ethernet IP address to be on the same subnet as the UC-8410/8416/8418/8430/8430 you wish to connect to. If you do not get connected on the first try, re-check the IP settings, and then unplug and re-plug the UC-8410/8416/8418/8430's power cord.

## SSH Console

The UC-8410/8416/8418/8430/8430 supports an SSH console to provide users with better security options.

### Windows Users

Click on the link <http://www.chiark.greenend.org.uk/~sgtatham/putty/download.html> to download PuTTY (free software) to set up an SSH console for the UC-8410/8416/8418/8430/8430 in a Windows environment. The following figure shows a simple example of the configuration that is required.

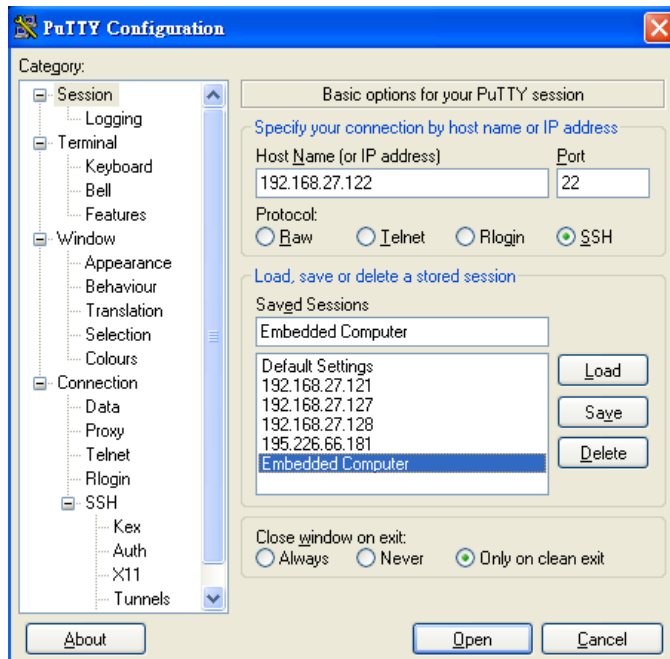

## Linux Users

From a Linux machine, use the “ssh” command to access the UC-8410/8416/8418/8430’s Console utility via SSH.

```
#ssh 192.168.3.127
```

Select yes to complete the connection.

```
[root@bee_notebook root]# ssh 192.168.3.127
The authenticity of host '192.168.3.127 (192.168.3.127)' can't be established.
RSA key fingerprint is 8b:ee:ff:84:41:25:fc:cd:2a:f2:92:8f:cb:1f:6b:2f.
Are you sure you want to continue connection (yes/no)? yes_
```

**NOTE** SSH provides better security compared to Telnet for accessing the UC-8410/8416/8418/8430’s console utility over the network.

## Configuring the Ethernet Interface

The network settings of the UC-8410/8416/8418/8430/8430 can be modified with the serial console, or online over the network.

## Modifying Network Settings with the Serial Console

In this section, we use the serial console to configure network settings of the target computer.

Follow the instructions given in a previous section to access the console utility of the target computer via the serial console port, and then type **#cd /etc/network** to change directory.

```
root@Moxa:~# cd /etc/network/
root@Moxa:/etc/network/#
```

Type **#vi interfaces** to edit the network configuration file with vi editor. You can configure the UC-8410/8416/8418/8430’s Ethernet ports for **static** or **dynamic** (DHCP) IP addresses.

**Static IP addresses:**

As shown below, 3 network addresses need to be modified: **address**, **network**, **netmask**, and **broadcast**. The default IP addresses are 192.168.3.127 for LAN1, 192.168.4.127 for LAN2, and 192.168.5.127 for LAN3, with default netmasks of 255.255.255.0.

```
# We always want the loopback interface.

auto eth0 eth1 eth2 lo
iface lo inet loopback

# embedded ethernet LAN1
iface eth0 inet static
    address 192.168.3.127
    network 192.168.3.0
    netmask 255.255.255.0
    broadcast 192.168.3.255

# embedded ethernet LAN2
iface eth1 inet static
    address 192.168.4.127
    network 192.168.4.0
    netmask 255.255.255.0
    broadcast 192.168.4.255

# embedded ethernet LAN3
iface eth2 inet static
    address 192.168.5.127
    network 192.168.5.0
```

**Dynamic IP Addresses:**

By default, the UC-8410/8416/8418/8430 is configured for "static" IP addresses. To configure LAN ports to request an IP address dynamically, replace **static** with **dhcp** and then delete the address, network, netmask, and broadcast lines.

Default Setting for LAN1	Dynamic Setting using DHCP
<pre>iface eth0 inet static     address 192.168.3.127     network: 192.168.3.0     netmask 255.255.255.0     broadcast 192.168.3.255</pre>	<pre>iface eth0 inet dhcp</pre>

\*Please note that the default value for LAN1 of the UC-8430 is DHCP.

```
Auto eth0 eth1 lo
iface lo inet loopback

iface eth0 inet dhcp

iface eth1 inet dhcp
```

After the boot settings of the LAN interface have been modified, issue the following command to activate the LAN settings immediately:

```
#!/etc/init.d/networking restart
```

**ATTENTION**

After changing the IP settings, use the **networking restart** command to activate the new IP address.

## Modifying Network Settings over the Network

IP settings can be activated over the network, but the new settings will not be saved to the flash ROM without modifying the file `/etc/network/interfaces`.

For example, type the command `#ifconfig eth0 192.168.1.1` to change the IP address of LAN1 to 192.168.1.1.

```
root@Moxa:# ifconfig eth0 192.168.1.1
root@Moxa:/etc/network/#
```

## Test Program—Developing Hello.c

1. Connect the UC-8410/8416/8418/8430/8430 to a Linux PC.
2. Install the Tool Chain (GNU Cross Compiler & glibc).
3. Set the cross compiler and glibc environment variables.
4. Code and compile the program.
5. Download the program to the UC-8410/8416/8418/8430/8430 via FTP or NFS.
6. Debug the program
  - If bugs are found, return to Step 4.
  - If no bugs are found, continue with Step 7
7. Back up the user directory (distribute the program to additional UC-8410/8416/8418/8430/8430 units if needed).

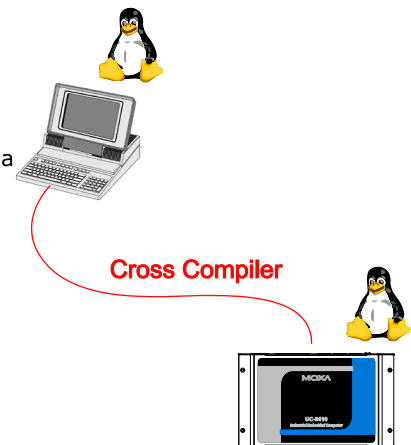

## Installing the Tool Chain (Linux)

The PC must have the Linux operating system pre-installed before installing the UC-8410/8416/8418/8430/8430 GNU Tool Chain. Redhat 7.3/8.0, Fedora core, and compatible versions are recommended. The Tool Chain requires about 600 MB of hard disk space on your PC. The UC-8410/8416/8418/8430/8430 Tool Chain software is located on the UC-8410/8416/8418/8430/8430 CD. To install the Tool Chain, insert the CD into your PC and then issue the following commands:

### With v1.x firmware:

```
#mount /dev/cdrom /mnt/cdrom#/mnt/cdrom/tool-chain/Linux/arm-linux_2.3.sh
```

### With v2.x firmware:

```
#mount /dev/cdrom
/mnt/cdrom#/mnt/cdrom/tool-chain/Linux/arm-linux_3.0_Build_YMMDDHH.sh
```

The Tool Chain will be installed automatically on your Linux PC within a few minutes. Before compiling the program, be sure to set the following path first, since the Tool Chain files, including the compiler, link, library, and include files, are located in this directory.

### With v1.x firmware and arm-linux 2.x.sh:

```
PATH=/usr/local/arm-linux/bin:$PATH
```

### With v2.x firmware and arm-linux 2.x.sh and arm-linux\_3.0\_Build\_YMMDDHH.sh:

```
PATH=/usr/local/arm-linux-4.4.2/bin:$PATH
```

Setting the path allows you to run the compiler from any directory.

**ATTENTION**

If you have an older version of Linux Tool Chain on your Moxa embedded computer (such as the W300 Series, IA240/241, and UC-7112-LX Plus) and would like to install the new Linux Tool Chain for the UC-8410/8416/8418/8430, the old Linux Tool Chain files will be immediately overwritten, and the programs compiled by this new Tool Chain may not work on your old models. We strongly suggest you rename the directory of the old Linux Tool Chain before installing the new one if you would like to use the old Linux Tool Chain for other embedded computers.

## Checking the Flash Memory Space

The UC-8410/8416/8418/8430/8430 uses a specially designed root file system. Only /tmp, /etc, /home, /usr/local/bin, /usr/local/sbin, /usr/local/libexec, and /usr/local/lib directories are writable. Others are read-only. The writable directories are mounted on /dev/mtdblock4. If the /dev/mtdblock4 is full, you will not be able to save data to the Flash ROM. Use the following command to calculate the amount of "Available" flash memory:

```
>df -h
```

```
root@Moxa:/# df -h
Filesystem      Size      Used Available Use% Mounted on
rootfs          13.4M     9.8M      3.5M   74% /
/dev/root       13.4M     9.8M      3.5M   74% /
/dev/ram15      1.7M     19.0k     1.6M    1% /dev
/dev/ram0       499.0k    18.0k    456.0k   4% /var
/dev/mtdblock4 32.0M     1.9M     30.1M   6% /tmp
/dev/mtdblock4 32.0M     1.9M     30.1M   6% /home
/dev/mtdblock4 32.0M     1.9M     30.1M   6% /etc
tmpfs           252.5M      0     252.5M   0% /dev/shm
/dev/sdb1       483.4M    57.9M    425.5M  12% /var/sdb
root@Moxa:/#
```

If there isn't enough "Available" space for your application, you will need to delete some existing files. To do this, connect your PC to the UC-8410/8416/8418/8430/8430 with the console cable, and then use the console utility to delete the files from the UC-8410/8416/8418/8430's flash memory.

## Compiling Hello.c

The CD contains several sample programs. Here we use **Hello.c** to show you how to compile and run your applications. Type the following commands from your PC to copy the files used for this example from the CD to your computer's hard drive:

```
# cd /tmp/
# mkdir example
# cp -r /mnt/cdrom/example/* /tmp/example
```

To compile the program, go to the **hello** subdirectory and issue the following commands:

```
#cd example/hello
#make
```

You should receive the following response:

```
[root@localhost hello]# make
xscale-linux-gcc -o hello-release hello.c
xscale-linux-strip -s hello-release
xscale-linux-gcc -ggdb -o hello-debug hello.c
[root@localhost hello]# _
```

Next, execute **hello.exe** to generate **hello-release** and **hello-debug**, which are described below:

**hello-release**—an IXP platform execution file (created specifically to run on the UC-8410/8416/8418/8430)

**hello-debug**—an IXP platform GDB debug server execution file (see Chapter 5 for details about the GDB debug tool).



### ATTENTION

Be sure to type the **#make** command from within the **/tmp/example/hello** directory, since the UC-8410/8416/8418/8430's tool chain puts a specially designed **Makefile** in that directory. This special Makefile uses the `xscale-linux-gcc` compiler to compile the `hello.c` source code for the Xscale environment. If you type the **#make** command from any other directory, Linux will use the x86 compiler (for example, `cc` or `gcc`). Refer to Chapter 5 to see a Make file example.

## Uploading and Running the “Hello” Program

Use the following command to upload **hello-release** to the UC-8410/8416/8418/8430/8430 via FTP.

From the PC, type:

```
#ftp 192.168.3.127
```

Use the `bin` command to set the transfer mode to binary mode, and then `put` command to initiate the file transfer:

```
ftp> cd /home
ftp> bin
ftp> put hello-release
```

From the UC-8410/8416/8418/8430, type:

```
# chmod +x /home/hello-release
# ./home/hello-release
```

The word **Hello** will be printed on the screen.

```
root@Moxa:~# ./home/hello-release
Hello
```



# Managing Embedded Linux

---

This chapter includes information about version control, deployment, updates, and peripherals.

The following topics are covered in this chapter:

- ❑ **System Version Information**
- ❑ **Firmware Upgrade**
  - Upgrading the Firmware
  - Loading Factory Defaults
- ❑ **Enabling and Disabling Daemons**
- ❑ **Setting the Run-Level**
- ❑ **Setting the System Time**
  - TZ variable
  - /etc/timezone
- ❑ **Adjusting the System Time**
  - Setting the Time Manually
  - NTP Client
  - Updating the Time Automatically
- ❑ **Cron—Daemon to Execute Scheduled Commands**
- ❑ **Connecting Peripherals**
  - USB Mass Storage
  - CF Mass Storage

# System Version Information

To determine the hardware capability of your UC-8410/8416/8418/8430/8430 and what kind of software functions are supported, check which version of the firmware your UC-8410/8416/8418/8430/8430 is running. Contact Moxa to determine the hardware version. You will need the **Production S/N** (Serial number), which is located on the UC-8410/8416/8418/8430's bottom label.

To check the kernel version, type:

```
#kversion
```

```
192.168.3.127 - PuTTY
root@Moxa:~# kversion
UC-8410/8416/8418/8430 version 1.0
root@Moxa:~#
root@Moxa:/# kversion -a
UC-8410/8416/8418/8430 version 1.0 Build 08091716
root@Moxa:~#
```

## Firmware Upgrade

### Upgrading the Firmware

The UC-8410/8416/8418/8430's kernel, and root file system are combined into one firmware file, which can be downloaded from Moxa's website ([www.moxa.com](http://www.moxa.com)). The name of the file has the form **FWR\_uc8400\_Va.b.c\_Build\_YYMMDDHH.hfm**, with "a.b.c" indicating the firmware version and **YYMMDDHH** indicating the build date. To upgrade the firmware, download the firmware file to a PC, and then transfer the file to the UC-8410/8416/8418/8430/8430 unit via a serial console or Telnet console connection.



#### ATTENTION

##### Upgrading the firmware will erase all data on the Flash ROM

If you are using the **ramdisk** to store code for your applications, beware that updating the firmware will erase all of the data on the Flash ROM. You should back up your application files and data before updating the firmware.

Since different Flash disks have different sizes, it's a good idea to check the size of your Flash disk before upgrading the firmware, or before using the disk to store your application and data files. Use the **#df -h** command to list the size of each memory block, and how much free space is available in each block.

```
192.168.3.127 - PuTTY
root@Moxa:/# df -h
Filesystem      Size      Used Available Use% Mounted on
rootfs          13.4M     9.8M      3.5M   74% /
/dev/root       13.4M     9.8M      3.5M   74% /
/dev/ram15      1.7M      19.0k     1.6M    1% /dev
/dev/ram0       499.0k    18.0k    456.0k   4% /var
/dev/mtdblock4 32.0M     1.9M     30.1M    6% /tmp
/dev/mtdblock4 32.0M     1.9M     30.1M    6% /home
/dev/mtdblock4 32.0M     1.9M     30.1M    6% /etc
tmpfs           252.5M      0    252.5M   0% /dev/shm
/dev/sdb1      483.4M    57.9M    425.5M  12% /var/sdb
root@Moxa:/#
```

```

root@Moxa:/# upramdisk
root@Moxa:/# df -h
Filesystem                Size      Used Available Use% Mounted on
/dev/mtdblock2            14.0M     11.2M      2.8M  80% /
/dev/ram15                 1.7M       18.0k      1.6M   1% /dev
/dev/ram0                  499.0k     34.0k     440.0k   7% /var
/dev/mtdblock3            15.8M      2.6M     13.1M  17% /tmp
/dev/mtdblock3            15.8M      2.6M     13.1M  17% /home
/dev/mtdblock3            15.8M      2.6M     13.1M  17% /etc
/dev/ram1                  38.7M     13.0k     36.7M   0% /mnt/ramdisk
root@Moxa:/# cd /mnt/ramdisk/
root@Moxa:/mnt/ramdisk#

```

The following instructions give the steps required to save the firmware file to the UC-8410/8416/8418/8430's RAM disk, and then upgrade the firmware.

1. Type the following commands to enable the RAM disk:

```

#upramdisk
#cd /mnt/ramdisk

```

2. Type the following commands to use the UC-8410/8416/8418/8430's built-in FTP client to transfer the firmware file (**FWR\_uc8400\_Va.b.c\_Build\_YMMDDHH.hfm**) from the PC to the UC-8410/8416/8418/8430:

```

/mnt/ramdisk> ftp <destination PC's IP>
Login Name: xxxx
Login Password: xxxx
ftp> bin
ftp> get FWR_uc8400_Va.b.c_Build_YMMDDHH.hfm

```

```

192.168.3.127 - PuTTY
root@Moxa:/mnt/ramdisk# ftp 192.168.3.193
Connected to 192.168.3.193 (192.168.3.193).
220 TYPSoft FTP Server 1.10 ready...
Name (192.168.3.193:root): root
331 Password required for root.
Password:
230 User root logged in.
Remote system type is UNIX.
Using binary mode to transfer files.
ftp> cd newsw
250 CWD command successful. "/C:/ftproot/newsw/" is current directory.
ftp> bin
200 Type set to I.
ftp> ls
200 Port command successful.
150 Opening data connection for directory list.
drw-rw-rw-  1 ftp ftp           0 Nov 30 10:03 .
drw-rw-rw-  1 ftp ftp           0 Nov 30 10:03 ..
-rw-rw-rw-  1 ftp ftp    12904012 Nov 29 10:24
FWR_uc8400_Va.b.c_Build_YMMDDHH.hfm
226 Transfer complete.
ftp> get FWR_uc8400_Va.b.c_Build_YMMDDHH.hfm
local: FWR_uc8400_Va.b.c_Build_YMMDDHH.hfm remote:
FWR_uc8400_Va.b.c_Build_YMMDDHH.hfm
200 Port command successful.

```

```

150 Opening data connection for FWR_uc8400_Va.b.c_Build_YMMDDHH.hfm
226 Transfer complete.
12904012 bytes received in 2.17 secs (5925.8 kB/s)
ftp>

```

3. Next, use the **upgrahfm** command to upgrade the kernel and root file system:

```
#upgrahfm FWR_uc8400_Va.b.c_Build_YMMDDHH.hfm
```

```

192.168.3.127 - PuTTY
root@Moxa:/mnt/ramdisk# upgrahfm FWR_uc8400_Va.b.c_Build_YMMDDHH.hfm
Moxa UC-8400 Upgrade firmware utility version 1.0.
To check source firmware file context.
The source firmware file conext is OK.
This step will upgrade firmware. All the data on flash will be destroyed.
Do you want to continue? (Y/N) :
Now upgrade the file [redboot].
Format MTD device [/dev/mtd0] ...
MTD device [/dev/mtd0] erase 128 Kibyte @ 60000 -- 100% complete.
Wait to write file ...
Completed 100%
Now upgrade the file [kernel].
Format MTD device [/dev/mtd1] ...
MTD device [/dev/mtd1] erase 128 Kibyte @ 1a0000 -- 100% complete.
Wait to write file ...
Completed 100%
Now upgrade the file [root-file-system].
Format MTD device [/dev/mtd2] ...
MTD device [/dev/mtd2] erase 128 Kibyte @ e00000 -- 100% complete.
Wait to write file ...
Completed 100%
Now upgrade the file [directory].
Format MTD device [/dev/mtd5] ...
MTD device [/dev/mtd5] erase 128 Kibyte @ 20000 -- 100% complete.
Wait to write file ...
Completed 100%
Now upgrade the new configuration file.
Upgrade the firmware is OK. Rebooting

```

## Loading Factory Defaults

Press the reset button for more than 5 seconds to force the system to load the factory default settings. All files in the `/home`, `/etc`, `/usr/local/bin`, `/usr/local/sbin`, `/usr/local/lib`, `/usr/local/libexec`, and `/tmp` directories will be deleted. While pressing the reset button, during the first 5 seconds the ready-light will blink once each second. If you continue pressing the button after 5 seconds have passed, the ready-light will turn off, indicating that the factory defaults have been loaded.

**ATTENTION****Reset-to-default will erase all data stored in /dev/mtdblock4**

If you have stored data in the writable partition, you will need to back up these files before resetting the system to default. On the UC-8410/8416/8418/8430, the directories /tmp, /etc, /usr/local/bin, /usr/local/sbin, /usr/local/lib, /usr/local/libexec, and /home are mounted on /dev/mtdblock4. This means that all of the data stored in these directories will be destroyed after resetting to default.

## Enabling and Disabling Daemons

The following daemons are enabled when the UC-8410/8416/8418/8430/8430 boots up for the first time.

- **snmpd** SNMP Agent daemon
- **telnetd** Telnet Server / Client daemon
- **inetd** Internet Daemons
- **ftpd** FTP Server / Client daemon
- **sshd** Secure Shell Server daemon
- **httpd** Apache WWW Server daemon

1. Type the command "ps" to list all processes currently running.

```

192.168.3.127 - PuTTY
root@Moxa:~# cd /etc
root@Moxa:/etc# ps
  PID  USER      VSZ STAT COMMAND
    1  root      1316 S   init [3]
    2  root         0 SW<  [kthreadd]
    3  root         0 SW<  [ksoftirqd/0]
    4  root         0 SW<  [events/0]
    5  root         0 SW<  [khelper]
   30  root         0 SW<  [kblockd/0]
   33  root         0 SW<  [kseriod]
   52  root         0 SW   [pdflush]
   53  root         0 SW   [pdflush]
   54  root         0 SW<  [kswapd0]
   55  root         0 SW<  [aio/0]
  613  root         0 SW<  [mtdblockd]
  652  root         0 SW<  [ixp400_eth time]
  655  root         0 SW<  [ixp400_eth time]
  657  root         0 DW<  [EthMac Recovery]
  667  root         0 SW<  [rpciod/0]
  728  root         0 SW<  [khubd]
  773  root         0 SW<  [scsi_eh_0]
  774  root         0 SW<  [usb-storage]
  788  root         0 SWN  [jffs2_gcd_mtd4]
  814  root         0 SW   [ixp400_eth0]
  820  root         0 SW   [ixp400_eth1]
  834  root      1360 S   /bin/inetd
  858  root     12536 S   /usr/bin/httpd -k start -d /etc/apache
  861  bin       1300 S   /bin/portmap
  867  root      2412 S   /bin/sh --login
  872  root      1360 S   /bin/snmpd -c public
  878  root     3508 S   /bin/sshd -f /etc/ssh/sshd_config

```

```

881 root      1292 S    /bin/reportip
883 nobody   12560 S   /usr/bin/httpd -k start -d /etc/apache
884 nobody   12560 S   /usr/bin/httpd -k start -d /etc/apache
885 nobody   12560 S   /usr/bin/httpd -k start -d /etc/apache
886 nobody   12560 S   /usr/bin/httpd -k start -d /etc/apache
887 nobody   12560 S   /usr/bin/httpd -k start -d /etc/apache

```

- To run a private daemon, edit the file `rc.local`, as follows:

```

#cd /etc/rc.d
#vi rc.local

```

```

192.168.3.127 - PuTTY
root@Moxa:~# cd /etc/rc.d
root@Moxa:/etc/rc.d# vi rc.local

```

- Next, use `vi` editor to edit your application program. We use the sample program `tcps2-release`, and set it to run in the background.

```

192.168.3.127 - PuTTY
# !/bin/sh
# Add you want to run daemon
/root/tcps2-release &

```

- The following daemons will be enabled after you reboot the system.

```

192.168.3.127 - PuTTY
root@Moxa:~# ps -ef
PID  USER     VSZ  STAT  COMMAND
  1  root      1316 S    init [3]
  2  root         0 SW<  [kthreadd]
  3  root         0 SW<  [ksoftirqd/0]
  4  root         0 SW<  [events/0]
  5  root         0 SW<  [khelper]
 30  root         0 SW<  [kblockd/0]
 33  root         0 SW<  [kseriod]
 52  root         0 SW   [pdflush]
 53  root         0 SW   [pdflush]
 54  root         0 SW<  [kswapd0]
 55  root         0 SW   [aio/0]
613  root         0 SW   [mtdblockd]
652  root         0 SW   [ixp400_eth time]
655  root         0 SW   [ixp400_eth time]
657  root         0 DW   [Ethmac Recovery]
666  root         0 SW   [rpciod/0]
727  root         0 SW<  [khubd]
772  root         0 SW<  [scsi_eh_0]
773  root         0 SW<  [usb-storage]
788  root         0 SWN< [jffs2_gcd_mtd4]
809  root         0 SW   [ixp400_eth0]
815  root         0 SW   [ixp400_eth1]

```

```

829 root      1360 S    /bin/inetd
832 bin       1300 S    /bin/portmap
838 root     2428 S    /bin/sh --login
843 root      1360 S    /bin/snmpd -c public
867 root     3508 S    /bin/sshd -f/etc/ssh/sshd_config
873 root     7284 S    /usr/bin/httpd -k start -d/etc/apache
876 root     1292 S    /bin/reportip
878 nobody   7308 S    /usr/bin/httpd -k start -d/etc/apache
879 nobody   7308 S    /usr/bin/httpd -k start -d/etc/apache
880 nobody   7308 S    /usr/bin/httpd -k start -d/etc/apache
881 nobody   7308 S    /usr/bin/httpd -k start -d/etc/apache
882 nobody   7380 S    /usr/bin/httpd -k start -d/etc/apache
883 root     1264 S    /root/tcps2-release
896 root     2156 R    ps

root@Moxa:~#

```

## Setting the Run-Level

In this section, we outline the steps you should take to set the Linux run-level and execute requests. Use the following command to enable or disable settings:

```

192.168.3.127 - PuTTY
root@Moxa:/etc/rc.d/rc3.d# ls
S20snmpd      S55ssh        S99showreadyled
S25nfs-server S99rmnologin
root@Moxa:/etc/rc.d/rc3.d#

```

```
#cd /etc/rc.d/init.d
```

Edit a shell script to execute **/root/tcps2-release** and save to **tcps2** as an example.

```
#cd /etc/rc.d/rc3.d
```

```
#ln -s /etc/rc.d/init.d/tcps2 S60tcps2
```

SxxRUNFILE stands for

S: start the run file while linux boots up.

xx: a number between 00-99. Smaller numbers have a higher priority.

RUNFILE: the file name.

```

192.168.3.127 - PuTTY
root@Moxa:/etc/rc.d/rc3.d# ls
S20snmpd      S55ssh        S99showreadyled
S25nfs-server S99rmnologin
root@Moxa:/etc/rc.d/rc3.d# ln -s /root/tcps2-release S60tcps2
root@Moxa:/etc/rc.d/rc3.d# ls
S20snmpd      S55ssh        S99showreadyled
S25nfs-server S99rmnologin  S60tcps2
root@Moxa:/etc/rc.d/rc3.d#

```

KxxRUNFILE stands for

K: start the run file while Linux shuts down or halts.

xx: a number between 00-99. Smaller numbers have a higher priority.

RUNFILE: the file name.

To remove the daemon, use the following command to remove the run file from `/etc/rc.d/rc3.d`:

```
#rm -f /etc/rc.d/rc3.d/S60tcps2
```

## Setting the System Time

There are two ways to support the timezone configuration on a Moxa embedded computer. One is using the TZ variable. The other is using `/etc/localtime`.

### TZ variable

If you would like to use TZ variable, link to the following URL for all configurations and settings.

<http://www.mksoftware.com/docs/man5/timezone.5.asp>

### `/etc/timezone`

The local timezone is stored in `/etc/localtime` and is used by GNU Library for C (glibc) if the TZ environment variable is not set. This file is either a copy of `/usr/share/zoneinfo/` tree or a symbolic link to it.

The UC-8410/8416/8418/8430/8430 does not provide `/usr/share/zoneinfo/` files, so you need to copy a time zone information file to the UC-8410/8416/8418/8430/8430 and write over the original local time file.

1. The `/usr/share/zoneinfo` folder on a PC that is running standard Linux contains several time zone information files.
2. Copy the time zone file that you want to use to the UC-8410/8416/8418/8430/8430 to overwrite the original `/etc/localtime` file.
3. Type a date to check if the new time zone appears.

## Adjusting the System Time

### Setting the Time Manually

The UC-8410/8416/8418/8430/8430 has two time settings. One is the system time, and the other is the RTC (Real Time Clock) time kept by the UC-8410/8416/8418/8430's hardware. Use the `#date` command to query the current system time or set a new system time. Use `#hwclock` to query the current RTC time or set a new RTC time.

Use the following command to query the system time:

```
#date
```

Use the following command to query the RTC time:

```
#hwclock
```

Use the following command to set the system time:

```
#date MMDDhhmmYYYY
```

MM = Month

DD = Date

hhmm = hour and minute

YYYY = Year

Use the following command to set the RTC time:

```
#hwclock -w
```

Write current system time to RTC

The following figure illustrates how to update the system time and set the RTC time.



```

192.168.3.127 - PuTTY
root@Moxa:~# date
Fri Jun 23 23:30:31 CST 2000
root@Moxa:~# hwclock
Fri Jun 23 23:30:35 2000 -0.557748 seconds
root@Moxa:~# date 070910002006
Sun Jul 9 10:00:00 CST 2006
root@Moxa:~# hwclock -w
root@Moxa:~# date ; hwclock
Sun Jul 9 10:01:07 CST 2006
Sun Jul 9 10:01:08 2006 -0.933547 seconds
root@Moxa:~#

```

## NTP Client

The UC-8410/8416/8418/8430/8430 has a built-in NTP (Network Time Protocol) client that is used to initialize a time request to a remote NTP server. Use **#ntpdate <NTP server>** to update the system time.

```
#ntpdate time.stdtime.gov.tw
```

```
#hwclock -w
```

Visit <http://www.ntp.org> for more information about NTP and NTP server addresses.

```

10.120.53.100 - PuTTY
root@Moxa:~# date ; hwclock
Sat Jan 1 00:00:36 CST 2000
Sat Jan 1 00:00:37 2000 -0.772941 seconds
root@Moxa:~# ntpdate time.stdtime.gov.tw
 9 Dec 10:58:53 ntpdate[207]: step time server 220.130.158.52 offset 155905087.9
84256 sec
root@Moxa:~# hwclock -w
root@Moxa:~# date ; hwclock
Thu Dec 9 10:59:11 CST 2004
Thu Dec 9 10:59:12 2004 -0.844076 seconds
root@Moxa:~#

```



### ATTENTION

Before using the NTP client utility, check your IP and DNS settings to make sure that an Internet connection is available. Refer to Chapter 2 for instructions on how to configure the Ethernet interface, and see Chapter 4 for DNS setting information.

## Updating the Time Automatically

In this subsection, we show how to use a shell script to update the time automatically.

### Example shell script to update the system time periodically

```

#!/bin/sh
ntpdate time.nist.gov
# You can use the time server's ip address or domain
# name directly. If you use domain name, you must
# enable the domain client on the system by updating

```

```
# /etc/resolv.conf file.
hwclock -w
sleep 100      # Updates every 100 seconds. The min. time is 100 seconds. Change 100
               # to a larger number to update RTC less often.
```

Save the shell script using any file name. E.g., **fixtime**

### **How to run the shell script automatically when the kernel boots up**

Copy the example shell script **fixtime** to directory **/etc/init.d**, and then use

**chmod 755 fixtime** to change the shell script mode. Next, use vi editor to edit the file **/etc/inittab**. Add the following line to the bottom of the file:

```
ntp : 2345 : respawn : /etc/init.d/fixtime
```

Use the command **#init q** to re-init the kernel.

## Cron—Daemon to Execute Scheduled Commands

Start Cron from the directory **/etc/rc.d/rc.local**. It will return immediately, so you do not need to start it with an ampersand (&) to run in the background.

The Cron daemon will search **/etc/cron.d/crontab** for crontab files, which are named after accounts in **/etc/passwd**.

Cron wakes up every minute, and checks each command to see if it should be run in the current minute.

Modify the file **/etc/cron.d/crontab** to set up your scheduled applications. Crontab files have the following format:

mm	h	dom	mon	dow	user	command
min	hour	date	month	week	user	command
0-59	0-23	1-31	1-12	0-6 (0 is Sunday)		

The following example demonstrates how to use Cron.

The following steps show how to use cron to update the system time and RTC time every day at 8:00.

#### **STEP1: Write a shell script named `fixtime.sh` and save it to `/home/`.**

```
#!/bin/sh
ntpdate time.nist.gov
hwclock -w
exit 0
```

#### **STEP2: Change mode of `fixtime.sh`**

```
#chmod 755 fixtime.sh
```

#### **STEP3: Modify `/etc/cron.d/crontab` file to run `fixtime.sh` at 8:00 every day.**

Add the following line to the end of crontab:

```
* 8 * * * root /home/fixtime.sh
```

#### **STEP4: Enable the cron daemon manually.**

```
#!/etc/init.d/cron start
```

#### **STEP5: Enable cron when the system boots up.**

Add the following line in the file **/etc/init.d/rc.local**

```
#!/etc/init.d/cron start
```

# Connecting Peripherals

## USB Mass Storage

The UC-8410/8416/8418/8430/8430 supports PNP (plug-n-play), and hot pluggability for connecting USB mass storage devices. The UC-8410/8416/8418/8430/8430 has a built-in auto mount utility that eases the mount procedure. The connected USB mass storage device will be mounted automatically. You can check the location of the USB disk by mount command. The UC-8410/8416/8418/8430/8430 will be un-mounted automatically with **umount** when the device is disconnected.



### ATTENTION

Remember to type the **#sync** command before you disconnect the USB mass storage device. If you don't issue the command, you may lose some data.

Remember to exit the mount directory when you disconnect the USB mass storage device. If you stay in mount directory, the auto un-mount process will fail. If that happens, type **#umount** mount directory to un-mount the USB device manually. For example, type **#umount /mnt/sdc**.

The UC-8410/8416/8418/8430/8430 only supports certain types of flash disk USB Mass Storage devices. Some USB flash disks and hard disks may not be compatible with the UC-8410/8416/8418/8430. Check compatibility issues before you purchase a USB device to connect to the UC-8410/8416/8418/8430.

## CF Mass Storage

The UC-8410/8416/8418/8430/8430 Embedded Computer does not support CompactFlash hot swap and PnP (Plug and Play) function. It is necessary to remove power source first before inserting or removing the CompactFlash card. The UC-8410/8416/8418/8430/8430 CF card doesn't support PNP. This means that user need to mount the CF card manually after inserting the CF mass storage.

You can mount the CF card manually with the command below:

**Moxa: ~# mkdir /home/sda**

**Moxa: ~# mount -t ext2 /dev/sda1 /home/sda**

You should umount the CF mass storage before you remove the CF card.

**Moxa: ~# umount /home/sda**

# Managing Communication

---

In this chapter, we explain how to configure the UC-8410/8416/8418/8430's various communication functions.

The following topics are covered in this chapter:

- ❑ **Telnet/FTP**
- ❑ **DNS**
- ❑ **Web Service—Apache**
- ❑ **IPTABLES**
- ❑ **NAT**
  - NAT Example
  - Enabling NAT at Bootup
- ❑ **Dial-up Service—PPP**
- ❑ **PPPoE**
- ❑ **NFS (Network File System) Client**
  - Setting up the UC-8410/8416/8418/8430/8430 as an NFS Client
- ❑ **Mail**
- ❑ **SNMP**
- ❑ **OpenVPN**
- ❑ **Package Management—ipkg**
- ❑ **Audio Playing and Recording**
  - Volume Control
  - Playing a WAVE File
  - Recording a WAVE file

## Telnet/FTP

In addition to supporting Telnet client/server and FTP client/server, the UC-8410/8416/8418/8430/8430 also supports SSH and sftp client/server. To enable or disable the Telnet/ftp server, you first need to edit the file `/etc/inetd.conf`.

### Enabling the Telnet/ftp server

The following example shows the default content of the file `/etc/inetd.conf`. The default is to enable the Telnet/ftp server:

```
discard dgram udp wait root /bin/discard
discard stream tcp nowait root /bin/discard
telnet stream tcp nowait root /bin/telnetd
ftp stream tcp nowait root /bin/ftpd -l
```

### Disabling the Telnet/ftp server

Disable the daemon by typing `#` in front of the first character of the row to comment out the line.

## DNS

The UC-8410/8416/8418/8430/8430 supports DNS client (but not DNS server). To set up DNS client, you need to edit three configuration files: `/etc/hosts`, `/etc/resolv.conf`, and `/etc/nsswitch.conf`.

### `/etc/hosts`

This is the first file that the Linux system reads to resolve the host name and IP address.

### `/etc/resolv.conf`

This is the most important file that you need to edit when using DNS for the other programs. For example, before using `#ntpdate time.nist.gov` to update the system time, you will need to add the DNS server address to the file. Ask your network administrator which DNS server address you should use. The DNS server's IP address is specified with the `"nameserver"` command. For example, add the following line to `/etc/resolv.conf` if the DNS server's IP address is 168.95.1.1:

```
nameserver 168.95.1.1
```

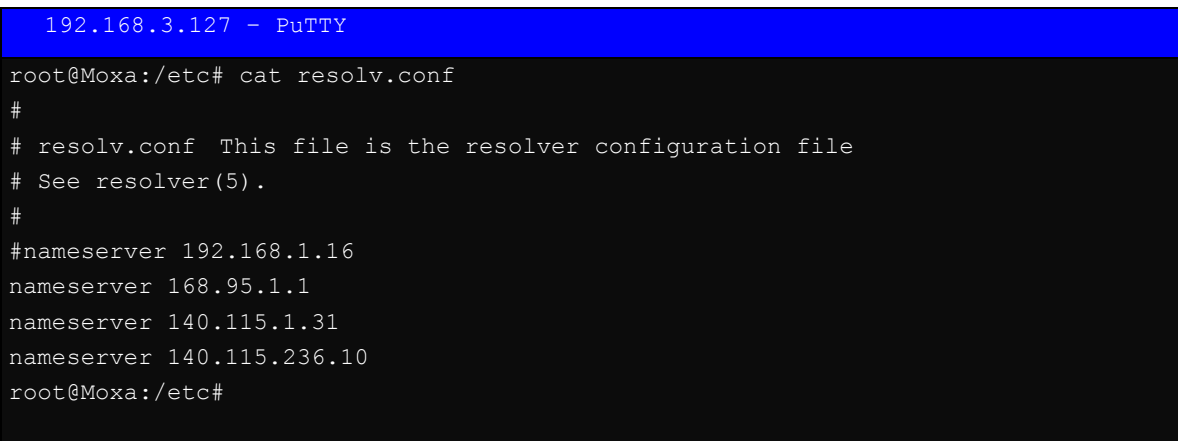

```
192.168.3.127 - PuTTY
root@Moxa:/etc# cat resolv.conf
#
# resolv.conf This file is the resolver configuration file
# See resolver(5).
#
#nameserver 192.168.1.16
nameserver 168.95.1.1
nameserver 140.115.1.31
nameserver 140.115.236.10
root@Moxa:/etc#
```

### `/etc/nsswitch.conf`

This file defines the sequence to resolve the IP address by using `/etc/hosts` file or `/etc/resolv.conf`.

# Web Service—Apache

The Apache web server's main configuration file is `/etc/apache/conf/httpd.conf`, with the default homepage located at `/home/httpd/htdocs/index.html`. Save your own homepage to the following directory:

`/home/httpd/htdocs/`

Save your CGI page to the following directory:

`/home/httpd/cgi-bin/`

Before you modify the homepage, use a browser (such as Microsoft Internet Explorer or Mozilla Firefox) from your PC to test if the Apache Web Server is working. Type the LAN1 IP address in the browser's address box to open the homepage. E.g., if the default IP address is still active, type `http://host-ip-address` in address box.

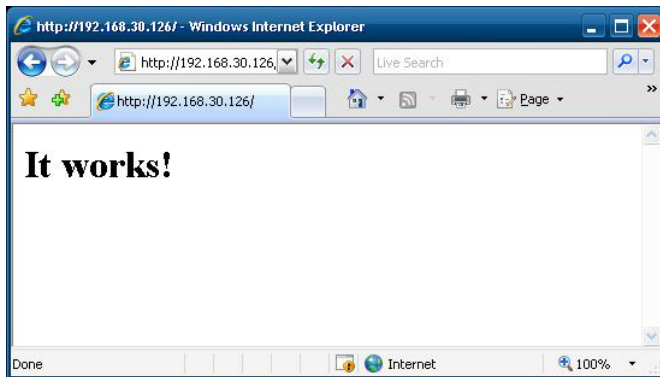

To open the default CGI page, type `http://host-ip-address/cgi-bin/xxx.cgi` (`xxx` is your CGI page) in your browser's address box.

To open the default CGI test script report page, type `http://host-ip-address/cgi-bin/test-cgi` in your browser's address box.

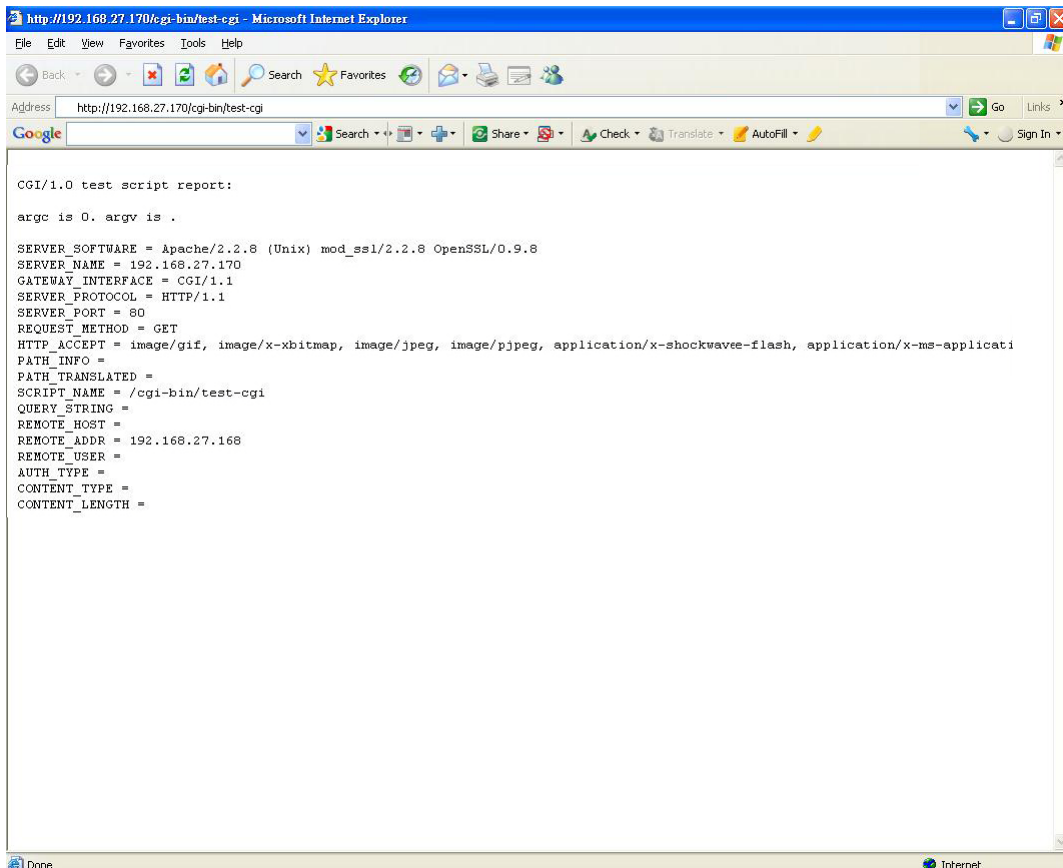

**ATTENTION**

When you develop your own CGI application, make sure your CGI file is executable.

```
192.168.3.127 - PuTTY
root@Moxa:/usr/www/cgi-bin# ls -al
drwxr-xr-x  2 root  root           0 Aug 24 1999
drwxr-xr-x  5 root  root           0 Nov  5 16:16
-rwxr-xr-x  1 root  root        268 Dec 19 2002 printenv
-rwxr-xr-x  1 root  root        757 Aug 24 1999 test-cgi
root@Moxa:/usr/www/cgi-bin#
```

## IPTABLES

IPTABLES is an administrative tool for setting up, maintaining, and inspecting the Linux kernel's IP packet filter rule tables. Several different tables are defined, with each table containing built-in chains and user-defined chains.

Each chain is a list of rules that apply to a certain type of packet. Each rule specifies what to do with a matching packet. A rule (such as a jump to a user-defined chain in the same table) is called a "target."

The UC-8410/8416/8418/8430/8430 supports 3 types of IPTABLES table: Filter tables, NAT tables, and Mangle tables:

**A. Filter Table**—includes three chains:

- INPUT chain
- OUTPUT chain
- FORWARD chain

**B. NAT Table**—includes three chains:

- PREROUTING chain—transfers the destination IP address (DNAT)
- POSTROUTING chain—works after the routing process and before the Ethernet device process to transfer the source IP address (SNAT)
- OUTPUT chain—produces local packets
  - sub-tables*
  - Source NAT (SNAT)—changes the first source packet IP address
  - Destination NAT (DNAT)—changes the first destination packet IP address
  - MASQUERADE—a special form for SNAT. If one host can connect to internet, then other computers that connect to this host can connect to the Internet when it the computer does not have an actual IP address.
  - REDIRECT—a special form of DNAT that re-sends packets to a local host independent of the destination IP address.

**C. Mangle Table**—includes two chains

- PREROUTING chain—pre-processes packets before the routing process.
- OUTPUT chain—processes packets after the routing process. It has three extensions—TTL, MARK, TOS.

The following figure shows the IPTABLES hierarchy.

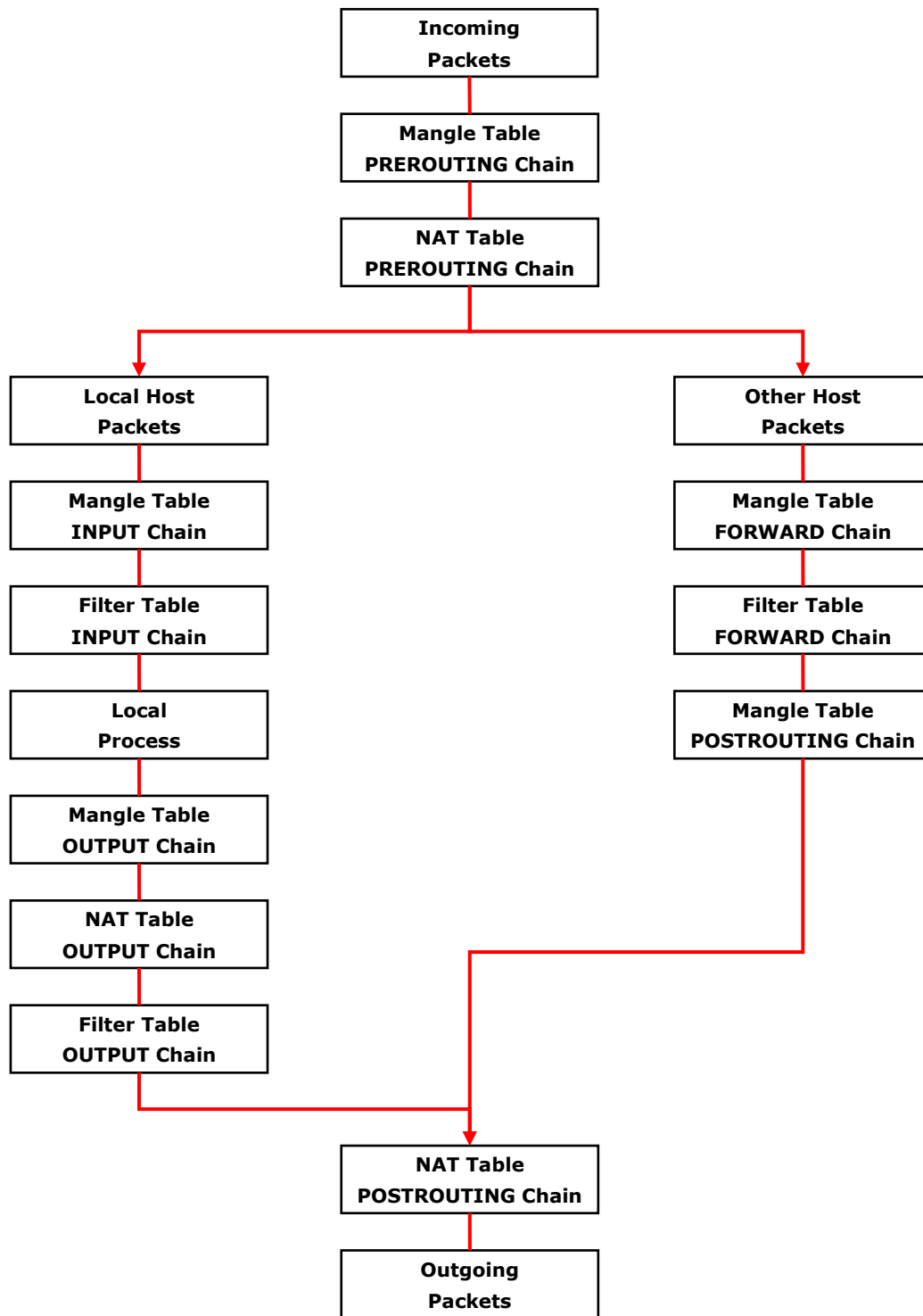



The UC-8410/8416/8418/8430/8430 supports the following sub-modules. Be sure to use the module that matches your application.

nf_conntrack	nf_conntrack_ftp	x_tables	xt_CLASSIFY
xt_MARK	xt_NFLOG	xt_NFQUEUE	xt_TCPMSS
xt_esp	xt_length	xt_limit	xt_mac
xt_mark	xt_multiport	xt_pkttype	xt_string
xt_tcpmss	xt_tcpudp	xt_u32	arp_tables
arpt_mangle	arptable_filter	ip_tables	ipt_CLUSTERIP
ipt_ECN	ipt_NETMAP	ipt_SAME	ipt_TTL
ipt_addrtype	ipt_ecn	ipt_iprange	ipt_recent
iptable_filter	iptable_mangle	iptable_nat	nf_conntrack_ipv4
nf_nat	nf_nat_ftp	nf_nat_snmp_basic	
		ipt_ah	
	ipt_MASQUERADE		
			ipt_tos
	ipt_REDIRECT		ipt_ttl
	ipt_REJECT		
	ipt_TOS		
ipt_LOG	ipt_ULOG	ipt_owner	

**NOTE** The UC-8410/8416/8418/8430/8430 does NOT support IPV6 and ipchains.

The basic syntax to enable and load an IPTABLES module is as follows:

```
#lsmod
#modprobe ip_tables
#modprobe iptable_filter
```

Use **lsmod** to check if the ip\_tables module has already been loaded in the UC-8410/8416/8418/8430. Use **modprobe** to insert and enable the module.

Use the following command to load the modules (iptable\_filter, iptable\_mangle, iptable\_nat):

```
#modprobe iptable_filter
```

**NOTE** IPTABLES plays the role of packet filtering or NAT. Take care when setting up the IPTABLES rules. If the rules are not correct, remote hosts that connect via a LAN or PPP may be denied access. We recommend using the serial console to set up the IPTABLES.

Click on the following links for more information about iptables.

<http://www.linuxguruz.com/iptables/>

<http://www.netfilter.org/documentation/HOWTO//packet-filtering-HOWTO.html>

Since the IPTABLES command is very complex, to illustrate the IPTABLES syntax we have divided our discussion of the various rules into three categories: **Observe and erase chain rules**, **Define policy rules**, and **Append or delete rules**.

## Observe and erase chain rules

### Usage:

```
# iptables [-t tables] [-L] [-n]
```

- t tables: Table to manipulate (default: 'filter'); example: nat or filter.
- L [chain]: List List all rules in selected chains. If no chain is selected, all chains are listed.
- n: Numeric output of addresses and ports.

```
# iptables [-t tables] [-FXZ]
```

- F: Flush the selected chain (all the chains in the table if none is listed).
- X: Delete the specified user-defined chain.
- Z: Set the packet and byte counters in all chains to zero.

**Examples:**

```
# iptables -L -n
```

In this example, since we do not use the -t parameter, the system uses the default 'filter' table. Three chains are included: INPUT, OUTPUT, and FORWARD. INPUT chains are accepted automatically, and all connections are accepted without being filtered.

```
#iptables -F
#iptables -X
#iptables -Z
```

## Define policy for chain rules

**Usage:**

```
# iptables [-t tables] [-P] [INPUT, OUTPUT, FORWARD, PREROUTING, OUTPUT, POSTROUTING]
[ACCEPT, DROP]
```

- P: Set the policy for the chain to the given target.
- INPUT: For packets coming into the UC-8410/8416/8418/8430.
- OUTPUT: For locally-generated packets.
- FORWARD: For packets routed out through the UC-8410/8416/8418/8430.
- PREROUTING: To alter packets as soon as they come in.
- POSTROUTING: To alter packets as they are about to be sent out.

**Examples:**

```
#iptables -P INPUT DROP
#iptables -P OUTPUT ACCEPT
#iptables -P FORWARD ACCEPT
# modprobe iptable_nat
#iptables -t nat -P PREROUTING ACCEPT
#iptables -t nat -P OUTPUT ACCEPT
#iptables -t nat -P POSTROUTING ACCEPT
```

In this example, the policy accepts outgoing packets and denies incoming packets.

## Append or delete rules:

**Usage:**

```
# iptables [-t table] [-AI] [INPUT, OUTPUT, FORWARD] [-io interface] [-p tcp, udp,
icmp, all] [-s IP/network] [--sport ports] [-d IP/network] [--dport ports] -j [ACCEPT.
DROP]
```

- A: Append one or more rules to the end of the selected chain.
- I: Insert one or more rules in the selected chain as the given rule number.
- i: Name of an interface via which a packet is going to be received.
- o: Name of an interface via which a packet is going to be sent.
- p: The protocol of the rule or of the packet to check.
- s: Source address (network name, host name, network IP address, or plain IP address).
- sport: Source port number.
- d: Destination address.

--dport: Destination port number.  
-j: Jump target. Specifies the target of the rules; i.e., how to handle matched packets. For example, ACCEPT the packet, DROP the packet, or LOG the packet.

**Examples:**

Example 1: Accept all packets from lo interface.

```
# iptables -A INPUT -i lo -j ACCEPT
```

Example 2: Accept TCP packets from 192.168.0.1.

```
# iptables -A INPUT -i eth0 -p tcp -s 192.168.0.1 -j ACCEPT
```

Example 3: Accept TCP packets from Class C network 192.168.1.0/24.

```
# iptables -A INPUT -i eth0 -p tcp -s 192.168.1.0/24 -j ACCEPT
```

Example 4: Drop TCP packets from 192.168.1.25.

```
# iptables -A INPUT -i eth0 -p tcp -s 192.168.1.25 -j DROP
```

Example 5: Drop TCP packets addressed for port 21.

```
# modprobe xt_tcpudp  
# iptables -A INPUT -i eth0 -p tcp --dport 21 -j DROP
```

Example 6: Accept TCP packets from 192.168.0.24 to LAN1 port 137, 138, 139

```
# iptables -A INPUT -i eth0 -p tcp -s 192.168.0.24 --dport 137:139 -j ACCEPT
```

Example 7: Log TCP packets that visit the LAN1 port 25.

```
# iptables -A INPUT -i eth0 -p tcp --dport 25 -j LOG
```

Example 8: Drop all packets from MAC address 01:02:03:04:05:06.

```
# modprobe xt_mac  
# iptables -A INPUT -i eth0 -p all -m mac --mac-source 01:02:03:04:05:06 -j DROP
```

**NOTE:** In Example 8, remember to issue the command `#modprobe ipt_mac` first to load the module `xt_mac`

## NAT

NAT (Network Address Translation) protocol translates IP addresses used on one network to different IP addresses used on another network. One network is designated the inside network and the other is the outside network. Typically, the UC-8410/8416/8418/8430/8430 connects several devices on a network and maps local inside network addresses to one or more global outside IP addresses, and un-maps the global IP addresses on incoming packets back into local IP addresses.

**NOTE** Click the following link for more information about iptables and NAT:

<http://www.netfilter.org/documentation/HOWTO/NAT-HOWTO.html>

## NAT Example

The IP address of LAN1 is changed to 192.168.3.127 (you will need to load the module ipt\_MASQUERADE):

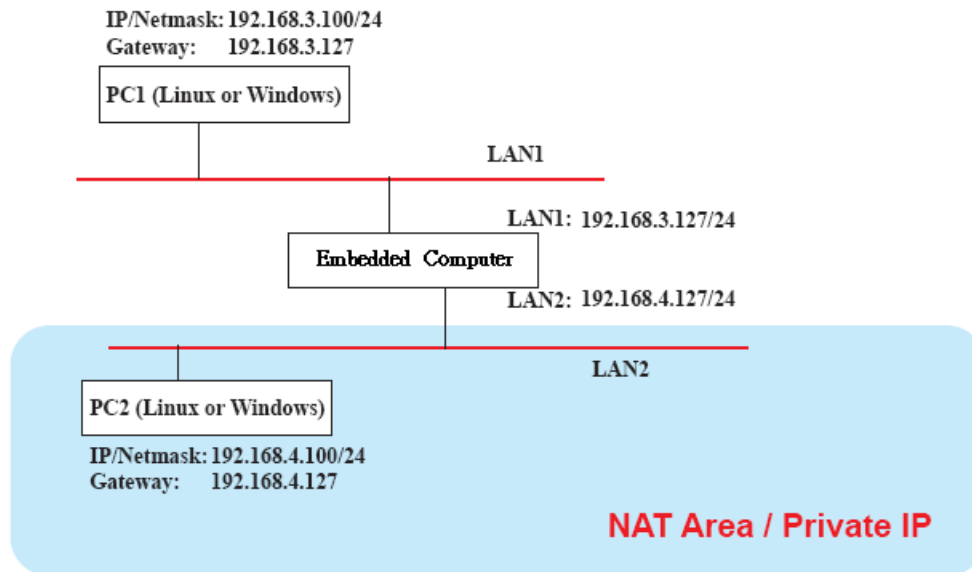

1. #echo 1 > /proc/sys/net/ipv4/ip\_forward
2. #modprobe ip\_tables
3. #modprobe iptable\_filter
4. #modprobe ip\_conntrack
5. #modprobe iptable\_nat
6. #modprobe ipt\_MASQUERADE
7. #iptables -t nat -A POSTROUTING -o eth0 -j SNAT --to-source 192.168.3.127  
or  
#iptables -t nat -A POSTROUTING -o eth0 -j MASQUERADE

## Enabling NAT at Bootup

In most real world situations, you will want to use a simple shell script to enable NAT when the UC-8410/8416/8418/8430/8430 boots up. The following script is an example.

```
#!/bin/bash
# If you put this shell script in the /home/nat.sh
# Remember to chmod 744 /home/nat.sh
# Edit the rc.local file to make this shell startup automatically.
# vi /etc/rc.d/rc.local
# Add a line in the end of rc.local /home/nat.sh
EXIF='eth0' #This is an external interface for setting up a valid IP address.
EXNET='192.168.4.0/24' #This is an internal network address.
# Step 1. Insert modules.
# Here 2> /dev/null means the standard error messages will be dump to null device.
modprobe ip_tables 2> /dev/null
modprobe iptable_filter 2> /dev/null
modprobe iptable_nat 2> /dev/null
modprobe ip_conntrack 2> /dev/null
modprobe ip_conntrack_ftp 2> /dev/null
modprobe iptable_nat
modprobe ip_nat_ftp 2> /dev/null
# Step 2. Define variables, enable routing and erase default rules.
PATH=/bin:/sbin:/usr/bin:/usr/sbin:/usr/local/bin:/usr/local/sbin
```

```

export PATH
echo "1" > /proc/sys/net/ipv4/ip_forward
/sbin/iptables -F
/sbin/iptables -X
/sbin/iptables -Z
/sbin/iptables -F -t nat
/sbin/iptables -X -t nat
/sbin/iptables -Z -t nat
/sbin/iptables -P INPUT ACCEPT
/sbin/iptables -P OUTPUT ACCEPT
/sbin/iptables -P FORWARD ACCEPT
/sbin/iptables -t nat -P PREROUTING ACCEPT
/sbin/iptables -t nat -P POSTROUTING ACCEPT
/sbin/iptables -t nat -P OUTPUT ACCEPT
# Step 3. Enable IP masquerade.

```

## Dial-up Service—PPP

PPP (Point to Point Protocol) is used to run IP (Internet Protocol) and other network protocols over a serial link. PPP can be used for direct serial connections (using a null-modem cable) over a Telnet link, and links established using a modem over a telephone line.

Modem/PPP access is almost identical to connecting directly to a network through the UC-8410/8416/8418/8430's Ethernet port. Since PPP is a peer-to-peer system, the UC-8410/8416/8418/8430/8430 can also use PPP to link two networks (or a local network to the Internet) to create a Wide Area Network (WAN).

**NOTE** Click on the following links for more information about ppp:

<http://tldp.org/HOWTO/PPP-HOWTO/index.html>  
<http://axion.physics.ubc.ca/ppp-linux.html>

The pppd daemon is used to connect to a PPP server from a Linux system. For detailed information about pppd see the man page.

### Example 1: Connecting to a PPP server over a simple dial-up connection

The following command is used to connect to a PPP server by modem. Use this command for old ppp servers that prompt for a login name (replace username with the correct name) and password (replace password with the correct password). Note that debug and defaultroute *192.1.1.17* are optional.

```
#pppd connect 'chat -v " " ATDT5551212 CONNECT' " ogin: username word: password'
/dev/ttyM0 115200 debug crtscts modem defaultroute
```

If the PPP server does not prompt for the username and password, the command should be entered as follows. Replace username with the correct username and replace password with the correct password.

```
#pppd connect 'chat -v " " ATDT5551212 CONNECT' " ` user username password password
/dev/ttyM0 115200 crtscts modem
```

The pppd options are described below:

```
connect 'chat etc...'
```

This option gives the command to contact the PPP server. The 'chat' program is used to dial a remote computer. The entire command is enclosed in single quotes because pppd expects a one-word argument for the 'connect' option. The options for 'chat' are given below:

```

-v
verbose mode; log what we do to syslog

" "
Double quotes—don't wait for a prompt, but instead do (note that you must include a space after the second
quotation mark)

ATDT5551212
Dial the modem, and then ...

CONNECT
Wait for an answer.

" "
Send a return (null text followed by the usual return)

ogin:  username word: password
Log in with username and password.

Refer to the chat man page, chat.8, for more information about the chat utility.

/dev/
Specify the callout serial port.

115200
The baudrate.

Debug
Log status in syslog.

Crtscts
Use hardware flow control between the computer and modem (at 115200 this is a must).

Modem
Indicates that this is a modem device; pppd will hang up the phone before and after making the call.

Defaultroute
Once the PPP link is established, make it the default route; if you have a PPP link to the Internet, this is probably
what you want.

192.1.1.17
This is a degenerate case of a general option of the form x.x.x.x:y.y.y.y. Here x.x.x.x is the local IP address and
y.y.y.y is the IP address of the remote end of the PPP connection. If this option is not specified, or if just one
side is specified, then x.x.x.x defaults to the IP address associated with the local machine's hostname (located
in /etc/hosts), and y.y.y.y is determined by the remote machine.

```

## Example 2: Connecting to a PPP server over a hard-wired link

If a username and password are not required, use the following command (note that noipdefault is optional):

```
#pppd connect `chat -v" " " " \ noipdefault /dev/ttyM0 19200 crtscts
```

If a username and password is required, use the following command (note that noipdefault is optional, and root is both the username and password):

```
#pppd connect `chat -v" " " " \ user root password root noipdefault
/dev/ttyM0 19200 crtscts
```

## How to check the connection

Once you've set up a PPP connection, there are some steps you can take to test the connection. First, type:

```
/sbin/ifconfig
```

(The folder **ifconfig** may be located elsewhere, depending on your distribution.) You should be able to see all of the network interfaces that are UP. ppp0 should be one of them, and you should recognize the first IP address as your own. In addition, the "P-t-P address" (or point-to-point address) is the address of your server. Here's what it looks like on one machine:

lo	Link encap Local Loopback
	inet addr 127.0.0.1 Bcast 127.255.255.255 Mask 255.0.0.0
	UP LOOPBACK RUNNING MTU 2000 Metric 1
	RX packets 0 errors 0 dropped 0 overrun 0
ppp0	Link encap Point-to-Point Protocol
	inet addr 192.76.32.3 P-t-P 129.67.1.165 Mask 255.255.255.0
	UP POINTOPOINT RUNNING MTU 1500 Metric 1
	RX packets 33 errors 0 dropped 0 overrun 0
	TX packets 42 errors 0 dropped 0 overrun 0

Now, type:

```
ping z.z.z.z
```

where z.z.z.z is the address of your name server. This should work. Here's what the response could look like:

waddington:~\$	ping 129.67.1.165
	PING 129.67.1.165 (129.67.1.165): 56 data bytes
	64 bytes from 129.67.1.165: icmp_seq=0 ttl=225 time=268 ms
	64 bytes from 129.67.1.165: icmp_seq=1 ttl=225 time=247 ms
	64 bytes from 129.67.1.165: icmp_seq=2 ttl=225 time=266 ms
	^C
	--- 129.67.1.165 ping statistics ---
	3 packets transmitted, 3 packets received, 0% packet loss
	round-trip min/avg/max = 247/260/268 ms
waddington:~\$	

Try typing:

```
netstat -nr
```

You should see three routes, similar to the following:

Kernel routing table						
Destination	Gateway	Genmask	Flags	Metric	Ref	Use
iface						
129.67.1.165	0.0.0.0	255.255.255.255	UH	0	0	6
ppp0						
127.0.0.0	0.0.0.0	255.0.0.0	U	0	0	0 lo
0.0.0.0	129.67.1.165	0.0.0.0	UG	0	0	6298
ppp0						

If your output looks similar, but does not have the destination 0.0.0.0 line (which refers to the default route used for connections), you may have run pppd without the 'defaultroute' option. At this point you can try using Telnet, ftp, or finger, bearing in mind that you will need to use numeric IP addresses unless you've set up /etc/resolv.conf correctly.

## Setting up a Machine for Incoming PPP Connections

This first example applies to using a modem, and requires authorization with a username and password.

```
pppd/dev/ttyM0 115200 crtscts modem 192.168.16.1:192.168.16.2 login auth
```

You should also add the following line to the file `/etc/ppp/pap-secrets`:

```
* * "" *
```

The first star (\*) lets everyone login. The second star (\*) lets every host connect. The pair of double quotation marks ("" ) is to use the file `/etc/passwd` to check the password. The last star (\*) is to let any IP connect.

The following example does not check the username and password:

```
pppd/dev/ttyM0 115200 crtscts modem 192.168.16.1:192.168.16.2
```

## PPPoE

1. Connect the UC-8410/8416/8418/8430's LAN port to an ADSL modem with a cross-over cable, HUB, or switch.
2. Log in to the UC-8410/8416/8418/8430/8430 as the root user.
3. Edit the file `/etc/ppp/chap-secrets` and add the following:

```
"username@hinet.net" * "password" *
```

```
192.168.3.127 - PuTTY
# Secrets for authentication using CHAP
# client      server  secret                IP addresses

# PPPOE example, if you want to use it, you need to unmark it and modify it
"username@hinet.net" * "password" *
```

`"username@hinet.net"` is the username obtained from the ISP to log in to the ISP account.

`"password"` is the corresponding password for the account.

4. Edit the file `/etc/ppp/pap-secrets` and add the following:

```
"username@hinet.net" * "password" *
```

```
192.168.3.127 - PuTTY
support hostname    "*" -
stats  hostname    "*" -

# OUTBOUND connections
# ATTENTION: The definitions here can allow users to login without a
# package already provides this option; make sure you don't change that.

# INBOUND connections

# Every regular user can use PPP and has to use passwords from /etc/passwd
*      hostname    ""      *
"username@hinet.net" * "password" *

# PPPOE user example, if you want to use it, you need to unmark it and modify it
#"username@hinet.net" * "password" *

# UserIDs that cannot use PPP at all. Check your /etc/passwd and add any
```



```
# other accounts that should not be able to use pppd!
guest hostname "*" -
master hostname "*" -
root hostname "*" -
support hostname "*" -
stats hostname "*" -
```

"**username@hinet.net**" is the username obtained from the ISP to log in to the ISP account. "**password**" is the corresponding password for the account.

5. Edit the file **/etc/ppp/options** and add the following line:

```
plugin pppoe
```

```
192.168.3.127 - PuTTY
# Wait for up n milliseconds after the connect script finishes for a valid
# PPP packet from the peer. At the end of this time, or when a valid PPP
# packet is received from the peer, pppd will commence negotiation by
# sending its first LCP packet. The default value is 1000 (1 second).
# This wait period only applies if the connect or pty option is used.
#connect-delay <n>

# Load the pppoe plugin
plugin /lib/rp-pppoe.so

# ---<End of File>---
```

6. Add one of two files: **/etc/ppp/options.eth0** or **/etc/ppp/options.eth1**. The choice depends on which LAN is connected to the ADSL modem. If you use LAN1 to connect to the ADSL modem, then add **/etc/ppp/options.eth0**. If you use LAN2 to connect to the ADSL modem, then add **/etc/ppp/options.eth1**. The file context is shown below:

```
192.168.3.127 - PuTTY
name username@hinet.net
mtu 1492
mru 1492
defaultroute
noipdefault
```

Type your username (the one you set in the **/etc/ppp/pap-secrets** and **/etc/ppp/chap-secrets** files) after the "name" option. You may add other options as desired.

7. Set up DNS.

If you are using DNS servers supplied by your ISP, edit the file **/etc/resolv.conf** by adding the following lines of code:

```
nameserver ip_addr_of_first_dns_server
nameserver ip_addr_of_second_dns_server
```

For example:

```
nameserver 168.95.1.1
nameserver 139.175.10.20
```

8. Use the following command to create a pppoe connection:

```
pppd eth0
```

The eth0 is what is connected to the ADSL modem LAN port. The example above uses LAN1. To use LAN2, type:

```
pppd eth1
```

9. Type **ifconfig ppp0** to check if the connection is OK or has failed. If the connection is OK, you will see information about the ppp0 setting for the IP address. Use ping to test the IP.
10. If you want to disconnect it, use the kill command to kill the pppd process.

## NFS (Network File System) Client

The Network File System (NFS) is used to mount a disk partition on a remote machine, as if it were on a local hard drive, allowing fast, seamless sharing of files across a network. NFS allows users to develop applications for the UC-8410/8416/8418/8430, without worrying about the amount of disk space that will be available. The UC-8410/8416/8418/8430/8430 supports NFS protocol for client.

**NOTE** Click on the following links for more information about NFS:

<http://www.tldp.org/HOWTO/NFS-HOWTO/index.html>

<http://nfs.sourceforge.net/nfs-howto/client.html>

<http://nfs.sourceforge.net/nfs-howto/server.html>

## Setting up the UC-8410/8416/8418/8430/8430 as an NFS Client

The following procedure is used to mount a remote NFS Server.

1. Establish a mount point on the NFS Client site.
2. Mount the remote directory to a local directory.

Steps 1:

```
#mkdir -p /home/nfs/public
```

Step 2:

```
#mount -t nfs NFS_Server(IP):/directory /mount/point
```

Example

```
: #mount -t nfs 192.168.3.100/home/public /home/nfs/public
```

## Mail

smtpclient is a minimal SMTP client that takes an email message body and passes it on to an SMTP server. It is suitable for applications that use email to send alert messages or important logs to a specific user.

**NOTE** Click on the following link for more information about smtpclient:

<http://www.engelschall.com/sw/smtpclient/>

To send an email message, use the 'smtpclient' utility, which uses SMTP protocol. Type **#smtpclient--help** to see the help message.

**Example:**

```
smtpclient -s test -f sender@company.com -S IP_address receiver@company.com
< mail-body-message
```

**-s:** The mail subject.

**-f:** Sender's mail address

**-S:** SMTP server IP address

The last mail address **receiver@company.com** is the receiver's e-mail address.

**mail-body-message** is the mail content. The last line of the body of the message should contain ONLY the period '.' character.

You will need to add your hostname to the file **/etc/hosts**.

## SNMP

The UC-8410/8416/8418/8430/8430 has the SNMP V1 (Simple Network Management Protocol) agent software built in. It supports RFC1317 RS-232 like groups and RFC 1213 MIB-II.

The following simple example allows you to use an SNMP browser on the host site to query the UC-8410/8416/8418/8430, which is the SNMP agent. The UC-8410/8416/8418/8430/8430 will respond.

```
debian:~# snmpwalk -v 1 -c public -Cc 192.168.30.127
```

```
SNMPv2-MIB::sysDescr.0 = STRING: Linux version 2.6.23.1 (root@UC8400) (gcc version 4.2.1) #1137 Wed
Sep 17 16:17:45 EDT 2008
```

```
SNMPv2-MIB::sysObjectID.0 = OID: SNMPv2-SMI::enterprises.8691.12.8410/8416/8418
```

```
DISMAN-EVENT-MIB::sysUpTimeInstance = Timeticks: (239600) 0:39:56.00
```

```
SNMPv2-MIB::sysContact.0 = STRING: Moxa Systems Co., LDT.
```

```
SNMPv2-MIB::sysName.0 = STRING: (none)
```

```
SNMPv2-MIB::sysLocation.0 = STRING: Unknown
```

```
SNMPv2-MIB::sysServices.0 = INTEGER: 6
```

```
IF-MIB::ifNumber.0 = INTEGER: 11
```

```
IF-MIB::ifIndex.1 = INTEGER: 1
```

```
IF-MIB::ifIndex.2 = INTEGER: 2
```

```
IF-MIB::ifIndex.3 = INTEGER: 3
```

```
IF-MIB::ifIndex.4 = INTEGER: 4
```

```
IF-MIB::ifIndex.5 = INTEGER: 5
```

```
IF-MIB::ifIndex.6 = INTEGER: 6
```

```
IF-MIB::ifIndex.7 = INTEGER: 7
```

```
IF-MIB::ifIndex.8 = INTEGER: 8
```

```
IF-MIB::ifIndex.9 = INTEGER: 9
```

```
IF-MIB::ifIndex.10 = INTEGER: 10
```

```
IF-MIB::ifIndex.11 = INTEGER: 11
```

```
IF-MIB::ifDescr.1 = STRING: eth0
```

```
IF-MIB::ifDescr.2 = STRING: eth1
```

```
IF-MIB::ifDescr.3 = STRING: eth2***** SNMP QUERY FINISHED *****
```

**NOTE** Click on the following links for more information about MIB II and RS-232 like groups:

<http://www.faqs.org/rfcs/rfc1213.html>

<http://www.faqs.org/rfcs/rfc1317.html>

→ The UC-8410/8416/8418/8430/8430 does NOT support SNMP trap.

The following tables list the variables supported by the UC-8410/8416/8418/8430.

# OpenVPN

OpenVPN provides two types of tunnels for users to implement VPNs: **Routed IP Tunnels** and **Bridged Ethernet Tunnels**. To begin with, check to make sure that the system has a virtual device `/dev/net/tun`. If not, issue the following command:

```
# mknod /dev/net/tun c 10 200
```

An Ethernet bridge is used to connect different Ethernet networks together. The Ethernets are bundled into one bigger, "logical" Ethernet. Each Ethernet corresponds to one physical interface (or port) that is connected to the bridge.

On each OpenVPN machine, you should generate a working directory, such as `/etc/openvpn`, where script files and key files reside. Once established, all operations will be performed in that directory.

## Setup 1: Ethernet Bridging for Private Networks on Different Subnets

1. Set up four machines, as shown in the following diagram.

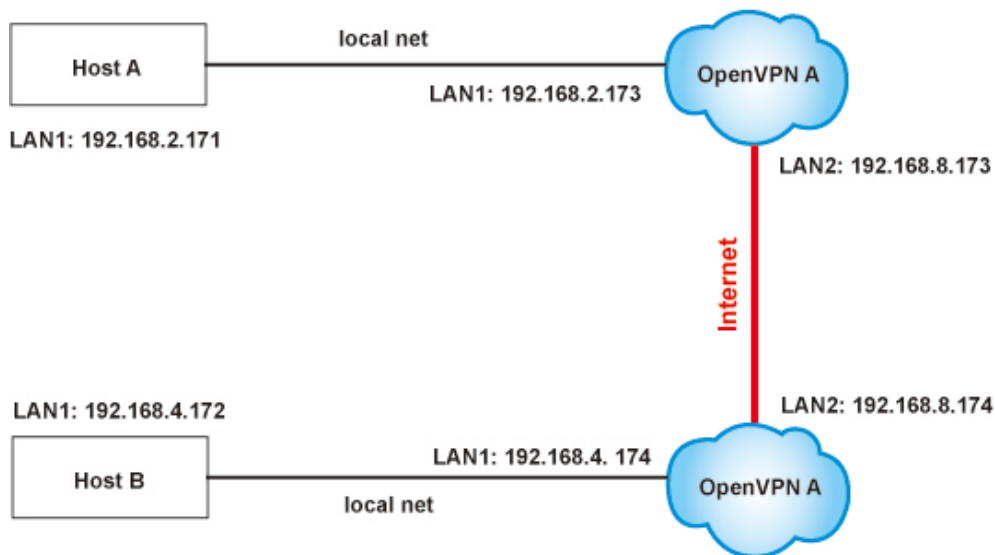

Host A (B) represents one of the machines that belongs to OpenVPN A (B). The two remote subnets are configured for a different range of IP addresses. When this setup is moved to a public network, the external interfaces of the OpenVPN machines should be configured for static IPs, or connect to another device (such as a firewall or DSL box) first.

```
# openvpn --genkey --secret secrouter.key
```

Copy the file that is generated to the OpenVPN machine.

2. The `openvpn-bridge` script file located at `/etc/openvpn/` reconfigures the interface "eth1" as IP-less, creates logical bridge(s) and TAP interfaces, loads modules, and enables IP forwarding.

```
#-----Start-----
#!/bin/sh
iface=eth1      # defines the internal interface
maxtap='expr 1` # defines the number of tap devices. I.e., # of tunnels
IPADDR=
NETMASK=
BROADCAST=
# it is not a great idea but this system doesn't support
# /etc/sysconfig/network-scripts/ifcfg-eth1
ifcfg_vpn()
```

```

{
  while read f1 f2 f3 f4 r3
  do
    if [ "$f1" = "iface" -a "$f2" = "$iface" -a "$f3" = "inet" -a "$f4" =
"static" ];then
      i=`expr 0`
      while :
      do
        if [ $i -gt 5 ]; then
          break
        fi
        i=`expr $i + 1`
        read f1 f2
        case "$f1" in
          address ) IPADDR=$f2
                    ;;
          netmask ) NETMASK=$f2
                    ;;
          broadcast ) BROADCAST=$f2
                      ;;
        esac
      done
      break
    fi
  done < /etc/network/interfaces
}
# get the ip address of the specified interface
mname=
module_up()
{
  oIFS=$IFS
  IFS=`
  `
  FOUND="no"
  for LINE in `lsmod`
  do
    TOK=`echo $LINE | cut -d' ' -f1`
    if [ "$TOK" = "$mname" ]; then
      FOUND="yes";
      break;
    fi
  done
  IFS=$oIFS

  if [ "$FOUND" = "no" ]; then
    modprobe $mname
  fi
}
start()
{
  ifcfg_vpn
  if [ ! \( -d "/dev/net" \) ]; then
    mkdir /dev/net
  fi
}

```

```

if [ ! \( -r "/dev/net/tun" \) ]; then
    # create a device file if there is none
    mknod /dev/net/tun c 10 200
fi
# load modules "tun" and "bridge"
mname=tun
module_up
mname=bridge
module_up
# create an ethernet bridge to connect tap devices, internal interface
brctl addbr br0
brctl addif br0 $iface
# the bridge receives data from any port and forwards it to other ports.

i=`expr 0`
while :
do
    # generate a tap0 interface on tun
    openvpn --mktun --dev tap${i}
    # connect tap device to the bridge
    brctl addif br0 tap${i}

    # null ip address of tap device
    ifconfig tap${i} 0.0.0.0 promisc up

    i=`expr $i + 1`
    if [ $i -ge $maxtap ]; then
        break
    fi
done

# null ip address of internal interface
ifconfig $iface 0.0.0.0 promisc up

# enable bridge ip
ifconfig br0 $IPADDR netmask $NETMASK broadcast $BROADCAST

ipf=/proc/sys/net/ipv4/ip_forward
# enable IP forwarding
echo 1 > $ipf
echo "ip forwarding enabled to"
cat $ipf
}
stop() {
    echo "shutdown openvpn bridge."
    ifcfg_vpn
    i=`expr 0`
    while :
    do
        # disconnect tap device from the bridge
        brctl delif br0 tap${i}
        openvpn --rmtun --dev tap${i}

        i=`expr $i + 1`
        if [ $i -ge $maxtap ]; then

```

```

        break
    fi
done
brctl delif br0 $iface
brctl delbr br0
ifconfig br0 down
ifconfig $iface $IPADDR netmask $NETMASK broadcast $BROADCAST
killall -TERM openvpn
}
case "$1" in
start)
    start
    ;;
stop)
    stop
    ;;
restart)
    stop
    start
    ;;
*)
    echo "Usage: $0 [start|stop|restart]"
    exit 1
esac
exit 0
#----- end -----

```

3. On machine OpenVPN A, modify the remote address in the configuration file, **/etc/openvpn/tap0-br.conf**.

```

# /etc/openvpn/tap0-br.conf
# point to the peer
remote 192.168.8.174
dev tap0
secret /etc/openvpn/secrouter.key
cipher DES-EDE3-CBC
auth MD5
tun-mtu 1500
tun-mtu-extra 64
ping 40
up /etc/openvpn/tap0-br.sh

```

Next, modify the routing table in the **/etc/openvpn/tap0-br.sh** script file.

```

#-----Start-----
#!/bin/sh
# /etc/openvpn/tap0-br.sh
# value after "-net" is the subnet behind the remote peer
route add -net 192.168.4.0 netmask 255.255.255.0 dev br0
#----- end -----

```

On machine OpenVPN B, modify the remote address in the configuration file, **/etc/openvpn/tap0-br.conf**.

```

# /etc/openvpn/tap0-br.conf
# point to the peer
remote 192.168.8.173
dev tap0

```

```
secret /etc/openvpn/secrouter.key
cipher DES-EDE3-CBC
auth MD5
tun-mtu 1500
tun-mtu-extra 64
ping 40
up /etc/openvpn/tap0-br.sh
```

Next, modify the routing table in the `/etc/openvpn/tap0-br.sh` script file.

```
#----- Start-----
#!/bin/sh
# /etc/openvpn/tap0-br.sh
# value after "-net" is the subnet behind the remote peer
route add -net 192.168.2.0 netmask 255.255.255.0 dev br0
#----- end -----
```

**Note:** Select cipher and authentication algorithms by specifying "cipher" and "auth". To see with algorithms are available, type:

```
# openvpn --show-ciphers
# openvpn --show-auths
```

4. After configuring the remote peer, we can load the bridge into kernel, reconfigure eth1, and enable IP forwarding on both OpenVPN machine.

```
# /etc/openvpn/openvpn-bridge start
```

Next, start both OpenVPN peers,

```
# openvpn --config /etc/openvpn/tap0-br.conf &
```

If you see the line "Peer Connection Initiated with 192.168.8.173:5000" on each machine, the connection between OpenVPN machines has been established successfully on UDP port 5000.

**Note:** You can create link symbols to enable the `/etc/openvpn/openvpn-bridge` script at boot time:

```
# ln -s /etc/openvpn/openvpn-bridge /etc/rc.d/rc3.d/S32vpn-br
# ln -s /etc/openvpn/openvpn-bridge /etc/rc.d/rc6.d/K32vpn-br
```

5. On each OpenVPN machine, check the routing table by typing the command:

```
# route
```

Destination	Gateway	Genmsk	Flags	Metric	Ref	Use	Iface
192.168.4.0	*	255.255.255.0	U	0	0	0	br0
192.168.2.0	*	255.255.255.0	U	0	0	0	br0
192.168.8.0	*	255.255.255.0	U	0	0	0	eth0

Interface **eth1** is connected to the bridging interface **br0**, to which device **tap0** also connects, whereas the virtual device **tun** sits on top of **tap0**. This ensures that all traffic from internal networks connected to interface **eth1** that come to this bridge write to the TAP/TUN device that the OpenVPN program monitors. Once the OpenVPN program detects traffic on the virtual device, it sends the traffic to its peer.

6. To create an indirect connection to Host B from Host A, add the following routing item:

```
route add -net 192.168.4.0 netmask 255.255.255.0 dev eth0
```

To create an indirect connection to Host A from Host B, add the following routing item:

```
route add -net 192.168.2.0 netmask 255.255.255.0 dev eth0
```

Now ping Host B from Host A by typing:

```
ping 192.168.4.174
```



A successful ping indicates that you have created a VPN system that only allows authorized users from one internal network to access users at the remote site. For this system, all data is transmitted by UDP packets on port 5000 between OpenVPN peers.

- To shut down OpenVPN programs, type the command:  
`# /etc/openvpn/openvpn-bridge stop`

### Setup 2: Ethernet Bridging for Private Networks on the Same Subnet

- Set up four machines as shown in the following diagram:

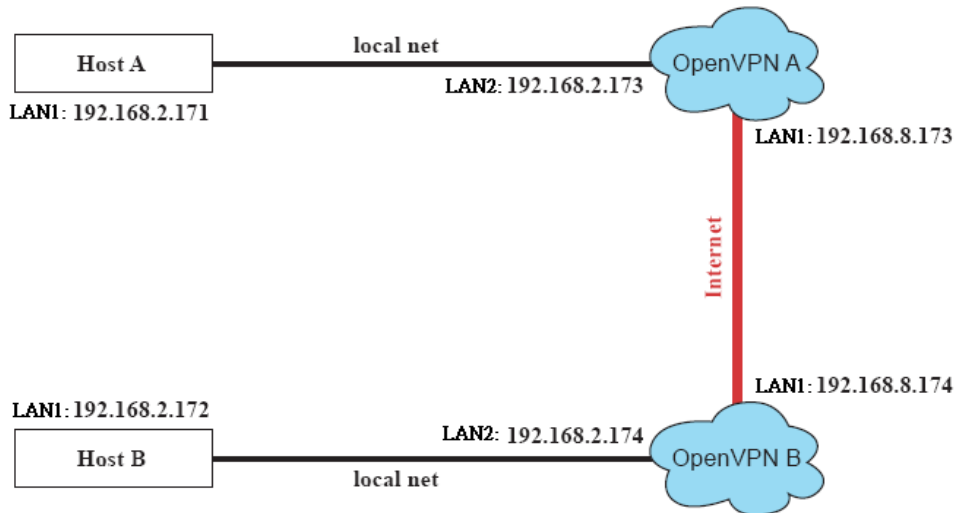

- The configuration procedure is almost the same as for the previous example. The only difference is that you will need to comment out the parameter "up" in "/etc/openvpn/tap0-br.conf" and "/etc/openvpn/tap0-br.conf".

### Setup 3: Routed IP

- Set up four machines as shown in the following diagram:

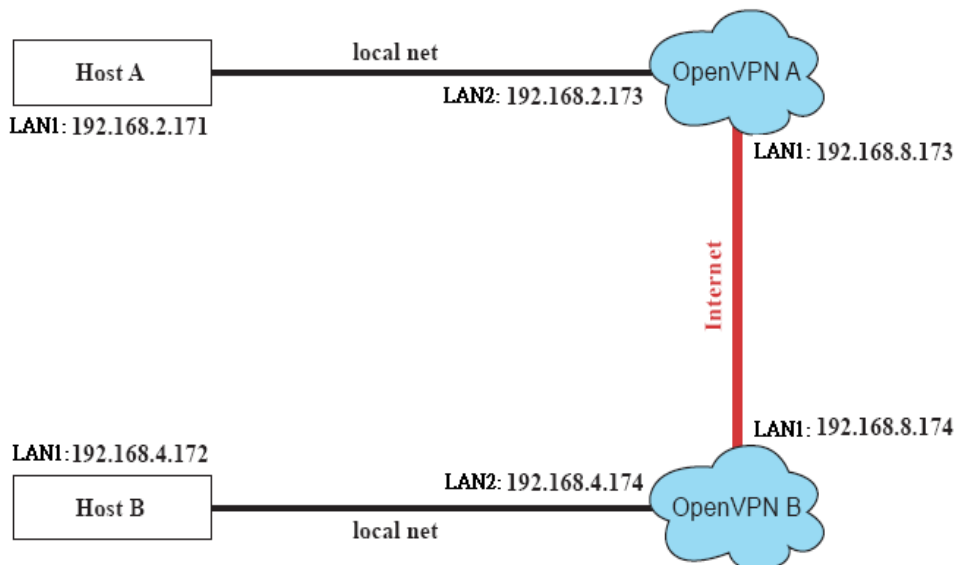

2. On machine OpenVPN A, modify the remote address in the configuration file, **/etc/openvpn/tun.conf**.

```
# point to the peer
remote 192.168.8.174
dev tun
secret /etc/openvpn/secrouter.key
cipher DES-EDE3-CBC
auth MD5
tun-mtu 1500
tun-mtu-extra 64
ping 40
ifconfig 192.168.2.173 192.168.4.174
up /etc/openvpn/tun.sh
```

Next, modify the routing table in the **/etc/openvpn/tun.sh** script file.

```
#----- Start-----
#!/bin/sh
# value after "-net" is the subnet behind the remote peer
route add -net 192.168.4.0 netmask 255.255.255.0 gw $5
#----- end -----
```

On machine OpenVPN B, modify the remote address in the configuration file, **/etc/openvpn/tun.conf**.

```
remote 192.168.8.173
dev tun
secret /etc/openvpn/secrouter.key
cipher DES-EDE3-CBC
auth MD5
tun-mtu 1500
tun-mtu-extra 64
ping 40
ifconfig 192.168.4.174 192.168.2.173
up /etc/openvpn/tun.sh
```

Next, modify the routing table in the **/etc/openvpn/tun.sh** script file.

```
#----- Start-----
#!/bin/sh
# value after "-net" is the subnet behind the remote peer
route add -net 192.168.2.0 netmask 255.255.255.0 gw $5
#----- end -----
```

Note that the parameter "ifconfig" defines the first argument as the local internal interface and the second argument as the internal interface at the remote peer.

Note that **\$5** is the argument that the OpenVPN program passes to the script file. Its value is the second argument of **ifconfig** in the configuration file.

3. Check the routing table after you run the OpenVPN programs, by typing the command:

```
# route
```

Destination	Gateway	Genmsk	Flags	Metric	Ref	Use	Iface
192.168.4.174	*	255.255.255.255	UH	0	0	0	tun0
192.168.4.0	192.168.4.174	255.255.255.0	UG	0	0	0	tun0
192.168.2.0	*	255.255.255.0	U	0	0	0	eth1
192.168.8.0	*	255.255.255.0	U	0	0	0	eth0

# Package Management—ipkg

ipkg is a very lightweight package management system. It also allows for dynamic installation/removal of packages on a running system. Because the disk space is limited, we provide the software as extension packages. You can use ipkg-cl to install or remove .ipk packages on the UC-8410/8416/8418/8430-LX.

## Install an .ipk package via an .ipk file

Upload the .ipk package to the Moxa embedded computer:

```
192.168.3.127 - Putty
Moxa:~# scp /mnt/cdrom/utility_tools/ipkg_packages/libphp5_1.0_xscale.ipk 192.168.3.127:/tmp/
```

Install the uploaded package:

```
192.168.3.127 - Putty
Moxa:~# ipkg-cl install/tmp/libphp5_1.0_xscale.ipk
```

## List the installed packages

```
192.168.3.127 - Putty
Moxa:~# ipkg-cl list_installed
```

## Remove a package

```
192.168.3.127 - Putty
Moxa:~# ipkg-cl remove libphp5
```

# Audio Playing and Recording

The UC-8430 platform comes with audio line-in and line-out ports. We provide the audio playback utility **vplay**, and the audio recording utility **vrec** with this platform.

## Volume Control

### **mixer:**

Use the following commands to control the input and output volume. The volume range is from 0 to 100.  
Device File on Linux: /dev/mixer

```
root@Moxa:/root# mixer vol 100
Usage: mixer vol <value>
```

### Example:

Use the following commands to set the maximum volume.

```
root@Moxa:/root# mixer vol 100
Setting the mixer vol to 100:100.
```

### Example:

Use the following commands to set the left/right channel volume at 70/80.

```
root@Moxa:/root# mixer vol 70:80
Setting the mixer vol to 70:80.
```

## Playing a WAVE File

### vplay:

vplay can be used for playing a wave file. It supports playing mono or stereo wave files at a 11025, 22050, or 44100 HZ sampling rate, with 8 or 16 bits.

Device File on Linux: /dev/dsp

vplay [-qvrS] [-s speed] [-t seconds] -b bits [filename1 ...]

-S	Stereo (default is mono).
-s speed	Sets the speed (default is 11025 kHz). If the speed is less than 300, it will be multiplied by 1000.
-t seconds	Sets the recording (or playback) time in seconds (default is no time limit)
-b bits	Sets the sample size (bits/sample). Possible values are 8 and 16 (default 8).
-w	record a MICROSOFT WAVE file
-r	records raw data without header
-q	quiet mode

Example: Use the following commands to play a WAVE file.

```
root@Moxa:/root# vplay /tmp/test.wav
Playing WAVE : 16 bit, Speed 44100 Hz 16 bits Stereo ...
root@Moxa:/root#
```

## Recording a WAVE file

### vrec:

vrec can be used to record a wave file. It supports playing mono wave files at a 11025, 22050, or 44100 HZ sampling rate, and with 8 or 16 bits.

Device File on Linux: /dev/dsp

vplay [-qvrS] [-s speed] [-t seconds] -b bits [filename1 ...]

-S	Stereo (default is mono).
-s speed	Sets the speed (default is 11025 kHz). If the speed is less than 300, it will be multiplied by 1000.
-t seconds	Sets the recording (or playback) time in seconds (default is no time limit)
-b bits	Sets sample size (bits/sample). Possible values are 8 and 16 (default is 8).
-w	record a MICROSOFT WAVE file
-r	records raw data without a header
-q	quiet mode

Example: Use the following commands to record a mono format WAVE file at a 22050 HZ sampling rate, with 16 bits, in 10 seconds.

```
root@Moxa:/root# vrec -t 10 -w -s 22050 -b 16 /dev/shm/22050_16_Mono.wav
Recording WAVE : 16 bit, Speed 22050 Hz 16 bits Mono ...
root@Moxa:/root#
```

**NOTE** The vrec does not support record the stereo format music.

This chapter includes important information for programmers.

The following topics are covered in this chapter:

- ❑ **Flash Memory Map**
- ❑ **Linux Tool Chain Introduction**
- ❑ **Debugging with GDB**
- ❑ **Device API**
- ❑ **RTC (Real Time Clock)**
- ❑ **Buzzer**
- ❑ **WDT (Watch Dog Timer)**
- ❑ **Digital I/O**
- ❑ **UART**
- ❑ **SRAM**
- ❑ **Make File Example**
- ❑ **Moxa CAN Programming Guide**
  - Introduction
  - Programming Guide
- ❑ **Software Lock**
- ❑ **Qt-embedded**
  - Compile and Test the QT Program on an X86 Machine
  - Set up Qt development
  - Cross-compile the Qt application and run with Dual-display
  - Upload the binary to target and run it with following command

# Flash Memory Map

*Partition sizes are hard coded into the kernel binary. To change partition sizes, you will need to rebuild the kernel. The flash memory map is shown in the following table.*

Address	Size	Contents
0x00000000 – 0x0009FFFF	640 KB	Boot Loader—Read ONLY
0x000A0000 – 0x0027FFFF	1.875 MB	Kernel object code—Read ONLY
0x00280000 – 0x00FDFFFF	13.375 MB	Root file system (JFFS2) —Read ONLY
0x00FE0000 – 0x00FFFFFF	128 KB	Boot Loader configuration and directory—Read ONLY
0x01000000 – 0x01FFFFFF	32 MB	User root file system (JFFS2) —Read/Write
	256 KB	

- NOTE**
1. The default Moxa file system only enables the network. It lets users recover the user file system when it fails.
  2. The user file system is a complete file system. Users can create and delete directories and files (including source code and executable files) as needed.
  3. Users can create the user file system on the PC host or target platform, and then copy it to the UC-8410/8416/8418/8430.

## Linux Tool Chain Introduction

To ensure that an application will be able to run correctly when installed on the UC-8410/8416/8418/8430, you must ensure that it is compiled and linked to the same libraries that will be present on the UC-8410/8416/8418/8430. This is particularly true when the RISC XScale processor architecture of the UC-8410/8416/8418/8430/8430 differs from the CISC x86 processor architecture of the host system, but it is also true if the processor architecture is the same.

The host tool chain that comes with the UC-8410/8416/8418/8430/8430 contains a suite of cross compilers and other tools, as well as the libraries and headers that are necessary to compile applications for the UC-8410/8416/8418/8430. The host environment must be running Linux to install the UC-8410/8416/8418/8430/8430 GNU Tool Chain. We have confirmed that the following Linux distributions can be used to install the tool chain:

Redhat 7.3/8.0/9.0, Fefora core 1/2/3/4/5, Debian 4.0 32 bits platform.

The Tool Chain will need about 836 MB of hard disk space on your PC. The UC-8410/8416/8418/8430/8430 Tool Chain is located on the UC-8410/8416/8418/8430/8430 CD. To install the Tool Chain, insert the CD into your PC and then issue the following commands:

**With v1.x firmware:**

```
#mount /dev/cdrom /mnt/cdrom
#sh /mnt/cdrom/tool-chain/linux/ arm-linux_2.3_Build_YMMDDHH.sh
```

**With v2.x firmware and arm-linux\_3.0\_Build\_YMMDDHH.sh**

```
#mount /dev/cdrom /mnt/cdrom
#sh /mnt/cdrom/tool-chain/linux/ arm-linux_3.0_Build_YMMDDHH.sh
```

Wait for a few minutes while the Tool Chain is installed automatically on your Linux PC. Once the host environment has been installed, add the directory /opt/montavista/pro/devkit/arm/xscale\_be/bin/ to your path and the directory /opt/montavista/pro/devkit/arm/xscale\_be/man/ to your manual path. You can do this temporarily for the current login session by issuing the following commands:

**For toolchain v2.x:**

```
#export PATH="/usr/local/arm-linux/bin:$PATH"
#export MANPATH="/usr/local/arm-linux/man:$MANPATH"
```

For toolchain v3.x:

```
#export PATH="/usr/local/arm-linux-4.4.2/bin:$PATH"
#export MANPATH="/usr/local/arm-linux-4.4.2/man:$MANPATH"
```

Alternatively, you can add the same commands to **\$HOME/.bash\_profile** to cause it to take effect for all login sessions initiated by this user.

## Obtaining help

Use the Linux **man** utility to obtain help on many of the utilities provided by the tool chain. For example to get help on the **arm-linux-gcc** compiler, issue the command:

```
#man arm-linux-gcc
```

## Cross Compiling Applications and Libraries

To compile a simple C application, just use the cross compiler instead of the regular compiler:

```
#xscale-linux-gcc -o example -Wall -g -O2 example.c
#xscale-linux-strip -s example
#xscale-linux-gcc -ggdb -o example-debug example.c
```

## Tools Available in the Host Environment

Most of the cross compiler tools are the same as their native compiler counterparts, but with an additional prefix that specifies the target system. In the case of x86 environments, the prefix is **i386-linux-** and in the case of the UC-8410/8416/8418/8430/8430 XScale boards, it is **xscale-linux-**.

For example, the native C compiler is **gcc** and the cross C compiler for XScale in the UC-8410/8416/8418/8430/8430 is **xscale-linux-gcc**.

The following cross compiler tools are provided:

ar	Manages archives (static libraries)
as	Assembler
c++, g++	C++ compiler
cpp	C preprocessor
gcc	C compiler
gdb	Debugger
ld	Linker
nm	Lists symbols from object files
objcopy	Copies and translates object files
objdump	Displays information about object files
ranlib	Generates indexes to archives (static libraries)
readelf	Displays information about ELF files
size	Lists object file section sizes
strings	Prints strings of printable characters from files (usually object files)
strip	Removes symbols and sections from object files (usually debugging information)

## Debugging with GDB

First use the option **-ggdb** to compile the program. Use the following steps:

1. To debug a program called **hello-debug** on the target, use the command:
 

```
#gdbserver 192.168.4.142:2000 hello-debug
```

This is where 2000 is the network port number on which the server waits for a connection from the client. This can be any available port number on the target. Following this are the name of the program to be debugged (hello-debug), plus that program's arguments. Output similar to the following will be sent to the console:

```
Process hello-debug created; pid=38
```

2. Use the following command on the host to change to the directory that contains hello-debug:  
`cd /my_work_directory/myfilesystem/testprograms`
3. Enter the following command:  
`#ddd --debugger xscale-linux-gdb hello-debug &`
4. Enter the following command at the GDB, DDD command prompt:  
`Target remote 192.168.4.99:2000`

The command produces another line of output on the target console, similar to the following:

```
Remote debugging using 192.168.4.99:2000
```

192.168.4.99 is the machine's IP address, and 2000 is the port number. You can now begin debugging in the host environment using the interface provided by DDD.

5. Set a breakpoint on main by double clicking, or entering **b main** on the command line.
6. Click the **cont** button

## Device API

The UC-8410/8416/8418/8430/8430 supports control devices with the **ioctl** system API. You will need to include **<moxadevice.h>**, and use the following **ioctl** function.

```
int ioctl(int d, int request,...);
Input:  int d      - open device node return file handle
        int request - argument in or out
```

Use the desktop Linux's man page for detailed documentation:

```
#man ioctl
```

## RTC (Real Time Clock)

The device node is located at **/dev/rtc**. The UC-8410/8416/8418/8430/8430 supports Linux standard simple RTC control. You must include **<linux/rtc.h>**.

1. Function: RTC\_RD\_TIME

```
int ioctl(fd, RTC_RD_TIME, struct rtc_time *time);
```

Description: read time information from the RTC. It will return the value on argument 3.

2. Function: RTC\_SET\_TIME

```
int ioctl(fd, RTC_SET_TIME, struct rtc_time *time);
```

Description: set RTC time. Argument 3 will be passed to the RTC.



## Buzzer

The device node is located at `/dev/console`. The UC-8410/8416/8418/8430/8430 supports Linux standard buzzer control, with the UC-8410/8416/8418/8430's buzzer running at a fixed frequency of 100 Hz. You must include `<sys/kd.h>`.

1. Function: KDMKTONE

```
ioctl(fd, KDMKTONE, unsigned int arg);
```

Description: The buzzer's behavior is determined by the argument `arg`. The "high word" part of `arg` gives the length of time the buzzer will sound, and the "low word" part gives the frequency.

The buzzer's on/off behavior is controlled by software. If you call the "ioctl" function, you MUST set the frequency to 100 Hz. If you use a different frequency, the system could crash.

## WDT (Watch Dog Timer)

1. **Introduction**

The WDT works like a watch dog function. You can enable it or disable it. When the user enables WDT but the application does not acknowledge it, the system will reboot. You can set the ack time from a minimum of 50 msec to a maximum of 60 seconds.

2. **How the WDT works**

The sWatchDog is enabled when the system boots up. The kernel will auto ack it. The user application can also enable ack. When the user does not ack, it will let the system reboot.

Kernel boot

```
....
....
```

User application running and enable user ack

```
....
....
```

3. **The user API**

The user application must use `include <moxadef.h>`, and `link libmoxalib.a`. A makefile example is shown below:

```
all:
    xscale-linux-gcc -o xxxx xxxx.c -lmoxalib
```

```
int swtd_open(void)
```

### Description

If you would like to activate Watchdog for the AP, you must call this function.

### Input

None

### Output

The return value is file handle. If there is an error, it will return a negative value.

You can get the error using the function `errno()`.

```
int swtd_enable(int fd, unsigned long time)
```

### Description

Enable the application sWatchDog. You must do an ack after this process.

### Input

int fd - the file handle, from the `swtd_open()` return value.

unsigned long time - The time you wish to ack sWatchDog periodically. You must ack the sWatchDog before timeout. If you do not ack, the system will reboot automatically. The minimum time is 50 msec, and the maximum time is 60 seconds. The time unit is msec.

**Output**

If you receive 0 (zero), it means the function is working. If you receive any other number, then there is something wrong with this function.

```
int swtd_disable(int fd)
```

**Description:**

Call this function if you would like the AP to stop using the Watchdog.

**Input :**

int fd - the file handle from swtd\_open() return value.

**Output:**

If you receive 0 (zero), it means the function is working. If you receive any other number, then there is something wrong with this function.

```
int swtd_get(int fd, int *mode, unsigned long *time)
```

**Description:**

Get current setting values.

mode -

1 for user application enable sWatchDog: need to do ack.

0 for user application disable sWatchdog: does not need to do ack.

time - The time period to ack sWatchDog.

**Input:**

int fd - the file handle from swtd\_open() return value.

int \*mode - the function will return the status: enable or disable.

unsigned long \*time - the function will return the current time period.

**Output:**

If you receive 0 (zero), it means the function is working. If you receive any other number, then there is something wrong with this function.

```
int swtd_ack(int fd)
```

**Description:**

Acknowledge sWatchDog. When the user application enable sWatchDog, it need to call this function periodically with user predefined time in the application program.

**Input:**

int fd - the file handle from swtd\_open() return value.

**Output:**

If you receive 0 (zero), it means the function is working. If you receive any other number, then there is something wrong with this function.

```
int swtd_close(int fd)
```

**Description:**

Close the file handle.

**Input:**

int fd - the file handle from swtd\_open() return value.

**Output:**

If you receive 0 (zero), it means the function is working. If you receive any other number, then there is something wrong with this function.

**4. Special Note**

When you “kill the application with -9” or “kill without option” or “Ctrl+c” the kernel will change to auto ack the sWatchDog.

When your application enables the sWatchDog and does not ack, your application may have a logical error, or your application has made a core dump. The kernel will not change to auto ack. This can cause a serious problem, causing your system to reboot again and again.

## 5. User application example

### Example 1:

```
#include <stdio.h>
#include <stdlib.h>
#include <string.h>
#include <moxadevice.h>
int main(int argc, char *argv[])
{
    int fd;
    fd = swtd_open();
    if ( fd < 0 ) {
        printf("Open sWatchDog device fail !\n");
        exit(1);
    }
    swtd_enable(fd, 5000); // enable it and set it 5 seconds
    while ( 1 ) {
        // do user application want to do
        ....
        ...
        swtd_ack(fd);
        ....
        ...
    }
    swtd_close(fd);
    exit(0);
}
```

The makefile is shown below:

```
all:
    xscale-linux-gcc -o xxxx xxxx.c -lmoxalib
```

### Example 2:

```
#include <stdio.h>
#include <stdlib.h>
#include <signal.h>
#include <string.h>
#include <sys/stat.h>
#include <sys/ioctl.h>
#include <sys/select.h>
#include <sys/time.h>
#include <moxadevice.h>
static void mydelay(unsigned long msec)
{
    struct timeval time;
    time.tv_sec = msec / 1000;
    time.tv_usec = (msec % 1000) * 1000;
    select(1, NULL, NULL, NULL, &time);
}
static int swtdfd;
static int stopflag=0;
```

```

static void stop_swatcdog()
{
    stopflag = 1;
}
static void do_swatcdog(void)
{
    swtd_enable(swtdfd, 500);
    while ( stopflag == 0 ) {
        mydelay(250);
        swtd_ack(swtdfd);
    }
    swtd_disable(swtdfd);
}
int main(int argc, char *argv[])
{
    pid_t      sonpid;
    signal(SIGUSR1, stop_swatcdog);
    swtdfd = swtd_open();
    if ( swtdfd < 0 ) {
        printf("Open sWatchDog device fail !\n");
        exit(1);
    }
    if ( (sonpid=fork()) == 0 )
        do_swatcdog();
    // do user application main function
    ....
    ....
    ....
    // end user application
    kill(sonpid, SIGUSR1);
    swtd_close(swtdfd);
    exit(1);
}

```

The makefile is shown below:

```

all:
    xscale-linux-gcc -o xxxx xxxx.c -lmoxalib

```

## Digital I/O

Digital Output channels can be set to high or low. The channels are controlled by the function call **set\_dout\_state( )**. The Digital Input channels can be used to detect the state change of the digital input signal. The DI channels can also be used to detect whether or not the state of a digital signal changes during a fixed period of time. This can be done with the function call **set\_din\_event( )**. Moxa provides 5 function calls to handle digital I/O state changes and event handling.

### Application Programming Interface

Return error code definitions:

```

#define DIO_ERROR_PORT -1 // no such port
#define DIO_ERROR_MODE -2 // no such mode or state
#define DIO_ERROR_CONTROL -3 // open or ioctl fail

```

```
#define DIO_ERROR_DURATION -4 // The value of duration is not 0 or not in the range,
40 <= duration <= 3600000 milliseconds (1 hour)
#define DIO_ERROR_DURATION_20MS -5 // The value of duration must be a multiple of 20
ms
#define DIO_OK 0
```

The definition of DIN and DOUT:

```
#define DIO_HIGH 1
#define DIO_LOW 0
int set_dout_state(int doport, int state)
```

Description: To set the DOUT port to high or low state.

Input: int doport - which DOUT port you want to set. Port starts from 0 to 3.

int state - to set high or low state; DIO\_HIGH (1) for high, DIO\_LOW (0) for low.

Output: none.

Return: reference the error code.

```
int get_din_state(int diport, int *state)
```

Description: To get the DIN port state.

Input: int diport - get the current state of which DIN port. Port numbering is from 0 to 3.

int \*state - save the current state.

Output: state - DIO\_HIGH (1) for high, DIO\_LOW (0) for low.

Return: reference the error code.

```
int get_dout_state(int doport, int *state)
```

Description: To get the DOUT port state.

Input: int doport - get the current state of which DOUT port.

int \*state - save the current state.

Output: state - DIO\_HIGH (1) for high, DIO\_LOW (0) for low.

Return: reference the error code.

```
int set_din_event(int diport, void (*func)(int diport), int mode, long int duration)
```

Description: Set the event for DIN when the state is changed from high to low or from low to high.

Input: int diport - the port that will be used to detect the DIN event.

Port numbering is from 0 to 3.

void (\*func)(int diport) - Not NULL

> Returns the call back function. When the event occurs, the call back function will be invoked.

NULL > Clears this event

```
int mode DIN_EVENT_HIGH_TO_LOW
```

(1): from high to low

DIN\_EVENT\_LOW\_TO\_HIGH

(0): from low to high

DIN\_EVENT\_CLEAR

(-1): clear this event

unsigned long duration - 0: detect the din event > DIN\_EVENT\_HIGH\_TO\_LOW or

DIN\_EVENT\_LOW\_TO\_HIGH > without duration

- Not 0

> detect the din event

DIN\_EVENT\_HIGH\_TO\_LOW or

DIN\_EVENT\_LOW\_TO\_HIGH with duration. The value of "duration" must be a multiple of 20 milliseconds.

The range of "duration" is 0, or 40 <= duration <= 3600000 milliseconds. The error of the measurement is 24 ms. For example, if the DIN duration is 200 ms, this event will be generated when the DIN pin stays in the same state for a time between 176 ms and 200 ms. Output: none.

Return: reference the error code.

```
int get_din_event(int diport, int *mode, long int *duration)
```

Description: To retrieve the DIN event configuration, including mode

(DIN\_EVENT\_HIGH\_TO\_LOW or DIN\_EVENT\_LOW\_TO\_HIGH), and the value of "duration."

Input: **int diport** - which DIN port you want to retrieve.

- The port whose din event setting we wish to retrieve

**int \*mode** - save which event is set.

**unsigned long \*duration** - the duration of the DIN port is kept in high or low state.

- return to the current duration value of diport

Output: **mode** DIN\_EVENT\_HIGH\_TO\_LOW

(1): from high to low

DIN\_EVENT\_LOW\_TO\_HIGH(0): from low to high

DIN\_EVENT\_CLEAR(-1): clear this event

**duration** The value of duration should be 0 or 40 <= duration

<= 3600000 milliseconds.

Return: reference the error code.

## Special Note

Do not forget to link to the library **libmoxalib.a** for DI/DO programming, and also include the header file **moxadevice.h**. The DI/DO library only can be used by one program at a time.

## Examples

### Example 1

File Name: tdio.c

Description: The program indicates to connect DO1 to DI1, change the digital output state to high or low by manual input, and then detect and count the state changed events from DI1.

```
#include <stdio.h>
#include <stdlib.h>
#include <moxadevice.h>
#include <fcntl.h>
#ifdef DEBUG
#define dbg_printf(x...) printf(x)
#else
#define dbg_printf(x...)
#endif
#define MIN_DURATION 40
static char *DataString[2]={"Low ", "High "};
static void hightolowevent(int diport)
{
printf("\nDIN port %d high to low.\n", diport);
}
static void lowtohighevent(int diport)
{
printf("\nDIN port %d low to high.\n", diport);
}
int main(int argc, char * argv[])
{
int i, j, state, retval;
unsigned long duration;
while( 1 ) {
```

```

printf("\nSelect a number of menu, other key to exit. \n\
1. set high to low event \n\
2. get now data. \n\
3. set low to high event \n\
4. clear event \n\
5. set high data. \n\
6. set low data. \n\
7. quit \n\
8. show event and duration \n\
Choose : ");
retval =0;
scanf("%d", &i);
if ( i == 1 ) { // set high to low event
printf("Please keyin the DIN number : ");
scanf("%d", &i);
printf("Please input the DIN duration, this minimun value must be over %d : ",
MIN_DURATION);
scanf("%lu", &duration);
retval=set_din_event(i, hightolowevent, DIN_EVENT_HIGH_TO_LOW, duration);
} else if ( i == 2 ) { // get now data
printf("DIN data : ");
for ( j=0; j<4; j++ ) {
get_din_state(j, &state);
printf("%s", DataString[state]);
}
printf("\n");
printf("DOUT data : ");
for ( j=0; j<MAX_DOUT_PORT; j++ ) {
get_dout_state(j, &state);
printf("%s", DataString[state]);
}
printf("\n");
} else if ( i == 3 ) { // set low to high event
printf("Please keyin the DIN number : ");
scanf("%d", &i);
printf("Please input the DIN duration, this minimun value must be over %d :",
MIN_DURATION);
scanf("%lu", &duration);
retval = set_din_event(i, lowtohighevent, DIN_EVENT_LOW_TO_HIGH, duration);
} else if ( i == 4 ) { // clear event
printf("Please keyin the DIN number : ");
scanf("%d", &i);
retval=set_din_event(i, NULL, DIN_EVENT_CLEAR, 0);
} else if ( i == 5 ) { // set high data
printf("Please keyin the DOUT number : ");
scanf("%d", &i);
retval=set_dout_state(i, 1);
} else if ( i == 6 ) { // set low data
printf("Please keyin the DOUT number : ");
scanf("%d", &i);
retval=set_dout_state(i, 0);
} else if ( i == 7 ) { // quit
break;
} else if ( i == 8 ) { // show event and duration
printf("Event:\n");

```

```

for ( j=0; j<MAX_DOUT_PORT; j++ ) {
retval=get_din_event(j, &i, &duration);
switch ( i ) {
case DIN_EVENT_HIGH_TO_LOW :
printf("(htl,%lu)", duration);
break;
case DIN_EVENT_LOW_TO_HIGH :
printf("(lth,%lu)", duration);
break;
case DIN_EVENT_CLEAR :
printf("(clr,%lu)", duration);
break;
default :
printf("err " );
break;
}
}
printf("\n");
} else {
printf("Select error, please select again !\n");
}
switch(retval) {
case DIO_ERROR_PORT:
printf("DIO error port\n");
break;
case DIO_ERROR_MODE:
printf("DIO error mode\n");
break;
case DIO_ERROR_CONTROL:
printf("DIO error control\n");
break;
case DIO_ERROR_DURATION:
printf("DIO error duratoin\n");
case DIO_ERROR_DURATION_20MS:
printf("DIO error! The duratoin is not a multiple of 20 ms\n");
break;
}
}
return 0;
}

```

## DIO Program Make File Example

```

FNAME=tdio
CC=xscale-linux-gcc
STRIP=xscale-linux-strip
release:
$(CC) -o $(FNAME) $(FNAME).c -lmoxalib -lpthread
$(STRIP) -s $(FNAME)
debug:
$(CC) -DDEBUG -o $(FNAME)-dbg $(FNAME).cxx -lmoxalib -lpthread
clean:
/bin/rm -f $(FNAME) $(FNAME)-dbg *.o

```



**Note: For the UC-8418, 8 additional digital input channels and 8 additional digital output channels are provided. The port numbers for these go from 4 to 11.**

## UART

The normal tty device node is located at `/dev/ttyM0 ... ttyM7`, and the modem tty device node is located at `/dev/cum0 ... cum7`.

The UC-8410/8416/8418/8430/8430 supports Linux standard termios control. The Moxa UART Device API allows you to configure ttyM0 to ttyM7 as RS-232, RS-422, 4-wire RS-485, or 2-wire RS-485. The UC-8410/8416/8418/8430/8430 supports RS-232, RS-422, 2-wire RS-485, and 4-wire RS485.

You must include `<moxadvice.h>`.

```
#define RS232_MODE          0
#define RS485_2WIRE_MODE   1
#define RS422_MODE         2
#define RS485_4WIRE_MODE   3
```

1. Function: MOXA\_SET\_OP\_MODE

```
int ioctl(fd, MOXA_SET_OP_MODE, &mode)
```

### Description

Set the interface mode. Argument 3 mode will pass to the UART device driver and change it.

2. Function: MOXA\_GET\_OP\_MODE

```
int ioctl(fd, MOXA_GET_OP_MODE, &mode)
```

### Description

Get the interface mode. Argument 3 mode will return the interface mode.

There are two Moxa private ioctl commands for setting up special baudrates.

Function: MOXA\_SET\_SPECIAL\_BAUD\_RATE

Function: MOXA\_GET\_SPECIAL\_BAUD\_RATE

If you use this ioctl to set a special baudrate, the termios cflag will be B4000000, in which case the B4000000 definition will be different. If the baudrate you get from termios (or from calling tcgetattr()) is B4000000, you must call ioctl with MOXA\_GET\_SPECIAL\_BAUD\_RATE to get the actual baudrate.

## Setinterface

The Serial Port Expansion Module has 8 serial ports, labeled ttyM0 to ttyM7. The ports support RS-232, RS-422, and RS-485 2-wire and 4-wire operation modes with baudrate settings up to 921600 bps.

The default operation mode is set to RS-232. You can use the **setinterface** command to change the serial port operation mode.

Usage: setinterface device-node [interface-no]

device-node -- /dev/ttyMn; n = 0,1,2,...

interface-no -- As shown in the following table:

interface-no	Operation Mode
None	Display current setting
0	RS-232
1	RS-485 2-wire

2	RS-422
3	RS-485 4-wire

The following example sets /dev/ttyM0 to RS-422 mode

```
root@moxa:/# setinterface /dev/ttyM0 2
root@moxa:~# setinterface /dev/ttyM0
Now setting is RS422 interface.
root@moxa:~#
```

## Example for setting the baudrate

```
#include <moxadevice.h>
#include <termios.h>
struct termios term;
int fd, speed;
fd = open("/dev/ttyM0", O_RDWR);
tcgetattr(fd, &term);
term.c_cflag &= ~(CBAUD | CBAUDEX);
term.c_cflag |= B4000000;
tcsetattr(fd, TCSANOW, &term);
speed = 500000;
ioctl(fd, MOXA_SET_SPECIAL_BAUD_RATE, &speed);
```

## Example for getting the baudrate

```
#include <moxadevice.h>
#include <termios.h>
struct termios term;
int fd, speed;
fd = open("/dev/ttyM0", O_RDWR);
tcgetattr(fd, &term);
if ( (term.c_cflag & (CBAUD|CBAUDEX)) != B4000000 )
{ // follow the standard termios baud rate define } else
{ ioctl(fd, MOXA_GET_SPECIAL_BAUD_RATE, &speed); }
```

## Baudrate inaccuracy

Divisor = 921600/Target Baud Rate. (Only Integer part)  
 ENUM = 8 \* (921600/Target - Divisor) ( Round up or down)  
 Inaccuracy = (Target Baud Rate - 921600/(Divisor + (ENUM/8))) / Target Baud Rate \* 100%  
 E.g.,  
 To calculate 500000 bps  
 Divisor = 1, ENUM = 7,  
 Inaccuracy = 1.7%

**NOTE: The Inaccuracy should less than 2% for the device to work reliably.**

## Special Note

1. If the target baudrate is not a special baudrate (e.g., 50, 75, 110, 134, 150, 200, 300, 600, 1200, 1800, 2400, 4800, 9600, 19200, 38400, 57600, 115200, 230400, 460800, 921600), the termios cflag will be set to the same flag.

- If you use stty to get the serial information, you will get a speed equal to 0.

## SRAM

### 1. Introduction

The UC-8410/8416/8418/8430/8430 provides 256 KB of embedded SRAM. As there is a system battery inside the computer, the SRAM can work and be used to keep data even when the system is crashed. This means that the data stored on the SRAM will not be lost after the UC-8410/8416/8418/8430/8430 is powered off.

### 2. How the SRAM works

The SRAM device can be programmed through the file `/dev/sram`. This means that you can read from or write to `/dev/sram` to store data on the embedded SRAM. The following example illustrates how to do this:

```

/*****
History :
  Versoin      Author      Date      Comment
  1.0          Jared Wu.   09-11-2008 Write a pattern to SRAM.
*****/
#include <sys/types.h>
#include <sys/stat.h>
#include <stdio.h>
#include <stdlib.h>
#include <string.h>
#include <fcntl.h>
#include <linux/kd.h>
#define SRAM_SIZE0x00040000 // 256 Kbytes
static char sram_buf1[SRAM_SIZE], sram_buf2[SRAM_SIZE];
int main(int argc, char * argv[])
{
    int    fd, len;
    unsigned long  ms=0;
    char pattern='9';
    if ( argc > 2 ) {
        printf("Usage: %s [pattern]\n");
        exit(0);
    }
    if ( argc == 2 ) {
        pattern=argv[1][0];
        printf("pattern:%c\n", pattern);
    }
    fd = open("/dev/sram", O_RDWR);
    if( fd < 0 ) {
        printf("Open /dev/sram fail");
        exit(0);
    }
    // Write the sram with patern
    memset(sram_buf1, pattern, sizeof(sram_buf1));
    len=write(fd, sram_buf1, sizeof(sram_buf1));
    if( len < 0 ) {
        printf("Write /dev/sram fail");
        exit(0);
    }
    printf("The content is written\n");
    close(fd);

```

```

}
/*****
History :
  Versoin      Author      Date      Comment
  1.0         Jared Wu.    09-11-2008  Read from the SRAM and compare with some pattern.
*****/
#include <sys/types.h>
#include <sys/stat.h>
#include <stdio.h>
#include <stdlib.h>
#include <string.h>
#include <fcntl.h>
#include <linux/kd.h>
#define SRAM_SIZE0x00040000 // 256 Kbytes
static char sram_buf1[SRAM_SIZE], sram_buf2[SRAM_SIZE];
int main(int argc, char * argv[])
{
    int    fd, len;
    unsigned long  ms=0;
    char pattern='9';
    if ( argc > 2 ) {
        printf("Usage: %s [pattern]\n");
        exit(0);
    }
    if ( argc == 2 ) {
        pattern=argv[1][0];
        printf("pattern:%c\n", pattern);
    }
    fd = open("/dev/sram", O_RDWR);
    if( fd < 0 ) {
        printf("Open /dev/sram fail");
        exit(0);
    }
    // Write the sram with pattern
    memset(sram_buf1, pattern, sizeof(sram_buf1));
    // Read from sram and compare with pattern
    len=read(fd, sram_buf2, sizeof(sram_buf2));
    if( len < 0 ) {
        printf("Read from /dev/sram fail\n");
        exit(0);
    }
    if ( memcmp(sram_buf1, sram_buf2, SRAM_SIZE) != 0 ) {
        printf("Memory compared fail\n");
        exit(0);
    }
    printf("The content is identical\n");
    close(fd);
}

```

## Make File Example

The following Makefile file sample code is copied from the Hello example on the UC-8410/8416/8418/8430's CD-ROM.

```
CC = xscale-linux-gcc
```

```

CPP = xscale-linux-gcc
SOURCES = hello.c
OBJS = $(SOURCES:.c=.o)
all: hello
hello: $(OBJS)
$(CC) -o $@ $^ $(LDFLAGS) $(LIBS)
clean:
rm -f $(OBJS) hello core *.gdb

```

## Moxa CAN Programming Guide

### Introduction

CAN is a broadcast serial bus standard for connecting electronic control units (ECUs).

Each node is able to send and receive messages, but not simultaneously: a message (consisting primarily of an ID—usually chosen to identify the message-type/sender—and up to eight message bytes) is transmitted serially onto the bus, one bit after another. This signal-pattern codes the message (in NRZ) and is sensed by all nodes.

Moxa embedded computers provide the CAN bus interface for industrial CAN communication. Users can use the file control interface to read, write or control the CAN interface as a file for easy CAN programming.

### Programming Guide

The CAN data format looks like this:

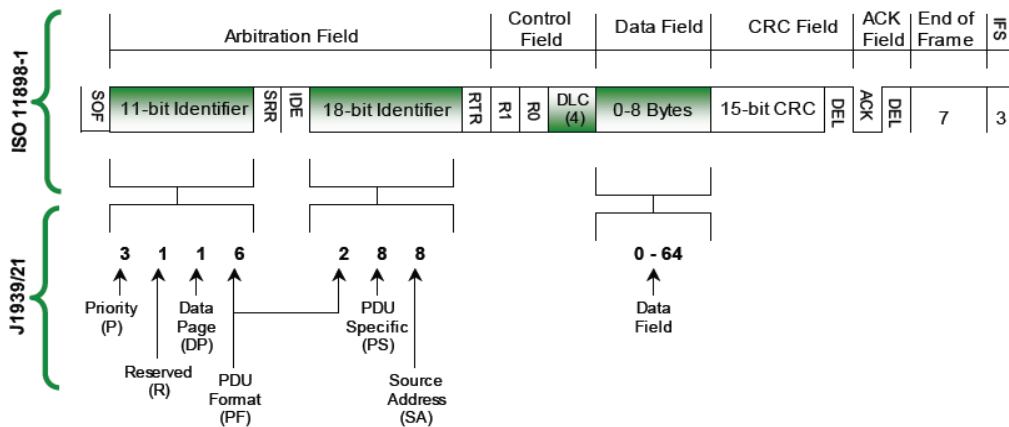

Define the structure for CAN programming as follows:

```

moxacan_ioctl.h
#ifndef _MOXACAN_IOCTL_H
#define _MOXACAN_IOCTL_H
#ifndef BIT
#define BIT(x) (1<<(x))
#endif // BIT
#define MAX_CAN_DATA_LENGTH 8
typedef union __attribute__((packed)) can_data_union {
    unsigned char array[MAX_CAN_DATA_LENGTH];
    struct byte_struct {
        unsigned char byte1;
        unsigned char byte2;
    };
};

```

```

        unsigned char  byte3;
        unsigned char  byte4;
        unsigned char  byte5;
        unsigned char  byte6;
        unsigned char  byte7;
        unsigned char  byte8;
    } byte;
} can_data_u;
typedef struct user_frame_struct {
    int          id;
    int          info;    // RTR & extend ID flag
#define USER_RTR          BIT(0)
#define USER_EXTEND_ID BIT(1)
    int          data_length;
    can_data_u   data;
} user_frame_t;
// ioctl command code
#define MOXACAN_IOCTL_SET_BAUD_RATE 0x100
#define MOXACAN_IOCTL_GET_BAUD_RATE 0x101
#endif // _MOXACAN_IOCTL_H

```

Then we can include this header for CAN programming

We can open `/dev/can[n]` to use the CAN device. Then `read()`, `write()` or `ioctl()` the device files. If you complete the using, you should `close()` this file to release this device.

```

#include <stdio.h>
#include <stdlib.h>
#include <fcntl.h>
#include <string.h>
#include "moxacan_ioctl.h"
#define PORT1_NAME "/dev/can0"
#define PORT2_NAME "/dev/can1"
int main(int argc, char *argv[])
{
    int          fd1, fd2, i, baudrate;
    user_frame_t txframe, rxframe;
    fd1 = open(PORT1_NAME, O_RDWR);
    if ( fd1 < 0 ) {
        printf("Open %s fail !\n", PORT1_NAME);
        return -1;
    }
    fd2 = open(PORT2_NAME, O_RDWR);
    if ( fd2 < 0 ) {
        printf("Open %s fail !\n", PORT2_NAME);
        return -1;
    }
    baudrate = 100000;
    ioctl(fd1, MOXACAN_IOCTL_SET_BAUD_RATE, &baudrate);
    ioctl(fd2, MOXACAN_IOCTL_SET_BAUD_RATE, &baudrate);
    memset(&txframe, 0, sizeof(txframe));
    memset(&rxframe, 0, sizeof(rxframe));
    txframe.id = 12;
    txframe.data_length = MAX_CAN_DATA_LENGTH;
    txframe.info |= USER_EXTEND_ID;
    for ( i=0; i<MAX_CAN_DATA_LENGTH; i++ )
        txframe.data.array[i] = 0x30+i;
}

```

```

    i = write(fd1, &txframe, sizeof(txframe));
    printf("Write port1 data return = %d\n", i);
    printf("Write data contexts are following :\n");
    for ( i=0; i<MAX_CAN_DATA_LENGTH; i++ )
        printf("%c", txframe.data.array[i]);
    printf("\n");
    usleep(1);
    i = read(fd2, &rxframe, sizeof(rxframe));
    printf("Read port2 data return = %d\n", i);
    printf("Receive frame id = %d, length = %d\n", rxframe.id, rxframe.data_length);
    printf("Receive data contexts are following :\n");
    for ( i=0; i<MAX_CAN_DATA_LENGTH; i++ )
        printf("%c", rxframe.data.array[i]);
    printf("\n");
    close(fd1);
    close(fd2);
    return 0;
}

```

```

Makefile
CROSS_COMPILE=xscale-linux-
CC=$(CROSS_COMPILE)gcc
LD=$(CROSS_COMPILE)ld
STRIP=$(CROSS_COMPILE)strip
#STRIP=$(CROSS_COMPILE)strip -s
TARGET=tcan
TARGET1=canttrw
all:    debug release
debug: $(TARGET).c $(TARGET1).c moxacan_ioctl.h
        $(CC) -ggdb -o $(TARGET)-debug $(TARGET).c
        $(CC) -ggdb -o $(TARGET1)-debug $(TARGET1).c
release: $(TARGET).c $(TARGET1).c moxacan_ioctl.h
        $(CC) -o $(TARGET)-release $(TARGET).c
        $(CC) -o $(TARGET1)-release $(TARGET1).c
        $(STRIP) $(TARGET)-release $(TARGET1)-release
clean:
        rm -f *.o $(TARGET)-debug $(TARGET)-release $(TARGET1)-debug $(TARGET1)-release

```

**Note: Only UC-8418-LX support CAN port communication.**

## Software Lock

"Software Lock" is an innovative technology developed by the Moxa engineering team, and can be used by a system integrator or developer to protect applications from being copied. An application is compiled into a binary format bound to the embedded computer, and the operating system that the application runs on. As long as it is obtained from the computer, it can be installed on the same hardware and under the same operating system, resulting in a loss of the add-on value created by the developer.

Users can deploy this data encryption method to develop the software for the applications. The binary file associated with each of your applications needs to undergo an additional encryption process after you have developed it. The process requires you to install an encryption key in the target computer.

1. Choose an encryption key (e.g., "ABigKey") and install it in the target computer by a pre-utility program called 'setkey'.

```
#setkey ABigKey
```

**NOTE: Use the following command to clear the encryption key on the target computer.**

```
#setkey ""
```

2. Develop and compile your program on the development PC.
3. On the development PC, run the utility program 'binencryptor' to encrypt your program with an encryption key.

```
#binencryptor yourProgram ABigKey
```

4. Upload the encrypted program file to the target computer by FTP or NFS and test the program.

The encryption key is a computer-wise key. This means that the computer has only one key installed. Running the program 'setkey' multiple times overrides the existing key.

To prove the effectiveness of this software protection mechanism, prepare a target computer on which an encryption key has not been installed, or install a key different from that used to encrypt your program. In either case, the encrypted program fails immediately.

This mechanism also allows computers with an encryption key installed to bypass programs that are not encrypted. This is handy in the development phase since you can develop your programs and test them cleanly on the target computer.

## Qt-embedded

The UC-8430 offers the QT library which helps programmers design the UI framework. See the following for details.

### QT programming development flow chart.

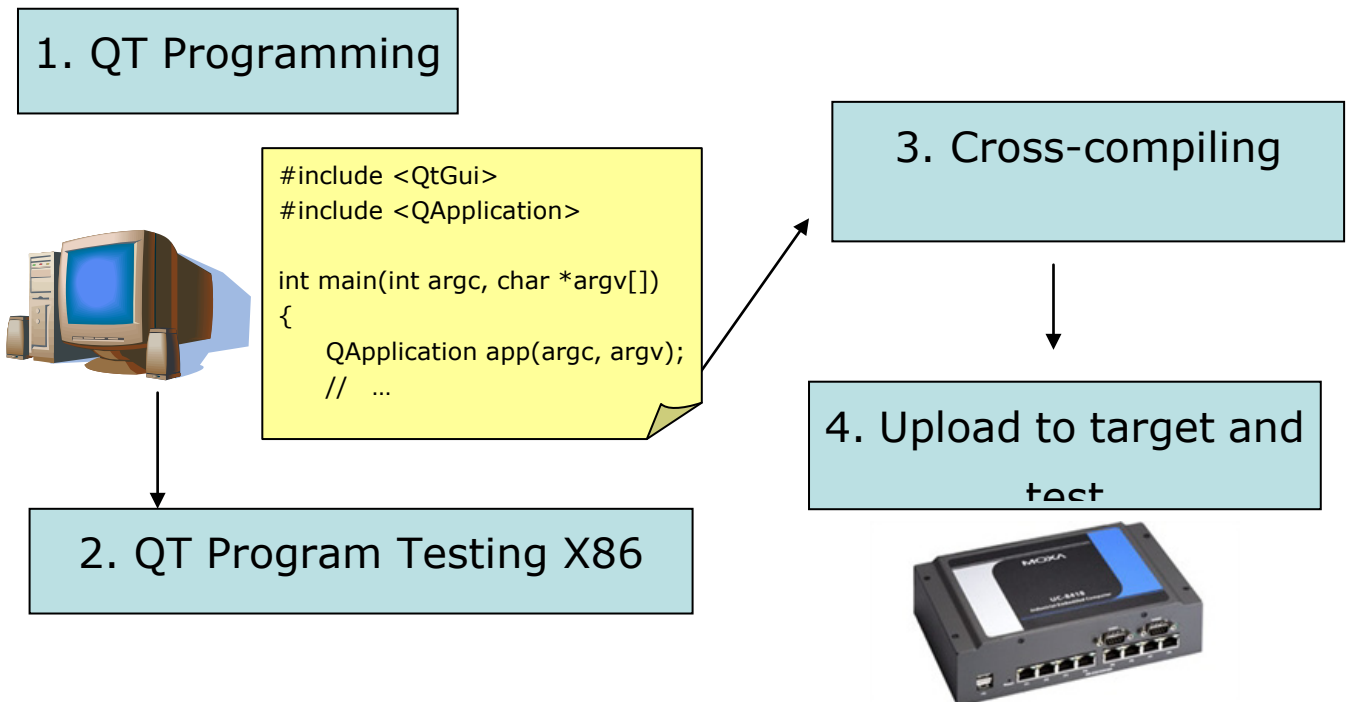

Write the QT program to run the in the target environment. A basic QT program is shown below.

```
#include <QtGui>
#include <QApplication>
#include <QLabel>
```



```

int main(int argc, char *argv[])
{
    QApplication app(argc, argv);
    QLabel *label = new QLabel("<H1>hello <font color=red>QT</font></H1>");
    QWidget window;
    label->setWindowTitle("Hello");
    label->setAlignment(Qt::AlignCenter);
    label->resize(200,100);
    label->show();
    window.resize(320, 240);
    window.show();
    window.setWindowTitle(
        QApplication::translate("oplevel", "Top-level widget"));
    return app.exec();
}

```

## Compile and Test the QT Program on an X86 Machine

- **Install the QT developing package**  
apt-get install build-essential libqt4-dev libqt4-dev-tools qt4-designer
- **Compile the programs**
  1. Create the project file hello.pro  
qmake -project
  2. Create the Makefile  
qmake
  3. Compile  
**Make**
  4. Execute  
**./hello**

## Set up Qt development

The qt-libraries have been included in arm-linux\_2.3\_YMMDDHH.sh/arm-linux\_3.x\_YMMDDHH.sh. You can launch the auto-installed script to install the libraries. The setup the QTDIR and PATH for cross-compiling:

### For toolchain v2.x:

```

Debian:~# export QTDIR=/usr/local/arm-linux/lib/be/qt-lib
Debian:~# export PATH=$QTDIR/bin:$PATH

```

### For toolchain v3.x:

```

Debian:~# export QTDIR=/usr/local/arm-linux-4.4.2/lib/be/qt-lib
Debian:~# export PATH=$QTDIR/bin:$PATH

```

## Cross-compile the Qt application and run with Dual-display

### To enter the project folder:

```

Debian:~# cd hello

```

### To create the project file, hello.pro:

```

Debian:~# qmake -project

```

### To create the Makefile:

```

Debian:~# qmake

```

**To cross compile:**

```
Debian:~# make
```

## Upload the binary to target and run it with following command

Run the Qt application with assigned input and VGA output:

```
root@Moxa:/tmp# export QWS_MOUSE_PROTO=IntelliMouse:/dev/input/mouse0 ;  
root@Moxa:/tmp# ./hello -qws -geometry 1024x768 -display voyagerlib:/dev/fb0 &
```

You can also run the second Qt application on another VGA output:

```
root@Moxa:/tmp# export QWS_MOUSE_PROTO=IntelliMouse:/dev/input/mouse1 ;  
root@Moxa:/tmp# ./hello2 -qws -geometry 1024x768 -display voyagerlib:/dev/fb1 &
```

**NOTE** Refer to the Qt-embedded Web site, <http://qt.nokia.com/doc/4.6/index.html>, for more details on Qt programming ,

# A

## Firmware Upgrade Procedure

Moxa provides a boot loader utility for firmware upgrade or recovery. You will need the following items to use this utility.

1. The embedded computer that you would like to upgrade or recover.
2. A PC or a laptop computer.
3. A console port cable for connecting through HyperTerminal.
4. A cross-over Ethernet cable for upgrading the firmware through a TFTP server and LAN port.
5. The firmware for the embedded computer.

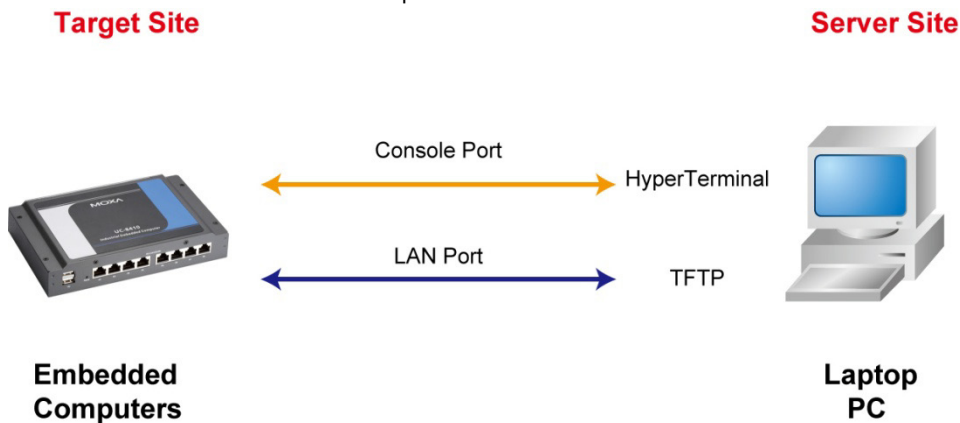

There are three steps in the recovery process.

- A. Configure HyperTerminal for the console port.**
- B. Download and installation of the TFTP program.**
- C. Download the firmware and upgrade through HyperTerminal.**

If you are familiar with Moxa embedded computers and the firmware upgrade procedure, you may skip to Step C. However, we suggest that you go through all three steps to ensure the firmware upgrades properly.

### A. Configure HyperTerminal for the Console Port.

1. Unscrew the cover on the back of the UC-8410 series embedded computer.
2. Connect the console port with a console port cable to your PC.

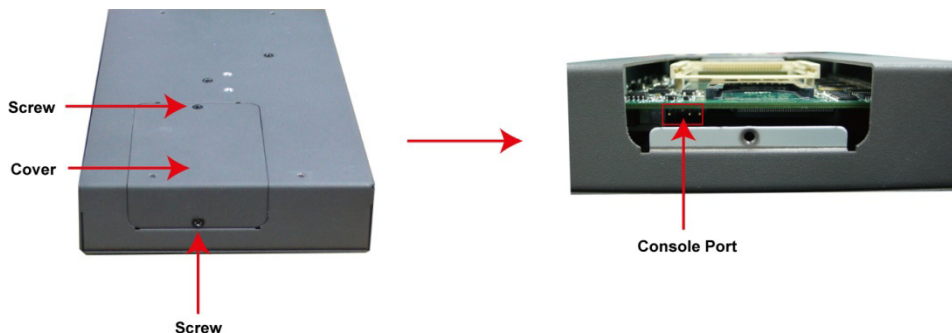

3. Connect your embedded computer to the power source. The power input is located on the rear panel.

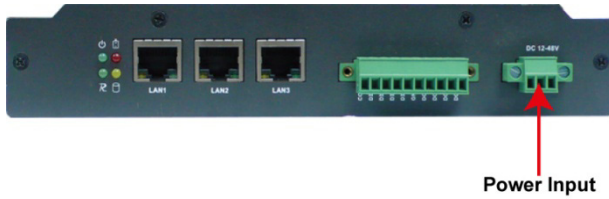

4. Launch a serial communication tool to access your embedded computer. We suggest that you use HyperTerminal, which is built into Windows XP. Click **Start → Programs → Accessories → Communications** and then select **HyperTerminal**.

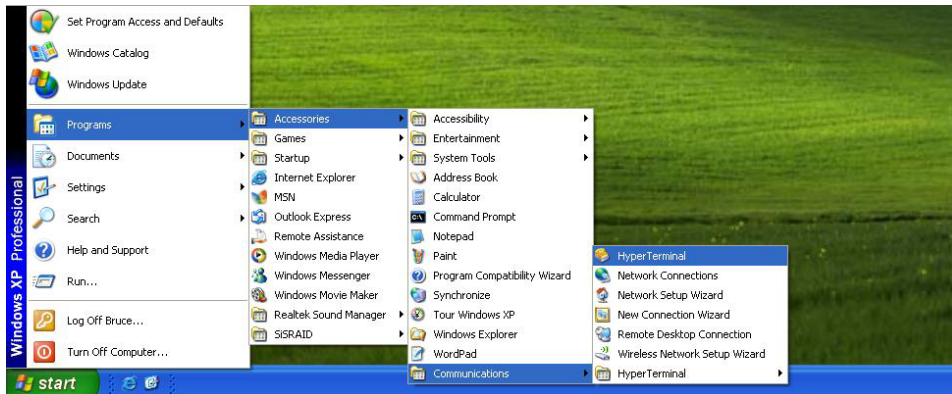

5. After HyperTerminal launches, enter UC-8410 or another name for the connection.

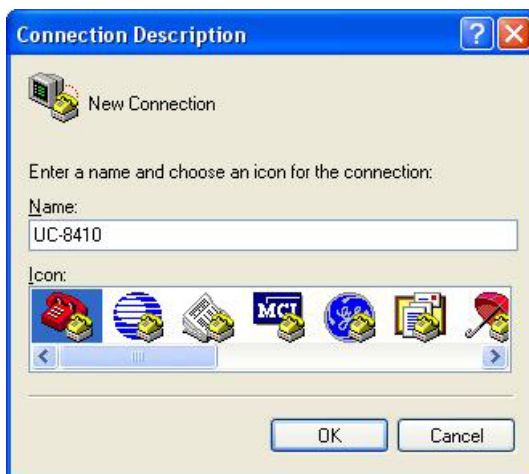

6. Click **Cancel** when the "Connect To" window opens.



7. Select **File → Properties** from the main HyperTerminal screen.

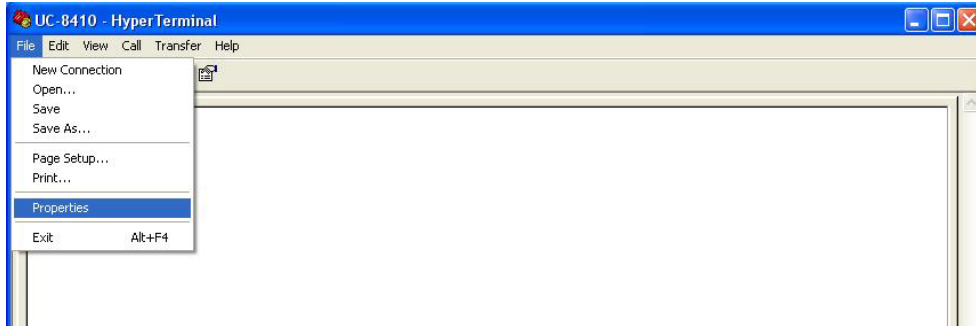

8. You can change the COM port number in the Properties window. Click **Configure** for additional configuration options.

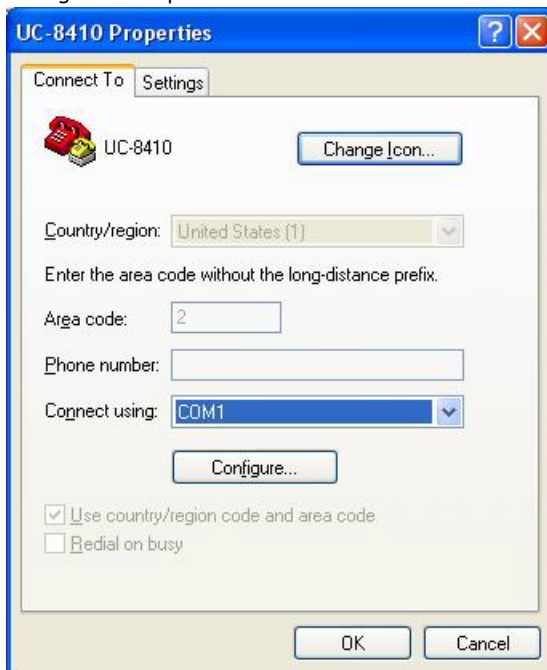

9. Configure the **Port Settings** with following parameters:

- Bits per second: 115200
- Data bits: 8
- Parity: None
- Stop bit: 1
- Flow control: None.

Click **OK** to continue.

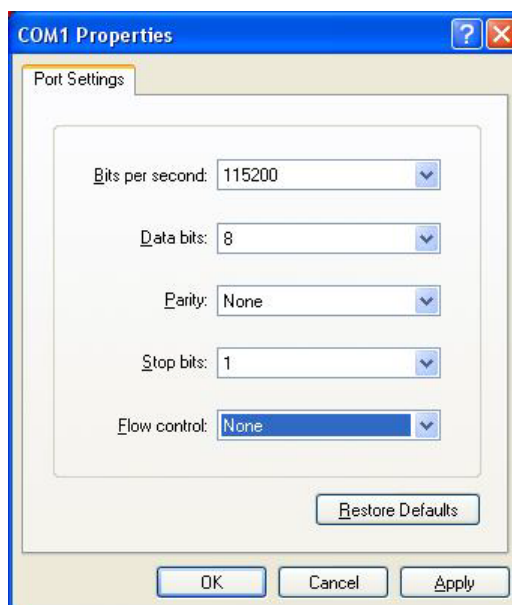

- Click the **Settings** tab and then select **VT100** (for Emulation). Click **OK** to complete the configuration.

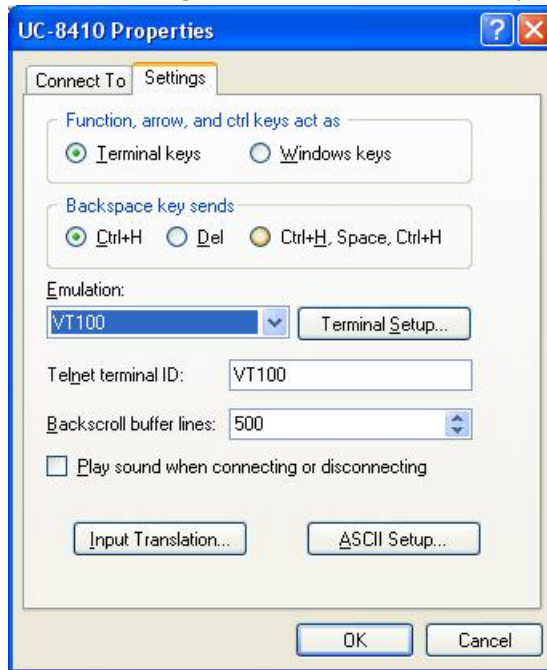

## B. Download and Installation of the TFTP Program

- You will need to download a free TFTP server package to upgrade the firmware for the boot loader utility. Link to the following URL to download:

<ftp://papa.indstate.edu/>

Download the TFTP program located in the following path:  
/winsock-1/Windows95/Daemons/TFTPD/

Download the file named **tftpd32d.zip**.

- When you have finished downloading, extract the files to your PC.

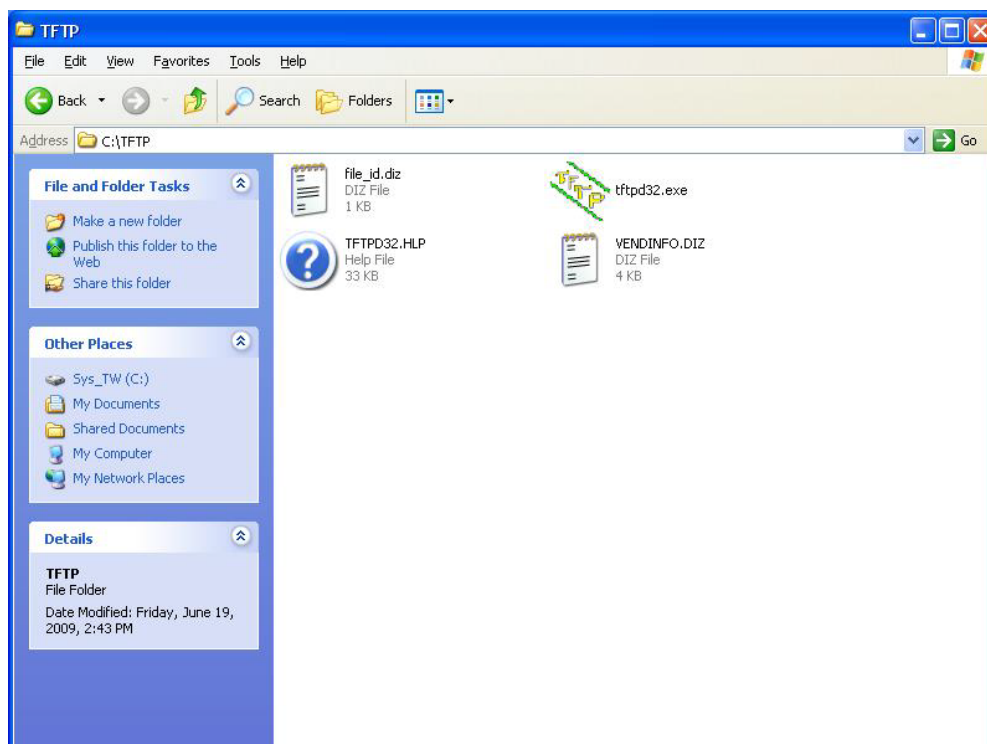

### C. Download and Upgrade the Firmware through HyperTerminal.

1. Connect to Moxa’s website at <http://www.moxa.com>, and then select Software from the Support drop-down menu.

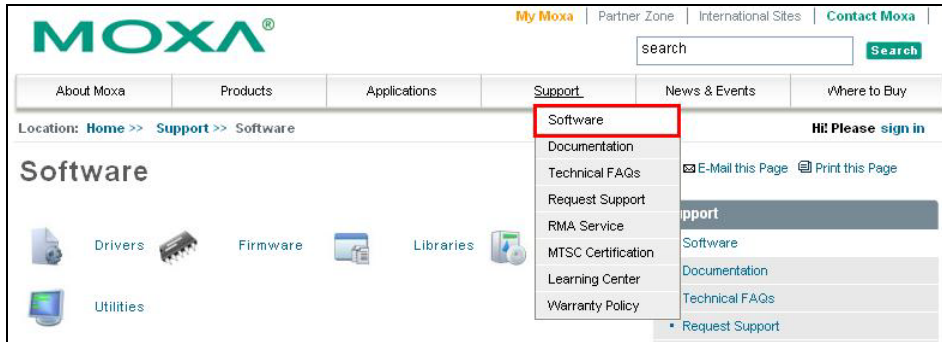

2. Under Search for Software, select the product line and then choose the specific product model. Click on **Search** to continue.

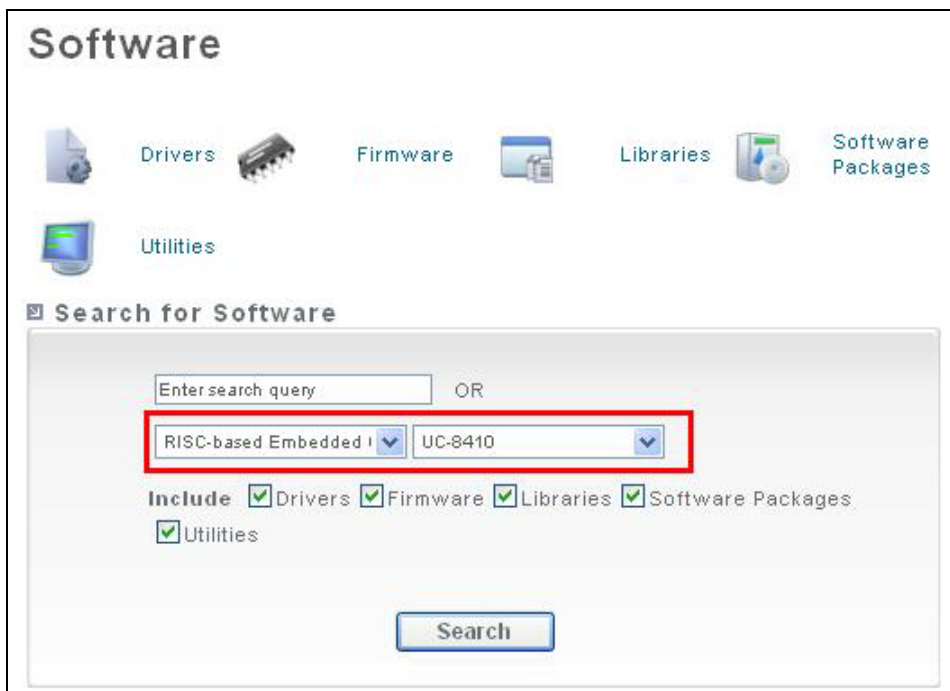

- In the software list, select the firmware for your model. Choose the appropriate OS and then click the download icon to start downloading the new firmware. **Note: Check the filename, it may differ from the filename shown below.**



- Put the latest firmware icon in the same directory as the TFTP files.

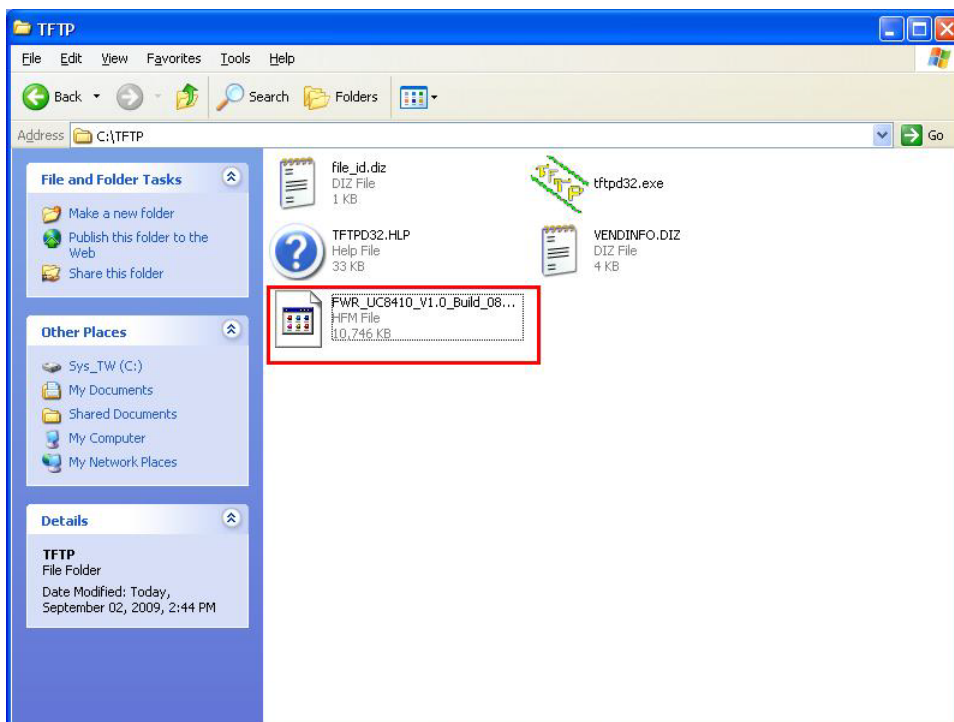

- Next, connect **LAN1** of the embedded computer to your PC using a cross-over Ethernet cable. The LAN1 port is located on the rear panel of the embedded computer.

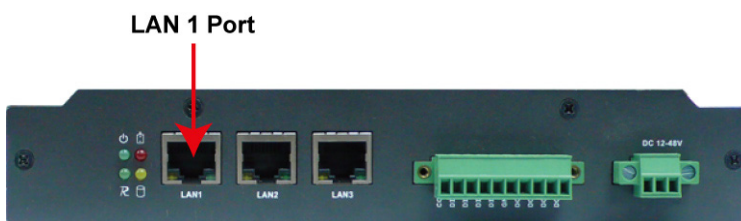



- Press and hold down the **DEL** key on your PC and power on the embedded computer at the same time. You will be guided to the boot loader utility menu, as show below.

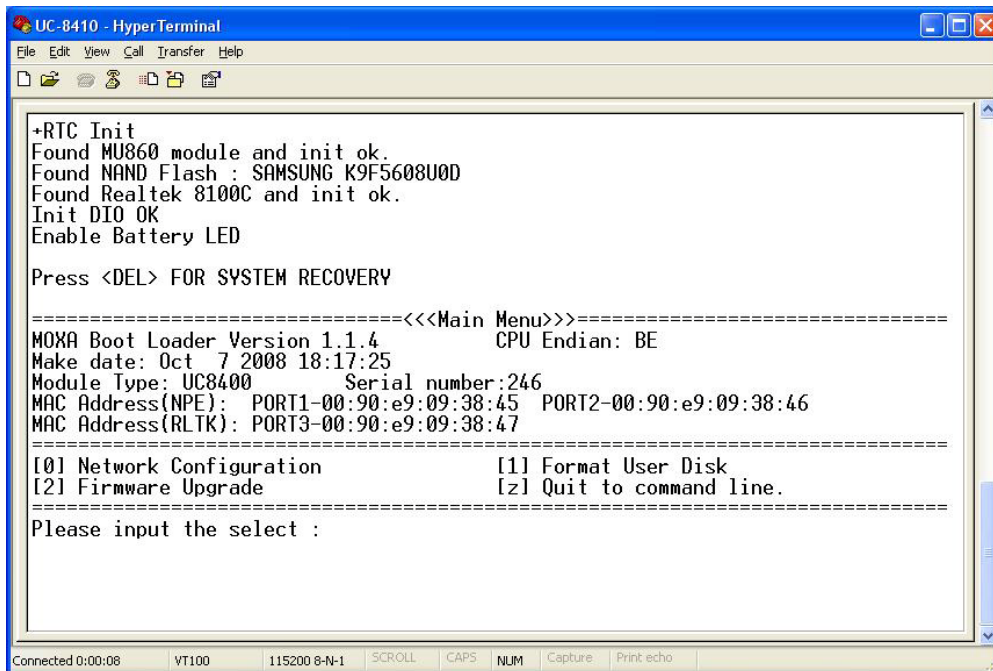

- In the boot loader utility, select **[0] Network Configuration**, and then **[0] Change IP Setting** to configure IP addresses.

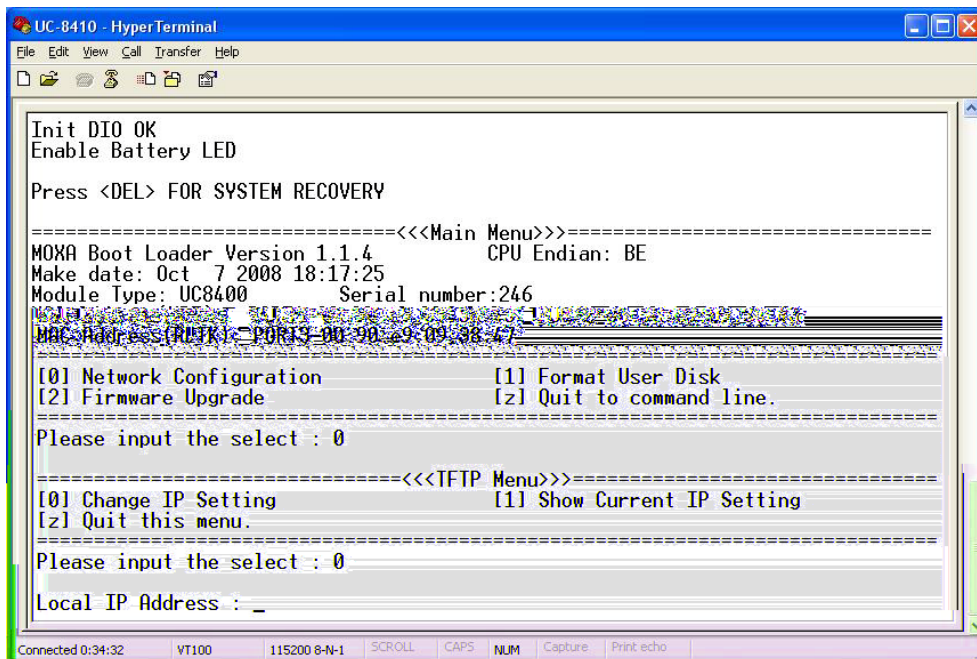

2. You will need to enter the IP address of the embedded computer and your PC. Follow the below to configure the IP addresses.
  - a. From **Start** → **Settings**, select **Network Connections**.

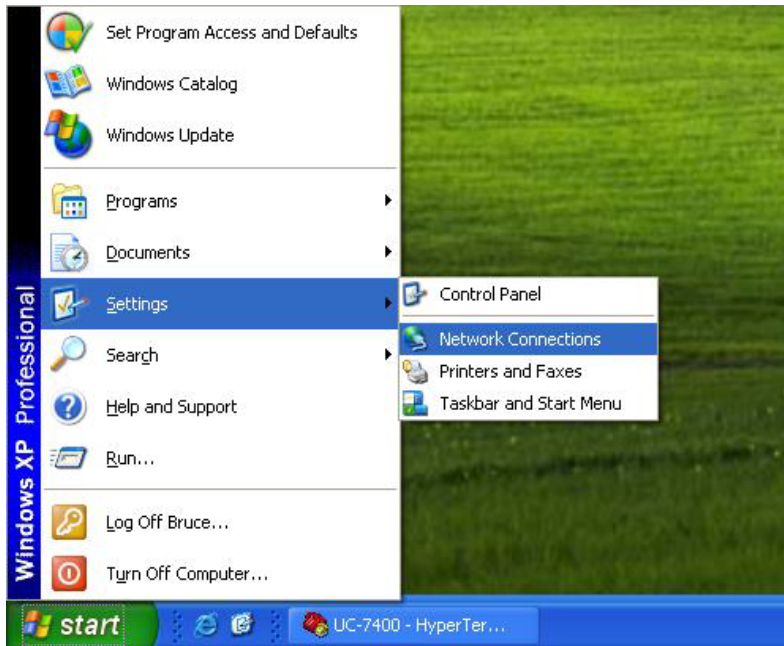

- b. Right-click on **Local Area Connection**, and then select **Properties**.

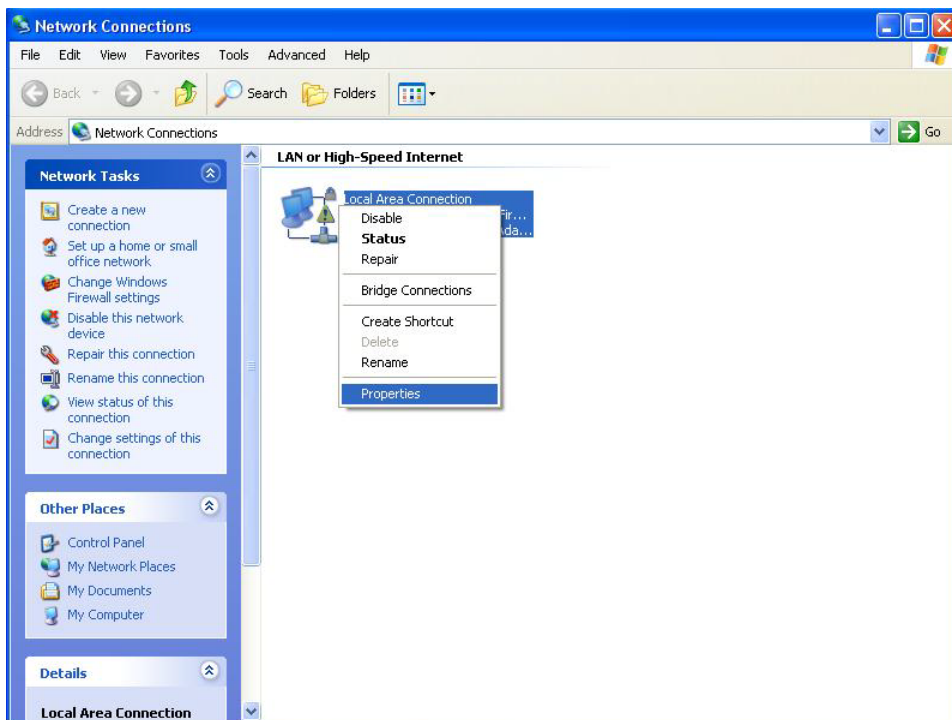

- c. Click the **General** tab and select **Internet Protocol (TCP/IP)**, and then click on **Properties**.

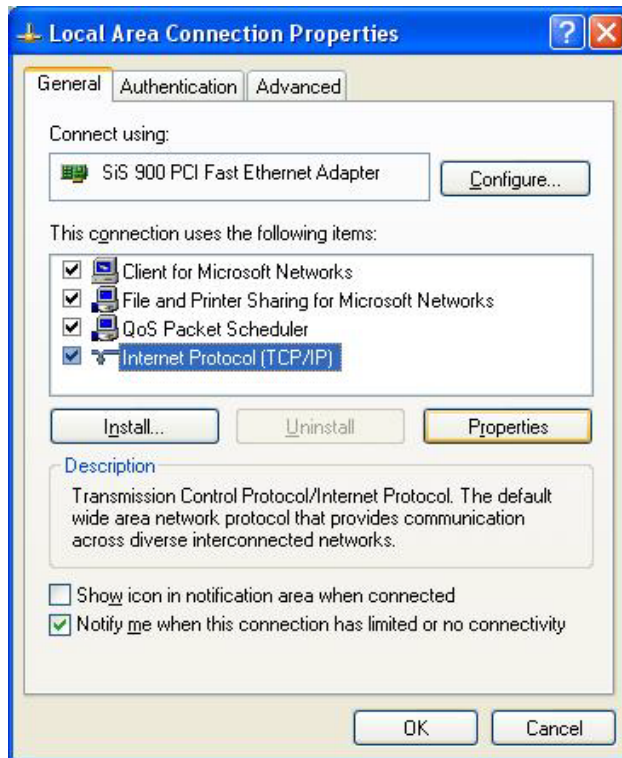

- d. Next, select **Use the following IP address** and enter the **IP address** and **Subnet mask**.  
For example:

**IP address: 192.168.1.1** (This IP address is only an example; you may assign any IP address of your choice as long as it's on the same LAN as your PC.)

**Subnet mask: 255.255.255.0**

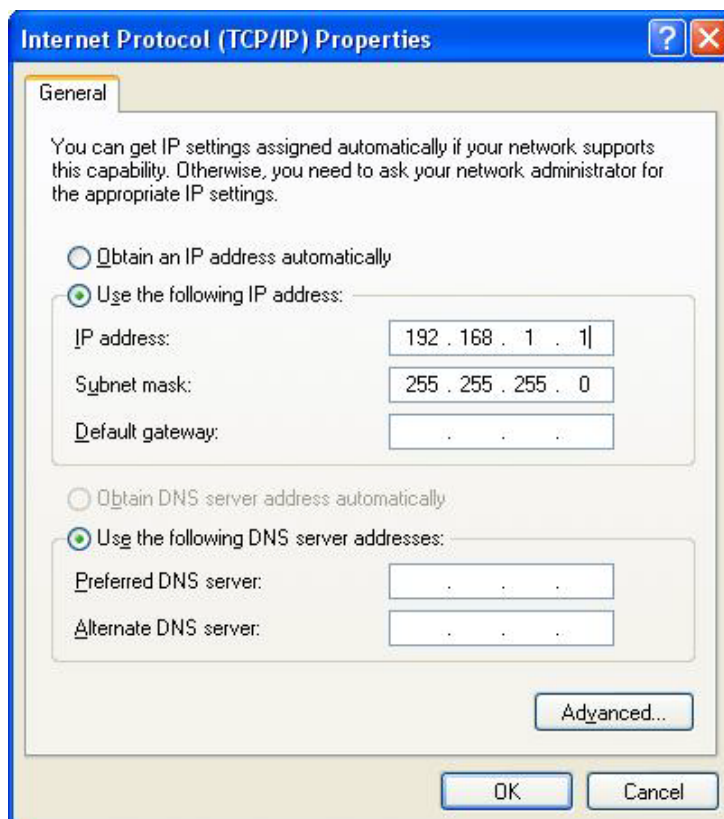

3. Go back to the boot load utility menu and assign the local IP address, and then enter the server IP address. The local IP address is the IP address of the embedded computer. **Note that the local IP address must be on the same LAN as the server IP address.** For example, if the server IP address is 192.168.1.1, you can choose a local IP address between 192.168.1.2 to 192.168.1.254.

```

UC-8410 - HyperTerminal
File Edit View Call Transfer Help
Please input the select : 0
Local IP Address : 192.168.1.2
bootp_my_ip: Setting to 192.168.1.2
... Unlock from 0x50fe0000-0x51000000: .
... Erase from 0x50fe0000-0x51000000: .
... Program from 0x0ffd0000-0x0fff0000 at 0x50fe0000: .
... Lock from 0x50fe0000-0x51000000: .
bootp_my_ip_mask: Setting to 255.0.0.0

Server IP Address : 192.168.1.1
bootp_server_ip: Setting to 192.168.1.1
... Unlock from 0x50fe0000-0x51000000: .
... Erase from 0x50fe0000-0x51000000: .
... Program from 0x0ffd0000-0x0fff0000 at 0x50fe0000: .
... Lock from 0x50fe0000-0x51000000: .

Set OK!

=====<<<TFTP Menu>>=====
[0] Change IP Setting           [1] Show Current IP Setting
[z] Quit this menu.
=====
Please input the select : _

```

4. Select **[z] Quit to command line** to exit the IP setting option. Next, select **[2] Firmware Upgrade**, and then **[0] Load from LAN** to continue.

```

UC-8410 - HyperTerminal
File Edit View Call Transfer Help
[0] Change IP Setting           [1] Show Current IP Setting
[z] Quit this menu.
=====
Please input the select : z

=====<<<Main Menu>>=====
MOXA Boot Loader Version 1.1.4      CPU Endian: BE
Make date: Oct 7 2008 18:17:25
Module Type: UC8400                Serial number:246
MAC Address(NPE): PORT1-00:90:e9:09:38:45  PORT2-00:90:e9:09:38:46
MAC Address(RLTK): PORT3-00:90:e9:09:38:47
=====
[0] Network Configuration         [1] Format User Disk
[2] Firmware Upgrade              [z] Quit to command line.
=====
Please input the select : 2

=====
Load method select :
0. Load from LAN
1. Load from serial with Xmodem
z. Abort select.
=====
Please select item : 0

```

5. To start the TFTP server, double-click on the **tftpd32** icon to launch the TFTP server.

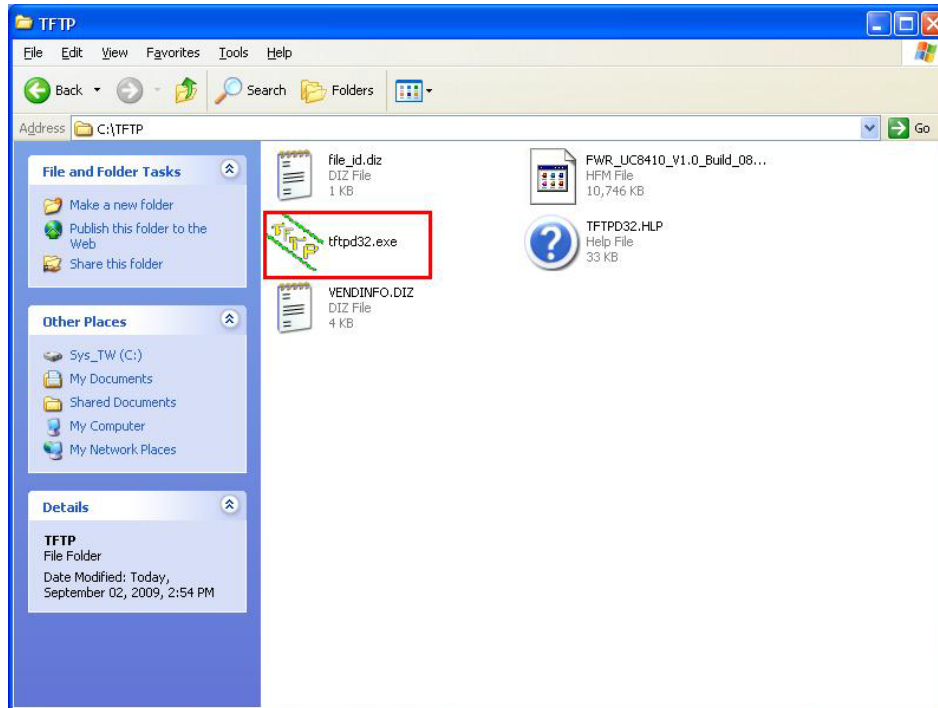

6. When the TFTP server has been launched, the following screen will appear.



- Go back to the boot loader utility menu and enter the file name of the firmware image.

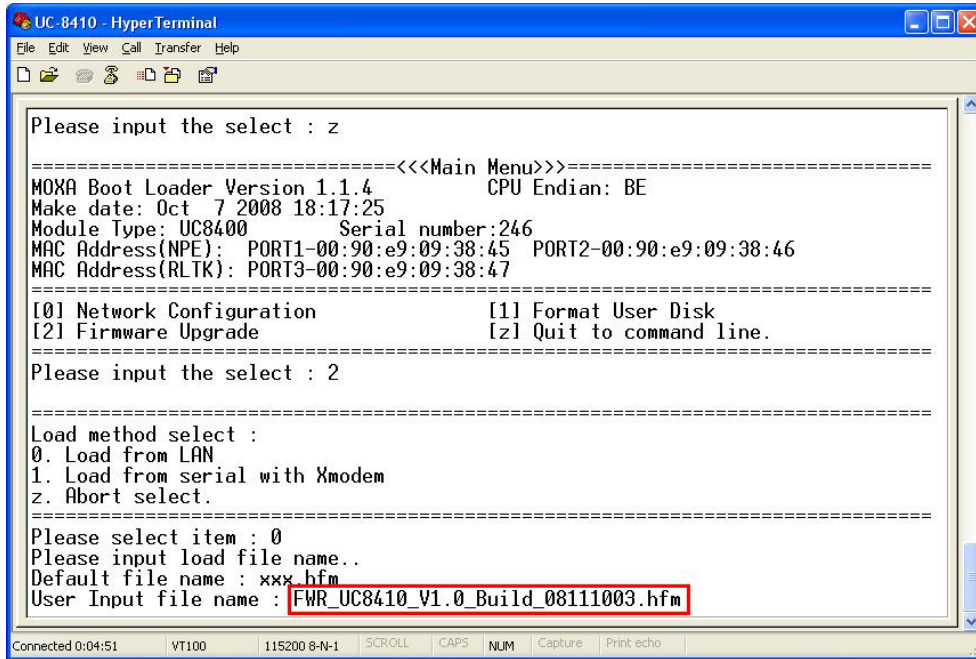

- The firmware upgrade will then start to run.

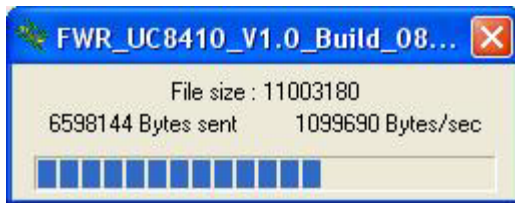

- It will take several minutes for the firmware files to be written to your embedded computer. **Do not power off your computer!**

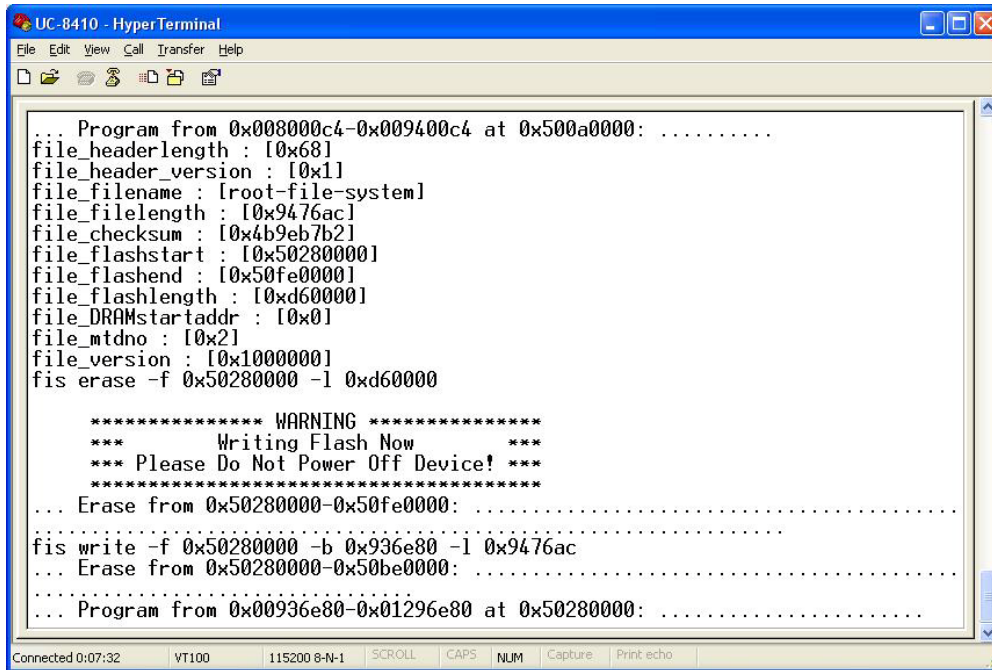

- When you see **Update OK**, the firmware upgrade is finished. At this point, you may reboot the embedded computer to complete the firmware upgrade or recovery from the boot loader utility.

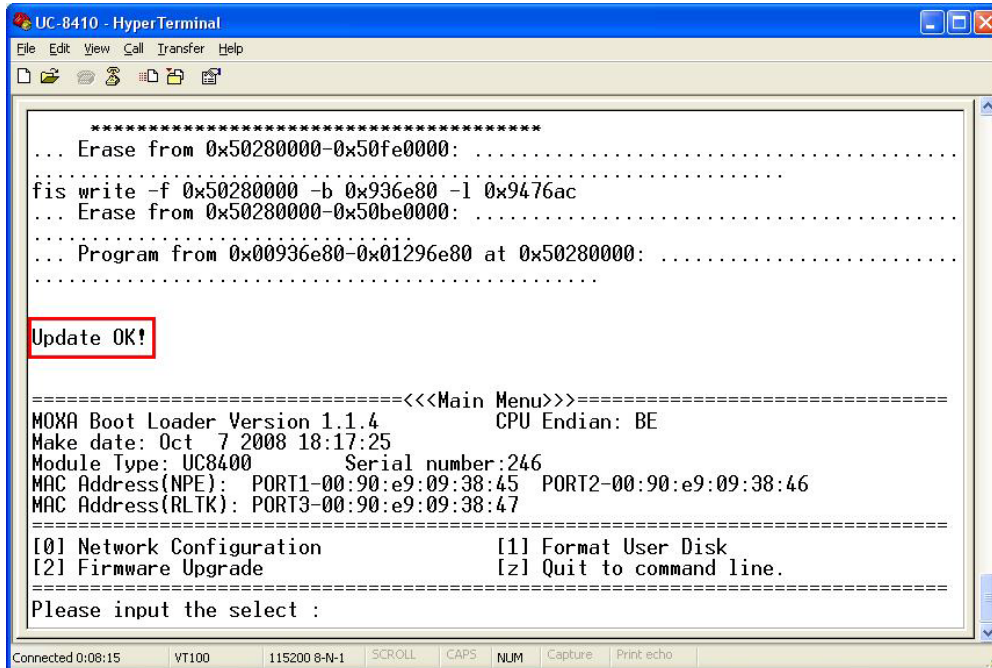

```
UC-8410 - HyperTerminal
File Edit View Call Transfer Help
*****
... Erase from 0x50280000-0x50fe0000: .....
fis write -f 0x50280000 -b 0x936e80 -l 0x9476ac
... Erase from 0x50280000-0x50be0000: .....
... Program from 0x00936e80-0x01296e80 at 0x50280000: .....

Update OK!

=====
MOXA Boot Loader Version 1.1.4          CPU Endian: BE
Make date: Oct 7 2008 18:17:25
Module Type: UC8400          Serial number: 246
MAC Address(NPE): PORT1-00:90:e9:09:38:45  PORT2-00:90:e9:09:38:46
MAC Address(RLTK): PORT3-00:90:e9:09:38:47
=====

[0] Network Configuration          [1] Format User Disk
[2] Firmware Upgrade              [z] Quit to command line.
=====

Please input the select :
```

- If you cannot reboot your embedded computer (after following all the steps above), contact Moxa's technical support staff for further assistance.

### Linux Normal Command Utility Collection

#### File Manager

cp	copy file
ls	list file
ln	make symbolic link file
mount	mount and check file system
rm	delete file
chmod	change file owner & group & user
chown	change file owner
chgrp	change file group
chroot	runs a command with a specified root directory.
sync	sync file system; save system file buffer to hardware
mv	move file
pwd	display active file directly
df	list active file system space
mkdir	make new directory
rmdir	delete directory
find	search for files in a directory hierarchy
head	output the first part of files
mkfifo	creates a FIFO, special character file, or special block file with the specified name
mknod	creates a FIFO, special character file, or special block file with the specified name
touch	change file timestamps
which	Locate a program file in the user's path.

#### Editor

vi	text editor
cat	dump file context
grep	Search string on file
egrep	search string on file of Extended regular expressions
fgrep	Search file(s) for lines that match a fixed string
cut	Get string on file
find	Find file where are there
more	dump file by one page
test	test if file exists or not
sleep	Sleep (seconds)
usleep	suspend execution for microsecond intervals
echo	echo string
sed	Stream editor



awk	pattern-directed scanning and processing language
expand	Converts all tabs to spaces
tail	Print the last 10 lines of each FILE to standard output.
tar	The GNU version of the tar archiving utility
tr	Translate, squeeze, and/or delete characters
wc	Print byte, word, and line counts, count the number of bytes, whitespace-separated words, and newlines in each given FILE, or standard input if non are given or for a FILE of `-'.

## Network

arp	manipulate the system ARP cache
ping	ping to test network
route	routing table manager
netstat	display network status
ifconfig	set network IP address
tftp	IPV4 Trivial File Transfer Protocol client
telnet	Connects the local host with a remote host, using the Telnet interface.
ftp	file transfer protocol
ifdown, ifup	bring a network interface up, or take a network interface down
ip	show / manipulate routing, devices, policy routing and tunnels
tcpsvd	TCP/IP service daemon
wget	The non-interactive network downloader.

## Process

kill	kill process
ps	display now running process
fuser	identify processes using files or sockets
killall	sends a signal to all processes running any of the specified commands
nice, renice	run a program with modified scheduling priority / alter priority of running processes
pidof	find the process ID of a running program
run-parts	run scripts or programs in a directory
start-stop-daemon	start and stop system daemon programs
top	display Linux tasks

## Modules

insmod	insert a module into the kernel
lsmod	shows which kernel modules are currently loaded
modprobe	intelligently adds or removes a module from the Linux kernel
rmmmod	remove module from kernel

## Other

dmesg	dump kernel log message
zcat	Dump .gz file context
free	display system memory usage
date	print or set the system date and time
env	run a program in a modified environment
clear	clear the terminal screen
reboot	reboot or power off/on the server

halt	halt the server
du	estimate file space usage
gzip, gunzip	compress or expand files
hostname	show system's host name basename return filename or directory portion of pathname
dirname	Convert a full pathname to just a path
expr	evaluate arguments as an expression
false	Do nothing, returning a non-zero (false) exit status
true	Do nothing, successfully
fdisk	Partition table manipulator for Linux
hwclock	A tool for accessing the Hardware Clock
id	Print the user identity
klogd	Kernel log daemon
logger	a shell command interface to the syslog system log module
md5sum	compute and check MD5 message digest
mesg	control write access to your terminal
mktemp	make temporary file name
nohup	No Hang Up
reset	terminal initialization
stty	change and print terminal line settings
syslogd	Linux system logging utilities
uname	Print system information, print information about the machine and operating system it is running on
uptime	Determine how long the system has been running
xargs	build and execute command lines from standard input
yes	'yes' prints the command line arguments, separated by spaces and followed by a newline, forever until it is killed.
tee	Copy standard input to each FILE, and also to standard output.

## Special Moxa Utilities

setkey	set the software encryption key
upgrahfm	upgrade firmware utility
libmoxalib.a	Moxa perporitary libraries
upramdisk	mount ramdisk
downramdisk	unmount ramdisk
kversion	show kernel version
setinterface	set /dev/ttyMn to RS232/RS485-2WIRES/RS422/ RS485-4WIRES