



AVEVA™

INDUSTRIAL COMPUTERS INTOUCH PANEL PC

Compact Series D

First Class Hardware Joins First Class Software

- Reduce installation, test, implementation, and maintenance time and effort
- Remove hardware/software incompatibility issues
- Gain flexibility with hardware independence
- Standardize and Save on Best in class
- Trust in a single source solution



Product at a glance

- Preinstalled HMI software – Fast implementation, consistency
- No Moving Parts – Durability/Reliability
- Replace old, obsolete, proprietary HMIs
- One source of support – Single Solution

InTouch Panel PC Compact Benefits

InTouch Panel PC Compact are the perfect complement to hardware/software standardization and reduction in total cost of ownership efforts. They are ruggedized for harsh environments, include a solid-state drive, and come pre-installed with the operating system, drivers and software powered by Wonderware for fast, easy, hassle-free testing, implementation, and maintenance.

This enables standardization on one common and powerful visualization interface for machine level applications and supervisory Human Machine Interface (HMI). Standardization helps leverage engineering investments, shorten development cycles, bring more value to users, and lower overall costs.

Break Free from Proprietary Hardware

Factory-tested, certified and ready to work right out of the box, the InTouch Panel PCs include pre installed InTouch HMI or InTouch Edge HMI software. Break free from functionally weak, proprietary and closed hardware products with

a fully functional Microsoft Windows based PC which gives you flexibility to run other software necessary to run your process.

The new Compact line offers the highest level of versatility. They are offered with Windows® Embedded Compact (formerly known as Windows CE) and InTouch Edge HMI all the way up to Windows Embedded Standard 7 and InTouch HMI.

Wide Variety of Mounting Options

Panel computers can be mounted in an enclosure or on a VESA-patterned pedestal. Box-only computers can be wall mounted or mounted directly to the back of any VESA-patterned monitor.

Advanced-Exchange Program

Advance-Exchange program to help you keep spare inventory costs down. If a device needs to be replaced, we send out the replacement immediately and let you send us back the original within 30 days. No need for deposit or pre-payment for replacement systems.

Just One Number to Call for Support!

We offer local support on a global scale from more than 200 locations around the globe, plus 1,500 Certified System Integrators, and with 24/7/365 technical support. Both hardware and software are supported by our award-winning Wonderware technical support organization.

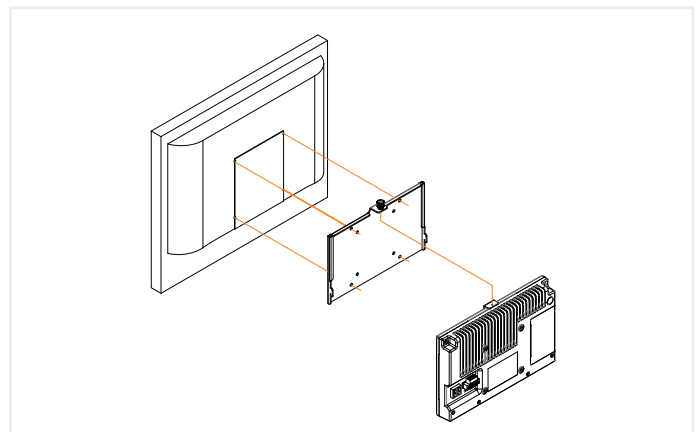



Panel PC Specifications

InTouch Panel PC: Compact	
Software Configuration	
OS	Windows Embedded Compact 7, Windows Embedded Standard 7 32-bit Windows 10 LTSC
Bundled Software	InTouch Edge HMI, InTouch Runtime, InTouch for System Platform
System Hardware	
Processor	Intel® Celeron™ N2930 Quad-Core Celeron 1.83 GHz
Memory	4 GB DDR3
Expandable	N
Graphics Processor	Intel HD graphics; DirectX 11.1, OpenCL/GL, 4K videos Quick Sync encoder
Drives	
Mass Storage	32 GB SATA SSD
Drive Mounting	On board removable
Built-in Disaster Recovery	N
Interface Ports	
Ethernet	2 x 10/100/1000 Mbps (isolated)
USB	2 or 3* x USB 2.0, 1 x USB 3.0
Serial	1 x RS-232/422/485, 1/2* x RS-232
External Video	1 x HDMI, 1 x VGA**
Audio	Line Out
General Features	
Modular Components	N
Fanless	Y
Expansion Slots	N
Rated Input Voltage	9-36 VDC (100-240 VAC external adapter included)
Environmental	
Protection Class	Front: IP65/NEMA 4; Rear: IP20/Fanless
Operating temperature	0°C to 50°C (32°F to 122°F)
Operating humidity	10 to 90% at 40°C (non-condensing)
Storage temperature	-25°C to +60°C (-13°F to 140°F)
Shock	DIN EN 60068-2-27/Operating: 15G, 11 ms duration
Vibration	DIN EN 60068-2-64/Operating: 10-500 Hz: 1G/3 axis
MTBF	LED-backlight: 100,000 hours in Eco mode
Certifications	
Safety Standards	
Europe	CE, based on 2006/95/EC
U.S.A. / Canada	UL/cUL/CB 61010, UL/cUL/CB 62368
EMC Standards	
Europe	EN 61000-6-4, EN 61000-6-3, CISPR22, RoHS
U.S.A. / Canada	FCC47 CFR PART 15: Class A level; IECS-003 Class B
* 7" has 2 x USB 2.0. 10.1", 12.1" & 15" have 3 x USB 2.0 ports ** On headless only	

Physical Dimensions/Power

Size	Display Material	Touch Type	Aspect Ratio	Resolution	Brightness	Cutout Dimensions (W x H)	Overall Dimensions (W x H x D)	Weight (kg / lb)	Power (W)	Current A (@ 24VDC)
Headless	n/a	n/a	n/a	n/a	n/a	n/a	246.3 x 139.8 x 29.9 mm	2.5 / 1.4	9	0.38
7"	Aluminum	Capacitive (Multi)	16:10	800 x 480	350	192 x 138 mm	202 x 149 x 39 mm	1.2 / 2.6	15	0.63
10.1"	Aluminum	Capacitive (Multi)	16:10	1280 x 800	350	272 x 176 mm	285 x 189 x 49 mm	2.1 / 4.6	12	0.50
12.1"	Aluminum	Capacitive (Multi)	4:3	800 x 600	330	303 x 229 mm	319 x 245 x 52 mm	2.5 / 5.5	14	0.58
15"	Aluminum	Capacitive (Multi)	4:3	1024 x 768	330	392 x 292 mm	401 x 310 x 55 mm	4.4 / 9.7	16	0.67
17"	Aluminum	Capacitive (Multi)	4:3	1280 x 1024	350	422 x 311 mm	439 x 348 x 64.8 mm	6.0 / 13.2	20W	0.6
19"	Aluminum	Capacitive (Multi)	4:3	1280 x 1024	350	450 x 362 mm	468 x 380 x 64.8 mm	5.9 / 13.0	30W	0.96
21.5"	Aluminum	Capacitive (Multi)	16:9	1920 x 1080	250	539 x 344 mm	557 x 362 x 65 mm	7.5 / 16.5	27W	0.98

Further Information

For more information on how Wonderware software can help you, visit our site: [aveva.com/monitor-and-control/hmi-supervisory-and-control/industrial-computers](https://www.aveva.com/monitor-and-control/hmi-supervisory-and-control/industrial-computers) Or contact your local Wonderware distributor.

The Industry's Leading Ecosystem

Our worldwide Partner Ecosystem represents thousands of partners all with the goal of helping you succeed. They can help you with InTouch as well as the full breadth of our Enterprise Control offerings.

Authorized Distributors – Our distributors combine their knowledge of our products with a clear understanding of your needs to assist you in the selection and purchase of the Wonderware products and related technologies.

System Integrator Partners – Our integrator partners can deliver cost effective solutions using our products across all industries, including yours. Today our Wonderware system integrator community includes more than 3,500 engineering firms worldwide.

Industry Solution Partners – Our solution partners work closely with application software providers, OEMs and VARs to offer industry-specific solutions.

Partner Products – These complementary products add value to solutions and expand the value of our solutions to our customers.

AVEVA Worldwide Offices | www.aveva.com/offices

AVEVA believes the information in this publication is correct as of its publication date. As part of continued product development, such information is subject to change without prior notice and is related to the current software release. AVEVA is not responsible for any inadvertent errors. All product names mentioned are the trademarks of their respective holders.

Copyright © 2019 AVEVA Group plc and its subsidiaries. All rights reserved.