

SolaHD Hardwire Power AC Distribution (PAD)

For use with S4KC Series UPS

User Manual — 30HWBP2U

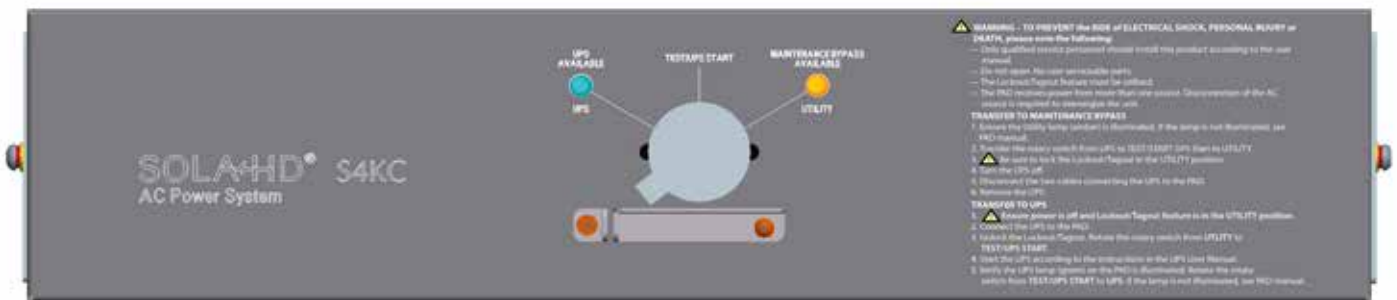

CONTENTS

Important Safety Instructions	1
Introduction and System Description	2
System Description	2
Rack Mount Installation	3
Installation on S4KC UPS	4
Hardwire Connections	5
Electrical Installation Considerations	5
Electrical Connections	6
Properly Grounded (Earthed) Equipment Provides Multiple Benefits.	6
Wiring Instructions	7
Apply Feed Power	8
Indicator Lamps	9
Utility	9
UPS Available	9
Operation	9
Transfer to Maintenance Bypass	10
Transfer to UPS	10
Troubleshooting	11
Specifications	12
Product Registration and Warranty Information	12

FIGURES

Figure 1 — UPS mode of operation. 2

Figure 2 — TEST/UPS START Mode 2

Figure 3 — Utility/maintenance bypass mode 2

Figure 4 — 30HWBP2U PAD with rack mounting brackets. 3

Figure 5 — Attaching PAD securing brackets to rear of UPS 4

Figure 6 — Conduit entry 5

Figure 7 — Removing wiring access doors 6

Figure 8 — Wiring 7

Figure 9 — Attaching PAD to securing brackets. 8

Figure 10 — Indicator lamps on 30HWBP2U PAD 9

Figure 11 — Switch Positions 10

TABLES

Table 1 — Breaker specifications 5

Important Safety Instructions

SAVE THESE INSTRUCTIONS

This manual contains important instructions that should be followed during installation and operation of the 30HWBP2U PAD. This product is designed for commercial / industrial use only, with SolaHD UPS systems. It is not intended for use with life support and other designated "critical" devices. Do not exceed PAD or UPS rating labels.

Read all safety and operating instructions before operating the 30HWBP2U PAD and the connected UPS system. Adhere to all warnings on the unit in this manual, and the UPS manual. Follow all operating and user instructions.

WARNING

Do not open the unit, no user serviceable parts. Refer to qualified service personnel for installation.

WARNING

The 30HWBP2U PAD must be grounded at all times while in use.

 **CAUTION:** This device receives power from multiple sources. Before servicing this device, remove all connections and disconnect power from the utility branch input. Before servicing the UPS, follow "Maintenance of UPS" instructions in the user manual for your UPS.

 **CAUTION:** This device is for use in a clean, indoor environment that is free of conductive contaminants. Route power cables so they are not walked on or pinched in any way. Refer to Specifications on page 12 for environmental conditions.

WARNING

When the 30HWBP2U PAD is in utility position (maintenance bypass mode) the power to the connected load is not filtered or conditioned by the UPS. The SolaHD UPS connected equipment guarantee is not valid while in this mode of operation.

Introduction and System Description

Congratulations on your choice of the SolaHD 30HWBP2U PAD.

The 30HWBP2U PAD provides maintenance bypass capability. The SolaHD 30HWBP2U PAD can be attached to the UPS or rack mounted.

The SolaHD 30HWBP2U PAD provides an isolated path of power for your UPS system for preventive maintenance or service. UTILITY, LOAD, and connections to and from the UPS are hardwired.

System Description

The 30HWBP2U PAD has three modes of operation: UPS (UPS available) ,UTILITY (maintenance bypass) and TEST/UPS START mode.

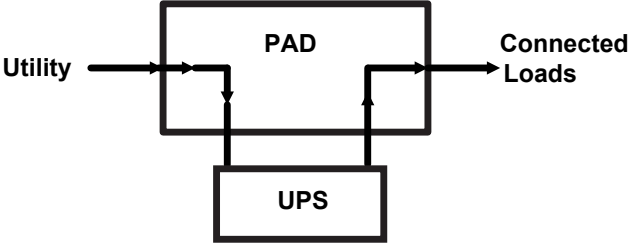
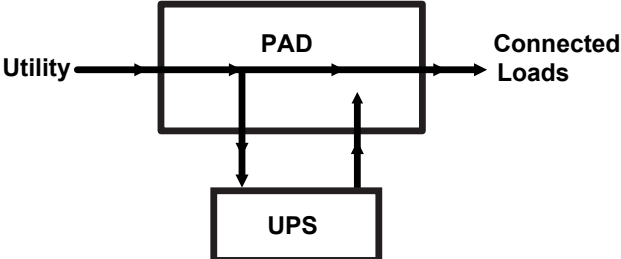
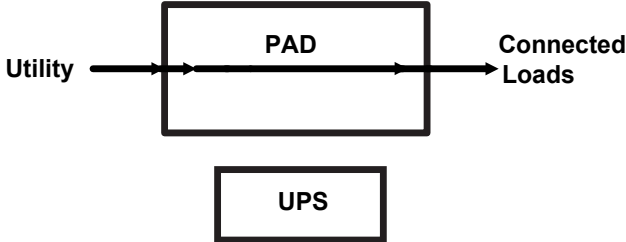
<ul style="list-style-type: none"> • During the UPS mode, the power is routed through the UPS system delivering conditioned power to the load. (see Figure 1) 	 <p>Figure 1: UPS Mode of Operation</p>
<ul style="list-style-type: none"> • During the UPS Start/Test mode, this allows the UPS that was previously taken out of service for maintenance or replacement to be tested while the connected equipment is still being powered by Utility power. (see Figure 2) 	 <p>Figure 2: TEST/UPS START Mode</p>
<ul style="list-style-type: none"> • During the UTILITY mode, the power is routed around (bypassing) the UPS system (see Figure 3). UTILITY power is supplied directly to the load through the 30HWBP2U PAD. 	 <p>Figure 3: Utility/Maintenance Bypass Mode</p>

The UPS may be turned off and removed without affecting the load with the presence of utility power.

Rack Mount Installation

1. Rack mount installation of the 30HWBP2U PAD is possible with the use of the rack mounting brackets (shipped with the PAD). See **Figure 4**. The rack mount brackets allow you to rack mount the PAD in a 19" enclosure (23" to 19" rack adapters are available as options from SolaHD).
2. The PAD can be mounted to face one of four directions depending on your application, and utilizing the rack mount brackets provided.
3. Conduit entry is possible on two sides of the PAD. Plan PAD orientation to allow for wiring. Determine the desired position and direction for the PAD, face it in that direction, and then attach the brackets to the PAD with the screws provided.
4. Consult your rack/enclosure manufacturer's recommendations for specific rack mounting hardware that will be required.
5. The holes on the rack mount bracket are notched for easy installation. Tighten the PAD securely to the rails and then follow the startup directions for the PAD in Installation on S4KC UPS.

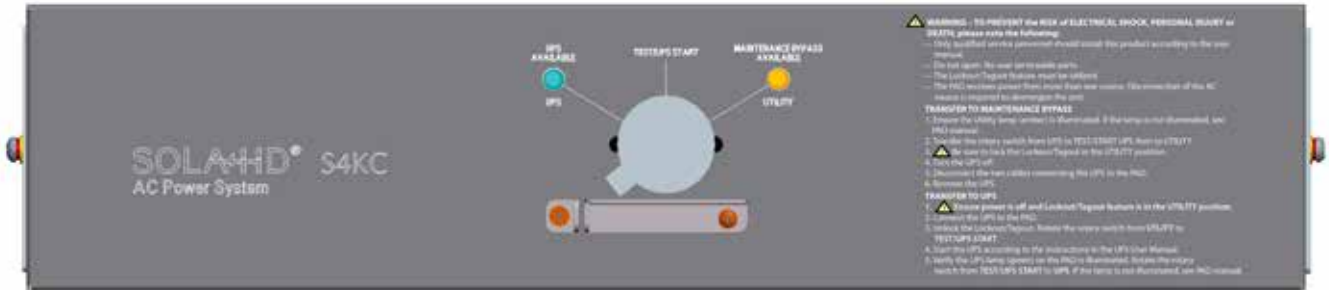

Figure 4: 30HWBP2U PAD with Rack Mounting Brackets

Shipment Accessories – 30HWBP2U

No.	Item Description	Quantity
1	Standard Component, Screw Assemblies	4
2	Support Hanger	2

Installation on S4KC UPS

NOTE:

This manual provides instructions for the 30HWBP2U PAD only. Refer to your UPS manual for UPS operation and installation instructions.

1. Unpack the 30HWBP2U PAD carefully, noting the packing method. Retain the box and packing material for possible future shipments.
2. Visually inspect the 30HWBP2U PAD for freight damage. Report damage to the carrier and your local dealer or SolaHD representative.
3. *Please refer to the section in your UPS manual for hardwire procedures. This may require you to remove the receptacle plate and cords from the UPS.*
4. If you already have a UPS installed with hardwire connections, turn off all connected UPS loads. Turn off the UPS and disconnect the corresponding hardwire connections.
5. The PAD can be installed to face one of three different directions utilizing the same mounting procedures. Refer to the *Apply Feed Power* section, see Figure 9.

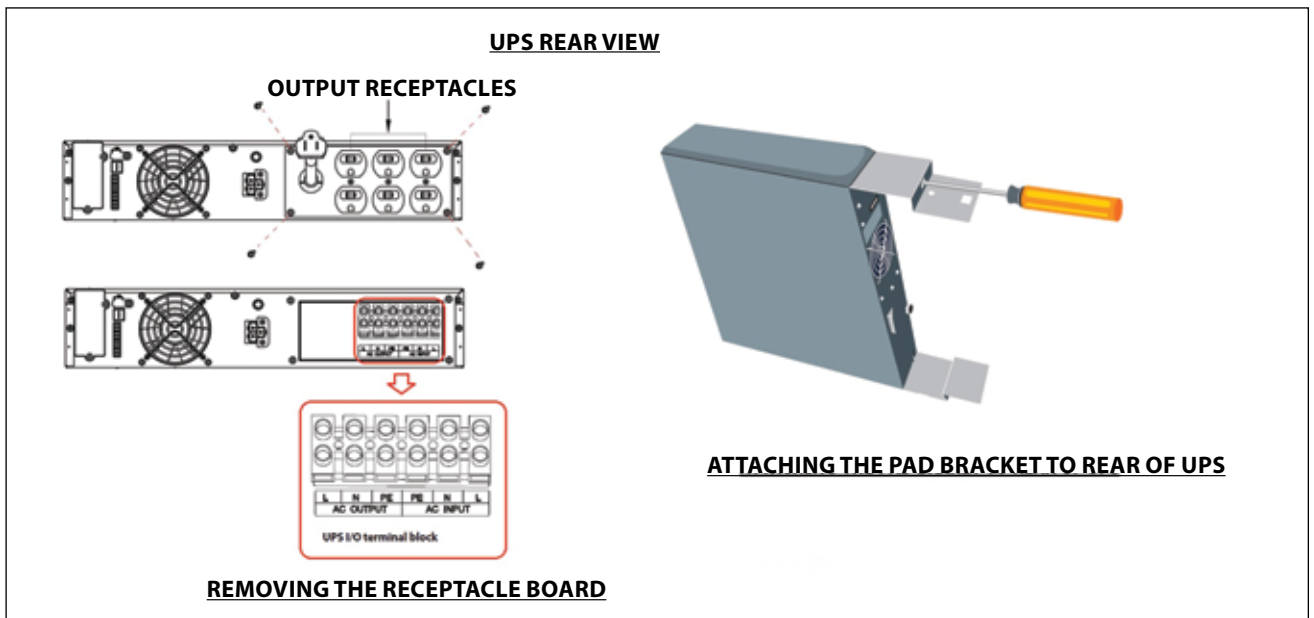

Figure 5: Attaching PAD securing brackets to rear of UPS and Removing the Receptacle Board

6. Attach the two PAD securing brackets (this is optional for S4K 2U UPS) to the rear of the UPS (see Figure 5). You will need a 7-in. (177.8 mm) long #1 Phillips head screwdriver for this procedure (torque is 7 in-lb, or 0.8 Nm). The PAD brackets have a hole to allow the screwdriver to reach the screw.

Hardware Connections

Electrical Installation Considerations

⚠ CAUTION: This UPS must be installed by qualified service personnel and wired in accordance with local/national electrical codes.

The utility input supply to the PAD must be protected by a branch rated circuit breaker. The breaker is to be mounted within 6 feet of the PAD and be readily accessible to the operator. Refer to Table 1 for breaker specification.

⚠ CAUTION: To reduce the risk of fire, connect only to a circuit provided with 30 amperes maximum branch circuit protection in accordance with ANSI/NFPA70 National Electric Code. Before installing, open all branch circuit power at the nearest disconnect, turn UPS off, and disconnect all cords to and from the UPS.

⚠ CAUTION: The UPS output must also be protected with a circuit breaker connected to the load, rated to carry the input current. Refer to the UPS manual for more information.

The front and bottom of the PAD provide alternate conduit entry points for both the UTILITY and LOAD connections.



Figure 6: Conduit Entry

Table 1: Breaker Specifications					
Model VA - Volt Rating	Input Current Rating at 120V*	Recommended (Maximum) External Overcurrent	Recommended Wire including Ground wire (75°C Copper Wire)	Maximum Wire Accepted By Terminal Block	Terminal Tightening Torque
30HWBP2U	24A	30A	8 or 10 AWG	8 AWG	12 in-lb

* See PAD Rating Plate for Alternate Output Voltages

Wiring access doors on each end of the PAD allow access to the wiring compartments by opening the top and rear of the PAD. Each access door is retained using two Phillips head screws.

Rear View

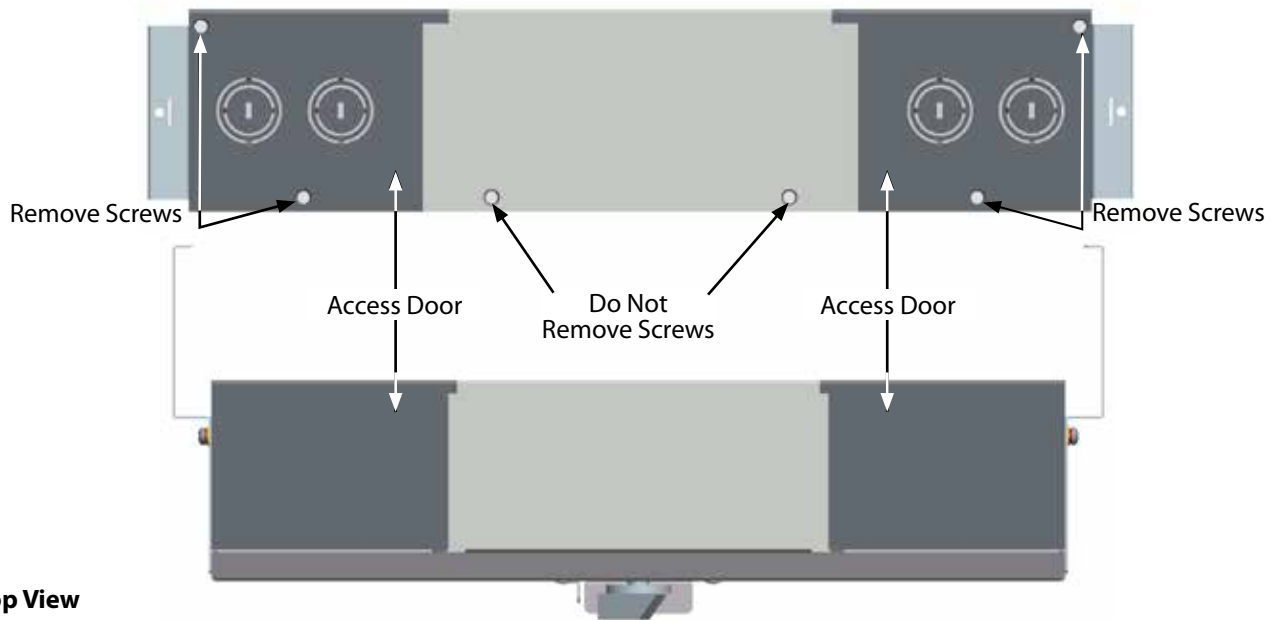

Top View

Figure 7: Removing Wiring Access Doors

Electrical Connections

The wiring compartments provide terminal blocks to connect Line, Neutral, and Ground for both the UTILITY input and LOAD output. The cable sizes and distribution methods used during installation are subject to local/national electrical codes of practice, and therefore are not detailed here. Table 1 details the standard current ratings

Properly Grounded (Earthed) Equipment Provides Multiple Benefits

High quality Ground (Earth) connections are required for the equipment ground conductors (Protective Earth) (power system earth connection) to provide for safe operation of the UPS and connected loads and to reduce electrical noise. Conduit used alone without a grounding conductor wire is not an acceptable connection. Size Ground (Protective Earth) conductors equal in size to circuit conductors. For wiring information, please refer to **Table 1**.

Wiring Instructions

1. Remove the wiring access doors by removing the two Phillips head screws that secure them.
2. Determine which of the two available conduit entry points are to be used. Knock out the conduit entry hole for the location and size of conduit to be used.
3. Connect conduit bushing and conduit and run utility load wiring. Inspect wiring to ensure it is not pinched. Make connections to the terminal blocks as labeled.

Close the wiring access doors and install the retaining screws.

Close the wiring access doors and install the retaining screws.



Rear View of 30HWBP2U

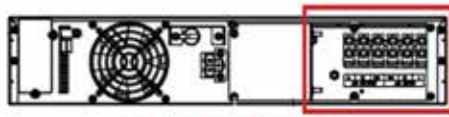

UPS I/O Terminal Block

UPS REAR VIEW

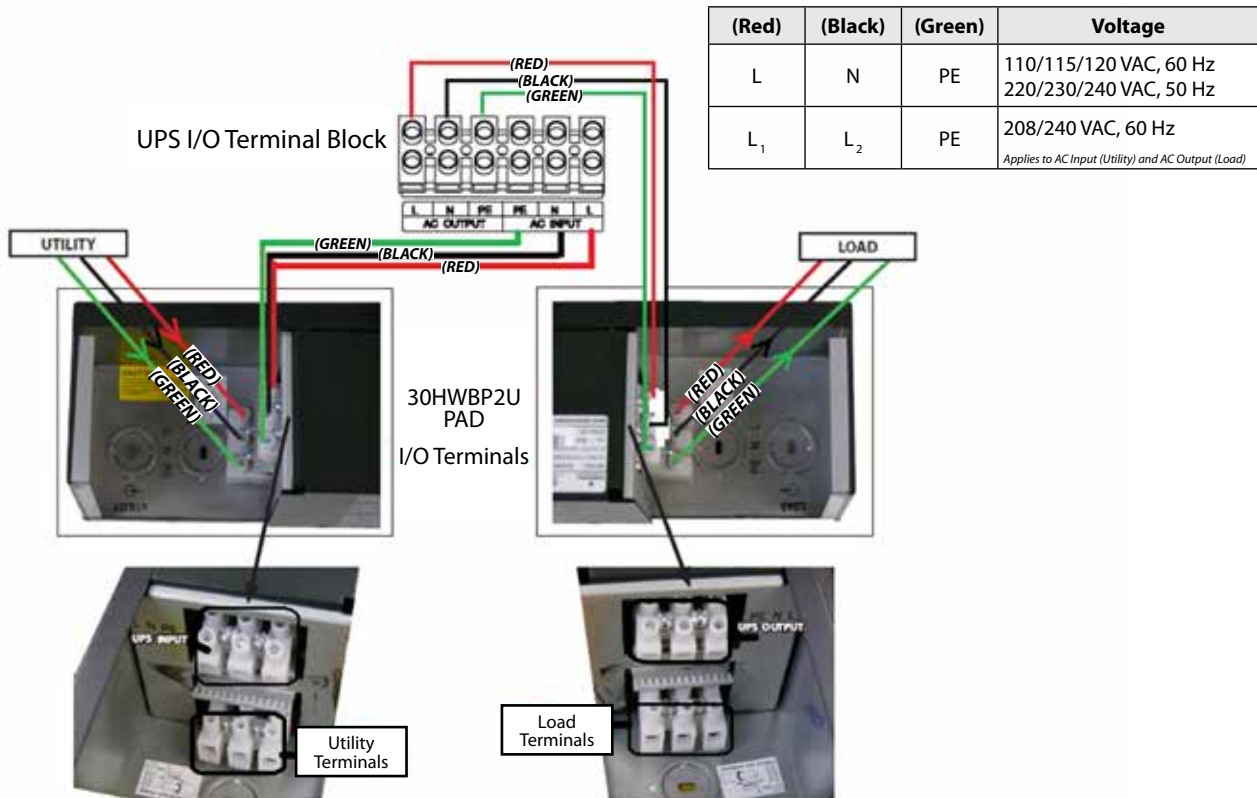

Figure 8: Wiring: 110/115/120 VAC, 60 Hz and 220/230/240 VAC, 50 Hz

Apply Feed Power

1. Attach the PAD to the securing brackets (see **Figure 9**). The PAD can be installed to face one of three different directions utilizing the same mounting procedures. Select the direction of mounting to accommodate the conduit entry connections.

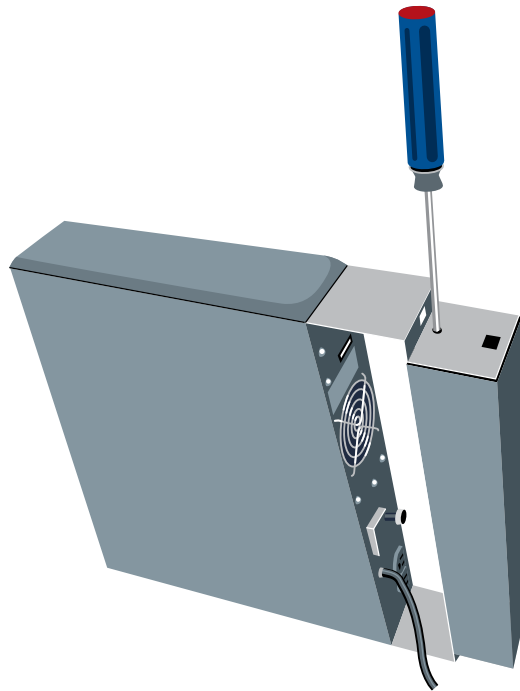

Figure 9: Attaching PAD to Securing Brackets

2. Make sure the 30HWBP2U PAD rotary switch is in the UTILITY position. Close the UTILITY input power branch circuit breaker.

⚠ WARNING

The 30HWBP2U PAD is now electrically live. The UTILITY lamp (amber) should now be illuminated.

3. Rotate the rotary switch from UTILITY to the TEST/UPS START position. Start up the UPS following the instructions found in the UPS user manual.

⚠ WARNING

The UPS system is now electrically live.

4. Once the UPS has started and is on, the UPS AVAILABLE lamp should illuminate (green). Once this lamp is lit, rotate the rotary switch from the TEST/UPS START to the UPS position. Your connected equipment is now protected from power disturbances.

Indicator Lamps

Utility

This amber lamp is illuminated when utility power is present. It signals that you may transfer the loads to maintenance bypass (UTILITY mode) operation via the rotary switch. During a utility power outage, this light will be off and the UPS will supply battery back-up power to the connected loads if the PAD rotary switch is in the UPS position.

UPS Available

This green lamp is illuminated when there is output power available from the UPS. It signals that it is safe to transfer the connected loads from utility power back to UPS output power.

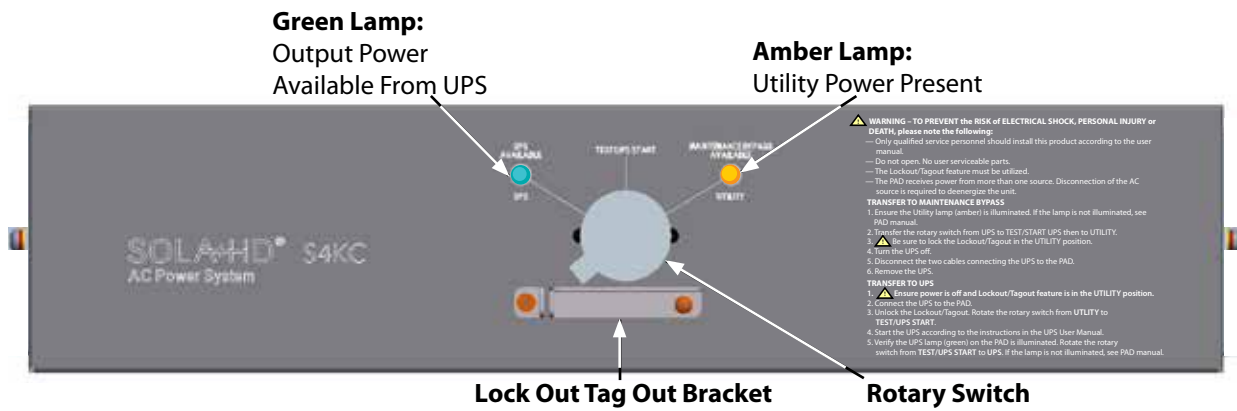

Figure 10: Indicator Lamps and Lock Out Tag Out feature on the 30HWBP2U

Operation

⚠ WARNING – TO PREVENT the RISK of ELECTRICAL SHOCK, PERSONAL INJURY or DEATH, please note the following:

- Only qualified service personnel should install this product according to the user manual.
- Do not open. No user serviceable parts.
- The Lockout/Tagout feature must be utilized.
- The PAD receives power from more than one source. Disconnection of the AC source is required to deenergize the unit.

Transfer to Maintenance Bypass

1. Ensure the Utility lamp (amber) is illuminated. If the lamp is not illuminated, refer to the Troubleshooting section.
2. Transfer the rotary switch from **UPS** to **TEST/STARTUPS** then to **UTILITY**.
3. **⚠ Be sure to lock the Lockout/Tagout in the UTILITY position.**
4. Turn the UPS off.
5. Disconnect the two cables connecting the UPS to the PAD.
6. Remove the UPS.

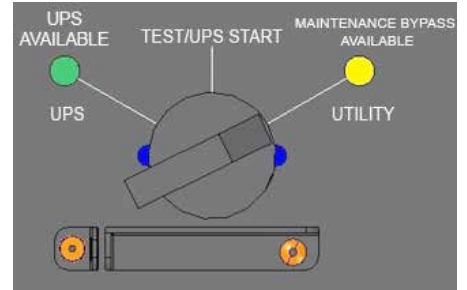

Transfer to UPS

1. **⚠ Ensure power is off and Lockout/Tagout feature is in the UTILITY position.**
2. Connect the UPS to the PAD.
3. Unlock the Lockout/Tagout. Rotate the rotary switch from **UTILITY** to **TEST/UPS START**.
4. Start the UPS according to the instructions in the UPS User Manual.
5. Verify the UPS lamp (green) on the PAD is illuminated. Rotate the rotary switch from **TEST/UPS START** to **UPS**. If the lamp is not illuminated, refer to the Troubleshooting section.

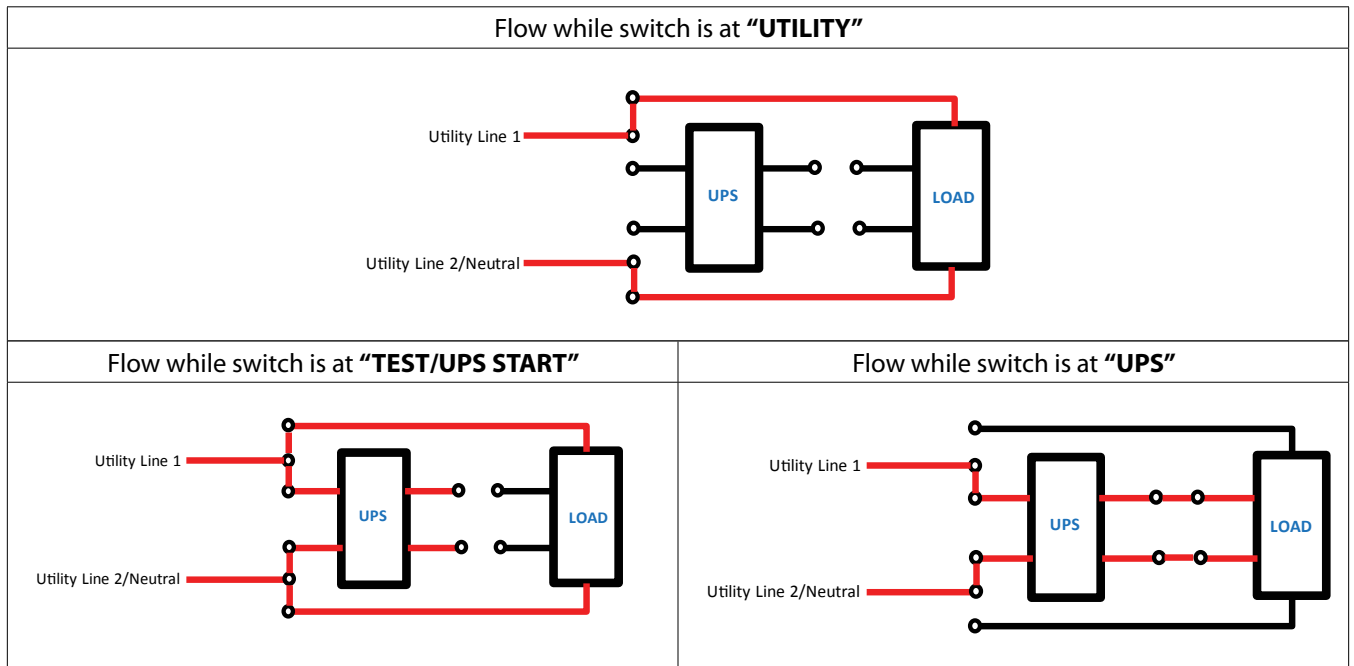

Figure 11: Switch Positions

Troubleshooting

Problem	Cause	Solution
UTILITY lamp (amber) not illuminated.	UTILITY not present.	Call qualified service personnel to restore power.
	Utility Branch Circuit Breaker may be open	Verify that the branch circuit breaker is closed.
	30HWBP2U PAD input power not connected to UTILITY.	Refer to 30HWBP2U PAD installation instructions in this manual: <ul style="list-style-type: none"> • Installation on S4KC UPS and • Rack Mount Installation.
UPS Available lamp (green) not illuminated.	UPS output power not present.	Turn on UPS. Refer to UPS user manual.
	UPS input and/or output cord not connected to 30HWBP2U PAD.	Refer to 30HWBP2U PAD installation instructions in this manual: <ul style="list-style-type: none"> • Installation on S4KC UPS and • Rack Mount Installation.
	UPS will not start up	Have qualified service personnel/electrician verify the wiring for proper connections and phase rotation
30HWBP2U PAD will not start some / all connected loads.	Input power cannot support load.	Verify that utility and UPS are on, all circuit protectors are closed, and load is within the rating of the power source.
Utility or UPS circuit protectors trip after resetting.	Load is in excess of UPS or circuit breaker rating.	Recalculate load requirements.
	Connections are not wired properly.	Have qualified service personnel verify the wiring for proper connections.

Specifications

Specifications	
Transfer Time (to and from maintenance bypass)	< 6 milliseconds
Operating Ambient Temperature	32°F to 104°F (0°C to +40°C)
Storage Ambient Temperature	-4°F to 140°F (-20°C to +60°C)
Dimensions with brackets W x D x H:	3.5 x 3.0 x 15.5 in. (88 x 77 x 394 mm)
Humidity	0 to 95% non-condensing
Certifications/Standards	cULus: UL1778,4th Edition/CSA C22.2 No. 107.3 CE: IEC 62040-1, ISTA Procedure 1A, EAC, ABS pending
Electrical Rating	110/115/120/208/220/230/240 VAC, 24A.

This PAD is intended for use with a UPS meeting all of the following requirements:

- Compatible UPS must have hardwire connections.
- UPS maximum current must not exceed 24A.
- Available utility is compatible with the PAD input connection and an appropriately sized branch circuit breaker has been provided.
- The 30HWBP2U PAD can be used with the following SolaHD models:

S4K2U700C 700 VA / 120 VAC

S4K2U1000C 1000 VA / 120 VAC

S4K2U1500C 1500 VA / 120 VAC

S4K2U2000C 2000 VA / 120 VAC

S4K2U3000C 3000 VA / 120 VAC

S4K2U1000-5C 1000 VA / 230 VAC

S4K2U2000-5C 2000 VA / 230 VAC

S4K2U3000-5C 3000 VA / 230 VAC

S4K5U6K5C which includes main cabinet: S4K5U6K5WOBATC 6000 VA / 230 VAC

Warranty Information

This will register your product with SolaHD.

Warranty Information

Please see enclosed "Terms & Conditions and Sales Policies & Procedures."

Also available online at www.solahd.com

Emerson brings integrated manufacturing solutions to diverse industries worldwide. Our comprehensive product line, extensive experience, world-class engineering and global presence enable us to implement solutions that give our customers the competitive edge. SolaHD is our premium line of power-conversion and power quality solutions products.

For over 150 years, our electrical product brands have been providing a rich tradition of long-term, practical, high quality solutions with applications ranging from the construction and safe operation of petrochemical and process plants to providing quality power that precisely controls automotive robotic production.

Engineers, distributors, contractors, electricians and site maintenance professionals around the world trust Emerson Industrial Automation brands to make electrical installations safer, more productive and more reliable.

Appleton Group is organized into three focused businesses that provide distributors and end-users expert knowledge and excellent service.

Electrical Construction Materials

This group is made up of the Appleton, Nutsteel and O-Z/Gedney brands. They manufacture a broad range of electrical products including conduit and cable fittings, plugs and receptacles, enclosures and controls, conduit bodies and industrial and hazardous lighting. Whether the application is hazardous location, industrial or commercial, the electrical construction materials group has the products to meet your needs.

Power Quality Solutions

The SolaHD brand offers the broadest power quality line, including uninterruptible power supplies, power conditioners, voltage regulators, shielded transformers, surge protection devices and power supplies.

Heating Cable Systems

This group is made up of the EasyHeat and Nelson brands. They offer a broad range of electrical heating cable products for residential, commercial and industrial applications.

Asia/Pacific
+ 65.6556.1100

Australia
+ 61.3.9721.0348

Canada
+ 1.888.765.2226

China
+ 86.21.3338.7000

Europe
+ 33.3.22.54.13.90

Mexico/Latin America
+ 52.55.5809.5049

Middle East/Africa/India
+ 971.4.811.8100

United States
+ 1.800.621.1506

Appleton Grp
9377 W. Higgins Road
Rosemont, IL 60018
1.800.377.4384
solahd.com

While every precaution has been taken to ensure the accuracy and completeness of this literature, SolaHD Corporation assumes no responsibility and disclaims all liability for damages resulting from use of this information or for any errors or omissions.

© 2016 SolaHD Corporation. All rights reserved throughout the world. Specifications subject to change without notice.

* SolaHD is a registered trademark of SolaHD Corporation. All names referred to are trademarks or registered trademarks of their respective owners.

Appleton Grp LLC d/b/a Appleton Group. The Appleton, O-Z/Gedney, SolaHD, EasyHeat, Nelson and Emerson logos are registered in the U.S. Patent and Trademark Office.

EasyHeat, Inc. is a wholly owned subsidiary of Appleton Grp LLC. All other product or service names are the property of their registered owners. © 2016, Appleton Grp LLC. All rights reserved.

P/N: A272-264 Rev. 1 01/2016

