

Rosemount™ 3051S Series Scalable™ Pressure, Flow, and Level Solution

with HART® Protocol



Safety messages

⚠ WARNING

Read this manual before working with the product. For personal and system safety, and for optimum product performance, ensure the contents are thoroughly understood before installing, using, or maintaining this product.

⚠ WARNING

Explosions could result in death or serious injury.

Do not remove the transmitter cover in explosive atmospheres when the circuit is live.

Fully engage both transmitter covers to meet explosion-proof requirements.

Before connecting a handheld communicator in an explosive atmosphere, ensure the instruments in the segment are installed in accordance with intrinsically safe or non-incendive field wiring practices.

Verify the operating atmosphere of the transmitter is consistent with the appropriate hazardous locations certifications.

⚠ WARNING

Electrical shock could cause death or serious injury.

Avoid contact with the leads and terminals.

⚠ WARNING

Process leaks could result in death or serious injury.

Install and tighten all four flange bolts before applying pressure.

Do not attempt to loosen or remove flange bolts while the transmitter is in service.

⚠ WARNING

Replacement equipment or spare parts not approved by Emerson for use as spare parts could reduce the pressure retaining capabilities of the transmitter and may render the instrument dangerous.

Use only bolts supplied or sold by Emerson as spare parts.

⚠ WARNING

Physical access

Unauthorized personnel may potentially cause significant damage to and/or misconfiguration of end users' equipment. This could be intentional or unintentional and needs to be protected against.

Physical security is an important part of any security program and fundamental in protecting your system. Restrict physical access by unauthorized personnel to protect end users' assets. This is true for all systems used within the facility.

NOTICE

Improper assembly of manifolds to traditional flange can damage SuperModule™ Platform.

For safe assembly of manifold to traditional flange, bolts must break back plane of flange web (also called bolt hole) but must not contact sensor module housing.

SuperModule and electronics housing must have equivalent approval labeling in order to maintain hazardous location approvals.

When upgrading, verify SuperModule and electronics housing certifications are equivalent. Differences in temperature class ratings may exist, in which case the complete assembly takes the lowest of the individual component temperature classes (for example, a T4/T5 rated electronics housing assembled to a T4 rated SuperModule is a T4 rated transmitter.)

Severe changes in the electrical loop may inhibit HART® communication or the ability to reach alarm values. Therefore, Emerson cannot absolutely warrant or guarantee that the correct failure alarm level (HIGH or LOW) can be read by the host system at the time of annunciation.

NOTICE

The products described in this document are NOT designed for nuclear-qualified applications.

Using non-nuclear qualified products in applications that require nuclear-qualified hardware or products may cause inaccurate readings.

For information on Rosemount nuclear-qualified products, contact [Emerson.com/global](https://www.emerson.com/global).

Contents

Chapter 1	Introduction.....	7
	1.1 Models covered.....	7
	1.2 Product recycling/disposal.....	8
Chapter 2	Configuration.....	9
	2.1 Overview.....	9
	2.2 Commissioning on the bench.....	9
	2.3 Field Communicator.....	10
	2.4 Field Communicator menu trees.....	12
	2.5 Check output.....	25
	2.6 Basic setup.....	27
	2.7 LCD display (Optional Order Code).....	32
	2.8 Detailed setup.....	33
	2.9 Diagnostics and service.....	41
	2.10 Advanced functions.....	43
	2.11 Multidrop communication	46
Chapter 3	Hardware Installation.....	49
	3.1 Overview.....	49
	3.2 Considerations.....	49
	3.3 Installation procedures.....	54
	3.4 Flange bolt installation.....	64
	3.5 Wiring the device.....	85
Chapter 4	Operation and maintenance.....	95
	4.1 Calibration for HART [®] Protocol.....	95
	4.2 Field upgrades.....	108
Chapter 5	Troubleshooting.....	109
	5.1 Disassembly procedures.....	109
	5.2 Reassembly procedures.....	112
Chapter 6	Safety Instrumented Systems (SIS).....	115
	6.1 Rosemount 3051S safety certified identification.....	115
	6.2 Installation in SIS applications.....	115
	6.3 Configuring in SIS applications.....	116
	6.4 Damping	116
	6.5 Alarm and saturation levels.....	116
	6.6 SIS Operation and maintenance.....	118
	6.7 Inspection.....	120
Chapter 7	Advanced HART Diagnostic Suite.....	123
	7.1 Advanced HART [®] Diagnostic Suite.....	123
Appendix A	Appendix A: Specifications and Reference Data.....	163
	A.1 Product Certifications.....	163

A.2 Ordering Information, Specifications, and Drawings..... 163

1 Introduction

1.1 Models covered

The following transmitters and the Rosemount 300S Housing Kit are covered in this manual:

The Rosemount 3051S provides a wide range of applications, and many of these different applications have their own reference manuals. This manual covers the 3051S HART®, Advanced Diagnostics, and Safety Instrumented Systems (SIS).

Table 1-1: Rosemount 3051S Coplanar™ Pressure Transmitter

Performance class	Measurement type		
	Differential	Gauge	Absolute
Ultra	X	X	X
Ultra for Flow	X	N/A	N/A
Classic	X	X	X

Table 1-2: Rosemount 3051S In-Line Pressure Transmitter

Performance class	Measurement type		
	Differential	Gauge	Absolute
Ultra	N/A	X	X
Classic	N/A	X	X

Table 1-3: Rosemount 3051S Liquid Level Pressure Transmitter

Performance class	Measurement type		
	Differential	Gauge	Absolute
Classic	X	X	X

Table 1-4: Rosemount 3051S SIS Safety Certified Transmitter

Performance class	Measurement type		
	Differential	Gauge	Absolute
Classic	X	X	X

Table 1-5: Rosemount 3051S Transmitter with FOUNDATION™ Fieldbus Diagnostics Transmitter

Performance class	Measurement type		
	Differential	Gauge	Absolute
Ultra	X	X	X
Ultra for Flow	X	N/A	N/A
Classic	X	X	X

For information on other 3051S transmitters, refer to the following reference manuals:

- [Rosemount 3051S Pressure Transmitter with FOUNDATION Fieldbus Protocol Reference Manual](#)
- [Rosemount 3051S Wireless Series Reference Manual](#)
- [Rosemount 3051S Electronic Remote Sensor \(ERS™\) System Reference Manual](#)
- [Rosemount 3051S MultiVariable™ Transmitter Reference Manual](#)

Rosemount 300S Scalable Housing Kits

Kits are available for all models of 3051S Pressure Transmitters.

1.2 Product recycling/disposal

Consider recycling equipment and packaging.

Dispose of the product and packaging in accordance with local and national legislation.

2 Configuration

2.1 Overview

This section contains information on commissioning and tasks that should be performed on the bench prior to installation.

Instructions for performing configuration functions are given for handheld communication devices like the Field Communicator or asset management software like Emerson's AMS Device Manager. For convenience, Field Communicator Fast Key sequences (where supported) are labeled *Fast Keys* for each software function below the appropriate headings.

2.1.1 Example software function

The Device Dashboard Fast Keys apply to Device Descriptor Revision 9 or newer. The HART® 5 with Diagnostics Fast Keys apply to Device Descriptor Revision 1. The HART 7 Fast Keys apply to Device Descriptor Revision 2. Contact Emerson or refer to previous reference manuals for information on older revisions.

Device Dashboard Fast Keys	1, 2, 3, etc.
HART 5 with Diagnostics Fast Keys	1, 2, 3, etc.
HART 7 Fast Keys	1, 2, 3, etc.

2.2 Commissioning on the bench

Commissioning consists of testing the transmitter and verifying transmitter configuration data. Rosemount™ 3051S Pressure Transmitters can be commissioned either before or after installation. Commissioning the transmitter on the bench before installation using a Field Communicator or AMS Device Manager ensures all transmitter components are in working order.

Equipment required to commission on the bench includes a power supply, a milliamp meter, and a Field Communicator or AMS Device Manager. Wire the equipment as shown in [Figure 2-1](#). Verify transmitter terminal voltage is between 10.5–42.4 Vdc. To ensure successful communication, a resistance of at least 250 ohms must be present between the Field Communicator loop connection and the power supply. Connect the Field Communicator leads to the terminals labeled PWR/COMM on the terminal block. (Connecting across the "TEST" terminals will prevent successful communication.)

Set all transmitter hardware adjustments during commissioning to avoid exposing the transmitter electronics to the plant environment after installation. Refer to [Wire the device](#).

When using a Field Communicator, any configuration changes made must be sent to the transmitter by using the **Send** key. AMS Device Manager configuration changes are implemented when the **Apply** button is selected.

2.2.1 Setting the loop to Manual

Whenever sending or requesting data that would disrupt the loop or change the output of the transmitter, set the process application loop to **Manual**. The Field Communicator or AMS Device Manager will prompt you to set the loop to manual when necessary.

Acknowledging this prompt does not set the loop to **Manual**. The prompt is only a reminder; set the loop to manual as a separate operation.

2.2.2 Wiring diagrams

Bench hook-up

Connect the bench equipment as shown in [Figure 2-1](#), and turn on the Field Communicator or log into AMS Device Manager. The Field Communicator or AMS Device Manager will search for a HART®-compatible device and indicate when the connection is made. If the Field Communicator or AMS Device Manager fail to connect, it indicates that no device was found. If this occurs, refer to [Troubleshooting](#).

Field hook-up

[Figure 2-1](#) illustrates wiring loops for a field hook-up with a Field Communicator or AMS Device Manager. The Field Communicator or AMS Device Manager may be connected at “PWR/COMM” on the transmitter terminal block, across the load resistor, or at any termination point in the signal loop. Signal point may be grounded at any point or left ungrounded.

Figure 2-1: Typical wiring (4–20 mA)

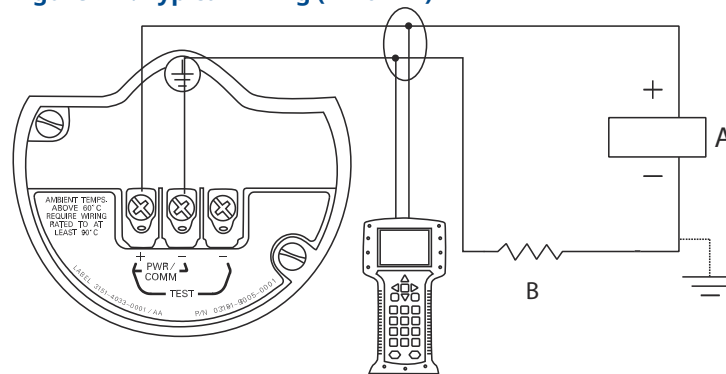

- A. Power supply
- B. $RL \geq 250\Omega$

2.3 Field Communicator

For convenience, Field Communicator Fast Key sequences are labeled **Fast Keys** for each software function below the appropriate headings. The Device Dashboard Fast Keys apply to Device Descriptor Revision 9 or newer. The HART® 5 with Diagnostics Fast Keys apply to Device Descriptor Revision 1. The HART 7 Fast Keys apply to Device Descriptor Revision 2.

2.3.1 Field Communicator user interface

Figure 2-2: HART 5 with Diagnostics Dashboard

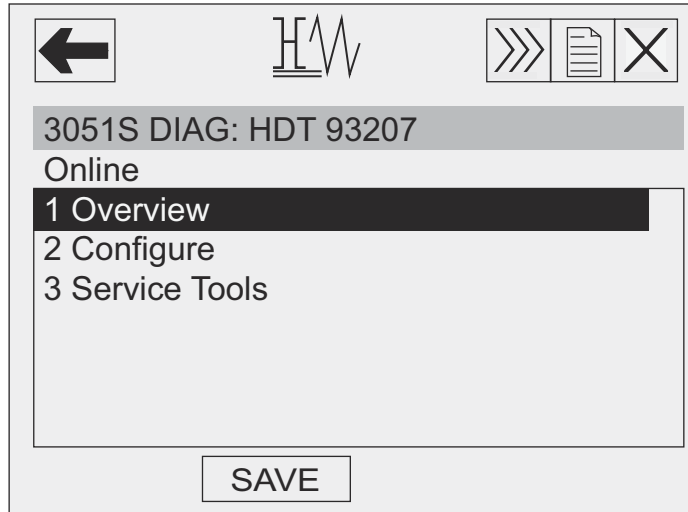

Note

The corresponding menu tree is shown in [Figure 2-3](#). The Fast Key sequence can be viewed on [Device Dashboard Fast Key sequence](#).

2.4 Field Communicator menu trees

Device Dashboard menu tree

Figure 2-3: Overview

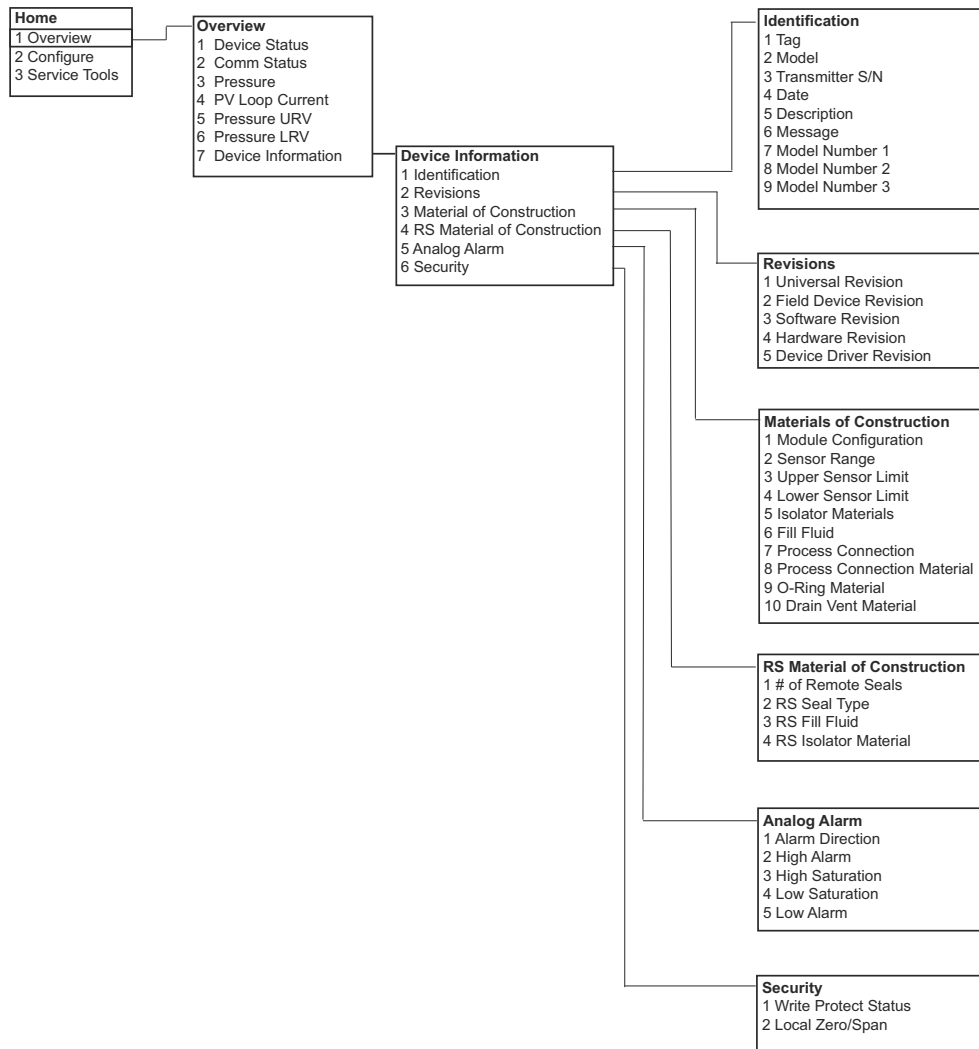

Figure 2-4: Configure

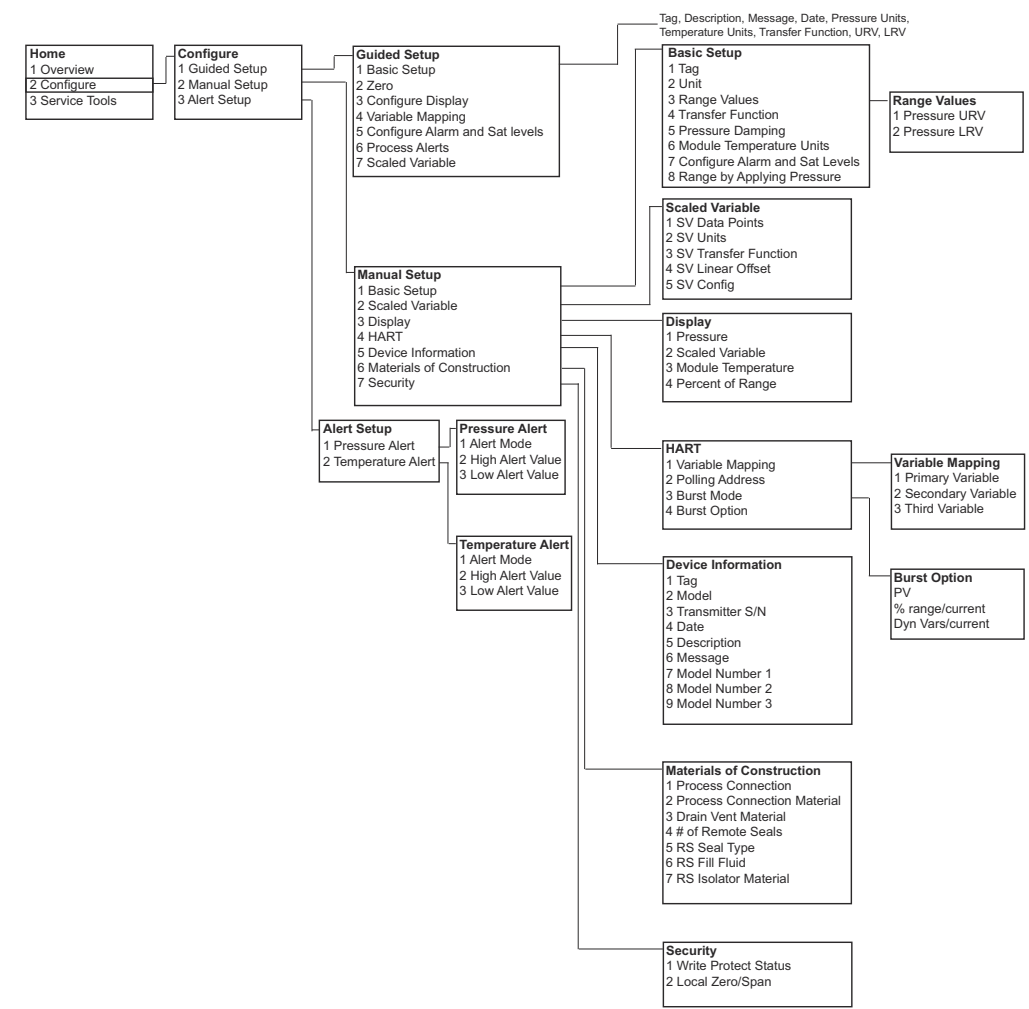
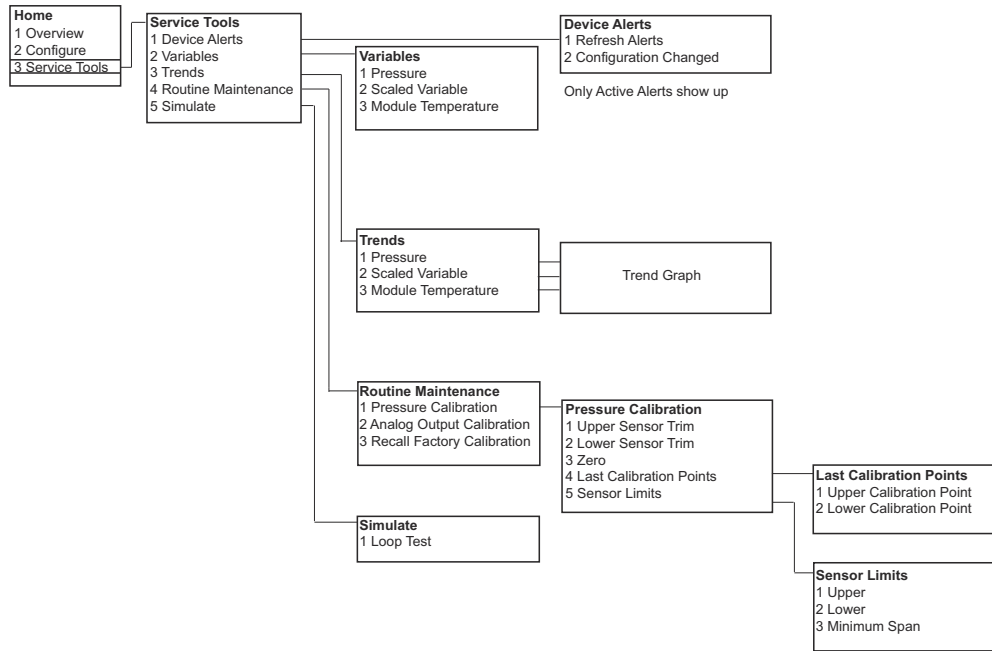

Figure 2-5: Service Tools



HART 5 with Diagnostic menu trees

Figure 2-6: Overview

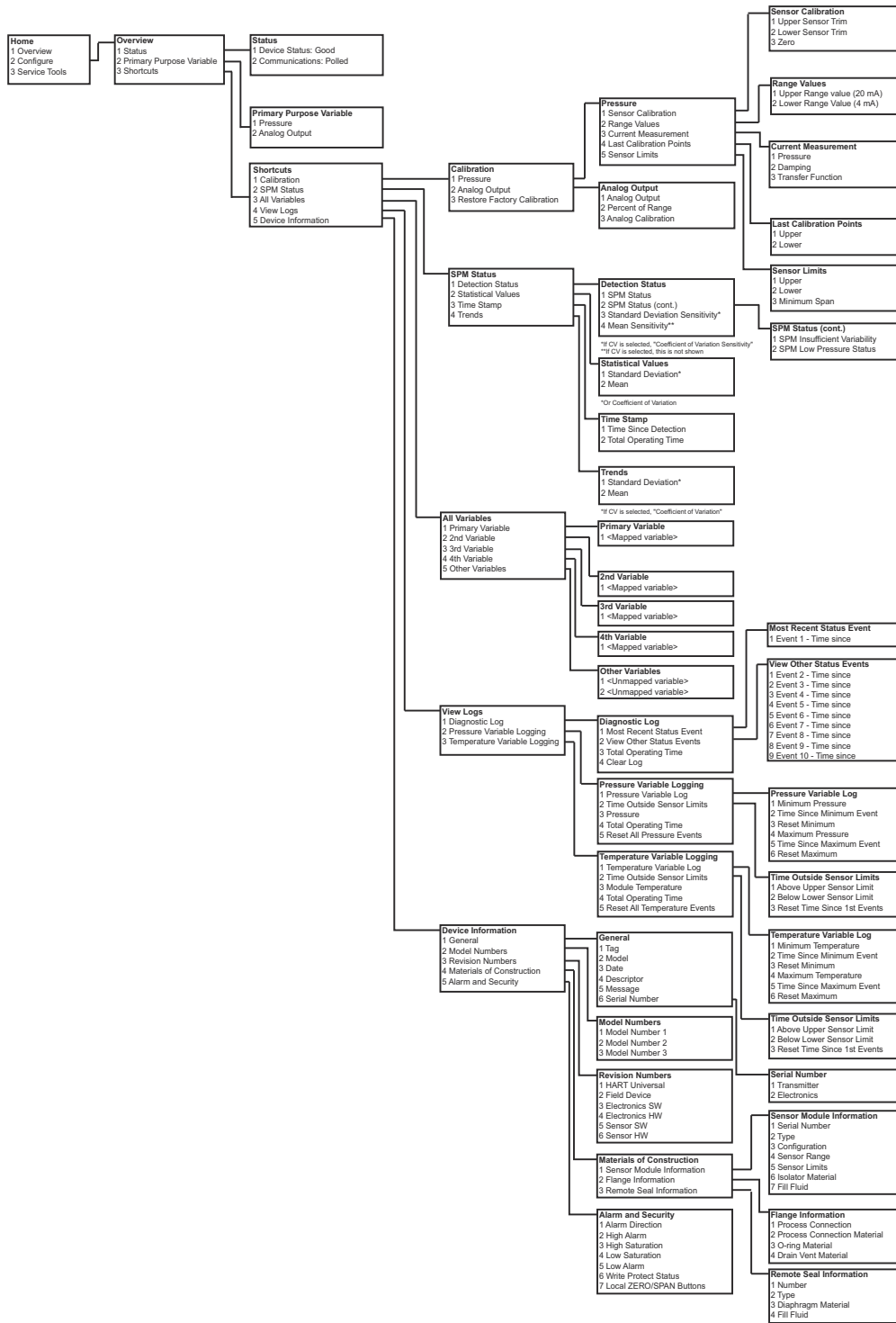

Figure 2-7: Configure (Guided Setup and Manual Setup)

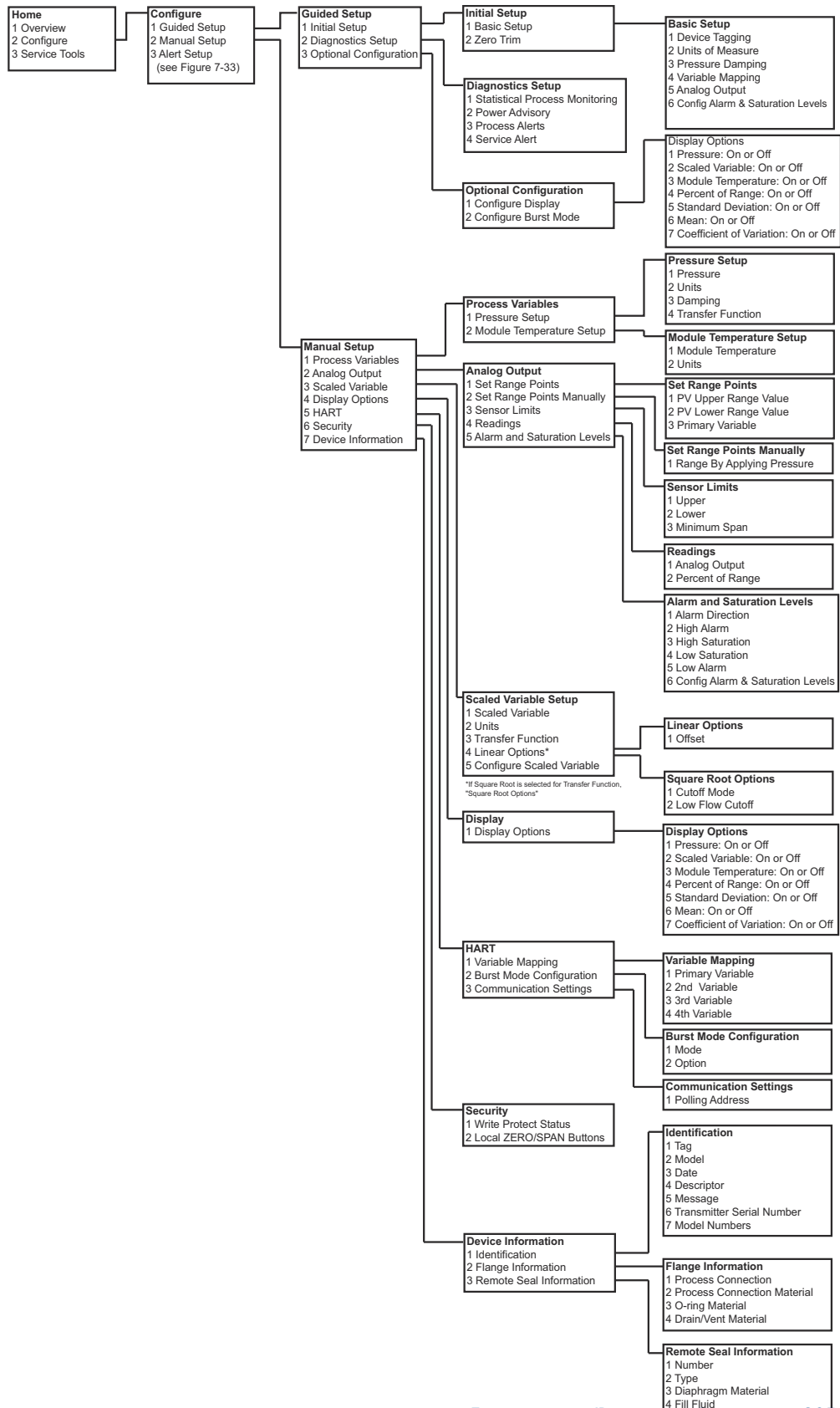

Figure 2-8: Configure (Alert Setup)

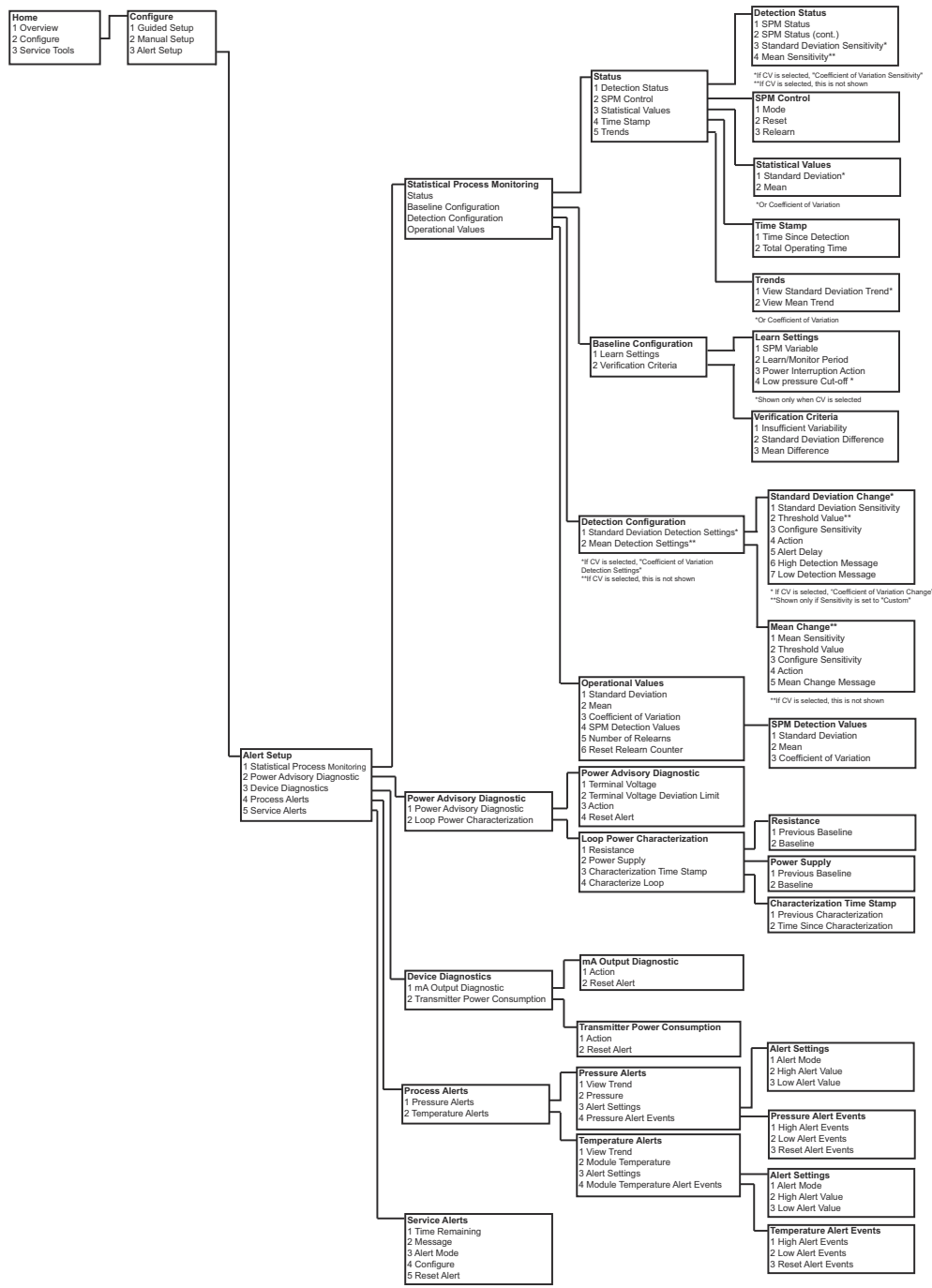
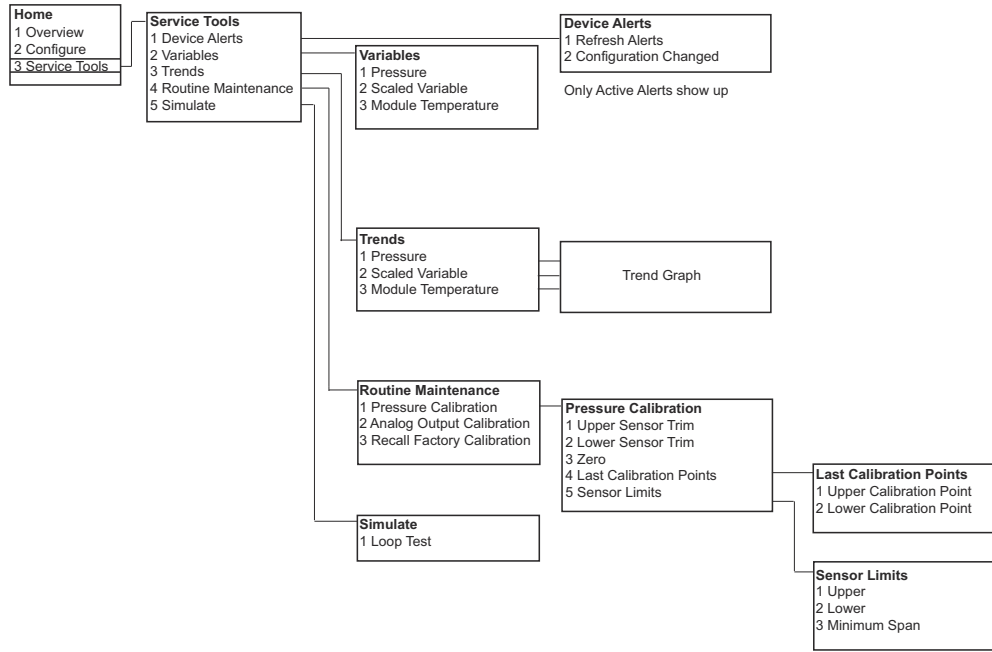

Figure 2-9: Service Tools



HART 7 menu trees

Figure 2-10: Overview

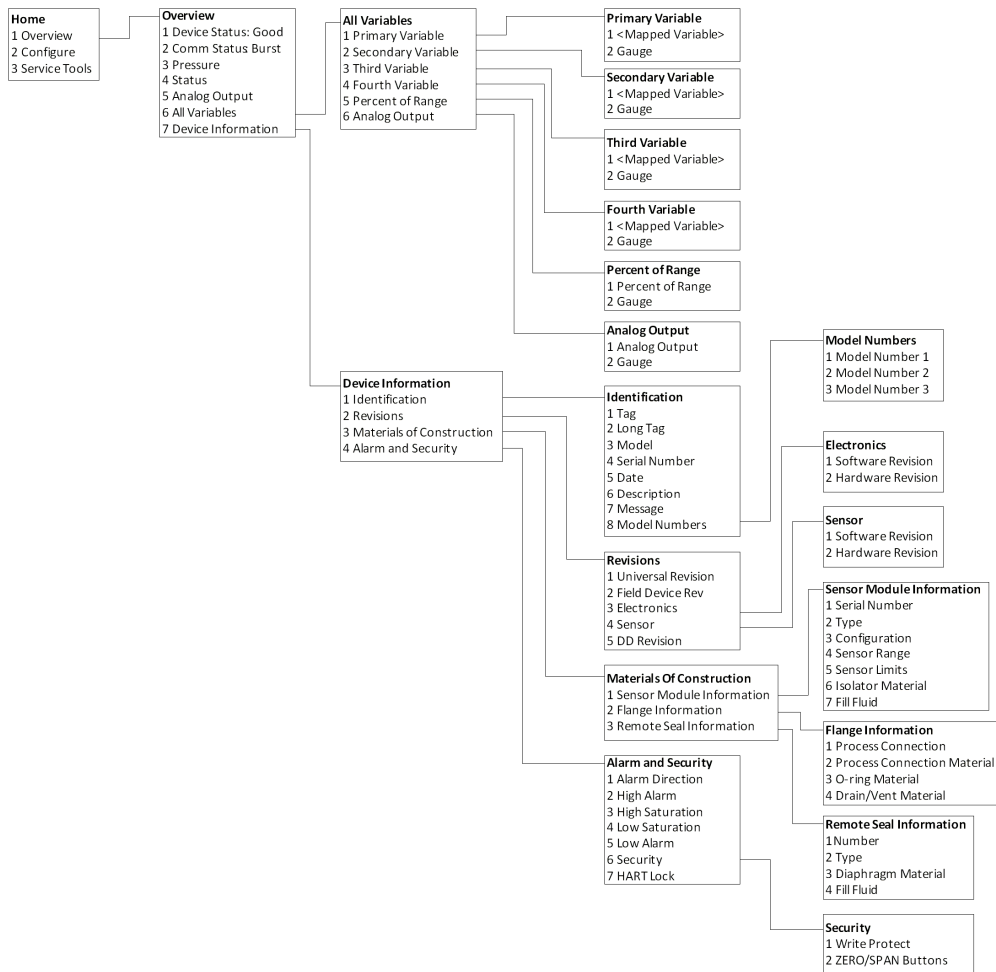

Figure 2-11: Configure (Guided Setup and Manual Setup)

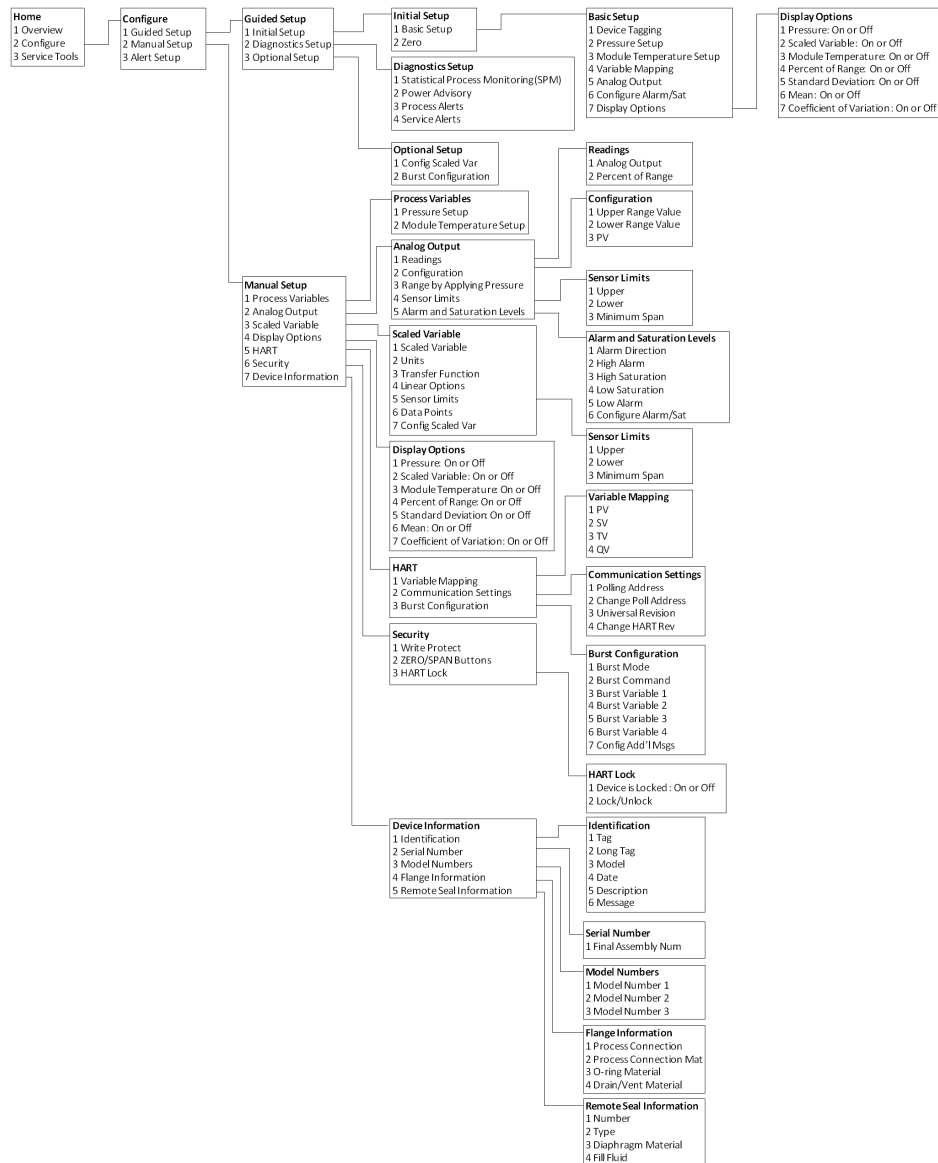

Figure 2-12: Configure (Alert Setup)

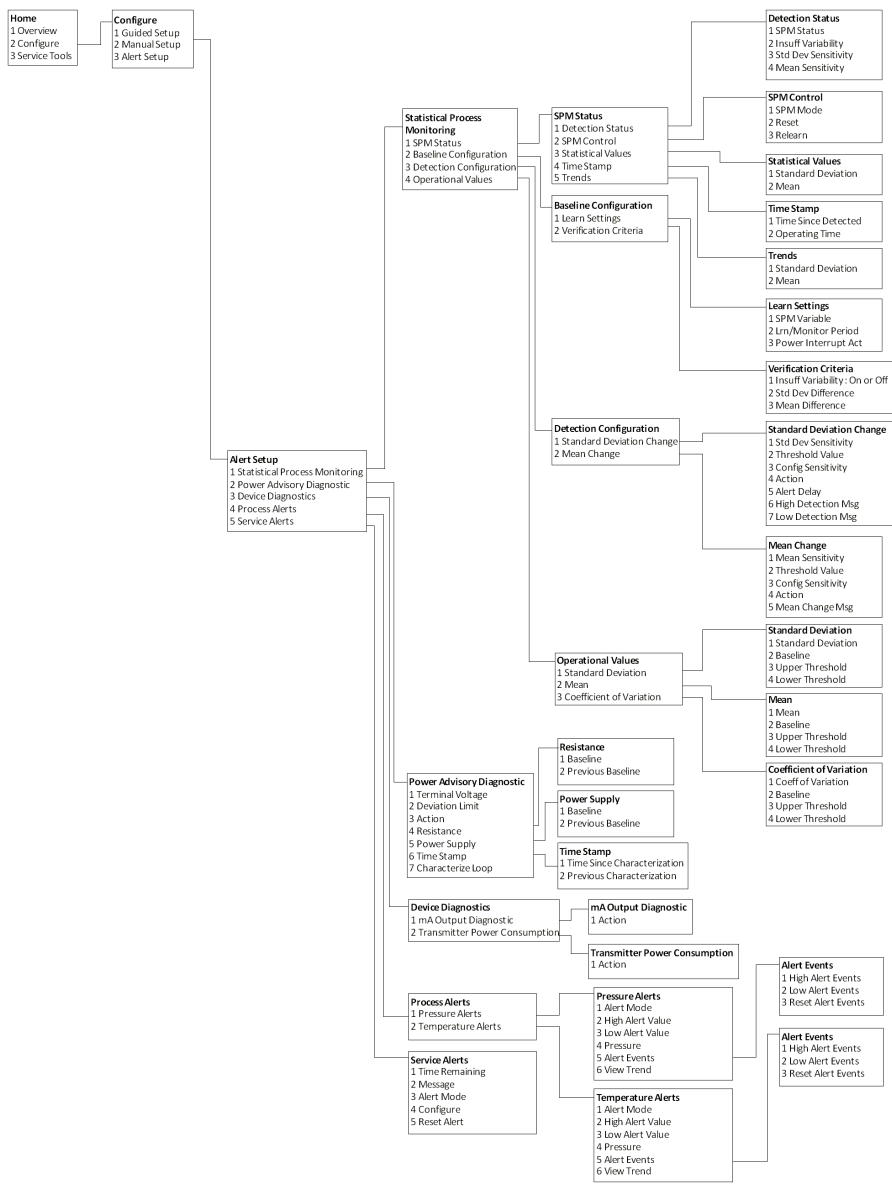
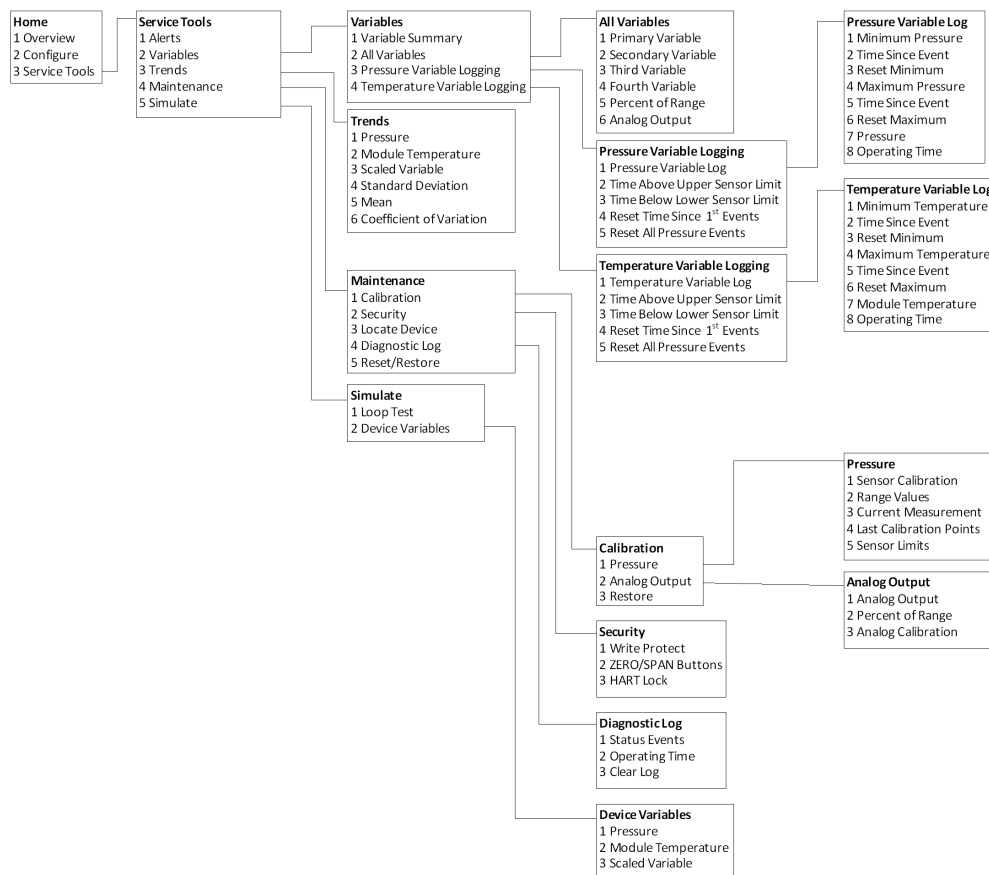

Figure 2-13: Service Tools



Device Dashboard Fast Key sequence

The following menu indicates Fast Key sequences for common functions. A check (✓) indicates the basic configuration parameters. At minimum, these parameters should be verified as part of the configuration and startup procedure.

	Function	Fast Key sequence
	Alarm and Saturation Levels	1, 4, 5
	Alarm Level Configuration	1, 7, 5
	Analog Output Alarm Direction	1, 7, 5, 1
	Burst Mode Control	2, 2, 4, 3
	Burst Option	2, 2, 4, 4
	Custom Display Configuration	2, 1, 3
✓	Damping	2, 2, 1, 5
	Date	2, 2, 5, 4

	Function	Fast Key sequence
	Descriptor	2, 2, 5, 5
	Digital to Analog Trim (4 - 20 mA Output)	3, 4, 2
	Disable Zero & Span Adjustment	2, 2, 7, 2
	Field Device Information	1, 7
	LCD Display Configuration	2, 2, 3
	Loop Test	3, 5, 1
	Lower Sensor Trim	3, 4, 1, 2
	Message	2, 2, 5, 6
	Module Temperature/Trend	3, 3, 3
	Poll Address	1, 2, 2
	Pressure Alert Configuration	2, 3, 1
	Range Values	2, 2, 1, 3
	Re-mapping	2, 2, 4, 1
	Rerange - Keypad Input	1, 5
	Rerange with Keypad	2, 2, 1, 3
	Saturation Level Configuration	2, 2, 1, 7
	Scaled D/A Trim (4–20 mA Output)	3, 4, 2
	Scaled Variable Configuration	2, 2, 2
	Sensor Information (Materials of Construction)	1, 7, 3
	Sensor Trim	3, 4, 1
	Sensor Trim Points	3, 4, 1, 4
✓	Tag	2, 2, 5, 1
	Temperature Alert Configuration	2, 3, 2
✓	Transfer Function (Setting Output Type)	2, 2, 1, 4
	Transmitter Security (Write Protect)	2, 2, 7, 1
✓	Units (Process Variable)	2, 2, 1, 2
	Upper Sensor Trim	3, 4, 1, 1
	Zero Trim	3, 4, 1, 3

HART 5 with Diagnostics Fast Key sequence

The following menu indicates Fast Key sequences for common functions. A check (✓) indicates the basic configuration parameters. At minimum, these parameters should be verified as part of the configuration and startup procedure.

	Function	Fast Key sequence
	Alarm and Saturation Levels	2, 2, 2, 5
	Alarm Level Configuration	2, 1, 1, 1, 6
	Analog Output Alarm Direction	2, 2, 2, 5, 5, 1
	Burst Mode On/Off	2, 2, 5, 2, 1

	Function	Fast Key sequence
	Burst Option	2, 2, 5, 2, 2
	Damping	2, 2, 1, 1, 3
	Date	2, 2, 7, 1, 3
	Descriptor	2, 2, 7, 1, 4
	Digital to Analog Trim (4–20 mA Output)	3, 4, 1, 2, 3
	Field Device Information	1, 3, 5
	LCD Display Configuration	2, 2, 4
	Loop Test	3, 5
	Lower Sensor Trim	3, 4, 1, 1, 1, 2
	Message	2, 2, 7, 1, 5
	Module Temperature	2, 2, 1, 2
	Poll Address	2, 2, 5, 3, 1
	Pressure Alert Configuration	2, 3, 4, 1, 3
	Range Values	3, 4, 1, 1, 2
	Re-mapping	2, 2, 5, 1
	Rerange - Keypad Input	2, 2, 2, 1
	Rerange with Pressure Source	2, 2, 2, 2
	Saturation Level Configuration	2, 1, 1, 1, 1, 6
	Scaled Variable Configuration	2, 2, 3, 5
	Sensor Information	1, 3, 5, 4, 1
	Sensor Trim Points	1, 3, 1, 1, 4
✓	Tag	2, 2, 7, 1, 1
	Temperature Alert Configuration	2, 3, 4, 2, 3
✓	Transfer Function (Setting Output Type)	2, 2, 1, 1, 4
	Transmitter Security (Write Protect)	1, 3, 5, 5, 6
✓	Units (Process Variable)	2, 2, 1, 1, 2
	Upper Sensor Trim	3, 4, 1, 1, 1, 1
	Zero Trim	3, 4, 1, 1, 1, 3

HART 7 Fast Key sequence

Function	Fast Key sequence
Alarm and Saturation Levels	2, 2, 2, 5
Alarm Level Configuration	2, 2, 2, 5, 6
Analog Output Alarm Direction	2, 2, 2, 5, 1
Burst Mode Control	2, 2, 5, 3
Burst Option	2, 2, 5, 3, 1
Damping	2, 2, 1, 1, 3

Function	Fast Key sequence
Date	2, 2, 5, 4
Descriptor	2, 2, 7, 1, 4
Digital to Analog Trim (4–20 mA Output)	3, 4, 1, 2, 3, 1
Disable Zero & Span Adjustment	2, 2, 6, 4
Field Device Information	1, 7
LCD Display Configuration	2, 2, 4
Loop Test	3, 5, 1
Lower Sensor Trim	3, 4, 1, 2
Message	2, 2, 7, 1, 6
Module Temperature/Trend	3, 3, 2
Poll Address	2, 2, 5, 2, 1
Pressure Alert Configuration	2, 3, 4, 1
Range Values	2, 2, 2, 2
Re-mapping	2, 2, 5, 1
Rerange - Keypad Input	2, 2, 2, 2, 1
Rerange with Keypad	2, 2, 2, 3
Saturation Level Configuration	2, 2, 2, 5, 6
Scaled D/A Trim (4–20 mA Output)	3, 4, 1, 2, 3, 2
Scaled Variable Configuration	2, 2, 3, 7
Sensor Information (Materials of Construction)	1, 7, 3, 1
Sensor Trim	3, 4, 1, 1, 1
Sensor Trim Points	3, 4, 1, 1, 4
Tag	2, 2, 7, 1, 1
Temperature Alert Configuration	2, 3, 4, 2
Transfer Function (Setting Output Type)	2, 2, 3, 3
Transmitter Security (Write Protect)	1, 7, 4, 6, 1
Units (Process Variable)	2, 2, 1, 1, 2
Upper Sensor Trim	3, 4, 1, 1
Zero Trim	3, 4, 1, 3

2.5 Check output

Before performing other transmitter online operations, review the digital output parameters to ensure that the transmitter is operating properly and is configured to the appropriate process variables.

2.5.1 Process variables

The process variables for the Rosemount 3051S provide transmitter output, and are continuously updated. The pressure reading in both engineering units and percent of

range will continue to track with pressures outside of the defined range from the lower to the upper range limit of the SuperModule™.

View process variables on the Field Communicator

Table 2-1: Field Communicator Fast Key sequences

Device Dashboard Fast Keys	3, 2
HART 5 with Diagnostics Fast Keys	3, 2, 1
HART 7 Fast Keys	3, 2, 2

Enter the Fast Key sequence process variables to view the process variables.

Note

Regardless of the range points, the 3051S will measure and report all readings within the digital limits of the sensor. For example, if the 4 and 20 mA points are set to 0 and 10 inH₂O, and the transmitter detects a pressure of 25 inH₂O, it digitally outputs the 25 inH₂O reading and a 250 percent of span reading.

View Process Variables on the AMS Device Manager

Procedure

1. Right click on the device and select **Overview** from the menu.
2. Select **All Variables** to display the primary, secondary, tertiary, and quaternary variables.

2.5.2 Module temperature

The Rosemount 3051S contains a temperature sensor near the pressure sensor in the SuperModule™. When reading this temperature, keep in mind module temperature is not a process temperature reading.

View the Module Temperature reading on the Field Communicator

Table 2-2: Field Communicator Fast Key Sequences

Device Dashboard Fast Keys	3, 2, 3
HART 5 with Diagnostics Fast Keys	3, 2, 1, 2
HART 7 Fast Keys	3, 2, 2, 2

Enter the Fast Key sequence Module Temperature to view the module temperature reading.

View the Module Temperature reading on the AMS Device Manager

Procedure

1. Right click on the device and select **Overview** from the menu.
2. Click **All Variables**.

2.6 Basic setup

2.6.1 Set Process Variable Units

The **PV Unit** command sets the process variable units to allow you to monitor your process using the appropriate units of measure.

Set Process Variable Units on the AMS Device Manager

Procedure

1. Right click on the device and select **Configure** from the menu.
2. Select **Manual Setup** from the left window pane.
3. Select the **Process Variables** tab.
4. Click the **Unit** drop-down menu to select units.

2.6.2 Set output (transfer function)

The Rosemount 3051S has two output settings: **linear** and **square root**. Activate the square root output option to make analog output proportional to flow. As input approaches zero, the pressure transmitter automatically switches to linear output in order to ensure a more smooth, stable output near zero (see [Figure 2-14](#)).

From 0 to 0.6 percent of the ranged pressure input, the slope of the curve is unity ($y = x$). This allows accurate calibration near zero. Greater slopes would cause large changes in output (for small changes at input). From 0.6 to 0.8 percent, curve slope equals 42 ($y = 42x$) to achieve continuous transition from linear to square root at the transition point.

Note

If low flow cutoff configuration is desired, use [Scaled variable configuration](#) to configure square root and [Remapping](#) to map the scaled variable as the primary variable.

Note

If scaled variable is mapped as the primary variable and square root mode is selected, ensure that transfer function is set to linear. Do not set the transfer function to square root if square root mode is selected for the primary variable, as this would cause the square root function to be performed twice.

Set Output on the Field Communicator

Device Dashboard Fast Keys	2, 2, 1, 4
HART 5 with Diagnostics Fast Keys	2, 2, 1, 1, 4
HART 7 Fast Keys	2, 2, 1, 1, 4

Procedure

1. Enter the Fast Key sequence for **Set Output (Transfer Function)**.
2. Select **Send**.

Set the Output on the AMS Device Manager

Procedure

1. Right click on the device and select **Configure** from the menu.

2. Select **Manual Setup** from the left window pane.
3. Select the **Process Variables** tab.
4. Select the **Transfer Function** drop-down menu to select output.

Figure 2-14: Square Root Output Transition Point

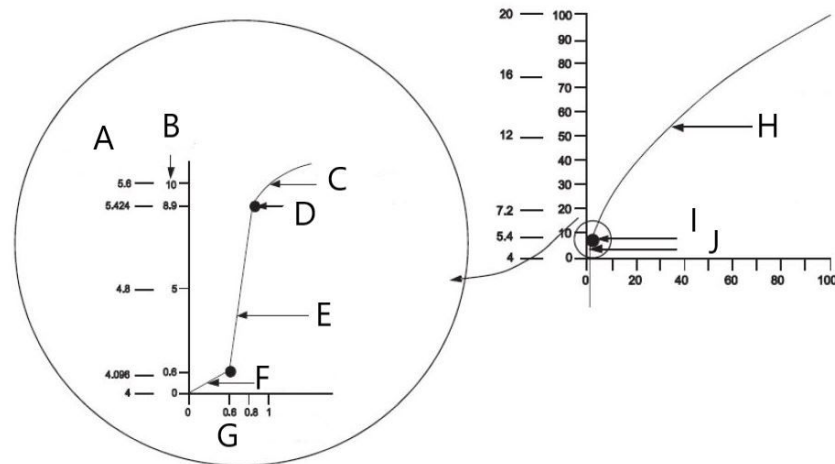

- A. Full scale output (mA DC)
- B. Full scale flow (%)
- C. Square root curve
- D. Transition point
- E. Slope = 42
- F. Slope = 1
- G. Pressure input
- H. Sq. root curve
- I. Transition point
- J. Linear section

Note

For a flow turn down of greater than 10:1, it is not recommended to perform a square root extraction in the transmitter. Instead, perform the square root extraction in the system. Alternatively, you can configure scaled variable for square root output. This configuration allows you to select a low flow cutoff value, which will work best for the application. If low flow cutoff configuration is desired, use [Scaled variable configuration](#) to configure square root and [Remapping](#) to map scaled variable as the primary variable.

2.6.3 Rerange

The **Range Values** command sets each of the lower and upper range analog values (4 and 20 mA points) to a pressure. The lower range point represents 0 percent of range and the upper range point represents 100 percent of range. In practice, the transmitter range values may be changed as often as necessary to reflect changing process requirements. For a complete listing of range and sensor limits, refer to the Specifications section of the [Rosemount 3051S Series of Instrumentation Product Data Sheet](#).

Note

Transmitters are shipped from Emerson fully calibrated per request or by the factory default of full scale (zero to upper range limit.)

Select from one of the methods below to rerange the transmitter. Each method is unique; examine all options closely before deciding which method works best for your process.

- Rerange with a Field Communicator or AMS Device Manager only.
- Rerange with a pressure input source and a Field Communicator or AMS Device Manager.
- Rerange with a pressure input source and the local zero and span buttons (option D1).

Note

If the transmitter security jumper/switch is **ON**, adjustments to the zero and span cannot be made. Refer to [Wiring the device](#) for security information.

Rerange with a Field Communicator or AMS Device Manager only

The easiest and most popular way to rerange is to use the Field Communicator only. This method changes the range values of the analog 4 and 20 mA points independently without a pressure input. This means that when you change either the 4 or 20 mA setting, you also change the span.

An example for the 4–20 mA HART output:

If the transmitter is ranged so that

4 mA = 0 inH₂O, and 20 mA = 100 inH₂O,

and you change the 4 mA setting to 50 inH₂O using the communicator only, the new settings are:

4 mA = 50 inH₂O, and 20 mA = 100.

Note that the span was also changed from 100 inH₂O to 50 inH₂O, while the 20 mA setpoint remained at 100 inH₂O.

To obtain reverse output, simply set the 4 mA point at a greater numerical value than the 20 mA point. Using the above example, setting the 4 mA point at 100 inH₂O and the 20 mA point at 0 inH₂O will result in reverse output.

Rerange on Field Communicators

Device Dashboard Fast Keys	1, 5
HART 5 with Diagnostics Fast Keys	2, 2, 2, 1
HART 7 Fast Keys	2, 2, 2, 4

From the **HOME** screen, enter the Fast Key sequence **Rerange with a Field Communicator Only**.

Procedure

1. From **Keypad Input**, select **2** and use the keypad to enter lower range value.
2. From **Keypad Input**, select **1** and use the keypad to enter upper range value.
3. To complete reranging the transmitter, select **Send**.

Rerange on AMS Device Manager

Procedure

1. Right click on the device and select **Configure** from the menu.
2. Select **Manual Setup** from the left window pane.
3. In the **Analog Output** tab, locate the **Configuration** box and perform the following procedure:
 - a) Enter the lower range value (LRV) and the upper range value (URV) in the fields provided.
 - b) Select **Send**.
 - c) After carefully reading the warning provided, select **Yes**.

Rerange with a Pressure Input Source and a Field Communicator or AMS Device Manager

Reranging using the Field Communicator and applied pressure is a way of reranging the transmitter when specific 4 and 20 mA points are not calculated.

Note

The span is maintained when the 4 mA point is set. The span changes when the 20 mA point is set. If the lower range point is set to a value that causes the upper range point to exceed the sensor limit, the upper range point is automatically set to the sensor limit, and the span is adjusted accordingly.

Rerange with a Pressure Input Source and Field Communicator

Device Dashboard Fast Keys	2, 2, 1, 8
HART 5 with Diagnostics Fast Keys	2, 2, 2, 2, 1
HART 7 Fast Keys	2, 2, 2, 3

From the HOME screen, enter the Fast Key sequence **Rerange with a Pressure Input Source and a Field Communicator or AMS Device Manager**. Follow the on-screen instructions.

Rerange with a Pressure Input Source and AMS Device Manager

Procedure

1. Right click on the device, select **Calibrate**, then **Apply Values** from the menu.
2. After the control loop is set to manual, select **Next**.
3. From the Apply Values menu, follow the online instructions to configure lower and upper range values.
4. Select **Exit** to leave the Apply Values screen.
5. Select **Next** to acknowledge the loop can be returned to automatic control.
6. Select **Finish** to acknowledge the method is complete.

Rerange with a Pressure Input Source and the local zero and span buttons (option D1)

Reranging using the local zero and span adjustments and a pressure source is a way of reranging the transmitter when specific 4 and 20 mA points are not known and a communicator is not available.

Note

The span is maintained when the 4 mA point is set. The span changes when the 20 mA point is set. If the lower range point is set to a value that causes the upper range point to exceed the sensor limit, the upper range point is automatically set to the sensor limit, and the span is adjusted accordingly.

To rerange the transmitter using the span and zero buttons, perform the following procedure:

Procedure

1. Using a pressure source with an accuracy at least four times the desired calibrated accuracy, apply a pressure equivalent to the lower range value to the high side of the transmitter.
 2. Push and hold the zero adjustment button for at least two seconds but no longer than 10 seconds.
 3. Apply a pressure equivalent to the upper range value to the high side of the transmitter.
 4. Push and hold the span adjustment button for at least two seconds but no longer than 10 seconds.
-

Figure 2-15: Plantweb™

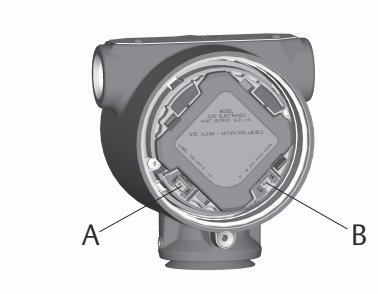

- A. Zero
 - B. Span
-

Figure 2-16: Junction box

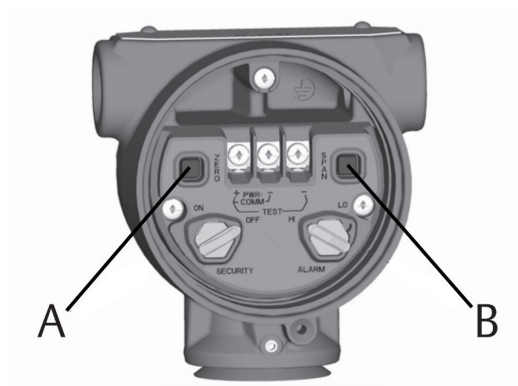

- A. Zero
 - B. Span
-

2.6.4 Damping

Damping changes the response time of the transmitter; higher values can smooth variations in output readings caused by rapid input changes. Determine the appropriate damp setting based on the necessary response time, signal stability, and other requirements of the loop dynamics of your system. The damping value of your device is user selectable from 0 to 60 seconds.

Access Damping on the Field Communicator

Device Dashboard Fast Keys	2, 2, 1, 5
HART 5 with Diagnostics Fast Keys	2, 2, 1, 1, 3
HART 7 Fast Keys	2, 2, 1, 1, 3

Enter the Fast Key sequence Damping.

Set the Damping Value in AMS Device Manager

Procedure

1. Right click on the device and select **Configure** from the menu.
2. Select **Manual Setup** from the left window pane.
3. In the Process Variables tab, locate **Damping** and set to desired value.

2.7 LCD display (Optional Order Code)

The LCD display connects directly to the interface/electronics board which maintains direct access to the signal terminals. The display indicates output and abbreviated diagnostic messages. A display cover is provided to accommodate the display.

The LCD display features a four-line display and a 0–100 percent scaled bar graph. The first line of five characters displays the output description, the second line of seven digits displays the actual value, the third line of six characters displays engineering units and the fourth line displays **ERROR** when the transmitter is in alarm. The LCD display can also display diagnostic messages.

The LCD display configuration command allows customization of the LCD display to suit application requirements. The LCD display will alternate between the selected items.

2.7.1 Configure the LCD display on the Field Communicator

Device Dashboard Fast Keys	2, 2, 3
HART 5 with Diagnostics Fast Keys	2, 2, 4
HART 7 Fast Keys	2, 2, 4

To configure the LCD display, enter the Fast Key sequence.

2.7.2 Configure the LCD display in AMS Device Manager

Procedure

1. Right click on the device and select **Configure** from the menu.

2. Select **Manual Setup** from the left window pane.
3. In the **Display** tab, select which parameters to show.

2.8 Detailed setup

2.8.1 Failure mode alarm and saturation

Rosemount 3051S Transmitters automatically and continuously perform self-diagnostic routines. If the self-diagnostic routines detect a failure, the transmitter drives the output to configured alarm values. The transmitter will also drive the output to configured saturation values if the applied pressure goes outside the 4–20 mA range values.

The transmitter will drive its output low or high based on the position of the alarm switch. See [Wiring the device](#).

Note

The failure mode alarm direction can also be configured using the Field Communicator or AMS Device Manager if hardware switches are not present. See [Alarm and saturation level configuration](#).

3051S Transmitters have three configurable options for failure mode alarm and saturation levels:

Table 2-3: Rosemount (Standard) Alarm and Saturation Values

Level	4–20 mA saturation	4–20 mA alarm
Low	3.9 mA	≤ 3.75 mA
High	20.8 mA	≥ 21.75 mA

Table 2-4: NAMUR-Compliant Alarm and Saturation Values

Level	4–20 mA saturation	4–20 mA alarm
Low	3.8 mA	≤ 3.6 mA
High	20.5 mA	≥ 22.5 mA

Table 2-5: Custom Alarm and Saturation Values

Level	4–20 mA saturation	4–20 mA alarm
Low	3.7 — 3.9 mA	3.4 — 3.8 mA
High	20.1 — 21.5 mA	20.2 — 23.0 mA

Per [Table 2-5](#), custom alarm and saturation levels can be configured between 3.4 and 3.9 mA for low values and between 20.1 and 23.0 mA for high values. The following limitations exist for custom levels:

- Low alarm level must be less than the low saturation level
- High alarm level must be higher than the high saturation level
- High saturation level must not exceed 21.5 mA
- Alarm and saturation levels must be separated by at least 0.1 mA

The Field Communicator or AMS Device Manager will provide an error message if a configuration rule is violated.

2.8.2 Alarm and saturation level configuration

Configure Alarm and Saturation Levels with a Field Communicator

Device Dashboard Fast Keys	2, 2, 1, 7
HART 5 with Diagnostics Fast Keys	2, 2, 2, 5
HART 7 Fast Keys	2, 2, 2, 5

Procedure

1. From the **HOME** screen, follow the Fast Key sequence.
2. To configure alarm levels, select **6: Config. Alarm and Sat. Levels**.
3. Select desired setting.
If **OTHER** is selected, enter **HI** and **LO** custom values.

Configure Alarm and Saturation Levels with AMS Device Manager

Procedure

1. Right click on the device and select **Configure** from the menu.
2. Select **Manual Setup** from the left window pane.
3. In the Analog Output tab, select **Configure Alarm and Saturation Levels**.
4. Follow instructions presented on the screen.

2.8.3 Alarm and saturation levels for burst mode

Transmitters set to burst mode handle saturation and alarm conditions differently.

Alarm conditions

- Analog output switches to alarm value
- Primary variable is burst with a status bit set
- Percent of range follows primary variable
- Temperature is burst with a status bit set

Saturation

- Analog output switches to saturation value
- Primary variable is burst normally
- Temperature is burst normally

2.8.4 Alarm and saturation values for multidrop mode

Transmitters set to multidrop mode handle saturation and alarm conditions differently.

- Alarm conditions**
- Primary variable is sent with a status bit set
 - Percent of range follows primary variable

- Module temperature is sent with a status bit set
- Saturation**
- Primary variable is sent normally
 - Temperature is sent normally

2.8.5 Alarm level verification

The transmitter alarm level should be verified before returning the transmitter to service if the following changes are made:

- Replacement of electronics board, SuperModule, or LCD display
- Alarm and saturation level configuration

This feature is also useful in testing the reaction of the control system to a transmitter in an alarm state. To verify the transmitter alarm values, perform a loop test, and set the transmitter output to the alarm value.

Related information

[Loop Test](#)

2.8.6 Process alerts

Process alerts allow the user to configure the transmitter to output a HART message when the configured data point is exceeded. Process Alerts can be set for pressure, module temperature, or both.

A process alert will be transmitted continuously if the pressure or module temperature set points are exceeded and the alert mode is **ON**. An alert will be displayed on a Field Communicator, AMS Device Manager status screen, and in the error section of the LCD display. The alert will reset once the value returns within range.

Note

HI alert value must be higher than the LO alert value. Both alert values must be within the pressure or module temperature sensor limits.

Configure the process alerts with a Field Communicator

Device Dashboard Fast Keys	2, 3
HART 5 with Diagnostics Fast Keys	2, 3, 4
HART 7 Fast Keys	2, 3, 4

Procedure

1. From the **HOME** screen, follow the Fast Key sequence **Process Alerts**.
2. To configure the process alerts, select an option:
 - To configure the pressure alerts, select **1, Pressure Alerts**
 - To configure the temperature alerts, select **2, Temperature Alerts**
 - a) To configure the high alert value, select **2, High Alert Value**
 - b) To configure the low alert value, select **3, Low Alert Value**
3. To enable changes, select **Send**.

Configure the Process Alerts with AMS Device Manager

Procedure

1. Right click on the device and select **Configure** from the menu.
2. Select **Alert Setup** from the left window pane and **Process Alerts** from the sub-menu.
3. In the Analog Output tab, enter **High Alert Value** and **Low Alert Value** to configure the pressure alerts.
4. Configure pressure alert mode using the drop-down menu.
5. Click **Send**.
6. In the Temperature Alerts tab, enter **High Alert Value** and **Low Alert Value** to configure the temperature alerts.
7. Configure temperature alert mode using the drop-down menu.
8. Click **Send**.

2.8.7 Scaled variable configuration

The scaled variable configuration allows the user to create a relationship/conversion between the pressure units and user-defined/custom units.

The scaled variable configuration defines the following items:

Scaled variable units	Custom units to be displayed
Scaled data options	Defines the transfer function for the application: <ul style="list-style-type: none"> • Linear • Square root
Pressure value position 1	Lower known value point (possible 4 mA point) with consideration of linear offset
Scaled variable value position 1	Custom unit equivalent to the lower known value point (lower known value point may or may not be the 4 mA point)
Pressure value position 2	Upper known value point (possible 20 mA point)
Scaled variable value position 2	Custom unit equivalent to the upper known value point (possible 20 mA point)
Linear offset	Value required to zero out pressures affecting the desired pressure reading
Low flow cutoff	Point at which output is driven to zero to prevent problems caused by process noise. It is highly recommended to use the low flow cutoff function in order to have a stable output and avoid problems due to process noise at a low flow or no flow condition. A low flow cutoff value that is practical for the flow element in the application should be entered.

Note

If Scaled Variable is mapped as the primary variable and square root mode is selected, ensure transfer function is set to linear. Refer to [Set output \(transfer function\)](#).

Configure with Field Communicator

Device Dashboard Fast Keys	2, 2, 2
----------------------------	---------

HART 5 with Diagnostics Fast Keys	2, 2, 3
HART 7 Fast Keys	2, 2, 3

Procedure

1. From the **HOME** screen, follow the Fast Key sequence **Scaled Variable Configuration**.
2. Select **SV Config** to configure scaled variable.
Units can be up to five characters long and include A-Z, 0-9, -, /, %, and *. Default unit is **DEFLT**. The first character is always an asterisk (*), which identifies the units displayed are scaled variable units.
3. Select **Scaled Data Options**.
 - a) Select **Linear** if the relationship between process variable and scaled Variable units is linear. Linear prompts for two data points, which results in four values to enter.
 - b) Select **Square Root** if the relationship between PV and scaled Variable is square root (flow applications). Square root will prompt for one data point, requiring two values to be entered.
4. Enter **Pressure Value Position 1**.
Pressure values must be within the range of the transmitter.
 - a) If performing a Linear Function, enter the lower known value point considering any linear offset.
 - b) If performing a Square Root Function, select **OK** to acknowledge pressure value is set to zero.
5. Enter **Scaled Variable Position 1**.
 - a) If performing a Linear Function, enter the lower known value point in terms of the scaled Variable; this value must be no longer than seven digits.
 - b) If performing a Square Root Function, select **OK** to acknowledge scaled variable value is set to zero.
6. Enter **Pressure Value Position 2**.
Pressure values must be within the range of the transmitter.
 - a) Enter the upper known value point in terms of pressure.
7. Enter **Scaled Variable Position 2**.
 - a) If performing a Linear Function, enter custom unit equivalent to the upper known value point; this value must be no longer than seven digits.
 - b) If performing a Square Root Function, enter the maximum scaled Variable unit that is equated to the high pressure from [Step 6](#); this value must be no longer than seven digits. Skip to Step 9.
8. If performing a Linear Function, enter linear offset value in pressure units. Skip to Step 10.
9. If performing a Square Root Function, enter **Low Flow Cutoff** mode.
 - a) If a low flow cutoff value is not desired, select **OFF**.
 - b) If a low flow cutoff value is desired, select **ON** and enter this value in scaled variable (custom) units on the next screen.

- To acknowledge that the loop can be returned to automatic control, select **OK**.

Configure the Scaled Variable with AMS Device Manager

Procedure

- Right click on the device and select **Configure** from the menu.
- Select **Manual Setup** from the left window pane.
- In the Scaled Variable tab, select **Configure Scaled Variable**.
- Follow instructions presented on the screen.

2.8.8 Differential pressure level example scaled variable

Below is an example of scaled variable in a DP level application. The Rosemount 3051S reads the DP in units of inH₂O, but the output scaled variable is the height of the liquid in the tank in inches.

Figure 2-17: Example Tank

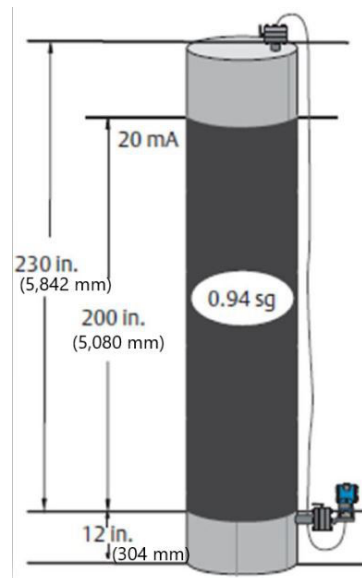

Note

Dimensions are in inches (mm).

A differential transmitter is used in a level application where the span is 188 inH₂O (200-in. 0.94 sg). Once installed on an empty tank and taps vented, the process variable reading is -209.4 inH₂O. The process variable reading is the head pressure created by fill fluid in the capillary. Based on Figure 2-15, the scaled variable configuration would be as follows:

Scaled variable units	Inches
Scaled data options	Linear
Pressure value position 1	0 inH ₂ O (0 mbar)
Scaled variable position 1	12 in. (305 mm)
Pressure value position 2	188 inH ₂ O (0.47 bar)
Scaled Variable Position 2	212 in. (5385 mm)

Linear offset -209.4 inH2O (-0.52 bar)

2.8.9 Differential pressure flow example of scaled variable

This DP Flow example of scaled variable takes the DP reading of inH2O, and outputs the resulting flow in gal/h. Output is scaled with a square root operation internally. The DP transmitter is used in conjunction with an orifice plate in a flow application where the differential pressure at full scale flow is 125 inH2O. In this particular application, the flow rate at full scale flow is 20,000 gallons of water per hour. Emerson highly recommends using the low flow cutoff function in order to have a stable output and avoid problems due to process noise at a low flow or no flow condition. A low flow cutoff value that is practical for the flow element in the application should be entered. In this particular example, the low flow cutoff value is 1000 gallons of water per hour. Based on this information, the Scaled Variable configuration would be as follows:

Scaled variable units:	gal/h
Scaled data options:	Square root
Pressure value Position 2:	125 inH2O (311 mbar)
Scaled variable position 2:	20,000 gal/h (75,708 lt/hr)
Low flow cutoff:	1000 gal/h (ON)

Note

Pressure Value Position 1 and Scaled Variable Position 1 are always set to zero for a flow application. No configuration of these values is required.

2.8.10 Remapping

The remapping function allows the transmitter primary, secondary, tertiary, and quaternary variables to be configured as desired.

Table 2-6: Default Configuration for Transmitter Variables

	HART 5	HART 5 with Diagnostics	HART 7
Primary Variable (PV)	Pressure		
Secondary Variable (SV)	Module Temperature		
Tertiary Variable (TV)	Scaled Variable	Standard Deviation	Scaled Variable
Quaternary Variable (QV)		Coefficient of Variation	Standard Deviation

Note

The variable assigned as the primary variable drives the 4–20 mA analog output. The scaled variable can be remapped as the primary variable if desired.

Remapping with a Field Communicator

Device Dashboard Fast Keys	2, 2, 4, 1
HART 5 with Diagnostics Fast Keys	2, 2, 5, 1
HART 7 Fast Keys	2, 2, 5, 1

Procedure

1. From the **Home** screen, enter the Fast Key sequence Remapping.
2. Set the control loop to **Manual** (see [Setting the loop to Manual](#)).
3. Select desired primary variable and select **Enter**.
4. Select desired secondary variable and select **Enter**.
5. If using 3051S HART 5 with Diagnostics or 3051S with HART 7, select desired quaternary variable and select Enter. If using 3051S with HART 5, continue to Step 6.
6. Select **Send** to complete the changes, then return the loop to automatic control.
7. Select **OK** to acknowledge that the loop can be returned to automatic control.

Re-mapping with the AMS Device Manager

Procedure

1. Set the control loop to manual (see [Setting the loop to Manual](#)).
2. Right click on the device and select **Configure** from the menu.
3. Select **Manual Setup** from the left window pane.
4. In the HART tab, locate the **Variable Mapping** box.
5. Select desired primary variable.
6. Select desired secondary variable.
7. Select desired tertiary variable.
8. If using 3015A HART 5 with Diagnostics or 3051S with HART 7, select desired quaternary variable and select **Enter**. If using 3051S with HART 5, continue to Step 9.
9. Select **Send**.

2.8.11 Module temperature unit

The sensor temperature unit command selects between Celsius and Fahrenheit units for the module temperature.

Note

The module temperature output is accessible via HART only.

Configure the Module Temperature Unit on a Field Communicator

Device Dashboard Fast Keys	2, 2, 1, 6
HART 5 with Diagnostics Fast Keys	2, 2, 1, 2, 2
HART 7 Fast Keys	2, 2, 1, 2, 2

Enter the Fast Key sequence **Module Temperature Unit** and select **degC** for Celsius or **degF** for Fahrenheit.

Configure the Module Temperature Unit on a Field Communicator

Device Dashboard Fast Keys	2, 2, 1, 6
HART 5 with Diagnostics Fast Keys	2, 2, 1, 2, 2
HART 7 Fast Keys	2, 2, 1, 2, 2

Enter the Fast Key sequence **Module Temperature Unit** and select **degC** for Celsius or **degF** for Fahrenheit.

Configure the Module Temperature Unit on AMS Device Manager

Procedure

1. Right click on the device and select **Configure** from the menu.
2. Select **Manual Setup** from the left window pane.
3. In the Process Variables tab, locate the **Module Temperature Setup** box.
4. Use the Units drop-down menu to select **degF** (Fahrenheit) or **degC** (Celsius).
5. Select **Send**.

2.9 Diagnostics and service

Diagnostics and service functions listed below are primarily for use after field installation. The transmitter test feature is designed to verify that the transmitter is operating properly, and can be performed either on the bench or in the field. The loop test feature is designed to verify proper loop wiring and transmitter output, and should only be performed after you install the transmitter.

2.9.1 Loop Test

The Loop Test command verifies the output of the transmitter, the integrity of the loop, and the operations of any recorders or similar devices installed in the loop.

Initiate a Loop Test on a Field Communicator

Device Dashboard Fast Keys	3, 5, 1
HART 5 with Diagnostics Fast Keys	3, 5, 1
HART 7 Fast Keys	3, 5, 1

To initiate a Loop Test, perform the following procedure:

Procedure

1. Connect a reference meter to the transmitter by either connecting the meter to the test terminals on the terminal block, or shunting transmitter power through the meter at some point in the loop.
2. From the **Home** screen, enter the Fast Key sequence **Loop Test** to verify the output of the transmitter.
3. Select **OK** after the control loop is set to manual (see [Setting the loop to Manual](#)).
4. Select a discrete milliamp level for the transmitter to output. At the **CHOOSE ANALOG OUTPUT** prompt, select **1: 4mA**, **2: 20mA**, or **3: "Other"** to manually input a value.
 - a) If you are performing a Loop Test to verify the output of a transmitter, enter a value between 4 and 20 mA.
 - b) If you are performing a Loop Test to verify alarm levels, enter the milliamp value representing an alarm state (see Table 2-1, Table 2-2, and Table 2-3).

5. Check the reference meter installed in the test loop to verify it displays the commanded output value.
 - a) If the values match, the transmitter and the loop are configured and functioning properly.
 - b) If the values do not match, the current meter may be attached to the wrong loop, there may be a fault in the wiring, the transmitter may require an output trim, or the reference meter may be malfunctioning.

After completing the test procedure, the display returns to the loop test screen to choose another output value or to end loop testing.

Initiate a Loop Test on AMS Device Manager

Procedure

1. Right click on the device and select **Service Tools** from the menu.
2. Select **Simulate** from the left window pane.
3. In the Simulate tab, locate and select **Loop Test**.
4. Follow instructions presented on the screen.

2.9.2 Simulate Device Variables

It is possible to temporarily set the pressure, module temperature, or scaled variable to a user-defined fixed value for testing purposes. Once the simulated variable method is left, the process variable will be automatically returned to a live measurement. Simulate Device Variables is only available with HART Revision 7.

Simulate Device Variables on a Field Communicator

Device Dashboard Fast Keys	N/A
HART 5 with Diagnostics Fast Keys	N/A
HART 7 Fast Keys	3, 5, 2

From the HOME screen, enter the Fast Key sequence **Simulate digital signal with a Field Communicator**.

Simulate Device Variables on AMS Device Manager

Procedure

1. Right click on the device and select **Service Tools** from the menu.
2. Select **Simulate** from the left window pane.
3. Under **Device Variables** select a digital value to simulate.
 - **Pressure**
 - **Sensor Temperature**
 - **Scaled Variable**
4. Follow the screen prompts to simulate selected digital value.

2.10 Advanced functions

2.10.1 Saving, recalling, and cloning configuration data

Use the cloning feature of the Field Communicator or the AMS Device Manager User Configuration feature to configure several Rosemount 3051S Transmitters similarly. Cloning involves configuring a transmitter, saving the configuration data, and then sending a copy of the data to a separate transmitter. Several possible procedures exist when saving, recalling, and cloning configuration data or AMS Device Manager online guides.

Saving, Recalling, and Cloning Configuration Data on a Field Communicator

Device Dashboard Fast Keys	N/A
HART 5 with Diagnostics Fast Keys	left arrow, 1, 2
HART 7 Fast Keys	left arrow, 1, 2

Procedure

1. Confirm and apply configuration changes to the first transmitter.
2. Save the configuration data.

If transmitter configuration has not been modified, **SAVE** option will be disabled.

 - a) From the bottom of the Field Communicator screen, select **SAVE**.
 - b) Select to save your configuration on either the **Internal Flash (default)** or the **System Card**.
 - c) Enter the name for this configuration file.
 - d) Select **SAVE**.
3. Power the receiving transmitter and connect with the Field Communicator.
4. Access the HART Application menu by pressing the **left arrow** from the HOME/ ONLINE screen.
5. Locate the saved transmitter configuration file.
 - a) Select **Offline**.
 - b) Select **Saved Configuration**.
 - c) Select either **Internal Flash Contents** or **System Card Contents** depending on where the configuration was stored.
6. Use the **down arrow** to scroll through the list of configurations in the memory module, and use the **right arrow** to select and retrieve the desired configuration.
7. Select **Send** to transfer the configuration to the receiving transmitter.

The transmitter receiving cloned data must have the same software version (or later) as the original transmitter.
8. After the control loop is set to manual, select **OK**.
9. After the configuration has been sent, select **OK** to acknowledge that the loop can be returned to automatic control.

When finished, the Field Communicator informs you of the status. Repeat Step 3 through Step 9 to configure another transmitter.

Note

The transmitter receiving cloned data must have the same software version (or later) as the original transmitter.

Creating a Reusable Copy in AMS Device Manager

Create a reusable copy of a configuration.

Procedure

1. Completely configure the first transmitter.
2. Select **View**.
3. Select **User Configurations** from the menu (or select the toolbar button)
4. In the User Configurations window, right click and select **New** from the context menu.
5. In the New window, select a device from the list of templates shown, and select **OK**.
6. The template is copied into the User Configurations window with the tag name highlighted; rename it as appropriate and select **Enter**.
A device icon can also be copied by dragging and dropping a device template or any other device icon from Wireless Explorer or Device Connection View into the User Configurations window.
7. Right click on the copied device and select **Configure/Setup** from the User Configurations window.
8. Select **Compare** from the bottom left window pane.
9. Transfer values from the current configuration to the user configuration as appropriate or enter values by typing them into the available fields.
10. Select **Save** to apply the values.

Applying a User Configuration in AMS Device Manager

Any amount of User Configurations can be created for the application. They can also be saved, and applied to connected devices or to devices in the device list or plant database.

Note

When using AMS Device Manager Revision 6.0 or later, the device to which the user configuration is applied must be the same model type as the one created in the user configuration.

Procedure

1. In the **User Configurations** window, select the desired user configuration.
2. Drag the icon onto a like device in **Wireless Explorer** or **Device Connection View**. The **Compare Configurations** window opens, showing the parameters of the target device on one side and the parameters of the user configuration on the other.
3. Transfer parameters from the user configuration to the target device as desired. Select the **Transfer Multiple** button to send the configuration and close the window.

2.10.2 Burst mode

When configured for **Burst** mode, the Rosemount 3051S provides faster digital communication from the transmitter to the control system by eliminating the time required for the control system to request information from the transmitter. Burst mode is compatible with the analog signal. Because the HART protocol features simultaneous digital and analog data transmission, the analog value can drive other equipment in the

loop while the control system is receiving the digital information. Burst mode applies only to the transmission of dynamic data (pressure and module temperature in engineering units, pressure in percent of range, and/or analog output), and does not affect the way other transmitter data is accessed.

Access to information other than dynamic transmitter data is obtained through the normal poll/response method of HART communication. A Field Communicator, AMS Device Manager, or the control system may request any of the information that is normally available while the transmitter is in burst mode. Between each message sent by the transmitter, a short pause allows the Field Communicator, AMS Device Manager, or a control system to initiate a request. The transmitter will receive the request, process the response message, and then continue bursting the data approximately three times per second.

Selecting burst mode options in HART 5

Message content options:

- **PV only**
- **Percent of range/current**
- **PV, 2V, 3V, 4V**
- **Process variables**

Selecting burst mode options in HART 7

Message content options:

- **PV only**
- **Percent of range/current**
- **PV, 2V, 3V, 4V**
- **Process variables and status**
- **Process variables**
- **Device status**
- **All dynamic variables**

Selecting a HART 7 trigger mode

When in HART 7 mode, the following trigger modes can be selected.

- **Continuous (same as HART 5 burst mode)**
- **Rising**
- **Falling**
- **Windowed**
- **On change**

Note

Consult host system manufacturer for burst mode requirements.

Configure Burst Mode for Field Communicator

Enter the Fast Key sequence **Burst Mode** to configure the transmitter for burst mode.

Table 2-7:

Device Dashboard Fast Keys	2, 2, 4, 3
----------------------------	------------

Table 2-7: (continued)

HART 5 with Diagnostics Fast Keys	2, 2, 5, 2
HART 7 Fast Keys	2, 2, 5, 3

AMS Device Manager

1. Right click on the device and select **Configure** from the menu.
2. Select **Manual Setup** from the left window pane.
3. Select the **HART** tab.
4. Enter the configuration in **Burst Mode Configuration** fields.

2.11 Multidrop communication

Multidropping transmitters refers to the connection of several transmitters to a single communications transmission line. Communication between the host and the transmitters takes place digitally with the analog output of the transmitters deactivated.

Multidrop installation requires consideration of the update rate necessary from each transmitter, the combination of transmitter models, and the length of the transmission line. Communication with transmitters can be accomplished with Bell 202 modems and a host implementing HART protocol. Each transmitter is identified by a unique address and responds to the commands defined in the HART protocol. Field Communicators and AMS Device Manager can test, configure, and format a multidropped transmitter the same way as a transmitter in a standard point-to-point installation.

Note

A transmitter in multidrop mode has the analog output fixed at 4 mA. If a meter is installed to a transmitter in multidrop mode, it will alternate the display between current fixed and the specified meter output(s).

The Rosemount 3051S is set to address zero (0) at the factory, which allows operation in the standard point-to-point manner with a 4–20 mA output signal. To activate multidrop communication, the transmitter address must be changed to a number from 1 to 15 for HART Revision 5 or 1 to 63 for HART Revision 7. This change deactivates the 4–20 mA analog output, setting it to 4 mA. It also disables the failure mode alarm signal, which is controlled by the upscale/downscale switch/jumper position. Failure signals in multidropped transmitters are communicated through HART messages.

2.11.1 Changing a transmitter address

To activate multidrop communication, the transmitter poll address must be assigned a number from 1 to 15, and each transmitter in a multidropped loop must have a unique poll address.

Change a transmitter address with a Field Communicator

Device Dashboard Fast Keys	1, 2, 2
HART 5 with Diagnostics Fast Keys	2, 2, 5, 3, 1
HART 7 Fast Keys	2, 2, 5, 2, 1

Procedure

1. From the HOME screen, enter the Fast Key sequence **Changing a Transmitter Address** and select **OK**.
2. After removing loop from automatic control, select **OK** again and enter the address.

Change a transmitter address with AMS Device Manager

Procedure

1. Right click on the device and select **Configure** from the menu.
2. For HART Revision 5 devices:
 - a) Select **Manual Setup** and select the **HART** tab.
 - b) In the Communications Settings box, enter polling address in the Polling Address box. Select **Send**.
3. For HART Revision 7 devices:
 - a) Select **Manual Setup** and select the **HART** tab.
 - b) Select the **Change Polling Address** button and follow instructions presented on the screen.
4. Carefully read the warning and select **Yes** if it is safe to apply the changes.

2.11.2

Communicating with a multidropped transmitter

To communicate with a multidropped transmitter, the Field Communicator of AMS Device Manager has to be set up for polling.

Set up the Field Communicator for Polling

Device Dashboard Fast Keys	3, 1, 2
HART 5 with Diagnostics Fast Keys	Left arrow, 3, 1, 2
HART 7 Fast Keys	Left arrow, 3, 1, 2

Procedure

1. Select **Utility** and Configure HART Application.
2. Select **Polling Addresses**.
3. Enter a polling address.
 - For HART Revision 5 devices, enter address 0–15.
 - For HART Revision 7 devices, enter address 0–63.

Set up the AMS Device Manager for Polling

Procedure

1. Select the **HART modem** icon.
2. Select **Scan All Devices**.

3 Hardware Installation

3.1 Overview

The information in this section covers installation considerations for HART® Protocol. The [3051S Quick Start Guide](#) for HART is shipped with every transmitter to describe basic installation, wiring, and startup procedures. Dimensional drawings for each 3051S Pressure Transmitter variation and mounting configuration are included in the [3051S Series of Instrumentation Product Data Sheet](#).

Note

The following sections contain installation instructions for many optional features. Only follow a section's directions if the transmitter being installed comes with the features described.

3.2 Considerations

3.2.1 Installation considerations

Measurement performance depends upon proper installation of the transmitter and impulse piping. Mount the transmitter close to the process and use minimum piping to achieve best performance. Also, consider the need for easy access, personnel safety, practical field calibration, and a suitable transmitter environment. Install the transmitter to minimize vibration, shock, and temperature fluctuation.

NOTICE

Install the enclosed pipe plug in the unused conduit opening. For straight threads, a minimum of six threads must be engaged. For tapered threads, install the plug wrench-tight. For material compatibility considerations, see [Material Selection and Compatibility Considerations for Rosemount Pressure Transmitters](#).

3.2.2 Environmental considerations

Best practice is to mount the transmitter in an environment that has minimal ambient temperature change. The transmitter electronics temperature operating limits are -40 to 185 °F (-40 to 85 °C). Refer to [Rosemount 3051S Series of Instrumentation Product Data Sheet](#), which lists the sensing element operating limits. Mount the transmitter so that it is not susceptible to vibration and mechanical shock and does not have external contact with corrosive materials.

3.2.3 Mechanical considerations

Access requirements and cover installation can help optimize transmitter performance. See the [Rosemount 3051S Series of Instrumentation Product Data Sheet](#) for temperature operating limits.

NOTICE

Ensure the transmitter is securely mounted. Tilting of the transmitter may cause a zero shift in the transmitter output.

Side mounted

When the transmitter is mounted on its side, position the Coplanar™ flange to ensure proper venting or draining. Mount the flange as shown in [Figure 3-1](#) and [Figure 3-4](#) keeping drain/vent connections on the bottom for gas service and on the top for liquid service.

Figure 3-1: Coplanar Installation Example: Liquid service

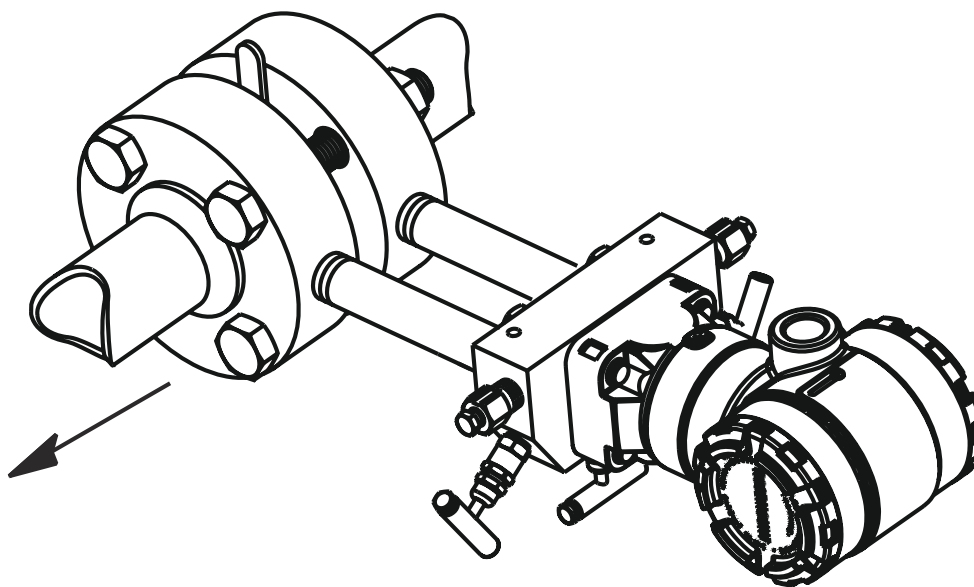
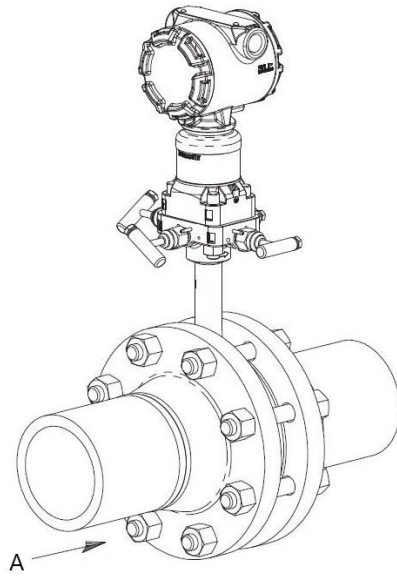
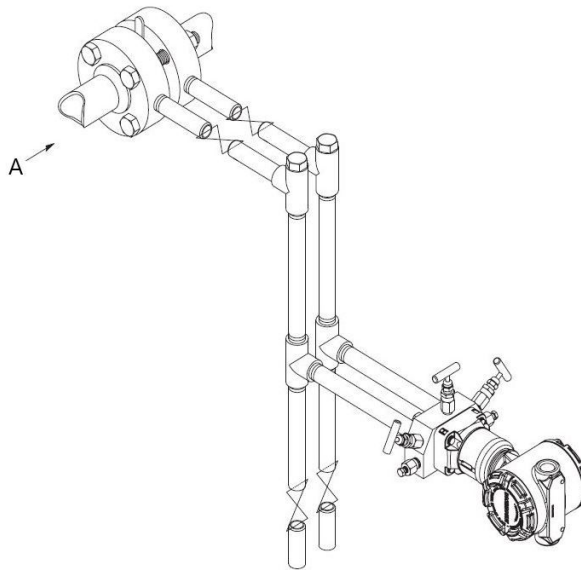

Figure 3-2: Coplanar Installation Example: Gas service



A. Flow

Figure 3-3: Coplanar Installation Example: Steam service



A. Flow

Figure 3-4: Inline Installation Example: Liquid service

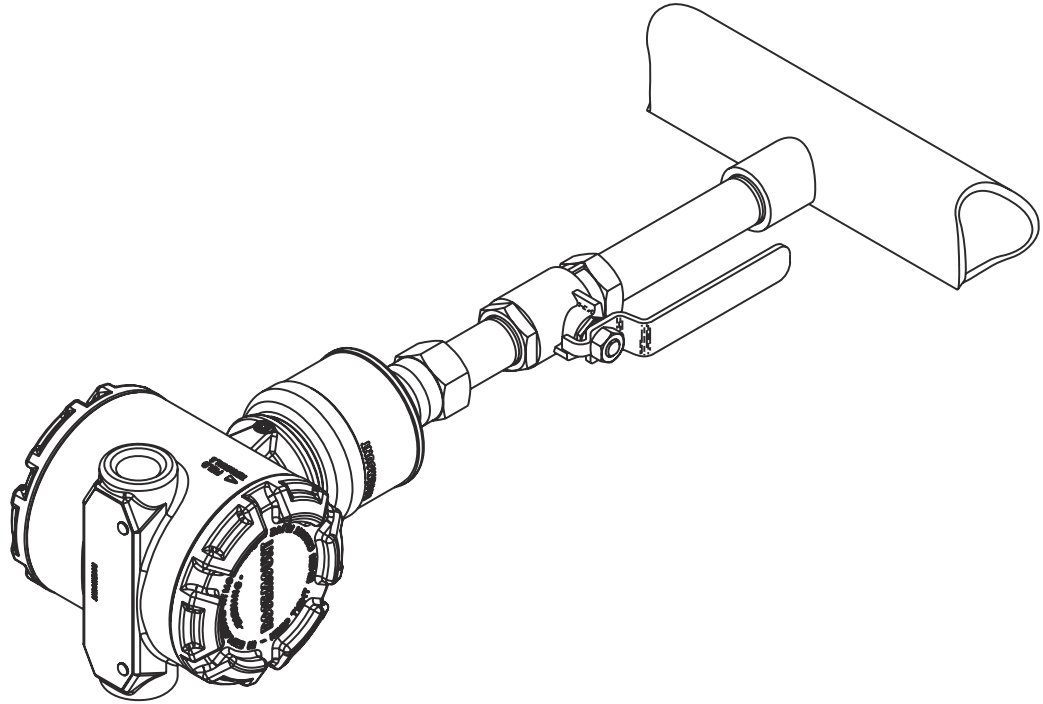

Figure 3-5: Inline Installation Example: Gas service

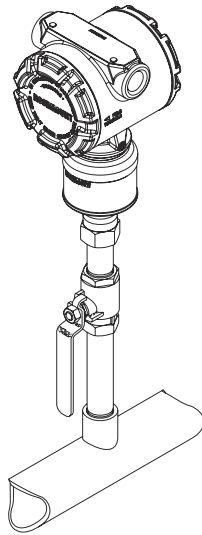
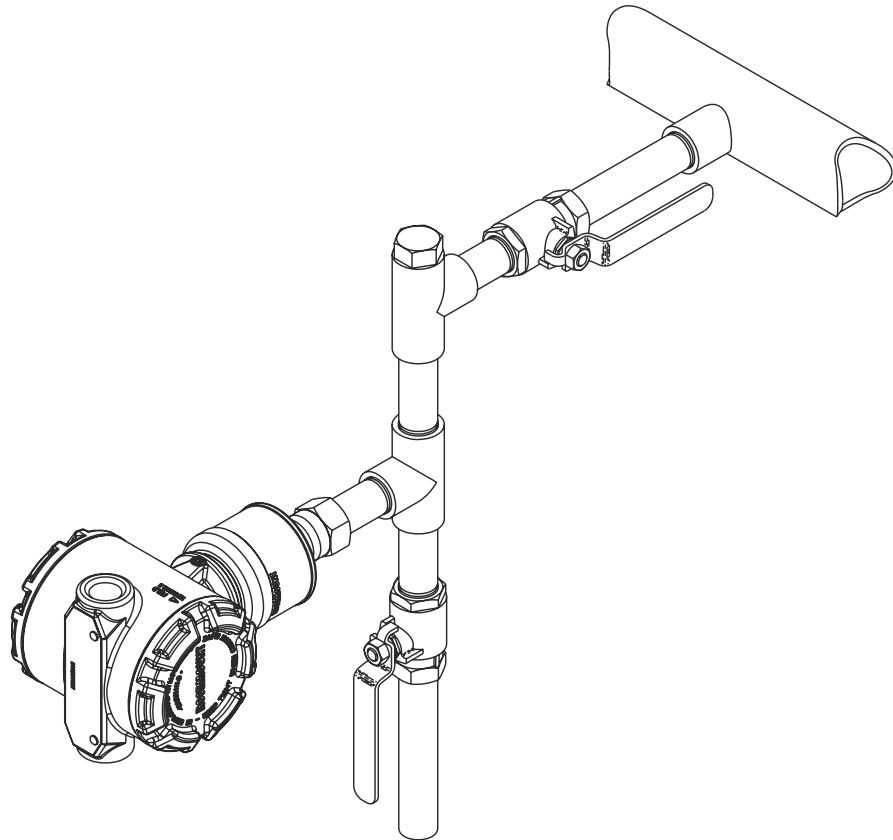

Figure 3-6: Inline Installation Example: Steam service



3.2.4

Draft range

Installation

For the Rosemount 3051S_CD0 Draft Range Pressure Transmitter, it is best to mount the transmitter with the isolators parallel to the ground. Installing the transmitter in this way reduces oil mounting effect and provides for optimal temperature performance.

Reducing process noise

There are two recommended methods of reducing process noise:

- Output damping
- Reference side filtering (in-gauge applications)

Reference side filtering

In gauge applications, it is important to minimize fluctuations in atmospheric pressure to which the low side isolator is exposed.

Methods of reducing fluctuations in atmospheric pressure:

- Attach a length of tubing to the reference side of the transmitter to act as a pressure buffer.
- Plumb the reference side to a chamber that has a small vent to atmosphere. If multiple draft transmitters are being used in an application, the reference side of each device can be plumbed to a chamber to achieve a common gauge reference.

3.3 Installation procedures

An overview of the installation steps for a Rosemount 3051S Pressure Transmitter is depicted in the [Figure 3-7](#). These steps are described in more detail in the following sections.

Figure 3-7: HART® Installation Flowchart

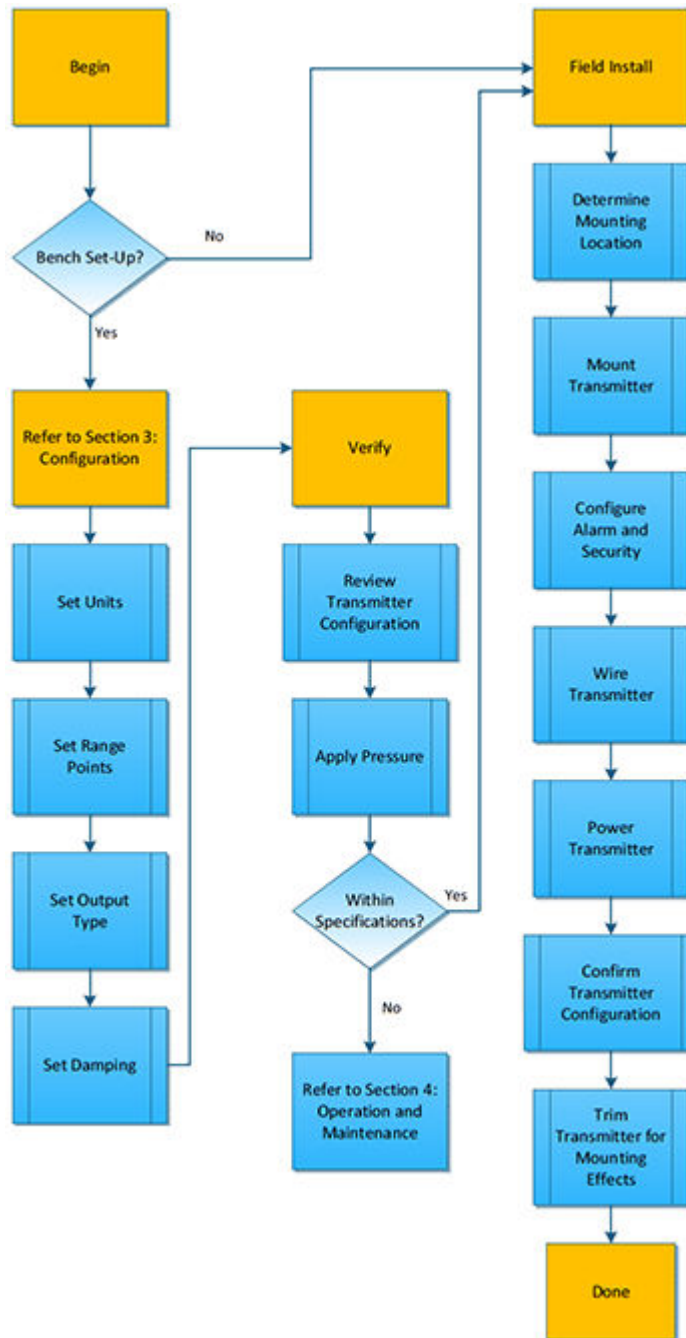

3.3.1 Mount the transmitter

LCD display

In addition to housing rotation, the optional display can be rotated in 90-degree increments by squeezing the two tabs, pulling out, rotating and snapping back into place.

If the LCD display pins are inadvertently removed from the interface board when the display is pulled from the housing, carefully remove the pins from the back of the display, and then re-insert the pins into the interface board. Once the pins are back in place, snap the display into place. Transmitters ordered with the LCD display will be shipped with the display installed.

Electronics housing clearance

Mount the transmitter so the terminal side and the LCD display are accessible. Clearance of 0.75 in. (19 mm) is required for cover removal on the terminal side. If a LCD display is installed, then 3 in. (76 mm) of clearance is required for cover removal .

Flange bolt installation

If the transmitter installation requires assembly of the process flanges, manifolds, or flange adapters, follow these assembly guidelines to ensure a tight seal for optimal performance characteristics of the transmitters. Use only bolts supplied with the transmitter or sold by Emerson as spare parts. [Figure 3-8](#) illustrates common transmitter assemblies with the bolt length required for proper transmitter assembly.

The transmitter can be shipped with a Coplanar™ flange or a traditional flange installed with four 1.75-in. (44.45 mm) flange bolts. Stainless steel bolts supplied by Emerson are coated with a lubricant to ease installation. Carbon steel bolts do not require lubrication. No additional lubricant should be applied when installing either type of bolt.

Bolts supplied by Emerson are identified by their head markings:

Figure 3-8: Flange bolt head markings

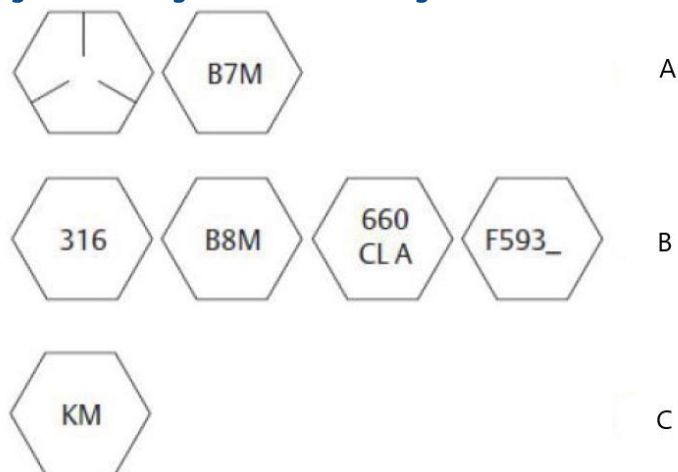

- A. Carbon steel (CS) head markings
- B. Stainless steel (SST) head markings
- C. Alloy K-500 head marking

Note

The last digit in the F593_ head marking may be any letter between A and M.

Bolt installation

Only use bolts supplied with the Rosemount 3051S or sold by Emerson as parts for the transmitter. The use of non approved bolts could reduce pressure. Use the following bolt installation procedure:

1. Finger-tighten the bolts.
2. Torque the bolts to the initial torque value using a crossing pattern.
3. Torque the bolts to the final torque value using the same crossing pattern.

Initial and final torque values for the flange and manifold adapter bolts are as follows:

Table 3-1: Torque Values

Bolt material	Initial torque value	Final torque value
Carbon steel-ASTM-A449 Standard	300 in.-lb. (34 N-m)	650 in.-lb. (73 N-m)
316 Stainless steel—Option L4	150 in.-lb. (17 N-m)	300 in.-lb. (34 N-m)
ASTM-A-193-B7M—Option L5	300 in.-lb. (34 N-m)	650 in.-lb. (73 N-m)
Alloy K-500 —Option L6	300 in.-lb. (34 N-m)	650 in.-lb. (73 N-m)
ASTM-A-453-660—Option L7	150 in.-lb. (17 N-m)	300 in.-lb. (34 N-m)
ASTM-A-193-B8M—Option L8	150 in.-lb. (17 N-m)	300 in.-lb. (34 N-m)

When installing the transmitter to one of the optional mounting brackets, torque the mounting bolts to 125 in-lb (14.1 N-m).

Figure 3-9: Flange Bolts and Adapters

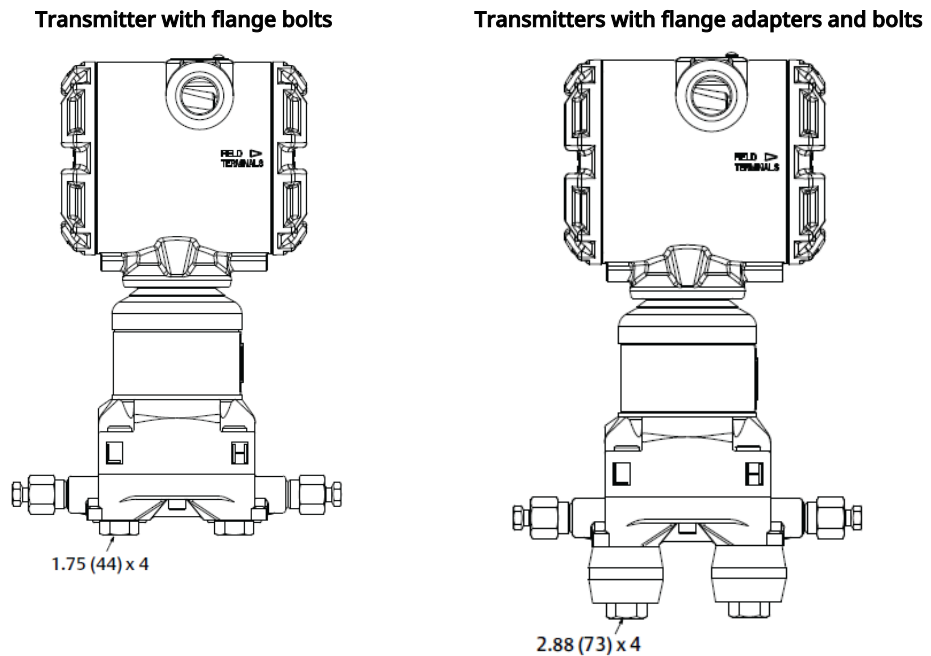

Note
Dimensions are in inches (millimeters).

Mounting brackets

Facilitate mounting transmitter to a 2-in. (50.8 mm) pipe, or to a panel. The B4 Bracket stainless steel option is standard for use with the coplanar and in-line process connections. See [Rosemount 3051S Series of Instrumentation Product Data Sheet](#) for bracket dimensions and mounting configurations for the B4 option.

Options B1–B3 and B7–B9 are sturdy, epoxy/polyester-painted brackets designed for use with the traditional flange. The B1–B3 brackets have carbon steel bolts, while the B7–B9 brackets have stainless steel bolts. The BA and BC brackets and bolts are stainless steel. The B1/B7/BA and B3/B9/BC style brackets support 2-in. (50.8 mm) pipe-mount installations, and the B2/B8 style brackets support panel mounting.

Table 3-2: Mounting brackets

<i>Panel mount</i>	<i>Coplanar flange</i>	<i>Pipe mount</i>
--------------------	------------------------	-------------------

Table 3-2: Mounting brackets (continued)

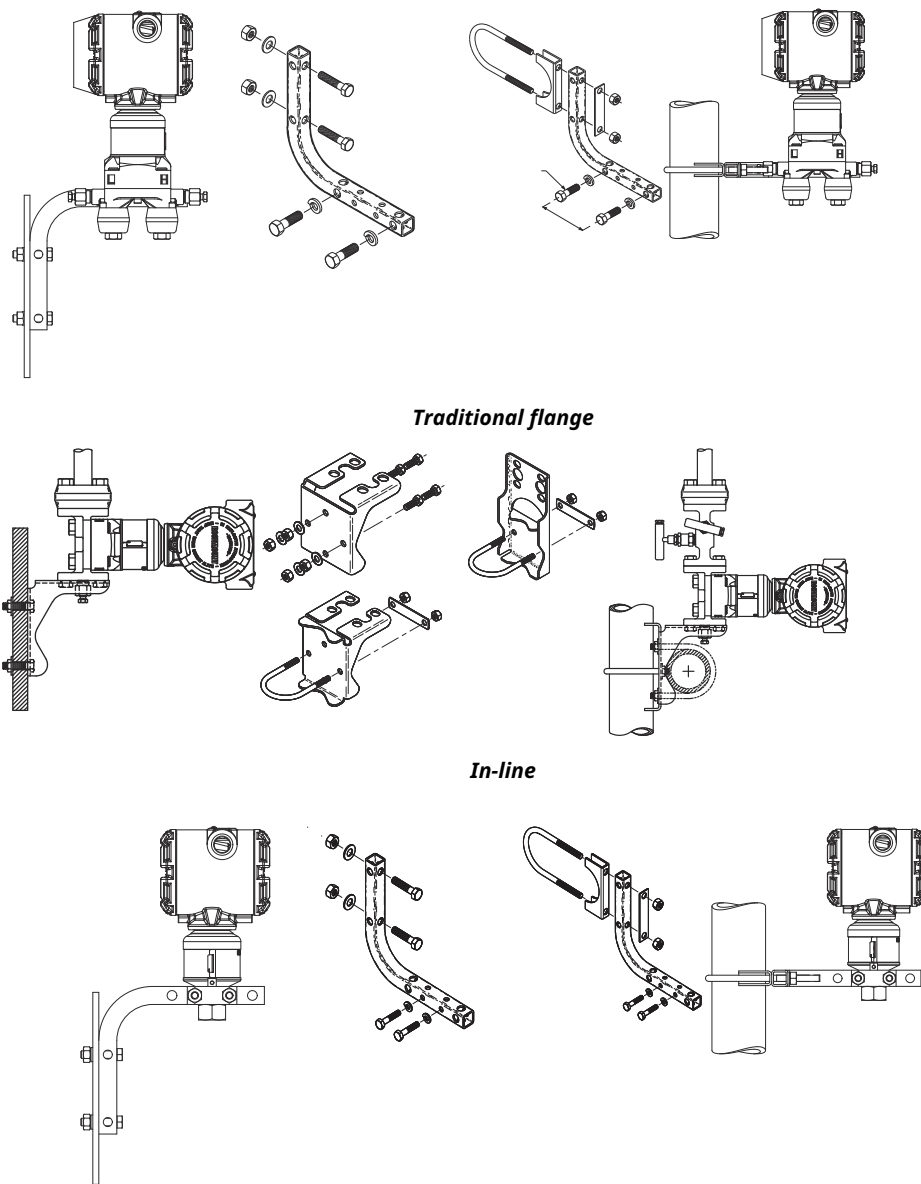

3.3.2 Impulse piping

Systems that will use impulse piping should follow the guidance in this section. Not all Rosemount 3051S measurement systems will use impulse piping, especially systems with remote seals, and Rosemount Annubar, compact orifice plates, or an integral orifice plate. Each of these systems has their own manual to assist with installation.

Mounting requirements

Impulse piping configurations depend on specific measurement conditions. Refer to [Figure 3-1](#) and [Figure 3-4](#) for examples of the following mounting configurations:

Steam service

NOTICE

For steam service or for applications with process temperatures greater than the limits of the transmitter, do not blow down impulse piping through the transmitter. Flush lines with the blocking valves closed and refill lines with water before resuming measurement.

Refer to [Figure 3-1](#) for correct mounting orientation.

Note

For steam or other elevated temperature services, it is important that temperatures at the process connection do not exceed the transmitter's process temperature limits.

Best practices

The piping between the process and the transmitter must accurately transfer the pressure to obtain accurate measurements. These are some possible sources of error: pressure transfer, leaks, friction loss (particularly if purging is used), trapped gas in a liquid line, liquid in a gas line, density variations between the legs, and plugged impulse piping.

The best location for the transmitter in relation to the process pipe is dependent on the process. Use the following guidelines to determine transmitter location and placement of impulse piping:

- Keep impulse piping as short as possible.
- For liquid service, slope the impulse piping at least 1 in./ft. (8 cm/m) upward from the transmitter toward the process connection.
- For gas service, slope the impulse piping at least 1 in./ft. (8 cm/m) downward from the transmitter toward the process connection.
- Avoid high points in liquid lines and low points in gas lines.
- Ensure both impulse legs are the same temperature.
- Use impulse piping large enough to avoid friction effects and blockage.
- Vent all gas from liquid piping legs.
- When using a sealing fluid, fill both piping legs to the same level.
- When purging, make the purge connection close to the process taps and purge through equal lengths of the same size pipe. Avoid purging through the transmitter.
- Keep corrosive or hot (above 250 °F [121 °C]) process material out of direct contact with the sensor module and flanges.
- Prevent sediment deposits in the impulse piping.
- Maintain equal leg of head pressure on both legs of the impulse piping.
- Avoid conditions that might allow process fluid to freeze within the process flange.

3.3.3 Liquid measurement

1. Place taps to the side of the line to prevent sediment deposits on the transmitter's process isolators.
2. Mount the transmitter beside or below the taps so gases can vent into the process line.
3. Mount drain/vent valve upward to allow gases to vent.

3.3.4 Gas measurement

1. Place taps in the top or side of the line.
2. Mount the transmitter beside or above the taps so liquid will drain into the process line.

3.3.5 Steam measurement

1. Place taps to the side of the line.
2. Mount the transmitter below the taps to ensure that the impulse piping will stay filled with condensate.
3. In steam service above 250 °F (121 °C), fill impulse lines with water to prevent steam from contacting the transmitter directly and to ensure accurate measurement start-up.

3.3.6 Process connections

Flange bolt installation

If the transmitter installation requires assembly of the process flanges, manifolds, or flange adapters, follow these assembly guidelines to ensure a tight seal for optimal performance characteristics of the transmitters. Use only bolts supplied with the transmitter or sold by Emerson as spare parts. [Figure 3-10](#) illustrates common transmitter assemblies with the bolt length required for proper transmitter assembly.

The transmitter can be shipped with a Coplanar™ flange or a traditional flange installed with four 1.75-in. (44.45 mm) flange bolts. Stainless steel bolts supplied by Emerson are coated with a lubricant to ease installation. Carbon steel bolts do not require lubrication. No additional lubricant should be applied when installing either type of bolt.

Bolts supplied by Emerson are identified by their head markings:

Figure 3-10: Flange bolt head markings

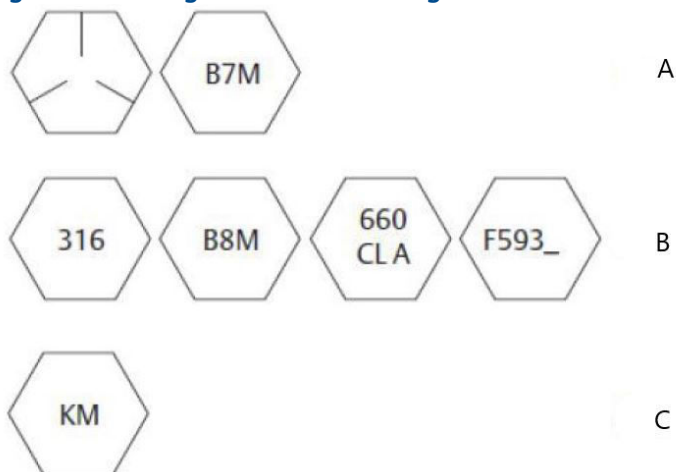

- A. Carbon steel (CS) head markings
- B. Stainless steel (SST) head markings
- C. Alloy K-500 head marking

Note

The last digit in the F593_ head marking may be any letter between A and M.

In-line process connection

In-line gauge transmitter orientation

NOTICE

Equipment damage

Interfering or blocking the atmospheric reference port will cause the transmitter to output erroneous pressure values.

The low side pressure port (atmospheric reference) on the in-line gauge transmitter is located under the sensor module neck label. See [Figure 3-11](#).

NOTICE

Keep the vent path free of any obstruction, such as paint, dust, and lubrication by mounting the transmitter so that any contaminants can drain away.

Figure 3-11: In-line Gauge Low Side Pressure Port

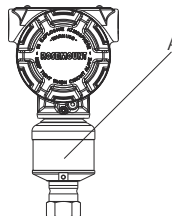

- A. Low side pressure port (under neck label)

3.3.7 Housing rotation

To improve field access to wiring or to better view the optional LCD display:

1. Loosen the housing rotation set screw.
2. First rotate the housing clockwise to the desired location. If the desired location cannot be achieved due to thread limit, rotate the housing counterclockwise to the desired location (up to 360° from thread limit).
3. Re-tighten the housing rotation set screw.

Figure 3-12: Plantweb™ Housing

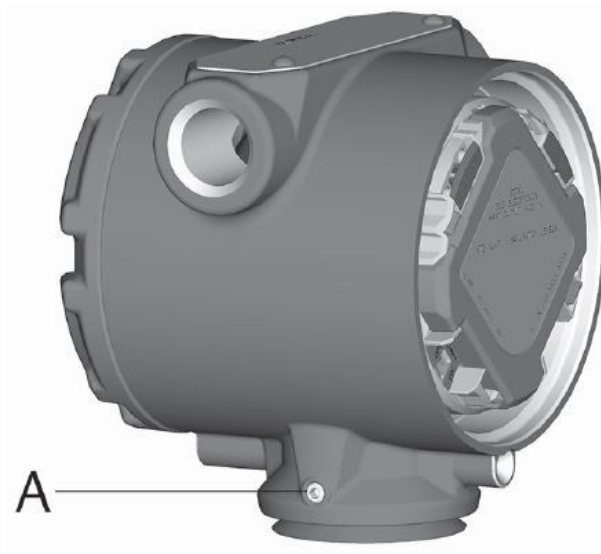

A. Set screw

Figure 3-13: Junction box housing

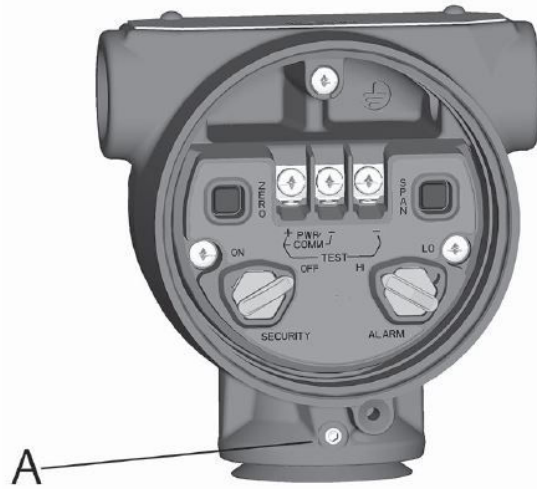

A. Set screw

3.4 Flange bolt installation

If the transmitter installation requires assembly of the process flanges, manifolds, or flange adapters, follow these assembly guidelines to ensure a tight seal for optimal performance characteristics of the transmitters. Use only bolts supplied with the transmitter or sold by Emerson as spare parts. Figure 3-14 illustrates common transmitter assemblies with the bolt length required for proper transmitter assembly.

The transmitter can be shipped with a Coplanar™ flange or a traditional flange installed with four 1.75-in. (44.45 mm) flange bolts. Stainless steel bolts supplied by Emerson are coated with a lubricant to ease installation. Carbon steel bolts do not require lubrication. No additional lubricant should be applied when installing either type of bolt.

Bolts supplied by Emerson are identified by their head markings:

Figure 3-14: Flange bolt head markings

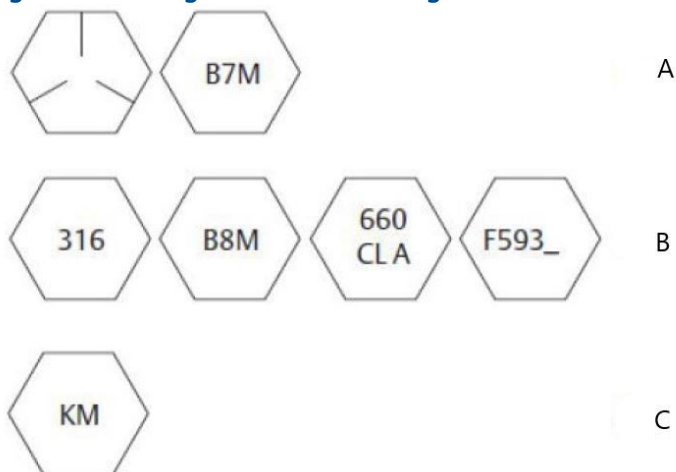

- A. Carbon steel (CS) head markings
- B. Stainless steel (SST) head markings
- C. Alloy K-500 head marking

Note

The last digit in the F593_ head marking may be any letter between A and M.

3.4.1 Rosemount 304 and 305 Manifold styles

Rosemount 304 Manifolds

The 304 comes in two basic styles: traditional (flange + flange and flange + pipe) and wafer. The 304 Traditional Manifold comes in 2-, 3-, and 5-valve configurations. The 304 Wafer Manifold comes in 3- and 5-valve configurations.

Figure 3-15: 304 Manifold Styles

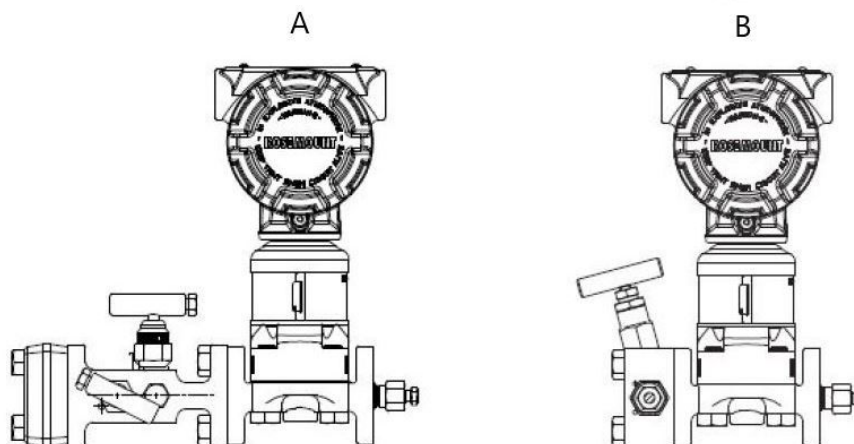

- A. Traditional
- B. Wafer

Rosemount 305 Integral Manifold

The 305 Integral Manifold is available in two styles: coplanar and traditional. The traditional 305 can be mounted to most primary elements with mounting adapters.

Figure 3-16: 305 Integral Manifold Styles

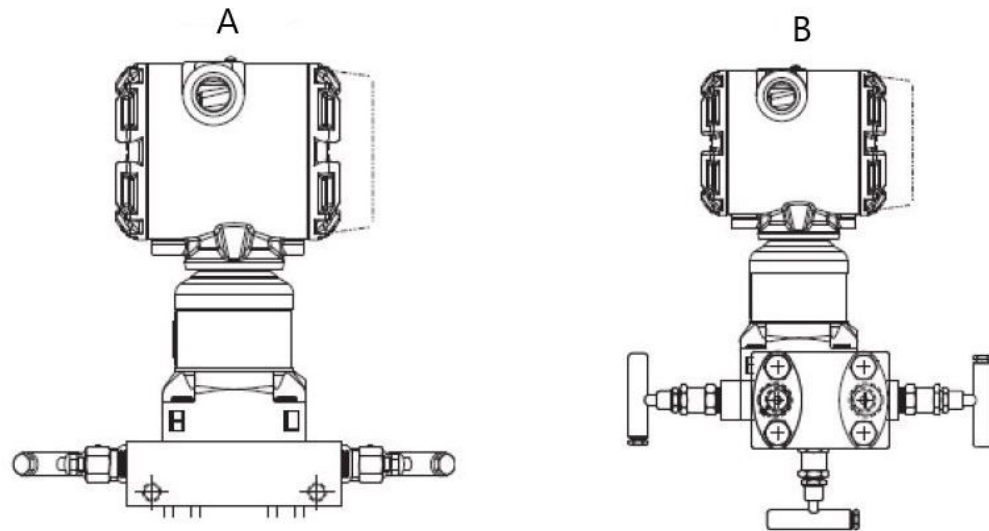

A. Coplanar
B. Traditional

3.4.2 Rosemount 304 Conventional Manifold installation

To install a 304 Conventional Manifold to a 3051 Transmitter:

Procedure

1. Align the Conventional Manifold with the transmitter flange. Use the four manifold bolts for alignment.
2. Finger-tighten the bolts, then tighten the bolts incrementally in a cross pattern to final torque value.
See [Flange bolt installation](#) for complete bolt installation information and torque values.
When fully tightened, the bolts will extend through the top of the sensor module housing.
3. Leak-check assembly to maximum pressure range of transmitter.

3.4.3 Rosemount 305 Integral Manifold installation procedure

Prerequisites

Inspect the PTFE sensor module O-rings:

- If the O-rings are undamaged, then Emerson recommends reusing them.
- If the O-rings are damaged (if they have nicks or cuts, for example), replace them with new O-rings designed for Rosemount transmitters.

NOTICE

If replacing the O-rings, be careful not to scratch or deface the O-ring grooves or the surface of the isolating diaphragm when removing the damaged O-rings.

Procedure

1. Install the integral manifold on the sensor module:
 - a) Finger-tighten the bolts.
 - b) Tighten the bolts incrementally in a cross pattern to final torque value.

Figure 3-17: Tighten the bolts

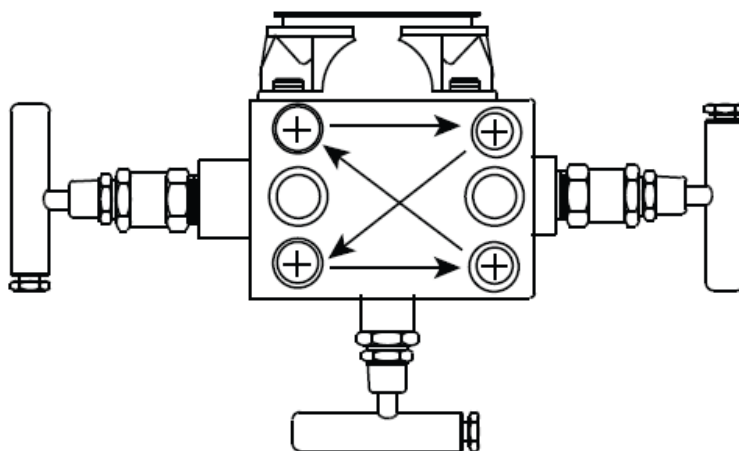

See [#unique_99/unique_99_Connect_42_table_fcw_q4f_w3b](#) for complete bolt installation information and for torque values.

When fully tightened, the bolts should extend through the top of the module housing plane of the flange web (bolt hole) but must not contact the module housing.

2. If the PTFE sensor module O-rings have been replaced, re-tighten the flange bolts after installation to compensate for cold flow of the O-rings.

3.4.4 Rosemount 306 Integral Manifold installation procedure

The 306 is for use only with a 3051S In-line Transmitter.

Assemble the 306 to the 3051S with a thread sealant. The proper installation torque value for a 306 Manifold is 425 in-lb.

3.4.5 Manifold operation

⚠ WARNING

Process Leaks

Improper installation or operation of manifolds may result in process leaks, which may cause death or serious injury.

Always perform a zero trim on the transmitter/manifold assembly after installation to eliminate any shift due to mounting effects.

Coplanar transmitters

3- and 5-valve manifolds

In normal operation the two isolate (block) valves between the process ports and transmitter will be open and the equalize valve will be closed.

Figure 3-18: Normal operation

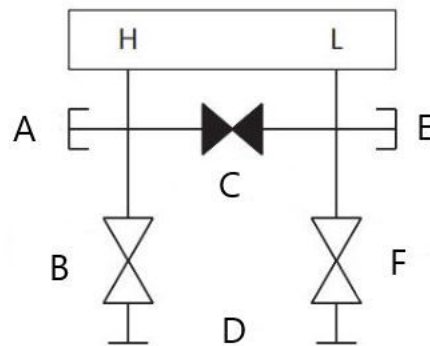

- A. Drain/Vent valve
- B. Isolate (open)
- C. Equalize (closed)
- D. Process
- E. Drain/Vent valve
- F. Isolate (open)

Procedure

1. To zero trim the transmitter, close the isolate valve on the low side (downstream) side of the transmitter.

Figure 3-19: Zero-trim

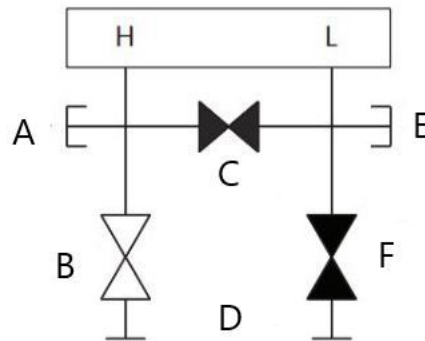

- A. Drain/Vent valve
- B. Isolate (open)
- C. Equalize (closed)
- D. Process
- E. Drain/Vent valve
- F. Isolate (closed)

2. Open the equalize valve to equalize the pressure on both sides of the transmitter. The manifold is now in the proper configuration for performing a zero trim on the transmitter.

Figure 3-20: Open the equalize valve

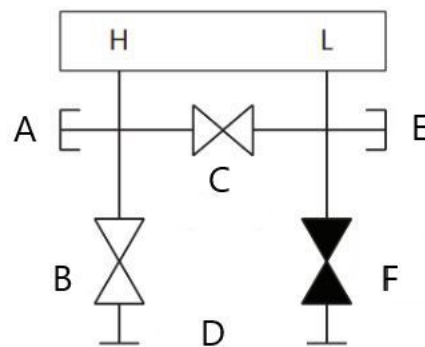

- A. Drain/Vent valve
- B. Isolate (open)
- C. Equalize (open)
- D. Process
- E. Drain/Vent valve
- F. Isolate (closed)

3. After performing a zero trim on the transmitter, close the equalize valve.

Figure 3-21: Close the equalize valve

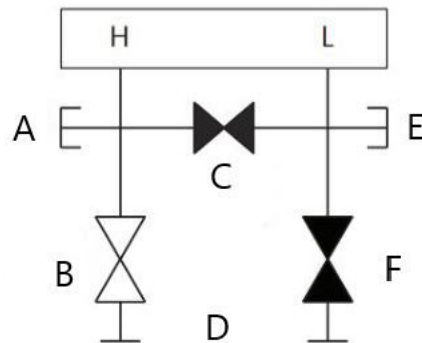

- A. Drain/Vent valve
- B. Isolate (open)
- C. Equalize (closed)
- D. Process
- E. Drain/Vent valve
- F. Isolate (closed)

4. Finally, to return the transmitter to service, open the low side isolate valve.

Figure 3-22: Return transmitter to service

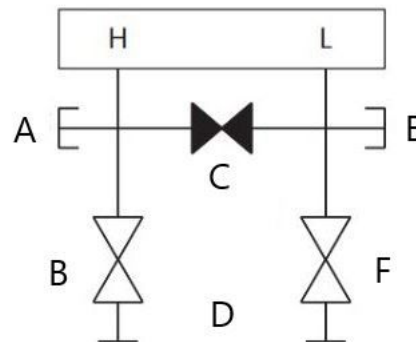

- A. Drain/Vent valve
- B. Isolate (open)
- C. Equalize (closed)
- D. Process
- E. Drain/Vent valve
- F. Isolate (closed)

Performing zero trim at static line pressure with 3-valve and 5-valve manifolds

In normal operation, the two isolate (block) valves between the process ports and transmitter will be open and the equalize valve will be closed.

Figure 3-23: Normal operation

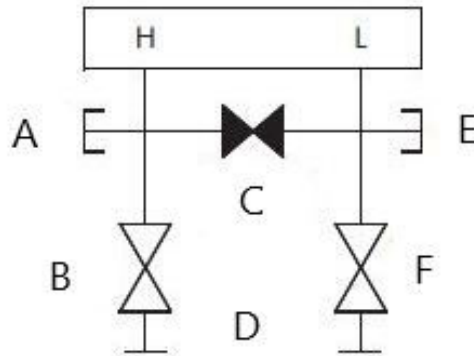

- A. Drain/vent valve
- B. Isolate (open)
- C. Equalize (closed)
- D. Process
- E. Drain/vent valve
- F. Isolate (open)

Procedure

1. To zero trim the transmitter, close the isolate valve on the low side (downstream) side of the transmitter.

Figure 3-24: Zero-trim

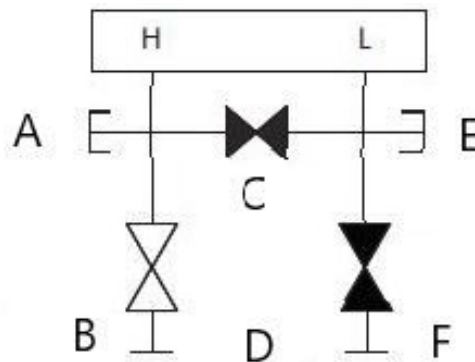

- A. Drain/vent valve
- B. Isolate (open)
- C. Equalize (closed)
- D. Process
- E. Drain/vent valve
- F. Isolate (closed)

2. Open the equalize valve to equalize the pressure on both sides of the transmitter. The manifold is now in the proper configuration for performing a zero trim on the transmitter.

Figure 3-25: Open the equalize valve

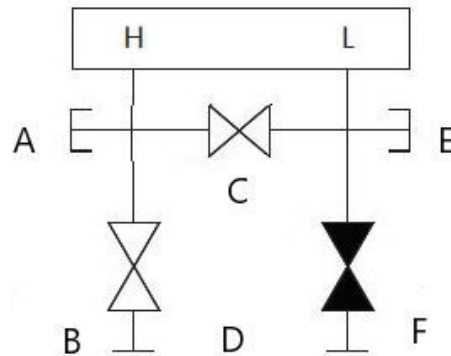

- A. Drain/vent valve
- B. Isolate (open)
- C. Equalize (open)
- D. Process
- E. Drain/vent valve
- F. Isolate (closed)

3. After performing a zero trim on the transmitter, close the equalize valve.

Figure 3-26: Close the equalize valve

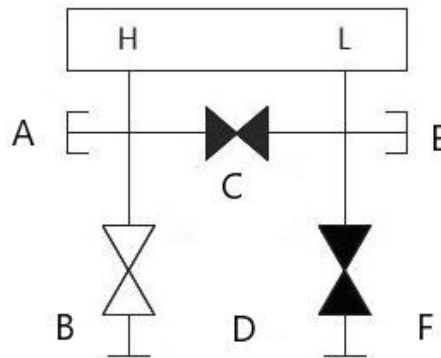

- A. Drain/vent valve
- B. Isolate (open)
- C. Equalize (open)
- D. Process
- E. Drain/vent valve
- F. Isolate (closed)

4. Finally, to return the transmitter to service, open the low side isolate valve.

Figure 3-27: Low side isolate valve

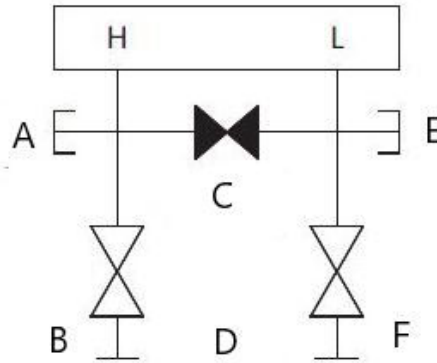

- a. Drain/vent valve
- b. Isolate (open)
- c. Equalize (closed)
- d. Process
- e. Drain/vent valve
- f. Isolate (open)

Performing zero trim at static line pressure with 5-valve natural gas manifold

5-valve natural gas configurations shown:

In normal operation, the two isolate (block) valves between the process ports and transmitter will be open, and the equalize valves will be closed. Vent valves may be opened or closed.

Figure 3-28: Normal operation

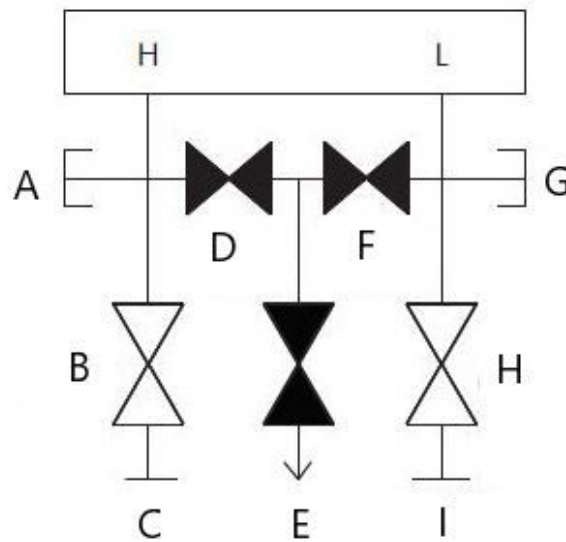

- A. Plugged
- B. Isolate (open)
- C. Process
- D. Equalize (closed)
- E. Drain vent (closed)
- F. Equalize (closed)
- G. Plugged
- H. Isolate (open)
- I. Process

Procedure

1. To zero trim the transmitter, first close the isolate valve on the low-pressure (downstream) side of the transmitter and the vent valve.

Figure 3-29: Zero-trim

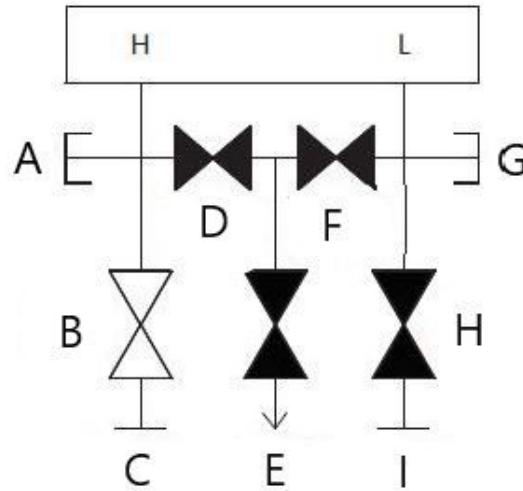

- A. Plugged
- B. Isolate (open)
- C. Process
- D. Equalize (closed)
- E. Drain vent (closed)
- F. Equalize (closed)
- G. Plugged
- H. Isolate (closed)
- I. Process

2. Open the equalize valve on the high-pressure (upstream) side of the transmitter.

Figure 3-30: Open the high-pressure equalize valve

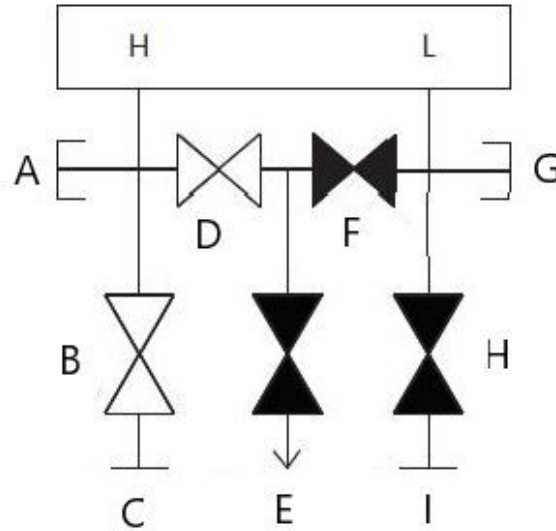

- A. Plugged
- B. Isolate (open)
- C. Process
- D. Equalize (open)
- E. Drain vent (closed)
- F. Equalize (closed)
- G. Plugged
- H. Isolate (closed)
- I. Process

3. Open the equalize valve on the low-pressure (downstream) side of the transmitter. The manifold is now in the proper configuration for performing a zero trim on the transmitter.

Figure 3-31: Open the low-pressure equalize valve

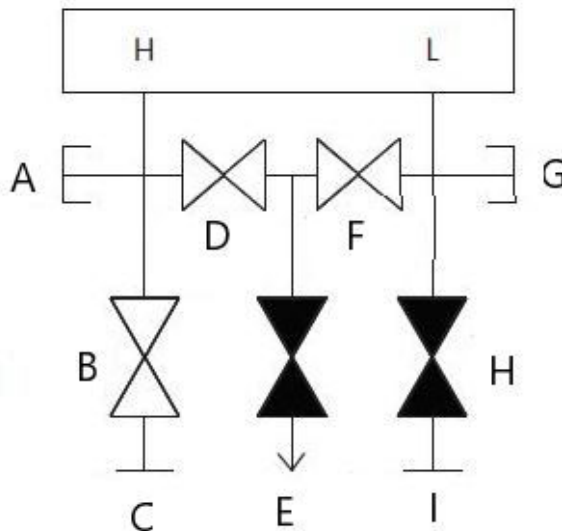

- A. Plugged
- B. Isolate (open)
- C. Process
- D. Equalize (open)
- E. Drain vent (closed)
- F. Equalize (open)
- G. Plugged
- H. Isolate (closed)
- I. Process

4. After performing a zero trim on the transmitter, close the equalize valve on the low-pressure (downstream) side of the transmitter.

Figure 3-32: Close the low-pressure equalize valve

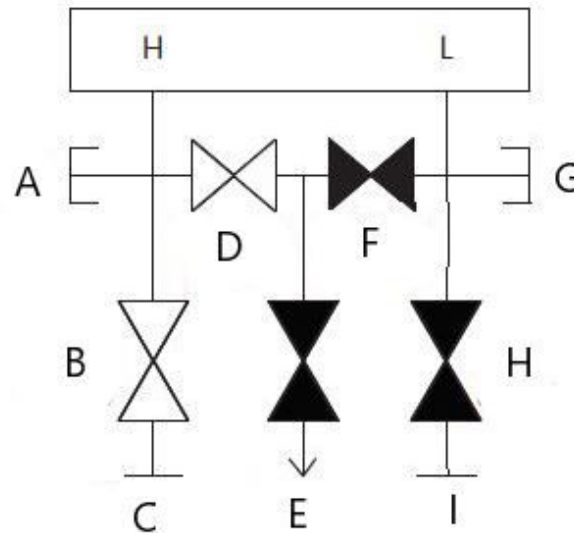

- A. Plugged
- B. Isolate (open)
- C. Process
- D. Equalize (open)
- E. Drain vent (closed)
- F. Equalize (closed)
- G. Plugged
- H. Isolate (closed)
- I. Process

5. Close the equalize valve on the high-pressure (upstream) side.

Figure 3-33: Close the high-pressure equalize valve

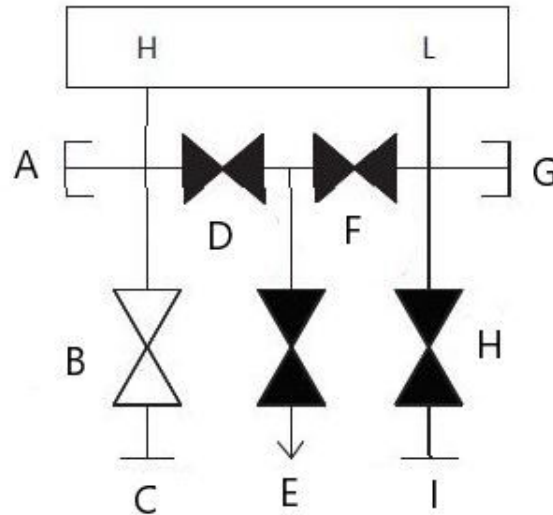

- A. Plugged
- B. Isolate (open)
- C. Process
- D. Equalize (closed)
- E. Drain vent (closed)
- F. Equalize (closed)
- G. Plugged
- H. Isolate (closed)
- I. Process

6. Finally, to return the transmitter to service, open the low side isolate valve and vent valve.

The vent valve can remain open or closed during operation.

Figure 3-34: Return transmitter to service

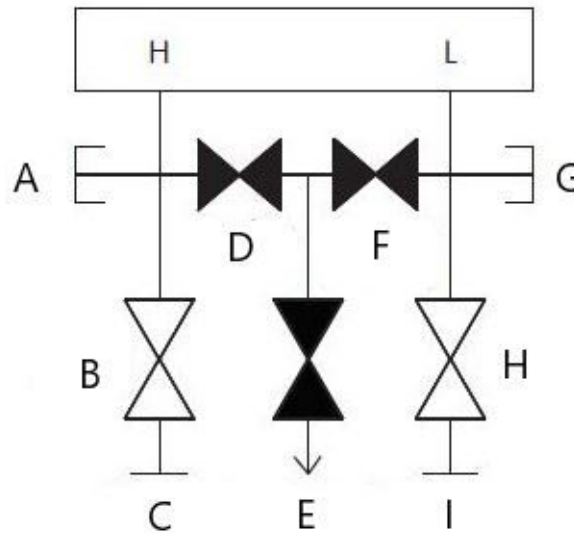

- A. Plugged
- B. Isolate (open)
- C. Process
- D. Equalize (closed)
- E. Drain vent (closed)
- F. Equalize (closed)
- G. Plugged
- H. Isolate (open)
- I. Process

In-line transmitter

Isolating the transmitter with 2-valve and block and bleed style manifolds

In normal operation the isolate (block) valve between the process port and transmitter will be open and the test/vent valve will be closed. On a block and bleed style manifold, a single block valve provides transmitter isolation and a bleed screw provides drain/vent capabilities.

Figure 3-35: Normal operation

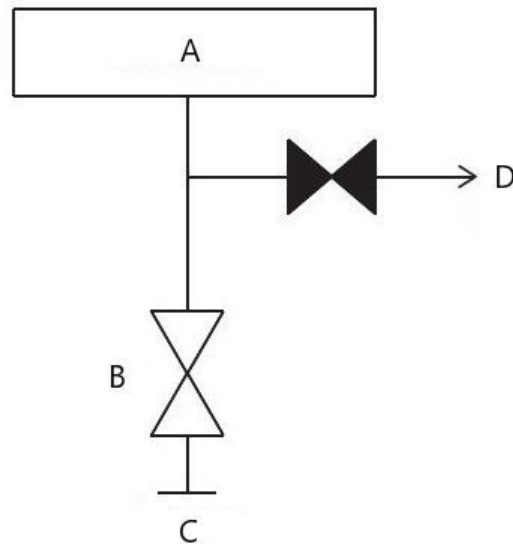

- A. Transmitter
- B. Isolate
- C. Process (open)
- D. Vent (closed)

Procedure

1. To isolate the transmitter, close the isolate valve.

Figure 3-36: Close the isolate valve

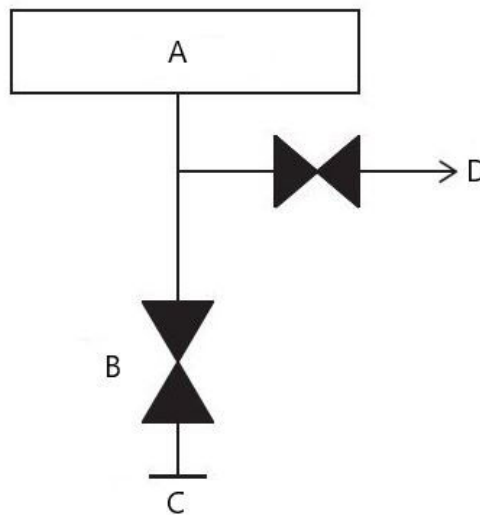

- A. Transmitter
- B. Isolate
- C. Process (closed)
- D. Vent (closed)

2. To bring the transmitter to atmospheric pressure, open the vent valve or bleed screw.

NOTICE

Always use caution when venting directly to atmosphere. A ¼ in male NPT pipe plug may be installed in the test/vent port and will need to be removed with a wrench in order to vent the manifold properly.

Figure 3-37: Open the vent or bleed screw

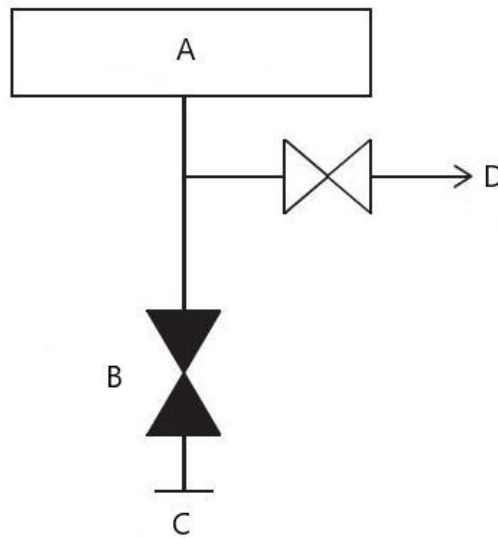

- A. Transmitter
- B. Isolate
- C. Process (closed)
- D. Vent (open)

3. After venting to atmosphere, perform any required calibration and then close the test/vent valve or replace the bleed screw.

Figure 3-38: Close test/vent valve or replace bleed screw

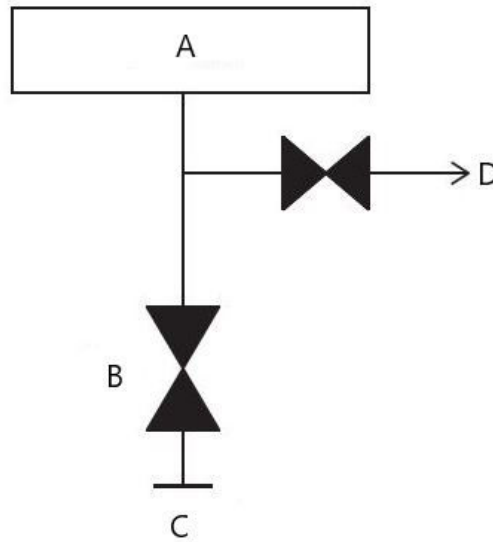

- A. Transmitter
- B. Isolate
- C. Process (closed)
- D. Vent (closed)

4. Open the Isolate (block) valve to return the transmitter to service.

Figure 3-39: Open Isolate (block) valve

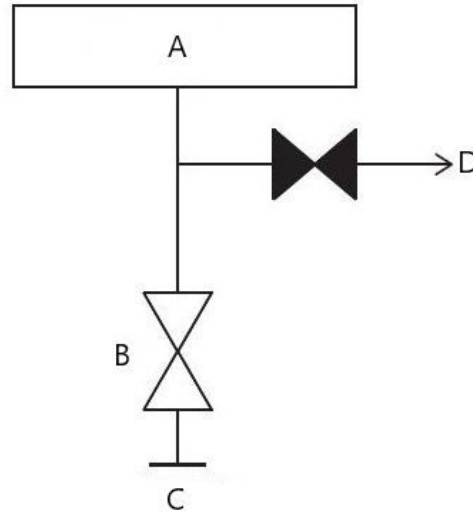

- A. Transmitter
- B. Isolate
- C. Process (open)
- D. Vent (closed)

3.5 Wiring the device

Remove orange conduit plugs

Use a conduit plug in the unused conduit opening. Thread-sealing PTFE tape or paste on male threads of conduit is required to provide a water/dust tight conduit seal and meets requirements of NEMA® Type 4X, IP66, and IP68. Consult [Emerson.com/global](https://www.emerson.com/global) if other Ingress Protection ratings are required.

For M20 threads, install conduit plugs to full thread engagement or until mechanical resistance is met.

NOTICE

Remove orange plugs from the transmitter conduit openings. The orange plugs are used to keep the housing free of debris during shipping. They are not meant to be in the conduit openings when the transmitter is installed and in use.

Install pipe plug in unused conduit opening

Important

Install the enclosed pipe plug (found in the box) in the unused conduit opening.

- For straight threads, a minimum of six threads must be engaged.
- For tapered threads, install the plug wrench-tight.

For material compatibility considerations, refer to [Material Selection and Compatibility Considerations for Rosemount Pressure Transmitters Technical Note](#).

3.5.1 Wire the device

Use twisted pairs to yield best results. To ensure proper communication, use 24 to 14 AWG wire. Do not exceed 5,000 ft. (1,500 m).

NOTICE

Determine local wiring and conduit requirements. Understand local wiring and conduit requirements prior to installation and be sure to follow all regulations during the transmitter's installation.

Figure 3-40: HART Terminal Blocks

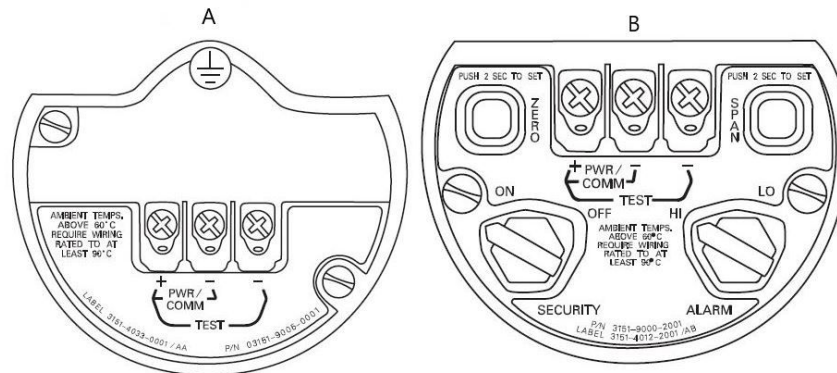

- A. Plantweb
- B. Junction box

Procedure

1. Remove the housing cover on terminal compartment side. Signal wiring supplies all power to the transmitter.

⚠ WARNING

Do not remove the cover in explosive environments when the circuit is live.

2. Connect the positive lead to the terminal marked (+) and the negative lead to the terminal marked (PWR/COMM-).

NOTICE

Avoid contact with leads and terminals. Do not connect powered signal wiring to the test terminals. Power could damage the test diode.

3. Ensure full contact with terminal block screw and washer. When using a direct wiring method, wrap wire clockwise to ensure it is in place when tightening the terminal block screw.

NOTICE

Emerson does not recommend using a pin or ferrule as the connection may be more susceptible to loosening over time or under vibration.

4. Plug and seal the unused conduit connection on the transmitter housing to avoid moisture accumulation in the terminal side. Install wiring with a drip loop. Arrange the drip loop so the bottom is lower than the conduit connections and the transmitter housing.

Surges or transients

NOTICE

The transmitter will withstand electrical transients of the energy level usually encountered in static discharges or induced switching transients. However, high-energy transients, such as those induced in wiring from nearby lightning strikes, can damage the transmitter.

Optional transient protection terminal block

The transient protection terminal block can be ordered as an installed option (Option Code T1 in the transmitter model number) or as a spare part to retrofit existing 3051S Transmitters in the field. For a complete listing of spare part numbers for transient protection terminal blocks, refer to [Table 4-2](#). A lightning bolt symbol on a terminal block identifies it as having transient protection.

Signal wiring grounding

⚠ WARNING

Do not run signal wiring in conduit or open trays with power wiring, or near heavy electrical equipment. Grounding terminations are provided on the sensor module and inside the terminal compartment. These grounds are used when transient protect terminal blocks are installed or to fulfill local regulations.

The following section details more information on how the cable shield should be grounded.

Electrical considerations

⚠ WARNING

Proper electrical installation is necessary to prevent errors due to improper grounding and electrical noise. For Junction Box housing, shielded signal wiring should be used in high EMI/RFI environments.

Note

Verify transmitter zero point after installation. To reset zero point, refer to [Sensor trim overview](#).

Cover installation

NOTICE

Always ensure a proper seal by installing the electronics housing cover(s) so that metal contacts metal. Use Rosemount O-rings.

3.5.2 Ground the transmitter housing

Transmitter case

⚠ WARNING

Always ground the transmitter case in accordance with national and local electrical codes. The most effective transmitter case grounding method is a direct connection to earth ground with minimal impedance. Methods for grounding the transmitter case include an internal ground connection.

The internal ground connection screw is inside the terminal side of the electronics housing. The screw is identified by a ground symbol () and is standard on all Rosemount 3051S Transmitters.

Table 3-3: Option Codes with External Ground Screw Included

Option code	Description
E1	ATEX Flameproof
N1	ATEX Type n
ND	ATEX Dust
E4	TIIS Flameproof
K1	ATEX Flameproof, Intrinsic Safety, Type n, Dust (combination of E1, I1, N1, and ND)
E7	IECEX Flameproof, Dust ignition-proof
N7	IECEX Type n
K7	IECEX Flameproof, Dust ignition-proof, Intrinsic Safety, and Type n (combination of E7, I7, and N7)
KA	ATEX and CSA Explosion-proof, Intrinsically Safe, Division 2 (combination of E1, E6, I1, and I6)
KC	FM and ATEX Explosion-proof, Intrinsically Safe, Division 2 (combination of E5, E1, I5, and I1)
T1	Transient terminal block
D4	External ground screw assembly

NOTICE

Grounding the transmitter case using the threaded conduit connection may not provide a sufficient ground. The transient protection terminal block (option code T1) will not provide transient protection unless the transmitter case is properly grounded. Use the above guidelines to ground the transmitter case. Do not run transient protection ground wire with signal wiring; the ground wire may carry excessive current if a lightning strike occurs.

3.5.3 Remote display wiring and power up

The remote mount display and interface system consists of a local transmitter and a remote mount LCD display assembly. The local Rosemount 3051S Transmitter assembly includes a junction box housing with a three position terminal block integrally mounted to a SuperModule. The remote mount LCD display assembly consists of a dual compartment Plantweb housing with a seven position terminal block. See [Figure 1](#) for complete wiring instructions. The following is a list of necessary information specific to the remote mount display system:

- Each terminal block is unique for the remote display system.
- A 316 SST housing adapter is permanently secured to the remote mount LCD display Plantweb housing providing an external ground and a means for field mounting with the provided mounting bracket.
- A cable is required for wiring between the transmitter and remote mount LCD display. The cable length is limited to 100 ft. (30 m)
- 50 ft. (50 m) (option M8) or 100 ft. (30 m) (option M9) cable is provided for wiring between the transmitter and remote mount LCD display. Option M7 does not include cable. Other comparable cable may be used as long as it has independent dual twisted shielded pair wires with an outer shield. The power wires must be 22 AWG minimum and the CAN communication wires must be 24 AWG minimum.

Note

Cable length may be up to 100 ft. (31 m), depending on cable capacitance. The capacitance as wired must be less than 5,000 picofarads total. This allows up to 50 picofarads per 1 ft. (0.3 m) for a 100 ft. (31 m) cable.

⚠ WARNING

Intrinsic Safety Consideration:The transmitter assembly with remote display has been approved with Madison AWM Style 2549 cable. Alternate cable may be used as long as the transmitter with remote display and cable is configured according to the installation control drawing or certificate. Refer to appropriate approval certificate or control drawing in for remote cable IS requirements.

NOTICE

Do not apply power to the remote communications terminal. Follow wiring instructions carefully to prevent damage to system components.

NOTICE

For ambient temperatures above 140 °F (60 °C), cable wiring must be rated at least 9 °F (5 °C) above the maximum ambient temperature.

Figure 3-41: Remote Mount Display Wiring Diagram

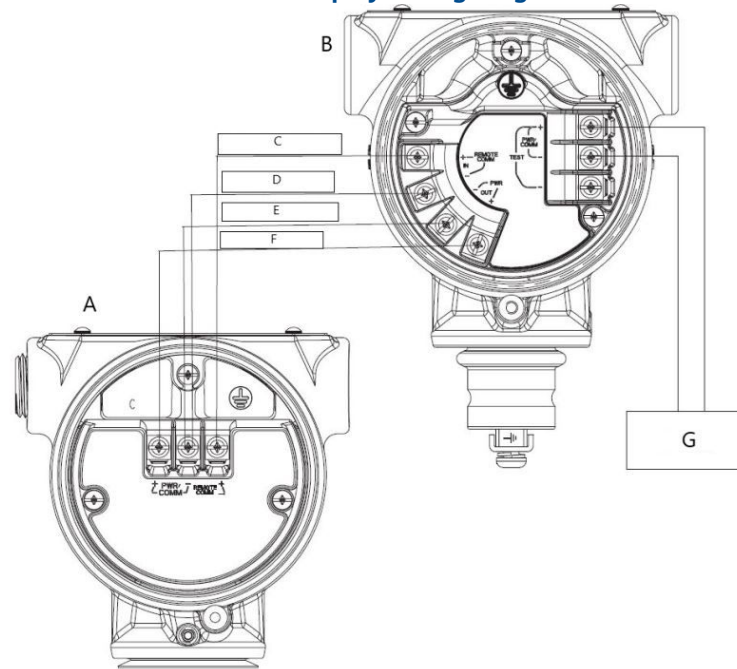

- A. Junction box housing
- B. Remote mount display
- C. White 24 AWG
- D. Blue 24 AWG
- E. Black 22 AWG
- F. Red 22 AWG
- G. 4-20 mA

Note

Wire colors provided above are per Madison AWM Style 2549 cable. Wire color may vary depending on cable selected.

Madison AWM Style 2549 cable includes a ground shield. This shield must be connected to earth ground at either the SuperModule™ or the remote display, but not both.

3.5.4 Eurofast®/Minifast® connection

For Rosemount 3051S Transmitters with conduit electrical connectors GE or GM, refer to the cordset manufacturer's installation instructions for wiring details. For FM Intrinsically Safe, non-incendive or FM FISCO Intrinsically Safe hazardous locations, install in accordance with Rosemount drawing 03151-1009 to maintain outdoor rating (NEMA® and IP66).

Reassembly of conduit receptacles

If the conduit receptacle is removed or replaced, follow the instructions below to re-wire the GE or GM conduit receptacle to the terminal block:

Procedure

1. Connect the green/yellow lead wire to the internal ground screw.

2. Connect the brown lead wire to the terminal marked (+).
3. Connect the blue lead wire to the terminal marked (pwr/comm-).

3.5.5 Quick Connect wiring

As standard, the Rosemount 3051S Quick Connect arrives properly assembled to the SuperModule and is ready for installation. Cordsets and field wireable connectors (in shaded area) are sold separately.

Figure 3-42: Quick Connect Exploded View

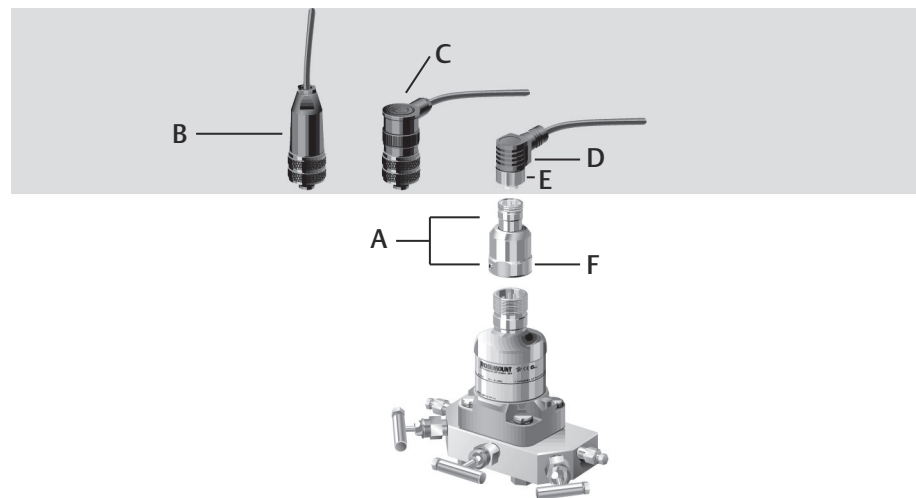

- A. Quick Connect housing
- B. Straight field wireable connector ⁽¹⁾ ⁽²⁾
- C. Right angle field wireable connector ⁽³⁾⁽²⁾
- D. Cordset ⁽⁴⁾
- E. Cordset/field wireable coupling nut
- F. Quick Connect coupling nut

Important

If Quick Connect is ordered as a 300S spare housing or is removed from the SuperModule, follow the instructions for proper assembly prior to field wiring.

Procedure

1. Place the Quick Connect onto the SuperModule. To ensure proper pin alignment, remove coupling nut prior to installing quick Connect onto SuperModule.
2. Place coupling nut over quick connect and wrench tighten to a maximum of 300 in-lb (34 N-m).
3. Tighten the set screw using a 3/32-in. hex wrench.
4. Install cordset/Field Wireable Connectors onto the Quick Connect. Do not overtighten.

⁽¹⁾ Order part number 03151-9063-0001.

⁽²⁾ Field wiring supplied by customer.

⁽³⁾ Order part number 03151-9063-0002.

⁽⁴⁾ Supplied by cordset vendor.

Figure 3-43: Quick Connect Housing Pin-Out

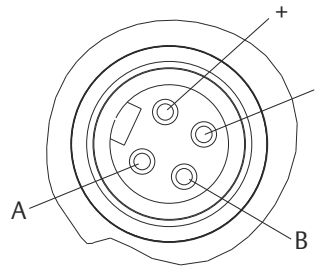

- A. Ground
- B. No connection

For other wiring details, refer to pin-out drawing and the cordset manufacturer's installation instructions.

3.5.6 Power the transmitter

Power supply 4–20 mA transmitters

The DC power supply should provide power with less than two percent ripple. Total resistance load is the sum of resistance from signal leads and the load resistance of the controller, indicator, and related pieces. Note the resistance of intrinsic safety barriers, if used, must be included.

3.5.7 Cover jam screw

For transmitter housings shipped with a cover jam screw, as shown in [Figure 3-44](#), the screw should be properly installed once the transmitter has been wired and powered up. The cover jam screw is intended to disallow the removal of the transmitter cover in flameproof environments without the use of tooling.

Procedure

1. Verify the cover jam screw is completely threaded into the housing.
2. Install the transmitter housing cover and verify that the cover is tight against the housing.
3. Using an M4 hex wrench, loosen the jam screw until it contacts the transmitter cover.
4. Turn the jam screw an additional $\frac{1}{2}$ turn counterclockwise to secure the cover.

NOTICE

Application of excessive torque may strip the threads.

5. Verify the cover cannot be removed.

Figure 3-44: Cover Jam Screw

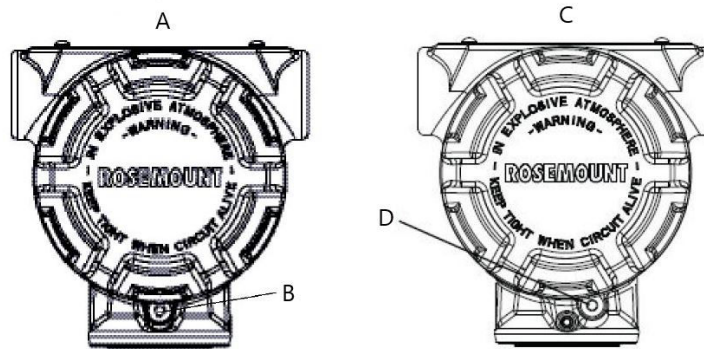

- A. Plantweb housing
- B. 2x cover jam screw (1 per side)
- C. Junction box housing
- D. Cover jam screw

4 Operation and maintenance

This section contains information on commissioning and operating Rosemount™ 3051S Pressure Transmitters. Tasks that should be performed on the bench prior to installation are explained in this section.

Field Communicator and AMS Device Manager instructions are given to perform configuration functions. For convenience, Field Communicator Fast Key sequences are labeled Fast Keys for each software function below the appropriate headings.

4.1 Calibration for HART® Protocol

Calibrating a Rosemount 3051S Transmitter may include the following procedures:

Rerange: Sets the 4 and 20 mA points at required pressures.

Sensor trim: Adjusts the position of the factory sensor characterization curve to optimize performance over a specified pressure range, or to adjust for mounting effects.

Analog output trim: Adjusts the analog output to match the plant standard or the control loop.

The Rosemount 3051S SuperModule™ uses a microprocessor that contains information about the sensor's specific characteristics in response to pressure and temperature inputs. A smart transmitter compensates for these sensor variations. The process of generating the sensor performance profile is called factory sensor characterization. Factory sensor characterization also provides the ability to readjust the 4 and 20 mA points without applying pressure to the transmitter.

Trim and rerange functions also differ. Reranging sets analog output to the selected upper and lower range points and can be done with or without an applied pressure. Reranging does not change the factory sensor characterization curve stored in the microprocessor. Sensor trimming requires an accurate pressure input and adds additional compensation that adjusts the position of the factory sensor characterization curve to optimize performance over a specific pressure range.

Note

Sensor trimming adjusts the position of the factory sensor characterization curve. It is possible to degrade performance of the transmitter if the trim is done improperly or with inaccurate equipment.

Table 4-1: Recommended Calibration Tasks

Transmitter	Bench calibration tasks	Field calibration tasks
Rosemount 3051S_CD, 3051S_CG, 3051S_SAL, 3051S_SAM, 3051S_TG, Range 1-4	<ol style="list-style-type: none"> 1. Set output configuration parameters: <ol style="list-style-type: none"> a. Set the range points. b. Set the output units. c. Set the output type. d. Set the damping value. <ul style="list-style-type: none"> • Optional: Perform a sensor trim (accurate pressure source required). • Optional: Perform an analog output trim (accurate multimeter required). 	<ul style="list-style-type: none"> • Reconfigure parameters if necessary. • Zero trim the transmitter to compensate for mounting effects or static pressure effects.
Rosemount 3051S_CA, 3051S_TA, 3051S_TG, Range 5	<ol style="list-style-type: none"> 1. Set output configuration parameters: <ol style="list-style-type: none"> a. Set the range points. b. Set the output units. c. Set the output type. d. Set the damping value. <ul style="list-style-type: none"> • Optional: Perform a sensor trim if equipment available (accurate absolute pressure source required). Otherwise, perform the low trim value section of the sensor trim procedure. • Optional: Perform an analog output trim (accurate multimeter required). 	<ul style="list-style-type: none"> • Reconfigure parameters if necessary. • Perform low trim value section of the sensor trim procedure to correct for mounting position effects.

Note

A Field Communicator is required for all sensor and output trim procedures. 3051S_C Range 4 and Range 5 Transmitters require a special calibration procedure when used in differential pressure applications under high static line pressure. 3051S_TG Range 5 Transmitters use an absolute sensor that requires an accurate absolute pressure source to perform the optional sensor trim.

Related information

[Compensating for line pressure \(Range 4 and 5\)](#)

4.1.1 Calibration overview

Complete calibration of the Rosemount 3051S involves the following tasks:

Configure the analog output parameters

- Set **Process Variable Units**
- Set **Output Type**

- **Rerange**
- Set **Damping**

Calibrate the sensor

- **Sensor Trim**
- **Zero Trim**

Calibrate the 4–20 mA output

- **4–20 mA Output Trim**; or
- **4–20 mA Output Trim Using Other Scale**

Data flow

Not all calibration procedures should be performed for each transmitter. Some procedures are appropriate for bench calibration, but should not be performed during field calibration. [Table 4-1](#) identifies the recommended calibration procedures for each type of transmitter for bench or field calibration. Data flow can be summarized in four major steps:

1. A change in pressure is measured by a change in the sensor output (sensor signal).
2. The sensor signal is converted to a digital format that is understood by the microprocessor (analog-to-digital signal conversion).
3. Corrections are performed in the microprocessor to obtain a digital representation of the process input (digital PV).
4. The Digital Primary Variable (PV) is converted to an analog value (Digital-to-Analog signal conversion).

4.1.2 Determining calibration frequency

Calibration frequency can vary greatly depending on the application, performance requirements, and process conditions.

Procedure

1. Determine the performance required for your application.
2. Determine the operating conditions.
3. Calculate the Total Probable Error (TPE).
4. Calculate the stability per month.
5. Calculate the calibration frequency.

Sample calculation

Procedure

1. Determine the performance required for your application.

Required performance	0.30 percent of span
-----------------------------	----------------------

2. Determine the operating conditions.

Transmitter	Rosemount 3051S_CD, range 2A [Upper range value URV = 250 inH ₂ O (623 mbar)], classic performance
Calibrated span	150 inH ₂ O (374 mbar)
Ambient temperature change	± 50 °F (28 °C)
Line pressure	500 psig (34.5 bar)

3. Calculate Total Probable Error (TPE).

Example

$$\text{TPE} = \frac{\sqrt{(\text{ReferenceAccuracy})^2 + (\text{TemperatureEffect})^2 + (\text{StaticPressureEffect})^2}}{\text{span}} = 0.112\% \text{ of span}$$

Where:

Reference accuracy = ± 0.055% of span

Ambient temperature effect =

$$\pm \left(\frac{0.0125 \times \text{URL}}{\text{Span}} + 0.0625 \right) \text{ per } 50 \text{ }^\circ\text{F} = \pm 0.0833\% \text{ of span}$$

Span static pressure effect ⁽⁵⁾=

$$0.1\% \text{ reading per } 1000 \text{ psi (69 bar)} = \pm 0.05\% \text{ of span at maximum span}$$

4. Calculate the stability per month.

Example

$$\text{Stability} = \pm \left[\frac{0.125 \times \text{URL}}{\text{Span}} \right] \% \text{ of span for 5 years} = \pm 0.0035\% \text{ of span per month}$$

5. Calculate calibration frequency.

Example

$$\text{Cal. Freq.} = \frac{(\text{Req. performance} - \text{TPE})}{\text{Stability per month}} = \frac{(0.3 - 0.112\%)}{0.0035\%} = 54 \text{ months}$$

4.1.3 Selecting a trim procedure

Prerequisites

To decide which trim procedure to use, you must first determine whether the analog-to-digital section or the digital-to-analog section of the transmitter electronics needs trimming.

⁽⁵⁾ Zero static pressure effect removed by zero trimming at line pressure.

Procedure

1. Connect a pressure source, a Field Communicator or AMS Device Manager, and a digital readout device to the transmitter.
2. Establish communication between the transmitter and the Field Communicator.
3. Apply pressure equal to the upper range point pressure.
4. Compare the applied pressure to the pressure process variable value.
 - On the Field Communicator, access the pressure process variable value on the **Process Variables** menu.
 - On the AMS Device Manager, access the pressure process variable on the **Process Variables** screen.

If the pressure reading does not match the applied pressure (with high-accuracy test equipment), perform a sensor trim. See [Process variables](#) to determine which trim to perform.

For instructions on how to access process variables, see [Sensor trim overview](#).

5. Compare the Analog Output (AO) line, on the Field Communicator or AMS Device Manager, to the digital readout device.

If the AO reading does not match the digital readout device (with high-accuracy test equipment), perform an analog output trim. See [Analog output trim](#).

4.1.4 Sensor trim overview

Trim the sensor using either sensor or zero trim functions. Trim functions vary in complexity and are application-dependent. Both trim functions alter the transmitter's interpretation of the input signal.

Zero trim is a single-point offset adjustment. It is useful for compensating for mounting position effects and is most effective when performed with the transmitter installed in its final mounting position. Since this correction maintains the slope of the characterization curve, it should not be used in place of a sensor trim over the full sensor range.

When performing a zero trim with a manifold, refer to [Manifold operation](#).

Note

Do not perform a zero trim on Rosemount 3051S Absolute Pressure Transmitters. Zero trim is zero based, and absolute pressure transmitters reference absolute zero. To correct mounting position effects on an absolute pressure transmitter, perform a low trim within the sensor trim function. The low trim function provides an offset correction similar to the zero trim function, but it does not require zero-based input.

Sensor trim is a 2-point sensor calibration where two end-point pressures are applied, and all output is linearized between them. Always adjust the low trim value first to establish the correct offset. Adjustment of the high trim value provides a slope correction to the characterization curve based on the low trim value. The trim values allow you to optimize performance over your specified measuring range at the calibration temperature.

4.1.5 Zero trim

Device Dashboard Fast Keys	3, 4, 1, 3
HART 5 with Diagnostics Fast Keys	3, 4, 1, 1, 1, 3
HART 7 Fast Keys	3, 4, 1, 1, 1, 3

Note

The transmitter must be within three percent of true zero (zero-based) in order to calibrate with zero trim function.

Calibrate the sensor with the Field Communicator Zero Trim Function

Calibrate the sensor with a Field Communicator using the zero trim function.

Procedure

1. Vent the transmitter and attach a Field Communicator to the measurement loop.
2. From the **Home** screen, follow the Fast Key sequence **Zero Trim**.
3. Follow the commands provided by the Field Communicator to complete the zero trim adjustment.

Calibrate the sensor with the AMS Device Manager Zero Trim Method

Procedure

1. Right click on the device and from the menu, select **Methods**.
2. Select **Calibrate**.
3. Select **Zero Trim**.
4. Follow the on-screen prompts.
5. Select **Finish** to acknowledge the method is complete.

4.1.6

Sensor trim

Device Dashboard Fast Keys	3, 4, 1
HART 5 with Diagnostics Fast Keys	3, 4, 1, 1, 1
HART 7 Fast Keys	3, 4, 1, 1, 1

Note

Use a pressure input source that is at least four times more accurate than the transmitter, and allow the input pressure to stabilize for 10 seconds before entering any values.

Calibrate the Field Communicator with the Sensor Trim Function

Calibrate the sensor with a Field Communicator using the sensor trim function.

Procedure

1. Assemble and power the entire calibration system including a transmitter, Field Communicator, power supply, pressure input source, and readout device.
2. From the **Home** screen, enter the Fast Key sequence **Sensor Trim**.
3. Select **2: Lower Sensor Trim**. The lower sensor trim value should be the sensor trim point that is closest to zero.

Note

Select pressure input values so that lower and upper values are equal to or outside the 4 and 20 mA points. Do not attempt to obtain reverse output by reversing the

high and low points. This can be done by going to [Rerange](#). The transmitter allows approximately five percent deviation.

4. Follow the commands provided by the Field Communicator to complete the adjustment of the lower value.
5. Repeat [Step 2](#) and [Step 3](#) for the upper value. In Step 3, select **3: Upper Sensor Trim**.

Calibrate the Transmitter with the AMS Device Manager Sensor Trim Method

Procedure

1. Right click on the device and select **Methods** → **Calibrate** → **Sensor Trim** from the menu.
2. Select **Lower Sensor Trim**.
3. Follow on-screen prompts.
4. Select **Finish** to acknowledge the method is complete.
5. Right click on the device and select **Methods** → **Calibrate** → **Sensor Trim** from the menu.
6. Select **Upper Sensor Trim** and repeat steps 3-4.

4.1.7

Recall factory trim – Sensor trim

Device Dashboard Fast Keys	3, 4, 3
HART 5 with Diagnostics Fast Keys	3, 4, 1, 3, 1
HART 7 Fast Keys	3, 4, 1, 3, 1

The recall factory trim–sensor trim command allows the restoration of the as-shipped factory settings of the sensor trim. This command can be useful for recovering from an inadvertent zero trim of an absolute pressure unit or inaccurate pressure source.

Recall Factor Trim on a Field Communicator

Enter the Fast Key sequence **Recall Factory Trim–Sensor Trim**.

Recall Factory Trim on AMS Device Manager

Recall factory sensor trim on the AMS Device Manager.

Procedure

1. Right click on the device and select **Methods** → **Calibrate** → **Recall Factory Trim** from the menu.
2. Set the control loop to Manual. Select **Next**.
3. To recall the factory trim settings, on the **Trim to recall** menu, select **Sensor trim** and then select **Next**.
4. Follow the on-screen prompts.
5. To acknowledge the method is complete, select **Finish**.

4.1.8 Analog output trim

The **analog output trim** commands allow you to adjust the transmitter's current output at the 4 and 20 mA points to match the plant standards. This command adjusts the Digital-to-Analog signal conversion.

4.1.9 Digital-to-Analog trim

Device Dashboard Fast Keys	3, 4, 2
HART 5 with Diagnostics Fast Keys	3, 4, 1, 2, 3
HART 7 Fast Keys	3, 4, 1, 2, 3, 1

Perform a Digital-to-Analog Trim with a Field Communicator

Procedure

1. From the **Home** screen, enter the Fast Key sequence **Digital-to-Analog Trim**.
2. Select **OK** after setting the control loop to **Manual**.
See [Setting the loop to Manual](#).
3. At the **Connect reference meter** prompt, connect an accurate reference milliamp meter to the transmitter.
 - a) Connect the positive lead to the positive terminal.
 - b) Connect the negative lead to the test terminal in the transmitter terminal compartment.
4. Select **OK** after connecting the reference meter.
5. At the `Setting fld dev output to 4 mA` prompt, select **OK**.
The transmitter outputs 4.0 mA.
6. Record the actual value from the reference meter, and enter it at the `ENTER METER VALUE` prompt.
The Field Communicator prompts you to verify whether or not the output value equals the value on the reference meter.
7. Select an option.
 - If the reference meter value equals the transmitter output value, select **1: Yes**.
 - If the reference meter value does not equal the transmitter output value, select **2: No** and repeat [Step 6](#).
8. At the `Setting fld dev output to 20 mA` prompt, select **OK**. Repeat [Step 5](#) and [Step 6](#) until the reference meter value equals the transmitter output value.
9. Select **OK** after the control loop is returned to **Automatic** control.

Calibrate the Transmitter using the AMS Device Manager Digital-to-Analog Trim Method

Procedure

1. Right click on the device and select **Methods** → **Calibrate** → **D/A Trim** from the menu.
2. Follow the on-screen prompts.
3. Select **Finish** to acknowledge the method is complete.

4.1.10 Digital-to-Analog trim using other scale

Device Dashboard Fast Keys	3, 4, 2, 2
HART 5 with Diagnostics Fast Keys	N/A
HART 7 Fast Keys	3, 4, 1, 2, 3, 2

The **scaled D/A trim** command matches the 4 and 20 mA points to a user selectable reference scale other than 4 and 20 mA (such as, 1–5 volts if measuring across a 250 ohm load, or 0–100 percent if measuring from a distributed control system [DCS]). To perform a scaled D/A trim, connect an accurate reference meter to the transmitter and trim the output signal to scale, as outlined in the output trim procedure.

Note

Use a precision resistor for optimum accuracy. If you add a resistor to the loop, ensure that the power supply is sufficient to power the transmitter to a 23 mA output (maximum alarm value) with additional loop resistance.

Perform a scaled D/A Trim using a Field Communicator

Enter the Fast Key sequence **Digital-to-Analog Trim Using Other Scale**.

Perform a scaled D/A Trim method on AMS Device Manager

Procedure

1. Right click on the device and select **Methods** → **Calibrate** → **Scaled D/A trim** from the menu.
2. Set the control loop to **Manual**. Select **Next**.
3. To change the scale, select **Change** and then select **Next**.
4. Follow the on-screen prompts.
5. To acknowledge the method is complete, select **Finish**.

4.1.11 Recall factory trim – Analog output

Device Dashboard Fast Keys	3, 4, 3
HART 5 with Diagnostics Fast Keys	3, 4, 1, 3, 2
HART 7 Fast Keys	3, 4, 1, 3, 2

The recall factory trim–analog output command allows the restoration of the as-shipped factory settings of the analog output trim. This command can be useful for recovering from an inadvertent trim, incorrect plant standard, or faulty meter.

Recall factory trim using a Field Communicator

Enter the Fast Key sequence **Recall Factory Trim—Analog Output**.

Recall factory trim on AMS Device Manager

Recall factory analog output trim on the AMS Device Manager.

Procedure

1. Right click on the device and select **Methods** → **Calibrate** → **Recall Factory Trim** from the menu.

2. Set the control loop to **Manual**. Select **Next**.
3. To recall the factory trim settings, on the **Trim to recall** menu, select **Analog output trim** and then select **Next**.
4. Follow the on-screen prompts.
5. To acknowledge the method is complete, select **Finish**.

4.1.12 Line pressure effect (Range 2 and 3)

The following specifications show the static pressure effect for the Rosemount 3051S Range 2 and 3 Pressure Transmitters used in differential pressure applications where line pressure exceeds 2,000 psi (138 bar).

Zero effect Ultra and Ultra for Flow
 $\pm 0.05\%$ of the upper range limit plus an additional $\pm 0.1\%$ of upper range limit error for each 1,000 psi (69 bar) of line pressure above 2,000 psi (138 bar).
Classic
 $\pm 0.1\%$ of the upper range limit plus an additional $\pm 0.1\%$ of upper range limit error for each 1,000 psi (69 bar) of line pressure above 2,000 psi (138 bar).
Example: Line pressure is 3,000 psi (207 bar) for Ultra performance transmitter. Zero effect error calculation:
 $\pm \{0.05 + 0.1 \times [3 - 2 \text{ kpsi}]\} = \pm 0.15\%$ of the upper range limit

Span effect

Refer to [3051S Series of Instrumentation Product Data Sheet](#).

4.1.13 Compensating for line pressure (Range 4 and 5)

The Rosemount 3051S Range 4 and 5 Pressure Transmitters require a special calibration procedure when used in differential pressure applications. The purpose of this procedure is to optimize transmitter performance by reducing the effect of static line pressure in these applications. The 3051S Differential Pressure Transmitters (Ranges 0, 1, 2, and 3) do not require this procedure, because optimization occurs in the sensor.

Applying high static pressure to the 3051S Range 4 and 5 Pressure Transmitters causes a systematic shift in the output. This shift is linear with static pressure; correct it by performing the [Sensor trim](#) procedure.

The following specifications show the static pressure effect for the 3051S Range 4 and 5 Transmitters used in differential pressure applications:

Zero effect

$\pm 0.1\%$ of the upper range limit per 1,000 psi (69 bar) for line pressures from 0 to 2,000 psi (0 to 138 bar)

For line pressures above 2,000 psi (138 bar), the zero effect error is $\pm 0.2\%$ of the upper range limit plus an additional $\pm 0.2\%$ of upper range limit error for each 1,000 psi (69 bar) of line pressure above 2,000 psi (138 bar).

Example: Line pressure is 3,000 psi (207 bar). Zero effect error calculation:

$\pm \{0.2 + 0.2 \times [3 \text{ kpsi} - 2 \text{ kpsi}]\} = \pm 0.4\%$ of the upper range limit

Span effect

Correctable to $\pm 0.2\%$ of reading per 1,000 psi (69 bar) for line pressures from 0 to 3,626 psi (0 to 250 bar)

The systematic span shift caused by the application of static line pressure is -0.85% of reading per 1,000 psi (69 bar) for Range 4 transmitters, and -0.95% of reading per 1,000 psi (69 bar) for Range 5 transmitters.

Use the following example to compute corrected input values.

Example

A transmitter with model number 3051S_CD4 will be used in a differential pressure application where the static line pressure is 1,200 psi (83 bar). The transmitter output is ranged with 4 mA at 500 inH₂O (1.2 bar) and 20 mA at 1500 inH₂O (3.7 bar).

To correct for systematic error caused by high static line pressure, first use the following formulas to determine corrected values for the low trim and high trim.

$$LT = LRV + S \times (LRV) \times P$$

Where:

LT =	Corrected low trim value
LRV =	Lower range value
S =	-(Span shift per specification)
P =	Static line pressure

$$HT = URV + S \times (URV) \times P$$

Where:

HT =	Corrected high trim value
URV =	Upper range value
S =	-(Span shift per specification)
P =	Static line pressure

In this example:

URV =	1500 inH ₂ O (3.74 bar)
LRV =	500 inH ₂ O (1.25 bar)
P =	1200 psi (82.74 bar)
S =	± 0.01/1000

To calculate the low trim (LT) value:

LT =	500 + (0.01/1000)(500)(1200)
LT =	506 inH ₂ O (1.26 bar)

To calculate the high trim (HT) value:

HT =	1500 + (0.01/1000)(1500)(1200)
HT =	1518 inH ₂ O (3.78 bar)

Complete a sensor trim and enter the corrected values for Low Trim (LT) and High Trim (HT). Refer to [Sensor trim](#).

Enter the corrected input values for low trim and high trim through the Field Communicator keypad after you apply the value of pressure as the transmitter input.

Note

After sensor trimming Rosemount 3051S Range 4 and 5 Transmitters for high differential pressure applications, verify the 4 and 20 mA points are at the correct values using the Field Communicator. For the example above, this would be 500 and 1500 respectively. The

zero effect can be eliminated by doing a zero sensor trim at line pressure after installation without affecting the completed calibration.

4.1.14 Diagnostic messages

In addition to output, the LCD displays abbreviated operation, error, and warning messages for troubleshooting. Messages appear according to their priority; normal operating messages appear last. To determine the cause of a message, use a Field Communicator or AMS Device Manager to further interrogate the transmitter. A description of each LCD display diagnostic message follows.

Error indicator

An error indicator message appears on the LCD display to warn of serious problems affecting the operation of the transmitter. The meter displays an error message until the error condition is corrected, `ERROR` appears at the bottom of the display, and analog output is driven to the specified alarm level. No other transmitter information is displayed during an alarm condition.

Fail Module

The SuperModule™ is malfunctioning. Possible sources of problems include:

- Pressure or temperature updates are not being received in the SuperModule.
- A non-volatile memory fault that will affect transmitter operation has been detected in the module by the memory verification routine.
- Some non-volatile memory faults are user-repairable. Use a Field Communicator or AMS Device Manager to diagnose the error and determine if it is repairable. Any error message that ends in `Factory` is not repairable. In cases of non-user-repairable errors, replace the SuperModule. See [Disassembly procedures](#).

Fail configuration

A memory fault has been detected in a location that could affect transmitter operation, and is user-accessible. To correct this problem, use a Field Communicator or AMS Device Manager to interrogate and reconfigure the appropriate portion of the transmitter memory.

Warnings

Warnings appear on the LCD display to alert you of user-repairable problems with the transmitter, or current transmitter operations. Warnings appear alternately with other transmitter information until the warning condition is corrected or the transmitter completes the operation that warrants the warning message.

LCD update error

A communications error has occurred between the LCD display and the SuperModule. Verify the LCD display is firmly seated by squeezing the two tabs, pulling the LCD display out, ensuring the pins are in the feature board and snapping the LCD display back into place. If this does not clear the error, replace the LCD display.

PV limit

The primary variable read by the transmitter is outside of the transmitter's range.

Non PV limit

A non-primary variable read by the transmitter is outside of the transmitter's range.

Curr sat

The primary variable read by the module is outside of the specified range, and the analog output has been driven to saturation levels.

XMRT info

A non-volatile memory fault has been detected in the transmitter memory by the memory verification routine. The memory fault is in a location containing transmitter information. To correct this problem, use a Field Communicator or AMS Device Manager to interrogate and reconfigure the appropriate portion of the transmitter memory. This warning does not affect the transmitter operation.

Press alert

A HART alert when the pressure variable read by the transmitter is outside of the user set alert limits.

Temp alert

A HART alert when the sensor temperature variable read by the transmitter is outside of the user set alert limits.

Operation

Normal operation messages appear on the LCD display to confirm actions or inform you of transmitter status. Operation messages are displayed with other transmitter information and warrant no action to correct or alter the transmitter settings.

Loop test

A loop test is in progress. During a loop test or 4–20 mA trim, the analog output is set to a fixed value. The meter display alternates between the current selected in milliamps and LOOP TEST.

The zero value, set with the local zero adjustment button, has been accepted by the transmitter, and the output should change to 4 mA.

The zero value, set with the local zero adjustment button, exceeds the maximum rangedown allowed for a particular range, or the pressure sensed by the transmitter exceeds the sensor limits.

The span value, set with the local span adjustment button, has been accepted by the transmitter, and the output should change to 20 mA.

The span value, set with the local span adjustment button, exceeds the maximum rangedown allowed for a particular range, or the pressure sensed by the transmitter exceeds the sensor limits.

This message appears during reranging with the integral zero and span buttons and indicates that the transmitter local zero and span adjustments have been disabled. The adjustments have been disabled by software commands from the Field Communicator or AMS Device Manager. Keys are disabled when write protect jumper is **ON**. If alarm and security adjustments are not installed, the transmitter will operate normally with the default alarm condition alarm high and the security off.

Stuck key

The zero or span button is stuck in the depressed state or pushed too long.

4.2 Field upgrades

4.2.1 Labeling

Each housing and each SuperModule is labeled individually, so it is imperative that the approval codes on each label match exactly during upgrade. The label on the SuperModule reflects the replacement model code for reordering an assembled unit. The housing labeling will only reflect the approvals and communication protocol of the housing.

4.2.2 Upgrading electronics

The Plantweb™ housing allows for electronics upgrades. Different electronics assemblies provide new functionality and are easily interchanged for upgrade. Keyed slots guide the assemblies into place, and assemblies are secured with two provided screws.

Hardware adjustments

The D1 option is available for local hardware adjustments. This option is available for both the Plantweb and Junction Box housings. In order to use zero, span, alarm and security functions, replace the existing Plantweb assembly with the Hardware Adjustment Interface Assembly (p/n 03151-9017-0001). Install the LCD display or hardware adjustment module to activate the hardware adjustments.

Advanced HART® diagnostics

The DA2 option is available for Advanced HART Diagnostics. This option requires the use of the Plantweb housing. In order to gain full access to the Advanced HART Diagnostic capabilities, simply add the 3051S HART Diagnostics Electronics assembly (p/n 03151-9071-0001). Before replacing the existing assembly with the new 3051S Diagnostics Electronics assembly, record the transmitter configuration. Transmitter configuration data must be reentered after adding the Advanced HART Diagnostics electronics assembly and before putting the transmitter back into operation.

FOUNDATION™ Fieldbus

FOUNDATION Fieldbus Upgrade Kits are available for Plantweb housings. Each kit includes an electronics assembly and terminal block. To upgrade to FOUNDATION Fieldbus, replace the existing electronics assembly with the FOUNDATION Fieldbus Output Electronics assembly (P/N 03151-9020-0001) and replace the existing terminal block with the FOUNDATION Fieldbus terminal block (part number will vary based on the kit selected). [Table 4-2](#) shows the available kits.

Table 4-2: FOUNDATION Fieldbus Upgrade Kits

Kit	Part number
Standard FOUNDATION Fieldbus Upgrade kit	03151-9021-0021
Transient Protection FOUNDATION Fieldbus Upgrade kit	03151-9021-0022
FISCO FOUNDATION Fieldbus Upgrade kit	03151-9021-0023

Refer to [Disassembly procedures](#) for information on assembly.

5 Troubleshooting

5.1 Disassembly procedures

5.1.1 Remove from service

Procedure

1. Follow all plant safety rules and procedures.
2. Power down device.
3. Isolate and vent the process from the transmitter before removing the transmitter from service.
4. Remove all electrical leads and disconnect conduit.
5. Remove the transmitter from the process connection, if applicable.
 - The Rosemount 3051S Coplanar transmitter is attached to the process connection by four bolts and two cap screws. Remove the bolts and screws and separate the transmitter from the process connection. Leave the process connection in place and ready for re-installation.
 - The Rosemount 3051S In-Line transmitter is attached to the process connection by a single hex nut process connection. Loosen the hex nut to separate the transmitter from the process connection.

NOTICE

Do not wrench on neck of transmitter.

6. Clean isolating diaphragms with a soft rag and a mild cleaning solution, and rinse with clean water.

NOTICE

Do not scratch, puncture, or depress the isolating diaphragms.

7. For the 3051S Coplanar transmitter, whenever you remove the process flange or flange adapters, visually inspect the PTFE o-rings. Replace the O-rings if they show any signs of damage, such as nicks or cuts. Undamaged o-rings may be reused.

5.1.2 Remove terminal block

Electrical connections are located on the terminal block (see [Table 5-1](#)) in the compartment labeled FIELD TERMINALS.

Plantweb™ housing

1. Loosen the two small screws located at the 10 o'clock and 4 o'clock positions.
2. Pull the entire terminal block out.

Junction Box housing

1. Loosen the two small screws located at the 8 o'clock and 4 o'clock positions.

2. Pull the entire terminal block out.

This procedure will expose the SuperModule™ connector. See [Table 5-1](#).

Terminal blocks

Table 5-1: Terminal blocks

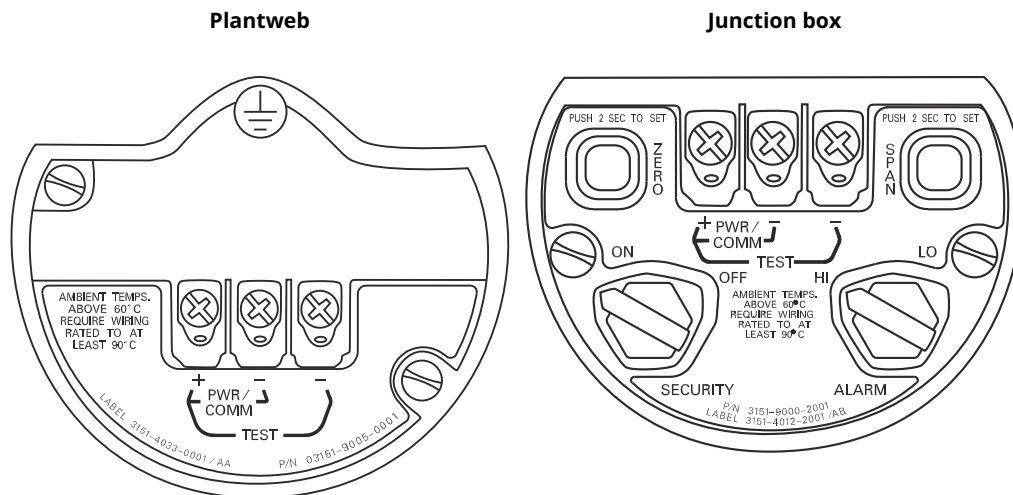

5.1.3 Remove interface assembly

The Standard Interface Assembly, Adjustment Interface Assembly, Safety Certified Electronics Assembly (6), or HART® Diagnostics Electronics Assembly (7) is located in the compartment opposite the terminal side in the Plantweb housing. To remove the assembly, perform the following procedure:

Procedure

1. Remove the housing cover opposite the field terminal side.
2. Remove the LCD display or adjustment module, if applicable. To do this, hold in the two clips and pull outward.
This will provide better access to the two screws located on the Standard Interface Assembly, Adjustment Interface Assembly, Safety Certified Electronics Assembly, or HART Diagnostics Electronics Assembly.
3. Loosen the two small screws located on the assembly in the 8 o'clock and 2 o'clock positions.
4. Pull out the assembly to expose and locate the SuperModule connector. .
See [Figure 5-1](#)
5. Grasp the SuperModule connector and push in the two tabs at the point where they meet the SuperModule and pull upwards (avoid pulling wires.)
Housing rotation may be required to access locking tabs. (8)

(6) This assembly has yellow casing.

(7) This assembly has black casing with a white label.

(8) Plantweb housing only.

Example

Figure 5-1: SuperModule Connector View

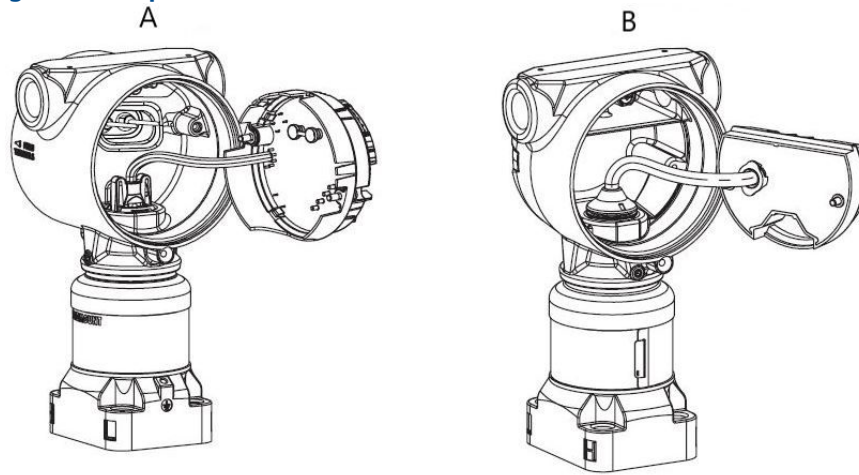

- A. *Plantweb*
- B. *Junction box*

5.1.4 Remove the SuperModule from the housing

Procedure

1. Loosen the housing rotation set screw with a 3/32-in. hex wrench and then rotate back one full turn.
See [Table 5-2](#).
2. Unscrew the housing from the SuperModule™.

Table 5-2: Set Screw Location

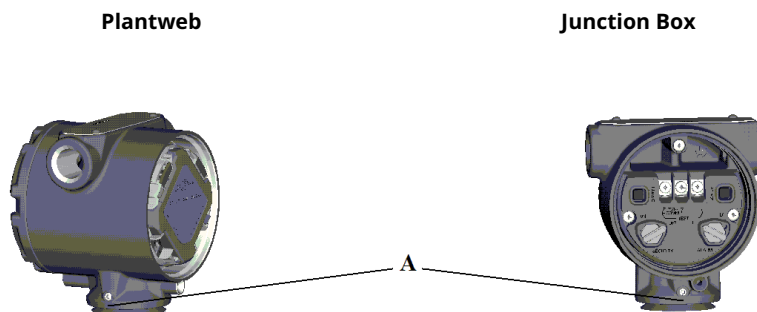

- A. Set screw (3/32-in.)

⚠ CAUTION

To prevent damage to the SuperModule cable, disconnect it from the Plantweb assembly or Junction box terminal block before you remove the SuperModule from the housing.

5.2 Reassembly procedures

Note

The V-seal must be installed at the bottom of the housing.

5.2.1 Attach SuperModule™ to Plantweb or Junction box housing

Procedure

1. Apply a light coat of low temperature silicon grease to the SuperModule threads and O-ring.
2. Thread the housing completely onto the SuperModule.

⚠ WARNING

The housing must be no more than one full turn from flush with the SuperModule to comply with explosion-proof requirements.

3. Tighten the housing rotation set screw using a $\frac{3}{32}$ -in. hex wrench.

5.2.2 Install interface assembly in the Plantweb™ housing

Procedure

1. Apply a light coat of low temperature silicon grease to the SuperModule™ connector.
2. Insert the SuperModule connector into the top of the SuperModule.
3. Gently slide the assembly into the housing, ensuring the pins from the Plantweb housing properly engage the receptacles on the assembly.
4. Tighten the captive mounting screws.
5. Attach the Plantweb housing cover and tighten so that metal contacts metal to meet explosion-proof requirements.

5.2.3 Install the terminal block

Install the terminal block in Plantweb™ housing

Procedure

1. Gently slide the terminal block into the housing, making sure the pins from the Plantweb housing properly engage the receptacles on the terminal block.
2. Tighten the captive screws on the terminal block.
3. Attach the Plantweb housing cover and tighten so that metal contacts metal to meet explosion-proof requirements.

Install the terminal block in junction box housing

Procedure

1. Apply a light coat of low temperature silicon grease to the SuperModule™ connector.
2. Insert the SuperModule connector into the top of the SuperModule.
3. Push the terminal block into the housing and hold for screw position alignment.
4. Tighten the captive mounting screws.
5. Attach the junction box housing cover and tighten so that metal contacts metal to meet explosion-proof requirements.

If the installation uses a manifold, see [Rosemount 304, 305, and 306 Manifolds](#) .

5.2.4 Reassemble the process flange

Procedure

1. Inspect the SuperModule™ PTFE O-rings. If the O-rings are undamaged, Emerson recommends reusing them. If the O-rings are damaged (if they have nicks or cuts, for example), replace them with new O-rings.

NOTICE

When replacing O-rings, be careful not to scratch or deface the O-ring grooves or the surface of the isolating diaphragm when removing the damaged O-rings.

2. Install the process flange on the SuperModule. To hold the process flange in place, install the two alignment screws to finger-tight (screws are not pressure retaining).

NOTICE

Do not overtighten; this will affect module-to-flange alignment.

3. Install the appropriate flange bolts:
 - a) If the installation requires a ¼-18 NPT connection(s), use four 1.75-in. flange bolts. Go to [Step d](#).
 - b) If the installation requires a ½-14 NPT connection(s), use four 2.88-in. process flange/adaptor bolts. For gauge pressure configurations, use two 2.88-in. bolts and two 1.75-in. bolts. Go to [Step c](#).
 - c) Hold the flange adapters and adaptor O-rings in place while finger-tightening the bolts.
 - d) Finger-tighten the bolts.
4. Tighten the bolts to the initial torque value using a crossed pattern. See [Table 5-3](#) for appropriate torque values.
5. Tighten the bolts to the final torque value using a crossed pattern. When fully tightened, the bolts should extend through the top of the module housing. If the installation uses a conventional manifold, then install flange adapters on the process end of the manifold using the 1.75-in. flange bolts supplied with the transmitter.

Table 5-3: Bolt Installation Torque Values

Bolt material	Initial torque value	Final torque value
CS-ASTM-A449 Standard	300 in-lb (34 N-m)	650 in-lb (73 N-m)
316 SST—Option L4	150 in-lb (17 N-m)	300 in-lb (34 N-m)
ASTM-A-193-B7M—Option L5	300 in-lb (34 N-m)	650 in-lb (73 N-m)
Alloy K-500 —Option L6	300 in-lb (34 N-m)	650 in-lb (73 N-m)
ASTM-A-453-660—Option L7	150 in-lb (17 N-m)	300 in-lb (34 N-m)
ASTM-A-193-B8M—Option L8	150 in-lb (17 N-m)	300 in-lb (34 N-m)

6. If you replaced the PTFE SuperModule O-rings, re-torque the flange bolts after installation to compensate for cold flow.
7. Install the drain/vent valve:
 - a) Apply sealing tape to the threads on the seat. Starting at the base of the valve with the threaded end pointing toward the installer, apply two clockwise turns of sealing tape.
 - b) Take care to place the opening on the valve so that process fluid will drain toward the ground and away from human contact when the valve is opened.
 - c) Tighten the drain/vent valve to 250 in-lb (28.25 N-m).

Postrequisites

After replacing O-rings on Range 1 Transmitters and re-installing the process flange, expose the transmitter to a temperature of +185 °F (85 °C) for two hours. Then re-tighten the flange bolts in a cross pattern, and again expose the transmitter to a temperature of 185 °F (85 °C) for two hours before calibration.

6 Safety Instrumented Systems (SIS)

The safety-critical output of the Rosemount™ 3051S pressure Transmitter is provided through a two-wire, 4–20 mA signal representing pressure. The 3051S safety certified pressure transmitter is certified to:

- Low and high demand: Type B element
- Route 2H, Low Demand application: SIL 2 for random integrity at HFT=0, Safety Integrity Level (SIL) 3 for random integrity at HFT=1
- Route 2H, High Demand application: SIL 2 and SIL3 for random integrity at HFT=1
- Route 1H where the SFF \geq 90%: SIL 2 for random integrity at HFT=0, SIL 3 for random integrity at HFT=1
- SIL 3 for systematic integrity

6.1 Rosemount 3051S safety certified identification

All 3051S transmitters must be identified as safety certified before installing into Safety Instrumented Systems (SIS).

Procedure

1. Check NAMUR Software Revision located on the metal device tag: SW_ . _ . _ .
3051S Software Rev: 7 or above 3051S with Advanced Diagnostics (option code DA2)
Software Rev: 7 or 8
2. Verify that the option code QT is included in the transmitter model code.
3. Devices used in safety applications with ambient temperatures below -40 °F (-40 °C) require option codes QT and BR5 or BR6.

6.2 Installation in SIS applications

⚠ WARNING

Installations must be performed by qualified personnel.

No special installation is required in addition to the standard installation practices outlined in the applicable product manual.

⚠ WARNING

Always ensure a proper seal by installing the electronics housing cover(s) so that metal contacts metal if housing is used.

Environmental and operational limits are available in the product manual.

The loop should be designed so the terminal voltage does not drop below 10.5 Vdc for the Rosemount 3051S, or 12.0 V for the 3051S with Advanced Diagnostics (option code DA2), when the transmitter output is 23.0 mA.

If hardware security switches are installed, the security switch should be in the **ON** position during normal operation. See [Figure 6-4](#).

Note

If hardware security switches are not installed, security should be **ON** in the software to prevent accidental or deliberate change of configuration data during normal operation.

6.3 Configuring in SIS applications

Use any HART® capable configuration tool to communicate with and verify configuration of the transmitter.

Note

Transmitter output is not safety-rated during the following: configuration changes, multidrop, and loop test. Alternative means should be used to ensure process safety during transmitter configuration and maintenance activities.

6.4 Damping

User-selected damping will affect the transmitter's ability to respond to changes in the applied process. The damping value + response time must not exceed the loop requirements.

6.5 Alarm and saturation levels

Distributed Control Systems (DCS) or safety logic solver should be configured to match transmitter configuration. The following figures identify the three alarm levels available and their operation values.

Figure 6-1: Rosemount alarm level

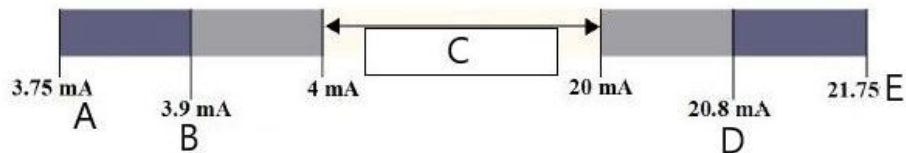

- A. Transmitter failure, hardware or software alarm in Low position
 - B. Low saturation
 - C. Normal operation
 - D. High saturation
 - E. Transmitter failure, hardware or software alarm in High position
-

Figure 6-2: NAMUR alarm level

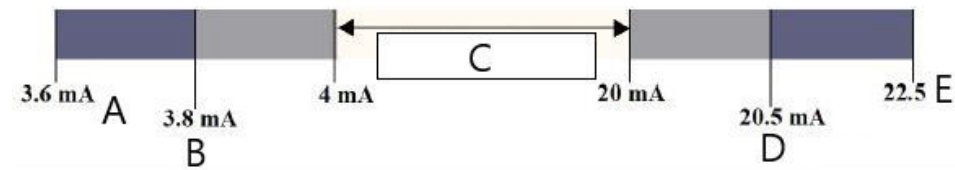

- A. Transmitter failure, hardware or software alarm in Low position
- B. Low saturation
- C. Normal operation
- D. High saturation
- E. Transmitter failure, hardware or software alarm in High position

Figure 6-3: Custom alarm level

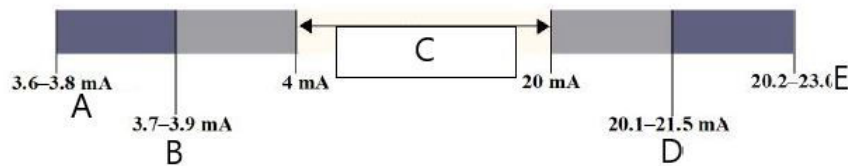

- A. Transmitter failure, hardware or software alarm in Low position
- B. Low saturation
- C. Normal operation
- D. High saturation
- E. Transmitter failure, hardware or software alarm in High position

Setting the alarm values and direction varies whether the hardware switch option is installed. You can use a HART® master or communicator to set the Alarm and Saturation values.

6.5.1 Fast Key Sequence to set Alarm and Saturation values with Switches installed

1. If using a Field Communicator , use the following Fast Key sequence to set the Alarm and Saturation values.

Device Dashboard Fast Keys	1, 4, 5
HART 5 with Diagnostics Fast Keys	2, 2, 2, 5
HART 7 Fast Keys	2, 2, 2, 5

2. Manually set the direction for the Alarm to HI or LO using the ALARM switch as shown in [Figure 6-4](#) .

6.5.2 Fast Key Sequence to set Alarm and Saturation values without Switches installed

1. If using a Field Communicator, use the Switches Installed Fast Key sequence to set the Alarm and Saturation values and the below Fast Key sequence to set the alarm direction:

Device Dashboard Fast Keys	1, 7, 5, 1
HART 5 with Diagnostics Fast Keys	2, 2, 2, 5, 1
HART 7 Fast Keys	2, 2, 2, 5, 1

Figure 6-4: Security and alarm configuration (option D1)

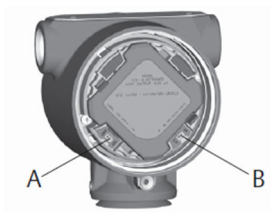

- A. Security
- B. Alarm

6.6 SIS Operation and maintenance

6.6.1 Proof test

Emerson recommends the following proof tests. In the event that an error is found in the safety and functionality, proof test results and corrective actions taken can be documented at [Emerson.com/Measurement-Instrumentation/Safety-Measurement](https://www.emerson.com/Measurement-Instrumentation/Safety-Measurement).

⚠ WARNING

All proof test procedures must be carried out by qualified personnel.

Use Field Communicator menu trees and Fast Keys to perform a loop test, analog output trim, or sensor trim. Security switch should be in the unlocked position during proof test execution and repositioned in the locked position after execution.

6.6.2 Partial proof test, PATC diagnostics not enabled

The simple suggested proof test consists of a power cycle plus reasonability checks of the transmitter output. See Related information for percent of possible DU failures in the device.

Required tools: Field Communicator
mA meter

Procedure

1. Bypass the safety function and take appropriate action to avoid a false trip.
2. Use HART communications to retrieve any diagnostics and take appropriate action.
3. Send a HART command to the transmitter to go to the high alarm current output and verify that the analog current reaches that value⁽⁹⁾.

Note

See [Alarm level verification](#).

4. Send a HART command to the transmitter to go to the low alarm current output and verify that the analog current reaches that value⁽¹⁰⁾.
5. Remove the bypass and otherwise restore normal operation.
6. Place the security switch in the locked position.

Related information

[FMEDA Report](#)

6.6.3 Comprehensive proof test, PATC diagnostics not enabled

The comprehensive proof test consists of performing the same steps as the simple suggested proof test but with a two point verification of the pressure sensor. Reference the [FMEDA Report](#) for percent of possible DU failures in the device.

Required tools:

- Field Communicator
- mA meter
- Pressure calibration equipment

Procedure

1. Bypass the safety function and take appropriate action to avoid a false trip.
2. Use HART communications to retrieve any diagnostics and take appropriate action.
3. Send a HART command to the transmitter to go to the high alarm current output and verify that the analog current reaches that value.
See [Alarm level verification](#).
4. Send a HART command to the transmitter to go to the low alarm current output and verify that the analog current reaches that value.
5. Perform a two-point verification of the sensor (see [Calibration for HART® Protocol](#)) over the full working range and verify the current output at each point.
6. Remove the bypass and otherwise restore normal operation.
7. Place the security switch in the locked position.

The user determines the proof test requirements for impulse piping.

Note

Automatic diagnostics are defined for the corrected % DU: The tests performed internally by the device during runtime without requiring enabling or programming by the user.

⁽⁹⁾ This tests for possible quiescent current related failures.

⁽¹⁰⁾ This tests for compliance voltage problems, such as low loop power supply voltage or increased wiring distance. This also tests for other possible failures.

6.6.4 Comprehensive proof test, PATC diagnostics enabled

Reference the [FMEDA Report](#) for percent of possible DU failures in the device.

Required tools: Field Communicator
Pressure calibration equipment

Procedure

1. Bypass the safety function and take appropriate action to avoid a false trip.
2. Use HART communications to retrieve any diagnostics and take appropriate action.
3. Perform a two-point verification of the transmitter over the full working range.
4. Remove the bypass and otherwise restore normal operation.
5. Place the security switch in the locked position.

When the Loop Integrity and Transmitter Power Consumption diagnostics are enabled and alarm values configured, the testing functionality is described in steps [Step 3](#) and [Step 4](#) of the partial and comprehensive proof test. This eliminates the need for the partial proof test, simplifies the comprehensive proof test, and thereby reduces the total proof test workload.

6.7 Inspection

6.7.1 Product repair

The Rosemount 3051S is repairable by major component replacement.

All failures detected by the transmitter diagnostics or by the proof-test must be reported. Feedback can be submitted electronically at [Emerson.com/Measurement-Instrumentation/Safety-Measurement](https://Emerson.com/Masurement-Instrumentation/Safety-Measurement).

⚠ WARNING

All product repair and part replacement must be performed by qualified personnel.

6.7.2 Rosemount 3051S SIS reference

The 3051S must be operated in accordance to the functional and performance specifications provided in [Appendix A: Specifications and Reference Data](#).

6.7.3 Failure rate data

The FMEDA Report includes failures rates and common cause Beta factor estimates. The most current report is available at Emerson.com/Rosemount/3051S.

6.7.4 Failure values

Transmitter response time: Reference [Rosemount 3051S Series of Instrumentation Product Data Sheet](#).

Self-diagnostics test interval: At least once every 60 minutes

Safety deviation: The percent a failure could drift to be defined as a safe/
dangerous failure is $\pm 2\%$

6.7.5 Product life

50 years: Based on worst case component wear-out mechanisms. Not based on wear-out of process wetted materials derived from the FMEDA.

7 Advanced HART Diagnostic Suite

7.1 Advanced HART[®] Diagnostic Suite

7.1.1 Overview

The Advanced HART[®] Diagnostic Suite is an extension of the Rosemount[™] 3051S Series of Instrumentation and takes full advantage of the scalable architecture. The 3051S SuperModule[™] Platform generates the pressure measurement while the diagnostic electronics board is mounted in the Plantweb[™] housing and plugs into the top of the SuperModule. The electronics board communicates with the SuperModule and produces standard 4–20 mA and HART outputs while adding advanced diagnostic card ability.

Note

When a new SuperModule is connected to the diagnostic electronics board for the first time, the transmitter will be in alarm state until lower and upper range values are specified.

The Advanced HART Diagnostics Suite is designated by the option code DA2 in the model number. All options can be used with DA2 except the following:

- FOUNDATION[™] Fieldbus Protocol (output code F)
- Wireless (output code X)
- Quick Connect (housing code 7J)
- Junction Box (housing code 2A, 2B, 2C, 2J)
- Remote display (housing code 2E, 2F, 2G, 2M)

The HART Diagnostic transmitter has seven distinct diagnostic functions that can be used separately or in conjunction with each other to detect and alert users to conditions that were previously undetectable and to provide powerful troubleshooting tools.

1. **Process Intelligence & Plugged Impulse Line Diagnostics:** The Process Intelligence and Plugged Impulse Line diagnostics are two distinct diagnostics that use the same patented statistical processing technology. Process Intelligence uses this patented technology to detect changes in the process or process equipment. The Plugged Impulse Line diagnostic uses it to detect changes in the installation condition of the transmitter. It works by modeling the process noise signature (using the statistical values of mean, standard deviation, and coefficient of variation) under normal conditions and then analyzing the recorded baseline values to current values over time.

If a significant change in the current values is detected, the transmitter can generate HART alerts or analog alarms, depending on user configuration. The condition is time-stamped and is also noted on LCD display. Configuration of Process Intelligence and the Plugged Impulse Line diagnostics requires the same steps, so these diagnostics will be described together in the following sections.

The statistical values are also available as secondary variables from the transmitter via HART. Users can trend their process noise signature, perform their own analysis or generate their own alarms or alerts based on the secondary variables. Trending of statistical values in an analog system can be done with the Wireless 775 THUM[™] Adapter or Rosemount 333 Tri-Loop[™]. Refer to [Emerson Wireless 775 THUM[™] Adapter Configuration with Advanced Diagnostics](#).

2. **Loop Integrity:** This diagnostic functionality detects changes in the characteristics of the electrical loop that may jeopardize loop integrity. This is done by characterizing the electrical loop after the transmitter is installed and powered up in the field. If terminal voltage deviates outside of user configured limits, the transmitter can generate HART alerts or analog alarms.
3. **Diagnostic Log:** The transmitter logs up to ten device status events, each associated with the time stamp of when the event occurred. Referencing this log allows for better understanding of the device health and can be used in conjunction with device troubleshooting.
4. **Variable Log:** The transmitter logs the following values: Minimum and Maximum Pressure and Minimum and Maximum Temperature with independent time stamped values. The transmitter also logs total elapsed time in over-pressure or over-temperature conditions and the number of pressure or temperature excursions outside of sensor limits.
5. **Process Alerts:** These are configurable alerts for both process pressure and module temperature. Users can receive a HART alert if pressure or module temperature exceeds threshold limits. The time stamp of when the alert occurred and the number of alert events is also recorded in the transmitter. When alert is active, this notification is displayed on the LCD display.
6. **Service Alerts:** This is a configurable service reminder that generates a HART alert after user-specified time has expired. When alert is active, this notification is displayed on the LCD display.
7. **Time Stamp:** The diagnostic electronics board includes an embedded Operational Hours clock whose purpose is two-fold.
Provides the total number of operating hours of the transmitter.
Provides an elapsed **Time Since** event indication or time stamping for all diagnostics.

Note

All time values are non-volatile and displayed in the following format: yy:dd:hh:mm:ss (years:days:hours:minutes:seconds). The time stamping capability significantly enhances the user's ability to troubleshoot measurement issues, particularly transient events that may be too fast to capture with Distributed Control System (DCS) or Programmable Logic Controller (PLC) trending or historian capabilities.

7.1.2 User interface

The Rosemount 3051S with Advanced HART Diagnostic Suite can be used with any asset management software that supports Electronic Device Description Language (EDDL) or FDI/DTM.

Advanced HART Diagnostics is best viewed and configured using the latest Device Dashboard interface based on Human Centered Design concepts. The Device Dashboard can be obtained with DD revision 3051S HDT Dev Rev 4 DD Rev 2.

The following screenshots are taken from Emerson's AMS Device Manager, version 10.5. All screens shown are based on the Device Dashboard interface.

Figure 7-1: Device Dashboard

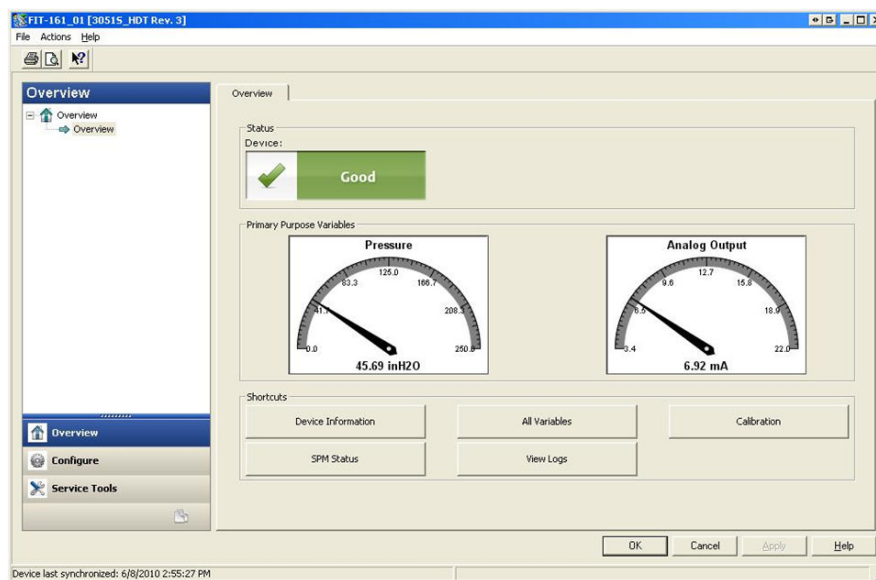

Figure 7-1 is the landing screen for the 3051S with Advanced HART Diagnostic Suite. The device status will change if any device alerts are active. Graphical gauges provide quick reading of the primary purpose variables. Shortcut buttons are available for the most common tasks.

Diagnostic action settings

Each diagnostic allows the user to select a type of action to take if the diagnostic is tripped.

None Transmitter provides no indication that any trip values were exceeded or the diagnostic is turned off.

Alert Unlatched Transmitter generates digital HART alert and does not affect the 4–20 mA signal. When conditions return to normal or within threshold levels, the alert is automatically cleared.

Alert Latched Transmitter generates digital HART alert and does not affect the 4–20 mA signal. When conditions return to normal, an alert reset is required to clear the status. This type of alert action is recommended if a third party alert monitor software is likely to miss alerts due to slow polling of HART data.

Alarm Transmitter drives mA output to the configured Failure Alarm level (HIGH or LOW), based on the direction of the hardware alarm switch position on the board.

7.1.3

Process Intelligence and Plugged Impulse Line Diagnostics

Introduction

Process Intelligence and Plugged Impulse Line diagnostics provide a means for early detection of abnormal situations in the process environment and process connection. The technology is based on the premise that virtually all dynamic processes have a unique noise or variation signature when operating normally. Changes in these signatures may signal that a significant change will occur or has occurred in the process, process equipment, or transmitter installation. For example, the noise source may be equipment

in the process such as a pump or agitator, the natural variation in the DP value caused by turbulent flow, or a combination of both.

The sensing of the unique signature begins with the combination of the 3051S with Advanced HART Diagnostic Suite and software resident in the diagnostic electronics to compute statistical parameters that characterize and quantify the noise or variation. These statistical parameters are the mean, standard deviation, and coefficient of variation (ratio of standard deviation to mean) of the input pressure. Filtering capability is provided to separate slow changes in the process due to setpoint changes from the process noise or variation of interest. [Figure 7-2](#) shows an example of how the standard deviation value is affected by changes in noise level while the mean or average value remains constant. [Figure 7-3](#) shows an example of how the Coefficient of Variation is affected by changes in the standard deviation and mean.

The calculation of the statistical parameters within the device is accomplished on a parallel software path used to filter and compute the primary output signal (such as the 4–20 mA output). The primary output is not affected in any way by this additional capability.

Figure 7-2: Changes in Process Noise or Variability and Effect on Statistical Parameters

Standard Deviation increases or decreases with changing noise level.

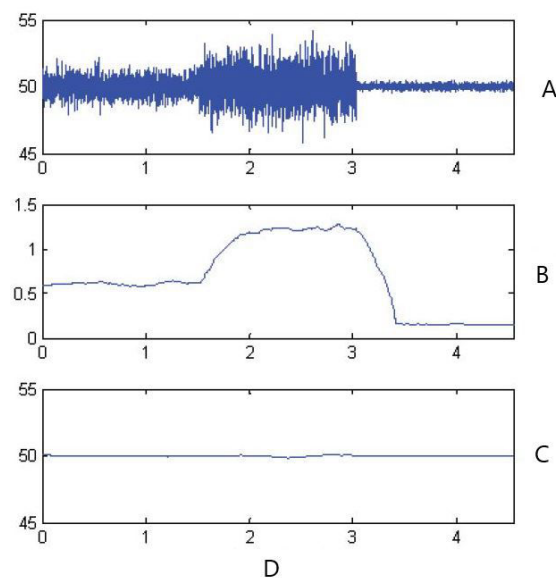

- A. Process noise
- B. Standard deviation
- C. Mean
- D. Time (minutes)

Figure 7-3: CV is the Ratio of Standard Deviation to Mean

CV is stable if Mean is proportional to Standard Deviation.

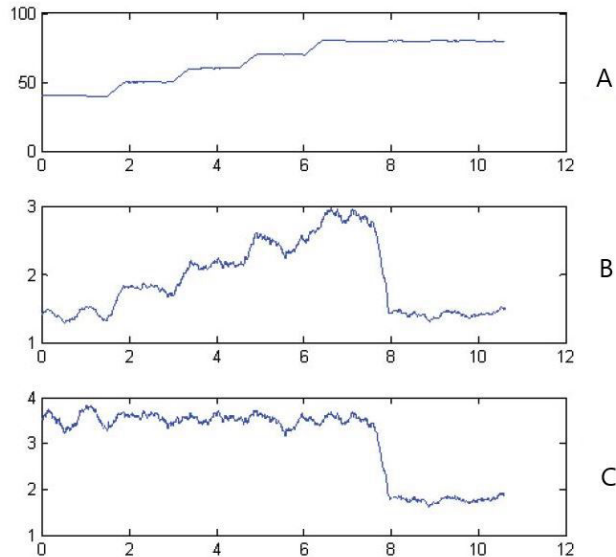

- A. Mean
- B. Standard deviation
- C. Coefficient of variation

This statistical information can be provided to the user in two ways. First, the statistical parameters can be made available to the host system directly via HART communication protocol or HART to other protocol converters. Once available, the system can make use of these statistical parameters to indicate or detect a change in process conditions. In the simplest example, the statistical values may be stored in a data historian. If a process upset or equipment problem occurs, these values can be examined to determine if changes in the values foreshadowed or indicated the process upset. The statistical values can then be made available to the operator directly, or made available to alarm or alert software.

The second way is with software embedded in the 3051S with Advanced HART Diagnostic Suite. The 3051S with Advanced HART Diagnostic Suite uses Process Intelligence or Plugged Impulse Line diagnostics to baseline the process noise or signature via a learning process. Once the learning process is completed, the user can set thresholds for any of the statistical parameters. The device itself can then detect significant changes in the noise or variation, and communicate an alarm via the 4–20 mA output and/or alert via HART Protocol.

Typical applications for the Process Intelligence diagnostic include detecting abnormal process conditions, such as:

- Furnace flame instability
- Pump cavitation
- Distillation column flooding
- Fluid composition change
- Entrained air
- Agitation loss

Typical applications for the Plugged Impulse Line diagnostic include detecting abnormal process connection conditions, such as:

- Plugged impulse lines
- Process leaks
- Coated or plugged Rosemount Annubar

In the following sections, all references to Process Intelligence also apply to the Plugged Impulse Line diagnostic.

Overview

A block diagram of the Process Intelligence and Plugged Impulse Line diagnostics diagnostic is shown in [Figure 7-4](#). The pressure process variable is input to a statistical calculations module where basic high pass filtering is performed on the pressure signal. The mean (or average) is calculated on the unfiltered pressure signal, the standard deviation calculated from the filtered pressure signal. These statistical values are available via HART and handheld communication devices like the Field Communicator or asset management software like Emerson's AMS Device Manager.

The values can also be assigned as secondary variables from the device for 4–20 mA communication to the user through other devices like the 333 HART Tri-Loop or wirelessly through the Emerson Wireless 775 THUM Adapter.

Figure 7-4: Statistical Processing Technology Resident in Transmitter

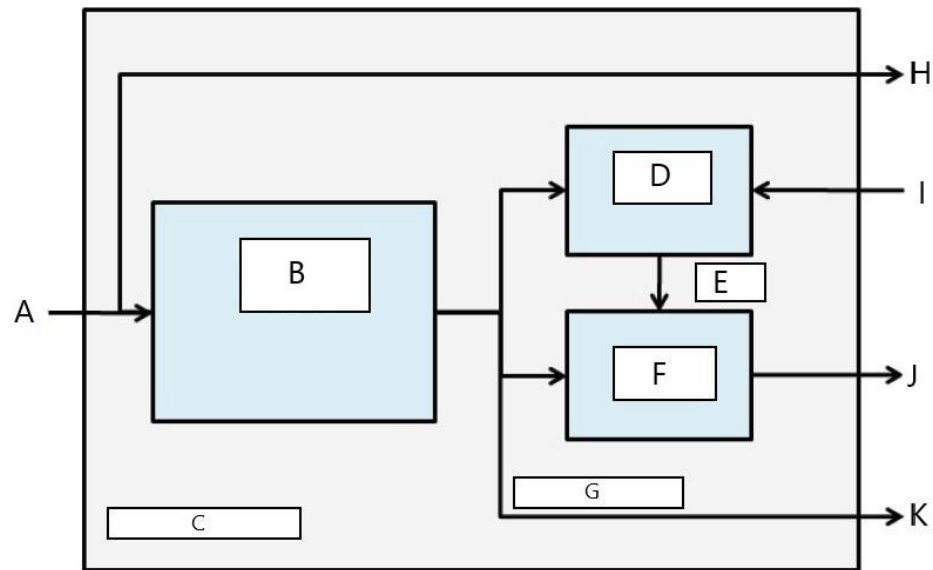

- A. Process variable
- B. Statistical calculations module
- C. Resident in transmitter
- D. Learning module
- E. Baseline values
- F. Decision module
- G. Statistical parameters
- H. Standard outputs (4-20 mA/HART)
- I. Control inputs
- J. HART alert/4-20 mA alarm
- K. Outputs

Process Intelligence and Plugged Impulse Line diagnostics also contains a learning module that establishes the baseline values for the process. Baseline values are established under user control at conditions considered normal for the process and installation. These baseline values are made available to a decision module that compares the baseline values to the most current statistical values. Based on sensitivity settings and actions selected by the user via the control input, the diagnostic generates alarms, alerts, or takes other actions when a significant change is detected in either value.

Figure 7-5: Simplified Process Intelligence and Plugged Impulse Line Diagnostics Flowchart

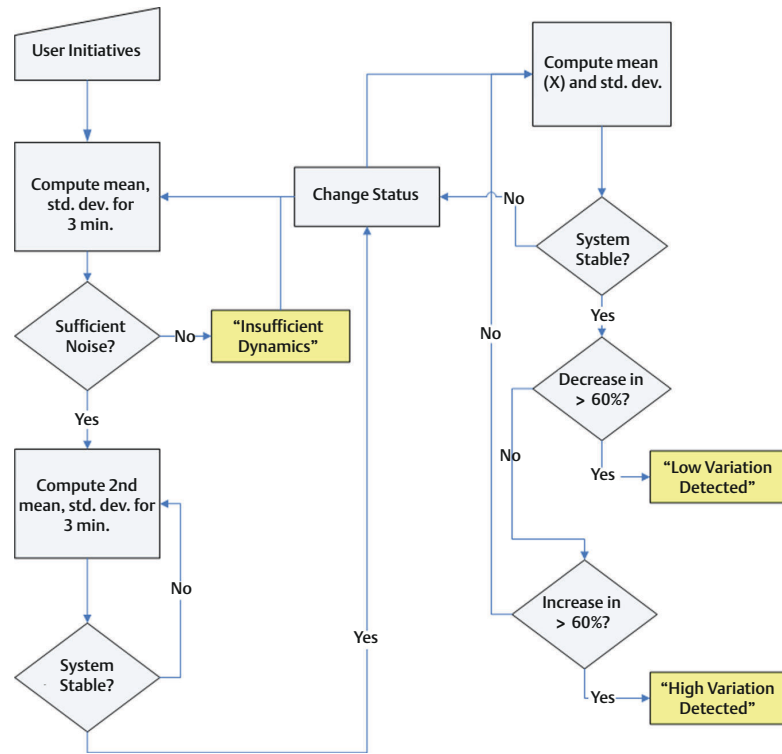

Further detail of the operation of the Process Intelligence and Plugged Impulse Line diagnostics is shown in Figure 7-5. This is a simplified version showing operation using the default values. While these diagnostics continuously calculate the mean, standard deviation, and coefficient of variation values, the learning and decision modules are only evaluated when the diagnostic algorithm is active. Once enabled, the Process Intelligence or Plugged Impulse Line diagnostic enters the learning/verification mode and the status will be *Learning*. The baseline statistical values are calculated over a period of time controlled by the user (Learning/Monitoring Period; default is three minutes).

A check is performed to ensure that the process has a sufficiently high noise or variability level (above the low level of internal noise inherent in the transmitter itself). If the level is too low, the diagnostic will continue to calculate baseline values until the criteria is satisfied (or turned off). A second set of values is calculated and compared to the original set to verify that the measured process is stable and repeatable. During this period, the status will change to *Verifying*. If the process is stable, the diagnostic will use the last set of values as baseline values and change to *Monitoring* status. If the process is unstable, the diagnostic will continue to verify until stability is achieved. The stability criteria are also user defined.

In the *Monitoring* mode, statistical values of mean, standard deviation, and coefficient of variation are continuously calculated, with new values available every second. When using mean and standard deviation as the statistical variables, the mean value is compared to the baseline mean value. If the mean has changed by a significant amount, the diagnostic can automatically return to the *Learning* mode. The diagnostic does this because a significant change in mean is likely due to a change in process operation and can result in a significant change in noise level (standard deviation) as well. If the mean has not changed, the standard deviation value is compared to the baseline value. If the standard deviation

has changed significantly and exceeds configured sensitivity thresholds, this may indicate a change has occurred in the process, equipment, or transmitter installation and a HART alert or analog alarm is generated.

For DP flow applications where the mean pressure is likely to change due to changing process operation, the recommended statistical variable for Process Intelligence or the Plugged Impulse Line diagnostic is the coefficient of variation. Since the coefficient of variation is the ratio of standard deviation to mean, it represents normalized process noise values even when the mean is changing. If the coefficient of variation changes significantly relative to the baseline and exceeds sensitivity thresholds, the transmitter can generate a HART alert or analog alarm.

Note

Process Intelligence and Plugged Impulse Line diagnostic capability in the 3051S Pressure Transmitter with Advanced HART Diagnostics calculates and detects significant changes in statistical parameters derived from the input pressure signal. These statistical parameters relate to the variability of the noise signals present in the pressure signal. It is difficult to predict specifically which noise sources may be present in a given pressure measurement application, the specific influence of those noise sources on the statistical parameters, and the expected changes in the noise sources at any time. Therefore, Emerson cannot absolutely warrant or guarantee that the Process Intelligence or Plugged Impulse Line diagnostics will accurately detect each specific condition under all circumstances.

Assigning statistical values to outputs

HART 5 with Diagnostics Fast Keys	2, 2, 5, 1
HART 7 Fast Keys	2, 2, 5, 1

The statistical values of mean, standard deviation, and Coefficient of Variation can be made available to other systems or data historians via HART Communication. WirelessHART®, such as the Emerson Wireless 775 THUM Adapter can also be used to obtain additional variables. Devices that convert HART variables to analog 4–20 mA outputs, such as the 333 Tri-Loop can also be used.

Statistical values can be assigned to be secondary (SV), tertiary (TV), or quaternary (QV) variables. This is accomplished through Variable Mapping. See [Figure 7-6](#).

Figure 7-6: Selection of Statistical Values as Secondary Variables

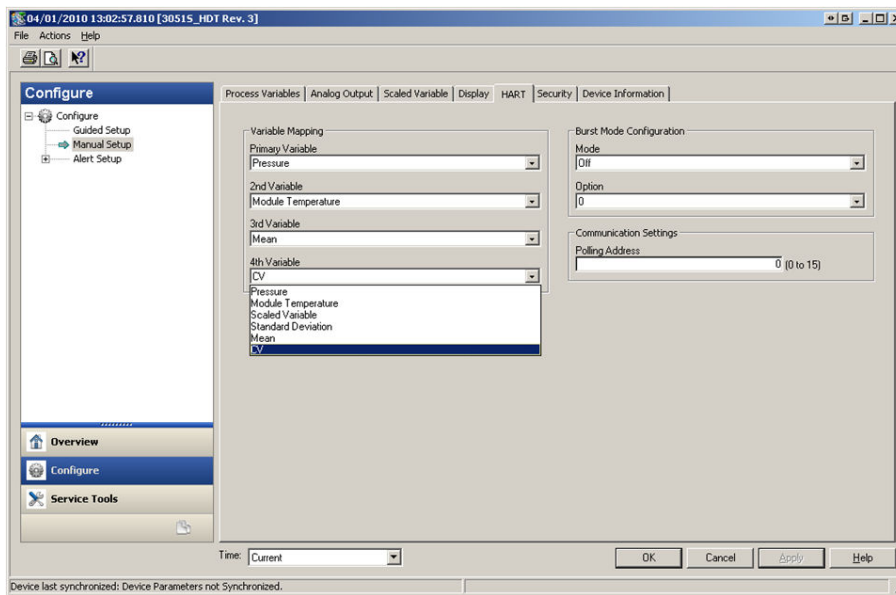

Process Intelligence and Plugged Impulse Line Diagnostics configuration

HART 5 with Diagnostics Fast Keys	2, 1, 2, 1
HART 7 Fast Keys	2, 1, 2, 1

For inexperienced users, Emerson recommends guided setup. Guided setup walks the user through settings that configure the Process Intelligence or Plugged Impulse Line diagnostic for most common usage and applications. The method for both diagnostics is the same. In the asset management interface, the Process Intelligence and Plugged Impulse Line diagnostics are referred to as **Statistical Process Monitoring**.

Figure 7-7: Guided Setup Menu

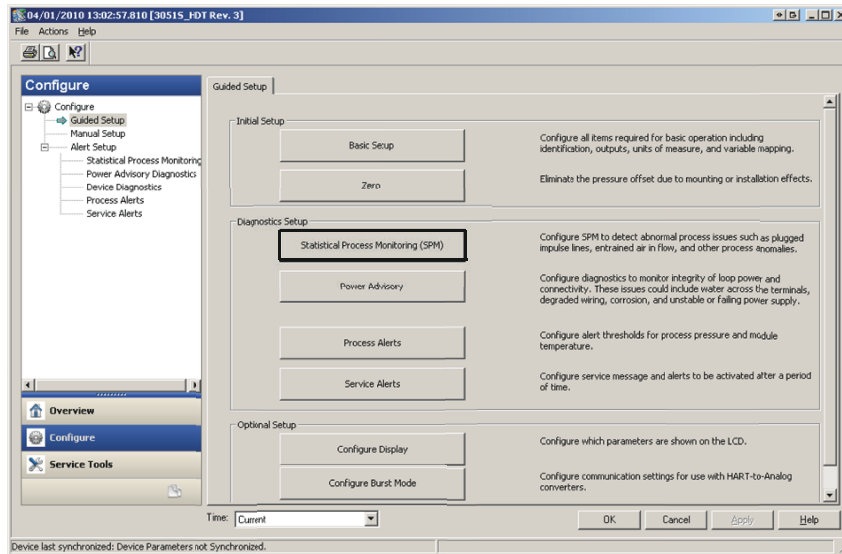

The rest of the configuration section explains the parameters for manual configuration of the Process Intelligence or Plugged Impulse Line diagnostics.

Figure 7-8: SPM status screen

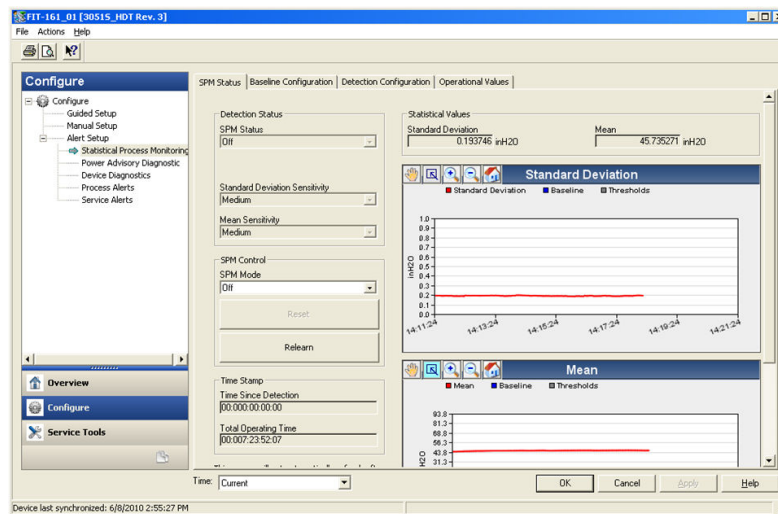

The SPM status screen shows overview information for the diagnostic.

The process for operation of the Process Intelligence and Plugged Impulse Line diagnostics is:

- Configure the diagnostic using Baseline Configuration and Detection Configuration screens.
- Turn on the diagnostic from the SPM Status screen.

The configuration process starts with Baseline Configuration, [Figure 7-9](#). The configurable fields are:

SPM variable

This is the statistical variable to be used for Process Intelligence and Plugged Impulse Line diagnostic detection.

- Std Dev and Mean (default)** Standard deviation and mean of the process are calculated. Users can set independent sensitivity thresholds for both statistical variables.
- Coefficient of Variation (CV)** CV is calculated from the ratio of standard deviation to mean and is better suited for DP flow applications where the mean pressure is likely to change due to changing process operation. CV puts standard deviation in context of the mean and is represented as a % value.

Figure 7-9: Baseline Configuration Screen

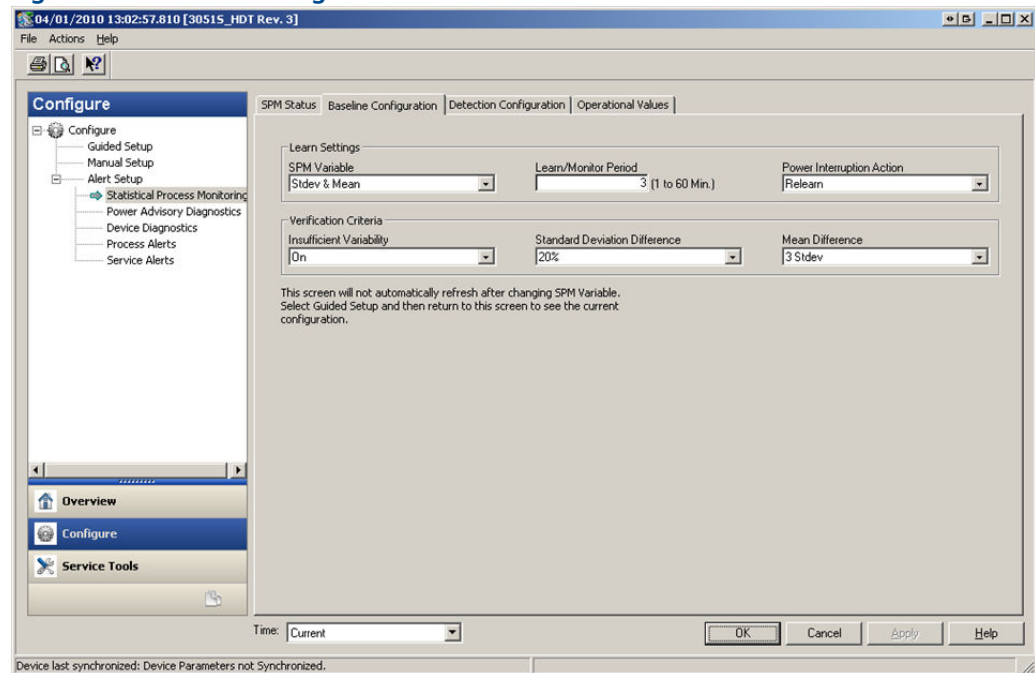

Learn/Monitor Period

This is the learning and monitoring time period that the Process Intelligence and Plugged Impulse Line diagnostics use to sample the pressure signal. The mean and standard deviation or Coefficient of Variation values determined during the learning period will become the Baseline values. Decreasing this period can speed up the set up time and is recommended for stable process operations. Increasing this value will give a better baseline value for noisier processes. If false trips for *High Variation Detected* are occurring due to rapid changes in the process and statistical value, increasing the learning period is recommended. The Learn/Monitor Period is always set in minutes. The default value is three minutes and the valid range is one to 60 minutes.

Figure 7-10 illustrates the effect of Learn/Monitor Period on the statistical calculations. Notice how a shorter sampling window of three minutes captures more variation (meaning the plot looks noisier) in the trend. With the longer sampling window of 10 minutes, the trend looks smoother, because the diagnostic algorithm uses process data sampled over a longer period of time.

Figure 7-10: Effect of Learn/Monitor Period on Statistical Values

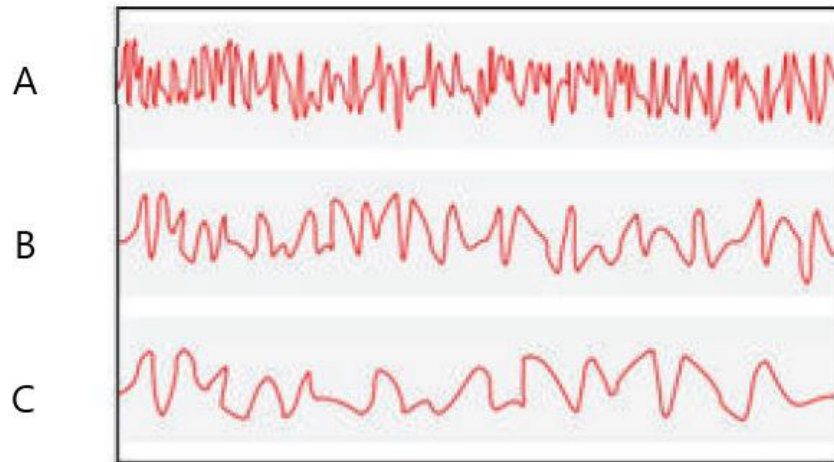

- A. Three minutes
- B. Five minutes
- C. Ten minutes

Power interruption action

This is used to direct what the diagnostic should do in the case of a power interruption or if the diagnostic is manually disabled and then enabled. The options are:

- Monitor (default)** When the Process Intelligence or Plugged Impulse Line diagnostic restarts, the diagnostic returns to the Monitoring mode immediately and uses the baseline values computed before the interruption.
- Relearn** When the Process Intelligence or Plugged Impulse Line diagnostic restarts, the diagnostic enters the Learning mode and will recalculate new baseline values.

Low pressure cut-off

This is the minimum pressure required to operate the diagnostic with Coefficient of Variation selected as the statistical variable. The Coefficient of Variation is a ratio of standard deviation to mean and is defined for non-zero mean values. When the mean value is near zero, the Coefficient of Variation is sensitive to small changes in the mean, limiting its usefulness. Default value is one percent of upper sensor limit.

Insufficient Variability

The Process Intelligence and Plugged Impulse Line diagnostics use process noise to baseline the process and detect abnormal situations. Typically the Insufficient Variability check is on to ensure there is sufficient noise for proper operation. In a quiet application with very minimal process noise, this setting can be turned off. The default setting is ON.

Parameter	Definition
On (default)	Perform insufficient variation check
Off	Do not perform insufficient variation check

Standard Deviation Difference, Mean Difference

If these difference values are exceeded during the Verification mode, the Process Intelligence or Plugged Impulse Line diagnostic will not start **Monitoring** mode and will continue verifying the baseline.

If the diagnostic will not leave the **Verification** mode, these values should be increased.

If the diagnostic still remains in the **Verification** mode with the highest level, the Learn/Monitor period should be increased.

Table 7-1: Standard Deviation Verification Criteria

Parameter	Definition
None	Do not perform any verification checks for standard deviation.
10%	If the difference between baseline standard deviation value and the verification value exceeds 10%, diagnostic will stay in Verification mode.
20% (default)	If the difference between baseline standard deviation value and the verification value exceeds 20%, diagnostic will stay in Verification mode.
30%	If the difference between baseline standard deviation value and the verification value exceeds 30%, diagnostic will stay in Verification mode.

Table 7-2: Mean Verification Criteria

Parameter	Definition
None	Do not perform any verification checks for mean.
3 Stdev (default)	If the difference between baseline mean value and the verification value exceeds 3 standard deviations, diagnostic will stay in Verification mode.
6 Stdev	If the difference between baseline mean value and the verification value exceeds 6 standard deviations, diagnostic will stay in Verification mode.
2%	If the difference between baseline mean value and the verification value exceeds 2%, diagnostic will stay in Verification mode.

The Detection Configuration screen ([Figure 7-11](#) and [Figure 7-12](#)) allows for configuration of sensitivity threshold values for tripping the diagnostic and how to receive the HART alert or analog alarm.

Figure 7-11: Detection Configuration Screen for Standard Deviation Change and Mean Change

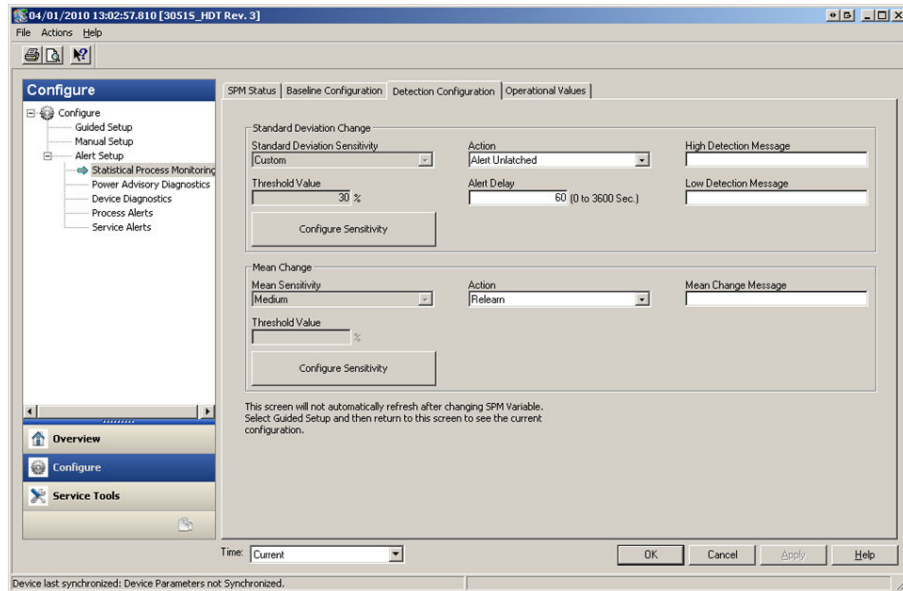
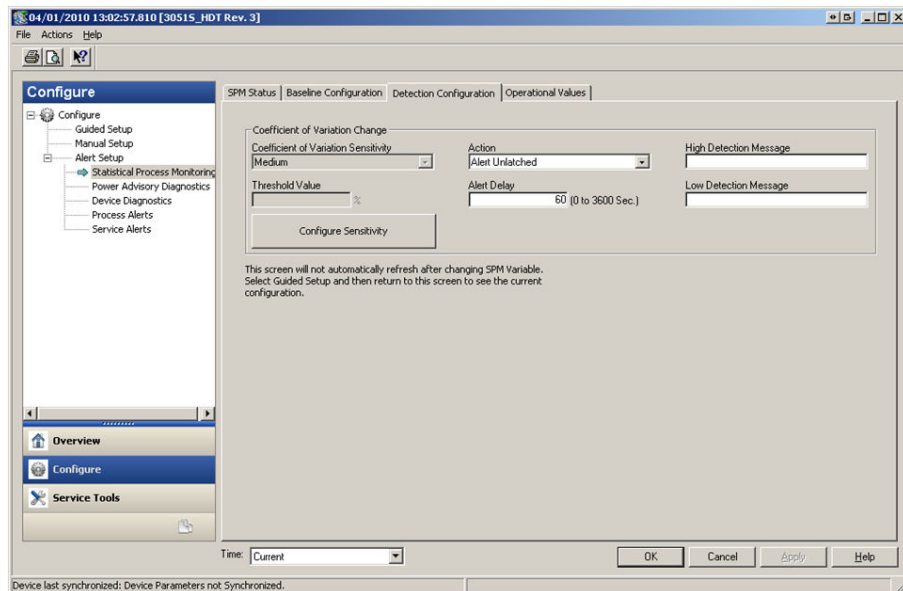

Figure 7-12: Detection Configuration Screen for Coefficient of Variation Change



Standard Deviation Sensitivity, Mean Sensitivity

Shows the current sensitivity level for detecting changes in standard deviation or mean. Users can choose from preset values of High, Medium, and Low. Custom sensitivity levels can also be configured.

Coefficient of Variation sensitivity

Shows the current sensitivity level for detecting changes in the Coefficient of Variation. Users can choose from preset values of High, Medium, and Low. Custom sensitivity levels can also be configured.

Figure 7-13 illustrates the differences in preset sensitivity limits of High, Medium, and Low. The preset High sensitivity setting (such as 20 percent) will cause the Process Intelligence or Plugged Impulse Line diagnostic to be more sensitive to changes in the process profile. The preset Low sensitivity setting (such as 80 percent) will cause the SPM diagnostic to be less sensitive as a much greater change in the process profile is needed to trip the alert.

Figure 7-13: Preset Sensitivity Levels

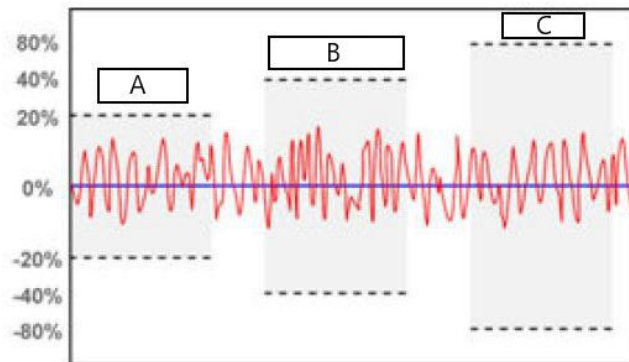

- A. High
- B. Medium
- C. Low

Threshold value

If sensitivity is custom, this field will display the custom sensitivity setting as percent change from the baseline value.

Configure sensitivity

This button launches a window for entering sensitivity settings.

Table 7-3: Standard Deviation sensitivity choices

Parameter	Definition
Low	80% change from baseline value will trip the diagnostic
Medium (default)	60% change from baseline value will trip the diagnostic
High	40% change from baseline value will trip the diagnostic
Custom	Adjustable from 1 to 10,000%

Table 7-4: Mean sensitivity choices

Parameter	DP	Gauge Pressure/Absolute Pressure (GP/AP)
Low	Change of 40% from baseline value or 4% of span from baseline value, whichever is greater, will trip the diagnostic	Change of 20% of span from baseline value will trip the diagnostic

Table 7-4: Mean sensitivity choices (continued)

Parameter	DP	Gauge Pressure/Absolute Pressure (GP/AP)
Medium (default)	Change of 20% from baseline value or 2% of span from baseline value, whichever is greater, will trip the diagnostic	Change of 10% of span from baseline value will trip the diagnostic
High	Change of 10% from baseline value or 1% of span from baseline value, whichever is greater, will trip the diagnostic	Change of 5% of span from baseline value will trip the diagnostic
Custom	Adjustable from 1 to 10,000% of value	Adjustable from 1 to 10,000% of span

Table 7-5: Coefficient of Variation sensitivity choices

Parameter	Definition
Low	80% change from baseline value will trip the diagnostic
Medium (default)	40% change from baseline value will trip the diagnostic
High	20% change from baseline value will trip the diagnostic
Custom	Adjustable from 1 to 10,000%

Alert delay

This value specifies the amount of delay from when the transmitter detects a deviation from the sensitivity threshold to generating an alert or alarm. The default value is 60 seconds, and valid range is zero to 3,600 seconds. Increasing the alert delay helps to avoid false detections resulting from the standard deviation or coefficient of variation exceeding the threshold only momentarily.

High detection message

Customizable message field related to standard deviation/Coefficient of Variation crossing the upper sensitivity threshold value. This message can be used to describe the abnormal process condition or provide additional details for troubleshooting. Message will appear along with the High Variation or High CV Detected alert. Character limit is 32 including spaces.

Low detection message

Customizable message field related to Standard Deviation/Coefficient of Variation crossing the lower sensitivity threshold value. This message can be used to describe the abnormal process condition or provide additional details for troubleshooting. Message will appear along with the Low Variation or Low CV Detected alert. Character limit is 32 including spaces.

Mean change message

Customizable message field related to mean value crossing either the upper or lower sensitivity threshold value. This message can be used to describe the abnormal process condition or provide additional details for troubleshooting. Message will appear along with the Mean Change Detected alert. Character limit is 32, including spaces.

Process Intelligence Diagnostic Operation

HART 5 with Diagnostics Fast Keys	2, 3, 1, 1, 2
-----------------------------------	---------------

HART 7 Fast Keys	2, 3, 1, 1, 2
------------------	---------------

Figure 7-14: Process Intelligence Diagnostic can be Activated from the SPM Status Screen

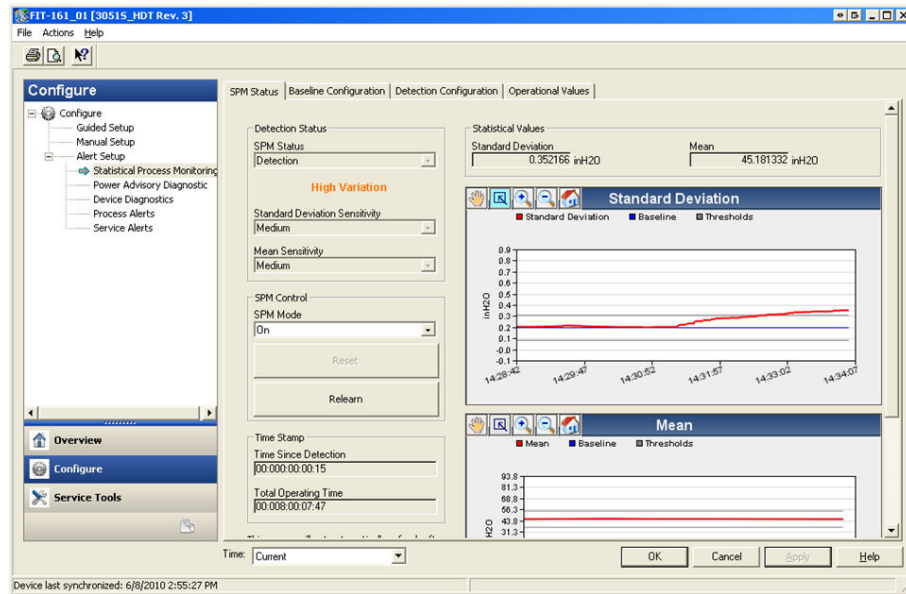

Turning on the Process Intelligence or Plugged Impulse Line diagnostic

The Process Intelligence and Plugged Impulse Line diagnostics are enabled by selecting **On** for **SPM Mode**, shown on Figure 7-14. Upon enabling, the diagnostic will automatically begin **Learning** with the following exception: if valid baseline values have been previously established and **Monitor** has been selected as the option for Power Interruption on the Baseline Configuration screen, then the diagnostic will bypass **Learning** and begin **Monitoring** immediately. The diagnostic status will stay in the **Learning** mode for the Learning Period specified on the Baseline Configuration screen. After the learning period is complete, the mode will change to **Verifying**, and a blue line will appear on the charts indicating the learned baseline value. Upon completion of the **Verify** mode, the diagnostic will use the parameters selected on the Verification Criteria section to validate the baseline value. After the Verifying period, the mode will switch to **Monitoring** and gray lines that indicate the sensitivity setting will appear on the charts.

Reset

If the diagnostic trip action is set to **Alert Latched**, clicking on **Reset** will clear the alert when process conditions are back to normal or baseline.

Relearn

Selecting this button will cause the Process Intelligence or Plugged Impulse Line diagnostic to relearn the process condition and establish a new baseline. Manually performing a relearn is recommended if the process profile has been intentionally changed to a new set point.

Figure 7-15: Operational Values Screen

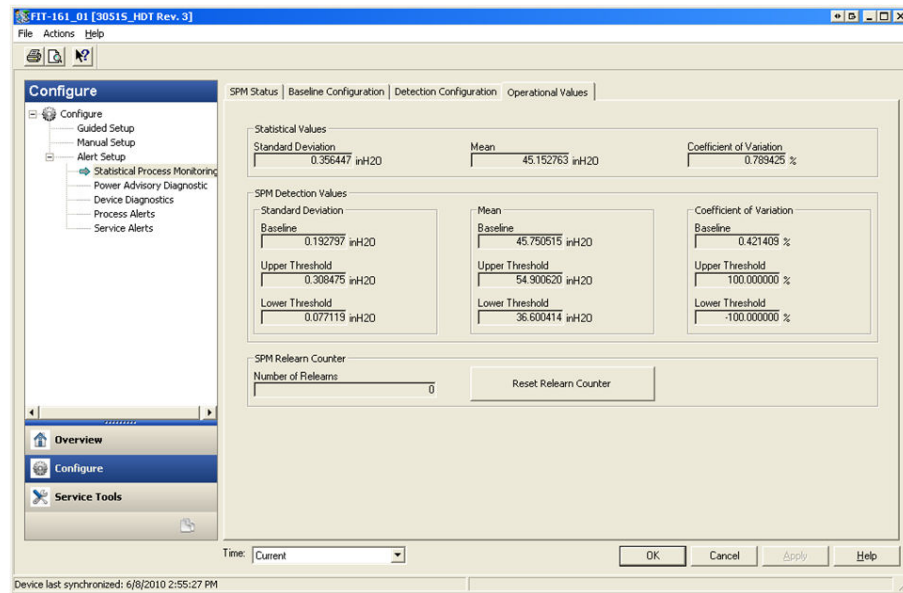

The Operational Values screen contains the parameter values used in the Process Intelligence and Plugged Impulse Line diagnostics.

- Standard Deviation** This is the current value of standard deviation. This value is continuously calculated and can be provided as a secondary variable.
- Mean** This is the current value of mean. This value is continuously calculated and can be provided as a secondary variable.
- Coefficient of Variation** This is the current value for coefficient of variation. The coefficient of variation is derived from the ratio of standard deviation to mean. This value is continuously calculated and can be provided as a secondary variable.
- Number of Relearns** This is the number of times the diagnostic algorithm relearn has been initiated by the user or via automatic relearn.

Detection

If the Process Intelligence or Plugged Impulse Line diagnostic detects a standard deviation, mean, or coefficient of variation change outside the threshold values, the SPM Status box will indicate *Detection*, followed by the type of detection.

The LCD display will also indicate the diagnostic condition. The *Time Since Detection* clock in the Time Stamp box will start incrementing until the statistical value is returned to normal. If the diagnostic alert is latched, the *Time Since Detection* clock will continue to increment until the alert is reset or the diagnostic is turned off.

Interpreting results

The Process Intelligence and Plugged Impulse Line diagnostics can be used to detect installation problems and changes or problems in process and equipment. However, as the diagnostic is based on detecting changes in process noise or variability, there are many possible reasons or sources for the change in values and detection. Following are some possible causes and solutions if a diagnostic event is detected:

Table 7-6: Possible Causes of Process Intelligence or Plugged Impulse Line Diagnostic Events

Detection type	LCD display	Potential cause	Corrective action
High Variation Detected/High CV Detected	HIGH VARIA/ HIGH CV	Plugged impulse line (DP only)	Follow facility procedure to check for and clear plugged impulse lines. Both lines must be checked as the SPM diagnostic cannot determine if the plug is on the high or low side. Conditions that lead to plugging on one side may lead to an eventual plug on the other side.
		Aeration or aeration increase (liquid flow)	<ol style="list-style-type: none"> 1. If aeration is undesired, take necessary steps to eliminate aeration. 2. If the measurement is DP flow and aeration is not desired, move primary element to another location in the process piping to ensure it remains full (no air) under all conditions.
		Liquid present or amount of liquid increased (gas or steam flow)	<ul style="list-style-type: none"> • If liquid is undesired, take necessary steps to eliminate liquid in gas or steam flow. • If some liquid is normal, and error correction in the gas flow measurement is being done (such as an over-reading in wet natural gas measurements), you may need to determine the volume fraction of the liquid (using a test separator) and a new error correction factor for the gas flow measurement.
		Solids present or solids level increased	If solids are undesired, take necessary steps to eliminate.
		Control loop problem (valve stiction, controller issue, etc.)	Review control valve or loop for control problems.
		Process or equipment change or problem has resulted in an increase in the pressure noise level	Check process equipment.

Table 7-6: Possible Causes of Process Intelligence or Plugged Impulse Line Diagnostic Events (continued)

Detection type	LCD display	Potential cause	Corrective action
High Variation Detected	HIGH VARIA	Rapid change of process variable mean value	<p>Rapid changes in the process variable can result in indication of high variation.</p> <ul style="list-style-type: none"> If undesired, increase Alert Delay value (default is 60 seconds). Increase the Learn/Monitor period (default is 3 minutes).
Low Variation Detected/Low CV Detected	LOW VARIA/ LOW CV	Plugged impulse line (DP/AP/GP)	Follow facility procedure to check for and clear plugged impulse lines. For DP device installations, both lines must be checked as the Plugged Impulse Line diagnostic cannot determine if the plug is on the high or low side; conditions that lead to plugging on one side may lead to an eventual plug on the other side.
		Aeration decrease	<ul style="list-style-type: none"> If decrease is normal, reset and relearn.
		Decrease of liquid content in gas or steam flow	<ul style="list-style-type: none"> If not, check process and equipment for change in operating conditions.
		Decrease in solids content	<ul style="list-style-type: none"> If decrease is normal, reset and relearn. If not, check process and equipment for change in operating conditions. For example, a stuck control valve can reduce variability.
Reduction in variability in process	<ul style="list-style-type: none"> If decrease is normal, reset and relearn. If not, check process and equipment for change in operating conditions. For example, a stuck control valve can reduce variability. 		
Mean Change Detected	MEAN CHANGE	Significant process setpoint change	<ul style="list-style-type: none"> If change is normal, reset and relearn. Consider changing mean change detection to automatically relearn. If change is not expected, check process and equipment for change in operating conditions.

Note

Emerson cannot absolutely warrant or guarantee that Process Intelligence or Plugged Impulse Line diagnostics will accurately detect each specific abnormal condition under all circumstances. Standard maintenance procedures and safety precautions should not be ignored because the Process Intelligence or Plugged Impulse Line diagnostic is enabled.

Troubleshooting the Process Intelligence and Plugged Impulse Line diagnostics

Users are encouraged to pre-test the Process Intelligence and Plugged Impulse Line diagnostics if possible.

For example, if the diagnostic is to be used to detect plugged impulse lines, and if root valves are present in the installation, the user should set up the diagnostic as described earlier, and then alternately close the high and the low side root valve to simulate a plugged impulse line. Using the SPM Status screen, the user can then note the changes to the standard deviation or Coefficient of Variation under the closed conditions and adjust the sensitivity values as needed.

Table 7-7: Possible Process Intelligence and Plugged Impulse Line diagnostic Issues and Resolutions

Process Intelligence diagnostic issue	Action
Diagnostic status indicates insufficient variability and will not leave learning or verifying mode	Process has very low noise. Turn off insufficient variability check (Verification Criteria screen). Process Intelligence or Plugged Impulse Line diagnostic will be unable to detect a significant decrease in noise level.
Diagnostic will not leave verifying mode	Process is unstable. Increase learning sensitivity checks (Verification Criteria screen). If this does not correct the issue, increase the learning verification period to match or exceed the cycle time of the instability of the process. If maximum time does not correct the problem, process is not a candidate for Process Intelligence or Plugged Impulse Line diagnostic. Correct stability issue or turn off diagnostic.
Diagnostic does not detect a known condition	With the condition present, but the process operating, go to the SPM Status or Operational Values screen and note the current statistical values and compare to the baseline and threshold values. Adjust the sensitivity threshold values until a trip of the diagnostic occurs.
Diagnostic indicates High Variation Detected when no diagnostic event has occurred	The most likely cause is a fast change in the value of the process variable. Direction of the change is not important. Increase the learning/monitoring period to better filter out increases in standard deviation.

7.1.4 Loop Integrity

Introduction

The Loop Integrity diagnostic provides a means to detect issues that may jeopardize the integrity of the electrical loop. Some examples are: water entering the wiring compartment and makes contact with the terminals, an unstable power supply nearing end of life, or heavy corrosion on the terminals.

This technology is based on the premise that once a transmitter is installed and powered up, the electrical loop has a baseline characteristic that reflects the proper installation. If the transmitter terminal voltage deviates from the baseline and outside the user configured threshold, the 3051S with Advanced HART Diagnostics can generate a HART alert or analog alarm.

To make use of this diagnostic, the user must first create a baseline characteristic for the electrical loop after the transmitter has been installed. The loop is automatically characterized with the push of a button. This creates a linear relationship for expected terminal Voltage values along the operating region from 4–20 mA. See [Figure 7-16](#).

Figure 7-16: Baseline Operating Region

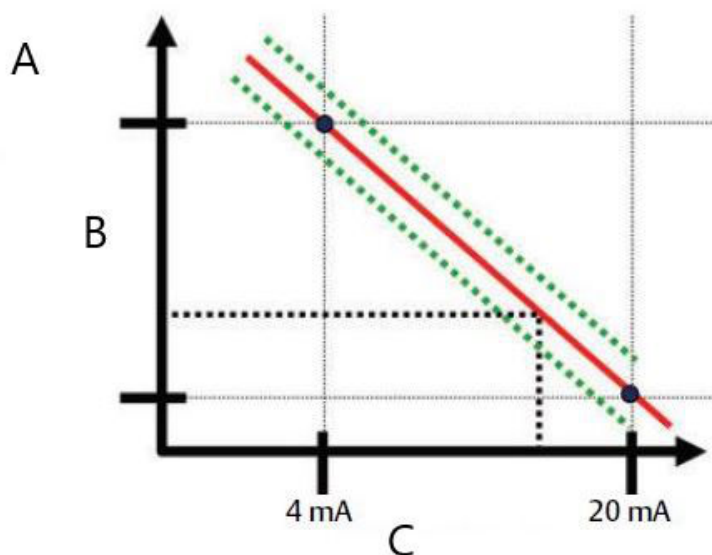

- A. Terminal voltage
- B. Volts
- C. Output current

Overview

The transmitter is shipped with Loop Integrity off as default and without any loop characterization performed. Once the transmitter is installed and powered up, loop characterization must be performed for the Loop Integrity diagnostic to function.

When the user initiates a loop characterization, the transmitter will check to see if the loop has sufficient power for proper operation. Then the transmitter will drive the analog output to both 4 and 20 mA to establish a baseline and determine the maximum allowable terminal voltage deviation. Once this is complete, the user enters a sensitivity threshold called **Terminal Voltage Deviation Limit** and a check is in place to make sure this threshold value is valid.

Once the loop has been characterized and Terminal Voltage Deviation Limit is set, Loop Integrity actively monitors the electrical loop for deviations from the baseline. If the terminal voltage has changed relative to the expected baseline, exceeding the configured Terminal Voltage Deviation Limit, the transmitter can generate an alert or alarm.

Note

The Loop Integrity diagnostic in the 3051S Pressure Transmitter with Advanced HART Diagnostics monitors and detects changes in the terminal Voltage from expected values to detect common failures. It is not possible to predict and detect all types of electrical failures on the 4–20mA output. Therefore, Emerson cannot absolutely warrant or guarantee that the Loop Integrity diagnostic will accurately detect failures under all circumstances.

Configuration

HART 5 with Diagnostics Fast Keys	2, 1, 2, 2
HART 7 Fast Keys	2, 1, 2, 2

For inexperienced users, guided setup is recommended. Guided setup walks the user through settings that configure the Loop Integrity diagnostic for most common usage and applications. In the asset management interface, the Loop Integrity diagnostic is referred to as **Power Advisory**.

Figure 7-17: Guided Setup Menu screen

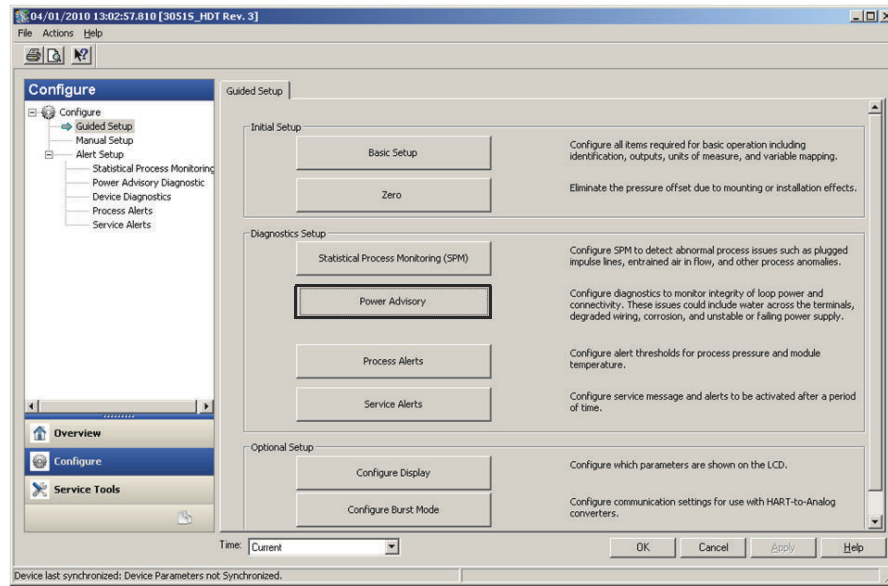

The rest of the configuration section explains the parameters for manual configuration of the Loop Integrity diagnostic.

Figure 7-18: Manual Configuration of Power Advisory Main Screen

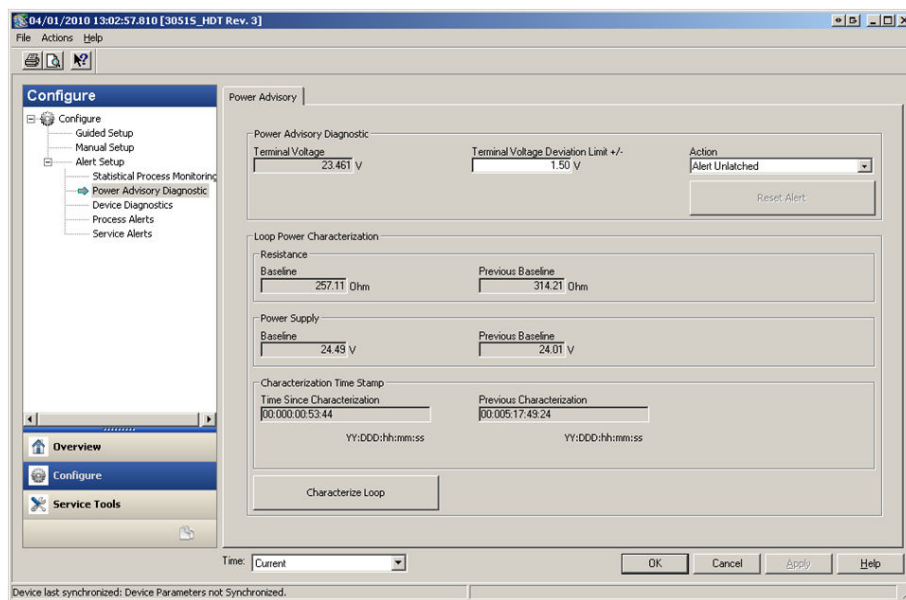

The Power Advisory configuration screen allows users to characterize the loop and configure the Terminal Voltage Deviation Limit and the Action. Two instances of loop

characterization data are recorded and presented on this screen: Baseline and Previous Baseline. Baseline represents values from the most recent loop characterization whereas Previous Baseline represents values recorded prior to the most recent characterization.

Terminal Voltage

This field shows the current terminal Voltage value in Volts. The terminal Voltage is a dynamic value and is directly related to the mA output value.

Terminal Voltage Deviation Limit

The terminal Voltage deviation limit should be set large enough that “expected” voltage changes do not cause false failures. The default value of 1.5 V will accommodate typical deviation of customer power supply voltage and loop tests (amp meters connected across the test diode on the terminal block). This value should be increased if your loop has additional “expected” variation

Figure 7-19: Voltage Deviation Limit

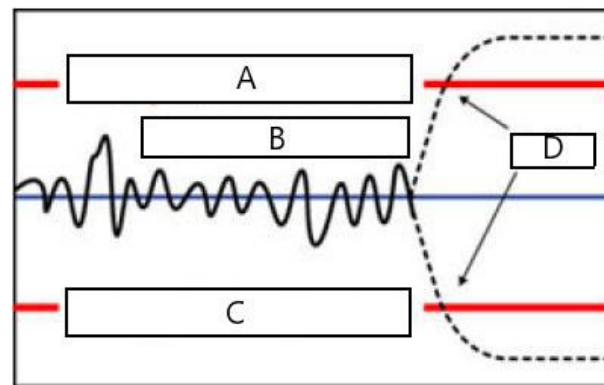

- A. Voltage deviation limit
- B. Terminal voltage
- C. Voltage deviation limit
- D. Alert

Resistance

This value is the calculated resistance of the electrical loop (in Ohms) measured during the Characterize Loop procedure. Changes in the resistance may occur due to changes in the physical condition of the loop installation. Baseline and Previous Baselines can be compared to see how much resistance has changed over time.

Power Supply

This value is the calculated power supply voltage of the electrical loop (in Volts) measured during the Characterize Loop procedure. Changes in this value may occur due to degraded performance of the power supply. Baseline and Previous Baselines can be compared to see how much the power supply has changed over time.

Characterization Time Stamp

This is the time stamp or elapsed time of the loop characterization event. All time values are non-volatile and displayed in the following format: yy:dd:hh:mm:ss (years:days:hours:minutes:seconds).

Characterize Loop

Loop characterization must be initiated when the transmitter is first installed or when electrical loop characteristics have been intentionally altered. Examples include more transmitters being added onto the loop, modified power supply level or loop resistance of the system, changing the terminal block on the transmitter, or adding the Wireless 775 THUM Adapter to the transmitter. Another case of required re-characterization is if the diagnostic electronics are taken out of an existing 3051S Transmitter and placed in a new 3051S installed on a different loop.

Note

The Loop Integrity diagnostic is not recommended for transmitters operating in HART Burst Mode (fixed current mode) or multidrop.

Troubleshooting

Table 7-8: Possible Loop Integrity diagnostic issues and resolutions

Issue	Resolution
Transmitter automatically resets upon annunciation of HIGH alarm.	The loop has been severely degraded and the transmitter does not have enough voltage to generate a HIGH alarm. Transmitter reset will create a low off-scale reading. Repair damaged loop.
Transmitter does not generate LOW alarm value when it should.	The loop has been severely degraded, and the host system is not able to read the proper mA output from the transmitter. This may occur if water floods the terminal compartment and “shorts out” the + to – terminals or the terminals to chassis. This is most likely to occur if the loop resistor is connected to the + side of the power supply. Repair the damaged loop. Consider setting alarm direction to HIGH.
Transmitter does not generate HIGH alarm value.	The loop has been severely degraded, and the host system is not able to read the proper mA output from the transmitter. This may occur if water floods the terminal compartment and “shorts out” the + to – terminals or the terminals to chassis. This is most likely to occur if the loop resistor is connected to the – side of the power supply and is earth grounded. Repair the damaged loop. Consider setting alarm direction to LOW.
Diagnostic does not detect a damaged loop.	Diagnostic will not trip if loop characterization was performed when the loop was already damaged. Repair damaged loop and re-characterize.
Diagnostic is detecting false alarms or alerts.	Re-characterize the loop and compare the baseline with the previous baseline. Resistance changes may indicate poor or intermittent connections. Power supply voltage changes may indicate unstable supply. Test for the presence of AC voltage using an AC DVM or oscilloscope. Adding an amp meter across the test diode will cause voltage changes of up to 1 V. If all conditions look acceptable, increase the terminal Voltage deviation limit.

7.1.5

Diagnostic Log

HART 5 with Diagnostics Fast Keys	3, 4, 2
HART 7 Fast Keys	3, 4, 4

Diagnostic Log Overview

The diagnostic log provides a history of the last ten transmitter alerts and time stamp of when they occurred. This allows the user to reference a sequence of events or alerts to aid the troubleshooting process. The log prioritizes and manages the alerts in a first-in,

first-out manner. This log is stored in the non-volatile internal memory of the Rosemount 3051S Pressure Transmitter with Advanced HART Diagnostics. If power is removed from the transmitter, the log remains intact and can be viewed again when powered up.

Figure 7-20: Diagnostic Log

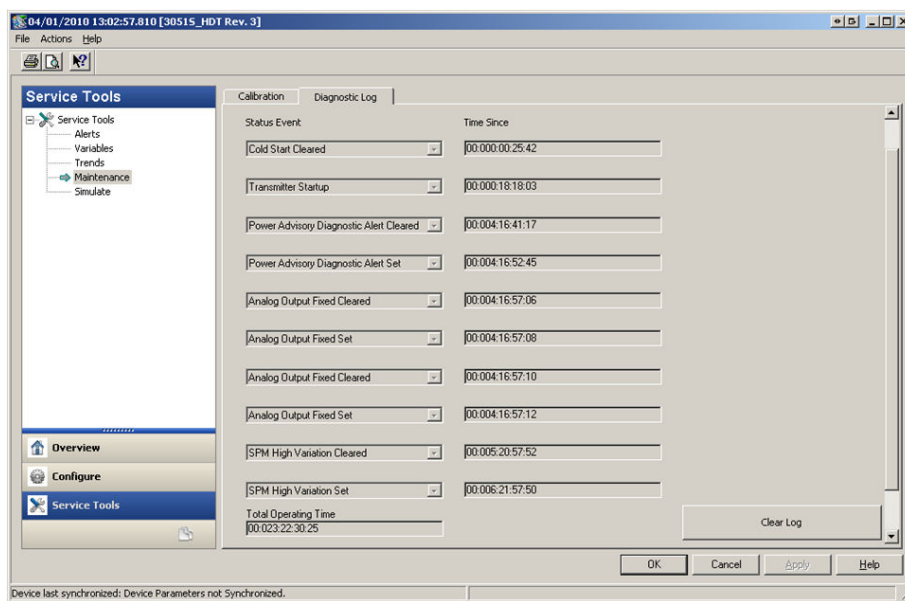

Figure 7-20 shows the Diagnostic Log screen where a set of ten events and time stamp can be seen.

Status event

This is the name of the event that was recorded in the transmitter. Table 7-9 shows a list of possible status events that can be recorded.

Table 7-9: Possible status events for Diagnostic Log

Alert/status	Criticality
CPU Error Set, Cleared	Failed
Electronics Failure Set, Cleared	Failed
Field Device Malfunction Set, Cleared	Failed
HW/SW Incompatibility Set, Cleared	Failed
mA Output Diagnostic Alert Set, Cleared	Failed
NV Error Set, Cleared	Failed
Pressure Not Updating Set, Cleared	Failed
RAM Error Set, Cleared	Failed
ROM Error Set, Cleared	Failed
Sensor Failure Set, Cleared	Failed
Stack Overflow Set, Cleared	Failed
SW Flow Control Error Set, Cleared	Failed
Transmitter Power Consumption Alert Set, Cleared	Failed

Table 7-9: Possible status events for Diagnostic Log (continued)

Alert/status	Criticality
Analog Output Fixed Set, Cleared	Maintenance
Analog Output Saturated Set, Cleared	Maintenance
Power Advisory Diagnostic Alert Set, Cleared	Maintenance
Pressure Out of Limits Set, Cleared	Maintenance
Sensor Trim Mode Set, Cleared	Maintenance
Temperature Compensation Error Set, Cleared	Maintenance
Temperature Not Updating Set, Cleared	Maintenance
Cold Start Cleared	Advisory
High CV Change Set, Cleared	Advisory
Key Error Set, Cleared	Advisory
LCD Update Error Set, Cleared	Advisory
Low CV Change Set, Cleared	Advisory
New Sensor Set, Cleared	Advisory
Pressure Alert Set, Cleared	Advisory
Scaled Variable Low Flow Set, Cleared	Advisory
Service Alert Set, Cleared	Advisory
SPM High Variation Set, Cleared	Advisory
SPM Low Pressure Cutoff Set, Cleared	Advisory
SPM Low Variation Set, Cleared	Advisory
SPM Mean Change Detected Set, Cleared	Advisory
Stuck Key Set, Cleared	Advisory
Temperature Alert Set, Cleared	Advisory
Temperature Out of Limits Set, Cleared	Advisory
Transmitter Startup	Advisory

Note

Emerson recommends replacing transmitters showing **Failed** status.

Time since

This is the time stamp or elapsed time of the status event. All time values are non-volatile and displayed in the following format: yy:ddd:hh:mm:ss (years:days:hours:minutes:seconds).

Clear Log

This button launches a method to clear the status events in the Diagnostic Log.

7.1.6 Variable Logging

Overview

Variable Logging can be used in a number of ways. The first function is the logging and time-stamping of the minimum and maximum pressures and module temperatures. The second function is logging and time-stamping of over pressure or over temperature conditions, events that could have an effect on the life of the transmitter. shows the Pressure Variable Logging screen. shows the Temperature Variable Logging screen.

Pressure Variable Logging

HART 5 with Diagnostics Fast Keys	3, 2, 2, 1
HART 7 Fast Keys	3, 2, 3, 1

Minimum, Maximum Pressure

The meters indicate the lowest and highest pressure the transmitter has measured since the last time the value was cleared. Time Since Event indicates the elapsed time since the min/max pressure was measured.

Both the Min and Max values can be reset independently.

Clicking on **Reset All Pressure Events** will reset the Time Since Event clock and sets the pressure to the currently measured value.

Figure 7-21: Pressure Variable Logging Screen

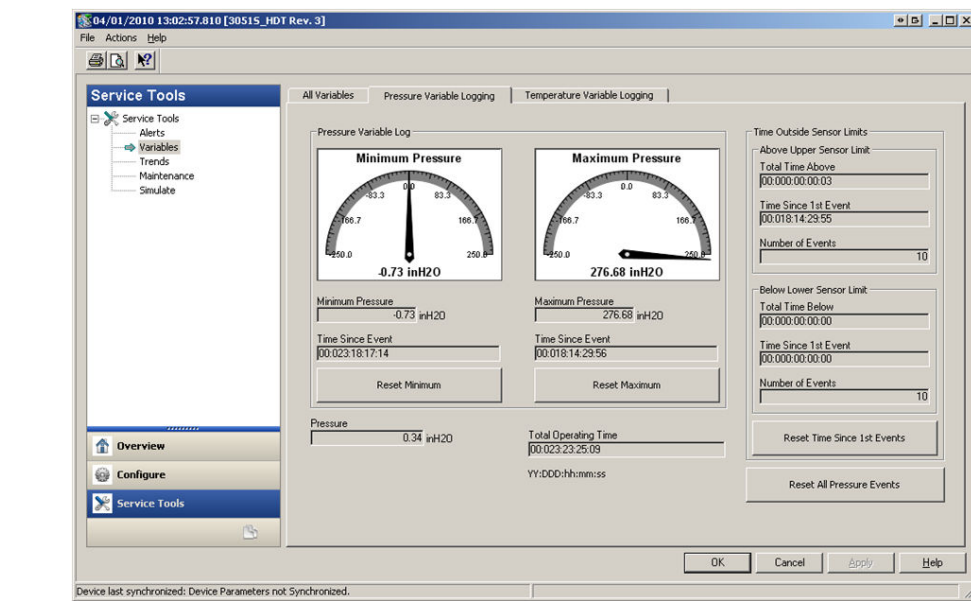

Time Outside Sensor Limits gives the operator/maintenance personnel an indication of possible misapplication of the transmitter. The lower and upper operate the same. They both include a **Time Since 1st Event**, **Number of Events**, and **Total time**.

Total Time Above/Below

This is the accumulated time the pressure sensor has been in an over-pressure condition. This elapsed total time is independent of the number of events or frequency; it is the total or sum time the transmitter was in this condition. These values are not resettable.

Time Since 1st Event

The elapsed time since the first over-pressure was detected. This time can be reset by clicking the **Reset Time Since 1st Events** button.

Number of Events

This is the number of times the pressure sensor has been in an overpressure condition. These values are not resettable.

Reset Time Since 1st Events

Selecting this reset will set the **Time Since 1st Event** for both **Above Upper Sensor Limit** and **Below Lower Sensor Limit** to zero.

Reset All Pressure Events

Selecting this will reset all values on this screen to zero with the exception of Total Operating Time, the Total Time above and below sensor limit, and the Number of Events for above and below sensor limit.

Temperature Variable Logging

HART 5 with Diagnostics Fast Keys	3, 2, 3, 1
HART 7 Fast Keys	3, 2, 4, 1

Minimum, Maximum Temperature

The meter indicates the lowest and highest module temperatures the transmitter has measured since the last time the value was cleared. The Time Since Event indicates the elapsed time since that temperature was measured.

Both the Min and Max values can be reset independently. Selecting on Reset All Temperature Events will reset the Time Since Event clock and sets the temperature to the currently measured value.

Figure 7-22: Temperature Variable Logging Screen

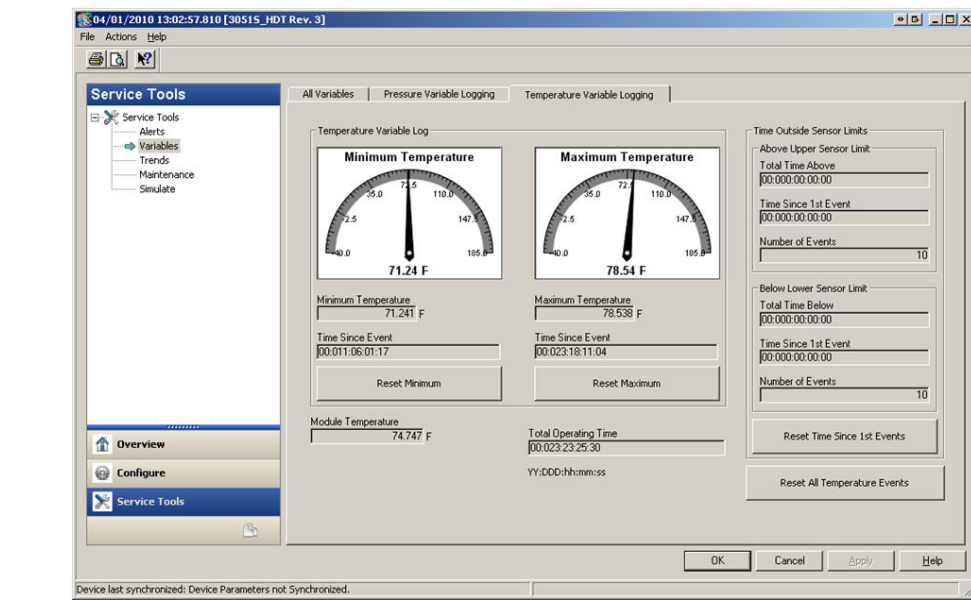

Time Outside Sensor Limits gives the operator/maintenance personnel an indication of possible misapplication of the transmitter. The Lower and Upper operate the same. They both include a Time Since 1st Event, Number of Events, and Total time.

Total Time Above/Below

This is the accumulated time the module temperature sensor has been in an over-temperature condition. This elapsed total time is independent of the number of events or frequency; it is the total or sum time the transmitter was in this condition. These values are not resettable.

Time Since 1st Event

The elapsed time since the first over-temperature was detected. This time can be reset by clicking the Reset Time Since 1st Events button.

Number of Events

This is the number of times the temperature sensor has been in an over-temperature condition. These values are not resettable.

Reset Time Since 1st Events

Selecting this reset will set the Time Since 1st Event for both Above Upper Sensor Limit and Below Lower Sensor Limit to zero.

Reset All Temperature Events

Selecting this will reset all values on this screen to zero with the exception of Total Operating Time, the Total Time above and below sensor limit, and the Number of Events for above and below sensor limit.

7.1.7 Process Alerts

Overview

Process alerts can be used in addition to alarm or alerts generated in the control system to indicate problems with the process or installation.

Pressure Alerts

HART 5 with Diagnostics Fast Keys	2, 3, 4, 1
HART 7 Fast Keys	2, 3, 4, 1

Figure 7-23: Pressure Alerts Screen

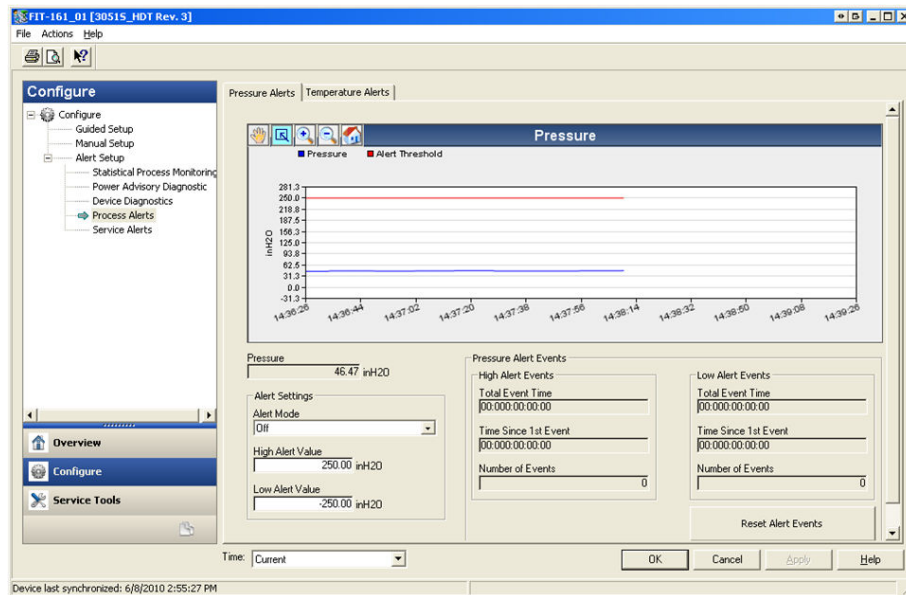

Figure 7-23 shows the configuration section for Pressure Alerts. If applied pressure goes above or below the alert values, the LCD display will indicate a pressure alert and a HART alert will be generated by the transmitter. An active alert will not affect the transmitter's 4–20 mA output signal.

Alert Mode

This setting dictates whether the diagnostic is **On** or **Off**. Selecting **On Unlatched** will generate a HART alert when the alert values are tripped. When pressure returns to normal and within the alert limits, the alert is automatically cleared. Selecting **On Latched** will generate the same HART alert but will require a manual reset to clear the alert.

Latched alert action is recommended if 3rd party alert monitor software is likely to miss alerts due to slow polling of HART data.

High Alert Value/Low Alert Value

These are independent trip values for the diagnostic. These values are represented on the graph by the red lines.

Total Event Time (high/low)

These fields show the total time the transmitter's input pressure was above the High Alert Value or below the Low Alert Value.

Time Since 1st Event (high/low)

This is the elapsed time since the first Pressure Alert event for High Alert Value and Low Alert Value. Subsequent events will increment the Total Event Time values but this value will remain unchanged.

Number of Events (high/low)

This is the number of times the transmitter's input pressure was above the High Alert Value or below the Low Alert Value.

Reset Alert Events

Selecting this will reset all time stamp values and number of events to zero.

Temperature Alerts

HART 5 with Diagnostic Fast Keys	2, 3, 4, 2
HART 7 Fast Keys	2, 3, 4, 2

Figure 7-24: Module Temperature Alert Screen

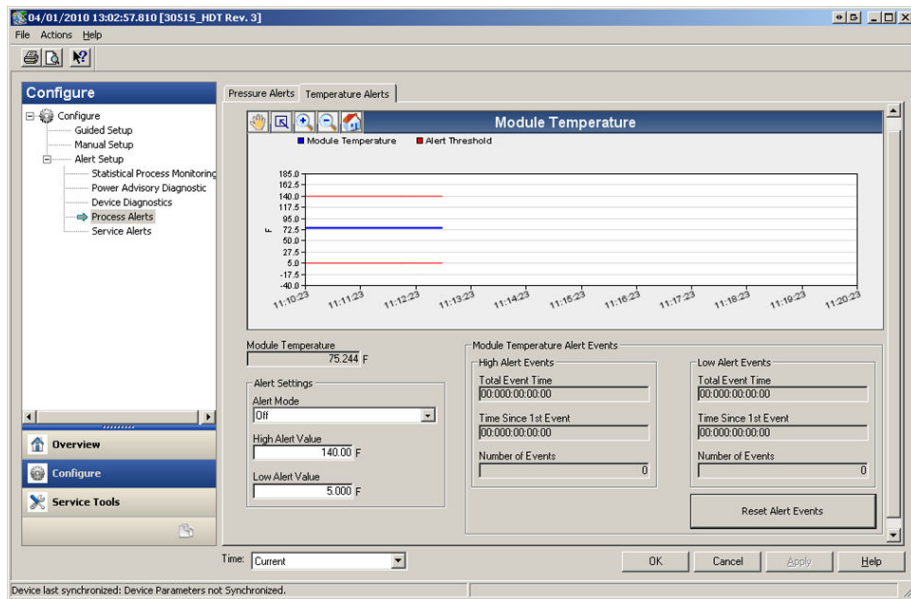

Figure 7-24 shows the configuration section for Temperature Alert. If module temperature goes above or below the alert values, the LCD display will indicate a temperature alert and a HART alert will be generated by the transmitter. An active alert will not affect the transmitter's 4–20 mA output signal.

Alert Mode

This setting dictates whether the diagnostic is **On** or **Off**. Selecting **On Unlatched** will generate a HART alert when the alert values are tripped. When the transmitter's module temperature returns to normal and within the alert limits, the alert is automatically cleared. Selecting **On Latched** will generate the same HART alert but will require a manual reset to clear the alert.

Latched alert action is recommended if third party alert monitor software is likely to miss alerts due to slow polling of HART data.

High Alert Value/Low Alert Value

These are independent trip values for the diagnostic. These values are represented on the graph by the red lines.

Total Event Time (high/low)

These fields show the total time the transmitter's module temperature was above the High Alert Value or below the Low Alert Value.

Time Since 1st Event (high/low)

This is the elapsed time since the first Temperature Alert event for High Alert Value and Low Alert Value. Subsequent events will increment the Total Event Time values but this value will remain unchanged.

Number of Events (high/low)

This is the number of times the transmitter's module temperature was above the High Alert Value or below the Low Alert Value.

Reset Alert Events

Selecting this will reset all time stamp values and number of events to zero.

7.1.8 Service Alerts

HART 5 with Diagnostics Fast Keys	2, 3, 5
HART 7 Fast Keys	2, 3, 5

Overview

Service Alert can be used to generate a time-based HART alert with customizable message. This can be used to remind personnel when to perform maintenance on the transmitter. When the alert is generated, the LCD display will indicate TIMER ALERT and a HART alert will be generated by the transmitter. An active alert will not affect the transmitter's 4–20 mA output signal.

Figure 7-25: Service Alert Screen

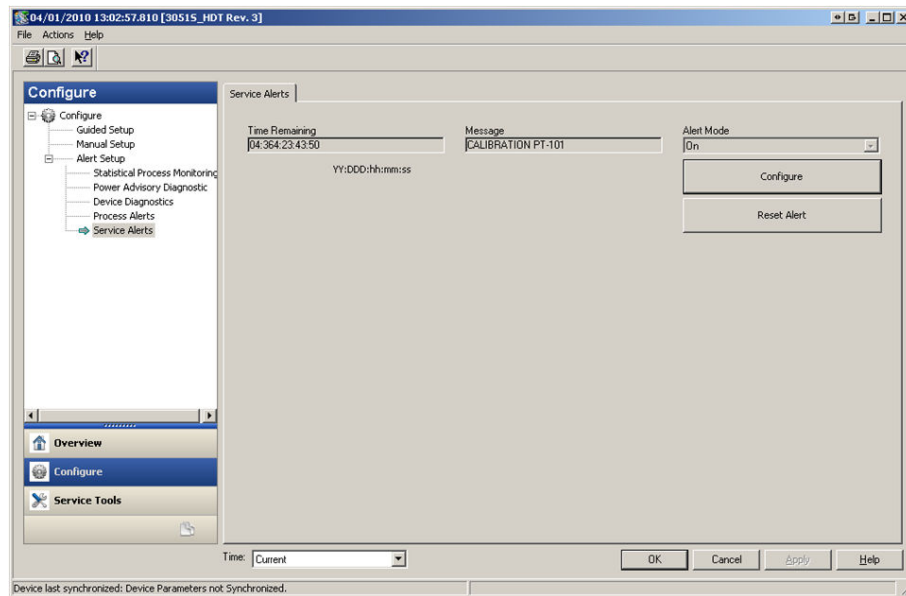

Time Remaining

Amount of time remaining before the HART alert is generated. This value begins counting down to zero as soon as the diagnostic is turned on. Time remaining can be configured in terms of number of years, days, hours, minutes, and seconds.

If transmitter loses power, Time Remaining will not continue to count down. Once powered up again, the timer resumes operation.

Message

User customizable message associated to the Service Alert. The message field can contain up to 32 alphanumeric characters and is stored in the non-volatile memory of the transmitter.

Alert Mode

This indicates whether the diagnostic is turned **On** or **Off**.

Configure

This method controls the Alert Mode of the diagnostic and allows for configuration of timer and message.

Reset Alert

Selecting this will reset the **Time Remaining** value and start the countdown process again.

7.1.9 Device Diagnostics

Overview

In addition to standard device diagnostics that provide notification of when the transmitter fails, the Rosemount 3051S Pressure Transmitter with Advanced HART Diagnostics has predictive device diagnostics that detect issues in the electronics that may result in on-scale failure.

Figure 7-26: Device Diagnostics Screen

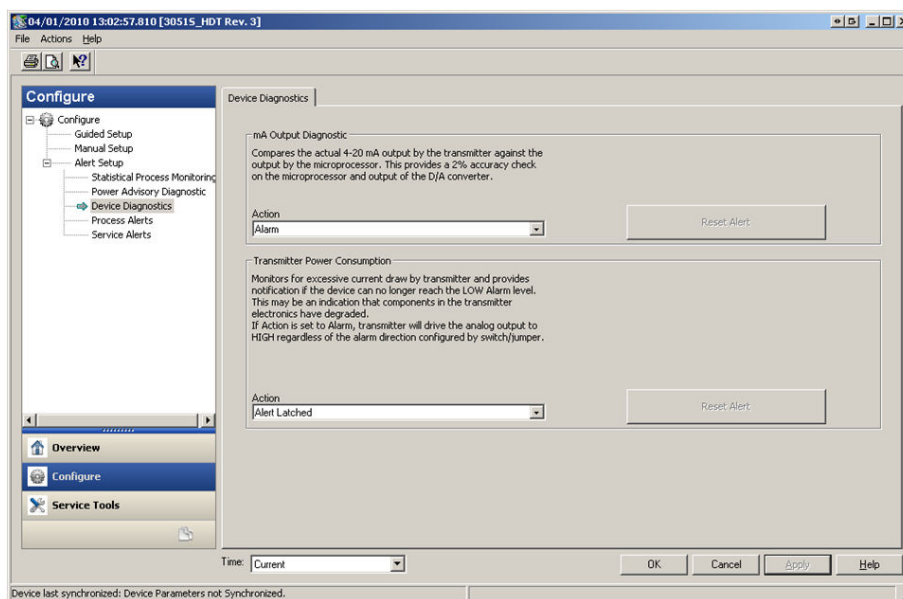

mA Output Diagnostic

The mA Output Diagnostic measures the actual 4–20 mA output from the transmitter’s Digital-to-Analog converter and compares it against the output by the transmitter’s microprocessor. If the measured value deviates from the expected value by 2 percent or more, the diagnostic will generate an alarm or alert.

Note

The default trip action for mA Output Diagnostic is set to Alarm. For use in SIS, the trip action must not be changed or the proper safety coverage stated on the FMEDA will not be realized.

Transmitter Power Consumption

Transmitter Power Consumption diagnostic monitors for excessive current draw by the transmitter. This diagnostic is used to detect a potential on-scale failure due to current leakage or failing electronics.

Note

If trip action is set to Alarm, the transmitter will drive the 4–20 mA output to fail HIGH regardless of the alarm direction configured by the alarm switch.

7.1.10

Emerson Wireless 775 THUM™ Adapter Configuration with Advanced Diagnostics

Overview

Many older legacy control systems that only use analog cannot take full advantage of HART diagnostics or additional process variables. The Emerson Wireless 775 THUM Adapter can transmit up to four process variables and additional HART status information at the user configurable update rate.

The selectable process variables are:

- **Pressure**
- **Module Temperature**
- **Scaled Variable**
- **Standard Deviation**
- **Mean**
- **Coefficient of Variation**

Installation and commissioning

Figure 7-27: Wiring Diagram for 2-Wire Device

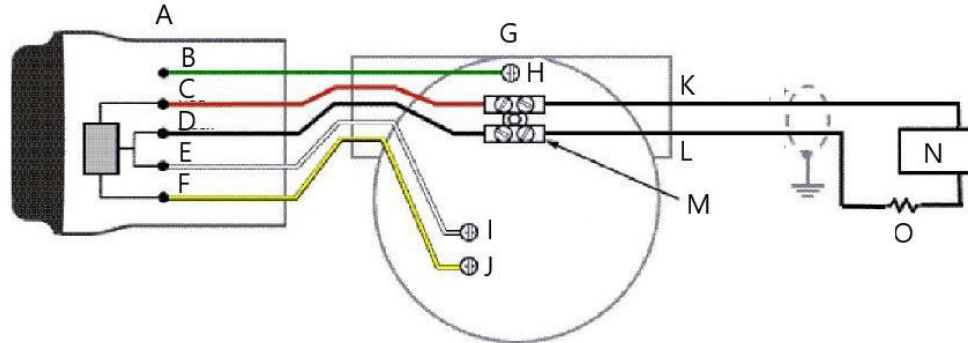

- A. THUM Adapter
- B. Green
- C. Red
- D. Black
- E. White
- F. Yellow
- G. Wired device
- H. Ground
- I. - PWR/COMM
- J. + PWR/COMM
- K. 4-20 mA loop +
- L. 4-20 mA loop -
- M. Splice connector
- N. Power supply
- O. Load resistor $\geq 250 \Omega$

Below are the four major steps to commission the Rosemount 3051S with Advanced Diagnostics and THUM Adapter. Further detail on these steps can be found in the [Emerson Smart Wireless THUM Adapter Reference Manual](#).

Procedure

1. Check the 3051S variable assignments (SV, TV, QV) and remap as necessary to assign variables intended for use with the THUM Adapter.
2. Configure the **Network ID** and **Join Key** in order for the THUM Adapter to join wireless network.
3. Configure **Update Rate** for the THUM Adapter.
Update Rate is the frequency at which HART data is taken and transmitted over the wireless network.

Note

The THUM Adapter has a minimum update rate of eight seconds and may not capture alerts that appeared in between updates. Emerson recommends setting diagnostic trip action to **Alert Latched** to minimize chance of missed alerts in between updates.

4. Connect the 3051S with Advanced Diagnostics to the THUM Adapter, as shown in [333 HART Tri-Loop Wiring Diagram](#), and make sure there is at least 250 Ohms resistance in the loop.

Note

When using the Loop Integrity diagnostic and the THUM Adapter to detect changes on the electrical loop, a re-characterization of the loop must be performed when the THUM Adapter is installed for the first time.

7.1.11 Rosemount 333 Hart Tri-Loop Configuration with Advanced Diagnostics

Overview

The 333 HART Tri-Loop can be used in conjunction with the 3051S with Advanced HART Diagnostics to acquire up to three more variables via 4–20 mA analog signals.

The selectable process variables are:

- **Pressure**
- **Temperature**
- **Scaled Variable**
- **Standard Deviation**
- **Mean**
- **Coefficient of Variation**

Installation and commissioning the Rosemount 3051S and Tri-Loop

Below are the four major steps to commission the 3051S and Tri-Loop. Further detail on these steps can be found in the [333 HART Tri-Loop HART-to-Analog Signal Converter Reference Manual](#).

Procedure

1. Check the 3051S with Advanced Diagnostics variable mapping and remap as necessary to assign the three variables intended to be the Tri-Loop output. Take note of the variable information including variable, variable name, and variable units as it will be necessary to duplicate this exactly in the Tri-Loop for proper operation. Some useful variables for process diagnostics include Standard Deviation, Mean, Coefficient of Variation, and Module Temperature.

Note

The measured pressure will continue to be reported as a 4–20 mA value via the primary variable output.

2. Connect the 3051S with Advanced Diagnostics to the 333 Tri-Loop. The 3051S with Advanced Diagnostics 4–20 mA output connects to the 333 Tri-Loop Burst Input. See [Figure 7-28](#).

Figure 7-28: 333 HART Tri-Loop Wiring Diagram

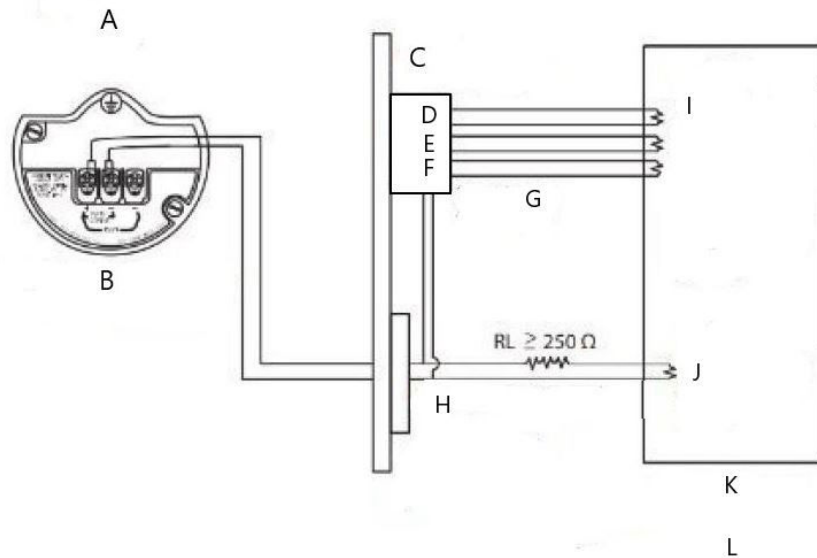

- A. Hazardous area
- B. 3051S with advanced diagnostics
- C. DIN rail mounted HART Tri-loop
- D. Channel 3
- E. Channel 2
- F. Channel 1
- G. Burst input to Tri-loop
- H. HART burst command 3/Analog output intrinsically safe barrier
- I. Each Tri-loop channel receives power from Control Room. Channel 1 must be powered for the Tri-loop to activate.
- J. Device receives power from Control Room
- K. Control Room
- L. Non-hazardous area

3. Configure the 333 HART Tri-Loop.

The channel configuration must be identical to the variables mapped in the 3051S with Advanced Diagnostics.

Note

The 333 HART Tri-Loop default address is 1. The HART host must be configured to Poll for the 333 HART Tri-Loop in order to find it.

4. Enable **Burst** mode in the 3051S with Advanced Diagnostics.

The Burst Mode must be **On** and the Burst Option must be set to **Process Vars/Crnt**.

A Appendix A: Specifications and Reference Data

A.1 Product Certifications

To view current Rosemount™ 3051S Product Certifications, see the [3051S Series Pressure Transmitter Quick Start Guide](#).

A.2 Ordering Information, Specifications, and Drawings

To view current Rosemount 3051S ordering information, specifications, and drawings, see the [3051S Series of Instrumentation Product Data Sheet](#) on [Emerson.com/global](https://www.emerson.com/global).

For more information: [Emerson.com/global](https://emerson.com/global)

©2024 Emerson. All rights reserved.

Emerson Terms and Conditions of Sale are available upon request. The Emerson logo is a trademark and service mark of Emerson Electric Co. Rosemount is a mark of one of the Emerson family of companies. All other marks are the property of their respective owners.

ROSEMOUNT™

