

GE
Intelligent Platforms

Programmable Control Products

PACSystems* RSTi I/O Manual

User Manual, GFK-2745B

July 2014



Warnings, Cautions, and Notes

Warning

Warning notices are used in this publication to emphasize that hazardous voltages, currents, temperatures, or other conditions that could cause personal injury exist in this equipment or may be associated with its use. In situations where inattention could cause either personal injury or damage to equipment, a Warning notice is used.

- Installing or removing modules or wiring with power applied to the system or field wiring can cause an electrical arc. This can result in unexpected and potentially dangerous action by field devices. Arcing is an explosion risk in hazardous locations. Be sure that the area is non-hazardous or remove power appropriately before installing or removing modules or wiring.
- Potentially dangerous voltages are present on a module's terminals, even when system power is turned off. Field power must be turned off when installing or removing a terminal block assembly.
- Personnel, who install, operate and maintain automation systems that contain these products must be trained and qualified to perform those functions.
- Overloading power modules or Network adapter can result into electric arc & damage to modules.

Caution

Caution notices are used where equipment might be damaged if care is not taken.

- Check the rated voltage and terminal array before wiring.
- Ensure that specified environmental conditions are not exceeded. Avoid placing the module in direct sunlight.
- Review module specifications carefully, and ensure that input and output connections are made in accordance with the specifications.
- Use specified cables for wiring.
- Field power isolators must be used according to the requirements of the 5VDC/24VDC/48VDC or AC Voltage modules used in the system.
- If system power consumption exceeds the power limits, use system power expansion modules.
- Make sure power supplies for system power and field power must be supplied from separate sources.

Note: Notes merely call attention to information that is especially significant to understanding and operating the equipment.

This document is based on information available at the time of its publication. While efforts have been made to be accurate, the information contained herein does not purport to cover all details or variations in hardware or software, or to provide for every possible contingency in connection with installation, operation, or maintenance. Features may be described herein which are not present in all hardware and software systems. GE Intelligent Platforms assumes no obligation of notice to holders of this document with respect to changes subsequently made.

GE Intelligent Platforms makes no representation or warranty, expressed, implied, or statutory with respect to, and assumes no responsibility for the accuracy, completeness, sufficiency, or usefulness of the information contained herein. No warranties of merchantability or fitness for purpose shall apply.

Contact Information

If you purchased this product through an Authorized Channel Partner, please contact the seller directly.

General Contact Information

Online technical support and Global Care	http://support.ge-ip.com
Additional information	http://www.ge-ip.com/
Solution Provider	solutionprovider.ip@ge.com

Technical Support

If you have technical problems that cannot be resolved with the information in this manual, please contact us by telephone or email, or on the web at <http://support.ge-ip.com>

Americas

Online Technical Support	http://support.ge-ip.com
Phone	1-800-433-2682
International Americas Direct Dial	1-780-420-2010 (if toll free 800 option is unavailable)
Technical Support Email	support.ip@ge.com
Customer Care Email	customercare.ip@ge.com
Primary language of support	English

Europe, the Middle East, and Africa

Online Technical Support	http://support.ge-ip.com
Phone	+800-1-433-2682
EMEA Direct Dial	+420-23-901-5850 (if toll free 800 option is unavailable or if dialing from a mobile telephone)
Technical Support Email	support.emea.ip@ge.com
Customer Care Email	customercare.emea.ip@ge.com
Primary languages of support	English, French, German, Italian, Czech, Spanish

Asia Pacific

Online Technical Support	http://support.ge-ip.com
Phone	+86-400-820-8208 +86-21-3217-4826 (India, Indonesia, and Pakistan)
Technical Support Email	support.cn.ip@ge.com (China) support.jp.ip@ge.com (Japan) support.in.ip@ge.com (remaining Asia customers)
Customer Care Email	customercare.apo.ip@ge.com , customercare.cn.ip@ge.com (China)

Introduction.....	1
List of RSTi Modules.....	4
PACSystems Documentation	7
Installation.....	8
Power Modules	13
ST-7008	14
ST-7108	17
ST-7111	20
ST-7118	23
ST-7188	26
ST-7241	28
ST-7408	31
ST-7508	34
ST-7511	37
ST-7518	40
ST-7588	43
ST-7641	46
Dimension	49
Diagnostics	50
Discrete Inputs.....	51
ST-1114	52
ST-1124	54
ST-1214	56
ST-1218	58
ST-121F	60
ST-1224	62
ST-1228	64
ST-122F	66
ST-1314	68
ST-131F	70
ST-1324	72
ST-1804	74
ST-1904	76
Dimension	78
Mapping Data into the Image Table.....	80
Diagnostics	81
Discrete Outputs.....	82
ST-2114	83
ST-2124	85
ST-2314	87
ST-2324	89
ST-2414	91

Contents

ST-2424	93
ST-2514	95
ST-2524	97
ST-2318	99
ST-2328	101
ST-221F	103
ST-222F	105
ST-2742	107
ST-2744	109
ST-2748	111
ST-2852	113
Dimension	115
Mapping Data into the Image Table.....	117
Analog Inputs.....	119
ST-3114	120
ST-3118	122
ST-3134	124
ST-3214	126
ST-3218	128
ST-3234	130
ST-3424	132
ST-3428	134
ST-3444	136
ST-3524	138
ST-3544	140
ST-3624	142
ST-3644	144
ST-3702	146
ST-3704	149
ST-3708	151
ST-3802	153
ST-3804	155
ST-3808	157
Dimension	159
Mapping Data into the Image Table.....	161
Current and Voltage Mode.....	171
Diagnostics	180
Analog Output.....	182
ST-4112	183
ST-4114	185
ST-4212	187
ST-4214	189
ST-4422	192
ST-4424	194
ST-4491	197

ST-4522	199
ST-4622	201
ST-4911	203
Dimension	205
Mapping Data into the Image Table.....	206
Current and Voltage Mode.....	209
Diagnostics	214
Special Modules.....	215
High Speed Counter Modules.....	216
Serial Module	249
SSI Interface	277
PWM Output Module.....	282
Pulse Output Module	294
Accessories.....	309
Configuration Parameter and Memory Register	310
Configuration Parameter.....	316
Memory Register.....	345
Product Certifications and Installation Guidelines for Conformance	0
Important Notes	1
Environmental Specifications.....	3
Government Regulations	3
Abbreviations	5

The PACSystems RSTi Network Interface and I/O family provides a cost effective, modular distributed I/O system. The RSTi network is ideally suited for distributed applications such as water/wastewater, process control, packaging and assembly. You can easily add RSTi modules to the system to build functional remote I/O stations to meet your application requirements.

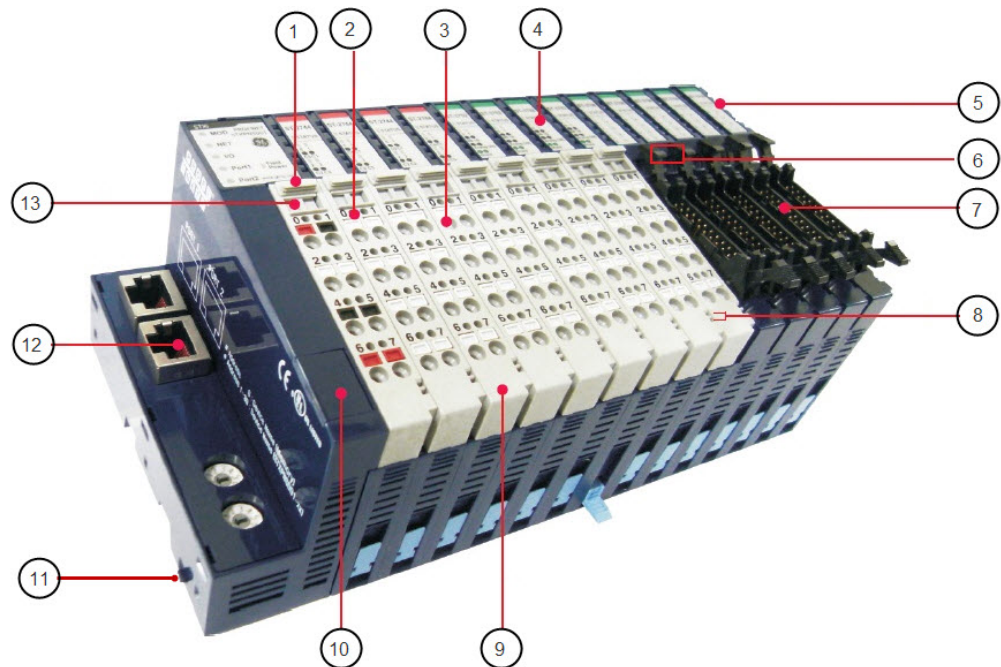

Sr. Number	Label
①	Removable Switch of Terminal Block
②	Tester Pin Hole
③	Screw less Connection System
④	I/O Status Display LED
⑤	System-Data Pin (6 Pins)

Sr. Number	Label
6	Module Number Marking (Header Type)
7	Header Type Module (16 points)
8	Field Power Pin (2 pins)
9	RTB (Removable Terminal Block)
10	Reserved communication Port (Useful to only manufacturer)
11	PUSH Lock for DIN rail
12	Fieldbus Connector
13	Module Number Marking (RTB Type)

A set of interconnected RSTi modules can be chosen to suit the application and connected as a slave on a PROFIBUS or a PROFINET network. An RSTi Network Adapter provides the interface between the network and the RSTi modules. The Network Adapter and I/O modules selected for an application constitute an I/O station. The available network adapters for various protocols are PROFIBUS, PROFINET, Modbus, DeviceNet, CANOpen and CC-Link.

I/O Station Capacity

- Up to 32 IO devices can be connected to a Network Adapter. The power consumption of all the modules in the node should be calculated and ensured that it does not exceed the capacity of Network Adapter and power modules.

Installation

The Network Adapter must be connected to the left of the other RSTi modules in the I/O station.

Within the RSTi station, the bus connection, power supply, and power distribution are completed by connecting modules together on the DIN rail. Sensors and actuators are wired to the RSTi modules using spring clamp terminals on the module's removable terminal strips. These terminal strips can be keyed so that they cannot be accidentally swapped. If a module must be replaced, the wiring does not need to be removed; just remove the terminal strip from the module.

RSTi Network Adapter with Integrated digital I/O is available. It combines the advantages of slice-type and block-type construction and offers reduced system design and maintenance costs.

Features

- Modules can be easily installed and connected without tools.
- Flexible and modular structure allows I/O stations to be easily expanded.
- A comprehensive selection of I/O modules supports a wide range of applications.
- Uses small removable terminal blocks to conserve panel space and save time making system connections.
- Module-based diagnostic functions
- The amount of costly parallel wiring is reduced. Within a station, voltage and data routing can be carried out without additional wiring, reducing the cabinet space needed.
- Different parts of the system can be operated independent of one another. This means that pretests can be carried out when the system is set up and that the whole system can be adapted and expanded.

IOGuidePro Tool

PACSystems RSTi Network adapters can be configured & monitored using IOGuidePro tool.

You can use the IOGuidePro Tool to monitor & configure the following data:

- Online monitoring & configuration of MODBUS serial & TCP Network adapters.
- Offline configuration of PROFIBUS & DeviceNet Network adapters.
- RSTi Network adapter & IO node over view.
- Power consumption details.
- IO module configuration parameters & memory map.
- RSTi Network adapter & IO module technical help.

For more information refer the help section of IOGuidePro tool.

List of RSTi Modules

This module consists of the following RSTi Modules:

Power Modules

- ST-7008 Potential Distributor, Shield, 8 points, 10A No LED
- ST-7108 Potential Distributor, 0VDC, 8 points, 10A
- ST-7111 Expansion Power Distributor, 24VDC, 1 A 5VDC booster
- ST-7118 Potential Distributor, 24VDC, 8 points, 10A
- ST-7188 Potential Distributor, 24VDC 4 points
- ST-7241 Expansion Field Power Distribution, 5, 24, 48, AC 10 Amp no LED status
- ST-7408 Potential Distribution for Shield module, ID type with LED
- ST-7508 Potential Distributor for 0VDC, ID type with LED
- ST-7511 24VDC Expansion power module 5 VDC booster, 1 amp with LED
- ST-7518 Potential Distributor for 24VDC, 10 A ID type with status LEDs
- ST-7588 Common for 0VDC and 24VDC
- ST-7641 Isolated Field Distributor 5, 24, 48, AC, 10 amp with LED status

Discrete Inputs

- ST-1114 Digital Input 4 Points, Positive Logic, Terminal, 5Vdc
- ST-1124 Digital Input 4 Points, Negative Logic, Terminal, 5Vdc
- ST-1214 Digital Input 4 Points, Positive Logic, Terminal, 12V/24Vdc
- ST-1218 Digital Input 8 Points, Positive Logic, Terminal, 12V/24Vdc
- ST-121F Digital Input 16 Points, Positive Logic, 20P Connector, 12V/ 24Vdc
- ST-1224 Digital Input 4 Points, Negative Logic, Terminal, 12/24Vdc
- ST-1228 Digital Input 8 Points, Negative Logic, Terminal, 12V/24Vdc
- ST-122F Digital Input 16 Points, Negative Logic, 20P Connector, 12V/ 24Vdc
- ST-1314 Digital Input 4 Points, Positive Logic, Terminal, 48Vdc
- ST-131F Digital Input 16 Points, Positive Logic, 20P Connector, 48Vdc
- ST-1324 Digital Input 4 Points, Negative Logic, Terminal, 48Vdc
- ST-1804 Digital Input 4 Points, 110Vac (AC 85V~132V)
- ST-1904 Digital Input 4 Points, 240Vac (AC 170V~264V)

Discrete Outputs

- ST-2114 Digital Output 4 Points, TTL Inverting (Positive Logic), 5Vdc/20mA
- ST-2124 Digital Output 4 Points, TTL Non-Inverting (Positive Logic), 5Vdc/20mA
- ST-2314 Digital Output 4 Points, Negative Logic, Terminal, 24Vdc/0.5A
- ST-2324 Digital Output 4 Points, Positive Logic, Terminal, 24Vdc/0.5A
- ST-2414 Digital Output 4 Points, Negative Logic, Terminal, Diagnostics, 24Vdc/0.5A
- ST-2424 Digital Output 4 Points, Positive Logic, Terminal Diagnostics, 24VDC/0.5A
- ST-2514 Digital Output 4 Points, Negative Logic, Terminal, Diagnostics, 24Vdc/2A
- ST-2524 Digital Output 4 Points, Positive Logic, Terminal, Diagnostics, 24Vdc/2A

- ST-2318 Digital Output 8 Points, Negative Logic, Terminal, 24Vdc/0.5A
- ST-2328 Digital Output 8 Points, Positive Logic Terminal, 24Vdc/0.5A
- ST-221F Digital Output 16 Points, Negative Logic, 20P Connector, 24Vdc/0.5A
- ST-222F Digital Output 16 Points, Positive Logic, 20P Connector, 24Vdc/0.5A
- ST-2742 Isolated Relay Output 2 Points, Terminal, 240Vac/2A
- ST-2744 Isolated Relay Output 4 Points, Terminal, 240Vac/2A
- ST-2748 Isolated Relay Output 8 Points, Terminal, 240Vac/2A
- ST-2852 Triac Output 2 Points, 12V~125VAC/0.5A

Analog Inputs

- ST-3114 AI 4 Channels, 0~20mA, 12-bit
- ST-3118 AI 8 Channels, 0~20mA, 12bit
- ST-3134 AI 4 Channels, 0~20mA, 14-bit
- ST-3214 AI 4 Channels, 4~20mA, 12-bit
- ST-3218 AI 8 Channels, 4~20mA, 12bit
- ST-3234 AI 4 Channels, 4~20mA, 14-bit
- ST-3424 AI 4 Channels, 0~10Vdc, 12-bit
- ST-3428 AI 8 Channels, 0~10V, 12bit
- ST-3444 AI 4 Channels, 0~10Vdc, 14-bit
- ST-3524 AI 4 Channels, -10~+10Vdc, 12-bit
- ST-3544 AI 4 Channels, -10~+10Vdc, 14-bit
- ST-3624 AI 4 Channels, 0~5Vdc, 12-bit
- ST-3644 AI 4 Channels, 0~5Vdc, 14-bit
- ST-3702 AI 2 Channels, RTD
- ST-3704 AI 4 Channels, RTD Connector Type
- ST-3708 AI 8 Channels, RTD Connector Type
- ST-3802 AI 2 Channels, Thermocouple
- ST-3804 AI 4 Channels, Thermocouple Connector Type
- ST-3808 AI 8 Channels, Thermocouple Connector Type

Analog Outputs

- ST-4112 AO 2 Channels, 0~20mA, 12-bit
- ST-4114 AO 4 Channels, 0~20mA, 12bit
- ST-4212 AO 2 Channels, 4~20mA, 12-bit
- ST-4214 AO 4 Channels, 4~20mA, 12bit
- ST-4422 AO 2 Channels, 0~10Vdc, 12-bit
- ST-4424 AO 4 Channels, 0~10Vdc, 12bit
- ST-4491 AO 1 Channel, 0~10V, 12bit, Manual type
- ST-4522 AO 2 Channels, -10~+10Vdc, 12-bit
- ST-4622 AO 2 Channels, 0~5Vdc, 12-bit
- ST-4911 AO 1 Channel, 0~1 A, 12bit

Special Modules

- ST-5101 High Speed Counter, 1 Channel, 5VDC 1.5MHz
- ST-5111 High Speed Counter, 1 Channel, 24VDC 1.5MHz
- ST-5112 High Speed Counter, 2 Channel, 24VDC, 100Khz
- ST-5114 High Speed Counter, 4 Channel, 24VDC, 50Khz
- ST-5211 Serial Interface RS-232C, 1 Channel
- ST-5212 Serial Interface RS-232C, 2 Channels
- ST-5221 Serial Interface RS-422, 1 Channel
- ST-5231 Serial Interface RS-485, 1 Channel
- ST-5232 Serial Interface RS-485, 2 Channels
- ST-5351 SSI Interface 1 CH; 62.5K, 100K, 125K,250K,500K,1M,2Mbps
- ST-5422 2 Channels, PWM Output, 1.5A/24VDC, Positive Logic
- ST-5442 2 Channels, PWM Output, 0.5A/24VDC, Positive Logic
- ST-5444 4 Channels, PWM Output, 0.5A/24VDC, Positive Logic
- ST-5641 1 Channel, Pulse Output, 0.5A/24VDC, Positive Logic
- ST-5642 2 Channels, Pulse Output, 0.5A/24VDC, Positive Logic
- ST-5651 1 Channel, Pulse Output, 0.5A/5V (RS422)

Accessories

- STXACC001 Numbering, 0~9, White, 100EA
- STXACC002 Numbering, Blank, 100EA
- STXACC004 End Module, 7pcs
- STXRTB009 Removable Terminal Block, 9pcs
- STXRTB109 Removable Terminal Block, 9pcs for STXxxx Network Interface Modules except STXDNSxxx, ST-7x11
- STXRTB209 Removable Terminal Block, 9pcs for STXDNSxxx and ST-7x41

PACSystems Documentation

- RSTi Profinet & Profibus Network Adapter Manual - GFK 2746
- RSTi Modbus Network Adapter Manual - GFK 2799
- RSTi DeviceNet Network Adapter Manual – GFK 2801
- RSTi CANopen Network Adapter Manual – GFK 2807
- RSTi CC Link Network Adapter Manual – GFK 2809

Module Mounting

How to mount on Din-Rail

1. Press down the module lightly on the Din-Rail until it clicks.

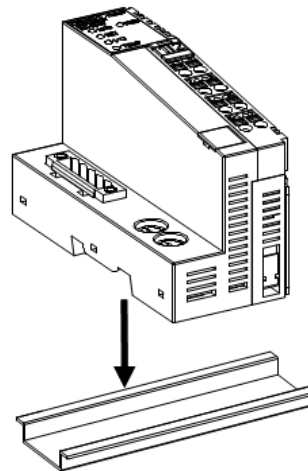

2. You can use the PUSH lock for DIN rail as a second locking mechanism. This lock will maintain module intact to DIN rail.

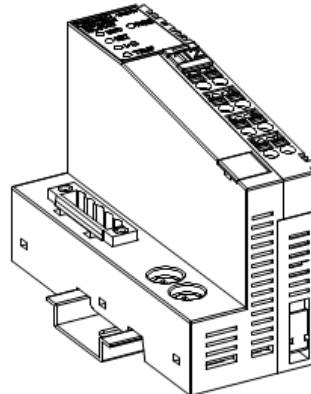

How to dismount from Din-Rail

1. Pull down the locking mechanism by using a small flat screw driver as shown in the following illustration.

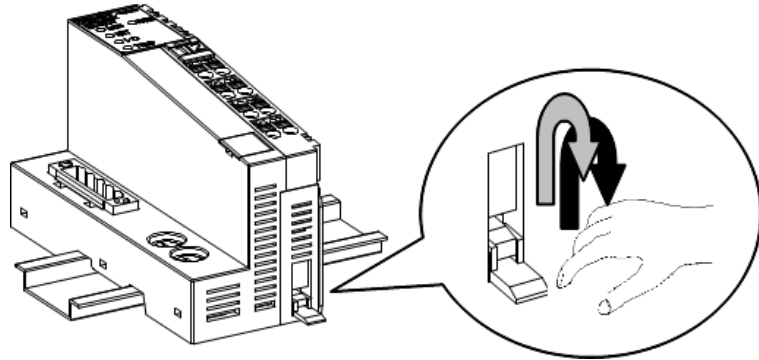

2. Push the lock on the side of module, pull up the module to remove from the din rail.

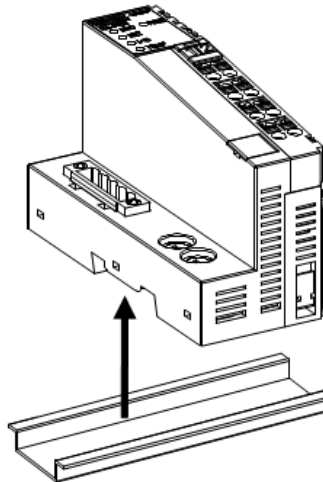

Installing and Removing Components

To plug in the module use a small-bladed screwdriver and push down the locking lever located at bottom of the module. Install the module on DIN rail firmly; push up the locking lever to lock. To pull out the RSTi module, push down the locking lever rail.

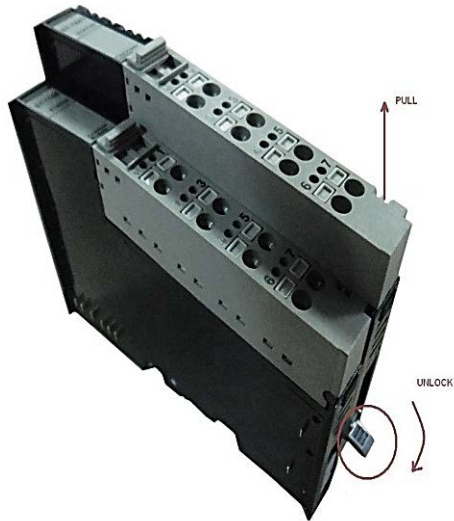

Internal Bus/Field Power Contacts

Communication between the Network adapters and the IO module as well as system / field power supply of the bus modules is carried out via the internal bus. It is comprised of 6 data pins and 2 field power pins.

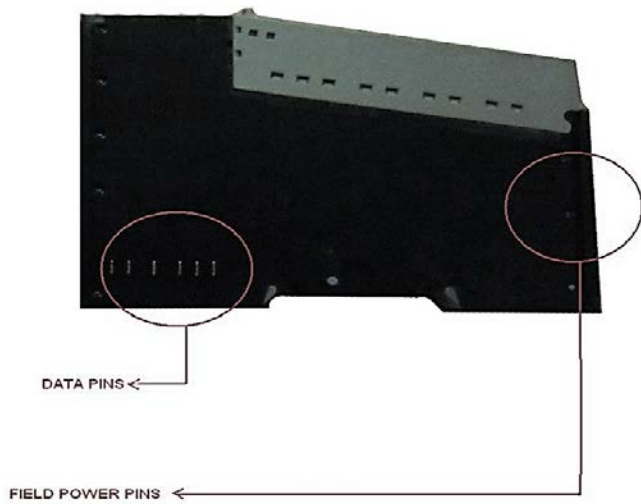

RSTi IO Station spacing

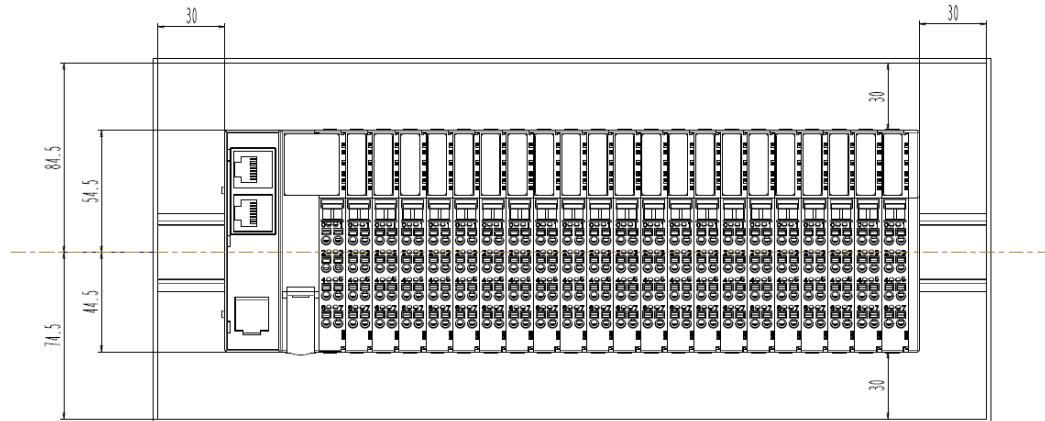

All the dimensions mentioned are in 'mm'.

RSTi Network adapter and IO modules should be mounted horizontally with minimum clearance as shown above to meet product performance and reliability specifications by providing adequate airflow around the modules. Other mounting orientations may affect system performance, reliability and agency approvals, and are therefore not recommended.

Connecting Cables

Connecting Unshielded Cables

Unshielded cables for I/O devices and supply voltages are connected using the spring clamp terminals. Signals up to 250VAC/DC and 5A with a conductor cross-section of AWG 14 – 24 can be connected.

For terminal assignments, please consult the appropriate module data sheet.

Follow these steps when wiring:

1. Strip 8mm (0.3in.) off the cable. Module wiring is normally done without ferrules. However, it is possible to use ferrules. If using ferrules, make sure they are properly crimped.
2. Push a screwdriver into the slot for the appropriate connection (#1 above) so that you can plug the wire into the spring opening.
3. Insert the wire (#2 above). Pull the screwdriver out of the opening. The wire is clamped.

Connecting Shielded Cables

Observe the following when installing shielding:

1. Strip the outer cable sheath to the desired length. The appropriate length depends on the connection position of the wires and whether there should be a large or a small space between the connection point and the shield connection.
2. Shorten the braided shield to 15mm (0.6 in.) (#1 above).
3. Fold the braided shield back over the outer sheath. (#2 above)
4. Remove the protective foil.
5. Strip 8mm (0.3in.) off the wires. (#2 above)
6. Open the shield connector (#3 above).
7. Check the orientation of the shield clamp in the Shielded Terminal Strip and change its position if necessary (see below for instructions).
8. Place the cable with the folded braided shield in the shield connector. (#4 above)
9. Close the shield connector (#5 above).
10. Fasten the screws for the shield connector using a screwdriver. (#6 above).

†† The maximum pull strength should not go beyond 10 kgF.

RSTi Bus Data Pin & Field Power Pin Description

No.	Name	Description
1	Vcc	System supply voltage (5V dc)
2	GND	System Ground
3	Token Output	Token output port of Processor module
4	Serial Output	Transmitter output port of Processor module
5	Serial Input	Receiver input port of Processor module
6	Reserved	Reserved for bypass Token
7	Field GND	Field Ground
8	Field Vcc	Field supply voltage (24Vdc)

Table 1: RSTi Bus Pin Name and Description

RSTi Data Bus System

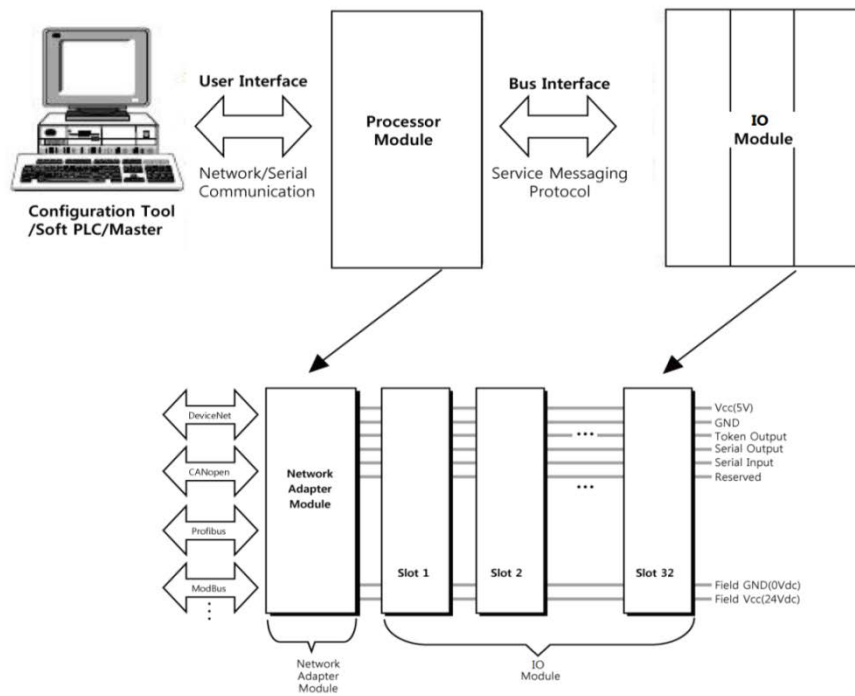

- **Network Adapter Module:** The Network Adapter Module forms the link between the field bus and the field devices through IO Modules. The connection to different field bus systems can be established by each of the corresponding Network Adapter Modules: PROFIBUS, CANopen, DeviceNet, Ethernet/IP, CC-Link, MODBUS/Serial, MODBUS/TCP, PROFINET etc.
- **IO Module:** The IO Modules are supported by a variety of input and output field devices. There are digital and analog input/output modules and special function modules.
- **Two types of Bus Message**
 - Service Messaging
 - I/O Messaging

The Power Supply Modules prevent the lack of power capacity within Network Adaptor module during expansion of module.

There is also a Field Power Distributor to divide the AC and DC from Field Power during module expansion.

ST-7008

Interface and Data

The following illustration shows the interface design for ST-7008.

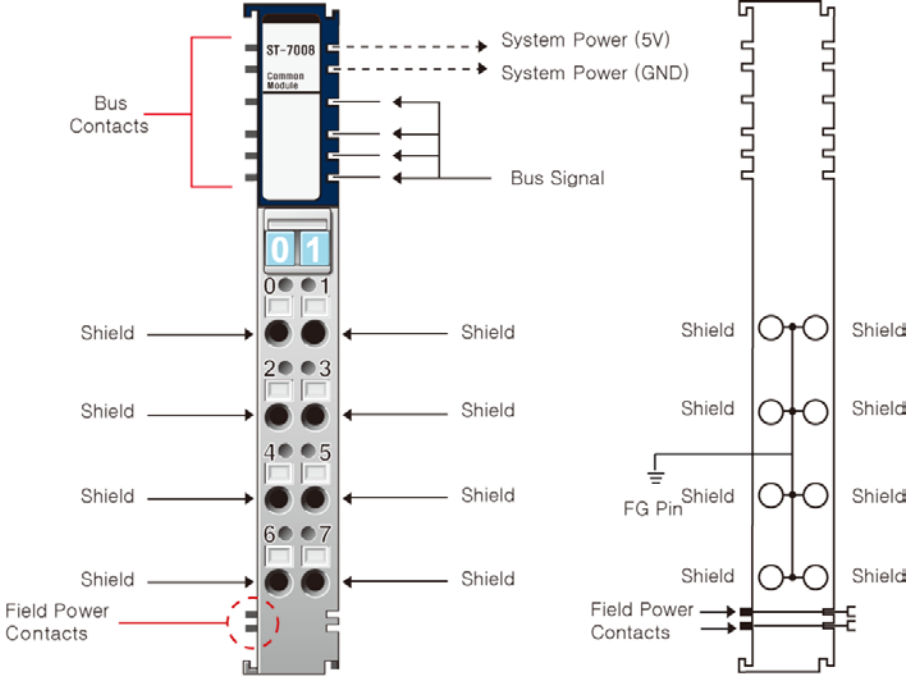

Figure 1: Power Modules: ST-7008

The following table lists the pin numbers and description for ST-7008.

Table 2: ST-7008: Pin Description

Pin Number	Description	Pin Number	Description
0	Shield	1	Shield
2	Shield	3	Shield
4	Shield	5	Shield
6	Shield	7	Shield

Specification

The following table describes the Input Specifications and the General Specifications for ST-7008.

Table 3: ST-7008: Input and General Specifications

Items	Specification
Input Specification	
Field Power Voltage	Shield signal
Contacts Current	Maximum 10A
Indicators	Non Indicate
RSTi Bus Power Contactor	Yes
General Specification	
Power Dissipation	Expansion Power Distributor
Wiring	I/O Cable Maximum 2.0mm ² (AWG 14)
Weight	65g Maximum
Module Size	12mm x 99mm x 70mm
Environment Condition	See "Environmental Specifications" in Appendix A.

Example

The following illustration shows an example of ST-7008 providing shield.

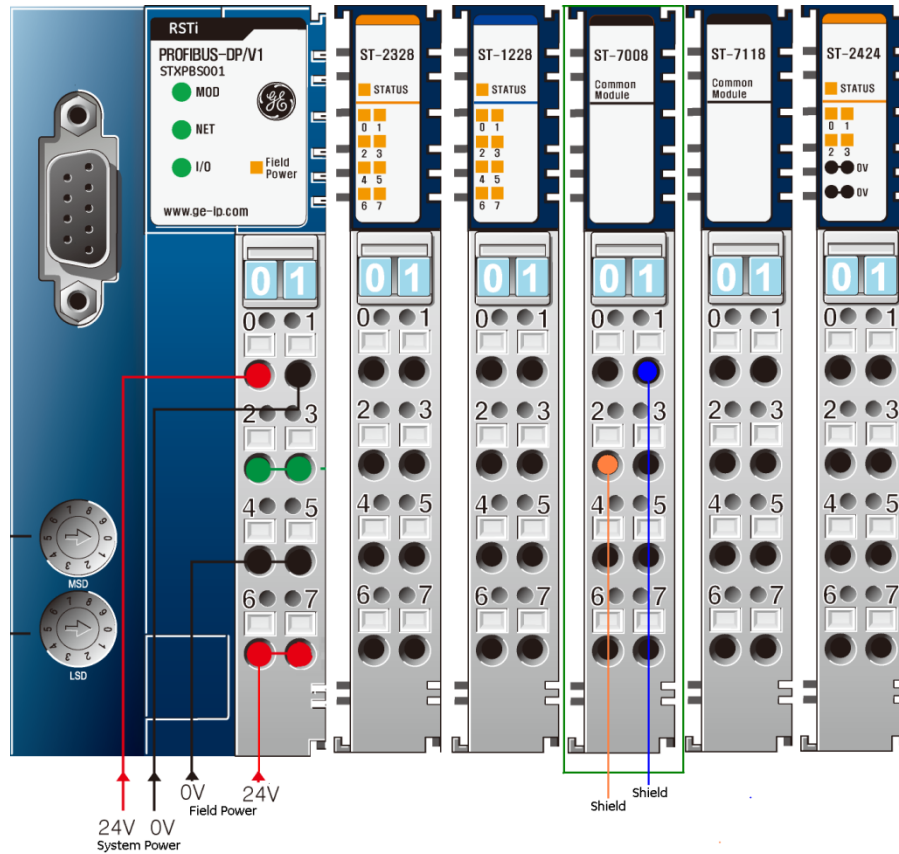

Figure 2: Example: ST-7008

ST-7108

Interface and Data

The following illustration shows the interface design for ST-7108.

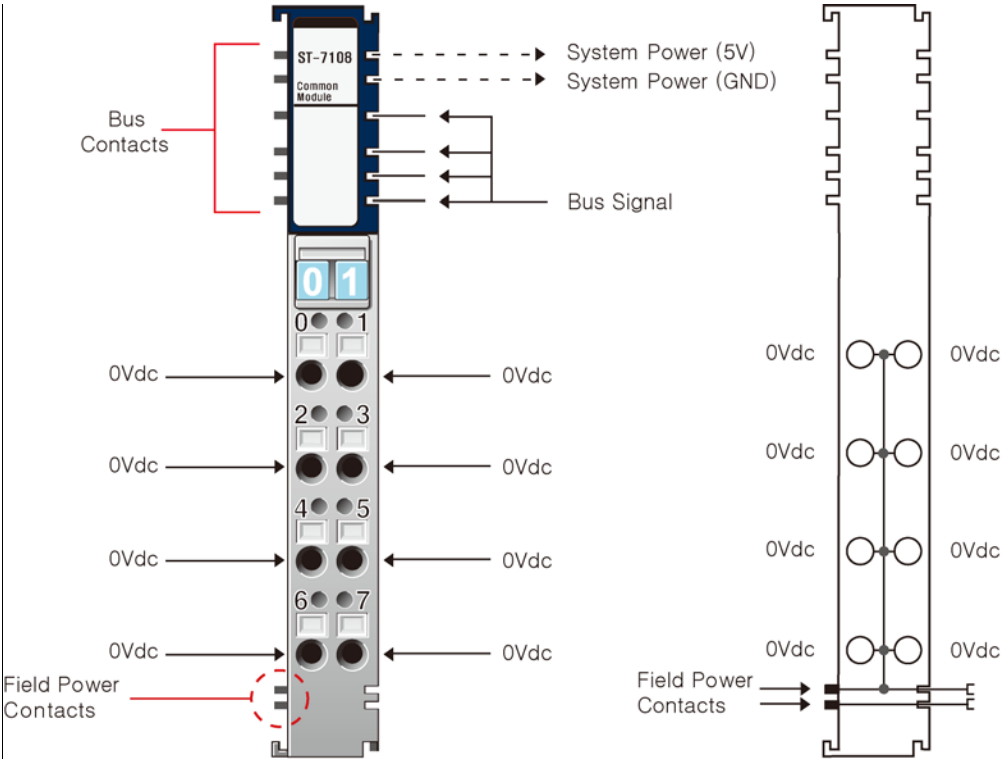

Figure 3: Power Modules: ST-7108

The following table lists the pin numbers and description for ST-7108.

Table 4: ST-7108: Pin Description

Pin Number	Description	Pin Number	Description
0	0Vdc	1	0Vdc
2	0Vdc	3	0Vdc
4	0Vdc	5	0Vdc
6	0Vdc	7	0Vdc

Specification

The following table describes the Input Specifications and the General Specifications for ST-7108.

Table 5: ST-7108: Input and General Specifications

Items	Specification
Input Specification	
Field Power Voltage	0V
Contacts Current	Maximum 10A
Indicators	No Indication
General Specification	
Wiring	I/O Cable Maximum 2.0mm ² (AWG 14)
Weight	65g Maximum
Module Size	12mm x 99mm x 70mm
Environment Condition	See "Environmental Specifications" in Appendix A.

Example

If you have a setup where an external device near the RSTi module needs a ground (0V), you can simply use the ST-7108 as a common module.

The ST-7108 provides 0V.

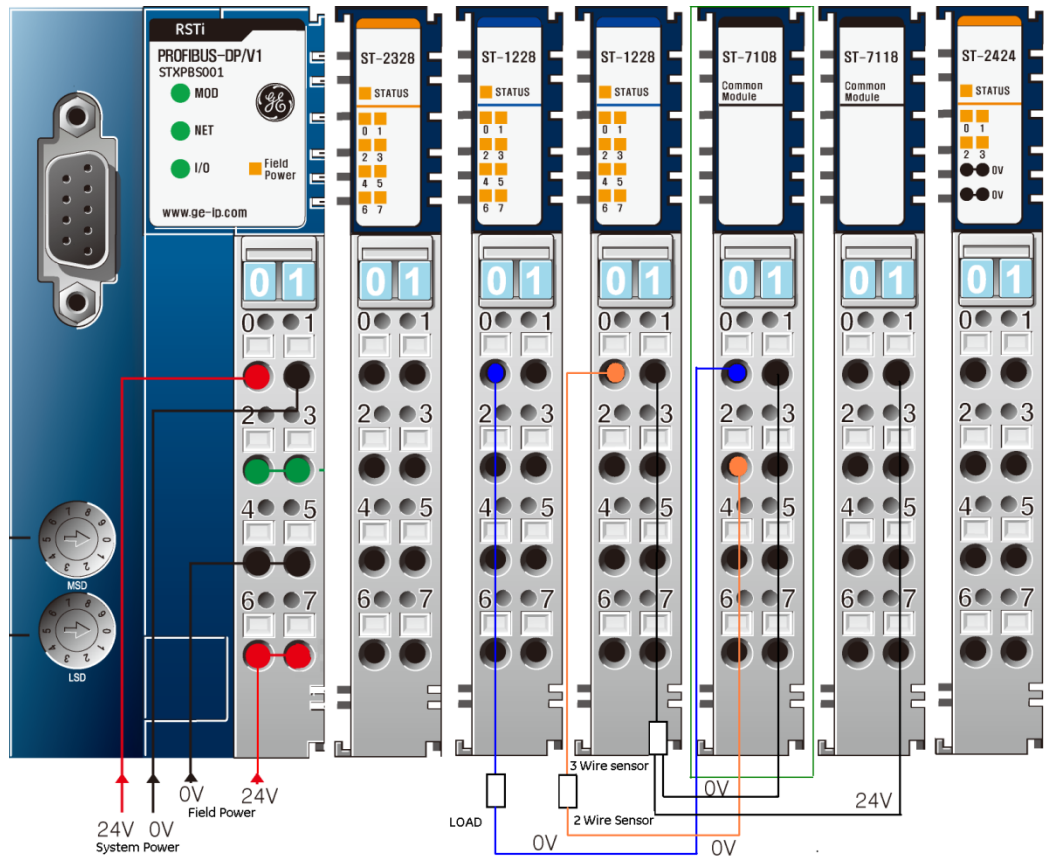

Figure 4: Example: ST-7108

ST-7111

Interface and Data

The following illustration shows the interface design for ST-7111.

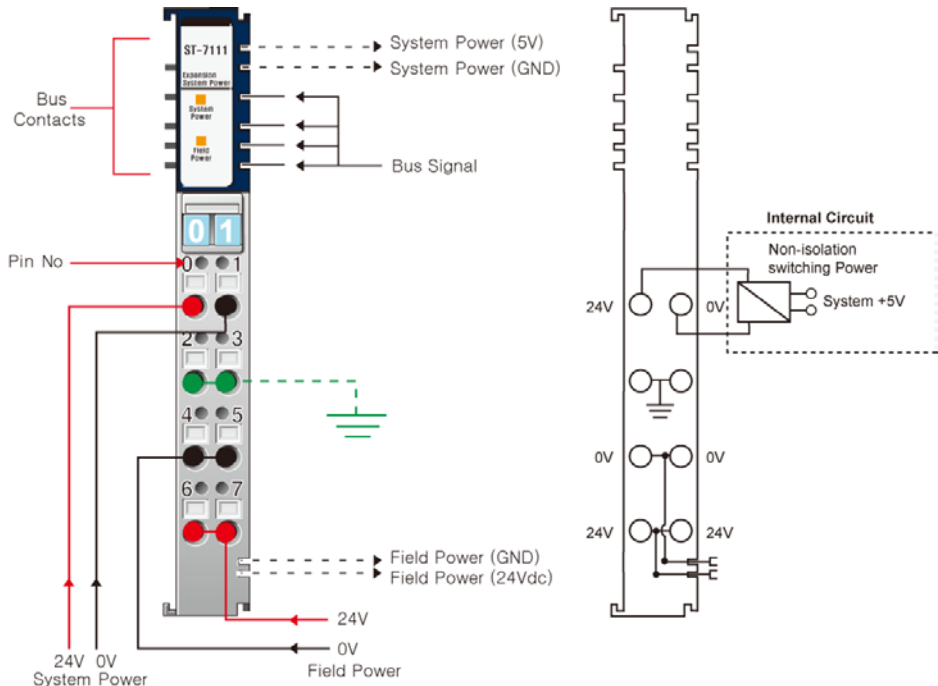

Figure 5: Power Modules: ST-7111

The following table lists the pin numbers and description for ST-7111.

Table 6: ST-7111: Pin Description

Pin Number	Description	Pin Number	Description
0	System Power (+24V)	1	System Power (+0V)
2	Field Ground	3	Field Ground
4	Field Power (+0V)	5	Field Power (+0V)
6	Field Power (+24V)	7	Field Power (+24V)

Specification

The following table describes the Input Specifications and the General Specifications for ST-7111.

Table 7: ST-7111: Input and General Specifications

<i>Items</i>	<i>Specification</i>
Input Specification	
System Input Voltage range	11Vdc to 28.8Vdc
System Power Input Voltage	Normal 24Vdc
Field Power Input Voltage	Normal 24Vdc (±20%)
RSTi Bus Output Voltage	Maximum 5Vdc, 1A
Field Power Contacts Current	Maximum 10A
Indicators	2 Green Input state
General Specification	
Wiring	I/O Cable Maximum 2.0mm ² (AWG 14)
Weight	70g Maximum
Module Size	12mm x 99mm x 70mm
Environment Condition	See "Environmental Specifications" in Appendix A.

Example

When you are using an RSTi setup that requires more than 1.5A for system power (+5v) or 10A of field power, you will need to add a ST-7111 expansion power module to ensure that enough power will be available to all the ST Modules.

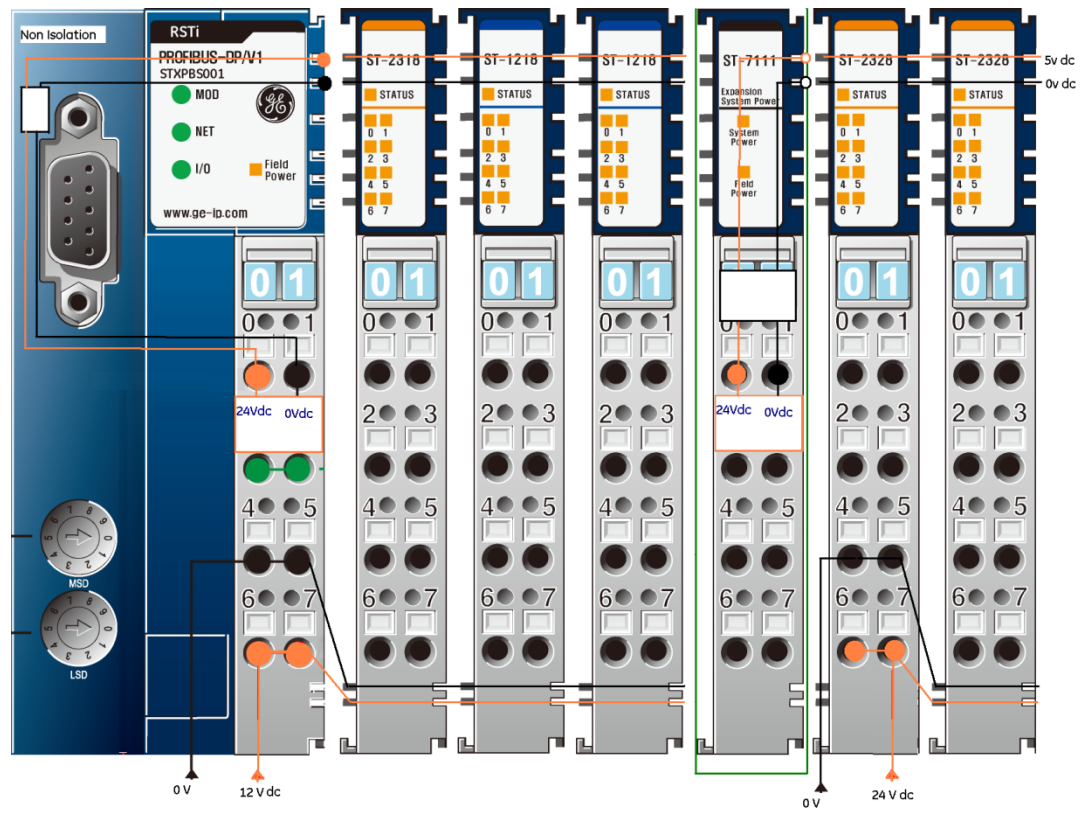

Figure 6: Example: ST-7111

ST-7118

Interface and Data

The following illustration shows the interface design for ST-7118.

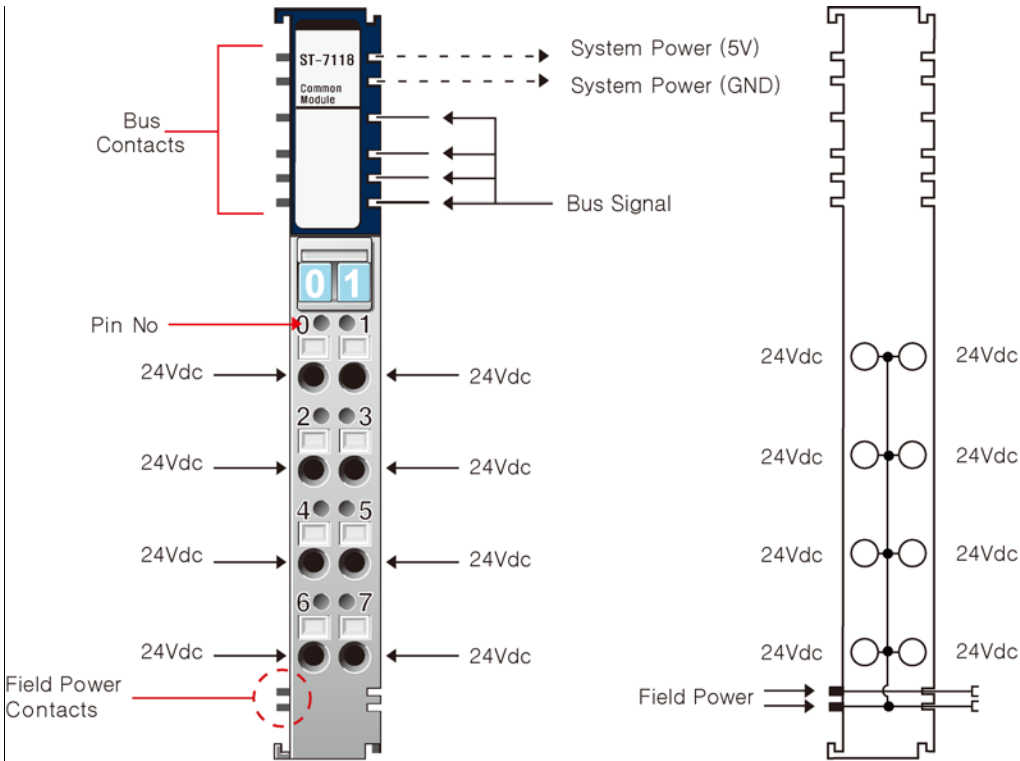

Figure 7: Power Modules: ST-7118

The following table lists the pin numbers and description for ST-7118.

Table 8: ST-7118: Pin Description

Pin Number	Description	Pin Number	Description
0	24Vdc	1	24Vdc
2	24Vdc	3	24Vdc
4	24Vdc	5	24Vdc
6	24Vdc	7	24Vdc

Specification

The following table describes the Input Specifications and the General Specifications for ST-7118.

Table 9: ST-7118: Input and General Specifications

Items	Specification
Input Specification	
Field Power Voltage	24Vdc
Contacts Current	Maximum10A
Indicators	No Indication
General Specification	
Wiring	I/O Cable Maximum 2.0mm.(AWG 14)
Weight	65g Maximum
Module Size	12mm x 99mm x 70mm
Environment Condition	See "Environmental Specifications" in Appendix A.

Example

If you have a setup where an external device near the RSTi module needs 24Vdc of power, you can simply use the ST-7118 as a common module.

The ST-7118 provides 24Vdc of power.

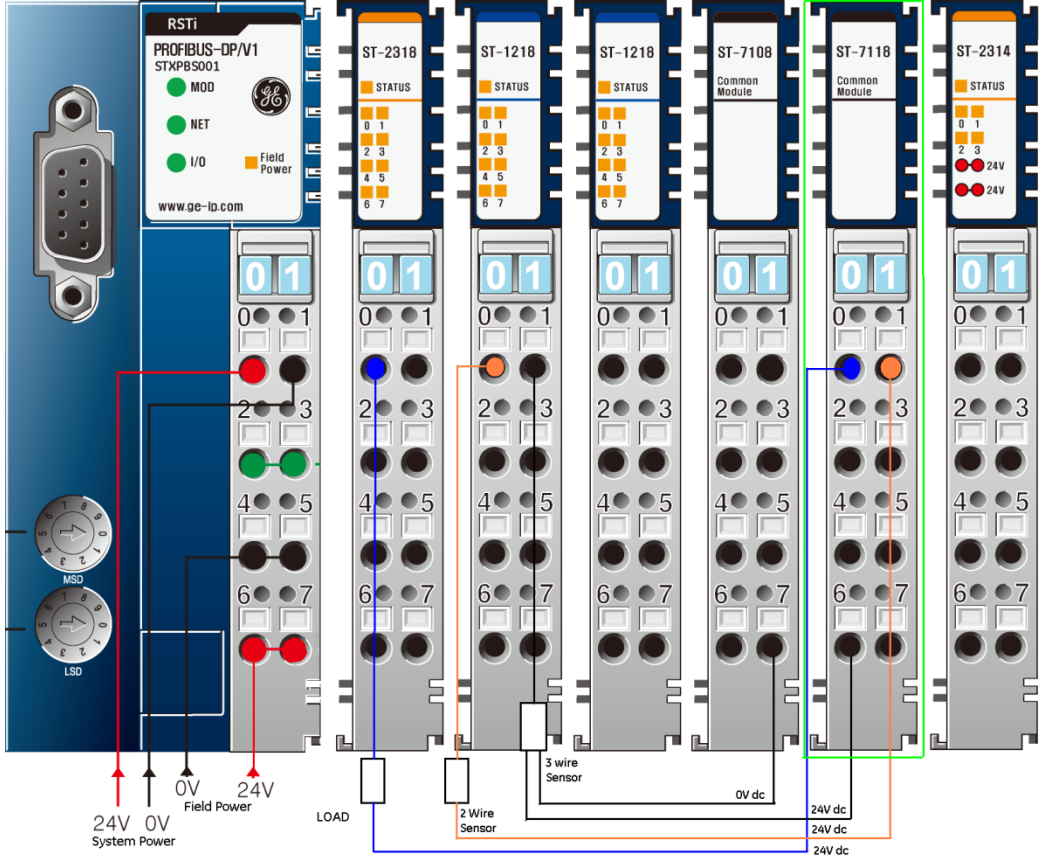

Figure 8: Example: ST-7118

ST-7188

Interface and Data

The following illustration shows the interface design for ST-7188.

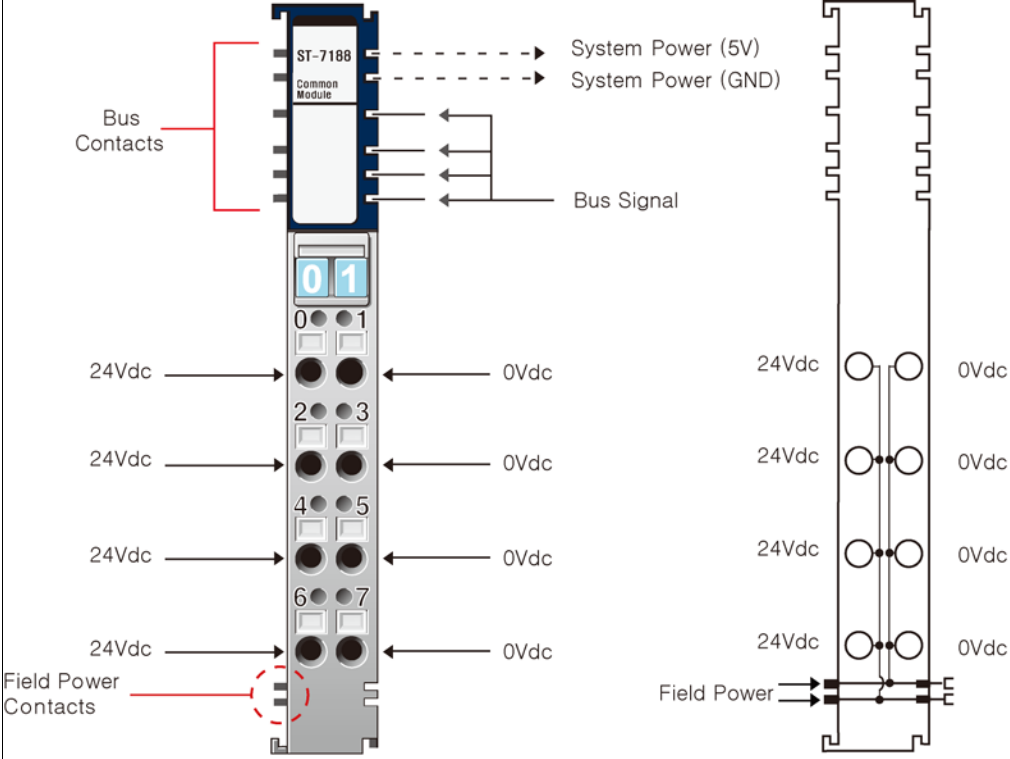

Figure 9: Power Modules: ST-7188

The following table lists the pin numbers and description for ST-7188.

Table 10: ST-7188: Pin Description

<i>Pin Number</i>	<i>Description</i>	<i>Pin Number</i>	<i>Description</i>
0	24Vdc	1	0Vdc
2	24Vdc	3	0Vdc
4	24Vdc	5	0Vdc
6	24Vdc	7	0Vdc

Specification

The following table describes the Input Specifications and the General Specifications for ST-7188.

Table 11: ST-7188: Input and General Specifications

Items	Specification
Input Specification	
Field Power Voltage	24Vdc, 0Vdc
Contacts Current	Maximum 10A
Indicators	No Indication
RSTi Bus Power Contactor	Yes
General Specification	
Power Dissipation	Expansion Power Distributor
Wiring	I/O Cable Maximum 2.0mm ² (AWG 14)
Weight	65g Maximum
Module Size	12mm x 99mm x 70mm
Environment Condition	See "Environmental Specifications" in Appendix A.

ST-7241

Interface and Data

The following illustration shows the interface design for ST-7241.

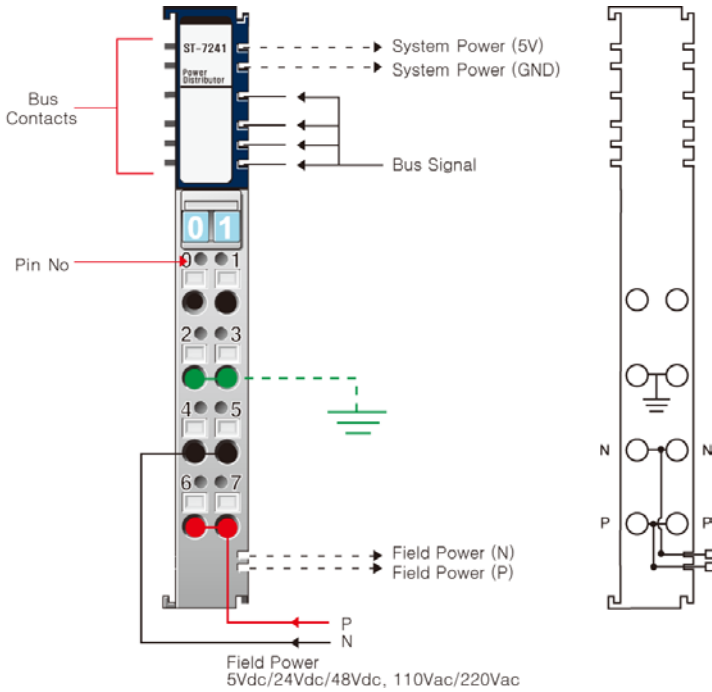

Figure 10: Power Modules: ST-7241

The following table lists the pin numbers and description for ST-7241.

Table 12: ST-7241: Pin Description

<i>Pin Number</i>	<i>Description</i>	<i>Pin Number</i>	<i>Description</i>
0	No Connection	1	No Connection
2	Field Ground	3	Field Ground
4	Field Power arbitrary (N)	5	Field Power arbitrary (N)
6	Field Power arbitrary (P)	7	Field Power arbitrary (P)

Specification

The following table describes the Input Specifications and the General Specifications for ST-7241.

Table 13: ST-7241: Input and General Specifications

Items	Specification
Input Specification	
Field Power Voltage	Arbitrary
Field Power Contacts Current	Maximum 10A
Indicators	No Indication
General Specification	
Wiring	I/O Cable Maximum 2.0mm ² (AWG 14)
Weight	70g Maximum
Module Size	12mm x 99mm x 70mm
Environment Condition	See "Environmental Specifications" in Appendix A.

Example

When you have a RSTi setup and need to use different Field Power Voltage, you can use the ST-7241 to change the distributed Voltage from 5Vdc/12Vdc/24Vdc /48Vdc, or from 110Vac/240Vac as below:

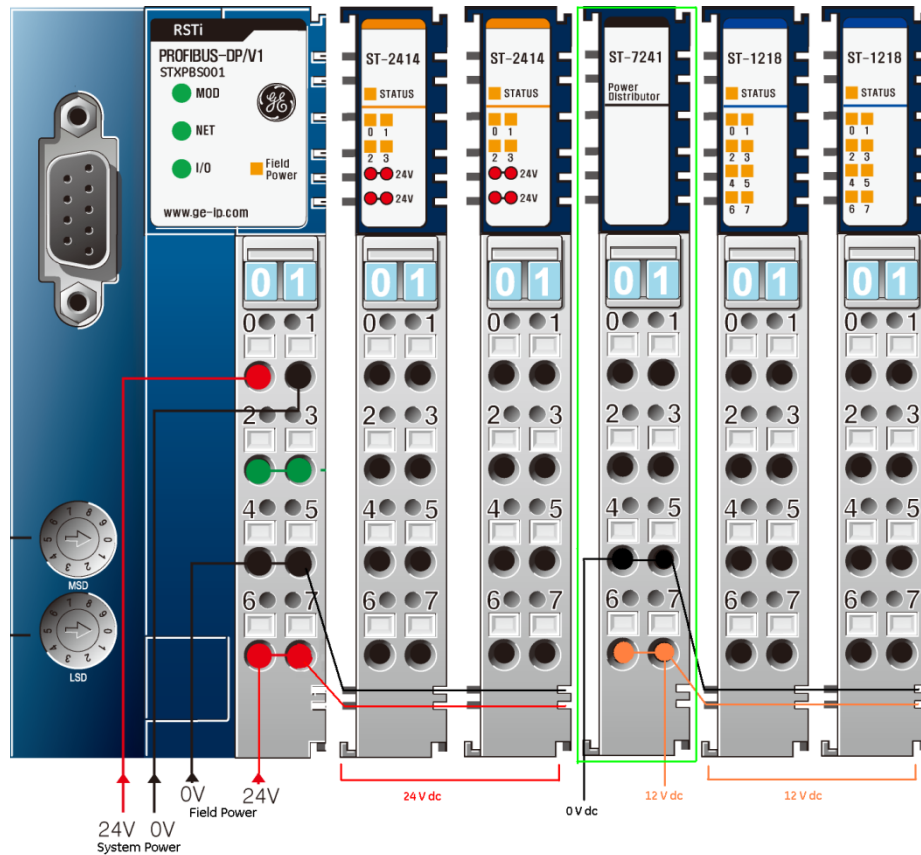

Figure 11: Example: ST-7241

ST-7408

Interface and Data

The following illustration shows the interface design for ST-7408.

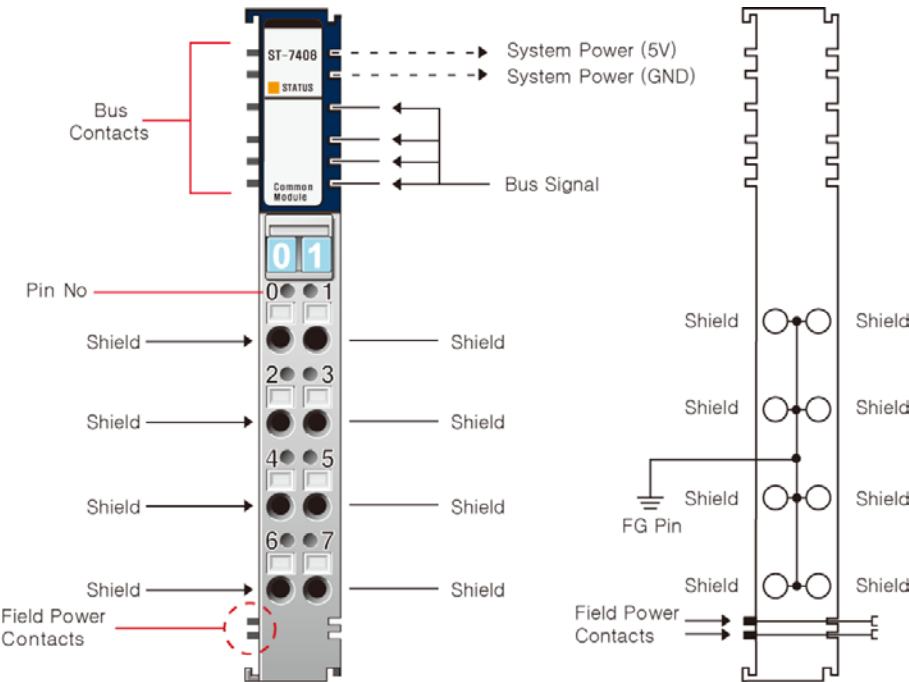

Figure 12: Power Modules: ST-7408

The following table lists the pin numbers and description for ST-7408.

Table 14: ST-7408: Pin Description

Pin Number	Description	Pin Number	Description
0	Shield	1	Shield
2	Shield	3	Shield
4	Shield	5	Shield
6	Shield	7	Shield

Specification

The following table describes the Input Specifications and the General Specifications for ST-7408.

Table 15: ST-7408: Input and General Specifications

Items	Specification
Input Specification	
Field Power Voltage	Shield
Indicators	1 Green/Red LED, Module Status
Field Power Contacts Current	Maximum 10A
RSTi Bus Power Contactor	Yes
General Specification	
Power Dissipation	Maximum 18mA @5Vdc
Wiring	I/O Cable Maximum 2.0mm ² (AWG 14)
Weight	70g Maximum
Module Size	12mm x 99mm x 70mm
Environment Condition	See "Environmental Specifications" in Appendix A.

Example

The ST-7408 Provides Shield.

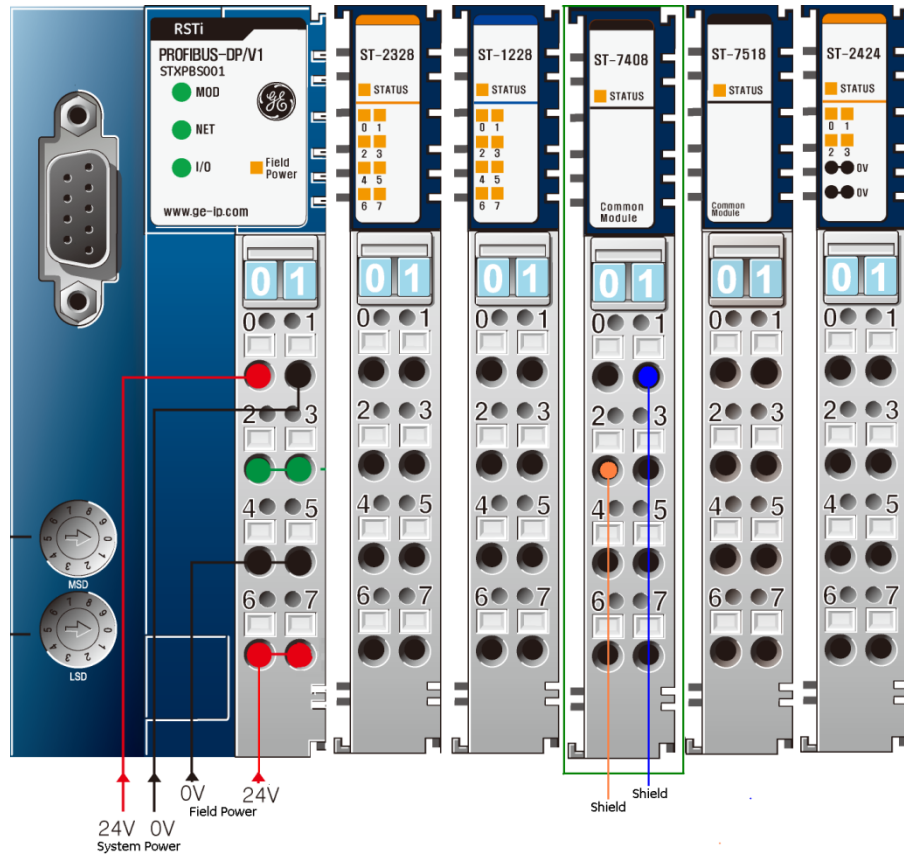

Figure 13: Example: ST-7408

ST-7508

Interface and Data

The following illustration shows the interface design for ST-7508.

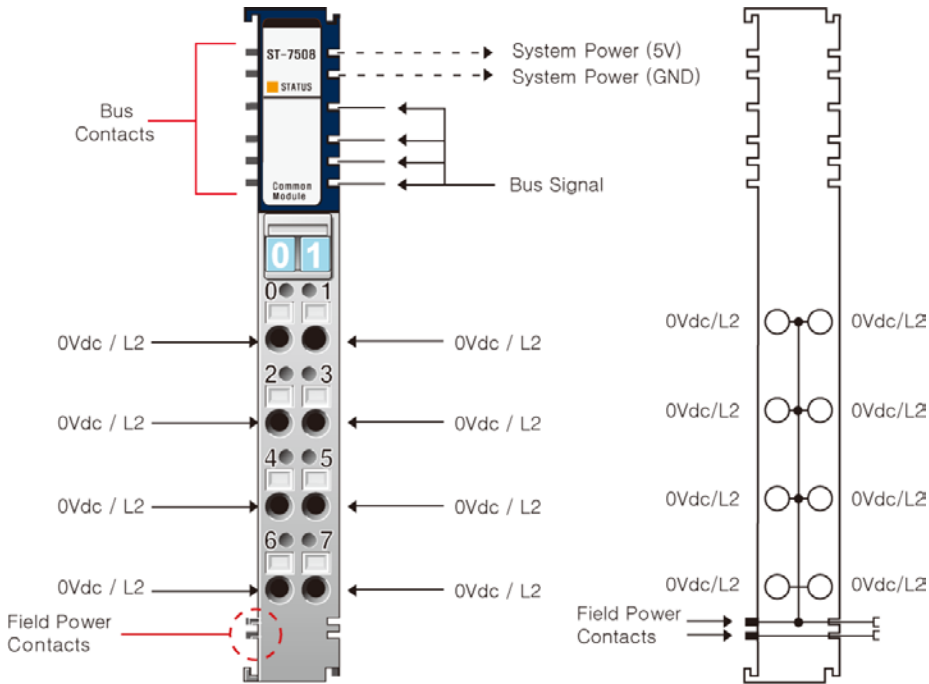

Figure 14: Power Modules: ST-7508

The following table lists the pin numbers and description for ST-7508.

Table 16: ST-7508: Pin Description

Pin Number	Description	Pin Number	Description
0	0Vdc/L2	1	0Vdc/L2
2	0Vdc/L2	3	0Vdc/L2
4	0Vdc/L2	5	0Vdc/L2
6	0Vdc/L2	7	0Vdc/L2

Specification

The following table describes the Input Specifications and the General Specifications for ST-7508.

Table 17: ST-7508: Input and General Specifications

Items	Specification
Input Specification	
Field Power Voltage	0Vdc
Indicators	1 Green/Red LED, Module Status
Field power Contacts Current	Maximum 10A
RSTi Bus Power Contactor	Yes
General Specification	
Power Dissipation	Maximum 18mA @5Vdc
Wiring	I/O Cable Maximum 2.0mm ² (AWG 14)
Weight	65g Maximum
Module Size	12mm x 99mm x 70mm
Environment Condition	See "Environmental Specifications" in Appendix A.

Example

If you have a setup where an external device near the RSTi module needs a ground (0V), you can simply use the ST-7508 as a common module.

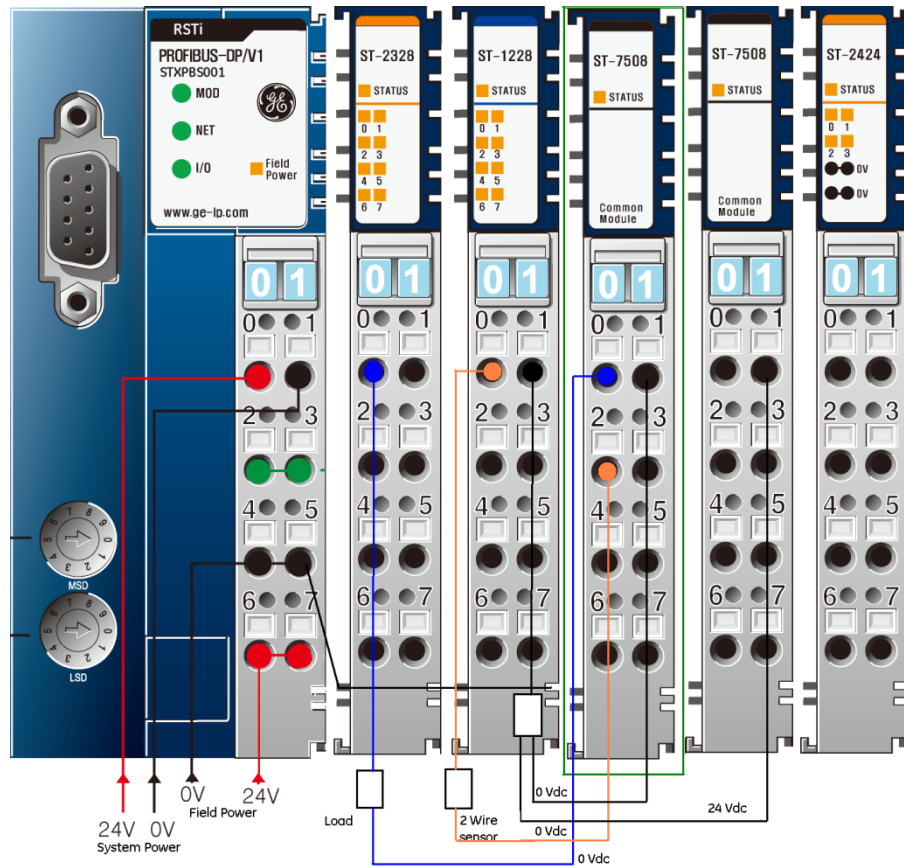

Figure 15: Example: ST-7508

ST-7511

Interface and Data

The following illustration shows the interface design for ST-7511.

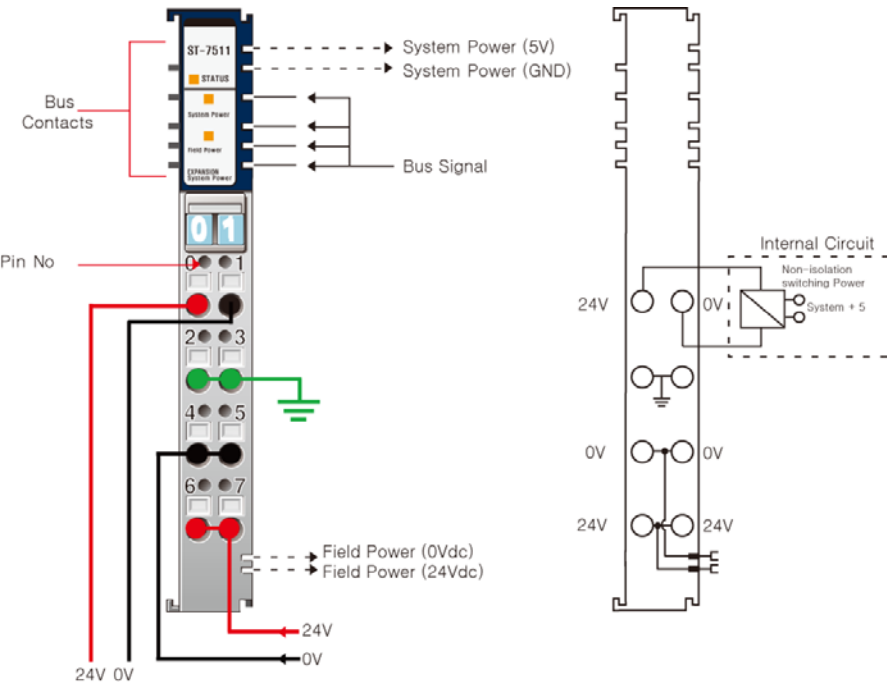

Figure 16: Power Modules: ST-7511

The following table lists the pin numbers and description for ST-7511.

Table 18: ST-7511: Pin Description

Pin Number	Description	Pin Number	Description
0	System Power (+24Vdc)	1	System Power (0V)
2	Field Ground	3	Field Ground
4	Field Ground (0V)	5	Field Ground (0V)
6	Field Ground (+24Vdc)	7	Field Ground (+24Vdc)

Specification

The following table describes the Input Specifications and the General Specifications for ST-7511.

Table 19: ST-7511: Input and General Specifications

Items	Specification
Input Specification	
System Input Voltage range	11Vdc to 28.8Vdc
System Power Input Voltage	Normal 24Vdc
Indicators	1 Green/Red LED, Module Status / 2Green LED, Input Status
Field Power Input Voltage	Normal 24Vdc (±20%)
Field Power Contacts Current	Maximum 10A
RSTi Bus Output Voltage	Maximum 5Vdc, 1A
General Specification	
Power Dissipation	Maximum 14mA @ 5Vdc
Wiring	I/O Cable Maximum 2.0mm ² (AWG 14)
Weight	70g Maximum
Module Size	12mm x 99mm x 70mm
Environment Condition	See "Environmental Specifications" in Appendix A.

Example

When you are using a RSTi setup that requires more than 1.5A for system power (+5v) or 10A of field power, you will need to add a ST-7511 expansion power module to ensure that enough power will be available to all the ST Modules.

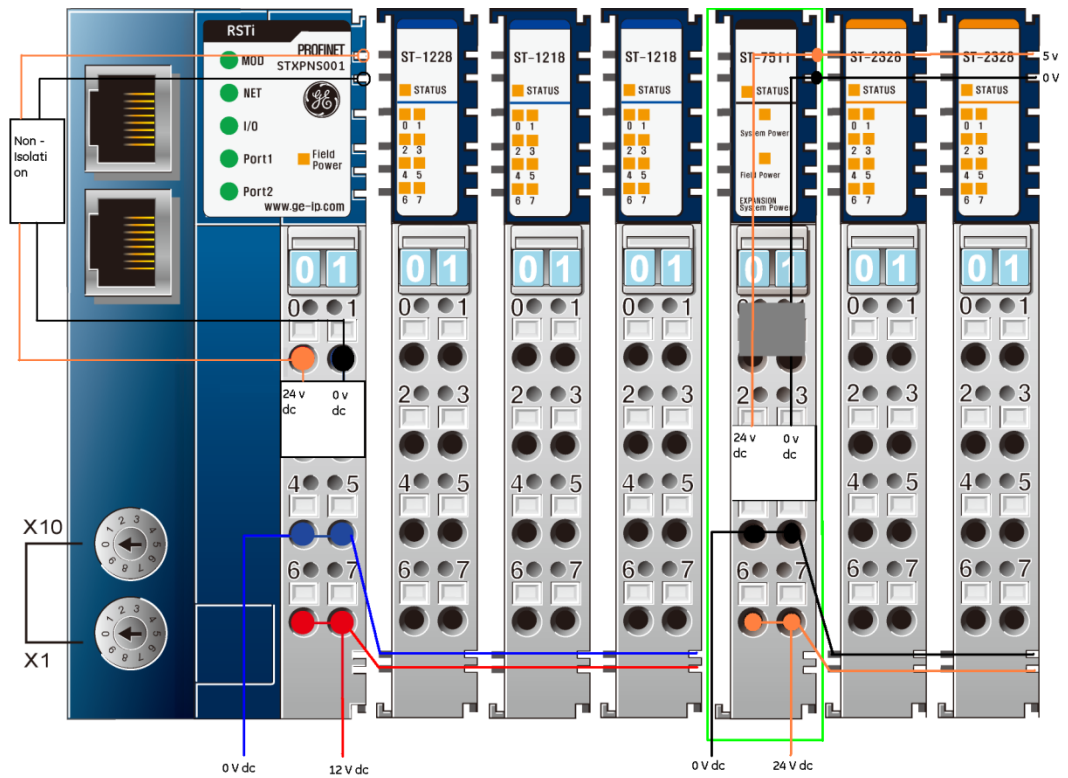

Figure 17: Example: ST-7511

ST-7518

Interface and Data

The following illustration shows the interface design for ST-7518.

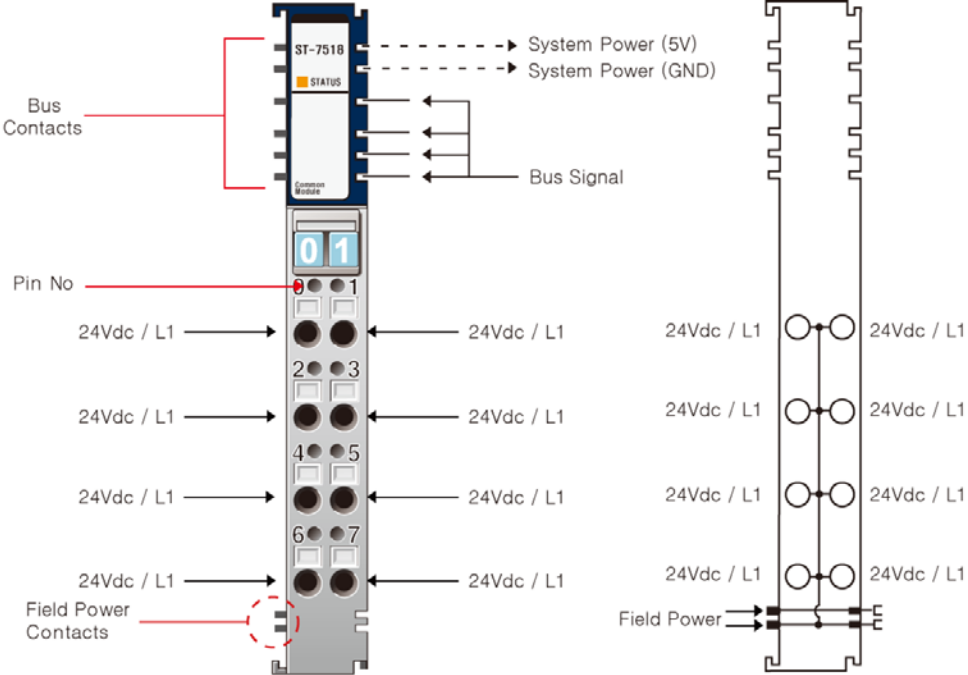

Figure 18: Power Modules: ST-7518

The following table lists the pin numbers and description for ST-7518.

Table 20: ST-7518: Pin Description

Pin Number	Description	Pin Number	Description
0	24Vdc/L1	1	24Vdc/L1
2	24Vdc/L1	3	24Vdc/L1
4	24Vdc/L1	5	24Vdc/L1
6	24Vdc/L1	7	24Vdc/L1

Specification

The following table describes the Input Specifications and the General Specifications for ST-7518.

Table 21: ST-7518: Input and General Specifications

Items	Specification
Input Specification	
Field Power Voltage	24Vdc
Indicators	1 Green/Red LED, Module Status
Field Power Contacts Current	Maximum 10A
General Specification	
Power Dissipation	Maximum 18mA @ 5Vdc
Wiring	I/O Cable Maximum 2.0mm ² (AWG 14)
Weight	64g Maximum
Module Size	12mm x 99mm x 70mm
Environment Condition	See "Environmental Specifications" in Appendix A.

Example

If you have a setup where an external device near the RSTi module needs 24Vdc of power, you can simply use the ST-7518 as a common module.

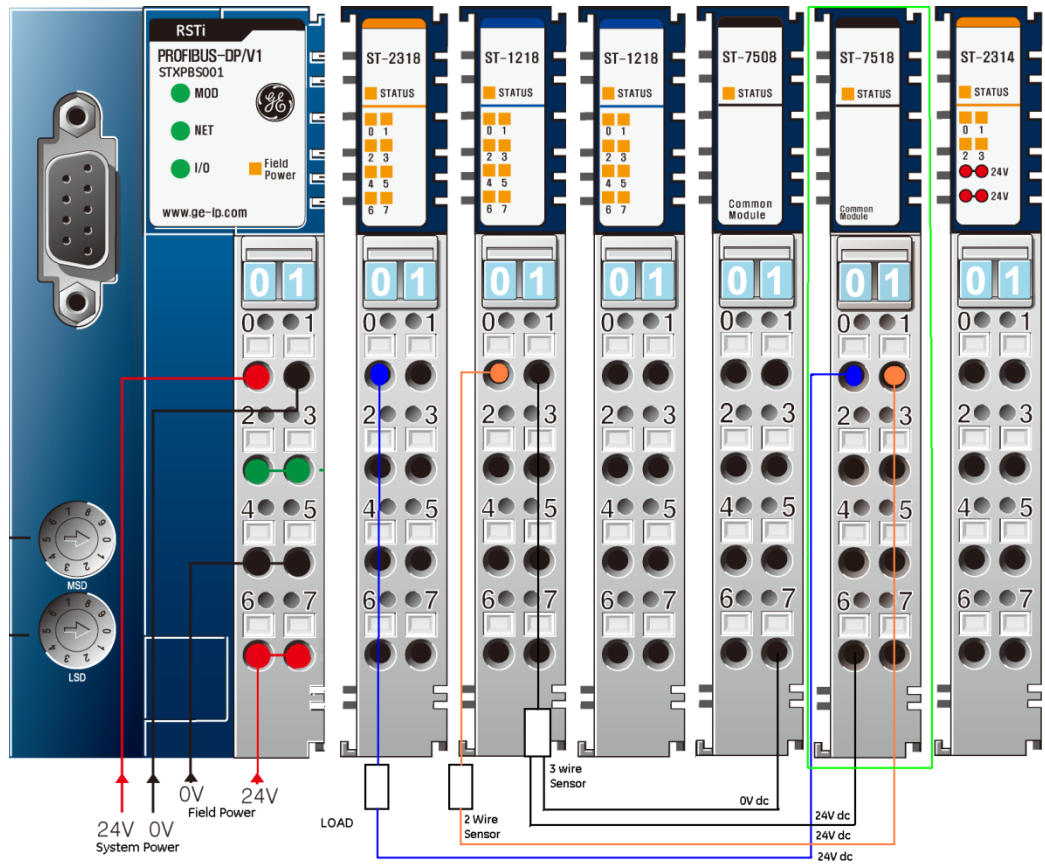

Figure 19: Example: ST-7518

ST-7588

Interface and Data

The following illustration shows the interface design for ST-7588.

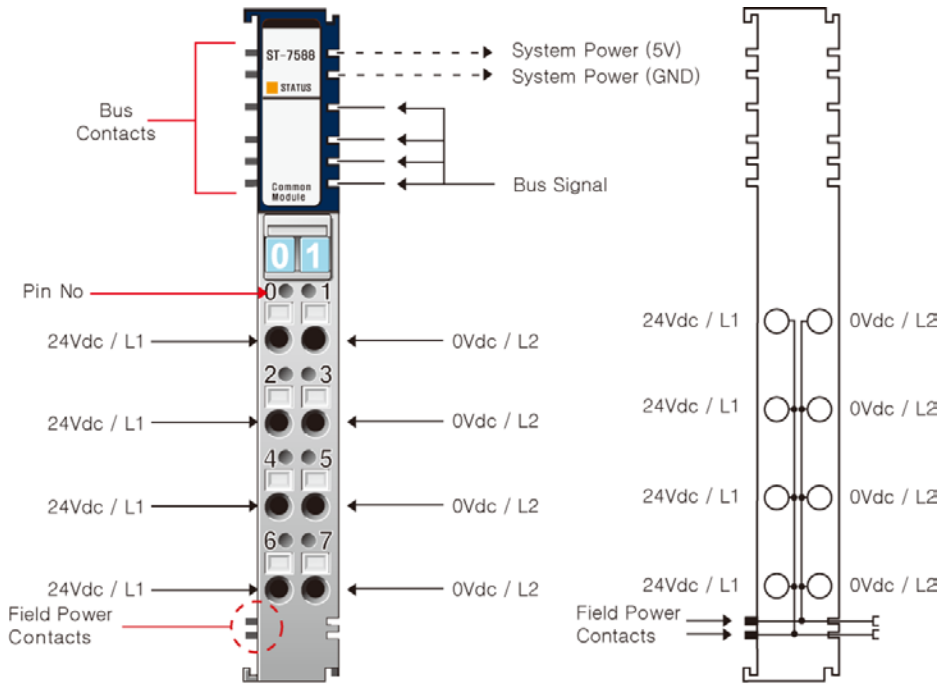

Figure 20: Power Modules: ST-7588

The following table lists the pin numbers and description for ST-7588.

Table 22: ST-7588: Pin Description

Pin Number	Description	Pin Number	Description
0	24Vdc/L1	1	0Vdc/L2
2	24Vdc/L1	3	0Vdc/L2
4	24Vdc/L1	5	0Vdc/L2
6	24Vdc/L1	7	0Vdc/L2

Specification

The following table describes the Input Specifications and the General Specifications for ST-7588.

Table 23: ST-7588: Input and General Specifications

Items	Specification
Input Specification	
Field Power Voltage	24Vdc, 0Vdc
Indicators	1 Green/Red LED, Module Status
Field Power Contacts Current	Maximum 10A
General Specification	
Power Dissipation	Maximum 18mA @ 5Vdc
Wiring	I/O Cable Maximum 2.0mm.(AWG 14)
Weight	65g Maximum
Module Size	12mm x 99mm x 70mm
Environment Condition	See "Environmental Specifications" in Appendix A.

Example

If you have a setup where an external device near the RSTi module needs 24Vdc of power, you can simply use the ST-7588 as a common module.

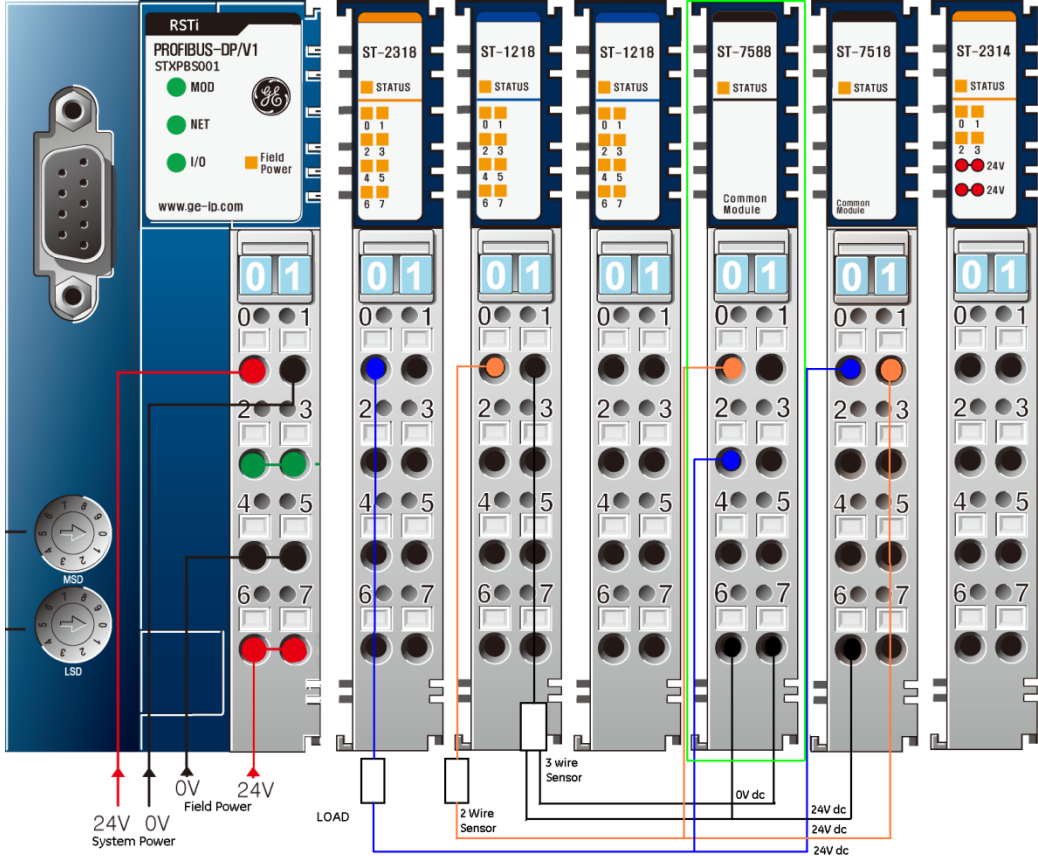

Figure 21: Example: ST-7588

ST-7641

Interface and Data

The following illustration shows the interface design for ST-7641.

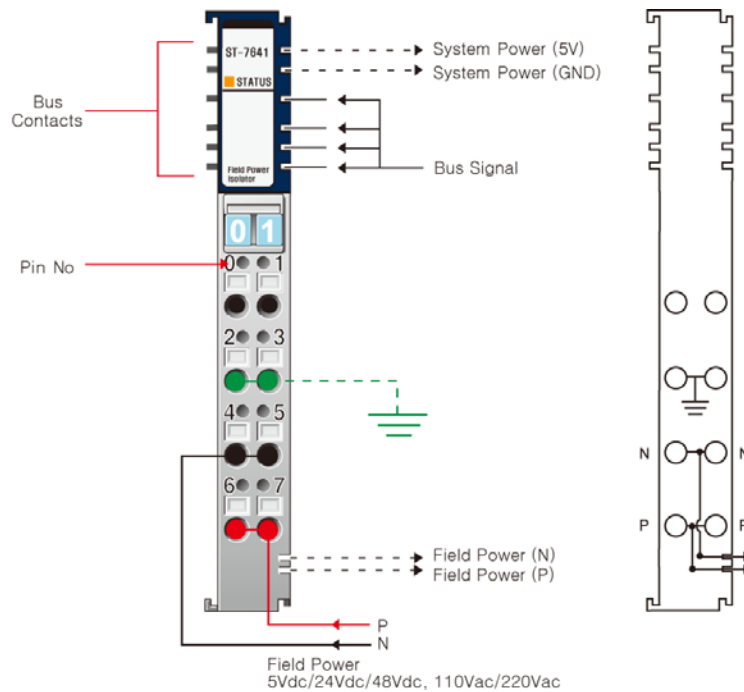

Figure 22: Power Modules: ST-7641

The following table lists the pin numbers and description for ST-7641.

Table 24: ST-7641: Pin Description

Pin Number	Description	Pin Number	Description
0	No Connector	1	No Connector
2	Field Ground	3	Field Ground
4	Field Power arbitrary (N)	5	Field Power arbitrary (N)
6	Field Power arbitrary (P)	7	Field Power arbitrary (P)

Specification

The following table describes the Input Specifications and the General Specifications for ST-7641.

Table 25: ST-7641: Input and General Specifications

Items	Specification
Input Specification	
Field Power Voltage	Arbitrary
Indicators	1 Green/Red LED, Module Status
Field Power Contacts Current	Maximum10A
General Specification	
Power Dissipation	Maximum 18mA @ 5Vdc
Wiring	I/O to Field Power: Non-Isolation
Weight	70g Maximum
Module Size	12mm x 99mm x 70mm
Environment Condition	See "Environmental Specifications" in Appendix A.

Example

When you have a RSTi setup and need to use different Field Power Voltage, you can use the ST-7641 to change the isolated Voltage form 5Vdc, 12Vdc to 24Vdc to 48Vdc, or from 110Vac, 240Vac as below:

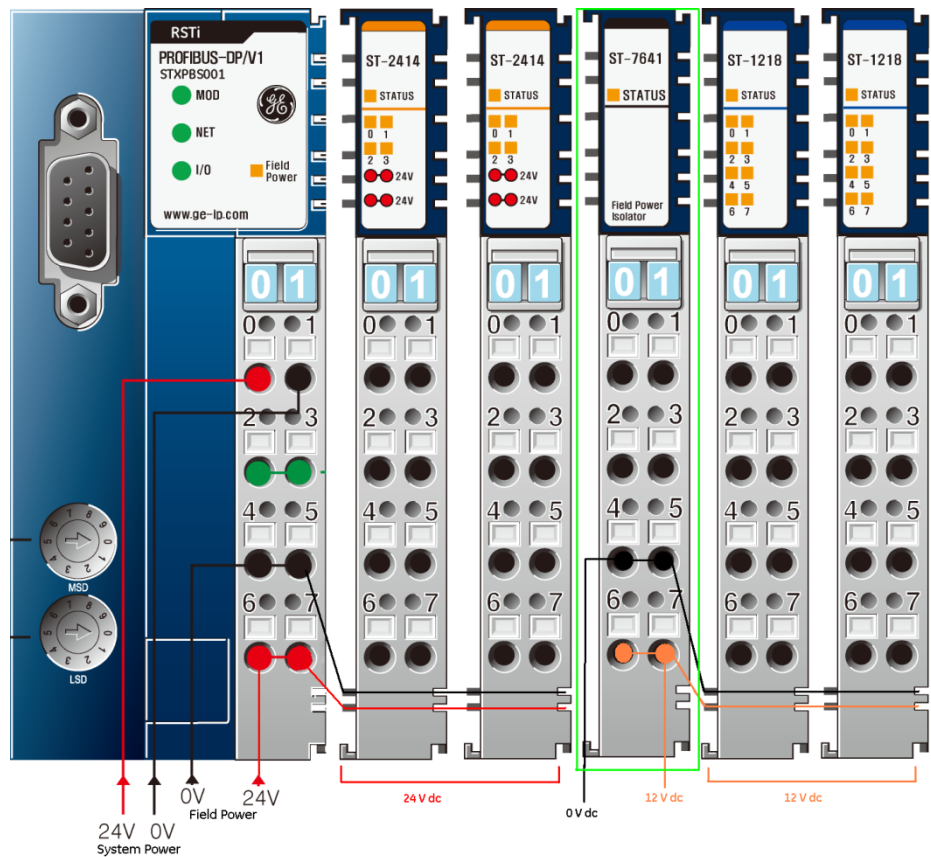

Figure 23: Example: ST-7641

Dimension

ST-7xxx

The following illustration shows the dimensions for ST-7xxx series.

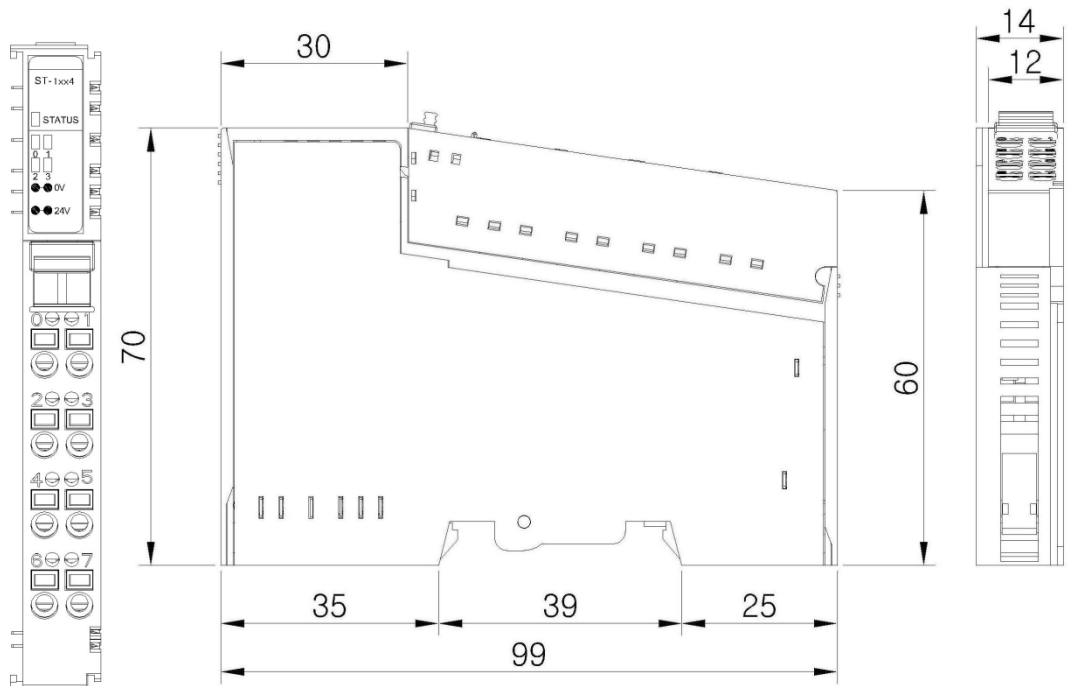

Figure 24: ST-7xxx Dimension

Diagnostics

Normal Module

The LEDs indicate the status of the power modules. The table below shows the corresponding functions of LEDs during normal operation. You can use this table as a reference for troubleshooting errors.

Table 26: Normal Module

Color	Status	Function
OFF	Not Power Not Initialized	Device has no IO Module or may not be powered The Parameter is not initialized yet.
Solid Green	RSTi Bus Connection	RSTi Bus Normal Operation
Flashing Green	RSTi Bus Ready	RSTi Bus Ready
Flashing Red	RSTi Bus Fault	RSTi Bus Failed Communication
Solid Red	Device Fault	Device fault

Note: For more help on troubleshooting errors related to Network Adaptor and its protocols, please refer to Network Adaptor User Manual.

Discrete input modules range from DC 5V, DC 24V, DC 48V, AC 110V up to AC 240V.
Each part is available with 4 to 16 points.

ST-1114

Interface and Data

The following illustration shows the interface design for ST-1114.

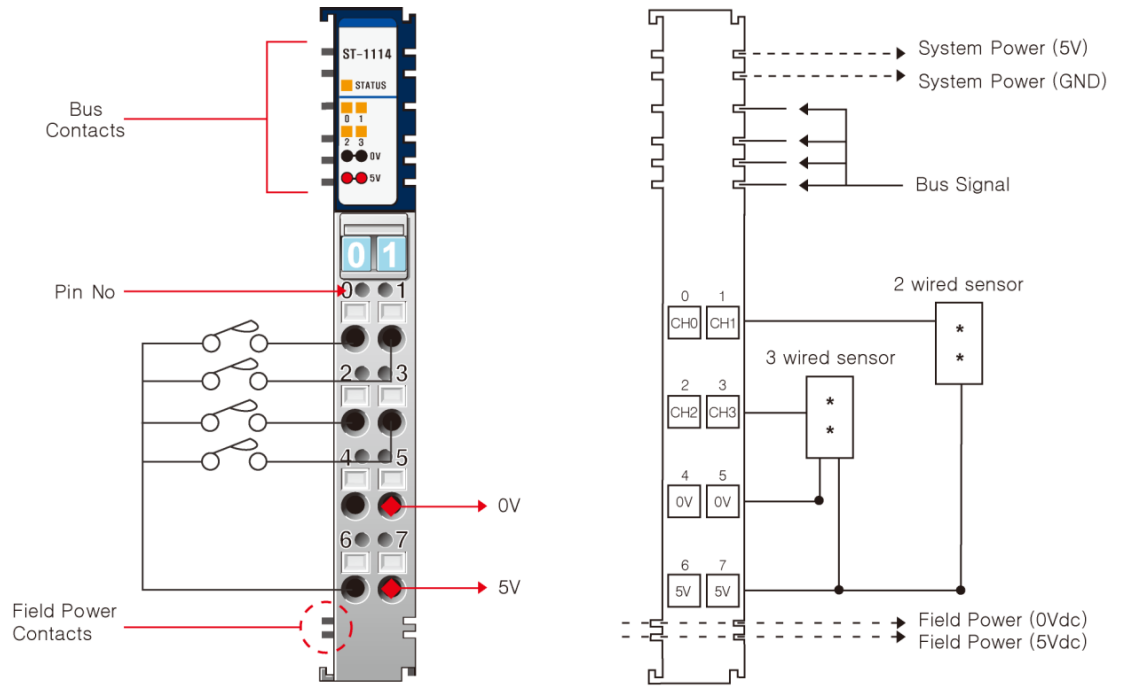

Figure 25: Discrete Input Module: ST-1114

The following table lists the pin numbers and description for ST-1114.

Table 27: ST-1114: Pin Description

<i>Pin Number</i>	<i>Description</i>	<i>Pin Number</i>	<i>Description</i>
0	Input Channel 0	1	Input Channel 1
2	Input Channel 2	3	Input Channel 3
4	Field Ground (0V)	5	Field Ground (0V)
6	Field Power (+5Vdc)	7	Field Power (+5Vdc)

Specification

The following table describes the Input Specifications and the General Specifications for ST-1114.

Table 28: ST-1114: Input and General Specifications

Items	Specification
Input Specification	
Inputs Per Module	4 Points, Positive Logic
Indicators	4 Green Input States, 1 Green/Red RSTi Bus State
ON-state Voltage	5Vdc nominal Minimum 2.4Vdc ~ Maximum 5.5Vdc
Minimum OFF-state Voltage	Maximum 0.8Vdc
ON-state Current	Maximum 4.5mA / Point @5.5Vdc
Input Signal Delay	OFF to ON: Maximum 0.5ms ON to OFF: Maximum 0.5ms
Nominal Input Impedance	Typical 1.3KΩ
Filtering Time	Typical 1.5ms (software filtering)
Common Type	4 Points/2COM (Single Common)
General Specification	
Power Dissipation	Maximum 35mA @ 5.0Vdc
Isolation	I/O to Logic: Photo coupler isolation
Field Power	Supply Voltage: 5Vdc nominal Voltage Range: 4.5~5.5Vdc
Wiring	I/O Cable Maximum 2.0mm ² (AWG 14)
Weight	70g
Module Size	12mm x 99mm x 70mm
Environment Condition	See "Environmental Specifications" in Appendix A.

ST-1124

Interface and Data

The following illustration shows the interface design for ST-1124.

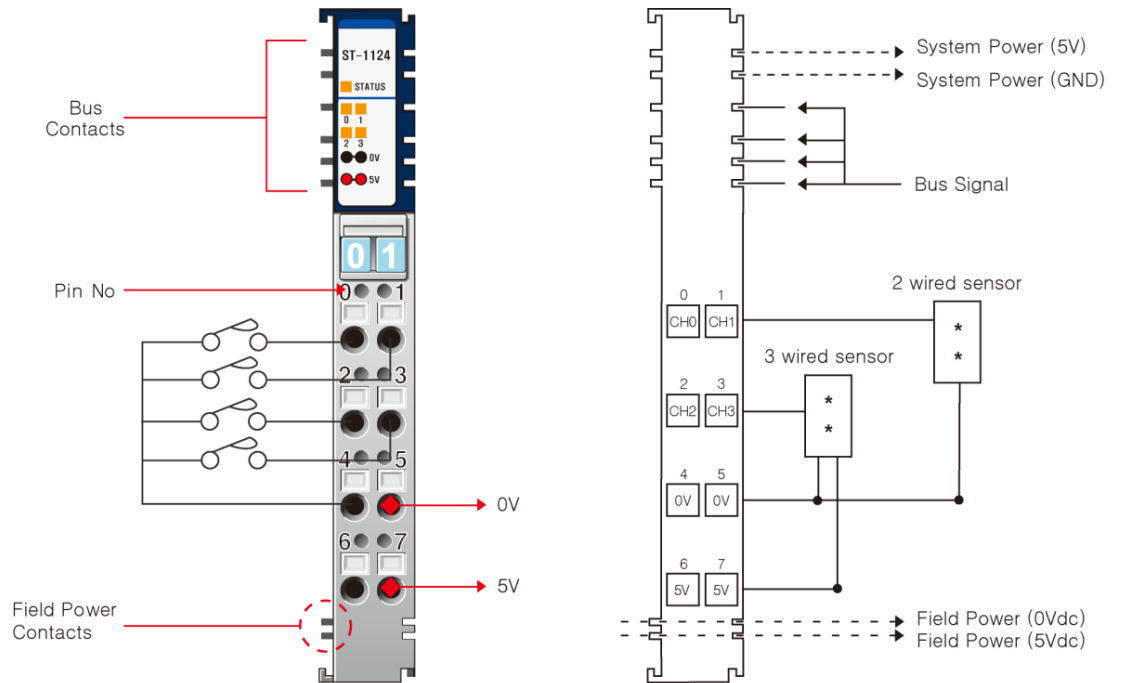

Figure 26: Discrete Input Module: ST-1124

The following table lists the pin numbers and description for ST-1124.

Table 29: ST-1124: Pin Description

<i>Pin Number</i>	<i>Description</i>	<i>Pin Number</i>	<i>Description</i>
0	Input Channel 0	1	Input Channel 1
2	Input Channel 2	3	Input Channel 3
4	Field Ground (0V)	5	Field Ground (0V)
6	Field Power (+5Vdc)	7	Field Power (+5Vdc)

Specification

The following table describes the Input Specifications and the General Specifications for ST-1124.

Table 30: ST-1124: Input and General Specifications

Items	Specification
Input Specification	
Inputs Per Module	4 Points, Negative Logic
Indicators	4 Green Input States, 1 Green/Red RSTi Bus State
ON-state Voltage	5Vdc nominal Minimum 2.4Vdc ~ Maximum 5.5Vdc
Minimum OFF-state Voltage	Maximum 0.8Vdc
ON-state Current	Maximum 4.5mA/Point @5.5Vdc
Input Signal Delay	OFF to ON: Maximum 0.5ms ON to OFF: Maximum 0.5ms
Nominal Input Impedance	Typical 1.3KΩ
Filtering Time	Typical 1.5ms (software filtering)
Common Type	4 Points/2COM (Single Common)
General Specification	
Power Dissipation	Maximum 35mA @ 5.0Vdc
Isolation	I/O to Logic: Photo coupler isolation
Field Power	Supply Voltage: 5Vdc nominal Voltage Range: 4.5~5.5Vdc
Wiring	I/O Cable Maximum 2.0mm ² (AWG 14)
Weight	70g
Module Size	12mm x 99mm x 70mm
Environment Condition	See "Environmental Specifications" in Appendix A.

ST-1214

Interface and Data

The following illustration shows the interface design for ST-1214.

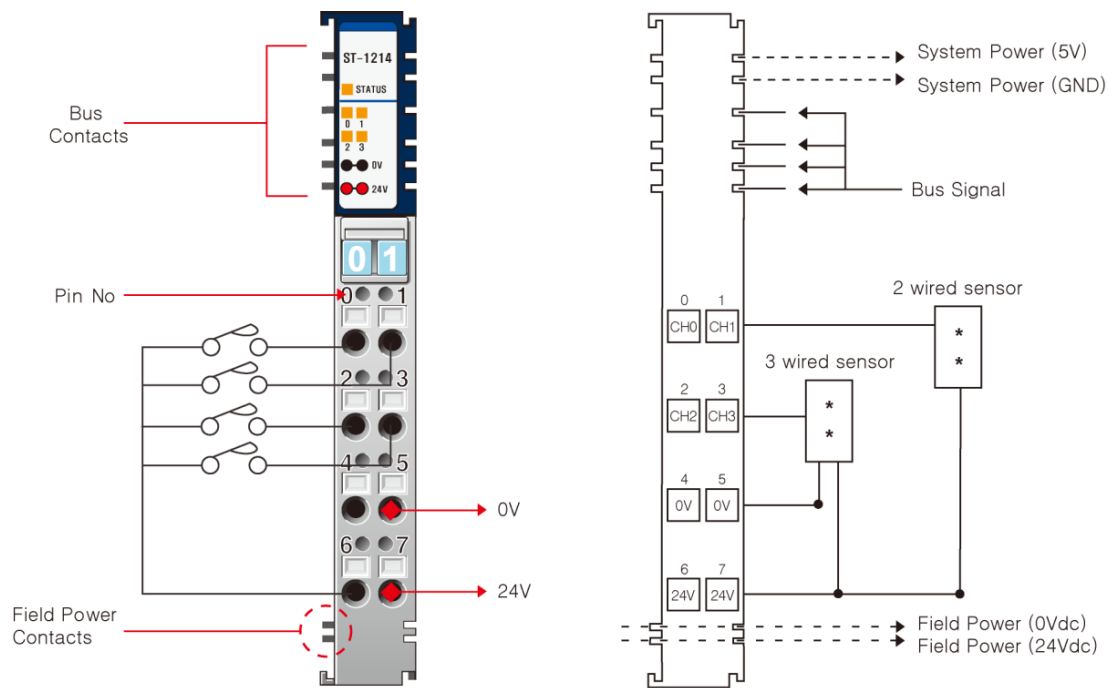

Figure 27: Discrete Input Module: ST-1214

The following table lists the pin numbers and description for ST-1214.

Table 31: ST-1214: Pin Description

<i>Pin Number</i>	<i>Description</i>	<i>Pin Number</i>	<i>Description</i>
0	Input Channel 0	1	Input Channel 1
2	Input Channel 2	3	Input Channel 3
4	Field Ground (0V)	5	Field Ground (0V)
6	Field Power (+24Vdc)	7	Field Power (+24Vdc)

Specification

The following table describes the Input Specifications and the General Specifications for ST-1214.

Table 32: ST-1214: Input and General Specifications

Items	Specification
Input Specification	
Inputs Per Module	4 Points, Positive Logic
Indicators	4 Green Input States, 1 Green/Red RSTi Bus State
ON-state Voltage	24Vdc nominal Minimum 10.2Vdc ~ Maximum 28.8Vdc
Minimum OFF-state Voltage	Maximum 5Vdc
ON-state Current	Maximum 6mA/Point @28.8Vdc
Input Signal Delay	OFF to ON: Maximum 3ms ON to OFF: Maximum 3ms
Nominal Input Impedance	Typical 5.1K Ω
Filtering Time	Typical 1.5ms
Common Type	4 Points/2COM (Single Common)
General Specification	
Power Dissipation	Maximum 35mA @ 5.0Vdc
Isolation	I/O to Logic : Photo coupler isolation
Field Power	Supply Voltage: 24Vdc nominal Voltage Range: 11~28.8Vdc
Wiring	I/O Cable Maximum 2.0mm ² (AWG 14)
Weight	70g
Module Size	12mm x 99mm x 70mm
Environment Condition	See "Environmental Specifications" in Appendix A.

ST-1218

Interface and Data

The following illustration shows the interface design for ST-1218.

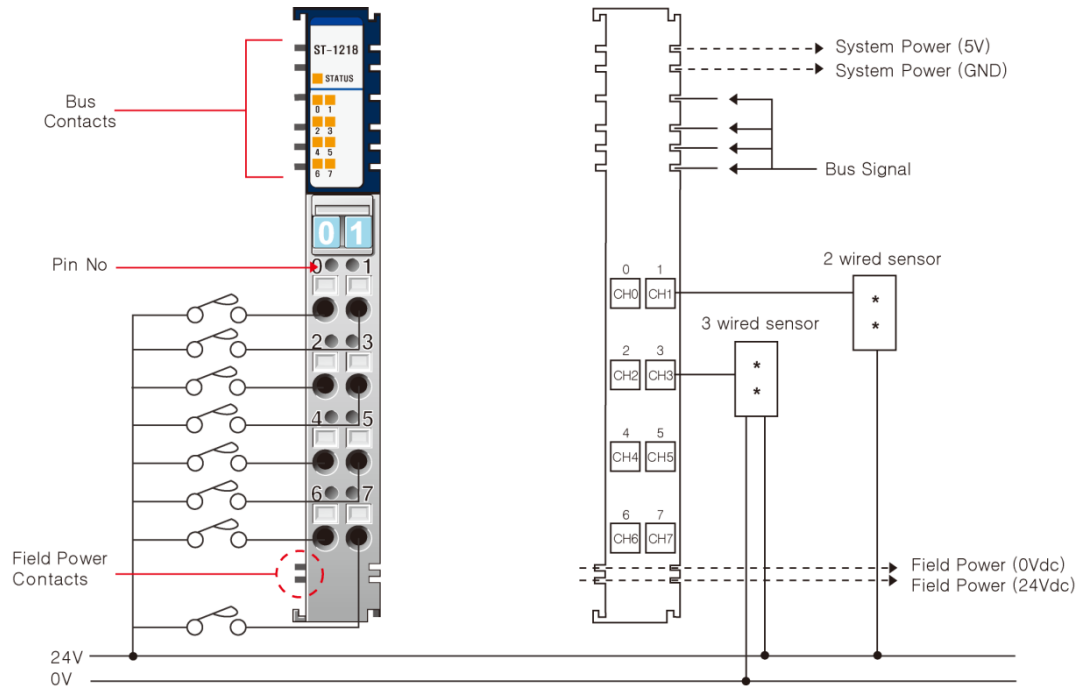

Figure 28: Discrete Input Module: ST-1218

The following table lists the pin numbers and description for ST-1218.

Table 33: ST-1218: Pin Description

Pin Number	Description	Pin Number	Description
0	Input Channel 0	1	Input Channel 1
2	Input Channel 2	3	Input Channel 3
4	Input Channel 4	5	Input Channel 5
6	Input Channel 6	7	Input Channel 7

Specification

The following table describes the Input Specifications and the General Specifications for ST-1218.

Table 34: ST-1218: Input and General Specifications

Items	Specification
Input Specification	
Inputs Per Module	8 Points, Positive Logic
Indicators	8 Green Input States, 1 Green/Red RSTi Bus State
ON-state Voltage	24Vdc nominal Minimum 10.2Vdc ~ Maximum 28.8Vdc
Minimum OFF-state Voltage	Maximum 5Vdc
ON-state Current	Maximum 6mA/Point @28.8Vdc
Input Signal Delay	OFF to ON: Maximum 3ms ON to OFF: Maximum 3ms
Nominal Input Impedance	Typical 5.1KΩ
Filtering Time	Typical 1.5ms
Common Type	External Common
General Specification	
Power Dissipation	Maximum 35mA @ 5.0Vdc
Isolation	I/O to Logic: Photo coupler isolation
Field Power	Supply Voltage: 24Vdc nominal Voltage Range: 11~28.8Vdc
Wiring	I/O Cable Maximum 2.0mm ² (AWG 14)
Weight	70g
Module Size	12mm x 99mm x 70mm
Environment Condition	See "Environmental Specifications" in Appendix A.

ST-121F

Interface and Data

The following illustration shows the interface design for ST-121F.

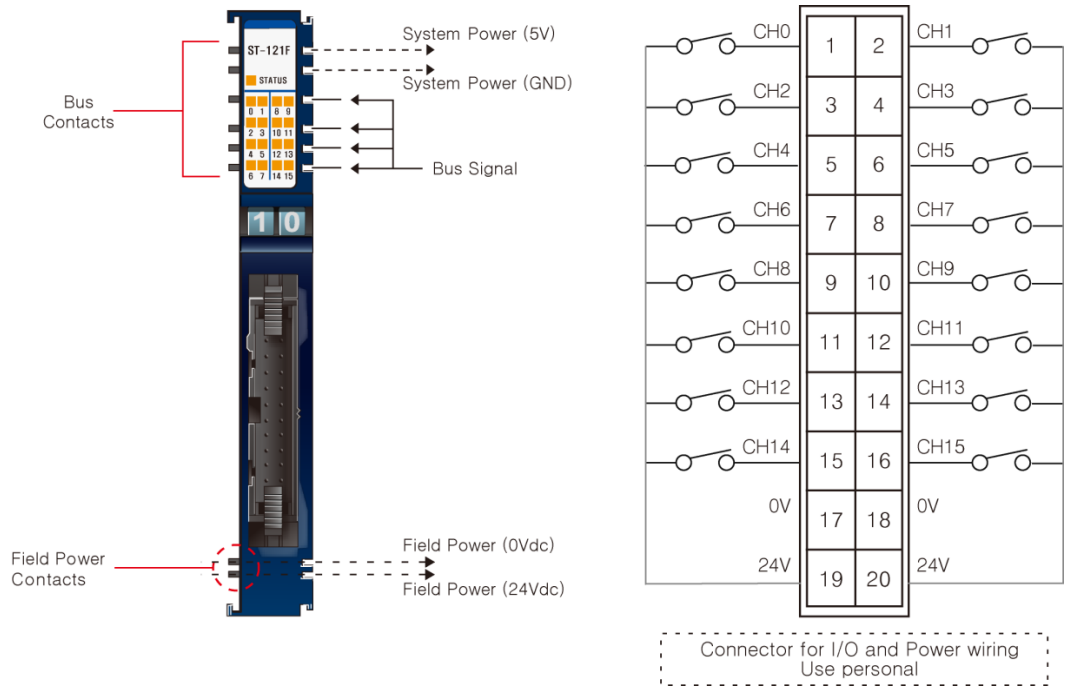

Figure 29: Discrete Input Module: ST-121F

The following table lists the pin numbers and description for ST-121F.

Table 35: ST-121F: Pin Description

Pin Number	Description	Pin Number	Description
1	Input Channel 0	2	Input Channel 1
3	Input Channel 2	4	Input Channel 3
5	Input Channel 4	6	Input Channel 5
7	Input Channel 6	8	Input Channel 7
9	Input Channel 8	10	Input Channel 9
11	Input Channel 10	12	Input Channel 11
13	Input Channel 12	14	Input Channel 13
15	Input Channel 14	16	Input Channel 15
17	Field Ground (0V)	18	Field Ground (0V)
19	Field Power (+24Vdc)	20	Field Power (+24Vdc)

Specification

The following table describes the Input Specifications and the General Specifications for ST-121F.

Table 36: ST-121F: Input and General Specifications

Items	Specification
Input Specification	
Inputs Per Module	16 Points, Positive Logic
Indicators	16 Green Input States, 1 Green/Red RSTi Bus State
ON-state Voltage	24Vdc nominal Minimum 10.2Vdc ~ Maximum 28.8Vdc
Minimum OFF-state Voltage	Maximum 5Vdc
ON-state Current	Maximum 6mA/Point @28.8Vdc
Input Signal Delay	OFF to ON: Maximum 3ms ON to OFF: Maximum 3ms
Nominal Input Impedance	Typical 5.1KΩ
Filtering Time	Typical 1.5ms
Common Type	16 Points/2COM
General Specification	
Power Dissipation	Maximum 45mA @ 5.0Vdc
Isolation	I/O to Logic: Photo coupler Isolation
Field Power	Supply Voltage: 24Vdc nominal Voltage Range: 11 ~28.8Vdc Power Dissipation: 5mA@28.8Vdc Per Point
Wiring	Module Connector: HIF3BA-20D-2.54C
Weight	70g
Module Size	12mm x 99mm x 70mm
Environment Condition	See "Environmental Specifications" in Appendix A.

ST-1224

Interface and Data

The following illustration shows the interface design for ST-1224.

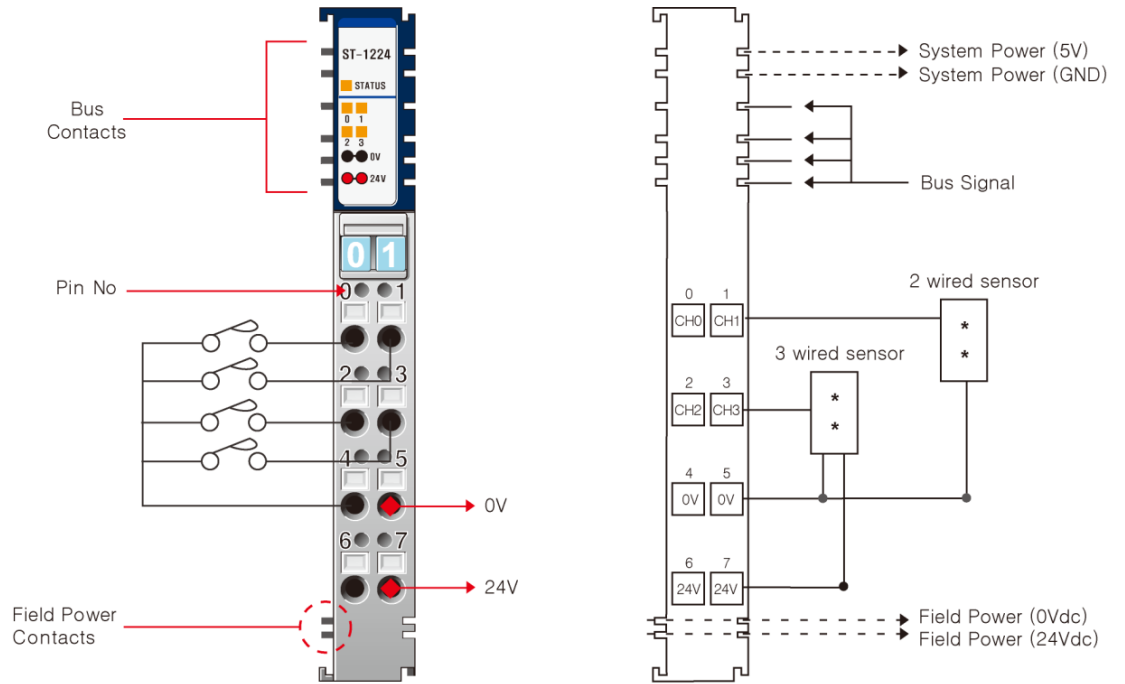

Figure 30: Discrete Input Module: ST-1224

The following table lists the pin numbers and description for ST-1224.

Table 37: ST-1224: Pin Description

<i>Pin Number</i>	<i>Description</i>	<i>Pin Number</i>	<i>Description</i>
0	Input Channel 0	1	Input Channel 1
2	Input Channel 2	3	Input Channel 3
4	Field Ground (0V)	5	Field Ground (0V)
6	Field Power (+24Vdc)	7	Field Power (+24Vdc)

Specification

The following table describes the Input Specifications and the General Specifications for ST-1224.

Table 38: ST-1224: Input and General Specifications

Items	Specification
Input Specification	
Inputs Per Module	4 Points, Negative Logic
Indicators	4 Green Input States, 1 Green/Red RSTi Bus State
ON-state Voltage	24Vdc nominal Minimum 10.2Vdc ~ Maximum 28.8Vdc
Minimum OFF-state Voltage	Maximum 5Vdc
ON-state Current	Maximum 6mA /Point @28.8Vdc
Input Signal Delay	OFF to ON: Maximum 3ms ON to OFF: Maximum 3ms
Nominal Input Impedance	Typical 5.1KΩ
Common Type	4 Points/2COM (Single Common)
General Specification	
Power Dissipation	Maximum 35mA @ 5.0Vdc
Isolation	I/O to Logic: Photo coupler isolation
Field Power	Supply Voltage: 24Vdc nominal Voltage Range:11~28.8Vdc
Wiring	I/O Cable Maximum 2.0mm ² (AWG 14)
Weight	70g
Module Size	12mm x 99mm x 70mm
Environment Condition	See "Environmental Specifications" in Appendix A.

ST-1228

Interface and Data

The following illustration shows the interface design for ST-1228.

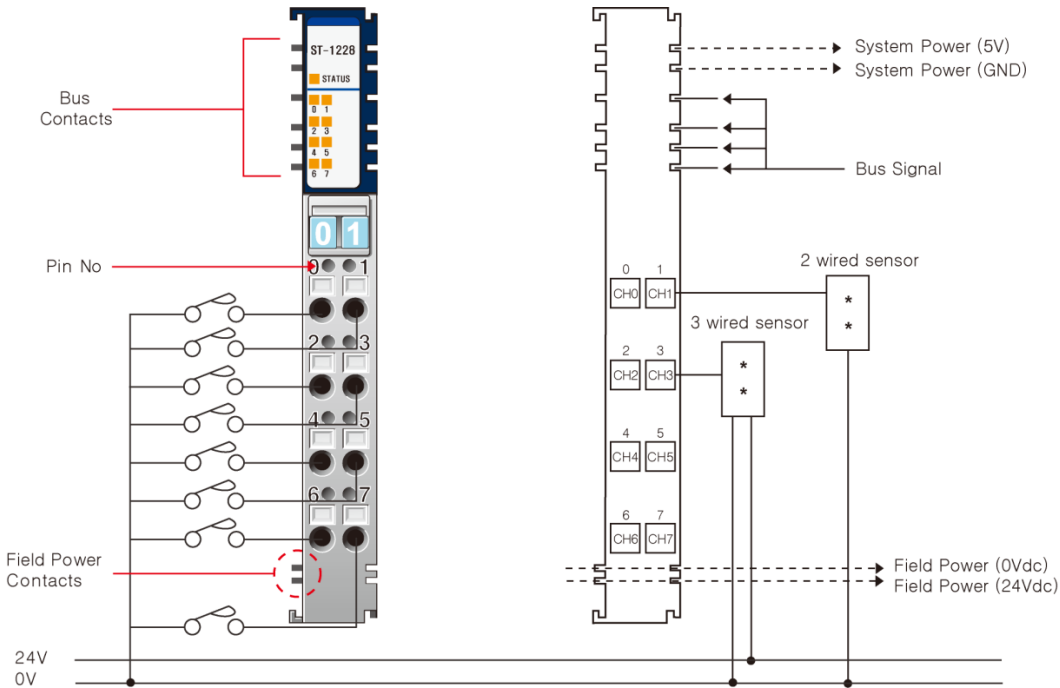

Figure 31: Discrete Input Module: ST-1228

The following table lists the pin numbers and description for ST-1228.

Table 39: ST-1228: Pin Description

<i>Pin Number</i>	<i>Description</i>	<i>Pin Number</i>	<i>Description</i>
0	Input Channel 0	1	Input Channel 1
2	Input Channel 2	3	Input Channel 3
4	Input Channel 4	5	Input Channel 5
6	Input Channel 6	7	Input Channel 7

Specification

The following table describes the Input Specifications and the General Specifications for ST-1228.

Table 40: ST-1228: Input and General Specifications

Items	Specification
Input Specification	
Inputs Per Module	8 Points, Negative Logic
Indicators	8 Green Input States, 1 Green/Red RSTi Bus State
ON-state Voltage	24Vdc nominal Minimum 10.2Vdc ~ Maximum 28.8Vdc
Minimum OFF-state Voltage	Maximum 5Vdc
ON-state Current	Maximum 6mA /Point @28.8Vdc
Input Signal Delay	OFF to ON: Maximum 3ms ON to OFF: Maximum 3ms
Nominal Input Impedance	Type. 5.1KΩ
Filtering Time	Typical 1.5ms
Common Type	External Common
General Specification	
Power Dissipation	Maximum 35mA @ 5.0Vdc
Isolation	I/O to Logic: Photo coupler isolation
Field Power	Supply Voltage: 24Vdc nominal Voltage Range: 11 ~ 28.8Vdc
Wiring	I/O Cable Maximum 2.0mm ² (AWG 14)
Weight	70g
Module Size	12mm x 99mm x 70mm
Environment Condition	See "Environmental Specifications" in Appendix A.

ST-122F

Interface and Data

The following illustration shows the interface design for ST-122F.

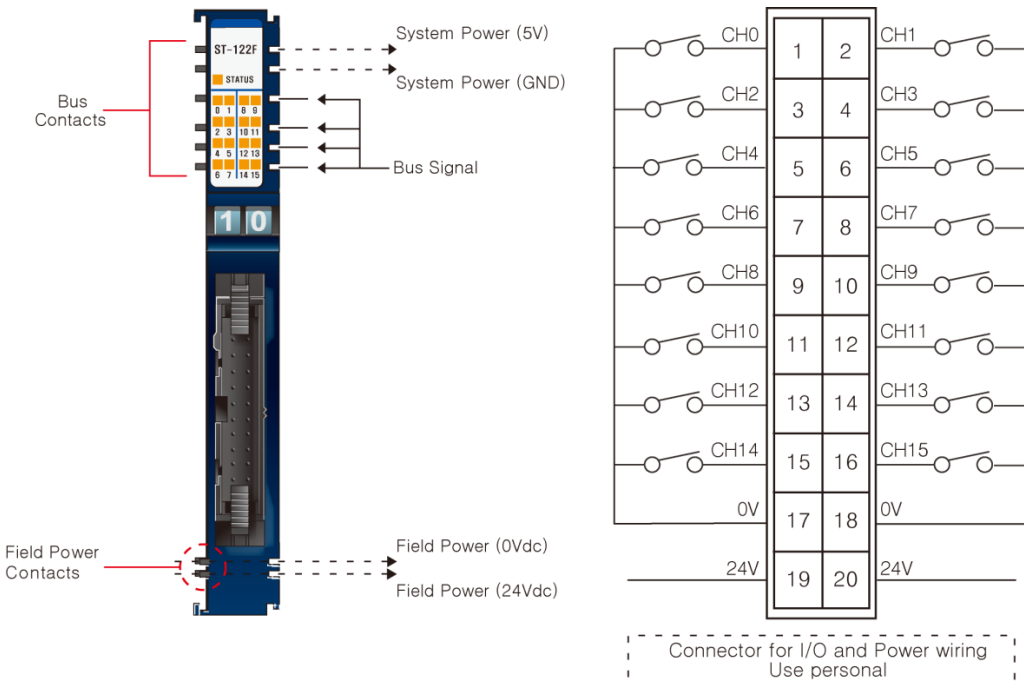

Figure 32: Discrete Input Module: ST-122F

The following table lists the pin numbers and description for ST-122F.

Table 41: ST-122F: Pin Description

Pin Number	Description	Pin Number	Description
1	Input Channel 0	2	Input Channel 1
3	Input Channel 2	4	Input Channel 3
5	Input Channel 4	6	Input Channel 5
7	Input Channel 6	8	Input Channel 7
9	Input Channel 8	10	Input Channel 9
11	Input Channel 10	12	Input Channel 11
13	Input Channel 12	14	Input Channel 13
15	Input Channel 14	16	Input Channel 15
17	Field Ground (0V)	18	Field Ground (0V)
19	Field Power (+24Vdc)	20	Field Power (+24Vdc)

Specification

The following table describes the Input Specifications and the General Specifications for ST-122F.

Table 42: ST-122F: Input and General Specifications

Items	Specification
Input Specification	
Inputs Per Module	16 Points, Negative Logic
Indicators	16 Green Input States, 1 Green/Red RSTi Bus State
ON-state Voltage	24Vdc nominal Minimum 10.2Vdc ~ Maximum 28.8Vdc
Minimum OFF-state Voltage	Maximum 5Vdc
ON-state Current	Maximum 6mA/Point @28.8Vdc
Input Signal Delay	OFF to ON: Maximum 3ms ON to OFF: Maximum 3ms
Filtering Time	Typical 1.5ms
Common Type	16 Points/2COM
General Specification	
Power Dissipation	Maximum 45mA @ 5.0Vdc
Isolation	I/O to Logic: Photo coupler Isolation
Field Power	Supply Voltage: 24Vdc nominal Voltage Range: Minimum 11 ~ Maximum 28.8Vdc Power Dissipation: 5mA@28.8Vdc Per Point
Wiring	Module Connector: HIF3BA-20D-2.54C
Weight	70g
Module Size	12mm x 99mm x 70mm
Environment Condition	See "Environmental Specifications" in Appendix A.

ST-1314

The following illustration shows the interface design for ST-1314.

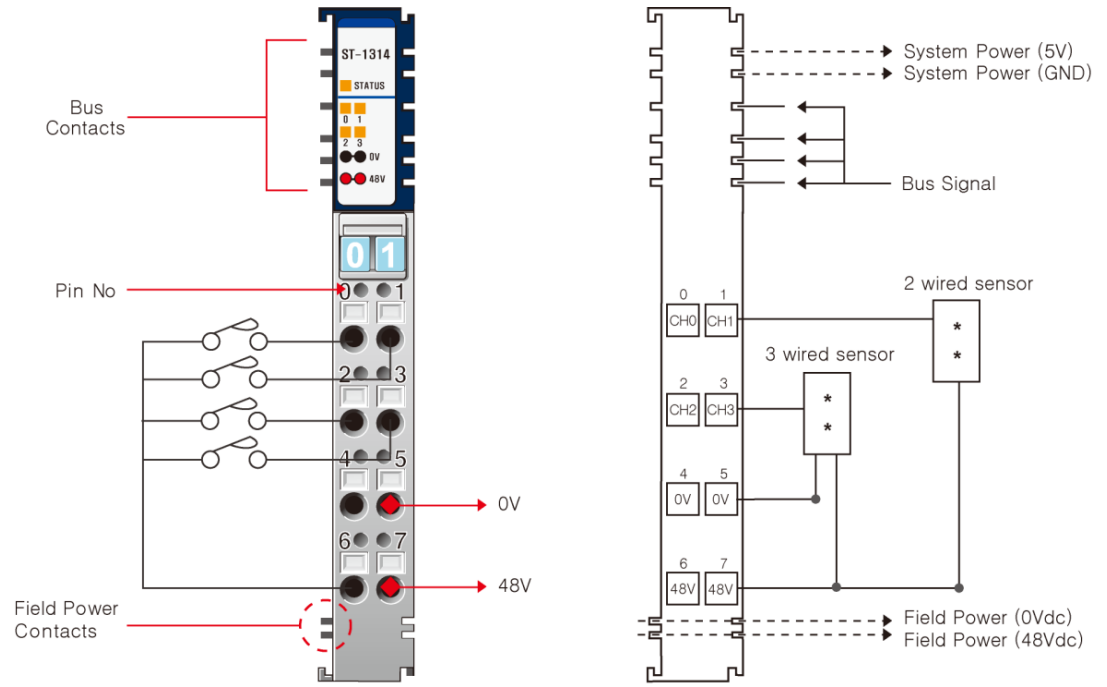

Figure 33: Discrete Input Module: ST-1314

The following table lists the pin numbers and description for ST-1314.

Table 43: ST-1314: Pin Description

<i>Pin Number</i>	<i>Description</i>	<i>Pin Number</i>	<i>Description</i>
0	Input Channel 0	1	Input Channel 1
2	Input Channel 2	3	Input Channel 3
4	Field Ground (0V)	5	Field Ground (0V)
6	Field Power (+48Vdc)	7	Field Power (+48Vdc)

Specification

The following table describes the Input Specifications and the General Specifications for ST-1314.

Table 44: ST-1314: Input and General Specifications

Items	Specification
Input Specification	
Inputs Per Module	4 Points, Positive Logic
Indicators	4 Green Input States, 1 Green/Red RSTi Bus State
ON-state Voltage	48Vdc nominal Minimum 34Vdc ~ Maximum 60Vdc
Minimum OFF-state Voltage	10Vdc Maximum
ON-state Current	Maximum 4mA/Point @ 48Vdc
Input Signal Delay	OFF to ON: Maximum 3ms ON to OFF: Maximum 3ms
Nominal Input Impedance	Typical 12K Ω
Common Type	4 Points/2COM (Single Common)
General Specification	
Power Dissipation	Maximum 35mA @ 5.0Vdc
Isolation	I/O to Logic: Photo coupler isolation
Field Power	Supply Voltage: 48Vdc nominal Voltage range: 34~60Vdc
Wiring	I/O Cable Maximum 2.0mm ² (AWG 14)
Weight	70g
Module Size	12mm x 99mm x 70mm
Environment Condition	See "Environmental Specifications" in Appendix A.

ST-131F

Interface and Data

The following illustration shows the interface design for ST-131F.

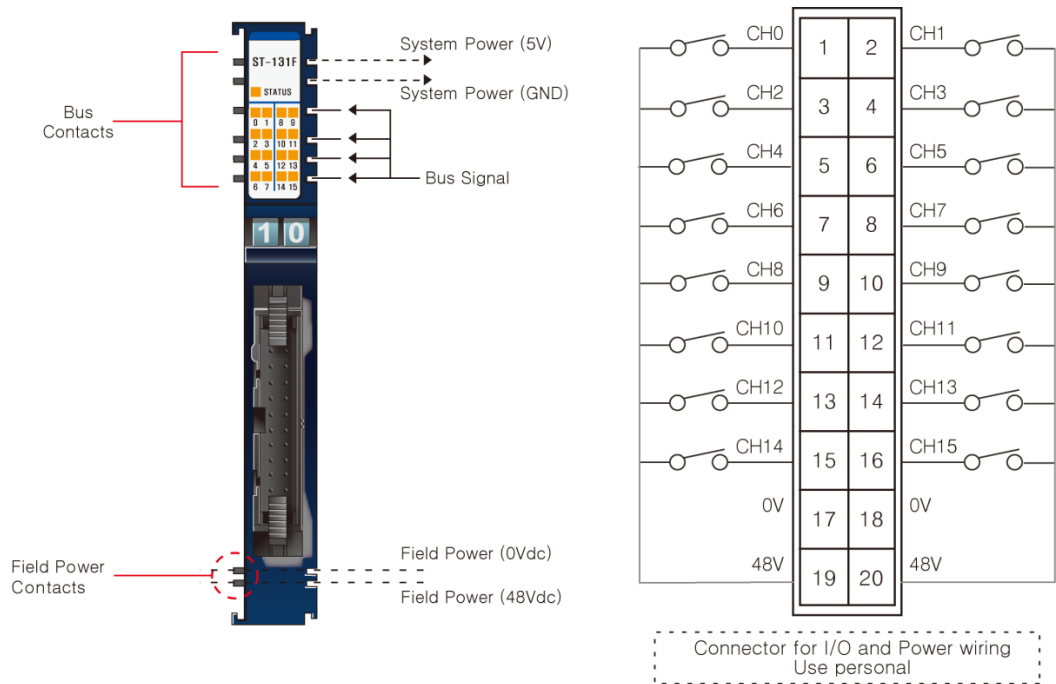

Figure 34: Discrete Input Module: ST-131F

The following table lists the pin numbers and description for ST-131F.

Table 45: ST-131F: Pin Description

Pin Number	Description	Pin Number	Description
1	Input Channel 0	2	Input Channel 1
3	Input Channel 2	4	Input Channel 3
5	Input Channel 4	6	Input Channel 5
7	Input Channel 6	8	Input Channel 7
9	Input Channel 8	10	Input Channel 9
11	Input Channel 10	12	Input Channel 11
13	Input Channel 12	14	Input Channel 13
15	Input Channel 14	16	Input Channel 15
17	Field Ground (0V)	18	Field Ground (0V)
19	Field Power (+48Vdc)	20	Field Power (+48Vdc)

Specification

The following table describes the Input Specifications and the General Specifications for ST-131F.

Table 46: ST-131F: Input and General Specifications

Items	Specification
Input Specification	
Inputs Per Module	16 Points, Positive Logic
Indicators	16 Green Input States, 1 Green/Red RSTi Bus State
ON-state Voltage	48Vdc nominal Minimum 34Vdc ~ Maximum 60Vdc
Minimum OFF-state Voltage	Maximum 20Vdc
ON-state Current	Maximum 2.5mA/Point @60Vdc
Input Signal Delay	OFF to ON: Maximum 3ms ON to OFF: Maximum 3ms
Nominal Input Impedance	Typical 27K Ω
Filtering Time	Typical 1.5ms (Software Filtering)
Common Type	16 Points/2COM
General Specification	
Power Dissipation	Maximum 45mA @ 5.0Vdc
Isolation	I/O to Logic: Photo coupler Isolation
Field Power	Supply Voltage: 48Vdc nominal Voltage Range: Minimum 34 ~ Maximum 60Vdc Power Dissipation: Max, 45mA@48Vdc
Wiring	Connector Type, up to AWG22 Module Connector: HIF3BA-20D-2.54C
Weight	70g
Module Size	12mm x 99mm x 70mm
Environment Condition	See "Environmental Specifications" in Appendix A.

ST-1324

Interface and Data

The following illustration shows the interface design for ST-1324.

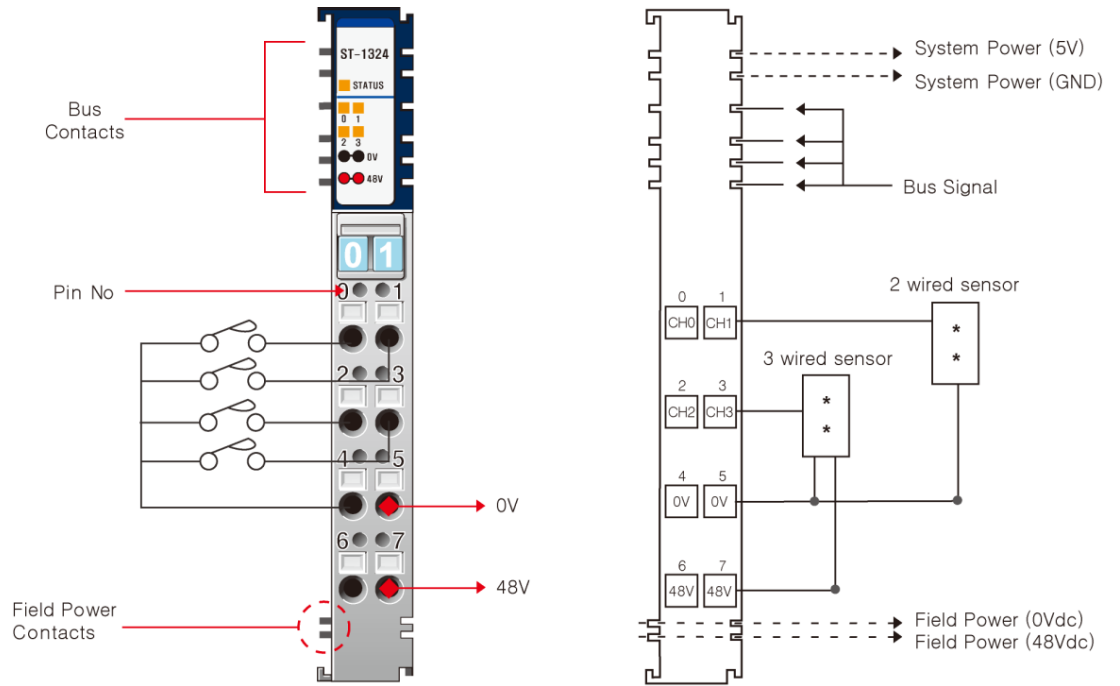

Figure 35: Discrete Input Module: ST-1324

The following table lists the pin numbers and description for ST-1324.

Table 47: ST-1324: Pin Description

<i>Pin Number</i>	<i>Description</i>	<i>Pin Number</i>	<i>Description</i>
0	Input Channel 0	1	Input Channel 1
2	Input Channel 2	3	Input Channel 3
4	Field Ground (0V)	5	Field Ground (0V)
6	Field Power (+48Vdc)	7	Field Power (+48Vdc)

Specification

The following table describes the Input Specifications and the General Specifications for ST-1324.

Table 48: ST-1324: Input and General Specifications

Items	Specification
Input Specification	
Inputs Per Module	4 Points, Negative Logic
Indicators	4 Green Input States, 1 Green/Red RSTi Bus State
ON-state Voltage	48Vdc nominal Minimum 34Vdc ~ Maximum 60Vdc
Minimum OFF-state Voltage	Maximum 10Vdc
ON-state Current	Maximum 4mA / Point @ 48Vdc
Input Signal Delay	OFF to ON: Maximum 3ms ON to OFF: Maximum 3ms
Nominal Input Impedance	Typical 12K Ω
Common Type	4 Points/2 COM (Single Common)
General Specification	
Power Dissipation	Maximum 35mA @ 5.0Vdc
Isolation	I/O to Logic: Photo coupler isolation
Field Power	Supply Voltage: 48Vdc nominal Voltage range: 34~60Vdc
Wiring	I/O Cable Maximum 2.0mm ² (AWG 14)
Weight	70g
Module Size	12mm x 99mm x 70mm
Environment Condition	See "Environmental Specifications" in Appendix A.

ST-1804

Interface and Data

The following illustration shows the interface design for ST-1804.

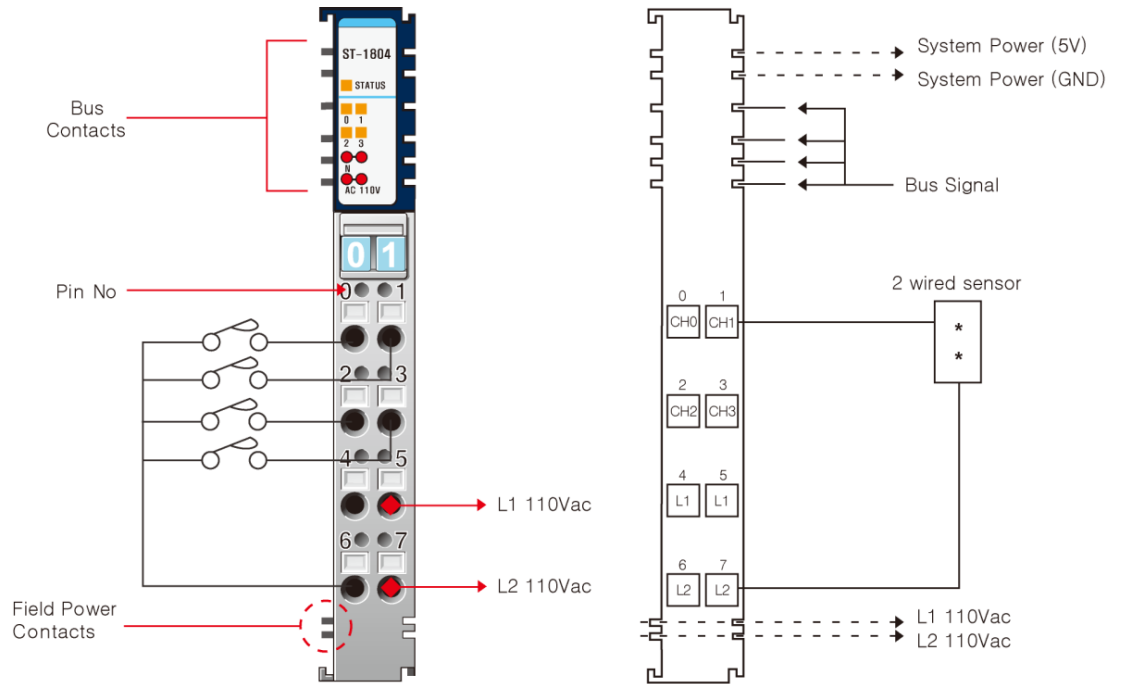

Figure 36: Discrete Input Module: ST-1804

The following table lists the pin numbers and description for ST-1804.

Table 49: ST-1804: Pin Description

Pin Number	Description	Pin Number	Description
0	Input Channel 0	1	Input Channel 1
2	Input Channel 2	3	Input Channel 3
4	L1	5	L1
6	L2	7	L2

Specification

The following table describes the Input Specifications and the General Specifications for ST-1804.

Table 50: ST-1804: Input and General Specifications

Items	Specification
Input Specification	
Inputs Per Module	4 Points
Indicators	4 Green Input States, 1 Green/Red RSTi Bus State
ON-state Voltage	110Vac nominal Minimum 85Vac ~ Maximum 132Vac
Minimum OFF-state Voltage	Maximum 45Vac
ON-state Current	Maximum 8mA/Point @ 132Vac
Input Signal Delay	OFF to ON: Maximum 10ms ON to OFF: Maximum 10ms
Nominal Input Impedance	Typical 11K Ω
Frequency Range	47-63Hz
Common Type	4 Points/2COM (Single Common)
General Specification	
Power Dissipation	Maximum 35mA @ 5.0Vdc
Isolation	I/O to Logic: Photo coupler isolation
Field Power	Supply Voltage: 120Vac nominal Voltage Range: Minimum 85Vac ~ Maximum 132Vac
Wiring	I/O Cable Maximum 2.0mm ² (AWG 14)
Weight	70g
Module Size	12mm x 99mm x 70mm
Environment Condition	See "Environmental Specifications" in Appendix A.

ST-1904

Interface and Data

The following illustration shows the interface design for ST-1904.

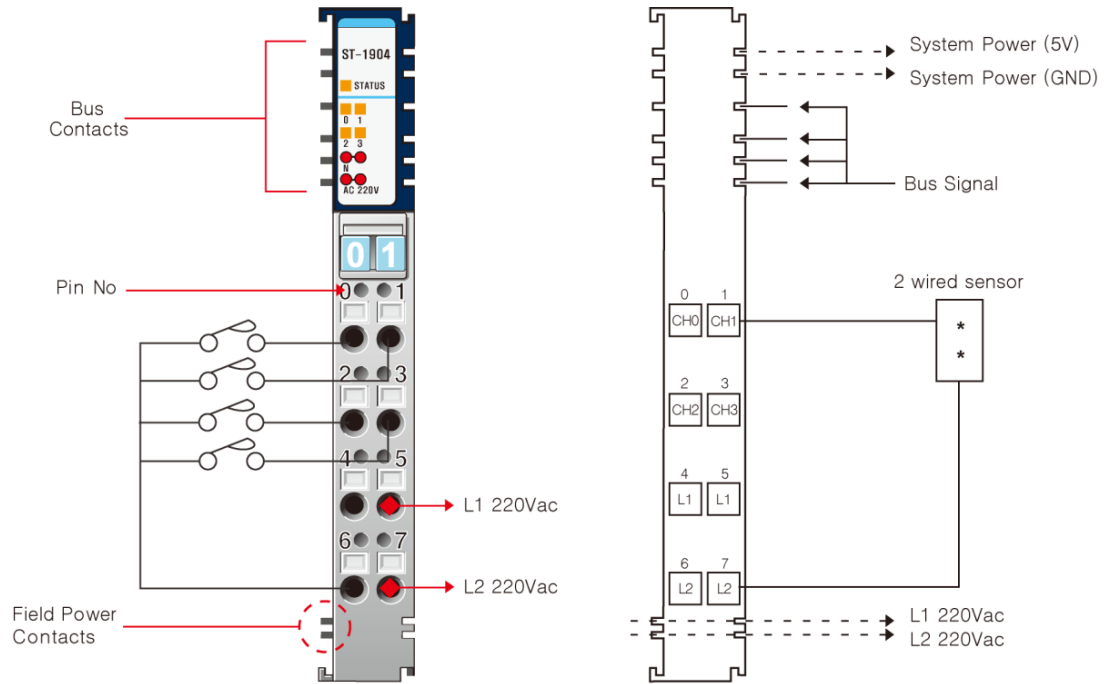

Figure 37: Analog Output Module: ST-1904

The following table lists the pin numbers and description for ST-1904.

Table 51: ST-1904: Pin Description

<i>Pin Number</i>	<i>Description</i>	<i>Pin Number</i>	<i>Description</i>
0	Input Channel 0	1	Input Channel 1
2	Input Channel 2	3	Input Channel 3
4	L1	5	L1
6	L2	7	L2

Specification

The following table describes the Input Specifications and the General Specifications for ST-1904.

Table 52: ST-1904: Input and General Specifications

Items	Specification
Input Specification	
Inputs Per Module	4 Points
Indicators	4 Green Input States, 1 Green/Red RSTi Bus State
ON-state Voltage	240Vac nominal Minimum 170Vac to Maximum 264Vac
Minimum OFF-state Voltage	Maximum 45Vac
ON-state Current	Maximum 12mA/Point @ 264Vac
Input Signal Delay	OFF to ON: Maximum 10ms ON to OFF: Maximum 10ms
Nominal Input Impedance	Typical 22KΩ
Frequency Range	47-63Hz
Common Type	4 Points/2COM (Single Common)
General Specification	
Power Dissipation	Maximum 35mA @ 5.0Vdc
Isolation	I/O to Logic: Photo coupler isolation
Field Power	Supply Voltage: 240Vac nominal Voltage Range: Minimum 170 to Maximum 264Vac
Wiring	I/O Cable Maximum 2.0mm ² (AWG 14)
Weight	70g
Module Size	12mm x 99mm x 70mm
Environment Condition	See "Environmental Specifications" in Appendix A.

Dimension

ST-1xx4 and ST-1xx8

The following illustration shows the dimensions for ST-1xx4 and ST-1xx8 series.

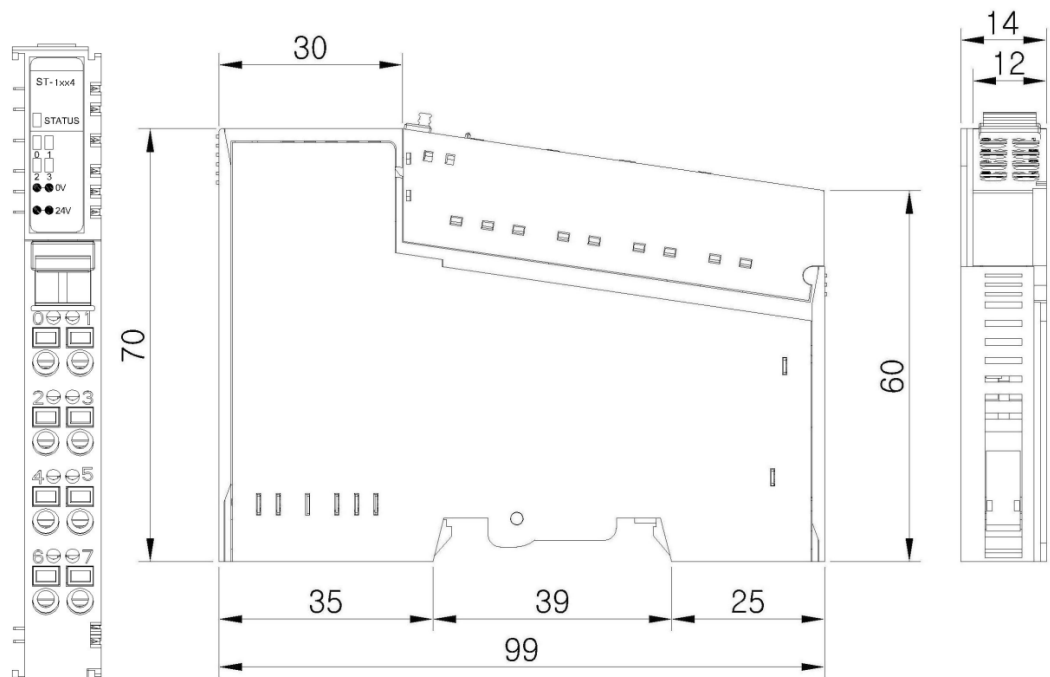

Figure 38: ST-1xxs and ST-1xx8 Dimensions

ST-1xxF

The following illustration shows the dimension for ST-1xxF.

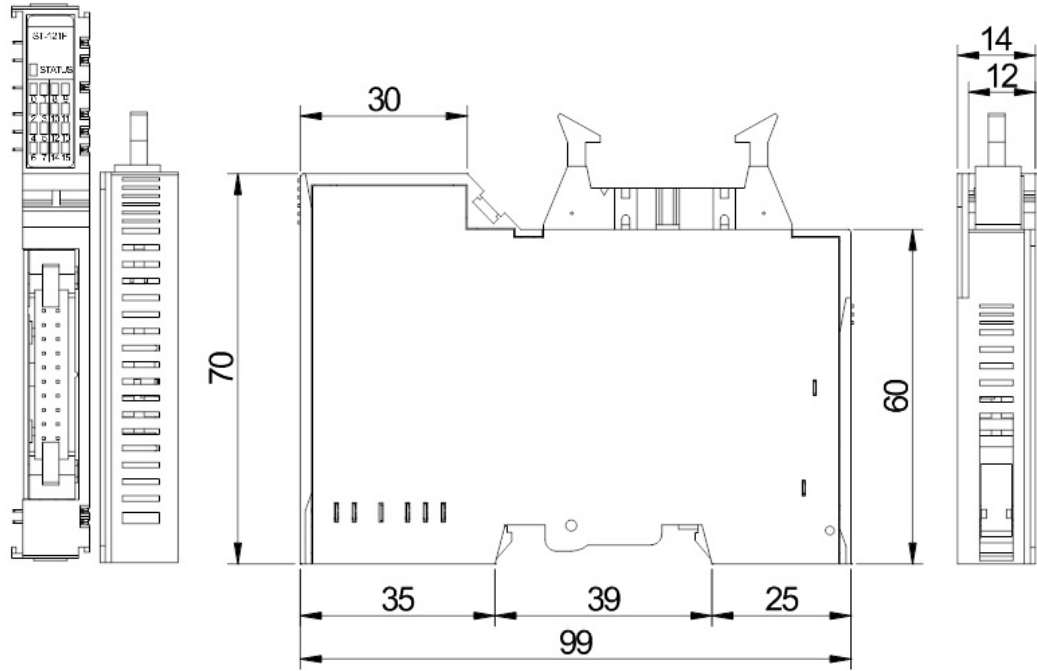

Figure 39: ST-1xxF Dimension

Mapping Data into the Image Table

ST-1xx4

Input Module Data

D3	D2	D1	D0
----	----	----	----



Input Image Value

Bit No	Bit 7	Bit 6	Bit 5	Bit 4	Bit 3	Bit 2	Bit 1	Bit 0
Byte 0	Reserved				D3	D2	D1	D0

ST-1xx8

Input Module Data

D7	D6	D5	D4	D3	D2	D1	D0
----	----	----	----	----	----	----	----



Input Image Value

Bit No	Bit 7	Bit 6	Bit 5	Bit 4	Bit 3	Bit 2	Bit 1	Bit 0
Byte 0	D7	D6	D5	D4	D3	D2	D1	D0

ST-1xxF

Input Module Data

D7	D6	D5	D4	D3	D2	D1	D0
D15	D14	D13	D12	D11	D10	D9	D8



Input Image Value

Bit No	Bit 7	Bit 6	Bit 5	Bit 4	Bit 3	Bit 2	Bit 1	Bit 0
Byte 0	D7	D6	D5	D4	D3	D2	D1	D0
Byte 1	D15	D14	D13	D12	D11	D10	D9	D8

Diagnostics

Normal Module

The LEDs indicate the status of the module. The table below shows the corresponding functions of LEDs during normal operation. You can use this table as a reference for troubleshooting errors.

Table 53: Normal Module

<i>Color</i>	<i>Status</i>	<i>Function</i>
<i>IO Modules Status LED</i>		
Off	Not Power No Initialized	Device has no expansion Module or may not be powered The Parameter is not initialized yet.
Solid Green	RSTi Bus Connection	RSTi Bus Normal Operation
Flashing Green	RSTi Bus Ready	RSTi Bus Ready
Flashing Red	RSTi Bus Fault	RSTi Bus Time Out, RSTi Bus Failed Communication
Solid Red	Device Fault	Device fault
<i>Channel Status LED</i>		
Off	No Signal	Normal Operation
Solid Green	On Signal	Normal Operation

Note: For more help on troubleshooting errors related to Network Adaptor and its protocols, please refer to Network Adaptor User Manual.

Discrete Output Modules consists of Negative Logic Type, Positive Logic Type, Relay, and Triac modules ranging from 2 points to 16 points.

DC 24V/0.5 type is available with 4 points and 8 points and DC 24V/0.3A type is available with 16 points. The DC 24V/2A for output modules can be used without any relay for any large output required.

The Diagnostic Module is used for detection of output errors.

ST-2114

Interface and Data

The following illustration shows the interface design for ST-2114.

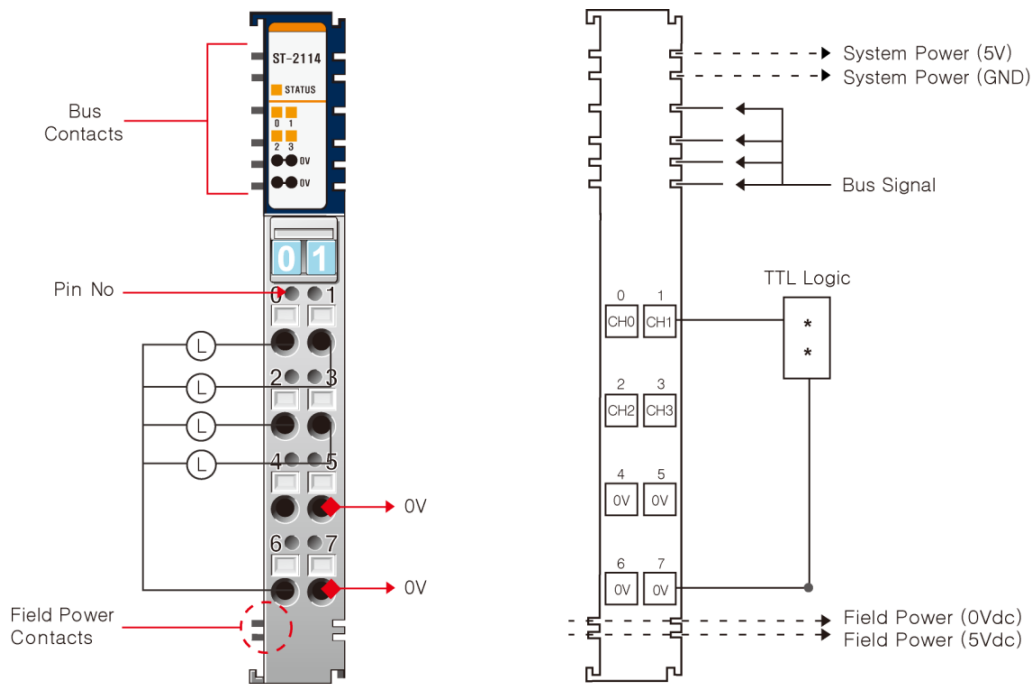

Figure 40: Discrete Output Module: ST-2114

The following table lists the pin numbers and description for ST-2114.

Table 54: ST-2114: Pin Description

Pin Number	Description	Pin Number	Description
0	Output Channel 0	1	Output Channel 1
2	Output Channel 2	3	Output Channel 3
4	Field Ground (0V)	5	Field Ground (0V)
6	Field Ground (0V)	7	Field Ground (0V)

Specification

The following table describes the Output Specifications and the General Specifications for ST-2114.

Table 55: ST-2114: Output and General Specifications

Items	Specification
Output Specification	
Outputs Per Module	4 Points, TTL Inverting (Positive Logic) Output (Default:5V)
Indicators	4 Green Output States, 1 Green/Red RSTi Bus State
Output Voltage Range	5Vdc nominal, Minimum 4.5Vdc to Maximum 5.5Vdc
Operating Frequency	DC to 50Khz
High-Level Output Voltage	Minimum 4.8Vdc@5Vdc, 5mA
Low-Level Output Voltage	Maximum 0.3Vdc@0Vdc, 5mA
Output Signal Delay	OFF to ON: Maximum 0.3ms ON to OFF: Maximum 0.3ms
Output Current Rating	Maximum 20mA Per Channel Maximum 80mA All Common
Protection	Output Short-Circuit protection Field Power Over Voltage Protection (about 6.7Vdc) Field Power Reverse Voltage Protection
Surge Current	40mA For 10ms, Repeatable Every 1 Sec.
Common Type	4 Points/4COM (Single Common)
General Specification	
Power Dissipation	Maximum 50mA @ 5.0Vdc
Isolation	I/O to Logic: Photo coupler isolation
Field Power	Voltage Range: 4.5~5.5Vdc Supply Voltage: 5Vdc nominal
Wiring	I/O Cable Maximum 2.0mm ² (AWG 14)
Weight	70g
Module Size	12mm x 99mm x 70mm
Environment Condition	See "Environmental Specifications" in Appendix A.

ST-2124

Interface and Data

The following illustration shows the interface design for ST-2124.

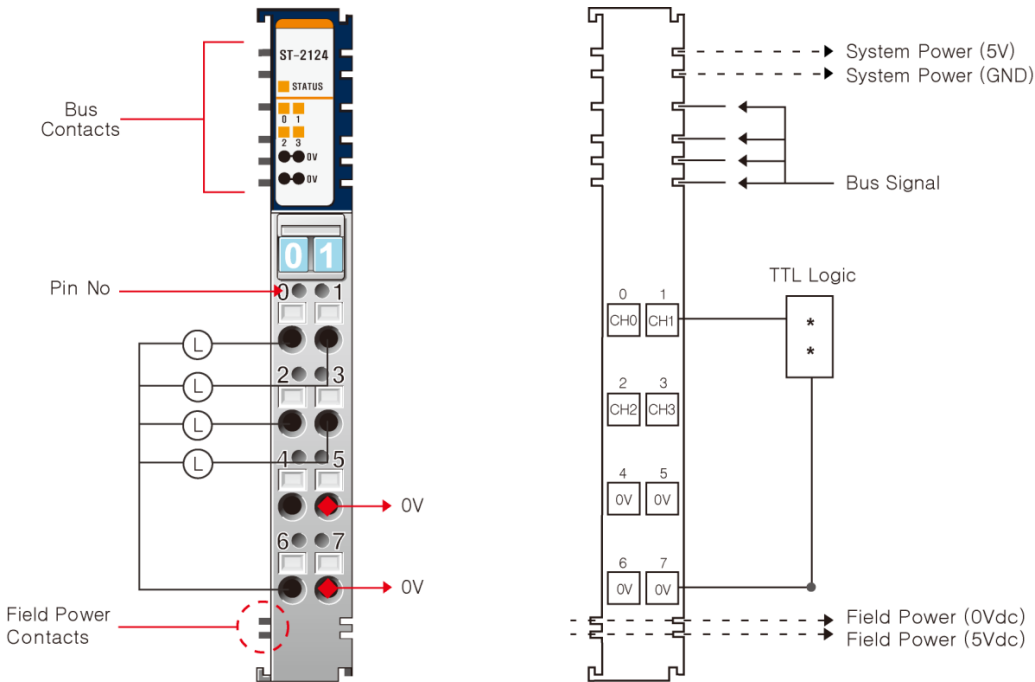

Figure 41: Discrete Output Module: ST-2124

The following table lists the pin numbers and description for ST-2124.

Table 56: ST-2124: Pin Description

<i>Pin Number</i>	<i>Description</i>	<i>Pin Number</i>	<i>Description</i>
0	Output Channel 0	1	Output Channel 1
2	Output Channel 2	3	Output Channel 3
4	Field Ground (0V)	5	Field Ground (0V)
6	Field Ground (0V)	7	Field Ground (0V)

Specification

The following table describes the Output Specifications and the General Specifications for ST-2124.

Table 57: ST-2124: Output and General Specifications

Items	Specification
Output Specification	
Outputs Per Module	4 Points, TTL Non-Inverting (Positive Logic) Output (Default: 0V)
Indicators	4 Green Output States, 1 Green/Red RSTi Bus State
Output Voltage Range	5Vdc nominal, Minimum 4.5Vdc to Maximum 5.5Vdc
Operating Frequency	DC to 50Khz
High-Level Output Voltage	Minimum 4.8Vdc@5Vdc, 5mA
Low-Level Output Voltage	Maximum 0.3Vdc@0Vdc, 5mA
Output Signal Delay	OFF to ON: Maximum 0.3ms ON to OFF: Maximum 0.3ms
Output Current Rating	Maximum 20mA Per Channel Maximum 80mA All Common
Protection	Output Short-Circuit protection Field Power Over Voltage Protection (about 6Vdc) Field Power Reverse Voltage Protection
Surge Current	40mA For 10ms, Repeatable Every 1 Sec.
Common Type	4 Points/4COM (Single Common)
General Specification	
Power Dissipation	Maximum 50mA @ 5.0Vdc
Isolation	I/O to Logic: Photo coupler isolation
Field Power	Supply Voltage: 5Vdc nominal Voltage Range: 4.5~5.5Vdc
Wiring	I/O Cable Maximum 2.0mm ² (AWG 14)
Weight	70g
Module Size	12mm x 99mm x 70mm
Environment Condition	See "Environmental Specifications" in Appendix A.

ST-2314

Interface and Data

The following illustration shows the interface design for ST-2314.

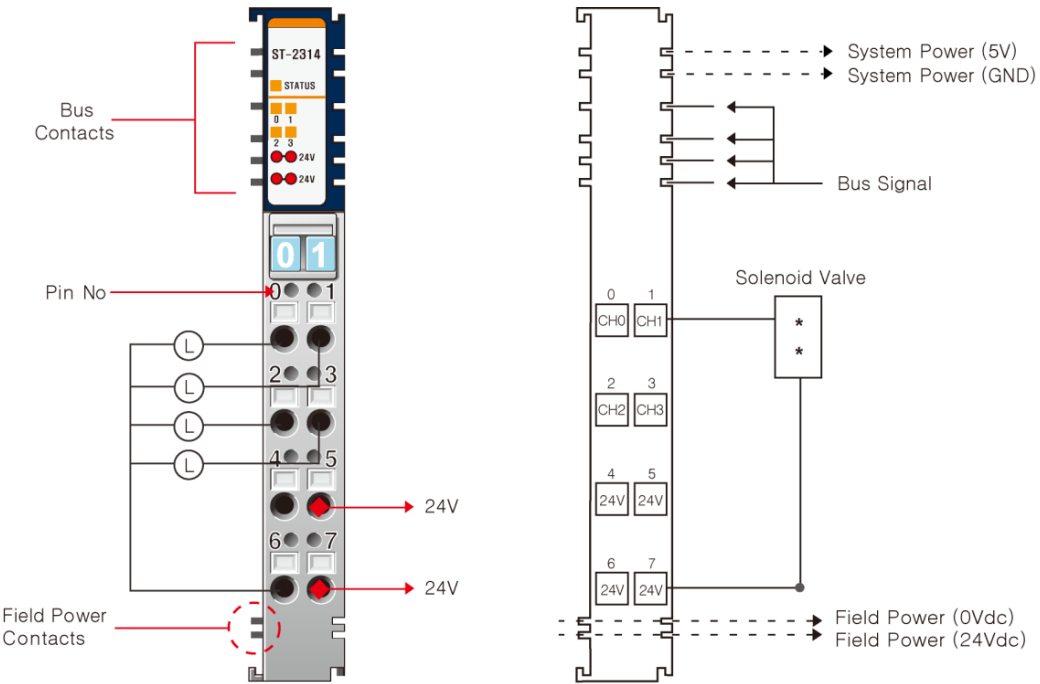

Figure 42: Discrete Output Module: ST-2314

The following table lists the pin numbers and description for ST-2314.

Table 58: ST-2314: Pin Description

Pin Number	Description	Pin Number	Description
0	Output Channel 0	1	Output Channel 1
2	Output Channel 2	3	Output Channel 3
4	Field Ground (+24Vdc)	5	Field Ground (+24Vdc)
6	Field Ground (+24Vdc)	7	Field Ground (+24Vdc)

Specification

The following table describes the Output Specifications and the General Specifications for ST-2314.

Table 59: ST-2314: Output and General Specifications

Items	Specification
Output Specification	
Outputs Per Module	4 Points, Negative Logic
Indicators	4 Green Output States, 1 Green/Red RSTi Bus State
Output Voltage Range	24Vdc nominal, Minimum 11Vdc to Maximum 28.8Vdc
ON-state Voltage Drop	Maximum 0.3Vdc@25°C
ON-state Minimum Current	1mA Per Channel
OFF-State Leakage Current	Maximum 50uA
Output Signal Delay	OFF to ON: Maximum 0.3ms ON to OFF: Maximum 0.3ms
Output Current Rating	Maximum 0.5A Per Channel Maximum 2.0A All Common
Output Protection	Over Temperature Shutdown: Minimum 150°C Over Current Limit: Minimum 3.5A/Maximum 7A Per Channel Short Circuit Protection ESD Protection: 16.5Kv
Common Type	4 Points/4COM (Single Common)
General Specification	
Power Dissipation	Maximum 45mA @ 5.0Vdc
Isolation	I/O to Logic: Photo coupler isolation
Field Power	Field Power: Non-isolation Supply Voltage: 24Vdc nominal Voltage Range: 11~28.8Vdc Power Dissipation: 5mA@28.8Vdc per Channel
Wiring	I/O Cable Maximum 2.0mm Cable Max
Weight	70g
Module Size	12mm x 99mm x 70mm
Environment Condition	See "Environmental Specifications" in Appendix A.

ST-2324

Interface and Data

The following illustration shows the interface design for ST-2324.

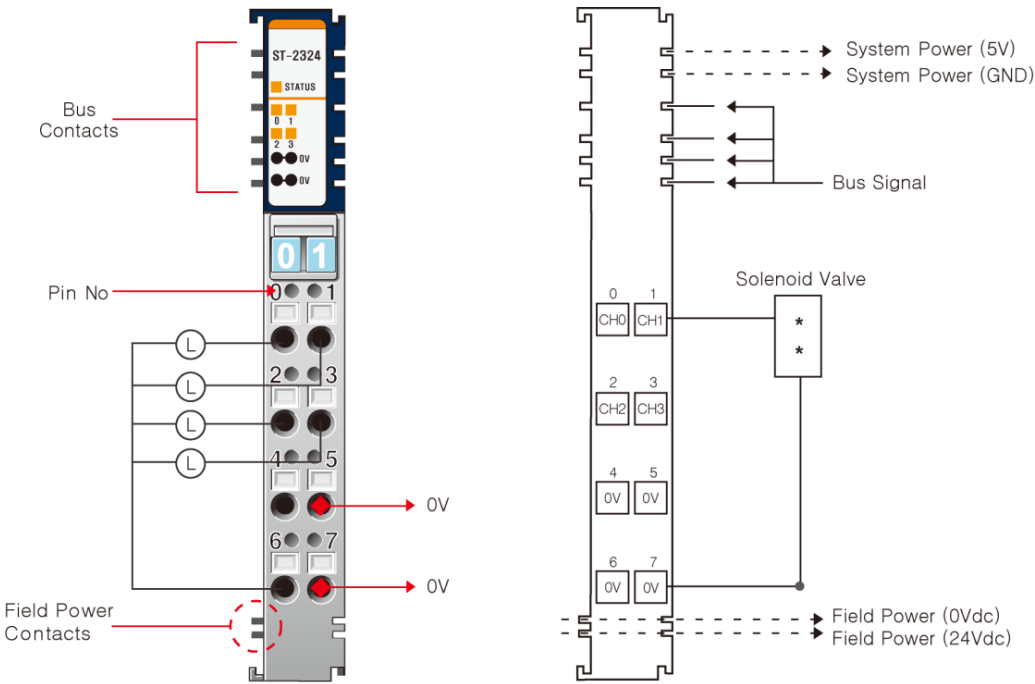

Figure 43: Discrete Output Module: ST-2324

The following table lists the pin numbers and description for ST-2324.

Table 60: ST-2324: Pin Description

Pin Number	Description	Pin Number	Description
0	Output Channel 0	1	Output Channel 1
2	Output Channel 2	3	Output Channel 3
4	Field Ground (0V)	5	Field Ground (0V)
6	Field Ground (0V)	7	Field Ground (0V)

Specification

The following table describes the Output Specifications and the General Specifications for ST-2324.

Table 61: ST-2324: Output and General Specifications

Items	Specification
Output Specification	
Outputs Per Module	4 Points, Positive Logic
Indicators	4 Green Output States
Output Voltage Range	24Vdc nominal
ON-state Voltage Drop	Maximum 0.3Vdc@25°C
ON-state Minimum Current	1mA Per Channel
OFF-State Leakage Current	Maximum 50uA
Output Signal Delay	OFF to ON: Maximum 0.3ms ON to OFF: Maximum 0.3ms
Output Current Rating	Maximum 0.5A Per Channel Maximum 2.0A All Common
Output Protection	Over Temperature Shutdown: Minimum 150°C Over Current Limit: Minimum 3.5A/Maximum 7A Per Channel Short Circuit Protection ESD Protection: 5.0Kv
Common Type	4 Points/4COM (Single Common)
General Specification	
Power Dissipation	Maximum 45mA @ 5.0Vdc
Isolation	I/O to Logic: Photo coupler isolation Field Power: Non-isolation
Field Power	Supply Voltage: 24Vdc nominal Voltage Range: 11~28.8Vdc Power Dissipation: 5mA@28.8Vdc per Channel
Wiring	I/O Cable Maximum 2.0mm ² (AWG 14)
Weight	70g
Module Size	12mm x 99mm x 70mm
Environment Condition	See "Environmental Specifications" in Appendix A.

ST-2414

Interface and Data

The following illustration shows the interface design for ST-2414.

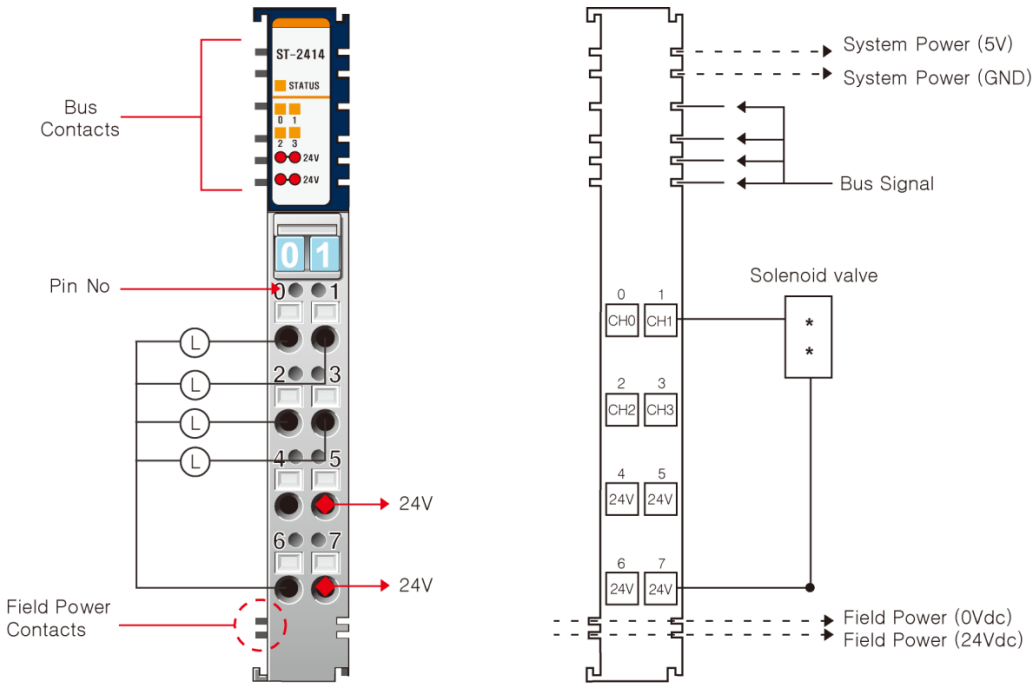

Figure 44: Discrete Output Module: ST-2324

The following table lists the pin numbers and description for ST-2414.

Table 62: ST-2414: Pin Description

Pin Number	Description	Pin Number	Description
0	Output Channel 0	1	Output Channel 1
2	Output Channel 2	3	Output Channel 3
4	Field Power (+24Vdc)	5	Field Power (+24Vdc)
6	Field Power (+24Vdc)	7	Field Power (+24Vdc)

Specification

The following table describes the Output Specifications and the General Specifications for ST-2414.

Table 63: ST-2414: Output and General Specifications

Items	Specification
Output Specification	
Outputs Per Module	4 Points, Negative Logic
Indicators	4 Green/Red Output States, 1 Green/Red RSTi Bus State
Output Voltage Range	24Vdc nominal, Minimum 11Vdc to Maximum 28.8Vdc
ON-state Voltage Drop	Maximum 0.3Vdc@25°C
ON-state Minimum Current	1mA Per Channel
OFF-State Leakage Current	Maximum 50uA
Output Signal Delay	OFF to ON: Maximum 0.3ms ON to OFF: Maximum 0.3ms
Output Current Rating	Maximum 0.5A Per Channel Maximum 2.0A All Common
Output Protection	Over Temperature Shutdown: Minimum 150°C Over Current Limit: Minimum 3.5A/Maximum 7.5A Per Channel Short Circuit Protection ESD Protection: 16.5.0Kv
Common Type	4 Points/4COM (Single Common)
General Specification	
Power Dissipation	Maximum 45mA @ 5.0Vdc
Isolation	I/O to Logic: Photo coupler isolation Field Power: Non-isolation
Field Power	Supply Voltage: 24Vdc nominal Voltage Range: 11~28.8Vdc Power Dissipation: 5mA@28.8Vdc per Channel
Wiring	I/O Cable Maximum 2.0mm ² (AWG 14)
Weight	70g
Module Size	12mm x 99mm x 70mm
Environment Condition	See "Environmental Specifications" in Appendix A.

ST-2424

Interface and Data

The following illustration shows the interface design for ST-2424.

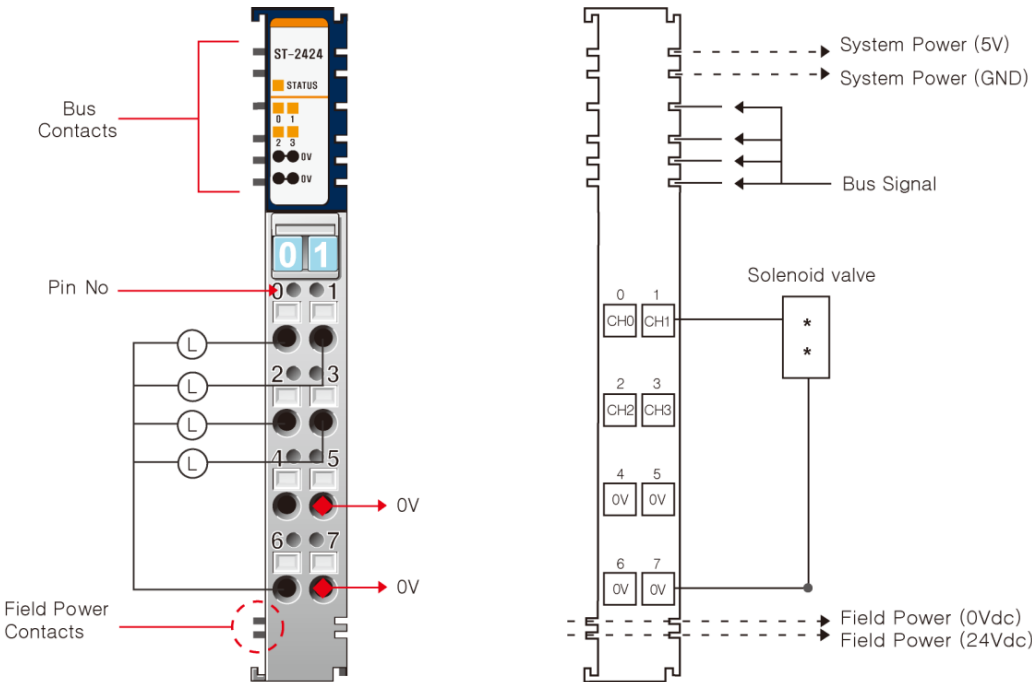

Figure 45: Discrete Output Module: ST-2424

The following table lists the pin numbers and description for ST-2424.

Table 64: ST-2424: Pin Description

<i>Pin Number</i>	<i>Description</i>	<i>Pin Number</i>	<i>Description</i>
0	Output Channel 0	1	Output Channel 1
2	Output Channel 2	3	Output Channel 3
4	Field Ground (0V)	5	Field Ground (0V)
6	Field Ground (0V)	7	Field Ground (0V)

Specification

The following table describes the Output Specifications and the General Specifications for ST-2424.

Table 65: ST-2424: Output and General Specifications

Items	Specification
Output Specification	
Outputs Per Module	4 Points, Positive Logic
Indicators	4 Green/Red Output States, 1 Green/Red RSTi Bus State
Output Voltage Range	24Vdc nominal, Minimum 11Vdc to Maximum 28.8Vdc
ON-state Voltage Drop	Maximum 0.3Vdc@25°C
ON-state Minimum Current	1mA Per Channel
OFF-State Leakage Current	Maximum 50uA
Output Signal Delay	OFF to ON: Maximum 0.3ms ON to OFF: Maximum 0.3ms
Output Current Rating	Maximum 0.5A Per Channel Maximum 2.0A All Common
Output Protection	Over Temperature Shutdown: Minimum 150°C Over Current Limit: Minimum 3.5A/Maximum 7.5A Per Channel Short Circuit Protection ESD Protection: 5.0Kv
Common Type	4 Points/4COM (Single Common)
General Specification	
Power Dissipation	Maximum 45mA @ 5.0Vdc
Isolation	I/O to Logic: Photo coupler isolation Field Power: Non-isolation
Field Power	Supply Voltage: 24Vdc nominal Voltage Range: 11~28.8Vdc Power Dissipation: 5mA@28.8Vdc per Channel
Wiring	I/O Cable Maximum 2.0mm ² (AWG 14)
Weight	70g
Module Size	12mm x 99mm x 70mm
Environment Condition	See "Environmental Specifications" in Appendix A.

ST-2514

Interface and Data

The following illustration shows the interface design for ST-2514.

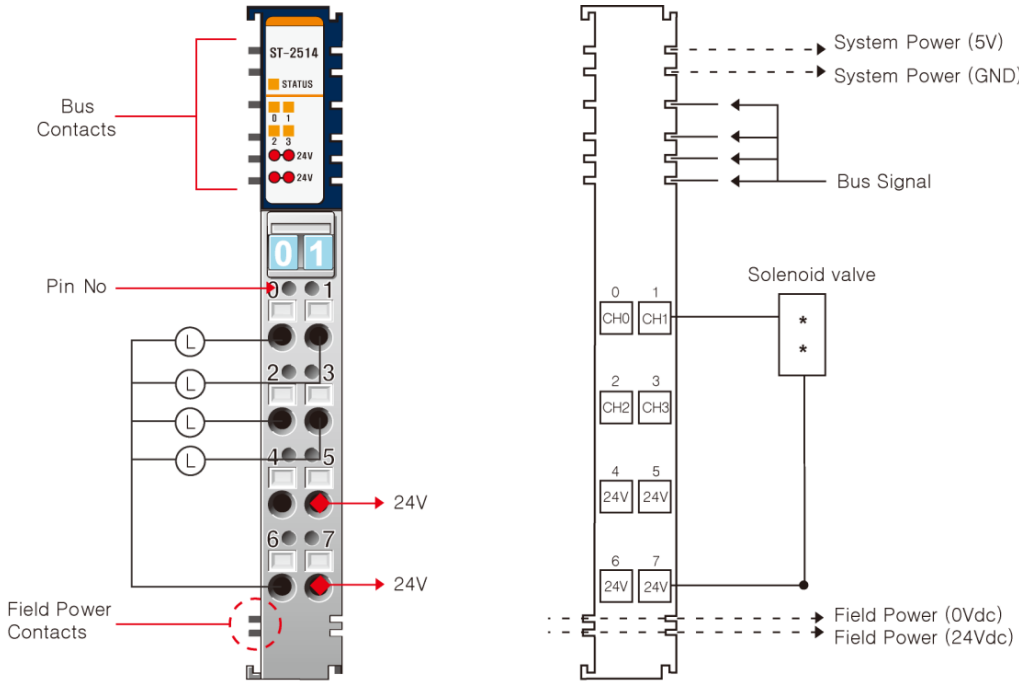

Figure 46: Discrete Output Module: ST-2514

The following table lists the pin numbers and description for ST-2514.

Table 66: ST-2514: Pin Description

<i>Pin Number</i>	<i>Description</i>	<i>Pin Number</i>	<i>Description</i>
0	Output Channel 0	1	Output Channel 1
2	Output Channel 2	3	Output Channel 3
4	Field Power (+24Vdc)	5	Field Power (+24Vdc)
6	Field Power (+24Vdc)	7	Field Power (+24Vdc)

Specification

The following table describes the Output Specifications and the General Specifications for ST-2514.

Table 67: ST-2514: Output and General Specifications

Items	Specification
Output Specification	
Outputs Per Module	4 Points, Negative Logic
Indicators	4 Green/Red Output States, 1 Green/Red RSTi Bus State
Output Voltage Range	24Vdc nominal, Minimum 11Vdc to Maximum 28.8Vdc
ON-state Voltage Drop	Maximum 0.5Vdc@25°C
ON-state Minimum Current	1mA Per Channel
OFF-State Leakage Current	Maximum 50uA
Output Signal Delay	OFF to ON: Maximum 0.3ms ON to OFF: Maximum 0.3ms
Output Current Rating	Maximum 2.0A Per Channel Maximum 8.0A All Common
Output Protection	Over Temperature Shutdown: Minimum 150°C Over Current Limit: Minimum 3.5A/Maximum 7A Per Channel Short Circuit: Protection ESD Protection: 16.5Kv
Common Type	4 Points/4COM (Single Common)
General Specification	
Power Dissipation	Maximum 45mA @ 5.0Vdc
Isolation	I/O to Logic: Photo coupler isolation
Field Power	Field Power: Non-isolation Supply Voltage: 24Vdc nominal Voltage Range: 11~28.8Vdc Power Dissipation: 5mA@28.8Vdc per Channel
Wiring	I/O Cable Maximum 2.0mm ² (AWG 14)
Weight	70g
Module Size	12mm x 99mm x 70mm
Environment Condition	See "Environmental Specifications" in Appendix A.

ST-2524

Interface and Data

The following illustration shows the interface design for ST-2524.

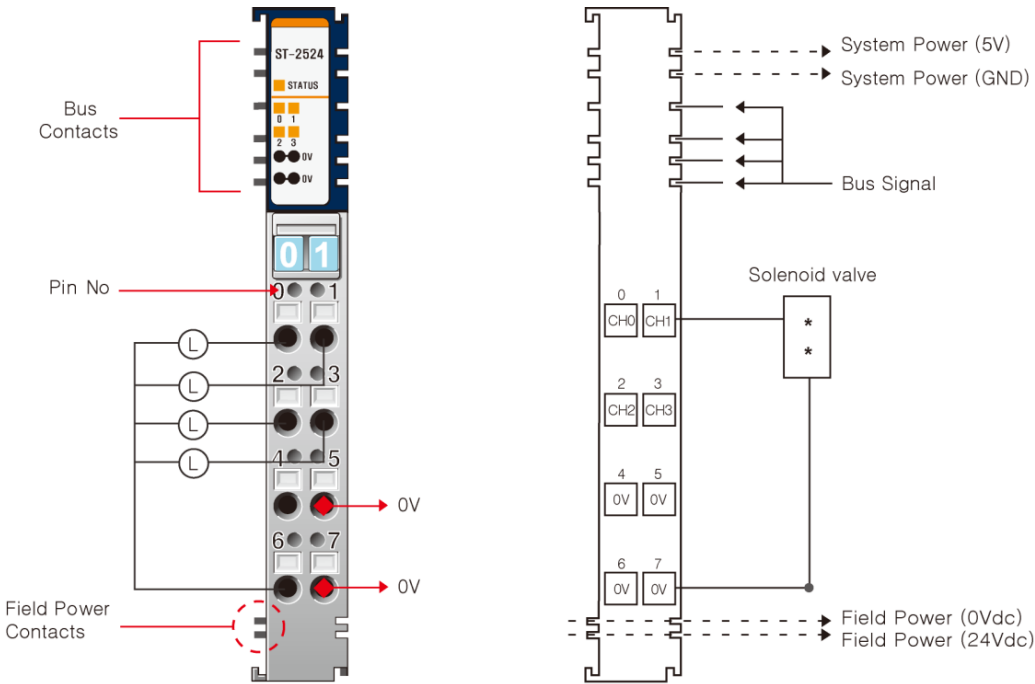

Figure 47: Discrete Output Module: ST-2524

The following table lists the pin numbers and description for ST-2524.

Table 68: ST-2524: Pin Description

<i>Pin Number</i>	<i>Description</i>	<i>Pin Number</i>	<i>Description</i>
0	Output Channel 0	1	Output Channel 1
2	Output Channel 2	3	Output Channel 3
4	Field Ground (0V)	5	Field Ground (0V)
6	Field Ground (0V)	7	Field Ground (0V)

Specification

The following table describes the Output Specifications and the General Specifications for ST-2524.

Table 69: ST-2524: Output and General Specifications

Items	Specification
Output Specification	
Outputs Per Module	4 Points, Positive Logic
Indicators	4 Green/Red Output States, 1 Green/Red RSTi Bus State
Output Voltage Range	24Vdc nominal, Minimum 11Vdc to Maximum 28.8Vdc
ON-state Voltage Drop	Maximum 0.5Vdc@25°C
ON-state Minimum Current	1mA Per Channel
OFF-State Leakage Current	Maximum 50uA
Output Signal Delay	OFF to ON: Maximum 0.3ms ON to OFF: Maximum 0.3ms
Output Current Rating	Maximum 2.0A Per Channel Maximum 8.0A All Common
Output Protection	Over Temperature Shutdown: Minimum 150°C Over Current Limit: Minimum 3.5A/Maximum 7A Per Channel Short Circuit: Protection ESD Protection: 16.5Kv
Common Type	4 Points/4COM (Single Common)
General Specification	
Power Dissipation	Maximum 45mA @ 5.0Vdc
Isolation	I/O to Logic: Photo coupler isolation Field Power: Non-isolation
Field Power	Supply Voltage: 24Vdc nominal Voltage Range: 11~28.8Vdc Power Dissipation: 5mA@28.8Vdc per Channel
Wiring	I/O Cable Maximum 2.0mm ² (AWG 14)
Weight	70g
Module Size	12mm x 99mm x 70mm
Environment Condition	See "Environmental Specifications" in Appendix A.

ST-2318

Interface and Data

The following illustration shows the interface design for ST-2318.

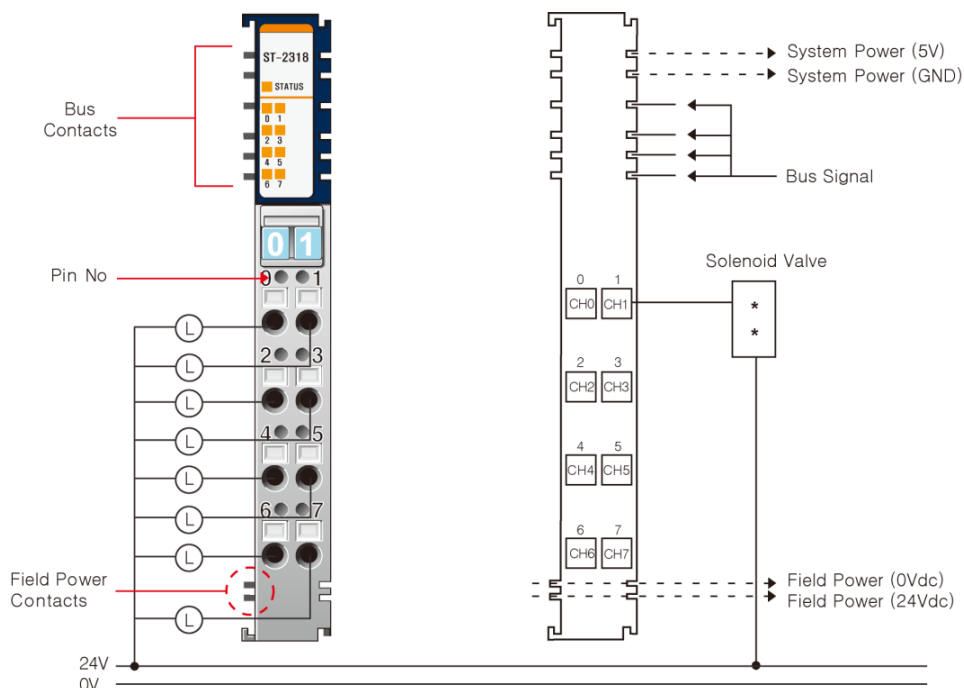

Figure 48: Discrete Output Module: ST-2318

The following table lists the pin numbers and description for ST-2318.

Table 70: ST-2318: Pin Description

Pin Number	Description	Pin Number	Description
0	Output Channel 0	1	Output Channel 1
2	Output Channel 2	3	Output Channel 3
4	Output Channel 4	5	Output Channel 5
6	Output Channel 6	7	Output Channel 7

Specification

The following table describes the Output Specifications and the General Specifications for ST-2318.

Table 71: ST-2318: Output and General Specifications

Items	Specification
Output Specification	
Outputs Per Module	8 Points Negative Logic
Indicators	8 Green Output States, 1 Green/Red RSTi Bus State
Output Voltage Range	24Vdc nominal, Minimum 11Vdc to Maximum 28.8Vdc
ON-state Voltage Drop	Maximum 0.3Vdc@25°C
ON-state Minimum Current	1mA Per Channel
OFF-State Leakage Current	Maximum 50uA
Output Signal Delay	OFF to ON: Maximum 0.3ms ON to OFF: Maximum 0.3ms
Output Current Rating	Maximum 0.5A Per Channel Maximum 4.0A All Unit
Output Protection	Over Temperature Shutdown: Minimum 150°C Over Current Limit: Minimum 3.5A/Maximum 7A Per Channel Short Circuit Protection ESD Protection: 16.5Kv
Common Type	8 Points/External Common
General Specification	
Power Dissipation	Maximum 60mA @ 5.0Vdc
Isolation	I/O to Logic: Photo coupler isolation Field Power: Non-isolation
Field Power	Supply Voltage: 24Vdc nominal Voltage Range: 11~28.8Vdc Power Dissipation: 5mA@28.8Vdc per Channel
Wiring	I/O Cable Maximum 2.0mm ² (AWG 14)
Weight	70g
Module Size	12mm x 99mm x 70mm
Environment Condition	See "Environmental Specifications" in Appendix A.

ST-2328

Interface and Data

The following illustration shows the interface design for ST-2328.

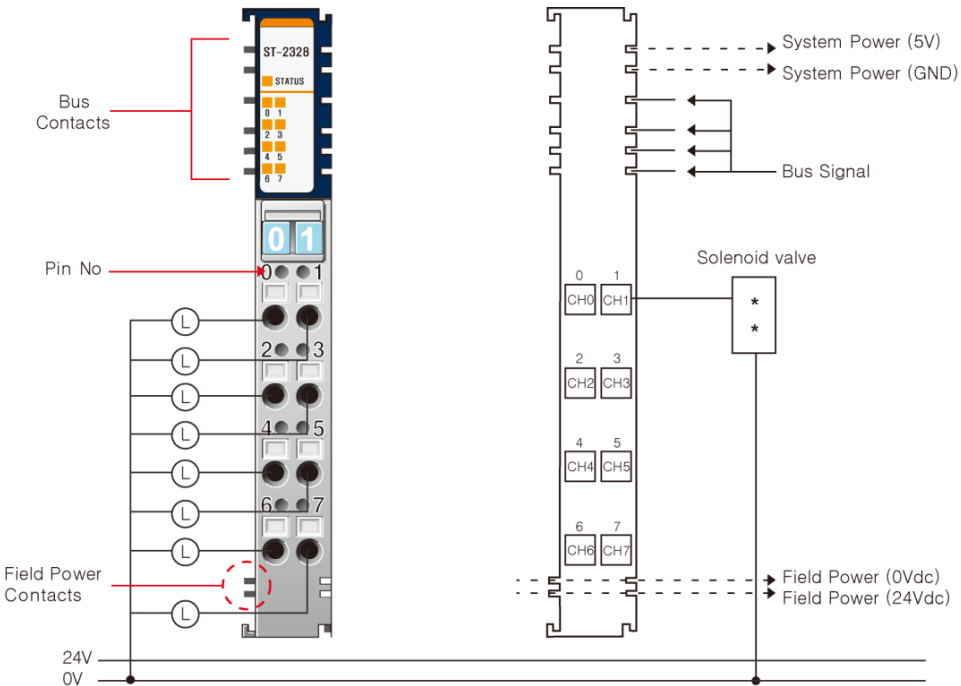

Figure 49: Discrete Output Module: ST-2328

The following table lists the pin numbers and description for ST-2328.

Table 72: ST-2328: Pin Description

Pin Number	Description	Pin Number	Description
0	Output Channel 0	1	Output Channel 1
2	Output Channel 2	3	Output Channel 3
4	Output Channel 4	5	Output Channel 5
6	Output Channel 6	7	Output Channel 7

Specification

The following table describes the Output Specifications and the General Specifications for ST-2328.

Table 73: ST-2328: Output and General Specifications

Items	Specification
Output Specification	
Outputs Per Module	8 Points, Positive Logic
Indicators	8 Green Output States, 1 Green/Red RSTi Bus State
Output Voltage Range	24Vdc nominal, Minimum 11Vdc to Maximum 28.8Vdc
ON-state Voltage Drop	Maximum 0.3Vdc@25°C
ON-state Minimum Current	1mA Per Channel
OFF-State Leakage Current	Maximum 50uA
Output Signal Delay	OFF to ON: Maximum 0.3ms ON to OFF: Maximum 0.3ms
Output Current Rating	Maximum 0.5A Per Channel Maximum 4.0A All Unit
Output Protection	Over Temperature Shutdown: Minimum 150°C Over Current Limit: Minimum 3.5A/Maximum 7.5A Per Channel Short Circuit Protection ESD Protection: 5.0Kv
Common Type	4 Points/External Common
General Specification	
Power Dissipation	Maximum 60mA @ 5.0Vdc
Isolation	I/O to Logic: Photo coupler isolation Field Power: Non-isolation
Field Power	Supply Voltage: 24Vdc nominal Voltage Range: 11~28.8Vdc Power Dissipation: 5mA@28.8Vdc per Channel
Wiring	I/O Cable Maximum 2.0mm ² (AWG 14)
Weight	70g
Module Size	12mm x 99mm x 70mm
Environment Condition	See "Environmental Specifications" in Appendix A.

ST-221F

Interface and Data

The following snapshot details the interface design for ST-221F.

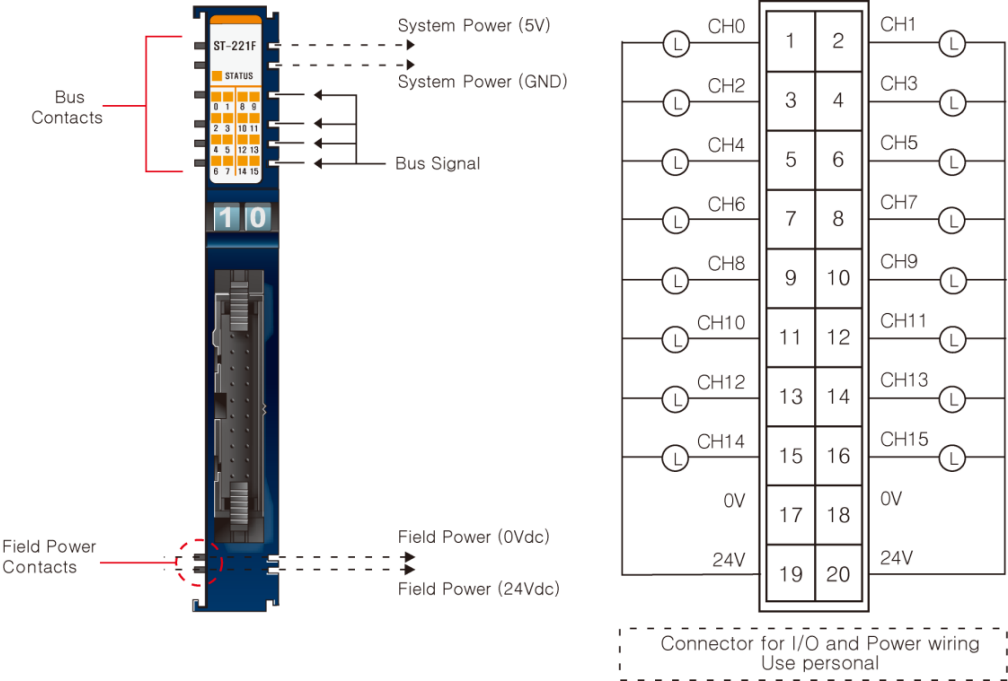

Figure 50: Discrete Output Module: ST-221F

The following table lists the pin numbers and description for ST-221F.

Table 74: ST-221F: Pin Description

<i>Pin Number</i>	<i>Description</i>	<i>Pin Number</i>	<i>Description</i>
1	Output Channel 0	2	Output Channel 1
3	Output Channel 2	4	Output Channel 3
5	Output Channel 4	6	Output Channel 5
7	Output Channel 6	8	Output Channel 7
9	Output Channel 8	10	Output Channel 9
11	Output Channel 10	12	Output Channel 11
13	Output Channel 12	14	Output Channel 13
15	Output Channel 14	16	Output Channel 15
17	Field Ground (0V)	18	Field Ground (0V)
19	Field Power (+24Vdc)	20	Field Power (+24Vdc)

Specification

The following table describes the Output Specifications and the General Specifications for ST-221F.

Table 75: ST-221F: Output and General Specifications

Items	Specification
Output Specification	
Outputs Per Module	16 Points, Negative Logic
Indicators	4 Green Output States, 1 Green/Red RSTi Bus State
Output Voltage Range	5Vdc nominal, Minimum 4.5Vdc to Maximum 5.5Vdc
ON-state Voltage Drop	Maximum 0.3Vdc@25°C
ON-state Minimum Current	1mA Per Channel
OFF-State Leakage Current	Maximum 50uA
Output Signal Delay	OFF to ON: Maximum 0.3ms ON to OFF: Maximum 0.3ms
Output Current Rating	Maximum 0.5A Per Channel Maximum 4.0A All Common
Output Protection	Over Temperature Shutdown: Minimum 150°C Over Current Limit: Minimum 3.5A/Maximum 7A Per Channel Short Circuit Protection ESD Protection: 16.5Kv
Common Type	16 Points/2COM (Single Common)
General Specification	
Power Dissipation	Maximum 80mA @ 5.0Vdc
Isolation	I/O to Logic: Photo coupler isolation Field Power: Non-isolation
Field Power	Supply Voltage: 24Vdc nominal Voltage Range: 11~28.8Vdc Power Dissipation: 3mA@28.8Vdc per Channel
Wiring	Connector Type
Weight	70g
Module Size	12mm x 99mm x 70mm
Environment Condition	See "Environmental Specifications" in Appendix A.

ST-222F

Interface and Data

The following illustration shows the interface design for ST-222F.

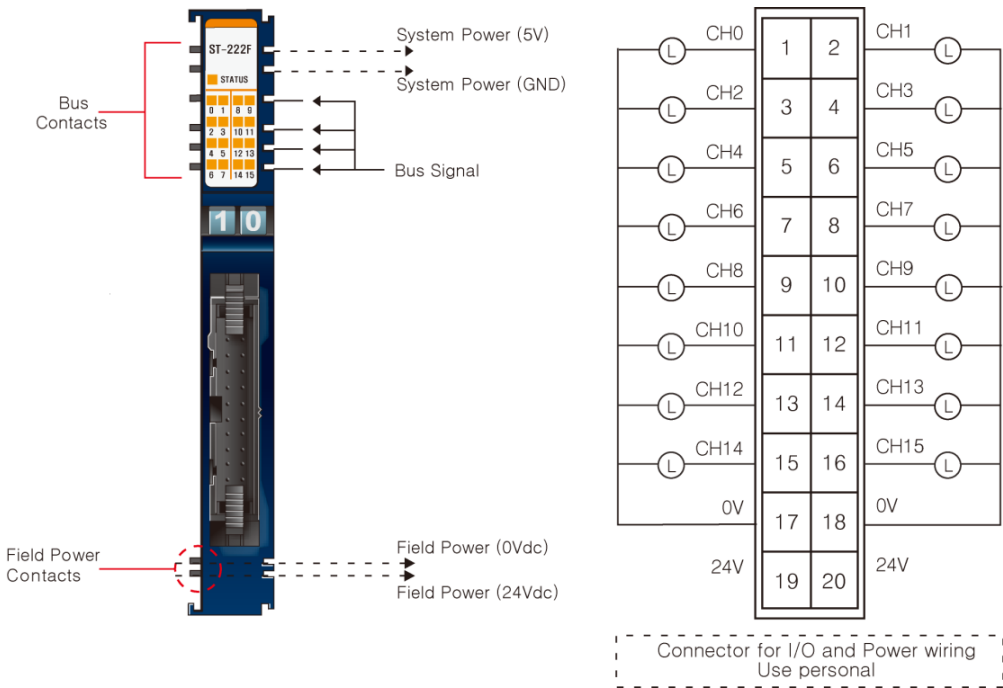

Figure 51: Discrete Output Module: ST-222F

The following table lists the pin numbers and description for ST-222F.

Table 76: ST-222F: Pin Description

Pin Number	Description	Pin Number	Description
1	Output Channel 0	2	Output Channel 1
3	Output Channel 2	4	Output Channel 3
5	Output Channel 4	6	Output Channel 5
7	Output Channel 6	8	Output Channel 7
9	Output Channel 8	10	Output Channel 9
11	Output Channel 10	12	Output Channel 11
13	Output Channel 12	14	Output Channel 13
15	Output Channel 14	16	Output Channel 15
17	Field Ground(0V)	18	Field Ground(0V)
19	Field Power (+24Vdc)	20	Field Power (+24Vdc)

Specification

The following table describes the Output Specifications and the General Specifications for ST-222F.

Table 77: ST-222F: Output and General Specifications

Items	Specification
Output Specification	
Outputs Per Module	16 Points, Positive Logic
Indicators	16 Green Output States, 1 Green/Red RSTi Bus State
Output Voltage Range	24Vdc nominal, Minimum 11Vdc to Maximum 28.8Vdc
ON-state Voltage Drop	Maximum 0.3Vdc@25°C
ON-state Minimum Current	1mA Per Channel
OFF-State Leakage Current	Maximum 50uA
Output Signal Delay	OFF to ON: Maximum 0.3ms ON to OFF: Maximum 0.3ms
Output Current Rating	Maximum 0.5A Per Channel Maximum 4.0A All Common
Output Protection	Over Temperature Shutdown: Minimum 150°C Over Current Limit: Minimum 3.5A/Maximum 7.5A Per Channel Short Circuit Protection ESD Protection: 5Kv
Common Type	16 Points/2COM (Single Common)
General Specification	
Power Dissipation	Maximum 80mA @ 5.0Vdc
Isolation	I/O to Logic: Photo coupler isolation
Field Power	Field Power: Non-isolation Supply Voltage: 24Vdc nominal Voltage Range: 11~28.8Vdc Power Dissipation: 5mA@28.8Vdc per Channel
Wiring	Connector Type
Weight	70g
Module Size	12mm x 99mm x 70mm
Environment Condition	See "Environmental Specifications" in Appendix A.

ST-2742

Interface and Data

The following illustration shows the interface design for ST-2742.

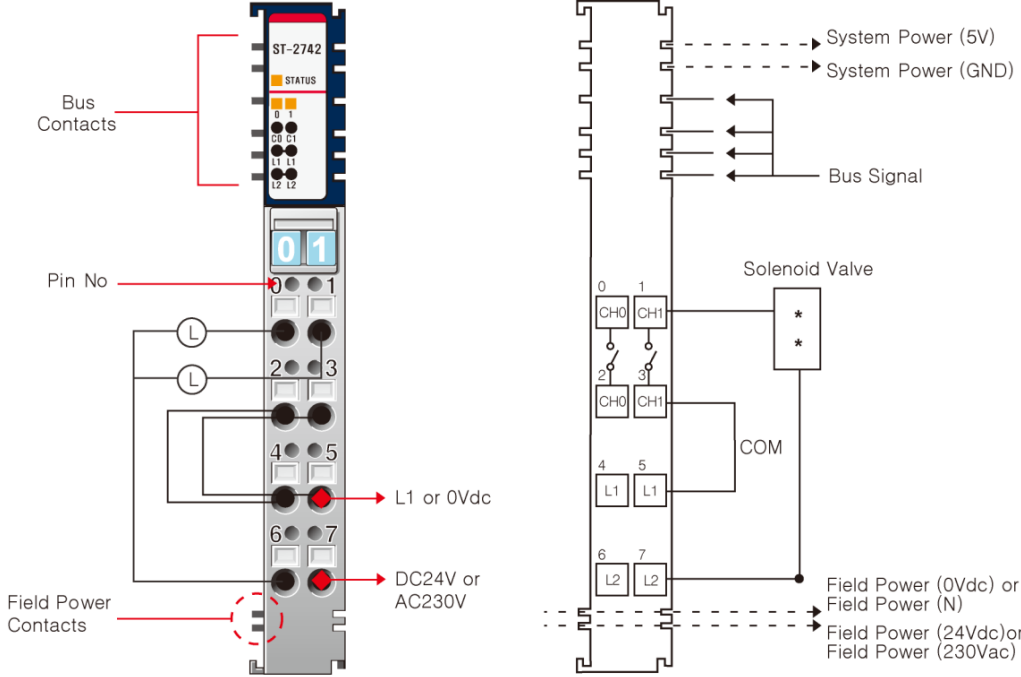

Figure 52: Discrete Output Module: ST-2742

The following table lists the pin numbers and description for ST-2742.

Table 78: ST-2742: Pin Description

Pin Number	Description	Pin Number	Description
0	Relay Output Channel 0_A	1	Relay Output Channel 1_A
2	Relay Output Channel 0_B	3	Relay Output Channel 1_B
4	L1/N/Field Ground (0Vdc)	5	L1/N/Field Ground (0Vdc)
6	L2 Output Field Power (24Vdc/240Vac)	7	L2 Output Field Power (24Vdc/240Vac)

Specification

The following table describes the Output Specifications and the General Specifications for ST-2742.

Table 79: ST-2742: Output and General Specifications

Items	Specification
Output Specification	
Outputs Per Module	2 Points
Indicators	2 Green Output States, 1 Green/Red RSTi Bus State
Relay type	Form A, normally Open (N.O.) Single Pole, Single Throw(SPST)
Output Voltage Range (Load Dependent)	5~28.8Vdc @ 2.0A Resistive 48Vdc @ 0.8A Resistive 110Vdc @ 0.5A Resistive 240Vac @ 2.0A Resistive
Output Current Rating (at rated power)	2A @ 5~28.8Vdc 0.8A @ 48Vdc 0.5A @ 110Vdc 2A @ 250Vac
Minimum Load	100uA, 100mVdc Per Point
Maximum On-state Voltage Drop	0.5V @ 2.0A, Resistive Load, 24Vdc
Off-State Leakage Current	Maximum 1.5mA
Output Signal Delay	On to Off: Maximum 10ms, Off to On: Maximum 10ms
Initial Contact Res.	30mΩ
Expected Contact Resistance	300K Cycles Resistive
Common Type	1 Points/1 COM
General Specification	
Power Dissipation	Maximum 65mA @ 5.0Vdc
Isolation	Field Power: Non-isolation
Field Power	Supply Voltage: 24Vdc, 240Vac Voltage Range: Minimum10Vdc to Maximum28.8Vdc Power Dissipation: 5mA@28.8Vdc per Channel
Wiring	I/O Cable Maximum 2.0mm ² (AWG 14)
Weight	65g
Environment Condition	See "Environmental Specifications" in Appendix A.

ST-2744

Interface and Data

The following illustration shows the interface design for ST-2744.

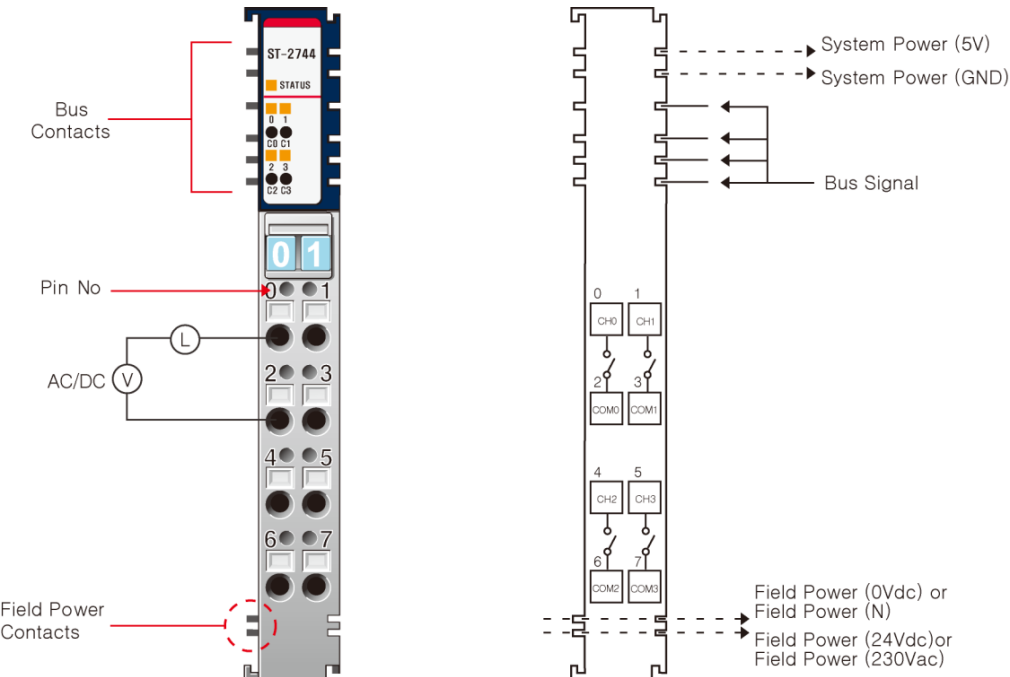

Figure 53: Discrete Output Module: ST-2744

The following table lists the pin numbers and description for ST-2744.

Table 80: ST-2744: Pin Description

Pin Number	Description	Pin Number	Description
0	Output Channel 0_A	1	Output Channel 1_A
2	COM 0	3	COM 1
4	Output Channel 2_A	5	Output Channel 3_A
6	COM 2	7	COM 3

Specification

The following table describes the Output Specifications and the General Specifications for ST-2744.

Table 81: ST-2744: Output and General Specifications

Items	Specification
Output Specification	
Outputs Per Module	4 Points
Indicators	4 Green Output States, 1 Green/Red RSTi Bus State
Relay type	Form A, normally Open (N.O.) Single Pole, Single Throw(SPST)
Output Range	5~28.8Vdc @ 2.0A Resistive 48Vdc @ 0.8A Resistive 110Vdc @ 0.5A Resistive 240Vac @ 2.0A Resistive
Minimum Load	100uA, 100mVdc Per Point
Maximum On-state Voltage Drop	0.5V @ 2.0A, Resistive Load, 24Vdc
Off-State Leakage Current	Maximum 1.5mA
Output Delay Time	On to Off: Maximum 10ms, Off to On: Maximum 10ms
Initial Contact Res.	20mΩ
Expected Contact Life	300K Cycles Resistive
Common Type	1 Points/1 COM (Single Common)
General Specification	
Power Dissipation	Maximum 130mA @ 5.0Vdc
Isolation	I/O to Logic: Relay Coil/Contact isolation 1250Vrms tested
Field Power	No Connection with Field Power Field Power passes through to the next module
Wiring	I/O Cable Maximum 2.0mm ² (AWG 14)
Weight	70g
Module Size	12mm x 99mm x 70mm
Environment Condition	See "Environmental Specifications" in Appendix A.

ST-2748

Interface and Data

The following illustration shows the interface design for ST-2748.

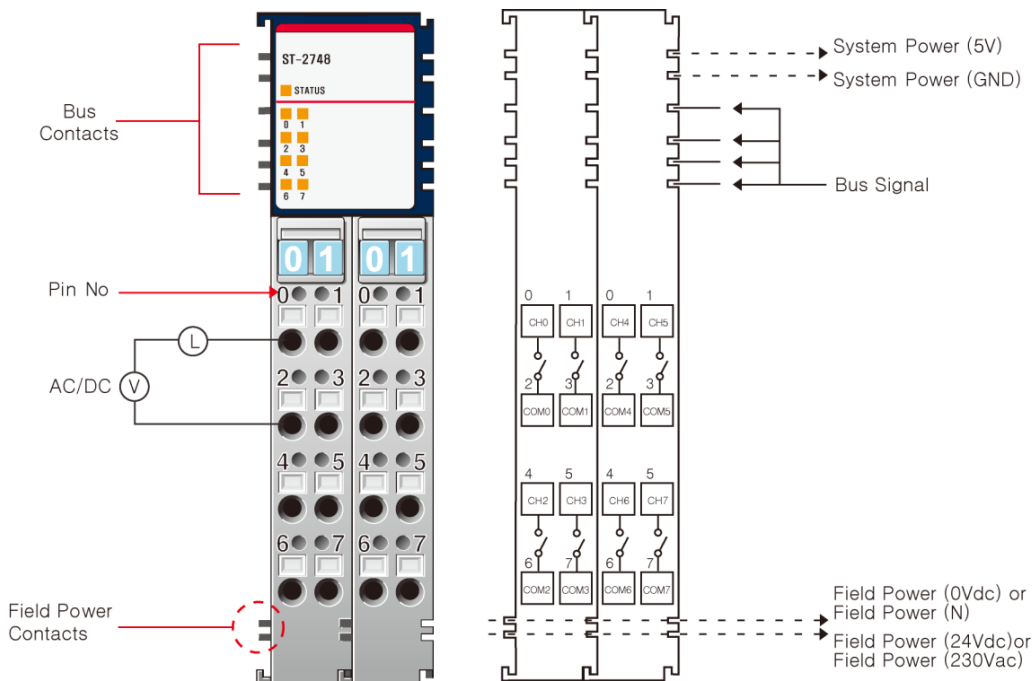

Figure 54: Discrete Output Module: ST-2748

Signal for Left Terminal

The following table lists the pin numbers and description for ST-2748 Left Terminal.

Table 82: ST-2748: Pin Description for Left Terminal

Pin Number	Description	Pin Number	Description
0	Output Channel 0_A	1	Output Channel 1_A
2	COM 0	3	COM 1
4	Output Channel 2_A	5	Output Channel 3_A
6	COM 2	7	COM 3

Signal for Right Terminal

The following table lists the pin numbers and its description for ST-2748 Right Terminal.

Table 83: ST-2748: Pin Description for Right Terminal

Pin Number	Description	Pin Number	Description
0	Output Channel 4_A	1	Output Channel 5_A
2	COM 4	3	COM 5

4	Output Channel 6_A	5	Output Channel 7_A
6	COM 6	7	COM 7

Specification

The following table describes the Output Specifications and the General Specifications for ST-2748.

Table 84: ST-2748: Output and General Specifications

Items	Specification
Output Specification	
Outputs Per Module	8 Points
Indicators	8 Green Output States, 1 Green/Red RSTi Bus State
Relay type	Form A, normally Open(N.O.) Single Pole, Single Throw(SPST)
Output Range	5~28.8Vdc @ 2.0A Resistive 48Vdc @ 0.8A Resistive 110Vdc @ 0.5A Resistive 240Vac @ 2.0A Resistive
Minimum Load	100uA, 100mVdc Per Point
Maximum On-state Voltage Drop	0.5V @ 2.0A, Resistive Load, 24Vdc
Off-State Leakage Current	Maximum 1.5mA
Output Delay Time	On to Off: Maximum 10ms, Off to On: Maximum 10ms
Initial Contact Res.	20mΩ
Expected Contact Life	300K Cycles Resistive
Common Type	1 Points/1 COM (Single Common)
General Specification	
Power Dissipation	Maximum 235mA @ 5.0Vdc
Isolation	I/O to Logic: Relay Coil/Contact isolation
Field Power	1250Vrms tested No Connection with Field Power, through Field Power passes to the next module
Wiring	I/O Cable Maximum 2.0mm ² (AWG 14)
Weight	200g
Module Size	12mm x 99mm x 70mm
Environment Condition	See "Environmental Specifications" in Appendix A.

ST-2852

Interface and Data

The following illustration shows the interface design for ST-2852.

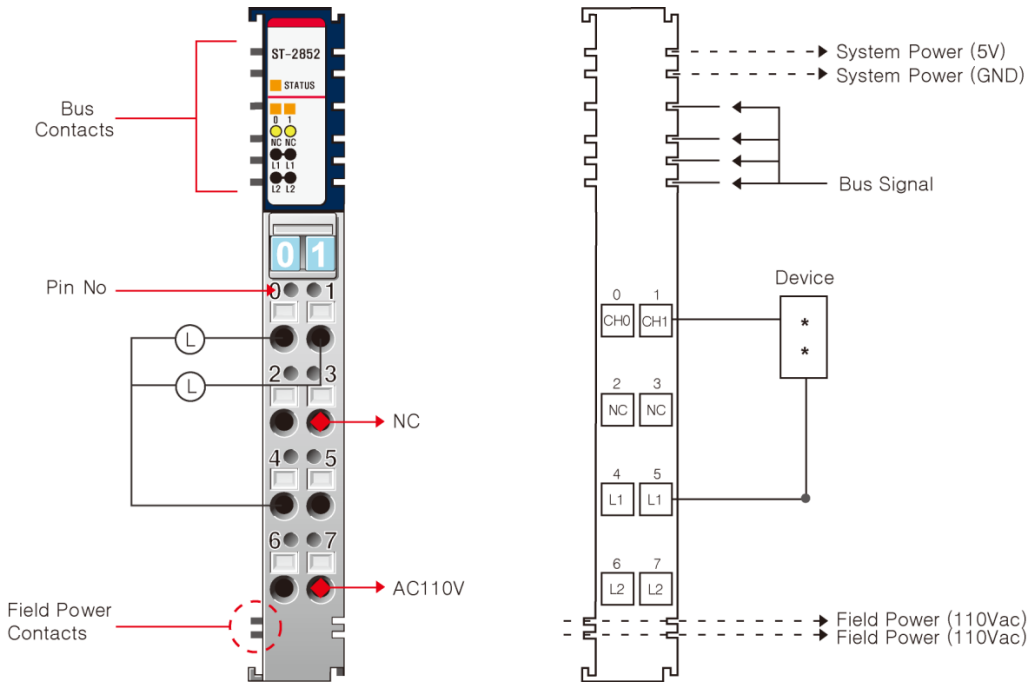

Figure 55: Discrete Output Module: ST-2852

The following table lists the pin numbers and description for ST-2852.

Table 85: ST-2852: Pin Description

Pin Number	Description	Pin Number	Description
0	Output Channel 0_A	1	Output Channel 1_A
2	NC	3	NC
4	L1 Output Field Power (110Vac)	5	L1 Output Field Power (110Vac)
6	L2 Output Field Power (110Vac)	7	L2 Output Field Power (110Vac)

Specification

The following table describes the Output Specifications and the General Specifications for ST-2852.

Table 86: ST-2852: Output and General Specifications

Items	Specification
Output Specification	
Outputs Per Module	2 Points
Indicators	2 Green Output Status, 1 Green/Red RSTi Bus State
Switch Type	Zero Crossing
Rated Load Voltage	15~132Vac
Output Current Rating	0.05~0.5A
Frequency Range	47~63Hz
Surge Current	40A (16mS)/4A(30S)
Output Signal Delay	OFF to ON: Maximum 0.3ms, ON to OFF: 1/ 2 Cycle + 0.3ms
On Status Voltage Drop	1.3Vrms (Maximum Load)
Off-state Leakage Current	Maximum 1.5mA
Common Type	2 Points/2 COM
General Specification	
Power Dissipation	Maximum 35mA @ 5.0Vdc
Isolation	Between user power and Systems
Field Power	Supply Voltage: 120Vac nominal Voltage Range: 12~125Vac
Wiring	I/O Cable Maximum 2.0mm ²
Weight	70g
Module Size	12mm x 99mm x 70mm
Environment Condition	See "Environmental Specifications" in Appendix A.

Dimension

ST-2xx2, ST-2xx4, ST-2xx8

The following illustration shows the dimensions for ST-2xx2, ST-2xx4, and ST-2xx8 series.

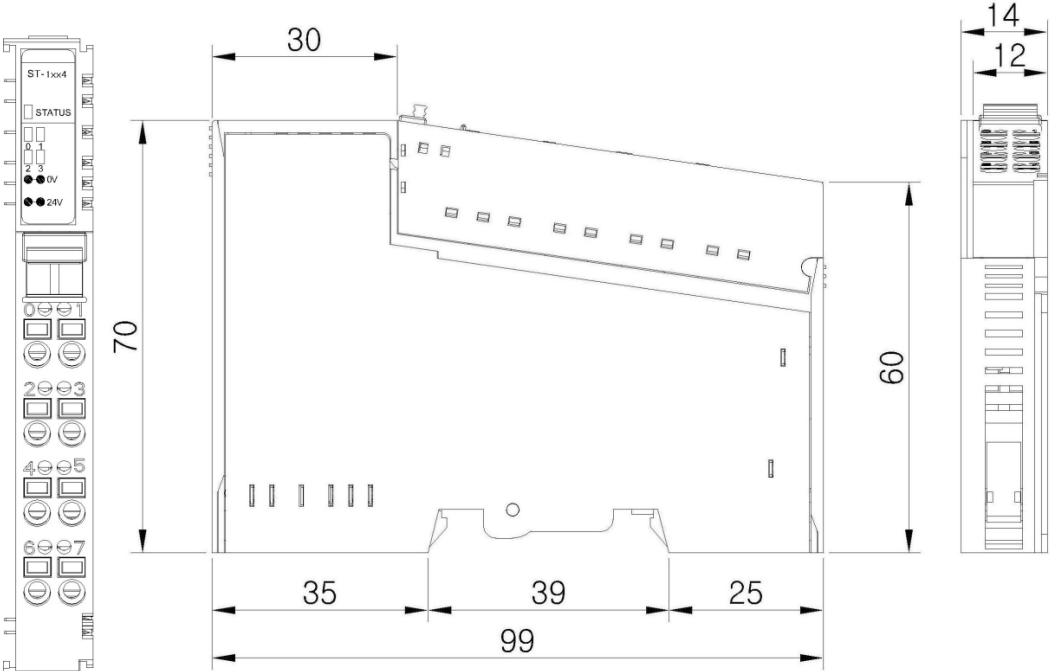

Figure 56: ST-2xx2, ST-2xx4, ST-2xx8 Dimensions

ST-2xxF

The following illustration shows the dimensions for ST-2xxF series.

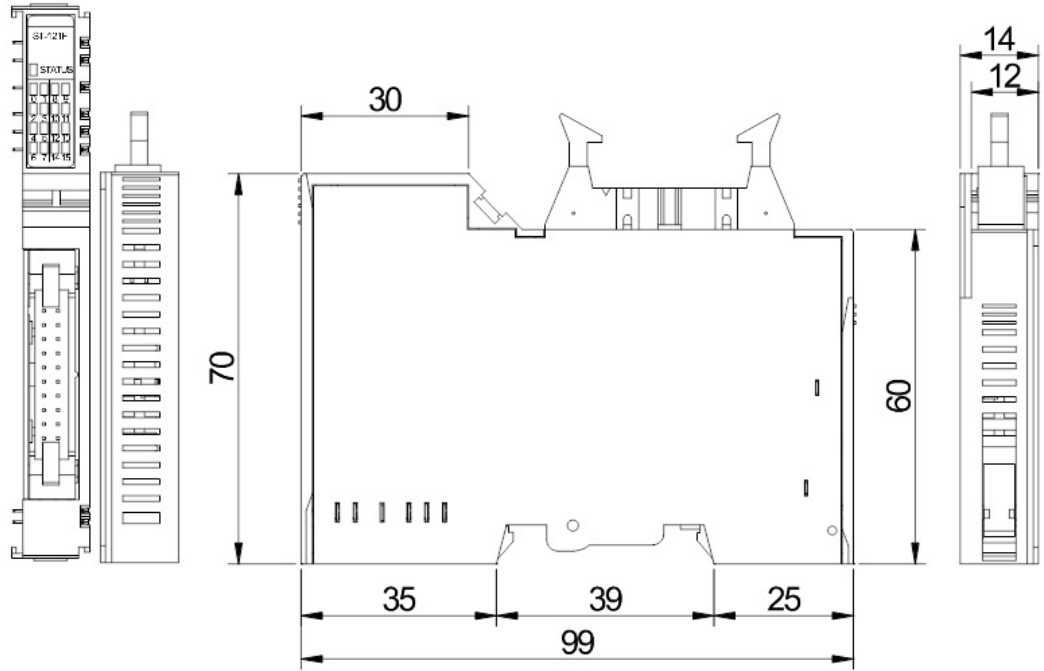

Figure 57: ST-2xxF Dimension

Mapping Data into the Image Table

ST-2742, ST-2852

Output Image Value

Bit No	Bit 7	Bit 6	Bit 5	Bit 4	Bit 3	Bit 2	Bit 1	Bit 0
Byte 0	Reserved						D1	D0



Output Module Data

D1	D0
----	----

ST-2xx4

Output Image Value

Bit No	Bit 7	Bit 6	Bit 5	Bit 4	Bit 3	Bit 2	Bit 1	Bit 0
Byte 0	Reserved				D3	D2	D1	D0



Output Module Data

D3	D2	D1	D0
----	----	----	----

ST-2xx8

Output Image value

Bit No	Bit 7	Bit 6	Bit 5	Bit 4	Bit 3	Bit 2	Bit 1	Bit 0
Byte 0	D7	D6	D5	D4	D3	D2	D1	D0



Output Module Data

D7	D6	D5	D4	D3	D2	D1	D0
----	----	----	----	----	----	----	----

ST-2xxF

Output Image value

Bit No	Bit 7	Bit 6	Bit 5	Bit 4	Bit 3	Bit 2	Bit 1	Bit 0
Byte 0	D7	D6	D5	D4	D3	D2	D1	D0
Byte 1	D15	D14	D13	D12	D11	D10	D9	D8



Output Module Data

D7	D6	D5	D4	D3	D2	D1	D0
D15	D14	D13	D12	D11	D10	D9	D8

Chapter**6*****Analog Inputs***

Analog Input Modules are available with 12 bit and 14 bit input modules according to their input value based of 4/8 Channels. RTD and TC modules of 2 channels are also available.

ST-3114

The Interface and Data

The following illustration shows the interface design for ST-3114.

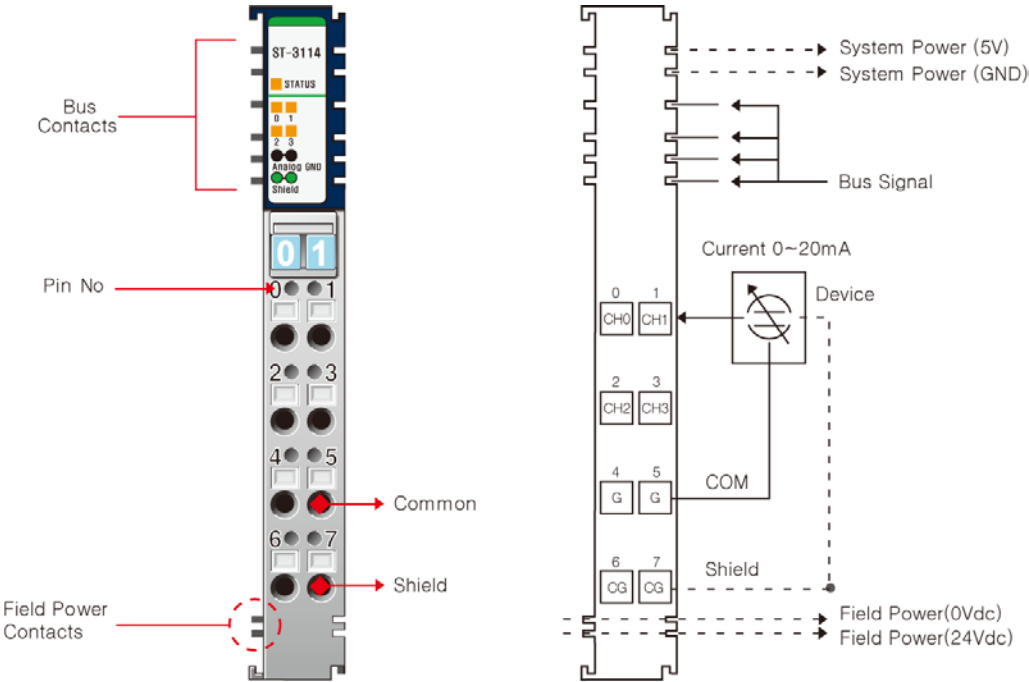

Figure 58: Analog Input Module: ST-3114

The following table lists the pin numbers and their description for ST-3114.

Table 87: ST-3114: Pin Description

Pin Number	Description	Pin Number	Description
0	Input Channel 0	1	Input Channel 1
2	Input Channel 2	3	Input Channel 3
4	Input Channel Common (0V)	5	Input Channel Common (0V)
6	Chassis Ground/Shield	7	Chassis Ground/Shield

Specification

The following table describes the Input Specifications and the General Specifications for ST-3114.

Table 88: ST-3114: Input and General Specifications

Items	Specification
Input Specification	
Number of Inputs	4 Channels Single Ended, Non-isolated Between Channels
Indicators	4 Green/Red States, 1 Green/Red RSTi Bus State
Resolution in Ranges	12 Bits: 4.88uA/Bit
Input current Range	0 ~ 20mA
Data Format	16 bits Integer (2's compliment)
Module Error	±0.1% Full Scale @25°C ±0.3% Full Scale @0°C, 60°C
Input Impedance	120Ω
Conversion Time	4msec/All channel
Calibration	Not Required
Diagnostic	No
Common Type	4 Channels/2COM (Single Common)
General Specification	
Power Supply	From System Power DC/DC
Power Dissipation	Maximum 165mA @ 5.0Vdc
Isolation	I/O to Logic: Photo coupler isolation Field power: Not Connected
Wiring	I/O Cable Maximum 2.0mm ²
Weight	70g
Module Size	12mm x 99mm x 70mm
Environment Condition	See "Environmental Specifications" in Appendix A.

ST-3118

Interface and Data

The following illustration shows the interface design for ST-3118.

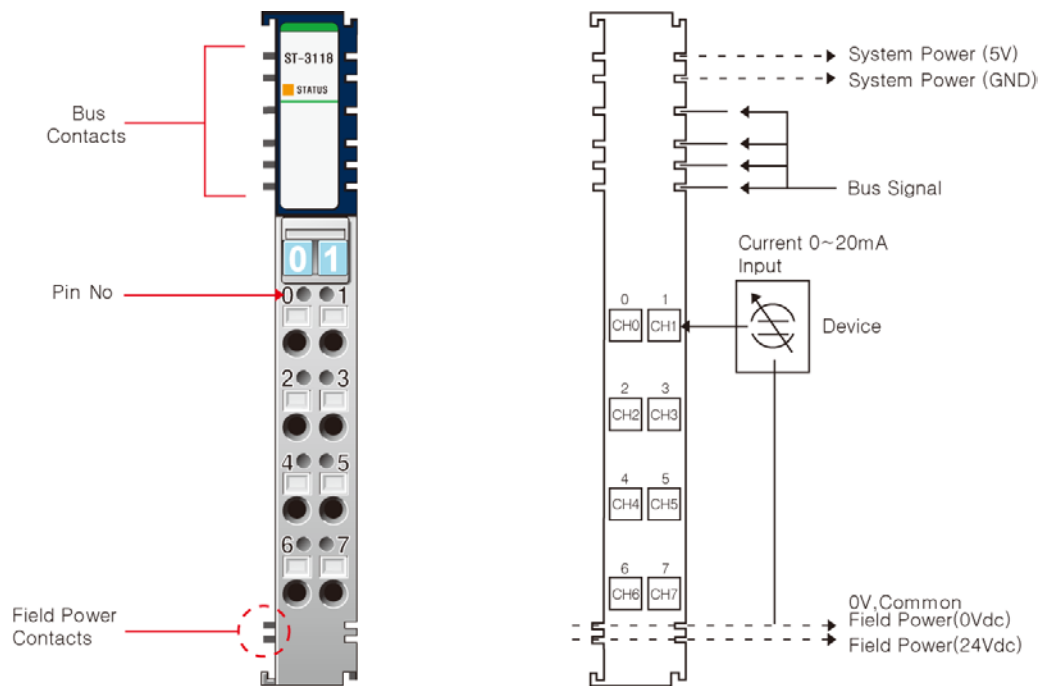

Figure 59: Analog Input Module: ST-3118

The following table lists the pin numbers and their description for ST-3118.

Table 89: ST-3118: Pin Description

Pin Number	Description	Pin Number	Description
0	Input Channel 0	1	Input Channel 1
2	Input Channel 2	3	Input Channel 3
4	Input Channel 4	5	Input Channel 5
6	Input Channel 6	7	Input Channel 7

Specification

The following table describes the Input Specifications and the General Specifications for ST-3118.

Table 90: ST-3118: Input and General Specifications

Items	Specification
Input Specification	
Number of Inputs	8 Channels Single Ended
Indicators	1 Green/Red RSTi Bus State
Resolution in Ranges	12 Bits: 4.88uA/Bit
Input current Range	0 ~ 20mA
Data Format	16 bits Integer (2's compliment)
Module Error	±0.1% Full Scale @25°C ±0.3% Full Scale @0°C, 60°C
Input Impedance	120Ω
Conversion Time	4msec/All channel
Calibration	Not Required
Diagnostic	No
Common Type	Nothing in the module terminal Field Power 0V is Common (AGND)
General Specification	
Power Dissipation	Maximum 80mA @ 5.0Vdc
Isolation	I/O to Logic: Photo coupler isolation I/O to Logic : Non-Isolation
Field Power	Supply Voltage : 24Vdc nominal Voltage Range : 18~28.8Vdc Power Dissipation: Maximum 40mA@24Vdc
Wiring	I/O Cable Maximum 2.0mm ² (AWG#14)
Weight	70g
Module Size	12mm x 99mm x 70mm
Environment Condition	See "Environmental Specifications" in Appendix A.

ST-3134

Interface and Data

The following illustration shows the interface design for ST-3134.

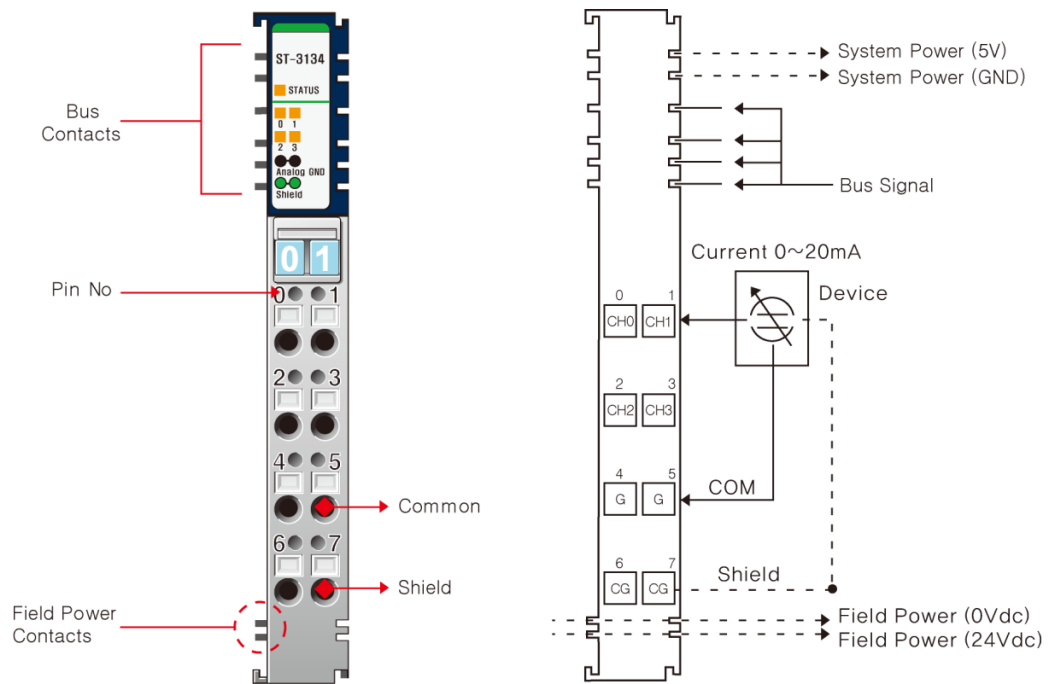

Figure 60: Analog Input Module: ST-3134

The following table lists the pin numbers and their description for ST-3134.

Table 91: ST-3134: Pin Description

Pin Number	Description	Pin Number	Description
0	Input Channel 0	1	Input Channel 1
2	Input Channel 2	3	Input Channel 3
4	Input Channel Common (0V)	5	Input Channel Common (0V)
6	Chassis Ground/Shield	7	Chassis Ground/Shield

Specification

The following table describes the Input Specifications and the General Specifications for ST-3134.

Table 92: ST-3134: Input and General Specifications

Items	Specification
Input Specification	
Number of Inputs	4 Channels Single Ended, Non-isolated Between Channels
Indicators	4 Green/Red States, 1 Green/Red RSTi Bus State
Resolution in Ranges	14 Bits: 1.22uA/Bit
Input current Range	0 ~ 20mA
Data Format	16 bits Integer (2's compliment)
Module Error	±0.1% Full Scale @25°C ±0.3% Full Scale @0°C, 60°C
Input Impedance	120Ω
Conversion Time	4msec/All channel
Calibration	Not Required
Diagnostic	No
Common Type	4 Channels/2COM (Single Common)
General Specification	
Power Supply	From System Power DC/DC
Power Dissipation	Maximum 165mA @ 5.0Vdc
Isolation	I/O to Logic: Photo coupler isolation Field Power: Not Connected
Wiring	I/O Cable Maximum 2.0mm ²
Weight	70g
Module Size	12mm x 99mm x 70mm
Environment Condition	See "Environmental Specifications" in Appendix A.

ST-3214

Interface and Data

The following illustration shows the interface design for ST-3214.

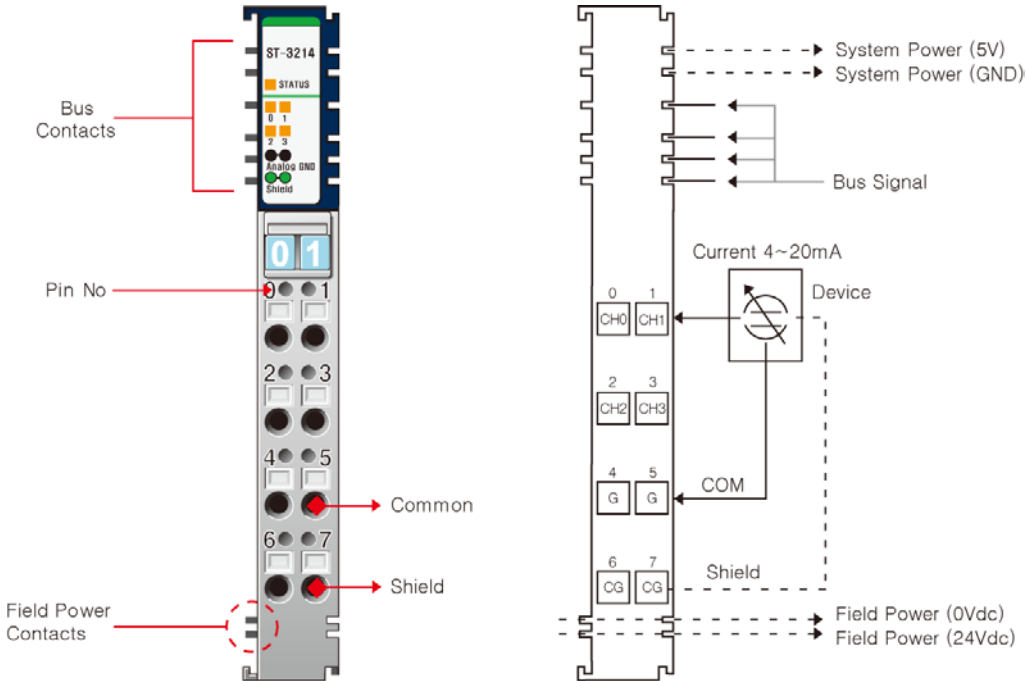

Figure 61: Analog Input Module: ST-3214

The following table lists the pin numbers and their description for ST-3214.

Table 93: ST-3214: Pin Description

<i>Pin Number</i>	<i>Description</i>	<i>Pin Number</i>	<i>Description</i>
0	Input Channel 0	1	Input Channel 1
2	Input Channel 2	3	Input Channel 3
4	Input Channel Common (0V)	5	Input Channel Common (0V)
6	Chassis Ground/Shield	7	Chassis Ground/Shield

Specification

The following table describes the Input Specifications and the General Specifications for ST-3214.

Table 94: ST-3214: Input and General Specifications

Items	Specification
Input Specification	
Number of Inputs	4 Channels Single Ended, Non-isolated Between Channels
Indicators	4 Green/Red States, 1 Green/Red RSTi Bus State
Resolution in Ranges	12 Bits: 3.9uA/Bit
Input current Range	4 ~ 20mA
Data Format	16 bits Integer (2's compliment)
Module Error	±0.1% Full Scale @25°C ±0.3% Full Scale @0°C, 60°C
Input Impedance	120Ω
Conversion Time	4msec/All channel
Calibration	Not Required
Diagnostic	Channel Open (if < 3mA, Data=0x8000)
Common Type	4 Channels/2COM (Single Common)
General Specification	
Power Supply	From System Power DC/DC
Power Dissipation	Maximum 165mA @ 5.0Vdc
Isolation	I/O to Logic: Photo coupler isolation Field Power : Not Connected
Wiring	I/O Cable Maximum 2.0mm ²
Weight	70g
Module Size	12mm x 99mm x 70mm
Environment Condition	See "Environmental Specifications" in Appendix A.

ST-3218

Interface and Data

The following illustration shows the interface design for ST-3218.

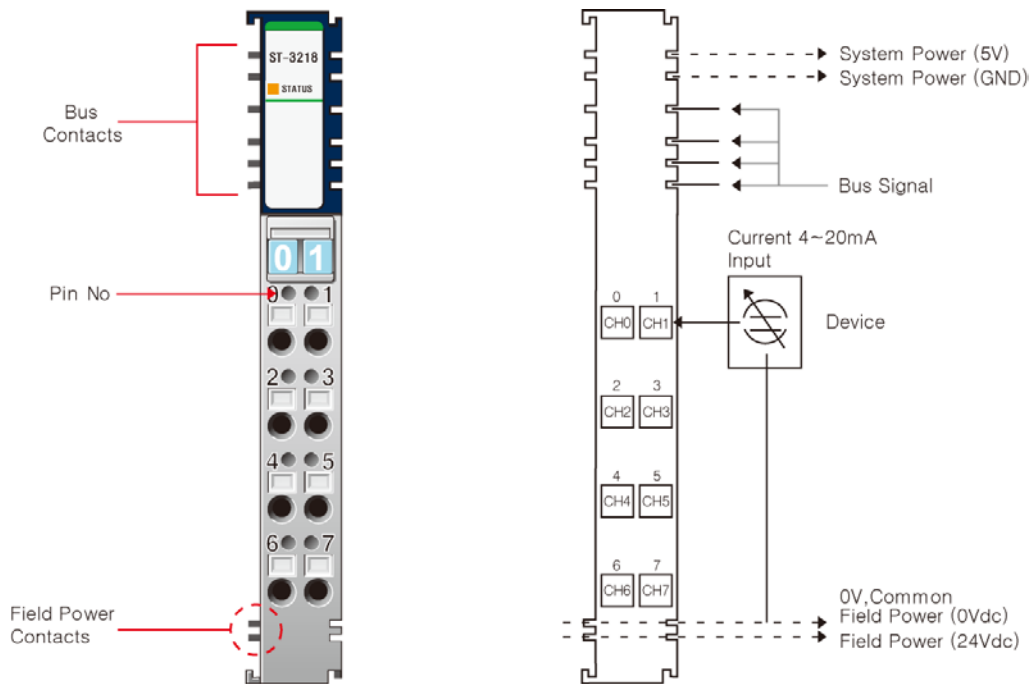

Figure 62: Analog Input Module: ST-3218

The following table lists the pin numbers and their description for ST-3218.

Table 95: ST-3218: Pin Description

Pin Number	Description	Pin Number	Description
0	Input Channel 0	1	Input Channel 1
2	Input Channel 2	3	Input Channel 3
4	Input Channel 4	5	Input Channel 5
6	Input Channel 6	7	Input Channel 7

Specification

The following table describes the Input Specifications and the General Specifications for ST-3218.

Table 96: ST-3218: Input and General Specifications

Items	Specification
Input Specification	
Number of Inputs	8 Channels Single Ended
Indicators	1 Green/Red RSTi Bus State
Resolution in Ranges	12Bits: 3.9uA/Bit
Input current Range	4 ~ 20mA
Data Format	16bits Integer (2's compliment)
Module Error	±0.1% Full Scale @25°C ±0.3% Full Scale @0°C, 60°C
Input Impedance	120Ω
Conversion Time	4msec/All channel
Calibration	Not Required
Diagnostic	No
Common Type	Nothing in the module terminal Field Power 0V is Common(AGND)
General Specification	
Power Dissipation	Maximum 80mA @ 5.0Vdc
Isolation	I/O to Logic: Photo coupler isolation I/O to Logic : Non-Isolation
Field Power	Supply Voltage: 24Vdc nominal Voltage Range: 18~28.8Vdc Power Dissipation: Maximum 40mA@24Vdc
Wiring	I/O Cable Maximum 2.0mm ² (AWG#14)
Weight	70g
Module Size	12mm x 99mm x 70mm
Environment Condition	See "Environmental Specifications" in Appendix A.

ST-3234

Interface and Data

The following illustration shows the interface design for ST-3234.

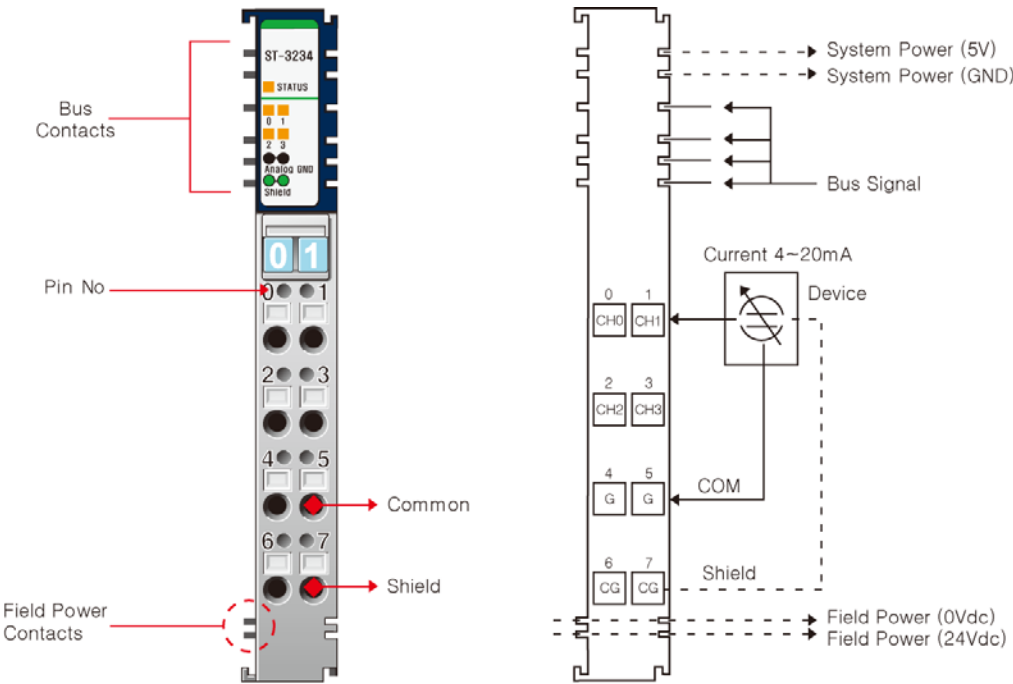

Figure 63: Analog Input Module: ST-3234

The following table lists the pin numbers and their description for ST-3234.

Table 97: ST-3234: Pin Description

Pin Number	Description	Pin Number	Description
0	Input Channel 0	1	Input Channel 1
2	Input Channel 2	3	Input Channel 3
4	Input Channel Common (0V)	5	Input Channel Common (0V)
6	Chassis Ground/Shield	7	Chassis Ground/Shield

Specification

The following table describes the Input Specifications and the General Specifications for ST-3234.

Table 98: ST-3234: Input and General Specifications

Items	Specification
Input Specification	
Number of Inputs	4 Channels Single Ended, Non-isolated Between Channels
Indicators	4 Green/Red States, 1 Green/Red RSTi Bus State
Resolution in Ranges	14 Bits: 0.9uA/Bit
Input current Range	4 ~ 20mA
Data Format	16 bits Integer (2's compliment)
Module Error	±0.1% Full Scale @25°C ±0.3% Full Scale @0°C, 60°C
Input Impedance	120Ω
Conversion Time	4msec/All channel
Calibration	Not Required
Diagnostic	Channel Open (if < 3mA, Data=0x8000)
Common Type	4 Channels/2COM (Single Common)
General Specification	
Power Supply	From System Power DC/DC
Power Dissipation	Maximum 165mA @ 5.0Vdc
Isolation	I/O to Logic: Photo coupler isolation Field power: Not Connected
Wiring	I/O Cable Maximum 2.0mm ²
Weight	70g
Module Size	12mm x 99mm x 70mm
Environment Condition	See "Environmental Specifications" in Appendix A.

ST-3424

Interface and Data

The following illustration shows the interface design for ST-3424.

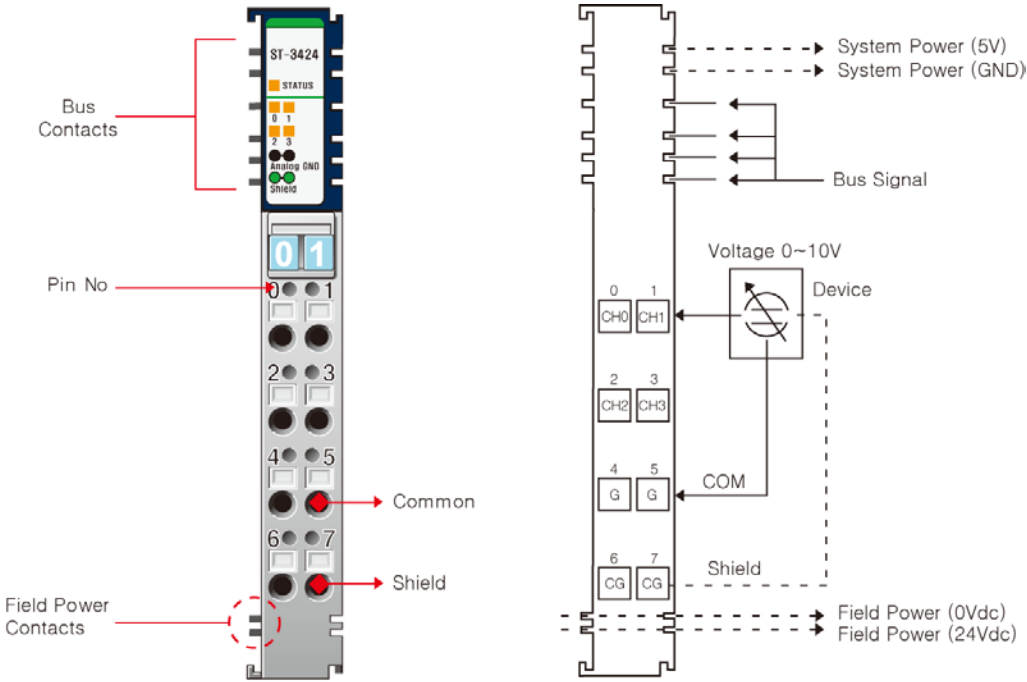

Figure 64: Analog Input Module: ST-3424

The following table lists the pin numbers and their description for ST-3424.

Table 99: ST-3424: Pin Description

Pin Number	Description	Pin Number	Description
0	Input Channel 0	1	Input Channel 1
2	Input Channel 2	3	Input Channel 3
4	Input Channel Common (0V)	5	Input Channel Common (0V)
6	Chassis Ground/Shield	7	Chassis Ground/Shield

Specification

The following table describes the Input Specifications and the General Specifications for ST-3424.

Table 100: ST-3424: Input and General Specifications

Items	Specification
Input Specification	
Number of Inputs	4 Channels Single Ended, Non-isolated Between Channels
Indicators	4 Green States, 1 Green/Red RSTi Bus State
Resolution in Ranges	12 Bits: 2.44mV/Bit
Input Voltage Range	0 ~ 10Vdc
Data Format	16 bits Integer (2's compliment)
Module Error	±0.1% Full Scale @25°C ±0.3% Full Scale @0°C, 60°C
Input Impedance	500KΩ
Conversion Time	4msec/All channel
Calibration	Not Required
Diagnostic	No
Common Type	4 Channels/2COM (Single Common)
General Specification	
Power Supply	From System Power DC/DC
Power Dissipation	Maximum 165mA @ 5.0Vdc
Isolation	I/O to Logic: Photo coupler isolation Field power: Not Connected
Wiring	I/O Cable Maximum 2.0mm ²
Weight	70g
Module Size	12mm x 99mm x 70mm
Environment Condition	See "Environmental Specifications" in Appendix A.

ST-3428

Interface and Data

The following illustration shows the interface design for ST-3428.

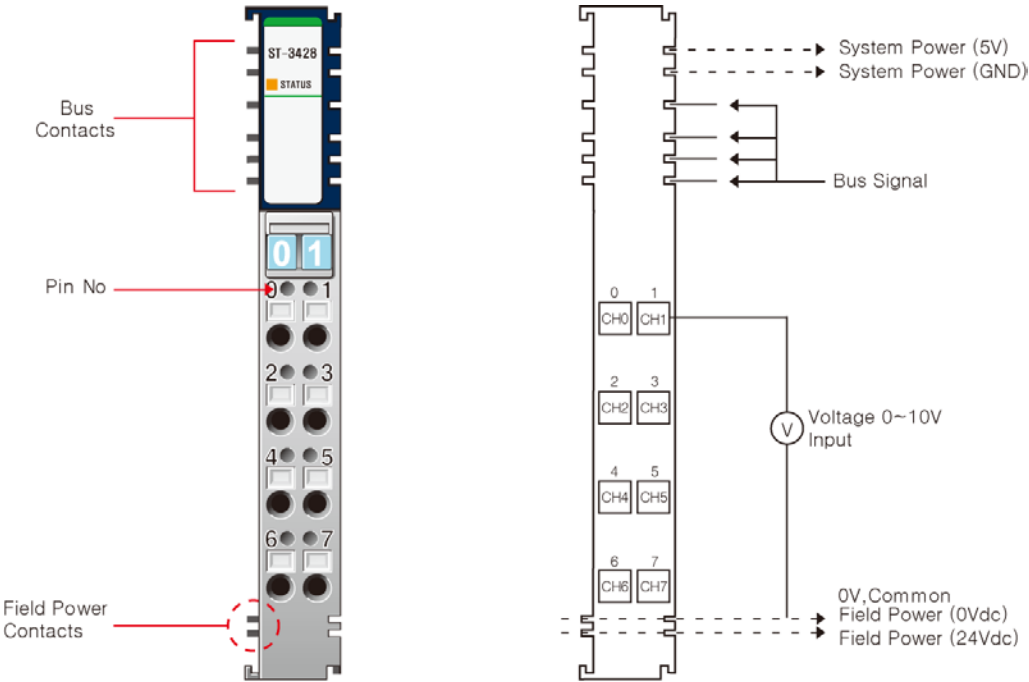

Figure 65: Analog Input Module: ST-3428

The following table lists the pin numbers and their description for ST-3428.

Table 101: ST-3428: Pin Description

Pin Number	Description	Pin Number	Description
0	Input Channel 0	1	Input Channel 1
2	Input Channel 2	3	Input Channel 3
4	Input Channel 4	5	Input Channel 5
6	Input Channel 6	7	Input Channel 7

Specification

The following table describes the Input Specifications and the General Specifications for ST-3428.

Table 102: ST-3428: Input and General Specifications

Items	Specification
Input Specification	
Number of Inputs	8 Channels Single Ended
Indicators	1 Green/Red RSTi Bus State
Resolution in Ranges	12 Bits: 2.44mV/Bit
Input Voltage Range	0 ~ 10Vdc
Data Format	16 bits Integer (2's compliment)
Module Error	±0.1% Full Scale @25°C ±0.3% Full Scale @0°C, 60°C
Input Impedance	500KΩ
Conversion Time	4msec/All channel
Calibration	Not Required
Diagnostic	No
Common Type	Nothing in the module terminal Field Power 0V is Common (AGND)
General Specification	
Power Dissipation	Maximum 80mA @ 5.0Vdc
Isolation	I/O to Logic: Photo coupler isolation Field Power: Non-Isolation
Field Power	Supply Voltage: 24Vdc nominal Voltage Range: 18~28.8Vdc Power Dissipation: Maximum 40mA@24Vdc
Wiring	I/O Cable Maximum 2.0mm ²
Weight	70g
Module Size	12mm x 99mm x 70mm
Environment Condition	See "Environmental Specifications" in Appendix A.

ST-3444

Interface and Data

The following illustration shows the interface design for ST-3444.

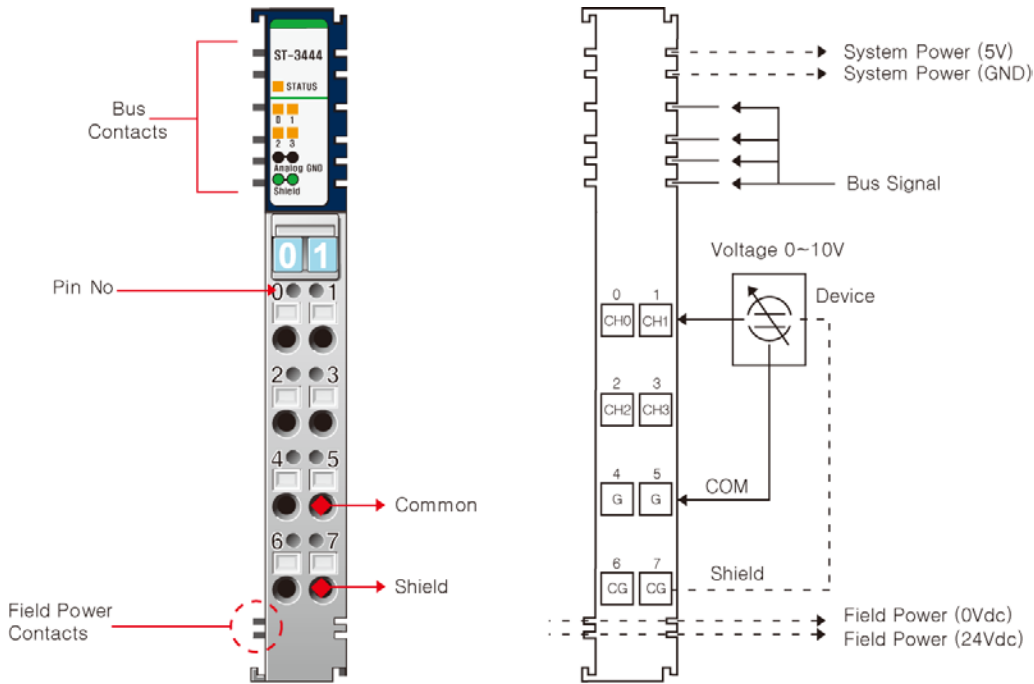

Figure 66: Analog Input Module: ST-3444

The following table lists the pin numbers and their description for ST-3444.

Table 103: ST-3444: Pin Description

Pin Number	Description	Pin Number	Description
0	Input Channel 0	1	Input Channel 1
2	Input Channel 2	3	Input Channel 3
4	Input Channel Common (0V)	5	Input Channel Common (0V)
6	Chassis Ground/Shield	7	Chassis Ground/Shield

Specification

The following table describes the Input Specifications and the General Specifications for ST-3444.

Table 104: ST-3444: Input and General Specifications

Items	Specification
Input Specification	
Number of Inputs	4 Channels Single Ended, Non-isolated Between Channels
Indicators	4 Green/Red States, 1 Green/Red RSTi Bus State
Resolution in Ranges	14 Bits : 0.6mV/Bit
Input Voltage Range	0 ~ 10Vdc
Data Format	16 bits Integer (2's compliment)
Module Error	±0.1% Full Scale @25°C ±0.3% Full Scale @0°C, 60°C
Input Impedance	500KΩ
Conversion Time	4msec/All channel
Calibration	Not Required
Diagnostic	No
Common Type	4 Channels/2COM (Single Common)
General Specification	
Power Supply	From System Power DC/DC
Power Dissipation	Maximum 170mA @ 5.0Vdc
Isolation	I/O to Logic: Photo coupler isolation Field power: Not Connected
Wiring	I/O Cable Maximum 2.0mm ²
Weight	70g
Module Size	12mm x 99mm x 70mm
Environment Condition	See "Environmental Specifications" in Appendix A.

ST-3524

Interface and Data

The following illustration shows the interface design for ST-3524.

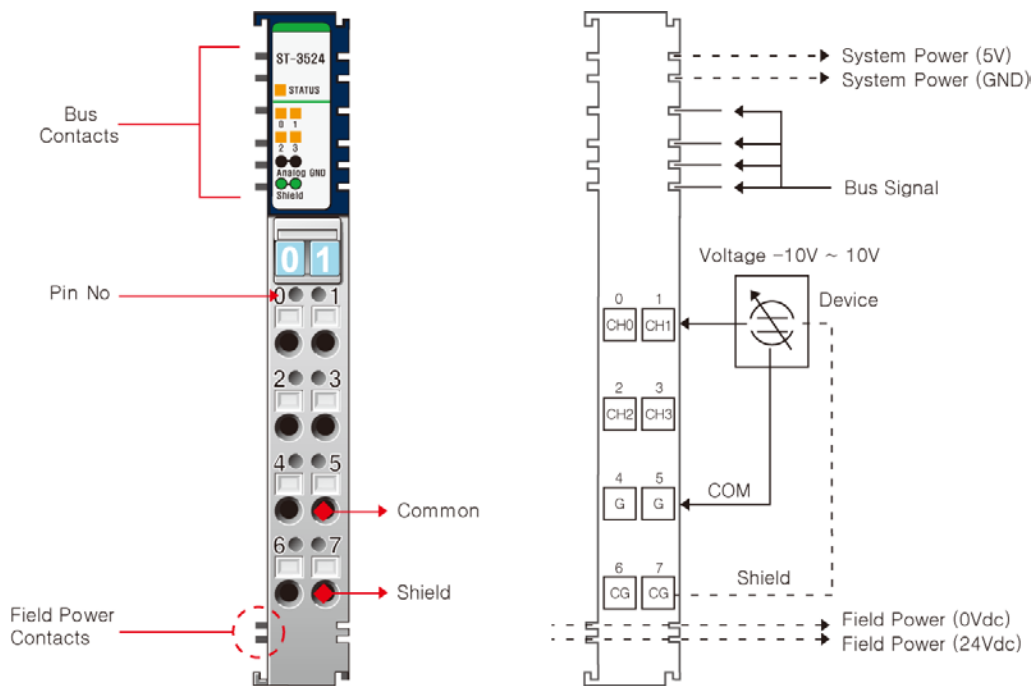

Figure 67: Analog Input Module: ST-3524

The following table lists the pin numbers and their description for ST-3524.

Table 105: ST-3524: Pin Description

Pin Number	Description	Pin Number	Description
0	Input Channel 0	1	Input Channel 1
2	Input Channel 2	3	Input Channel 3
4	Input Channel Common (0V)	5	Input Channel Common (0V)
6	Chassis Ground/Shield	7	Chassis Ground/Shield

Specification

The following table describes the Input Specifications and the General Specifications for ST-3524.

Table 106: ST-3524: Input and General Specifications

Items	Specification
Input Specification	
Number of Inputs	4 Channels Single Ended, Non-isolated Between Channels
Indicators	4 Green/Red States, 1 Green/Red RSTi Bus State
Resolution in Ranges	12 Bits: 4.8mV/Bit
Input Voltage Range	-10 ~ +10Vdc
Data Format	16 bits Integer (2's compliment)
Module Error	±0.1% Full Scale @25°C ±0.3% Full Scale @0°C, 60°C
Input Impedance	500KΩ
Conversion Time	4msec/All channel
Calibration	Not Required
Diagnostic	No
Common Type	4 Channels/2 COM (Single Common)
General Specification	
Power Supply	From System Power DC/DC
Power Dissipation	Maximum 170mA @ 5.0Vdc
Isolation	I/O to Logic: Photo coupler isolation Field power: Not Connected
Wiring	I/O Cable Maximum 2.0mm ²
Weight	70g
Module Size	12mm x 99mm x 70mm
Environment Condition	See "Environmental Specifications" in Appendix A.

ST-3544

Interface and Data

The following illustration shows the interface design for ST-3544.

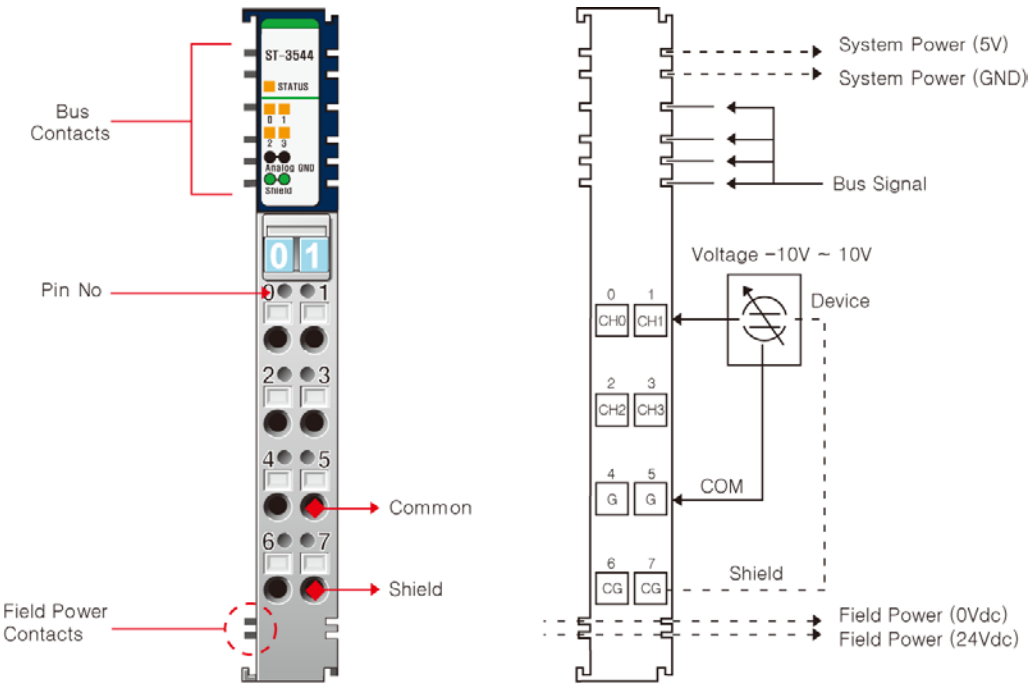

Figure 68: Analog Input Module: ST-3544

The following table lists the pin numbers and their description for ST-3544.

Table 107: ST-3544: Pin Description

Pin Number	Description	Pin Number	Description
0	Input Channel 0	1	Input Channel 1
2	Input Channel 2	3	Input Channel 3
4	Input Channel Common (0V)	5	Input Channel Common (0V)
6	Chassis Ground/Shield	7	Chassis Ground/Shield

Specification

The following table describes the Input Specifications and the General Specifications for ST-3544.

Table 108: ST-3544: Input and General Specifications

Items	Specification
Input Specification	
Number of Inputs	4 Channels Single Ended, Non-isolated Between Channels
Indicators	4 Green/Red States, 1 Green/Red RSTi Bus State
Resolution in Ranges	14 Bits: 1.2mV/Bit
Input Voltage Range	-10 ~ +10Vdc
Data Format	16 bits Integer (2's compliment)
Module Error	±0.1% Full Scale @25°C ±0.3% Full Scale @0°C, 60°C
Input Impedance	500KΩ
Conversion Time	4msec/All channel
Calibration	Not Required
Diagnostic	No
Common Type	4 Channels/2 COM (Single Common)
General Specification	
Power Supply	From System Power DC/DC
Power Dissipation	Maximum 200mA @ 5.0Vdc
Isolation	I/O to Logic: Photo coupler isolation Field power: Not Connected
Wiring	I/O Cable Maximum 2.0mm ²
Weight	70g
Module Size	12mm x 99mm x 70mm
Environment Condition	See "Environmental Specifications" in Appendix A.

ST-3624

Interface and Data

The following illustration shows the interface design for ST-3624.

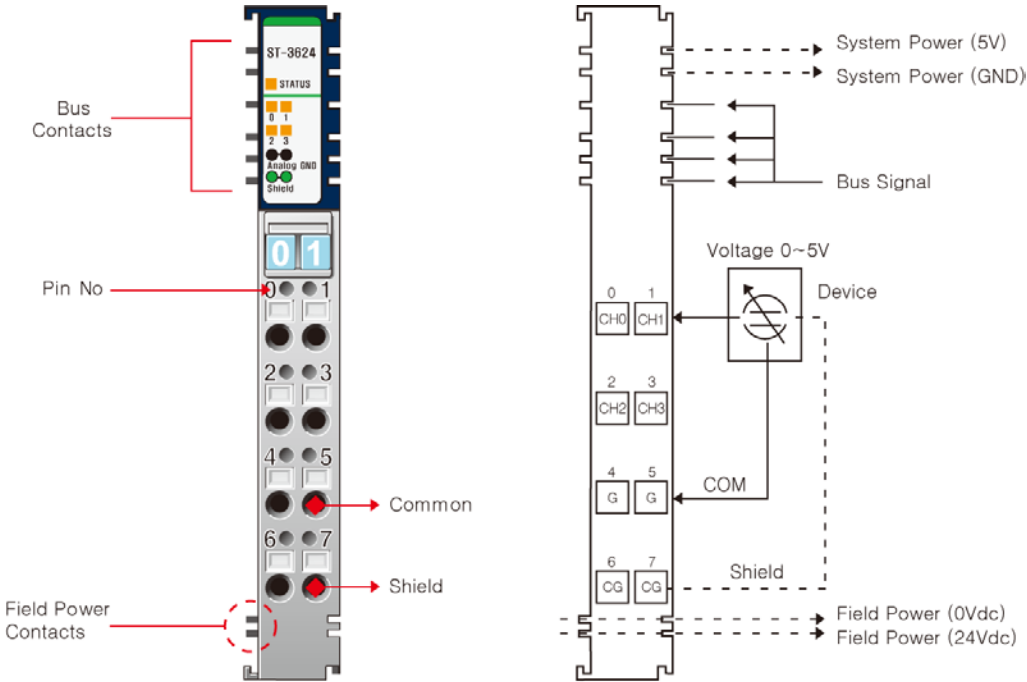

Figure 69: Analog Input Module: ST-3624

The following table lists the pin numbers and their description for ST-3624.

Table 109: ST-3624: Pin Description

Pin Number	Description	Pin Number	Description
0	Input Channel 0	1	Input Channel 1
2	Input Channel 2	3	Input Channel 3
4	Input Channel Common (0V)	5	Input Channel Common (0V)
6	Chassis Ground/Shield	7	Chassis Ground/Shield

Specification

The following table describes the Input Specifications and the General Specifications for ST-3624.

Table 110: ST-3624: Input and General Specifications

Items	Specification
Input Specification	
Number of Inputs	4 Channels Single Ended, Non-isolated Between Channels
Indicators	4 Green/Red States, 1 Green/Red RSTi Bus State
Resolution in Ranges	12 Bits: 1.22mV/Bit
Input Voltage Range	0 ~ 5Vdc
Data Format	16 bits Integer (2's compliment)
Module Error	±0.1% Full Scale @25°C ±0.3% Full Scale @0°C, 60°C
Input Impedance	500KΩ
Conversion Time	4msec/All channel
Calibration	Not Required
Diagnostic	No
Common Type	4 Channels/2 COM (Single Common)
General Specification	
Power Supply	From System Power DC/DC
Power Dissipation	Maximum 170mA @ 5.0Vdc
Isolation	I/O to Logic: Photo coupler isolation Field power: Not Connected
Wiring	I/O Cable Maximum 2.0mm ²
Weight	70g
Module Size	12mm x 99mm x 70mm
Environment Condition	See "Environmental Specifications" in Appendix A.

ST-3644

Interface and Data

The following illustration shows the interface design for ST-3644.

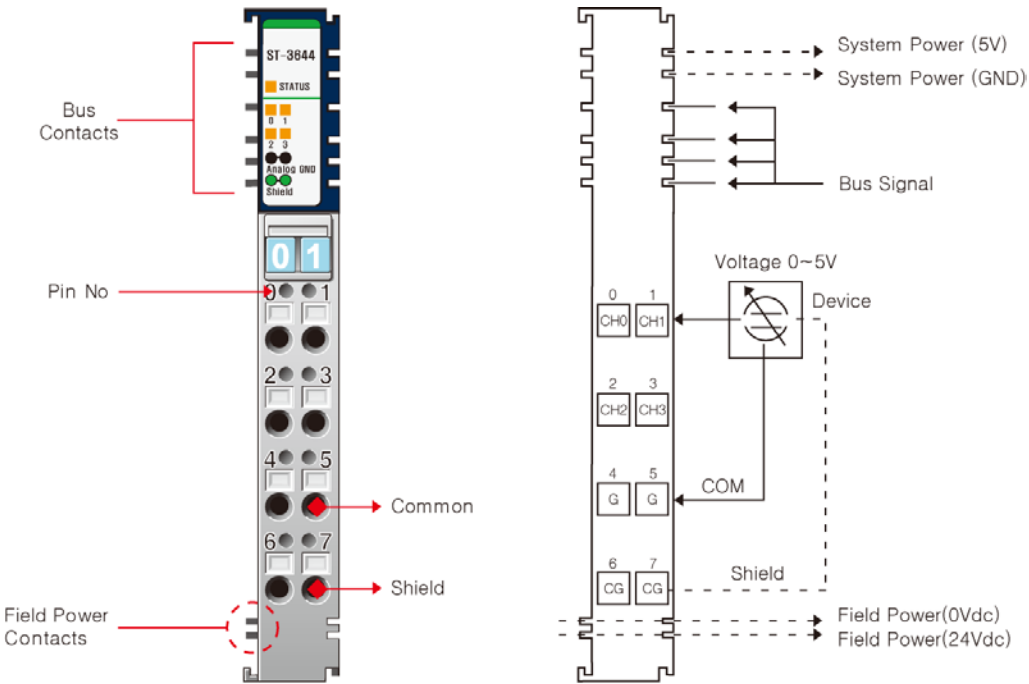

Figure 70: Analog Input Module: ST-3644

The following table lists the pin numbers and their description for ST-3644.

Table 111: ST-3644: Pin Description

Pin Number	Description	Pin Number	Description
0	Input Channel 0	1	Input Channel 1
2	Input Channel 2	3	Input Channel 3
4	Input Channel Common (0V)	5	Input Channel Common (0V)
6	Chassis Ground/Shield	7	Chassis Ground/Shield

Specification

The following table describes the Input Specifications and the General Specifications for ST-3644.

Table 112: ST-3644: Input and General Specifications

Items	Specification
Input Specification	
Number of Inputs	4 Channels Single Ended, Non-isolated Between Channels
Indicators	4 Green/Red States, 1 Green/Red RSTi Bus State
Resolution in Ranges	14 Bits: 0.3mV/Bit
Input Voltage Range	0 ~ 5Vdc
Data Format	16 bits Integer (2's compliment)
Module Error	±0.1% Full Scale @25°C ±0.3% Full Scale @0°C, 60°C
Input Impedance	500KΩ
Conversion Time	4msec/All channel
Calibration	Not Required
Diagnostic	No
Common Type	4 Channels/2 COM (Single Common)
General Specification	
Power Supply	From System Power DC/DC
Power Dissipation	Maximum 200mA @ 5.0Vdc
Isolation	I/O to Logic: Photo coupler isolation Field power: Not Connected
Wiring	I/O Cable Maximum 2.0mm ²
Weight	70g
Module Size	12mm x 99mm x 70mm
Environment Condition	See "Environmental Specifications" in Appendix A.

ST-3702

Interface and Data

The following illustration shows the interface design for ST-3702.

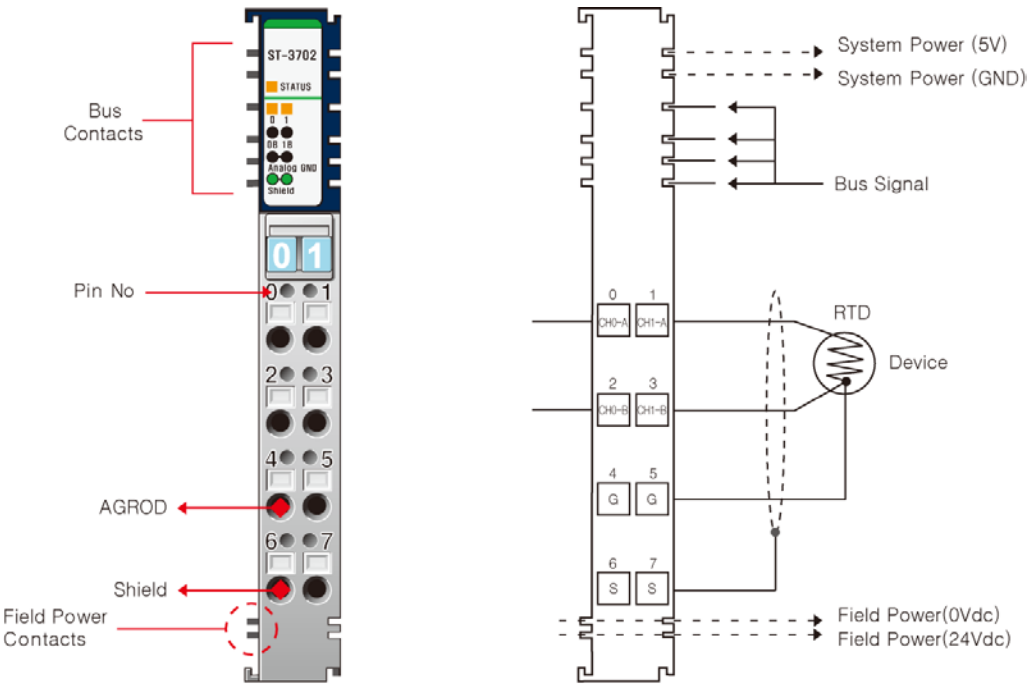

Figure 71: Analog Input Module: ST-3702

The following table lists the pin numbers and their description for ST-3702.

Table 113: ST-3702: Pin Description

Pin Number	Description	Pin Number	Description
0	Input Channel 0-A	1	Input Channel 1-A
2	Input Channel 0-B	3	Input Channel 1-B
4	Analog Ground	5	Analog Ground
6	Shield	7	Shield

Sensor Type Data

The following table lists the data related to Sensor Type.

Table 114: ST-3702: Sensor Type Data

Sensor Type	Degree	Counts	Resolution
Resistance 100mΩ	1~2000Ω	10~20000	100mΩ / 1count
Resistance 10mΩ	1~327Ω	10~3270	10mΩ / 1count
Resistance 20mΩ	1~620Ω	10~6200	20mΩ / 1count
PT50, 0.00385	200~850°C	-2000~8500	0.1°C or 0.1°F / count

PT100, 0.00385	-200~850°C	-2000~8500	0.1°C or 0.1°F / count
PT200, 0.00385	-200~850°C	-2000~8500	0.1°C or 0.1°F / count
PT500, 0.00385	-200~850°C	-2000~8500	0.1°C or 0.1°F / count
PT1000, 0.00385	-200~350°C	-2000~3500	0.1°C or 0.1°F / count
JPT100, 0.003916	-200~640°C	-2000~6400	0.1°C or 0.1°F / count
JPT200, 0.003916	-200~640°C	-2000~6400	0.1°C or 0.1°F / count
JPT500, 0.003916	-200~640°C	-2000~6400	0.1°C or 0.1°F / count
JPT1000, 0.003916	-200~350°C	-2000~3500	0.1°C or 0.1°F / count
NI100, 0.00618	-60~250°C	-600~2500	0.1°C or 0.1°F / count
NI120, 0.00672	-80~250°C	-800~2500	0.1°C or 0.1°F / count
NI200, 0.00618	-60~250°C	-600~2500	0.1°C or 0.1°F / count
NI500, 0.00618	-60~250°C	-600~2500	0.1°C or 0.1°F / count
NI1000, 0.00618	-60~180°C	-600~1800	0.1°C or 0.1°F / count
NI 1000 Balco	-40~120□	-400~1200`	0.1°C or 0.1°F / count
CU10, 0.00427	-200~260°C	-2000~2600	0.1°C or 0.1°F / count

Specification

The following table describes the Input Specifications and the General Specifications for ST-3702.

Table 115: ST-3702: Input and General Specifications

Items	Specification
Input Specification	
Number of Inputs	2 Channels Single Ended, Non-isolated Between Channels
Indicators	2 Green/Red States, 1 Green/Red RSTi Bus State
Sensor Types	PT50, PT100, PT200, PT500, PT1000, JPT100, JPT200, JPT500, JPT1000, NI100, NI200, NI500, NI1000, NI 1000 Balco, NI120, CU10, Resistance 100mΩ/Bit, Resistance 10mΩ/Bit, Resistance 20mΩ/Bit
Conversion Time	200msec/All Channel
Data Format	16 bits Integer (2's compliment)
Dissolution ability	0.1°C/10mΩ
Module Error	±0.1% Full Scale @25°C ±0.3% Full Scale @0°C, 60°C
Calibration	Not Required
Diagnostic	Channel Open (if it is not Connected, Data=0x8000)
Common Type	2 Channels/2 COM (Single Channel)
General Specification	
Power Supply	From System Power DC/DC
Power Dissipation	Maximum 70mA @ 5.0Vdc
Isolation	I/O to Logic: Photo coupler isolation Field power: Not Connected
Wiring	I/O Cable Maximum 2.0mm ²
Weight	70g
Module Size	12mm x 99mm x 70mm
Environment Condition	See "Environmental Specifications" in Appendix A.

ST-3704

Interface and Data

The following illustration shows the interface design for ST-3704.

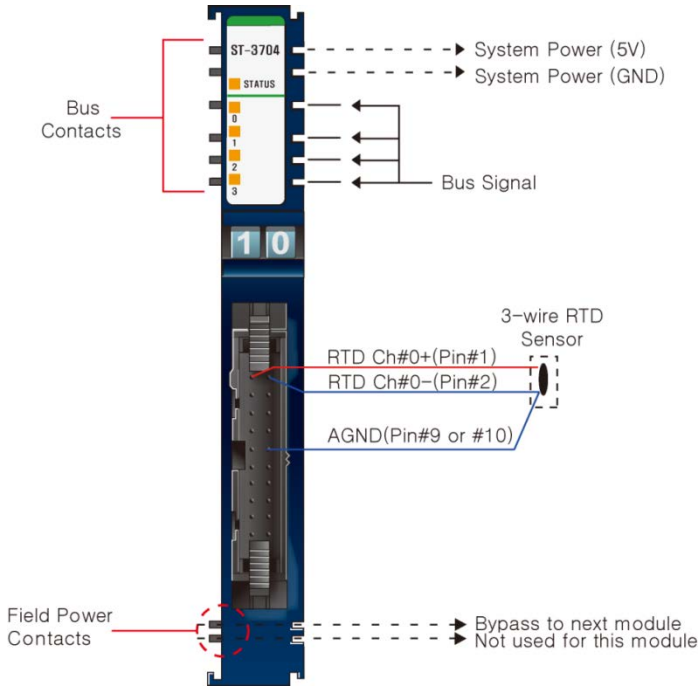

Figure 72: Analog Input Module: ST-3704

The following table lists the pin numbers and their description for ST-3704.

Table 116: ST-3704: Pin Description

Pin Number	Description	Pin Number	Description
1	RTD Ch#0+	2	RTD Ch#0-
3	RTD Ch#1+	4	RTD Ch#1-
5	RTD Ch#2+	6	RTD Ch#2-
7	RTD Ch#3+	8	RTD Ch#3-
9	AGND	10	AGND
11	----	12	----
13	----	14	----
15	----	16	----
17	----	18	----
19	AGND	20	AGND

Specification

The following table describes the Input Specifications and the General Specifications for ST-3704.

Table 117: ST-3704: Input and General Specifications

Items	Specification
Input Specification	
Number of Inputs	4 Channels
Indicators	1 Green/Red Status, 4 Green States
Sensor Types	RTD Input - PT 100, PT200, PT500, PT1000, PT50 - JPT100, JPT200, JPT500, JPT1000, JPT50 - NI100, NI200, NI500, NI000 - NI120, NI1000LG Resistance Input - 100mΩ/bit, 10mΩ/bit, 20mΩ/bit, 50mΩ/bit
Excitation Current	About 1mA
Conversion Method	3-Wire or 2-Wire
Conversion Time	30msec/1Channel when Normal Conversion
Data Format	16 bits signed Integer(2's compliment)
Resolution of Data	±0.1°C/F10mΩ
Module Accuracy	±0.3% Full Scale @25°C ±0.5% Full Scale @0°C, 60°C
Calibration	Not Required
Diagnostic	Sensor Open or Range Over, then Conversion Data=0x8000(-32768) Except Resistance Input Mode
Common Type	4 Common/Module
General Specification	
Power Dissipation	Maximum 100mA @5.0Vdc
Isolation	I/O to Control Logic: photo coupler Isolation
Field Power	Not used, Field Power by pass to next expansion module
Wiring	Connector Type, up to AWG22 Module Connector : HIF3BA-20PA-2.54DSA
Weight	70g
Module Size	12mm x 99mm x 70mm
Environment Condition	See "Environmental Specifications" in Appendix A.

ST-3708

Interface and Data

The following illustration shows the interface design for ST-3708.

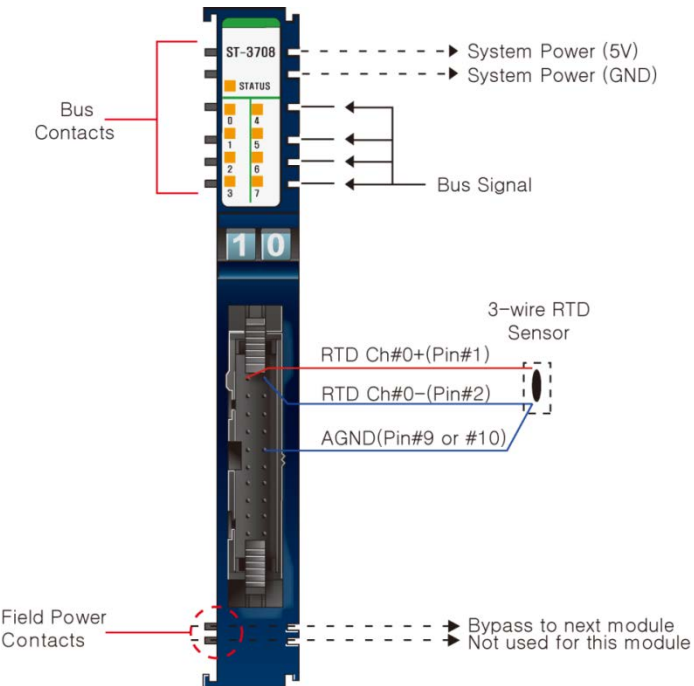

Figure 73: Analog Input Module: ST-3708

The following table lists the pin numbers and their description for ST-3708.

Table 118: ST-3708: Pin Description

Pin Number	Description	Pin Number	Description
1	RTD Ch#0+	2	RTD Ch#0-
3	RTD Ch#1+	4	RTD Ch#1-
5	RTD Ch#2+	6	RTD Ch#2-
7	RTD Ch#3+	8	RTD Ch#3-
9	AGND	10	AGND
11	RTD Ch#4+	12	RTD Ch#4-
13	RTD Ch#5+	14	RTD Ch#5-
15	RTD Ch#6+	16	RTD Ch#6-
17	RTD Ch#7+	18	RTD Ch#7-
19	AGND	20	AGND

Specification

The following table describes the Input Specifications and the General Specifications for ST-3708.

Table 119: ST-3708: Input and General Specifications

Items	Specification
Input Specification	
Number of Inputs	8 Channels
Indicators	1 Green/Red LED, Module Status, 8 Green LED, Input State
Sensor Types	RTD Input - PT 100, PT200, PT500, PT1000, PT50 - JPT100, JPT200, JPT500, JPT1000, JPT50 - NI100, NI200, NI500, NI000 - NI120, NI1000LG Resistance Input - 100mΩ/bit, 10mΩ/bit, 20mΩ/bit, 50mΩ/bit
Excitation Current	About 1mA
Conversion Method	3-Wire or 2-Wire
Conversion Time	30msec/1Channel when Normal Conversion
Data Format	16 bits signed Integer (2's compliment)
Resolution of Data	±0.1°C/F, 10mΩ
Module Accuracy	±0.3% Full Scale @25°C ±0.5% Full Scale @0°C, 60°C
Calibration	Not Required
Diagnostic	Sensor Open or Range Over, then Conversion Data=0x8000(-32768) Except Resistance Input Mode
Common Type	4 Common/Module
General Specification	
Power Dissipation	Maximum 100mA @5.0Vdc
Isolation	I/O to Control Logic : photo coupler Isolation
Field Power	Not used, Field Power by pass to next expansion module
Wiring	Connector Type, up to AWG22 Module Connector: HIF3BA-20PA-2.54DSA
Weight	70g
Module Size	12mm x 99mm x 70mm
Environment Condition	See "Environmental Specifications" in Appendix A.

ST-3802

Interface and Data

The following illustration shows the interface design for ST-3802.

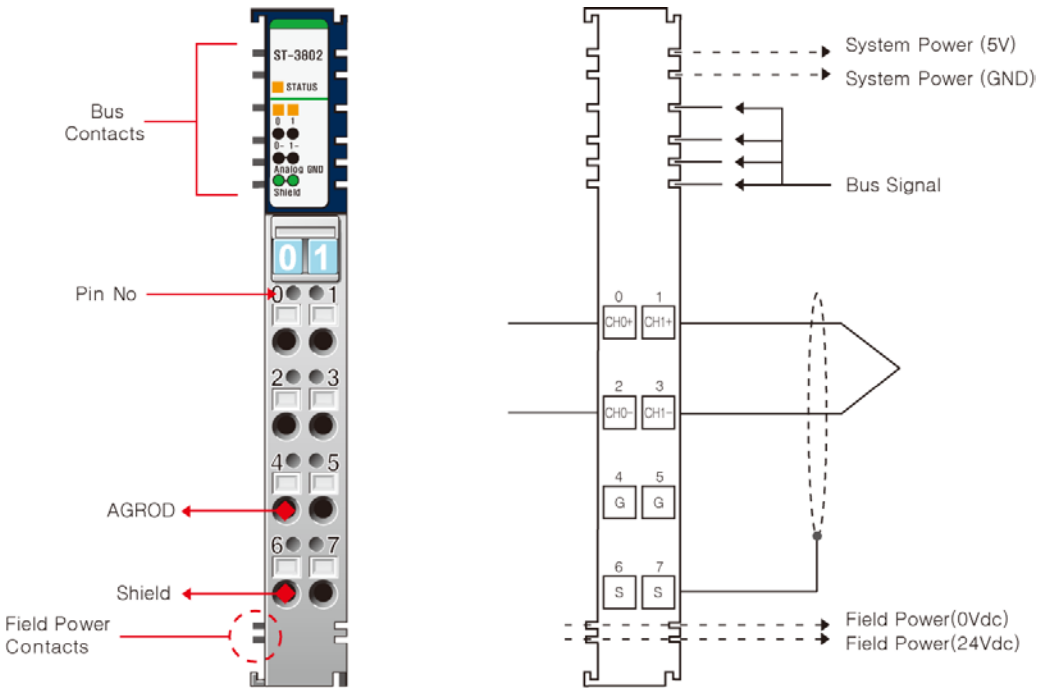

Figure 74: Analog Input Module: ST-3802

The following table lists the pin numbers and their description for ST-3802.

Table 120: ST-3802: Pin Description

Pin Number	Description	Pin Number	Description
0	Input Channel 0+	1	Input Channel 1+
2	Input Channel 0-	3	Input Channel 1-
4	Analog Ground	5	Analog Ground
6	Shield	7	Shield

Specification

The following table describes the Input Specifications and the General Specifications for ST-3802.

Table 121: ST-3802: Input and General Specifications

Items	Specification
Input Specification	
Number of Inputs	2 Channels Single Ended, Non-isolated Between Channels
Indicators	2 Green/Red States, 1 Green/Red RSTi Bus State
Sensor Types	Type K/J/T/B/R/S/E/N/L/U/C/D mV Input 10 μ V/Bit, 1 μ V/Bit, 2 μ V/Bit
Conversion Time	200msec/All Channel
Data Format	16 bits Integer (2's compliment)
Resolution of Data	$\pm 0.1^{\circ}\text{C}/10\text{m}\Omega$
Module Error	$\pm 0.1\%$ Full Scale @ 25 $^{\circ}\text{C}$ $\pm 0.3\%$ Full Scale @ 0 $^{\circ}\text{C}$, 60 $^{\circ}\text{C}$
Calibration	Not Required
Diagnostic	Channel Open (if it is not Connected, Data=0x8000)
Common Type	2 Channels/2 COM (Single Common)
General Specification	
Power Supply	From System Power DC/DC
Power Dissipation	Maximum 70mA @ 5.0Vdc
Isolation	I/O to Logic: Photo coupler isolation Field power: Not Connected
Connection	2 or 3-Wire
Wiring	I/O Cable Maximum 2.0mm
Weight	70g
Module Size	12mm x 99mm x 70mm
Environment Condition	See "Environmental Specifications" in Appendix A.

ST-3804

Interface and Data

The following illustration shows the interface design for ST-3804.

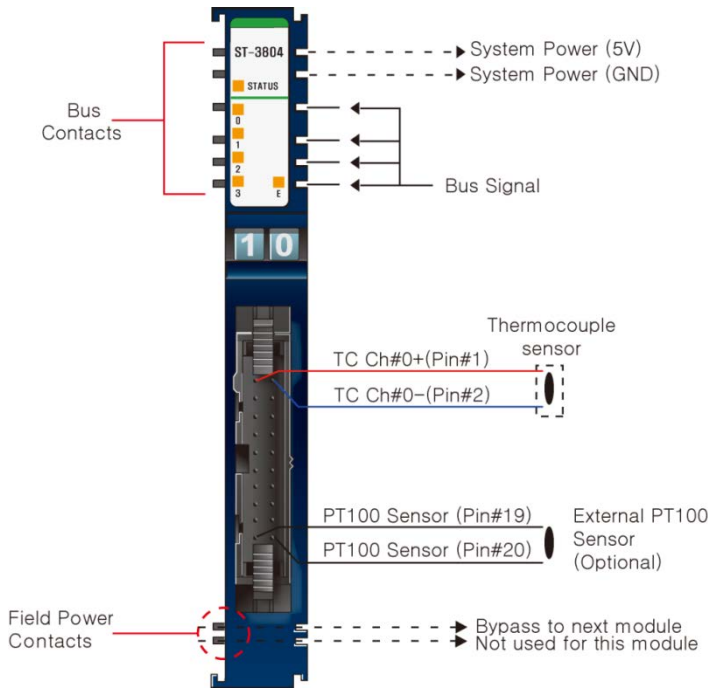

Figure 75: Analog Input Module: ST-3804

The following table lists the pin numbers and their description for ST-3804.

Table 122: ST-3804: Pin Description

Pin Number	Description	Pin Number	Description
1	TC Ch#0+	2	TC Ch#0-
3	TC Ch#1+	4	TC Ch#1-
5	TC Ch#2+	6	TC Ch#2-
7	TC Ch#3+	8	TC Ch#3-
9	AGND	10	AGND
11	----	12	----
13	----	14	----
15	----	16	----
17	----	18	----
19	AGND	20	AGND

Specification

The following table describes the Input Specifications and the General Specifications for ST-3804.

Table 123: ST-3804: Input and General Specifications

Items	Specification
Input Specification	
Number of Inputs	4 Channels
Indicators	1 Green/Red LED, Module Status 4 Green LED, Input State
Sensor Types	Thermocouple Input - Type K/J/T/B/R/S/E/N/L/U/C/D mV Input -10uV/bit, 1uV/bit, 2uV/bit
Cold Junction Temperature	-20~70°C
Conversion Time	30msec/1Channel when Normal Conversion
Data Format	16 bits Integer(2's compliment)
Resolution of Data	0.1°C/°C, 10mΩ
Module Accuracy	±0.3% Full Scale @25°C (K/J/mV) ±0.5% Full Scale @0°C, 60°C(K/J/mV) ±0.5% Full Scale @25°C (others) ±1.0% Full Scale @0°C, 60°C (others)
Calibration	Not Required
Diagnostic	Sensor Open or Range Over, then Conversion Data=0x8000(-32768)
Common Type	4 Common/Module
General Specification	
Power Dissipation	Maximum 120mA @ 5.0Vdc
Isolation	I/O to Control Logic : Photo Coupler Isolation
Field Power	Not used, Field Power by pass to next expansion module
Wiring	Connector Type, up to AWG22 Module Connector : HIF3BA-20PA-2.54DSA
Weight	70g
Module Size	12mm x 99mm x 70mm
Environment Condition	See "Environmental Specifications" in Appendix A.

ST-3808

Interface and Data

The following illustration shows the interface design for ST-3808.

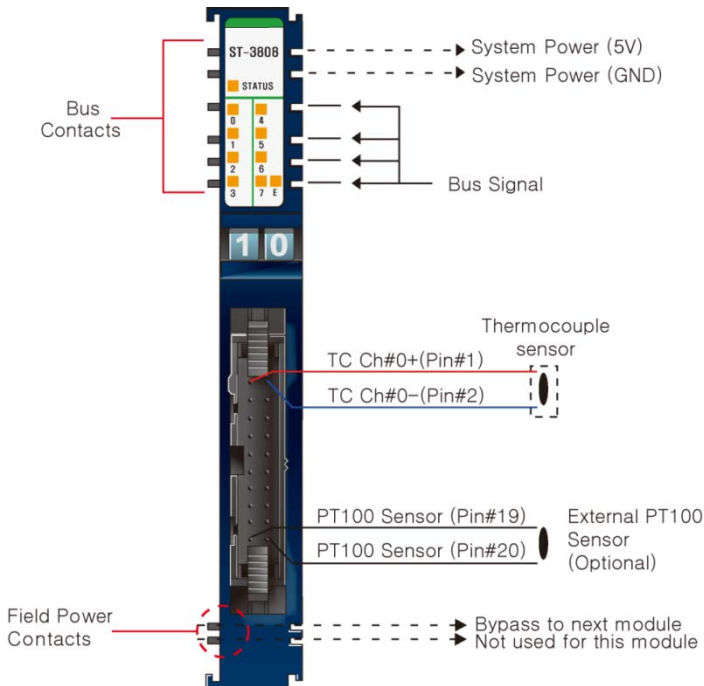

Figure 76: Analog Input Module: ST-3808

The following table lists the pin numbers and their description for ST-3808.

Table 124: ST-3808: Pin Description

Pin Number	Description	Pin Number	Description
1	TC Ch#0+	2	TC Ch#0-
3	TC Ch#1+	4	TC Ch#1-
5	TC Ch#2+	6	TC Ch#2-
7	TC Ch#3+	8	TC Ch#3-
9	AGND	10	AGND
11	TC Ch#4+	12	TC Ch#4-
13	TC Ch#5+	14	TC Ch#5-
15	TC Ch#6+	16	TC Ch#6-
17	TC Ch#7+	18	TC Ch#7-
19	AGND	20	AGND

Specification

The following table describes the Input Specifications and the General Specifications for ST-3808.

Table 125: ST-3808: Input and General Specifications

Items	Specification
Input Specification	
Number of Inputs	8 Channels
Indicators	1 Green/Red LED, Module Status 8 Green LED, Input Status
Sensor Types	Thermocouple Input - Type K/J/T/B/R/S/E/N/L/U/C/D mV Input - 10uV/bit, 1uV/bit, 2uV/bit
Cold Junction Temperature	-20~70°C
Conversion Time	30msec/1 Channel when Normal Conversion
Data Format	16 bits Integer (2's compliment)
Resolution of Data	±0.1°C/ F, 10mΩ
Module Accuracy	±0.3% Full Scale @25°C (K/J/mV) ±0.5% Full Scale @0°C, 60°C (K/J/mV) ±0.5% Full Scale @25°C (others) ±1.0% Full Scale @0°C, 60°C (others)
Calibration	Not Required
Diagnostic	Sensor Open or Range Over, then Conversion Data=0x8000 (-32768)
Common Type	4 Common/Module
General Specification	
Power Dissipation	Maximum 140mA @ 5.0Vdc
Isolation	I/O to Control Logic: photo coupler Isolation
Field Power	Not used, Field Power by pass to next expansion module
Wiring	Connector Type, up to AWG22 Module Connector: HIF3BA-20PA-2.54DSA
Weight	70g
Module Size	12mm x 99mm x 70mm
Environment Condition	See "Environmental Specifications" in Appendix A.

Dimension

ST-3xx2, ST-3xx4, and ST-3xx8

The following illustration shows the dimensions for ST-3xx2, ST-3xx4, and ST-3xx8 series.

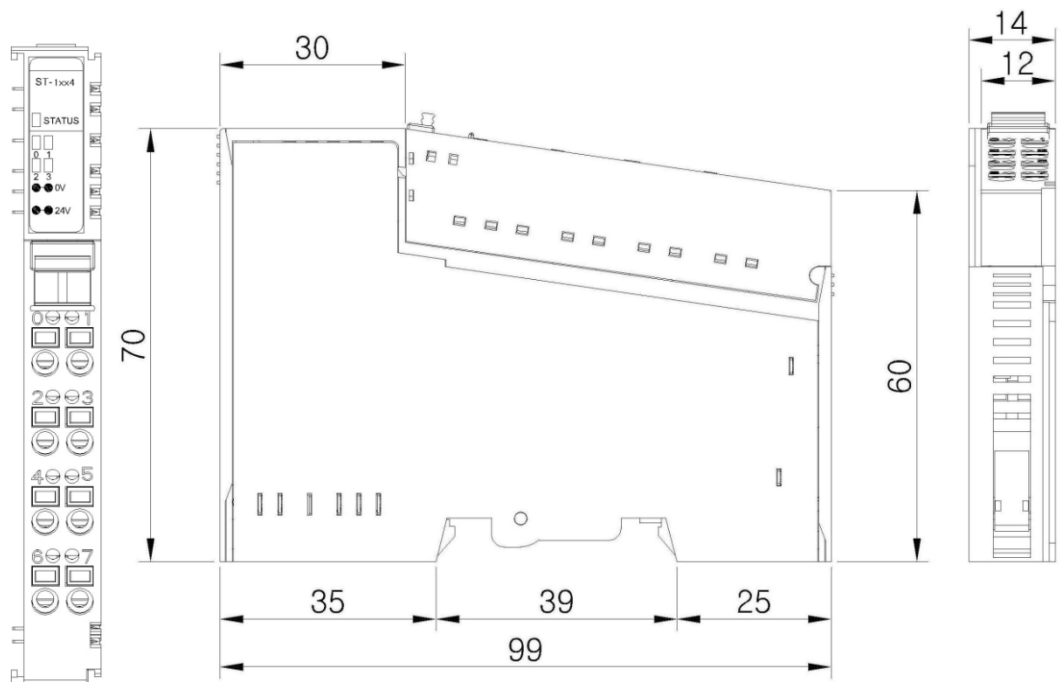

Figure 77: ST-3xx2, ST-3xx4, and ST-3xx8 Dimensions

ST-3704, ST-3708, ST-3804, and ST-3808

The following illustration shows the dimensions for ST-3704, ST-3708, ST-3804, and ST-3808 series.

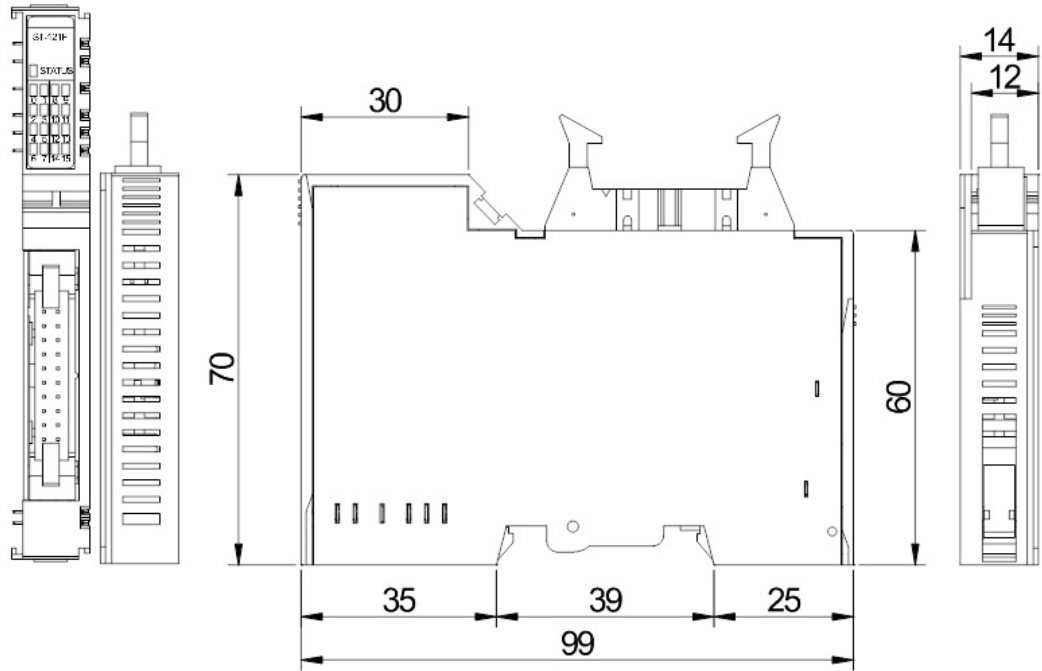

Figure 78: ST-3704, ST-3708, ST-3804, and ST-3808 Dimensions

Mapping Data into the Image Table

ST-3xx2

Input Module Data

Analog Input Ch 0
Analog Input Ch 1



Input Image Value

Bit No	Bit7	Bit6	Bit5	Bit4	Bit3	Bit2	Bit1	Bit0
Byte 0	Analog input Ch 0 Low byte							
Byte 1	Analog input Ch 0 High byte							
Byte 2	Analog input Ch 1 Low byte							
Byte 3	Analog input Ch 1 High byte							

ST-3xx4

Input Module Data

Analog Input Ch 0
Analog Input Ch 1
Analog Input Ch 2
Analog Input Ch 3



Input Image Value

Bit No	Bit7	Bit6	Bit5	Bit4	Bit3	Bit2	Bit1	Bit0
Byte 0	Analog Input Ch 0 Low byte							
Byte 1	Analog Input Ch 0 High byte							
Byte 2	Analog Input Ch 1 Low byte							
Byte 3	Analog Input Ch 1 High byte							
Byte 4	Analog Input Ch 2 Low byte							
Byte 5	Analog Input Ch 2 High byte							
Byte 6	Analog Input Ch 3 Low byte							
Byte 7	Analog Input Ch 3 High byte							

ST-3xx8

Input Module Data - 16 byte Input Data

Analog Input Ch 0
Analog Input Ch 1
Analog Input Ch 2
Analog Input Ch 3
Analog Input Ch 4
Analog Input Ch 5
Analog Input Ch 6
Analog Input Ch 7

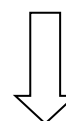

Input Image Value

Bit No	Bit7	Bit6	Bit5	Bit4	Bit3	Bit2	Bit1	Bit0
Byte 0	Analog Input Ch 0 Low byte							
Byte 1	Analog Input Ch 0 High byte							
Byte 2	Analog Input Ch 1 Low byte							
Byte 3	Analog Input Ch 1 High byte							
Byte 4	Analog Input Ch 2 Low byte							
Byte 5	Analog Input Ch 2 High byte							
Byte 6	Analog Input Ch 3 Low byte							
Byte 7	Analog Input Ch 3 High byte							
Byte 8	Analog Input Ch4 Low byte							
Byte 9	Analog Input Ch4 High byte							
Byte 10	Analog Input Ch5 Low byte							
Byte 11	Analog Input Ch5 High byte							
Byte 12	Analog Input Ch6 Low byte							
Byte 13	Analog Input Ch6 High byte							
Byte 14	Analog Input Ch7 Low byte							
Byte 15	Analog Input Ch7 High byte							

ST-3704

IO Input Image Data – 8 byte

Bit No	Bit 7	Bit 6	Bit 5	Bit 4	Bit 3	Bit 2	Bit 1	Bit 0
Byte 0	Ch#0 Conversion Data Low byte							
Byte 1	Ch#0 Conversion Data High byte							
Byte 2	Ch#1 Conversion Data Low byte							
Byte 3	Ch#1 Conversion Data High byte							
Byte 4	Ch#2 Conversion Data Low byte							
Byte 5	Ch#2 Conversion Data High byte							
Byte 6	Ch#3 Conversion Data Low byte							
Byte 7	Ch#3 Conversion Data High byte							

Configuration Parameter Data – 2 byte

Byte	Bit 7	Bit 6	Bit 5	Bit 4	Bit 3	Bit 2	Bit 1	Bit 0
0	Sensor Type							
	Sensor Type =00h:PT100, 0.00385, -200~850°C, 0.1°C or 0.1°F/bit =01h:PT200, 0.00385, -200~850°C, 0.1°C or 0.1°F/bit =02h:PT500, 0.00385, -200~850°C, 0.1°C or 0.1°F/bit =03h:PT1000, 0.00385, -200~350°C, 0.1°C or 0.1°F/bit =04h:PT50, 0.00385, -200~850°C, 0.1°C or 0.1°F/bit =10h:JPT100, 0.003916, -200~640°C, 0.1°C or 0.1°F/bit =11h:JPT200, 0.003916, -200~640°C, 0.1°C or 0.1°F/bit =12h:JPT500, 0.003916, -200~640°C, 0.1°C or 0.1°F/bit =13h:JPT1000, 0.003916, -200~350°C, 0.1°C or 0.1°F/bit =14h:JPT50, 0.003916, -200~350°C, 0.1°C or 0.1°F/bit =20h:NI100, 0.00618, -60~250°C, 0.1°C or 0.1°F/bit =21h:NI200, 0.00618, -60~250°C, 0.1°C or 0.1°F/bit =22h:NI500, 0.00618, -60~250°C, 0.1°C or 0.1°F/bit =23h:NI1000, 0.00618, -60~180°C, 0.1°C or 0.1°F/bit =30h:NI120, 0.00672, -80~250°C, 0.1°C or 0.1°F/bit =53h:NI1000LG, -50~120°C, 0.1°C or 0.1°F/bit =80h:Resistance Input, 0~2000ohm, 100mOhm/bit =81h: Resistance Input, 0~327ohm, 10mOhm/bit =82h: Resistance Input, 0~620ohm, 20mOhm/bit =83h: Resistance Input, 1~1200ohm, 50mOhm/bit =others: Reserved							
1	---	---	---	N/E	---	0.1/1	---	C/F
	Bit 0 (C/F): 0:Celsius(°C), 1:Fahrenheit(°F) Bit 2 (0.1/1) : Data Resolution, 0:0.1°C, °F/bit, 1:1°C, °F/bit Bit 4 (N/E): 0:Normal Conversion, 1:Enhanced Conversion - Enhanced Conversion makes conversion data stable, but more conversion time Other bits : Reserved							

IO Input Image Data – 8 byte

Bit No	Bit 7	Bit 6	Bit 5	Bit 4	Bit 3	Bit 2	Bit 1	Bit 0
Byte 0	Ch#0 Conversion Data Low byte							
Byte 1	Ch#0 Conversion Data High byte							
Byte 2	Ch#1 Conversion Data Low byte							
Byte 3	Ch#1 Conversion Data High byte							
Byte 4	Ch#2 Conversion Data Low byte							
Byte 5	Ch#2 Conversion Data High byte							
Byte 6	Ch#3 Conversion Data Low byte							
Byte 7	Ch#3 Conversion Data High byte							
Byte 8	Ch#4 Conversion Data Low Byte							
Byte 9	Ch#4 Conversion Data High Byte							
Byte 10	Ch#5 Conversion Data Low Byte							
Byte 11	Ch#5 Conversion Data High Byte							
Byte 12	Ch#6 Conversion Data Low Byte							
Byte 13	Ch#6 Conversion Data High Byte							
Byte 14	Ch#7 Conversion Data Low Byte							
Byte 15	Ch#7 Conversion Data High Byte							

- If the input of channel is open or over-ranged, its conversion data will be 0x8000 (-32678)
- In case of 100mOhm/bit, 10mOhm/bit, 20mOhm/bit and 50mOhm/bit, only over range will be 0x8000(-32678)

Configuration Parameter Data – 2 byte

Byte	Bit 7	Bit 6	Bit 5	Bit 4	Bit 3	Bit 2	Bit 1	Bit 0
0	Sensor Type							
	Sensor Type =00h:PT100, 0.00385, -200~850°C, 0.1°C or 0.1°F/bit =01h:PT200, 0.00385, -200~850°C, 0.1°C or 0.1°F/bit =02h:PT500, 0.00385, -200~850°C, 0.1°C or 0.1°F/bit =03h:PT1000, 0.00385, -200~350°C, 0.1°C or 0.1°F/bit =04h:PT50, 0.00385, -200~850°C, 0.1°C or 0.1°F/bit =10h:JPT100, 0.003916, -200~640°C, 0.1°C or 0.1°F/bit =11h:JPT200, 0.003916, -200~640°C, 0.1°C or 0.1°F/bit =12h:JPT500, 0.003916, -200~640°C, 0.1°C or 0.1°F/bit =13h:JPT1000, 0.003916, -200~350°C, 0.1°C or 0.1°F/bit =14h:JPT50, 0.003916, -200~350°C, 0.1°C or 0.1°F/bit =20h:NI100, 0.00618, -60~250°C, 0.1°C or 0.1°F/bit =21h:NI200, 0.00618, -60~250°C, 0.1°C or 0.1°F/bit =22h:NI500, 0.00618, -60~250°C, 0.1°C or 0.1°F/bit =23h:NI1000, 0.00618, -60~180°C, 0.1°C or 0.1°F/bit =30h:NI120, 0.00672, -80~250°C, 0.1°C or 0.1°F/bit =53h:NI1000LG, -50~120°C, 0.1°C or 0.1°F/bit =80h:Resistance Input, 0~2000ohm, 100mOhm/bit							

	=81h: Resistance Input, 0~327ohm, 10mOhm/bit =82h: Resistance Input, 0~620ohm, 20mOhm/bit =83h: Resistance Input, 0~1200ohm, 50mOhm/bit =others: Reserved							
1	---	---	---	N/E	---	0.1/1	---	C/F
	Bit 0 (C/F): 0:Celsius(°C), 1:Fahrenheit (°F) Bit 2 (0.1/1) : Data Resolution, 0:0.1°C,°F/bit, 1:1°C,°F/bit Bit 4 (N/E): 0:Normal Conversion, 1:Enhanced Conversion - Enhanced Conversion makes conversion data stable, but more conversion time Other bits: Reserved							

ST-3804

IO Input Image Data – 8 byte

Bit No	Bit 7	Bit 6	Bit 5	Bit 4	Bit 3	Bit 2	Bit 1	Bit 0
Byte 0	Ch#0 Conversion Data Low byte							
Byte 1	Ch#0 Conversion Data High byte							
Byte 2	Ch#1 Conversion Data Low byte							
Byte 3	Ch#1 Conversion Data High byte							
Byte 4	Ch#2 Conversion Data Low byte							
Byte 5	Ch#2 Conversion Data High byte							
Byte 6	Ch#3 Conversion Data Low byte							
Byte 7	Ch#3 Conversion Data High byte							

- If the input of channel is open or over-ranged, its conversion data will be 0x8000 (-32678)

Configuration Parameter Data – 8 byte

Byte	Bit 7	Bit 6	Bit 5	Bit 4	Bit 3	Bit 2	Bit 1	Bit 0
0	Sensor Type							
	Sensor Type =00h: Type K, 0.1°C or 0.1°F/count =01h: Type J, 0.1°C or 0.1°F/count =02h: Type T, 0.1°C or 0.1°F/count =03h: Type B, 0.1°C or 0.1°F/count =04h: Type R, 0.1°C or 0.1°F/count =05h: Type S, 0.1°C or 0.1°F/count =06h: Type E, 0.1°C or 0.1°F/count =07h: Type N, 0.1°C or 0.1°F/count =08h: Type L, 0.1°C or 0.1°F/count =09h: Type U, 0.1°C or 0.1°F/count =0Ah: Type C, 0.1°C or 0.1°F/count =0Bh: Type D, 0.1°C or 0.1°F/count =80h: 10uV Input, -80.0~81.0mV, 10uV/1count =81h: 1uV Input, -32.7~32.7mV, 1uV/1count =82h: 2uV Input, -65.5~65.5mV, 2uV/1count =others: Reserved							
1	---	---	---	N/E	---	0.1/1	DCJ	C/F
	Bit 0 (C/F): 0:Celsius(°C), 1:Fahrenheit(°F) Bit 1 (DCJ) : 0:Cold Junction Compensation, 1:Cold Junction Compensation Disable(0°C) Bit 2 (0.1/1) : Data Resolution, 0:0.1°C,°F/bit, 1:1°C,°F/bit Bit 4 (N/E): 0:Normal Filter Conversion, 1:Enhanced Filter Conversion - Enhanced Conversion makes conversion data stable, but more conversion time Other bits : Reserved							
2	Cold Junction Temperature Offset Data Low Byte							
3	Cold Junction Temperature Offset Data High Byte							
4	Reserved							

5	Reserved
6	Reserved
7	Reserved

- Unit of Cold Junction Temperature is 0.1°C/°F. Value 254 means 25.4°C or 25.4°F
- DCJ=0: Compensation Cold Junction Temperature=Cold Junction Temperature – Cold Junction Temperature Offset
- DCJ=1: Compensation Cold Junction Temperature=Cold Junction Temperature Offset

Thermocouple Input Range

Type	Maximum Input Range	Recommended Input Range
Type K	-270 ~ 1372 °C	-200 ~ 1200 °C
Type J	-210 ~ 1200 °C	-100 ~ 1100 °C
Type T	-270 ~ 400 °C	-200 ~ 350 °C
Type B	30 ~ 1820 °C	300 ~ 1700 °C
Type R	-50 ~ 1768 °C	0 ~ 1600 °C
Type S	-50 ~ 1768 °C	0 ~ 1600 °C
Type E	-270 ~ 1000 °C	-200 ~ 800 °C
Type N	-270 ~ 1300 °C	-200 ~ 1250 °C
Type L	-200 ~ 900 °C	-100 ~ 850 °C
Type U	-200 ~ 600 °C	-100 ~ 550 °C
Type C	0 ~ 2310°C	100 ~ 2100 °C
Type D	0 ~ 2490°C	100 ~ 2200 °C

- °F = 1.8°C+32

IO Input Image Data – 16 byte

Bit No	Bit 7	Bit 6	Bit 5	Bit 4	Bit 3	Bit 2	Bit 1	Bit 0
Byte 0	Ch#0 Conversion Data Low byte							
Byte 1	Ch#0 Conversion Data High byte							
Byte 2	Ch#1 Conversion Data Low byte							
Byte 3	Ch#1 Conversion Data High byte							
Byte 4	Ch#2 Conversion Data Low byte							
Byte 5	Ch#2 Conversion Data High byte							
Byte 6	Ch#3 Conversion Data Low byte							
Byte 7	Ch#3 Conversion Data High byte							
Byte 8	Ch#4 Conversion Data Low Byte							
Byte 9	Ch#4 Conversion Data High Byte							
Byte 10	Ch#5 Conversion Data Low Byte							
Byte 11	Ch#5 Conversion Data High Byte							
Byte 12	Ch#6 Conversion Data Low Byte							
Byte 13	Ch#6 Conversion Data High Byte							
Byte 14	Ch#7 Conversion Data Low Byte							
Byte 15	Ch#7 Conversion Data High Byte							

- If the input of channel is open or over-ranged, its conversion data will be 0x8000 (-32678)

Configuration Parameter Data – 2 byte

Byte	Bit 7	Bit 6	Bit 5	Bit 4	Bit 3	Bit 2	Bit 1	Bit 0
0	Sensor Type							
	Sensor Type =00h: Type K, 0.1°C or 0.1°F/count =01h: Type J, 0.1°C or 0.1°F/count =02h: Type T, 0.1°C or 0.1°F/count =03h: Type B, 0.1°C or 0.1°F/count =04h: Type R, 0.1°C or 0.1°F/count =05h: Type S, 0.1°C or 0.1°F/count =06h: Type E, 0.1°C or 0.1°F/count =07h: Type N, 0.1°C or 0.1°F/count =08h: Type L, 0.1°C or 0.1°F/count =09h: Type U, 0.1°C or 0.1°F/count =0Ah: Type C, 0.1°C or 0.1°F/count =0Bh: Type D, 0.1°C or 0.1°F/count =80h: 10uV Input, -80.0~81.0mV, 10uV/1count =81h: 1uV Input, -32.7~32.7mV, 1uV/1count =82h: 2uV Input, -65.5~65.5mV, 2uV/1count =others: Reserved							
1	---	---	---	N/E	---	0.1/1	DCJ	C/F
	Bit 0 (C/F): 0:Celsius(°C), 1:Fahrenheit (°F) Bit 1 (DCJ): 0:Cold Junction Compensation, 1:Cold Junction Compensation							

	Disable (0°C) Bit 2 (0.1/1) : Data Resolution, 0:0.1°C,°F/bit, 1:1°C,°F/bit Bit 4 (N/E): 0:Normal Filter Conversion, 1:Enhanced Filter Conversion - Enhanced Conversion makes conversion data stable, but more conversion time Other bits : Reserved
2	Cold Junction Temperature Offset Data Low Byte
3	Cold Junction Temperature Offset Data High Byte
4	Reserved
5	Reserved
6	Reserved
7	Reserved

- Unit of Cold Junction Temperature is 0.1 °C/°F. Value 254 means 25.4°C or 25.4°F
- DCJ=0: Compensation Cold Junction Temperature = Cold Junction Temperature – Cold Junction Temperature Offset
- DCJ=1: Compensation Cold Junction Temperature =Cold Junction Temperature Offset

Thermocouple Input Range

Type	Maximum Input Range	Recommended Input Range
Type K	-270 ~ 1372 °C	-200 ~ 1200 °C
Type J	-210 ~ 1200 °C	-100 ~ 1100 °C
Type T	-270 ~ 400 °C	-200 ~ 350 °C
Type B	30 ~ 1820 °C	300 ~ 1700 °C
Type R	-50 ~ 1768 °C	0 ~ 1600 °C
Type S	-50 ~ 1768 °C	0 ~ 1600 °C
Type E	-270 ~ 1000 °C	-200 ~ 800 °C
Type N	-270 ~ 1300 °C	-200 ~ 1250 °C
Type L	-200 ~ 900 °C	-100 ~ 850 °C
Type U	-200 ~ 600 °C	-100 ~ 550 °C
Type C	0 ~ 2310°C	100 ~ 2100 °C
Type D	0 ~ 2490°C	100 ~ 2200 °C

- °F = 1.8°C+32

Current and Voltage Mode

ST-3114 and ST-3118

The following table lists the Current range for ST-3114 and ST-3118.

Table 126: ST-3114 and ST-3118: Input Current Range

Current	0.0mA	5.0mA	10.0mA	20.0mA
Data (Hex)	H 0000	H 03FF	H 07FF	H 0FFF

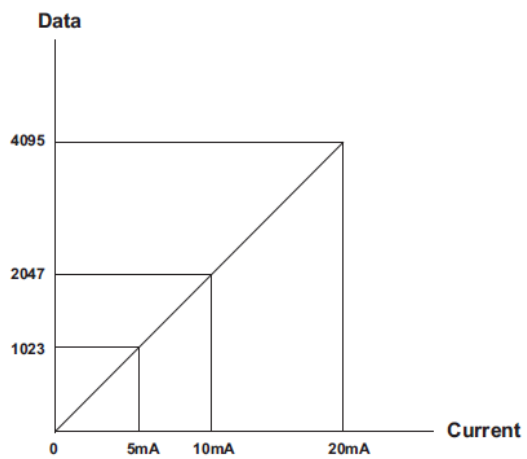

ST-3134

The following table lists the Current range for ST-3134.

Table 127: ST-3134: Input Current Range

Current	0.0mA	5.0mA	10.0mA	20.0mA
Data (Hex)	H 0000	H 03FF	H 1FFF	H 3FFF

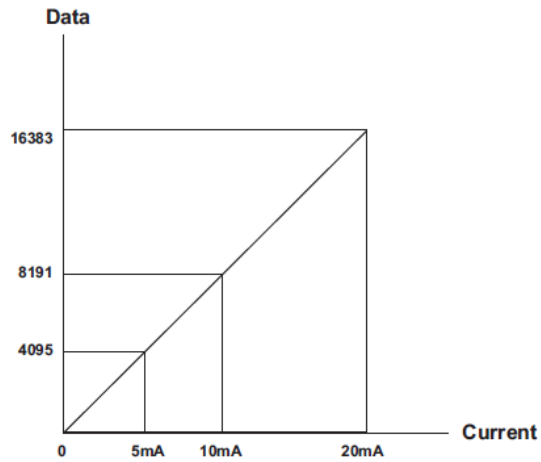

ST-3214

The following table lists the Current range for ST-3214.

Table 128: ST-3214: Input Current Range

Current	3.0mA	4.0mA	5.0mA	10.0mA	20.0mA
Data (Hex)	H 8000	H 0000	H 00FF	H 05FF	H 0FFF

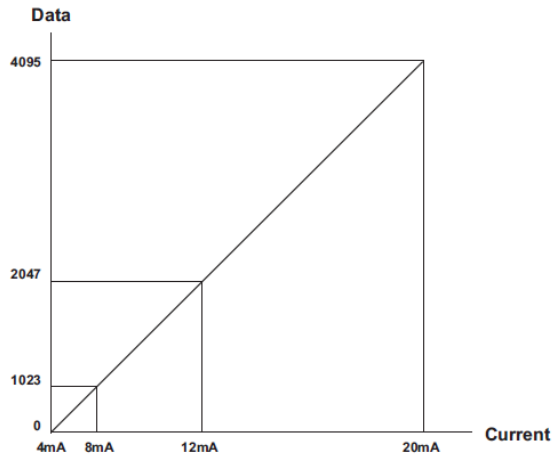

ST-3218

The following table lists the Current range for ST-3218.

Table 129: ST-3218: Input Current Range

Current	3.0mA	4.0mA	12.0mA	20.0mA
Data (Hex)	H 8000	H 0000	H 07FF	H 0FFF

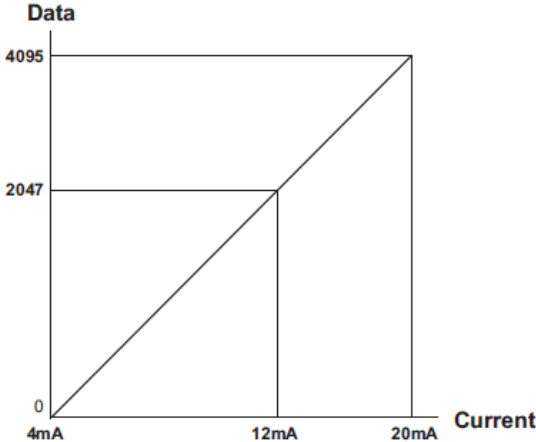

ST-3234

The following table lists the Current range for ST-3234.

Table 130: ST-3234: Input Current Range

Current	3.0mA	4.0mA	5.0mA	10.0mA	20.0mA
Data (Hex)	H 8000	H 0000	H 03FF	H 17FF	H 3FFF

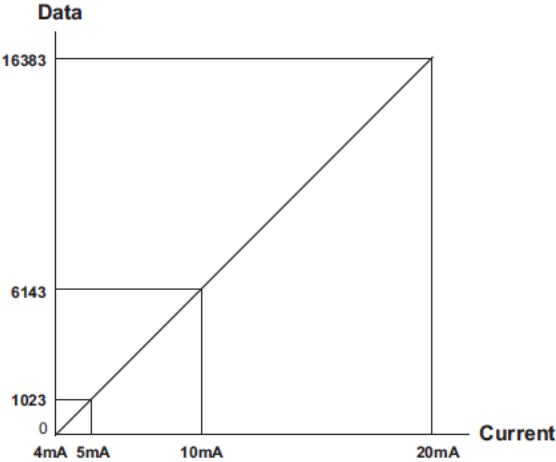

ST-3424, ST-3428

The following table lists the Voltage range for ST-3424 and ST-3428.

Table 131: ST-3424 and ST-3428: Input Voltage Range

Voltage	0V	2.5V	5V	10V
Data (Hex)	H 0000	H 03FF	H 07FF	H 0FFF

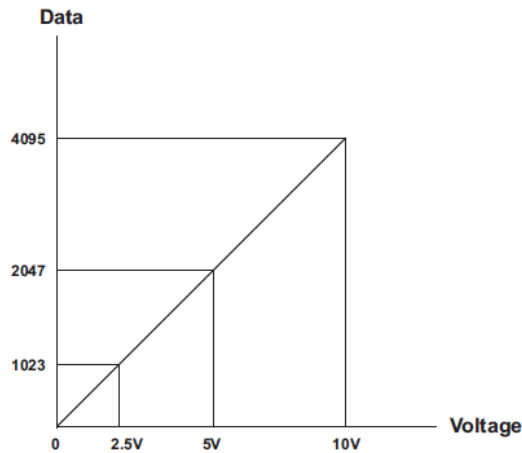

ST-3444

The following table lists the Voltage range for ST-3444.

Table 132: ST-3444: Input Voltage Range

Voltage	0V	2V	5V	10V
Data (Hex)	H 0000	H 0CCC	H 1FFF	H 3FFF

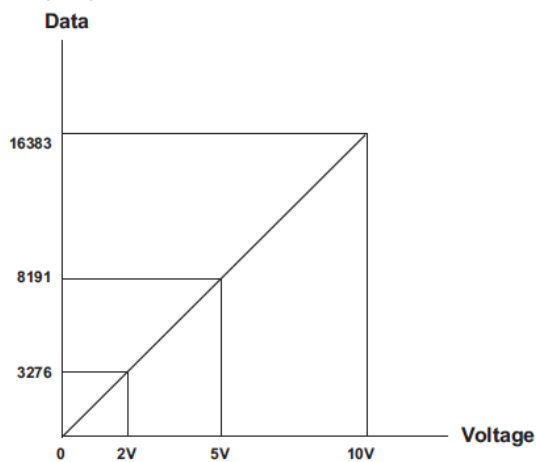

ST-3524

The following table lists the Voltage range for ST-3524.

Table 133: ST-3524: Input Voltage Range

Voltage	-10V	-5V	0V	5V	10V
Data (Hex)	H F800	H FC00	H 0000	H 03FF	H 07FF

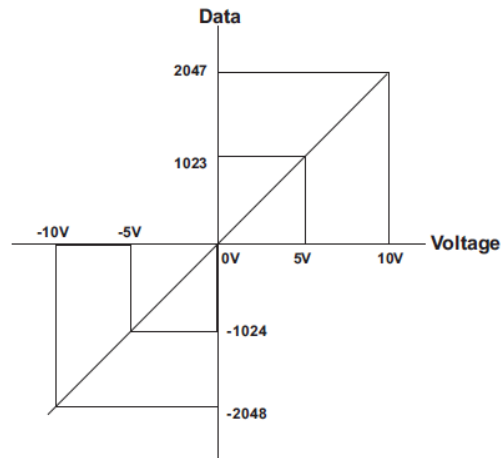

ST-3544

The following table lists the Voltage range for ST-3544.

Table 134: ST-3544: Input Voltage Range

Voltage	-10V	-5V	0V	5V	10V
Data (Hex)	H E000	H F000	H 0000	H 0FFF	H 1FFF

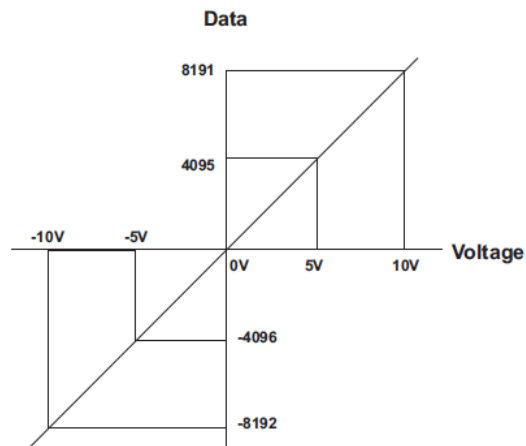

ST-3624

The following table lists the Current range for ST-3624.

Table 135: ST-3624: Input Current Range

Current	0V	2V	4V	5V
Data (Hex)	H 0000	H 0666	H 0CCC	H 0FFF

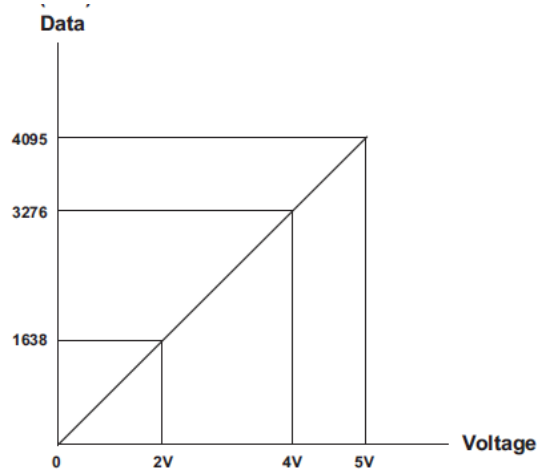

ST-3644

The following table lists the Voltage range for ST-3644.

Table 136: ST-3644: Input Voltage Range

Voltage	0V	2V	4V	5V
Data (Hex)	H 0000	H 1999	H 3332	H 3FFF

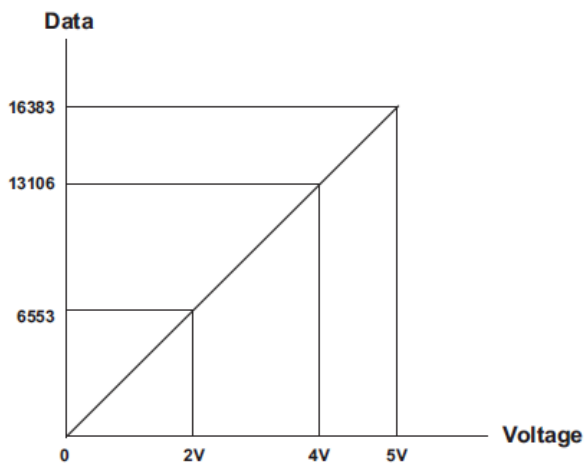

ST-3702

This section details the Input Resistance range for ST-3702.

Resistance 100Ω

Table 137: ST-3702: Input Resistance Range

Resistance	0Ω	500Ω	1000Ω	1500Ω	2000Ω
Data (Hex)	H 0000	H 1388	H 2710	H 3A98	H4E20

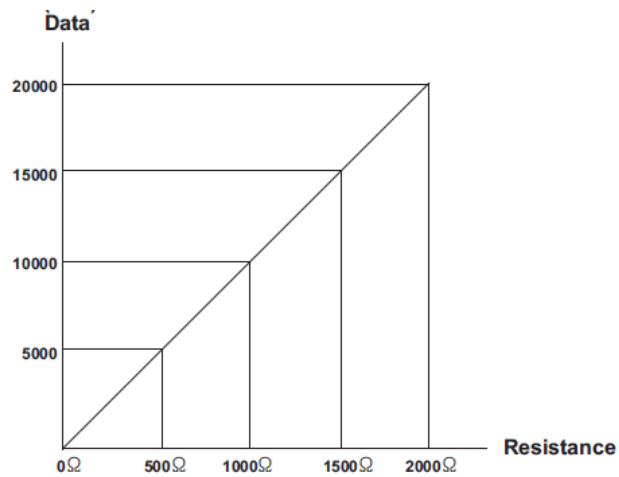

Sensor PT100

Table 138: ST-3702: Sensor PT100

°C	-200°C	-100°C	0°C	200°C	400°C	600°C	850°C
Data (Hex)	HF830	HFC18	H0000	H07D0	H0FA0	H1770	H2134

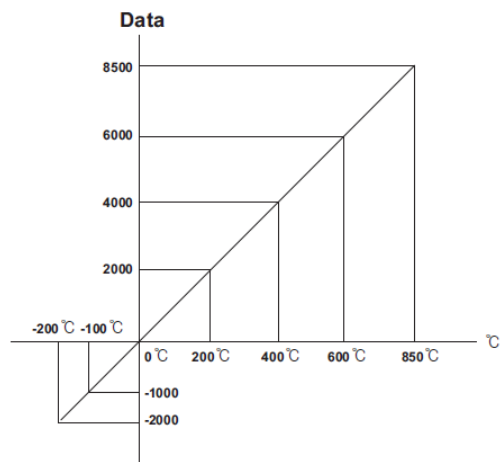

Sensor JPT 100

Table 139: ST-3702: Sensor JPT100

°C	-200 °C	-100 °C	0 °C	200 °C	400 °C	640 °C
Data (Hex)	HF830	HFC18	H0000	H07D0	H0FA0	H1900

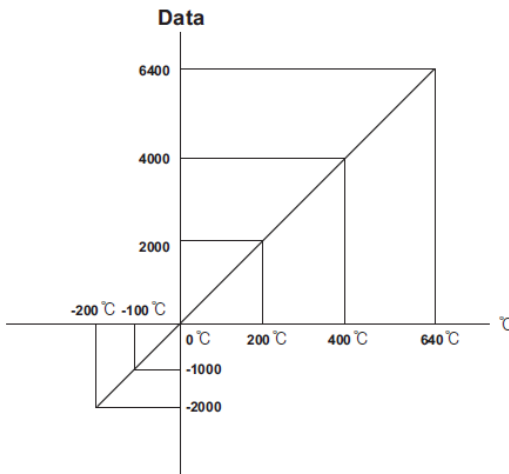

ST-3704, ST-3708, ST-3802, ST-3804, and ST-3808 – Type B

The following table lists the Output Current range for ST-3704, ST-3708, ST-3802, ST-3804, and ST-3808.

Table 140: Output Current Range

°C	0 °C	300 °C	900 °C	1800 °C
Data (Hex)	H 0000	H 0BB8	H 2328	H 4650

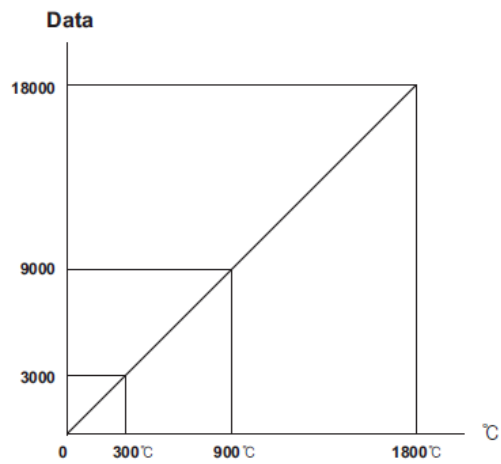

Diagnostics

Normal Module

The LEDs indicate the status of the module. The table below shows the corresponding functions of LEDs during normal operation. You can use this table as a reference for troubleshooting errors.

Table 141: LED functions of Normal Modules

Color	Status	Function
IO Modules Status LED		
Off	Not Power No Initialized	Device has no expansion Module or may not be powered The Parameter is not initialized yet.
Solid Green	RSTi Bus Connection	RSTi Bus Normal Operation
Flashing Green	RSTi Bus Ready	RSTi Bus Ready
Flashing Red	RSTi Bus Fault	RSTi Bus Time Out, RSTi Bus Failed Communication
Solid Red	Device Fault	Device fault
Channel Status LED		
Off	No Signal	Normal Operation
Solid Green	On Signal	Normal Operation

Note: For more help on troubleshooting errors related to Network Adaptor and its protocols, please refer to Network Adaptor User Manual.

ST-3704, ST-3708, ST-3804, ST-3808

The table below shows the corresponding functions of LEDs of other modules.

Table 142: LED functions of Other Modules

Color	Status	Function
IO Module Status LED		
Off	Not Power No Initialized	Device has no expansion Module or may not be powered The Parameter is not initialized yet.
Solid Green	Module Connection	RSTi Bus Normal Operation
Flashing Green	Module Ready	RSTi Bus Ready
Flashing Red	Module Fault	RSTi Bus Time Out, RSTi Bus Failed Communication
Solid Red	Module Fault	Device fault
Channel Status LED		
Off	Normal Operation	Input Sensor Open or Input Range Over
Solid Green	Normal Operation	Sensor Connected and Input Range Valid
Solid Red	Channel Fault	Channel Open

Analog Output Module has Current type and Voltage type based on 2/4 Channels
Voltage/Current.

ST-4112

Interface and Data

The following illustration shows the interface design for ST-4112.

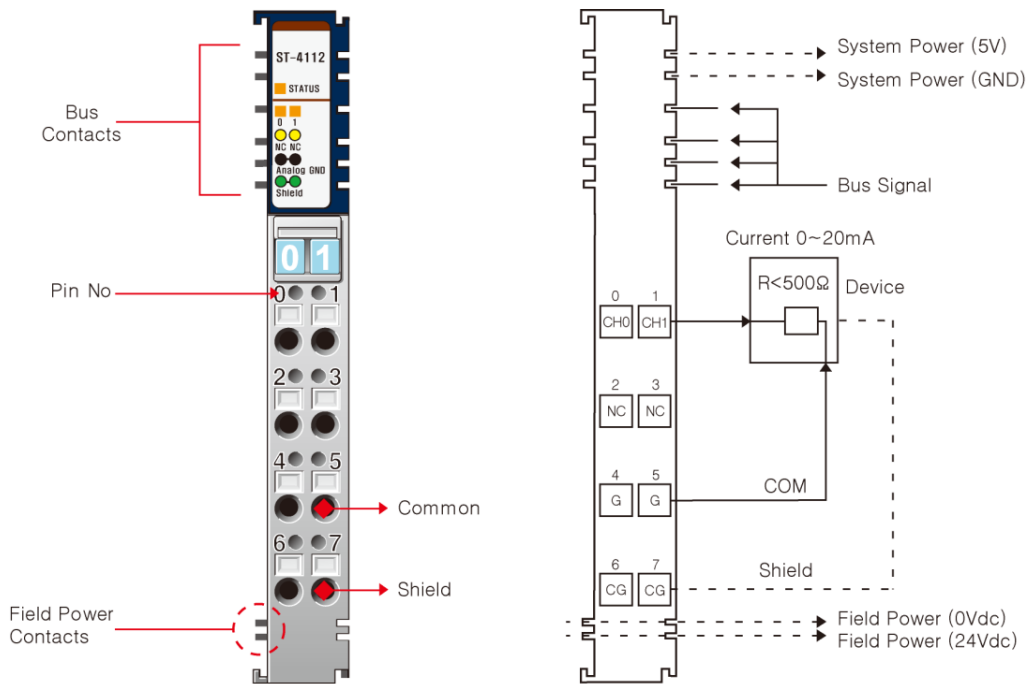

Figure 79: Analog Output Module: ST-4112

The following table lists the pin numbers and its description for ST-4112.

Table 143: ST-4112: Pin Description

Pin Number	Description	Pin Number	Description
0	Output Channel 0	1	Output Channel 1
2	No Connection	3	No Connection
4	Output Channel Common (0V)	5	Output Channel Common (0V)
6	Chassis Ground/Shield	7	Chassis Ground/Shield

Specification

The following table describes the Output Specifications and the General Specifications for ST-4112.

Table 144: ST-4112: Output and General Specifications

Items	Specification
Output Specification	
Outputs Per Module	2 Channels single ended, Non-isolated between channels
Indicators	2 Green States, 1 Green/Red RSTi Bus State
Resolution in Ranges	12 bits: 4.88uA/Bit
Output Current Range	0 ~ 20mA
Data Format	16 bits Integer (2's complement)
Module Error	±0.1% Full Scale @25°C ±0.3% Full Scale @0°C, 60°C
Load Resistance	Maximum 500Ω
Conversion Time	2msec/All channel
Calibration	Not Required
Diagnostic	No
Common Type	2 Channels/2 COM (Single Channel)
General Specification	
Power Dissipation	Maximum 60mA @ 5.0Vdc
Isolation	I/O to Logic: Photo coupler Isolation Field power: Non-isolation
Field Power	Supply Voltage: 24Vdc nominal Voltage Range: 15~28.8Vdc Power Dissipation: Maximum 60mA @24Vdc
Wiring	I/O Cable Maximum 2.0mm ²
Weight	70g
Module Size	12mm x 99mm x 70mm
Environment Condition	See "Environmental Specifications" in Appendix A.

ST-4114

Interface and Data

The following illustration shows the interface design for ST-4114.

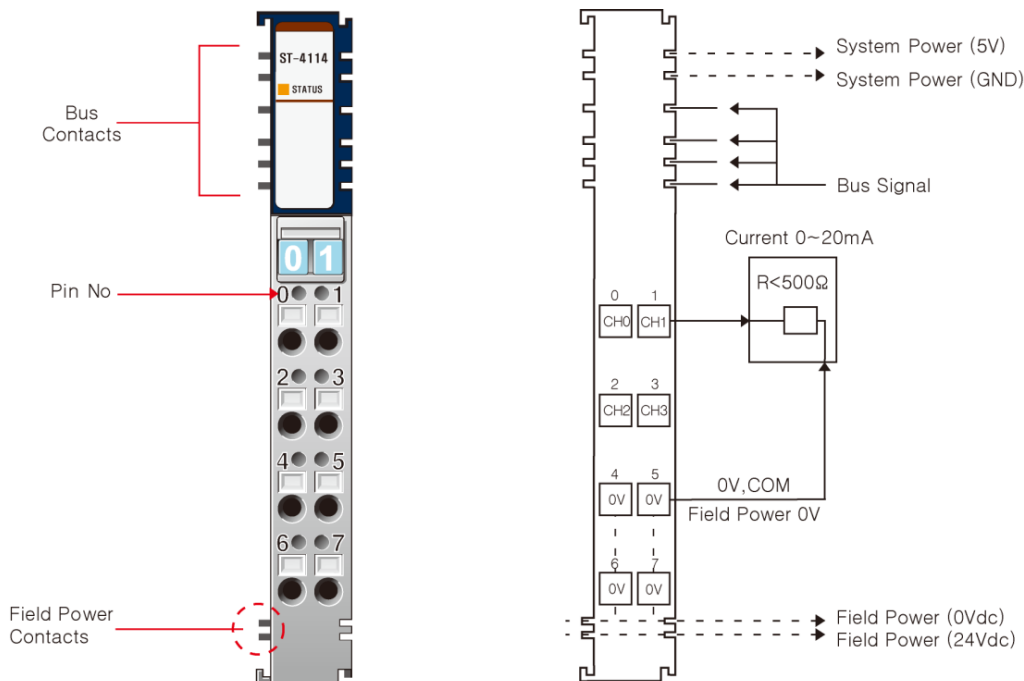

Figure 80: Analog Output Module: ST-4114

The following table lists the pin numbers and its description for ST-4114.

Table 145: ST-4114: Pin Description

Pin Number	Description	Pin Number	Description
0	Output Channel 0	1	Output Channel 1
2	Output Channel 2	3	Output Channel 3
4	Field Ground 0V (AGND), Common	5	Field Ground 0V (AGND), Common
6	Field Ground 0V (AGND), Common	7	Field Ground 0V (AGND), Common

Specification

The following table describes the Output Specifications and the General Specifications for ST-4114.

Table 146: ST-4114: Output and General Specifications

Items	Specification
Output Specification	
Outputs Per Module	4 Channels single ended
Indicators	1 Green/Red RSTi Bus State
Resolution in Ranges	12 bits: 4.88uA/Bit
Output Current Range	0 ~ 20mA
Data Format	16 bits Integer (2's complement)
Module Error	±0.1% Full Scale @25°C (100uA~20mA) ±0.25% Full Scale @25°C (0uA~100uA) ±0.3% Full Scale @0°C, 60°C
Load Resistance	Maximum 500Ω
Conversion Time	4msec/All channel
Calibration	Not Required
Diagnostic	No
Common Type	4 Common, Field Power 0V is Common(AGND)
General Specification	
Power Dissipation	Maximum 60mA @ 5.0Vdc
Isolation	I/O to Logic: Photo coupler Isolation Field power: Non-isolation
Field Power	Supply Voltage: 24Vdc nominal Voltage Range: 18~28.8Vdc Power Dissipation: Maximum 60mA @24Vdc
Wiring	I/O Cable Maximum 2.0mm ²
Weight	70g
Module Size	12mm x 99mm x 70mm
Environment Condition	See "Environmental Specifications" in Appendix A.

ST-4212

Interface and Data

The following illustration shows the interface design for ST-4212.

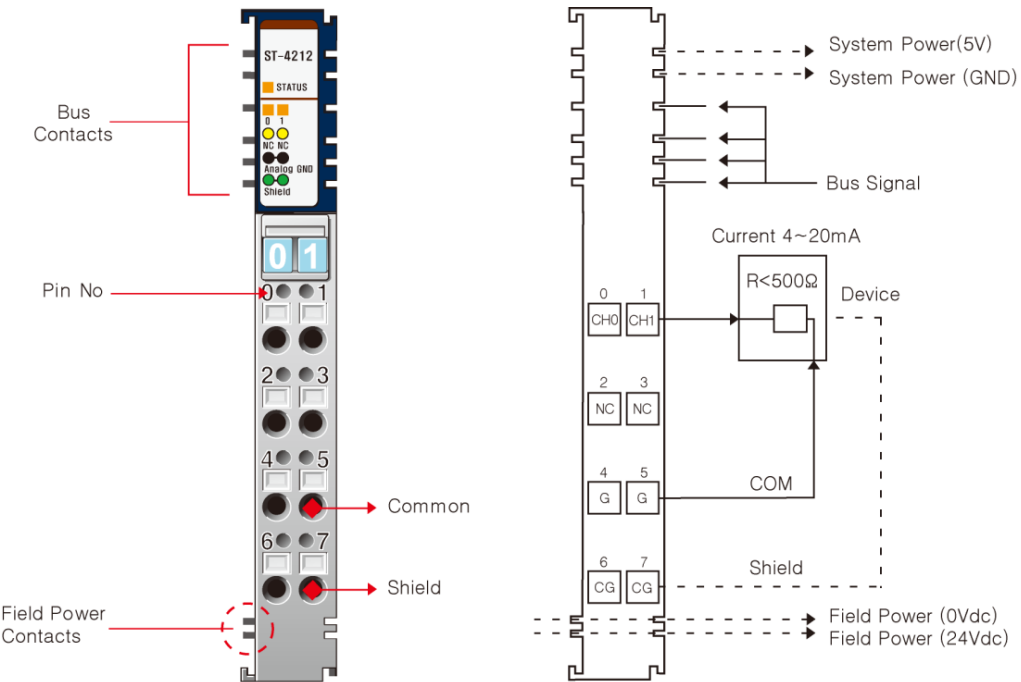

Figure 81: Analog Output Module: ST-4212

The following table lists the pin numbers and its description for ST-4212.

Table 147: ST-4212: Pin Description

Pin Number	Description	Pin Number	Description
0	Output Channel 0	1	Output Channel 1
2	No Connection	3	No Connection
4	Output Channel Common (0V)	5	Output Channel Common (0V)
6	Chassis Ground/Shield	7	Chassis Ground/Shield

Specification

The following table describes the Output Specifications and the General Specifications for ST-4212.

Table 148: ST-4212: Output and General Specifications

Items	Specification
Output Specification	
Outputs Per Module	2 Channels single ended, Non-isolated between channels
Indicators	2 Green States, 1 Green/Red RSTi Bus State
Resolution in Ranges	12 bits: 3.9uA/Bit
Output Current Range	4 ~ 20mA
Data Format	16 bits Integer (2's complement)
Module Error	±0.1% Full Scale @25°C ±0.3% Full Scale @0°C, 60°C
Load Resistance	Maximum 500Ω
Conversion Time	2msec/All channel
Calibration	Not Required
Diagnostic	No
Common Type	2 Channels/2 COM (Single Channel)
General Specification	
Power Dissipation	Maximum 60mA @ 5.0Vdc
Isolation	I/O to Logic: Photo coupler Isolation Field power: Non-isolation
Field Power	Supply Voltage: 24Vdc nominal Voltage Range: 15~28.8Vdc Power Dissipation: Maximum 60mA @24Vdc
Wiring	I/O Cable Maximum 2.0mm ²
Weight	70g
Module Size	12mm x 99mm x 70mm
Environment Condition	See "Environmental Specifications" in Appendix A.

ST-4214

Interface and Data

The following illustration shows the interface design for ST-4214.

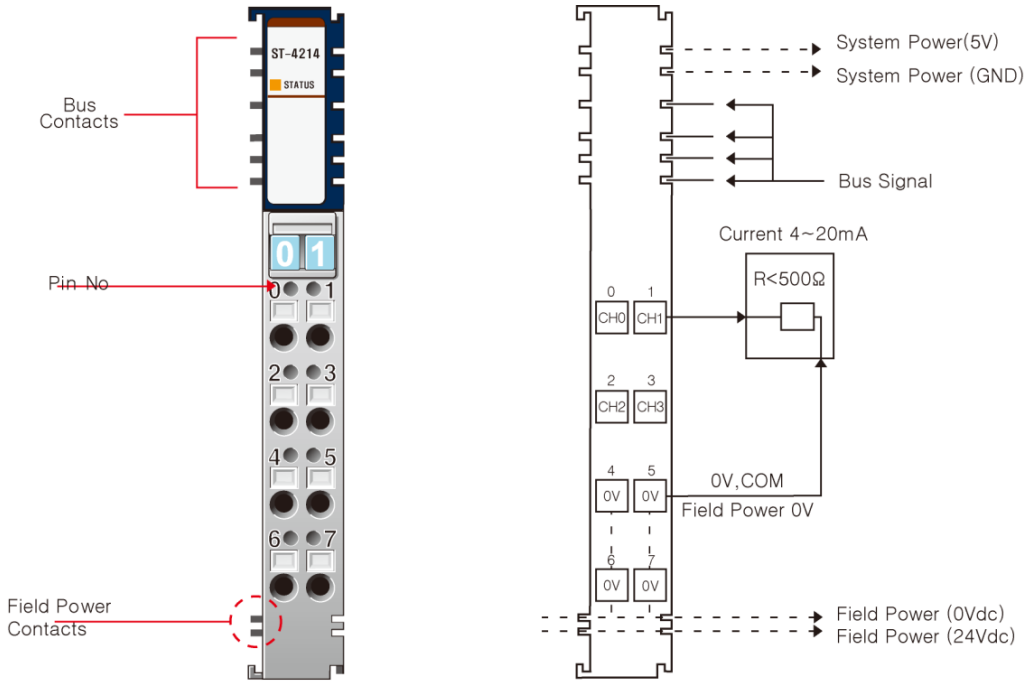

Figure 82: Analog Output Module: ST-4214

The following table lists the pin numbers and its description for ST-4214.

Table 149: ST-4214: Pin Description

Pin Number	Description	Pin Number	Description
0	Output Channel 0	1	Output Channel 1
2	Output Channel 2	3	Output Channel 3
4	Field Ground 0V (AGND), Common	5	Field Ground 0V (AGND), Common
6	Field Ground 0V (AGND), Common	7	Field Ground 0V (AGND), Common

Specification

The following table describes the Output Specifications and the General Specifications for ST-4214.

Table 150: ST-4214: Output and General Specifications

Items	Specification
Output Specification	
Outputs Per Module	4 Channels single ended
Indicators	1 Green/Red RSTi Bus State
Resolution in Ranges	12 bits: 3.9uA/Bit
Output Current Range	4 ~ 20mA
Data Format	16 bits Integer (2'compliment)
Module Error	±0.1% Full Scale @25°C ±0.3% Full Scale @0°C, 60°C
Load Resistance	Maximum 500Ω
Conversion Time	4msec/All channel
Calibration	Not Required
Diagnostic	No
Common Type	4 Common, Field Power 0V is Common (AGND)
General Specification	
Power Dissipation	Maximum 60mA @ 5.0Vdc
Isolation	I/O to Logic: Photo coupler Isolation Field power: Non-isolation
Field Power	Supply Voltage: 24Vdc nominal Voltage Range: 18~28.8Vdc Power Dissipation: Maximum 60mA @24Vdc
Wiring	I/O Cable Maximum 2.0mm ²
Weight	70g
Module Size	12mm x 99mm x 70mm
Environment Condition	See "Environmental Specifications" in Appendix A.

ST-4422

Interface and Data

The following illustration shows the interface design for ST-4422.

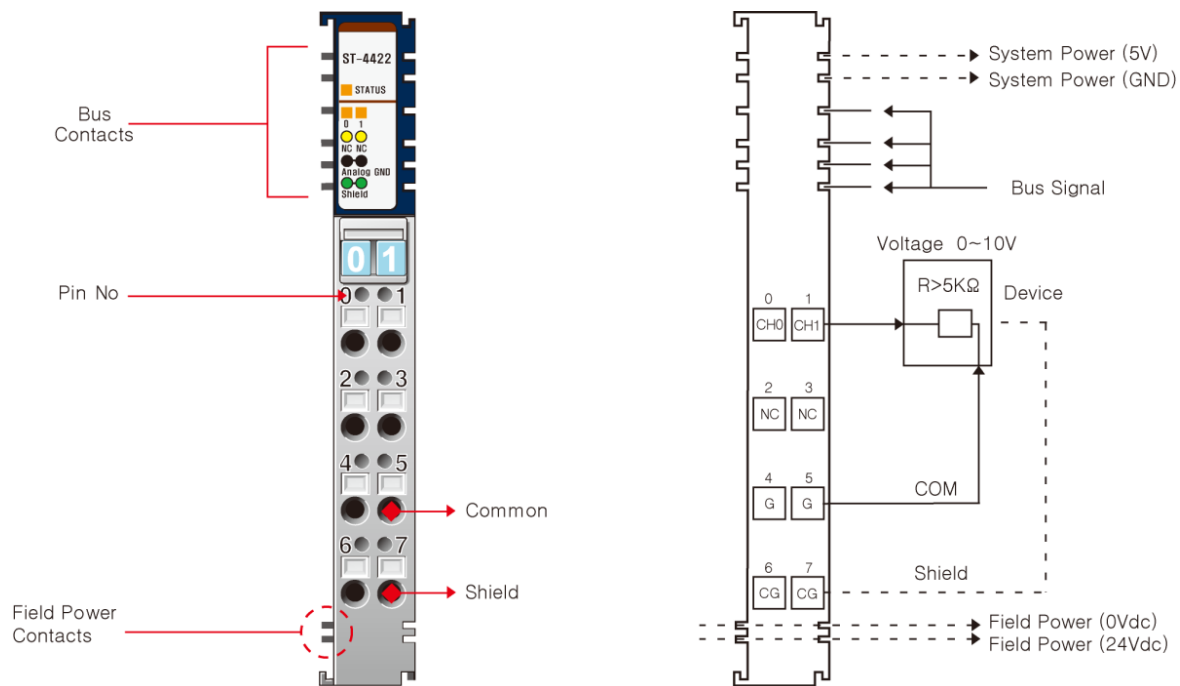

Figure 83: Analog Output Module: ST-4422

The following table lists the pin numbers and its description for ST-4422.

Table 151: ST-4422: Pin Description

Pin Number	Description	Pin Number	Description
0	Output Channel 0	1	Output Channel 1
2	No Connection	3	No Connection
4	Output Channel Common (0V)	5	Output Channel Common (0V)
6	Chassis Ground/Shield	7	Chassis Ground/Shield

Specification

The following table describes the Output Specifications and the General Specifications for ST-4422.

Table 152: ST-4422: Output and General Specifications

Items	Specification
Output Specification	
Outputs Per Module	2 Channels single ended, Non-isolated between channel
Indicators	2 Green States, 1 Green/Red RSTi Bus State
Resolution in Ranges	12 bits: 2.44mV/Bit
Output Voltage Range	0 ~ 10Vdc
Data Format	16 bits Integer (2's complement)
Module Error	±0.1% Full Scale @25°C ±0.3% Full Scale @0°C , 60°C
Load Resistance	Minimum 5kΩ
Conversion Time	2msec/All Channel
Calibration	Not Required
Diagnostic	No
Common Type	2 Channels/2 COM (Single Common)
General Specification	
Power Dissipation	Maximum 155mA @ 5.0Vdc
Power Supply	From System Power DC/DC
Isolation	I/O to Logic: Photo coupler Isolation Field power: Not Connected
Wiring	I/O Cable Maximum 2.0mm ²
Weight	70g
Module Size	12mm x 99mm x 70mm
Environment Condition	See "Environmental Specifications" in Appendix A.

ST-4424

Interface and Data

The following illustration shows the interface design for ST-4424.

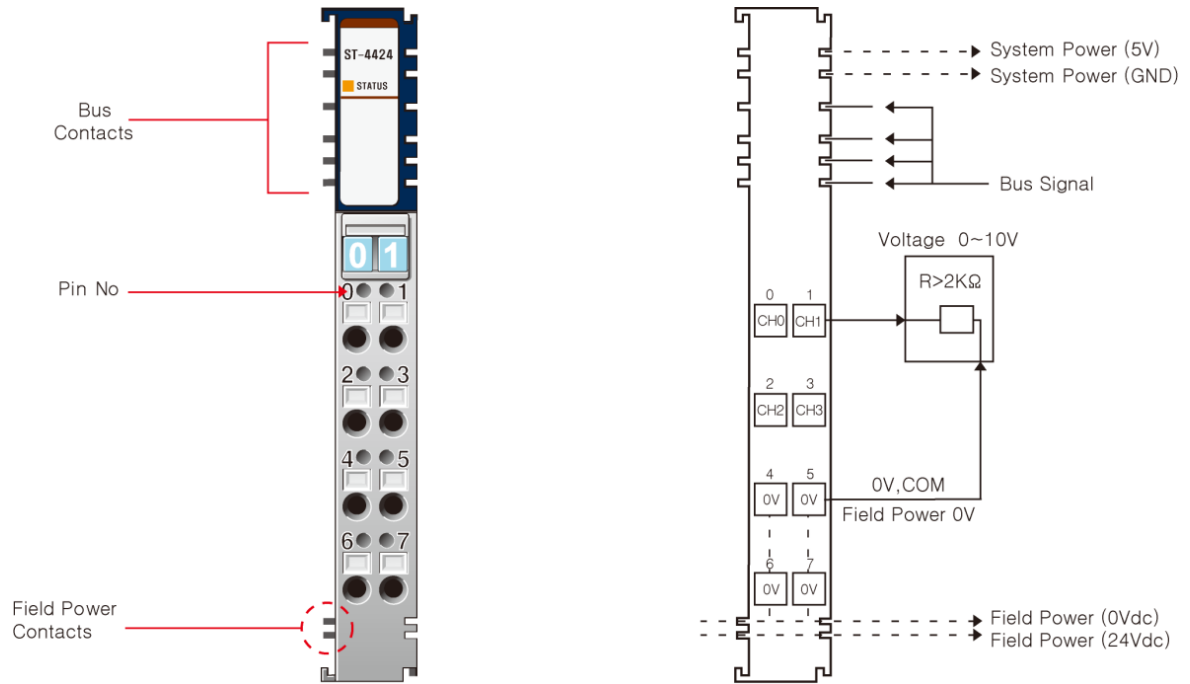

Figure 84: Analog Output Module: ST-4424

The following table lists the pin numbers and its description for ST-4424.

Table 153: ST-4424: Pin Description

Pin Number	Description	Pin Number	Description
0	Output Channel 0	1	Output Channel 1
2	Output Channel 2	3	Output Channel 3
4	Field Ground 0V (AGND), Common [†]	5	Field Ground 0V (AGND), Common [†]
6	Field Ground 0V (AGND), Common [†]	7	Field Ground 0V (AGND), Common [†]

[†] All field grounds are connected internally.

Specification

The following table describes the Output Specifications and the General Specifications for ST-4424.

Table 154: ST-4424: Output and General Specifications

Items	Specification
Output Specification	
Outputs Per Module	4 Channels single ended
Indicators	1 Green/Red RSTi Bus State
Resolution in Ranges	12 bits: 2.44mV/Bit
Output Voltage Range	0 ~ 10Vdc
Data Format	16 bits Integer (2's complement)
Module Error	±0.1% Full Scale @25°C ±0.3% Full Scale @-20°C, 60°C,
Load Resistance	Minimum 2kΩ
Conversion Time	4msec/All channel
Calibration	Not Required
Diagnostic	No
Common Type	4 Common, Field Power 0V is Common (AGND)
General Specification	
Power Dissipation	Maximum 60mA @ 5.0Vdc
Isolation	I/O to Logic: Photo coupler Isolation Field power: Non-isolation
Field Power	Supply Voltage: 24Vdc nominal Voltage Range: 18~28.8Vdc Power Dissipation: Maximum 60mA @24Vdc
Wiring	I/O Cable Maximum 2.0mm ² (AWG#14)
Weight	70g
Module Size	12mm x 99mm x 70mm
Environment Condition	See "Environmental Specifications" in Appendix A.

ST-4491

Interface and Data

The following illustration shows the interface design for ST-4491.

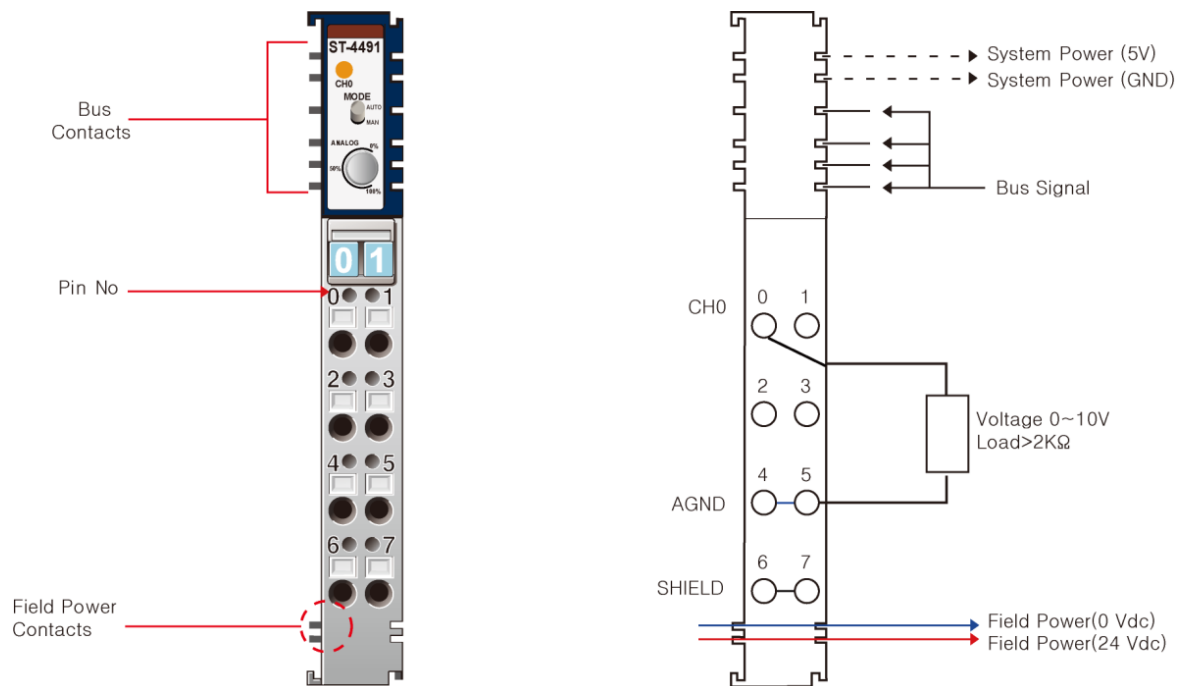

Figure 85: Analog Output Module: ST-4491

The following table lists the pin numbers and its description for ST-4491.

Table 155: ST-4491: Pin Description

Pin Number	Description	Pin Number	Description
0	Output Channel 0	1	-
2	-	3	-
4	AGND	5	AGND
6	Shield	7	Shield

Switch Mode

Table 156: ST-4491: Switch Mode

Switch is	Status	Description
Auto Manual	Auto Manual for Ch0	Ch0 Analog Output varies according to the potentiometer

Specification

The following table describes the Output Specifications and the General Specifications for ST-4491.

Table 157: ST-4491: Output and General Specifications

Items	Specification
Output Specification	
Outputs Per Module	1 Channels single ended
Indicators	1 Green/Red RSTi Bus State
Resolution in Ranges	12 bits: 2.44mV/Bit
Output Voltage Range	0 ~ 10Vdc
Data Format	16 bits Integer (2's complement)
Module Error	±0.1% Full Scale @25°C ±0.3% Full Scale @-20°C, 60°C,
Load Resistance	Minimum 2kΩ
Conversion Time	1.2msec/All channel
Calibration	Not Required
Diagnostic	No
Common Type	2 Common/Module
General Specification	
Power Dissipation	Maximum 60mA @ 5.0Vdc
Isolation	I/O to Logic: Photo coupler Isolation
Field Power	Not used, Field Power by pass to next expansion module
Wiring	I/O Cable Maximum 2.0mm ² (AWG#14)
Weight	70g
Module Size	12mm x 99mm x 70mm
Environment Condition	See "Environmental Specifications" in Appendix A.

ST-4522

Interface and Data

The following illustration shows the interface design for ST-4522.

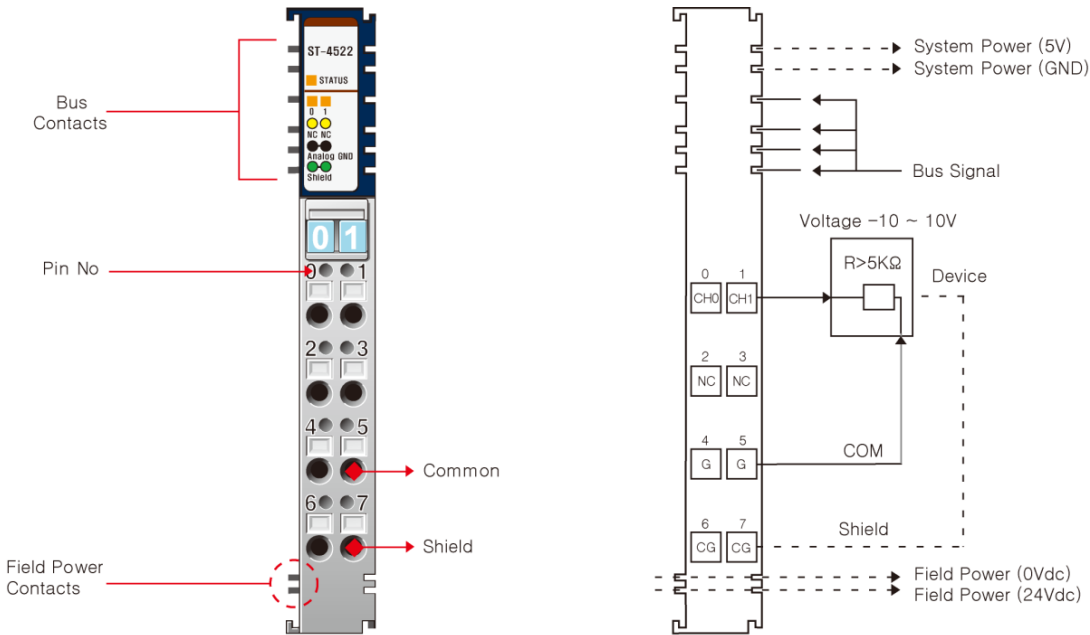

Figure 86: Analog Output Module: ST-4522

The following table lists the pin numbers and its description for ST-4522.

Table 158: ST-4522: Pin Description

<i>Pin Number</i>	<i>Description</i>	<i>Pin Number</i>	<i>Description</i>
0	Output Channel 0	1	Output Channel 1
2	No Connection	3	No Connection
4	Output Channel Common (0V)	5	Output Channel Common (0V)
6	Chassis Ground/Shield	7	Chassis Ground/Shield

Specification

The following table describes the Output Specifications and the General Specifications for ST-4522.

Table 159: ST-4522: Output and General Specifications

Items	Specification
Output Specification	
Outputs Per Module	2 Channels single ended, Non-isolated between channel
Indicators	2 Green States, 1 Green/Red RSTi Bus State
Resolution in Ranges	12 bits: 4.88mV/Bit
Output Voltage Range	-10 ~ 10Vdc
Data Format	16 bits Integer (2's complement)
Module Error	±0.1% Full Scale @25°C ±0.3% Full Scale @-20°C, 60°C,
Load Resistance	Minimum 5kΩ
Conversion Time	2msec/All channel
Calibration	Not Required
Diagnostic	No
Common Type	2 Channels/2COM (Single common)
General Specification	
Power Dissipation	Maximum 155mA @ 5.0Vdc
Isolation	I/O to Logic: Photo coupler Isolation I/O to Field Power: Not Connected
Power Supply	From System Power DC/DC
Wiring	I/O Cable Maximum 2.0mm ² (AWG#14)
Weight	70g
Module Size	12mm x 99mm x 70mm
Environment Condition	See "Environmental Specifications" in Appendix A.

ST-4622

Interface and Data

The following illustration shows the interface design for ST-4622.

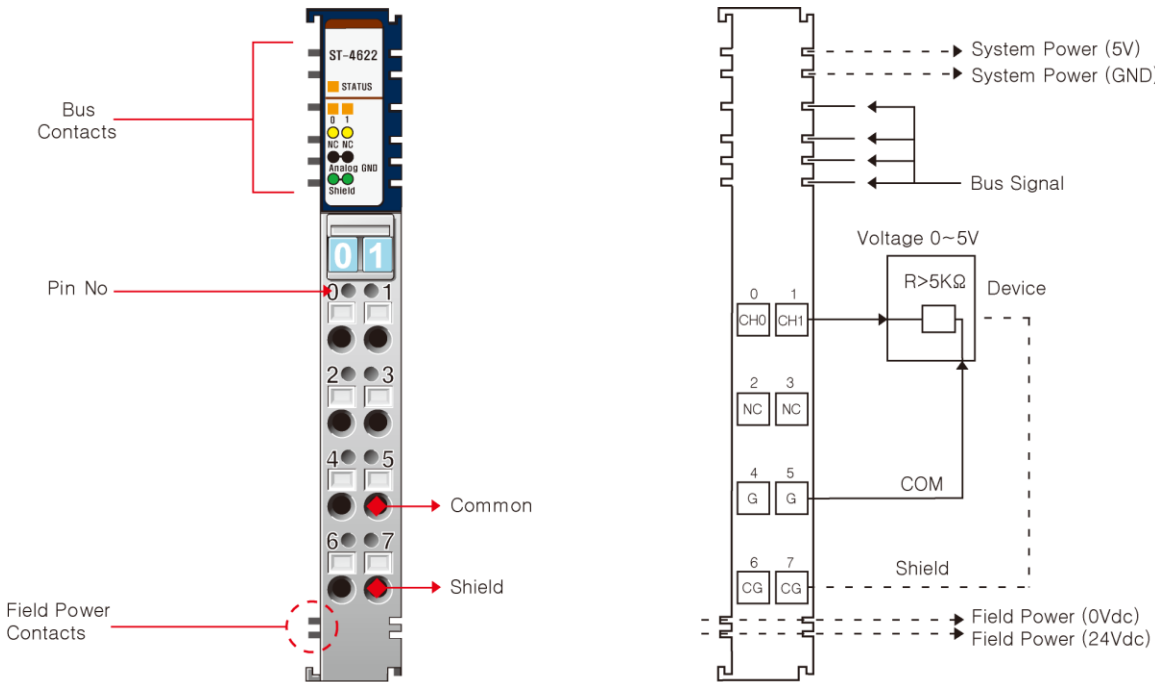

Figure 87: Analog Output Module: ST-4622

The following table lists the pin numbers and its description for ST-4622.

Table 160: ST-4622: Pin Description

<i>Pin Number</i>	<i>Description</i>	<i>Pin Number</i>	<i>Description</i>
0	Output Channel 0	1	Output Channel 1
2	No Connection	3	No Connection
4	Output Channel Common (0V)	5	Output Channel Common (0V)
6	Chassis Ground/Shield	7	Chassis Ground/Shield

Specification

The following table describes the Output Specifications and the General Specifications for ST-4622.

Table 161: ST-4622: Output and General Specifications

Items	Specification
Output Specification	
Outputs Per Module	2 Channels single ended, Non-isolated between channel
Indicators	2 Green States, 1 Green/Red RSTi Bus State
Resolution in Ranges	12 bits: 1.22mV/Bit
Output Voltage Range	0 ~ 5Vdc
Data Format	16 bits Integer (2's complement)
Module Error	±0.1% Full Scale @25°C ±0.3% Full Scale @-20°C, 60°C,
Load Resistance	Minimum 5kΩ
Conversion Time	2msec/All channel
Calibration	Not Required
Diagnostic	No
Common Type	2Channels/2COM (Single common)
General Specification	
Power Dissipation	Maximum 155mA @ 5.0Vdc
Isolation	I/O to Logic: Photo coupler Isolation I/O to Field Power: Not Connected
Power Supply	From System Power DC/DC
Wiring	I/O Cable Maximum 2.0mm ² (AWG#14)
Weight	70g
Module Size	12mm x 99mm x 70mm
Environment Condition	See "Environmental Specifications" in Appendix A.

ST-4911

Interface and Data

The following illustration shows the interface design for ST-4911.

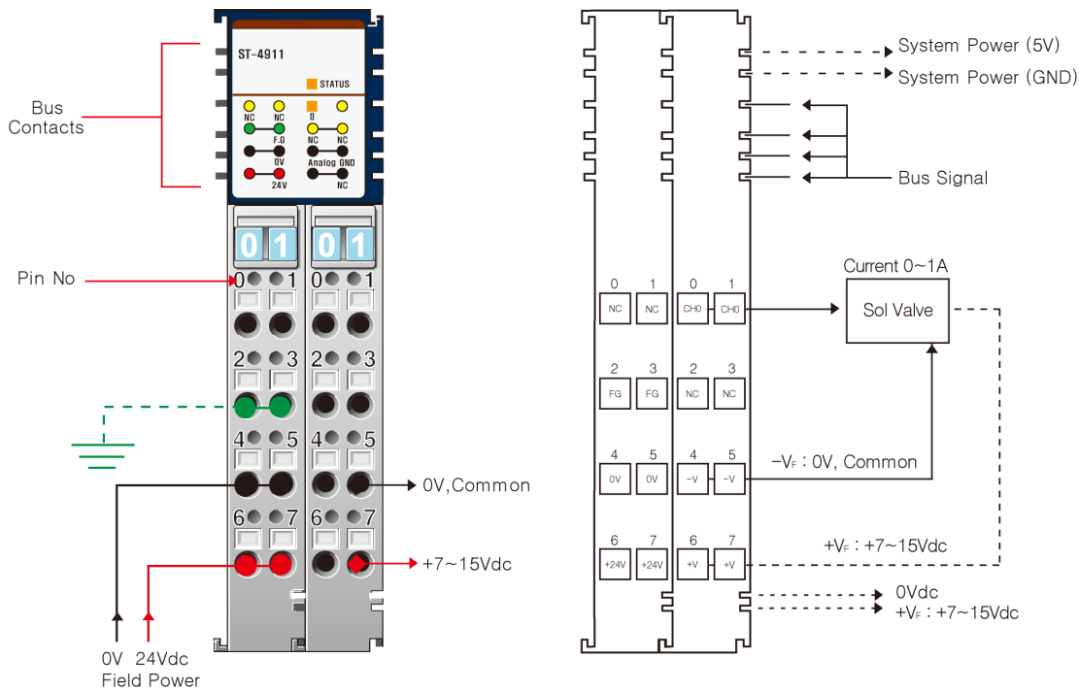

Figure 88: Analog Output Module: ST-4911

Signal for Left Terminal

The following table lists the pin numbers and their description for ST-4911 Left Terminal.

Table 162: ST-4911: Pin Description for Left Terminal

Pin Number	Description	Pin Number	Description
0	No Connector	1	No Connector
2	FG	3	FG
4	Field Ground (0V), Common	5	Field Ground (0V), Common
6	Field Power (+24V)	7	Field Power (+24V)

Signal for Right Terminal

The following table lists the pin numbers and their description for ST-4911 Right Terminal.

Table 163: ST-4911: Pin Description for Right Terminal

Pin Number	Description	Pin Number	Description
0	Output Channel 0	1	Output Channel 0
2	No Connector	3	No Connector
4	0V, Common	5	0V, Common
6	+7~15V	7	+7~15V

Specification

The following table describes the Output Specifications and the General Specifications for ST-4911.

Table 164: ST-4911: Output and General Specifications

Items	Specification
Output Specification	
Outputs Per Module	1 Channel single ended, Non-isolated
Indicators	1 Green RSTi Bus State, 1 Green/Red Output Channel State
Resolution in Ranges	12 bits: 2.44mV/Bit
Output Current Range	0 ~ 1 A
Data Format	16 bits Integer (2's complement)
Module Error	±0.1% Full Scale @25°C ±0.3% Full Scale @-20°C, 60°C,
Load Resistance	13Ω, ±5%
Conversion Time	1msec/All channel
Calibration	Not Required
Diagnostic	No
Common Type	1 Channel/2Common (Field Power 0V)
General Specification	
Power Dissipation	Maximum 60mA @ 5.0Vdc
Isolation	I/O to Logic: Photo coupler Isolation I/O to Field Power: Non-Isolation
Field Power	Supply Voltage: 24Vdc nominal Voltage Range: 15~28Vdc Power Dissipation: Maximum 60mA@24Vdc
Wiring	I/O Cable Maximum 2.0mm ² (AWG#14)
Weight	140g
Module Size	24mm x 99mm x 70mm
Environment Condition	See "Environmental Specifications" in Appendix A.

Dimension

ST-4xx1, ST-4xx2, and ST-4xx4

The following illustration shows the dimensions for ST-4xx1, ST-4xx2, and ST-4xx4 series.

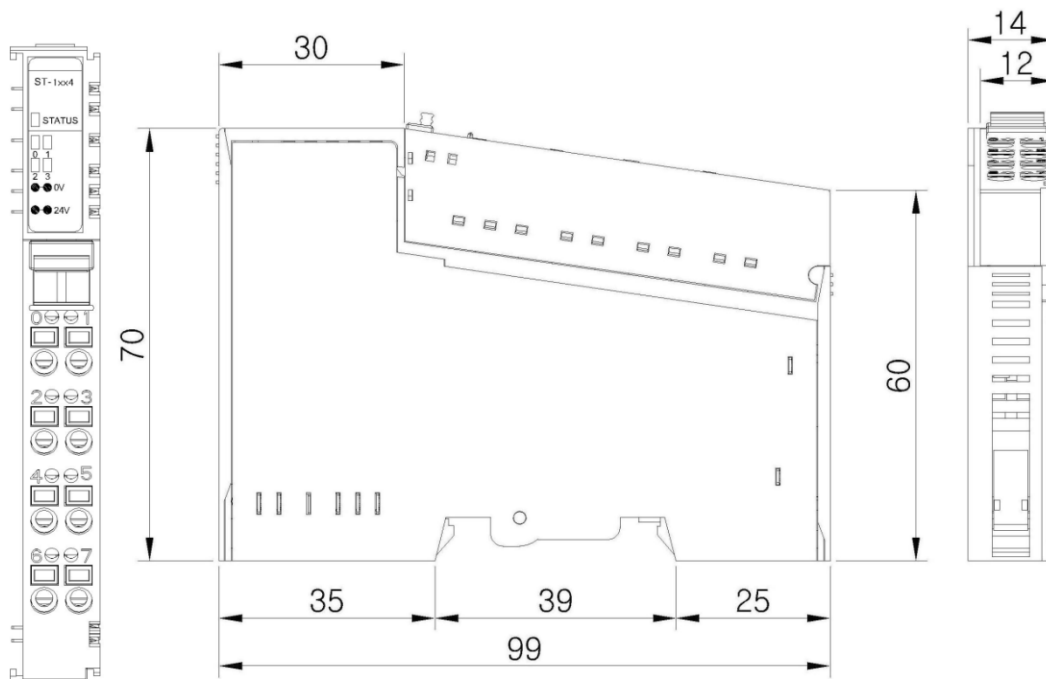

Figure 89: ST-4xx1, ST-4xx2, and ST-4xx4 Dimensions

Mapping Data into the Image Table

ST-4xx2

Output Module Data

Analog output Ch 0
Analog output Ch 1



Output Image Value

Bit No	Bit7	Bit6	Bit5	Bit4	Bit3	Bit2	Bit1	Bit0
Byte 0	Analog Output Ch 0 Low byte							
Byte 1	Analog Output Ch 0 High byte							
Byte 2	Analog Output Ch 1 Low byte							
Byte 3	Analog Output Ch 1 High byte							

ST-4xx4

Output Module Data

Analog output Ch 0
Analog output Ch 1
Analog output Ch 2
Analog output Ch 3



Output Image Value

Bit No	Bit7	Bit6	Bit5	Bit4	Bit3	Bit2	Bit1	Bit0
Byte 0	Analog output Ch 0 Low byte							
Byte 1	Analog output Ch 0 High byte							
Byte 2	Analog output Ch 1 Low byte							
Byte 3	Analog output Ch 1 High byte							
Byte 4	Analog output Ch 2 Low byte							
Byte 5	Analog output Ch 2 High byte							
Byte 6	Analog output Ch 3 Low byte							
Byte 7	Analog output Ch 3 High byte							

ST-4991

Output Module Data

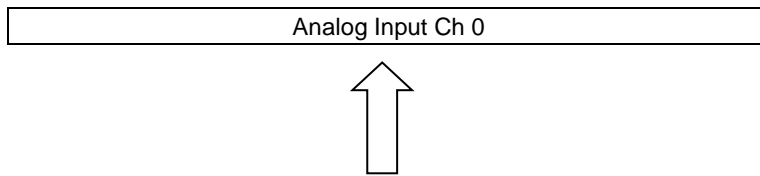

Output Image Value

Bit No	Bit7	Bit6	Bit5	Bit4	Bit3	Bit2	Bit1	Bit0
Byte 0	Analog Input Ch 0 Low byte							
Byte 1	Analog Input Ch 0 High byte							

ST-4491

Input Image Value

Byte	Bit7	Bit6	Bit5	Bit4	Bit3	Bit2	Bit1	Bit0
Byte 0	-	-	-	-	-	-	-	Ch#0
	Auto/manual detection 0b : Ch# Auto 1b : Ch#0 Manual							
Byte 1	Reserved							
Byte 2	Ch#0 Manual Low byte							
Byte 3	Ch#0 Manual High byte							

Output Image Value

Bit No	Bit7	Bit6	Bit5	Bit4	Bit3	Bit2	Bit1	Bit0
Byte 0	Ch#0 Conversion Data Low byte							
Byte 1	Ch#0 Conversion Data High byte							

Configuration Parameter Data

Byte	Bit7	Bit6	Bit5	Bit4	Bit3	Bit2	Bit1	Bit0
Byte 0	-	-	-	-	-	-	Ch#0 Fault Action	
	Fault Action 00b : Fault Value 01b : Hold Last Value 10b : Low Limit 11b : High Limit							

Byte 1	Reserved
Byte 2	Ch#0 Manual Low byte
Byte 3	Ch#0 Manual High byte

Current and Voltage Mode

ST-4112 and ST-4114

The following table lists the Current range for ST-4112 and ST-4114.

Table 165: ST-4112 and ST-4114: Output Current Range

Current	0.0mA	5.0mA	10.0mA	20.0mA
Data(Hex)	H 0000	H 03FF	H 07FF	H 0FFF

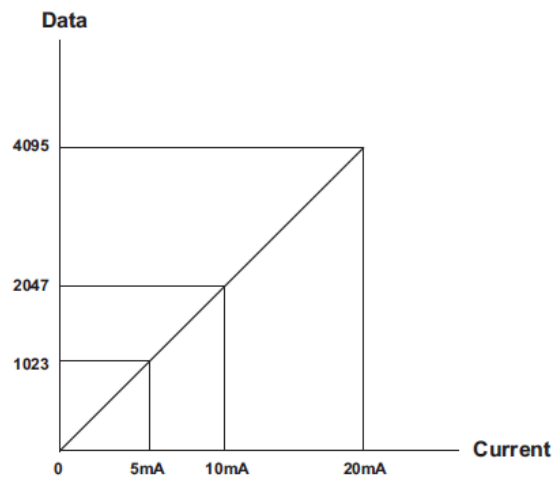

ST-4212

The following table lists the Current range for ST-4212.

Table 166: ST-4212: Output Current Range

Current	4.0mA	5.0mA	10.0mA	20.0mA
Data(Hex)	H 0000	H 00FF	H 05FF	H 0FFF

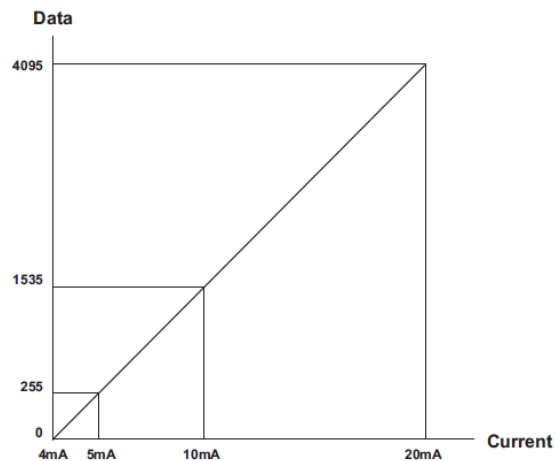

ST-4214

The following table lists the Current range for ST-4214.

Table 167: ST-4214: Output Current Range

Current	4.0mA	8.0mA	12.0mA	20.0mA
Data(Hex)	H 0000	H 03FF	H 07FF	H 0FFF

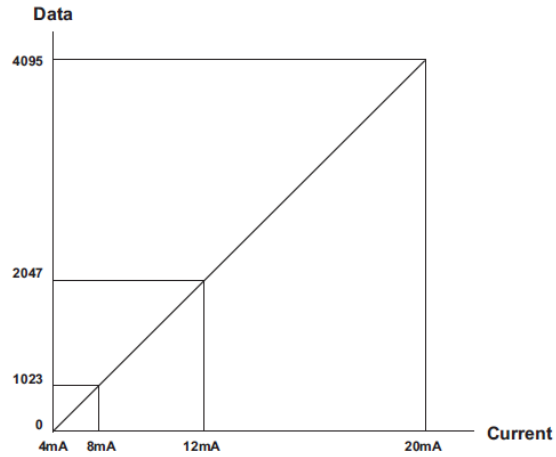

ST-4422, ST-4424, and ST-4491

The following table lists the Voltage range for ST-4422, ST-4424, and ST-4491.

Table 168: ST-4422, ST-4424, and ST-4491: Output Voltage Range

Voltage	0V	2.5V	5V	10V
Data(Hex)	H 0000	H 03FF	H 07FF	H 0FFF

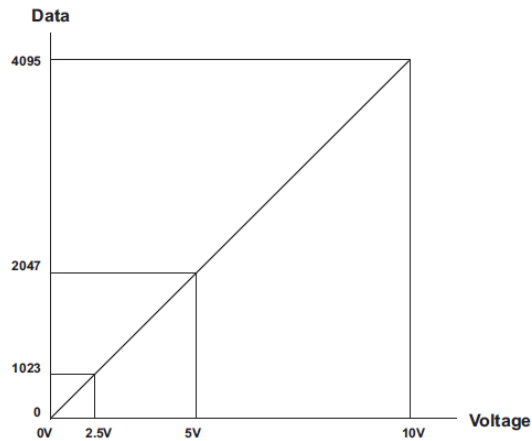

ST-4474

The following table lists the Voltage range for ST-4474.

Table 169: ST-4474: Output Voltage Range

Voltage	0V	2.5V	5V	10V
Data(Hex)	H 0000	H 03FF	H 07FF	H 0FFF

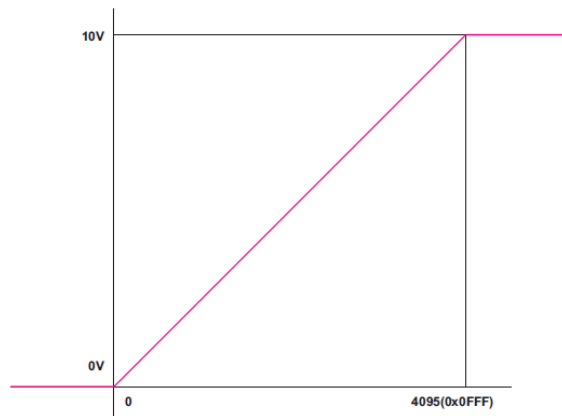

ST-4522

The following table lists the Voltage range for ST-4522.

Table 170: ST-4522: Output Voltage Range

Voltage	-10V	-5V	0V	5V	10V
Data(Hex)	H F800	H FC00	H 0000	H 03FF	H 07FF

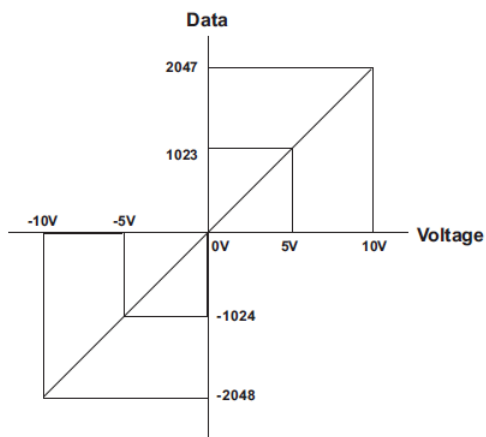

ST-4622

The following table lists the Voltage range for ST-4622.

Table 171: ST-4622: Output Voltage Range

Voltage	0V	2V	4V	5V
Data(Hex)	H 0000	H 0666	H 0CCC	H 0FFF

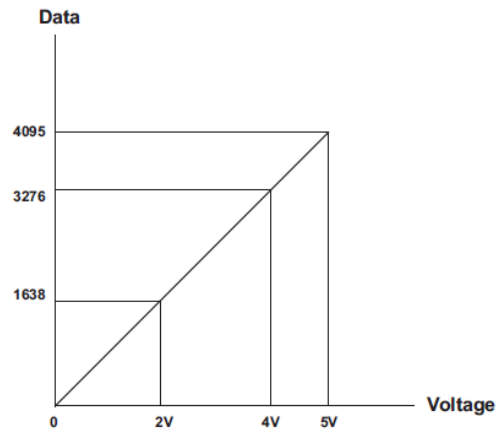

ST-4911

The following table lists the Current range for ST-4911.

Table 172: ST-4911: Output Current Range

Current	0A	0.25A	0.5A	1A
Data(Hex)	H 0000	H 03FF	H 07FF	H 0FFF

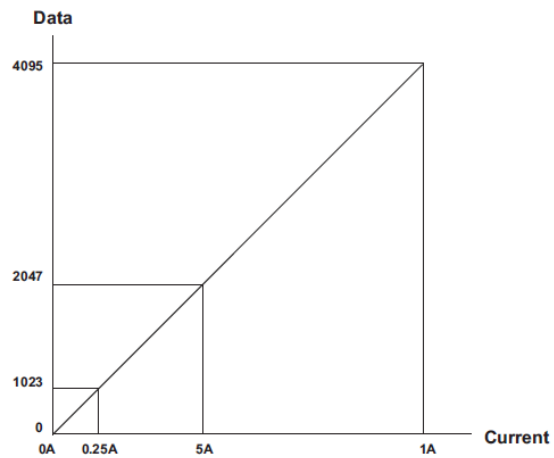

Diagnostics

Normal Module

The LEDs indicate the status of the module. The table below shows the corresponding functions of LEDs during normal operation. You can use this table as a reference for troubleshooting errors.

Table 173: Normal Module

Color	Status	Function
IO Modules Status LED		
Off	Not Power No Initialized	Device has no expansion Module or may not be powered The Parameter is not initialized yet.
Solid Green	RSTi Bus Connection	RSTi Bus Normal Operation
Flashing Green	RSTi Bus Ready	RSTi Bus Ready
Flashing Red	RSTi Bus Fault	RSTi Bus Time Out, RSTi Bus Failed Communication
Solid Red	Device Fault	Device fault
Channel Status LED		
Off	No Signal	Normal Operation
Solid Green	On Signal	Normal Operation

Note: For more help on troubleshooting errors related to Network Adaptor and its protocols, please refer to Network Adaptor User Manual.

Special Modules include:

- 1/2/4 channel High Speed Counter; each module has 5VDC and 24 VDC.
- 1/2 channel Serial Communication; each module supports RS232, RS422, and RS485
- 2/4 channel PWM; each module has 0.5A and 2A.
- 1/2 channel 24VDC Pulse output.

High Speed Counter Modules

ST-5101

Interface and Data

The following illustration shows the interface design for ST-5101.

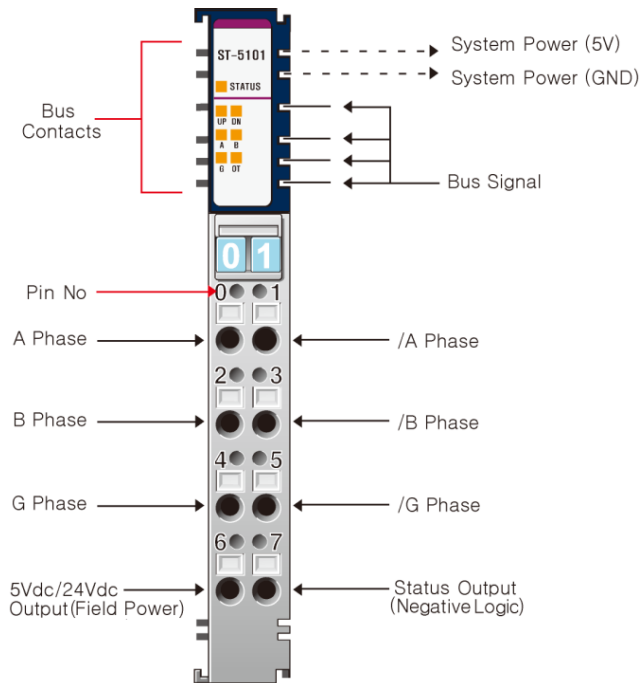
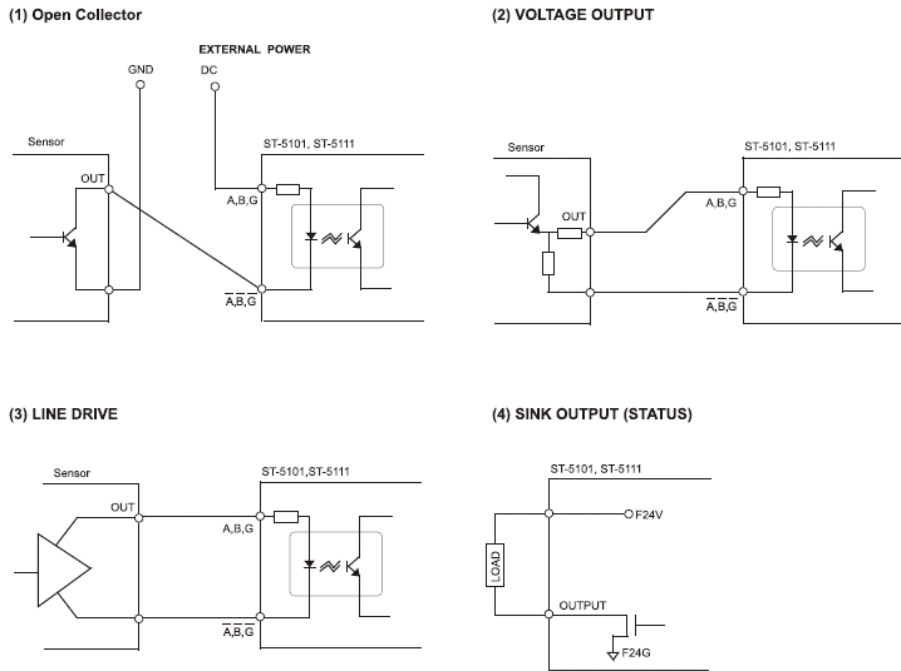

Figure 90: High Speed Counter Module: ST-5101



Specification

The following table describes the Input Specifications, Output Specifications, and the General Specifications for ST-5101.

Table 174: ST-5101: Input, Output and General Specifications

Items	Specification
Input Specification	
Input Voltage	5Vdc
Input Current	16.2mA @ 5Vdc
Input. On-State Current	Input Current \geq 5mA
Input Off-State Voltage	Input Voltage \geq 2.6Vdc
Output On-State Current	Input Current \leq 0.25mA
Output On-State Voltage	Input Voltage \leq 1.25Vdc
Maximum On-State Voltage	6V
Maximum Input Frequency	Maximum 1.5MHz
Input Filter Selections	Bypass 1usec 5usec 10usec 50usec 100usec 500usec 1msec 5msec 10msec

Number of Inputs	1-2 group of A and /A(or GND) 3-4 group of B and /B(or GND) 5-6 group of G and /G(or GND)
Output Specification	
Number of Outputs	7-8 States Output
Output Control	Output and be tied to any of 13 State
Output Supply Voltage Range	5 to 28.8Vdc (HSC Status Output)
On State Voltage Drop	Maximum 0.3Vdc
On State Current	Maximum 1mA
Off State Leakage	Maximum 0.5mA
Output Signal Delay	OFF to ON: Maximum 0.5ms ON to OFF: Maximum 1ms
Indicator	1 Green Status
Output Current Rating	Maximum 0.5A
Surge Current	1.5A for 10ms, repeatable every 3 seconds
Fusing	Output are electronically protected
Output Type	Negative Logic type
Over Current Protection	1.8A (Shutdown Current)
General Specification	
Power Dissipation	Maximum 80mA @ 5.0Vdc
Isolation	I/O to Logic : Photo coupler Isolation
Wiring	I/O Cable Maximum 2.0mm ² (AWG#14)
Weight	70g
Module Size	12mm x 99mm x 70mm
Environment Condition	See "Environmental Specifications" in Appendix A.

ST-5111

Interface and Data

The following illustration shows the interface design for ST-5111.

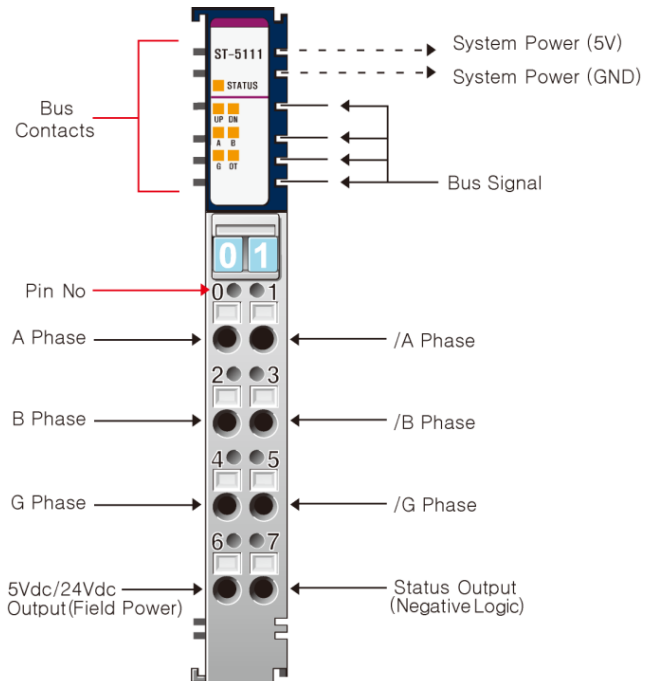
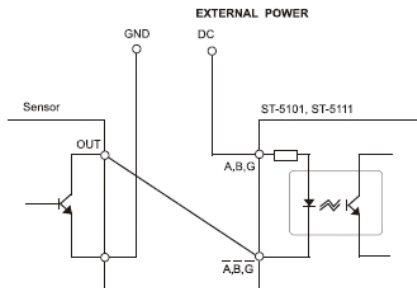
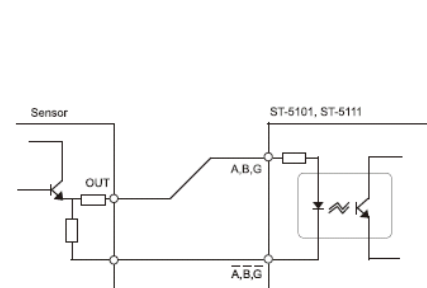

Figure 91: High Speed Counter Module: ST-5111

(1) Open Collector



(2) VOLTAGE OUTPUT



(3) LINE DRIVE

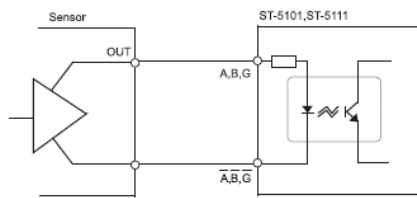

(4) SINK OUTPUT (STATUS)

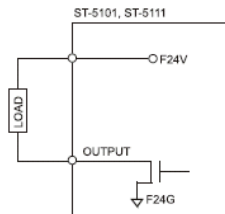

Specification

The following table describes the Input Specifications, Output Specifications, and the General Specifications for ST-5111.

Table 175: ST-5111: Input, Output and General Specifications

Items	Specification
Input Specification	
Input Voltage	24Vdc
Input Current	6.1mA @ 24Vdc
Input. On-State Current	Input Current \geq 2.9mA
Input Off-State Voltage	Input Voltage \geq 12Vdc
Output On-State Current	Input Current \leq 0.15mA
Output On-State Voltage	Input Voltage \leq 1.8Vdc
Maximum On-State Voltage	30V
Maximum Input Frequency	Maximum 1.5MHz
Output Specification	
Number of Outputs	7-8 States Output
Output Control	Output and be tied to any of 13 State
Output Supply Voltage Range	5 to 28.8Vdc (HSC Status Output)
On State Voltage Drop	Maximum 0.3Vdc
On State Current	Maximum 1mA
Off State Leakage	Maximum 0.5mA
Output Signal Delay	OFF to ON: Maximum 0.5ms ON to OFF: Maximum 1ms
Indicator	1 Green Status
Output Current Rating	Maximum 0.5A
Surge Current	1.5A for 10ms, repeatable every 3 seconds
Fusing	Output are electronically protected
Output Type	Negative Logic
Over Current Protection	1.8A (Shutdown Current)
General Specification	
Power Dissipation	Maximum 80mA @ 5.0Vdc
Isolation	I/O to Logic : Photo coupler Isolation
Wiring	I/O Cable Maximum 2.0mm ² (AWG#14)
Weight	70g
Module Size	12mm x 99mm x 70mm
Environment Condition	See "Environmental Specifications" in Appendix A.

The following table lists the pin numbers and description for ST-5101 and ST-5111.

Table 176: ST-5101 and ST-5111: Pin Description

Pin Number	Description	Pin Number	Description
0	A Pulse Input	1	/A Pulse Input or GND
2	B Pulse Input	3	/B Pulse Input or GND
4	G Pulse Input	5	/G Pulse Input or GND
6	F24V	7	Status Output

ST-5112

Interface and Data

The following snapshot details the interface design for ST-5112.

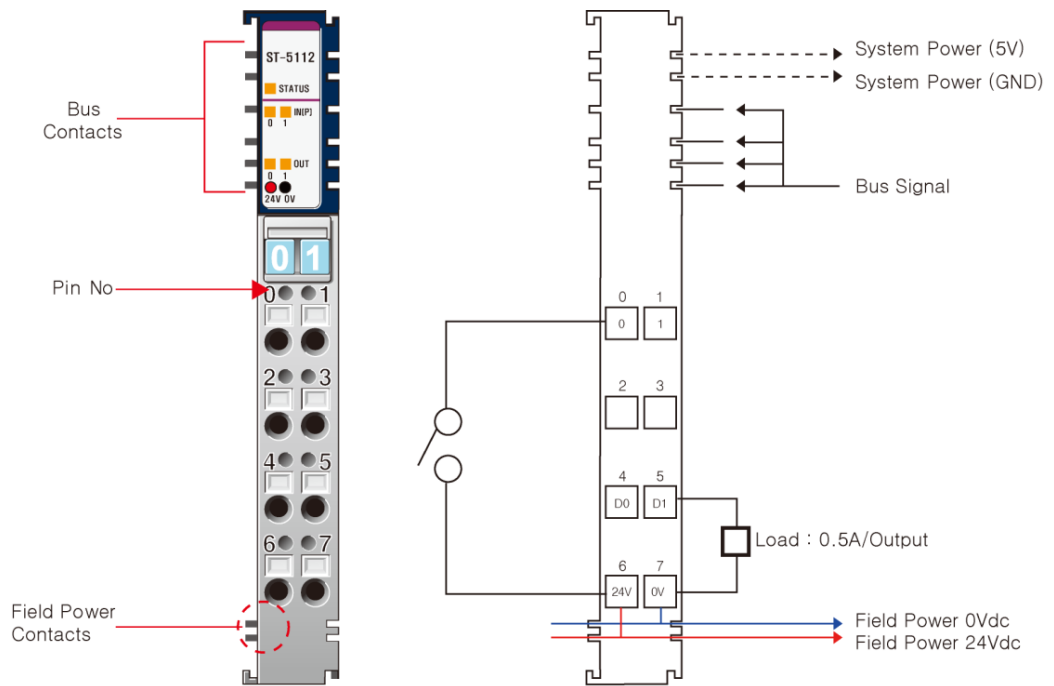

Figure 92: High Speed Counter Module: ST-5112

The following table lists the pin numbers and description for ST-5112.

Table 177: ST-5112: Pin Description

Pin Number	Description	Pin Number	Description
0	Counter Input Ch#0	1	Counter Input Ch#1
2	-	3	-
4	Digital Output Ch#0	5	Digital Output Ch#1
6	Field Power 24V	7	Field Power 0V, Common

Specification

The following table describes the Input Specifications, Output Specifications, and the General Specifications for ST-5112.

Table 178: ST-5112: Input, Output and General Specifications

Items	Specification
Input Specification	
Number of Channel	Maximum 2 Channel Counter, Positive Logic Input Type - 2 1-Input Mode : 2 Counters Available - 1 2-Input Mode : 1 Counters Available
Indicators	1 Green/Red RSTi Bus Status 2 Green Terminal Input LEDs 2 Green Terminal Output LEDs
Input Voltage	24Vdc
Input Current	6.1mA@24Vdc
Min. On-State Volt/Current	12Vdc/2.9mA
Maximum Off-State Volt/Current	7Vdc/1.0mA
Input Frequency	0~100KHz except Encoder 4x 0~50KHz, Encoder 4x
Counting Mode	1-Input Mode – Up, Down 2-Input Mode – Up/Inhibit, Up/Reset, Down/Inhibit, Down/Reset, Up/Down, Clock/Direction, Encoder 1x, Encoder 2x, Encoder 4x
Counter Size	32bit-wide/Channel
Common Type	2 Common
Output Specification	
Number of Outputs	2 Channel, Positive Logic Type
Output Voltage	24Vdc
Output Current	0.5A/Ch, 1A/All Channel, short protection
Diagnostic	Short Protection
General Specification	
Power Dissipation	Maximum 160mA @ 5.0Vdc
Isolation	I/O to Logic : Photo coupler Isolation I/O to Field Power : Non-Isolation
Field Power	Supply Voltage : 24Vdc nominal Voltage Range : 18~28.8Vdc Power Dissipation: Maximum 20mA @24Vdc
Wiring	I/O Cable Maximum 2.0mm ² (AWG#14)
Weight	70g
Module Size	12mm x 99mm x 70mm
Environment Condition	See "Environmental Specifications" in Appendix A.

ST-5114

Interface and Data

The following illustration shows the interface design for ST-5114.

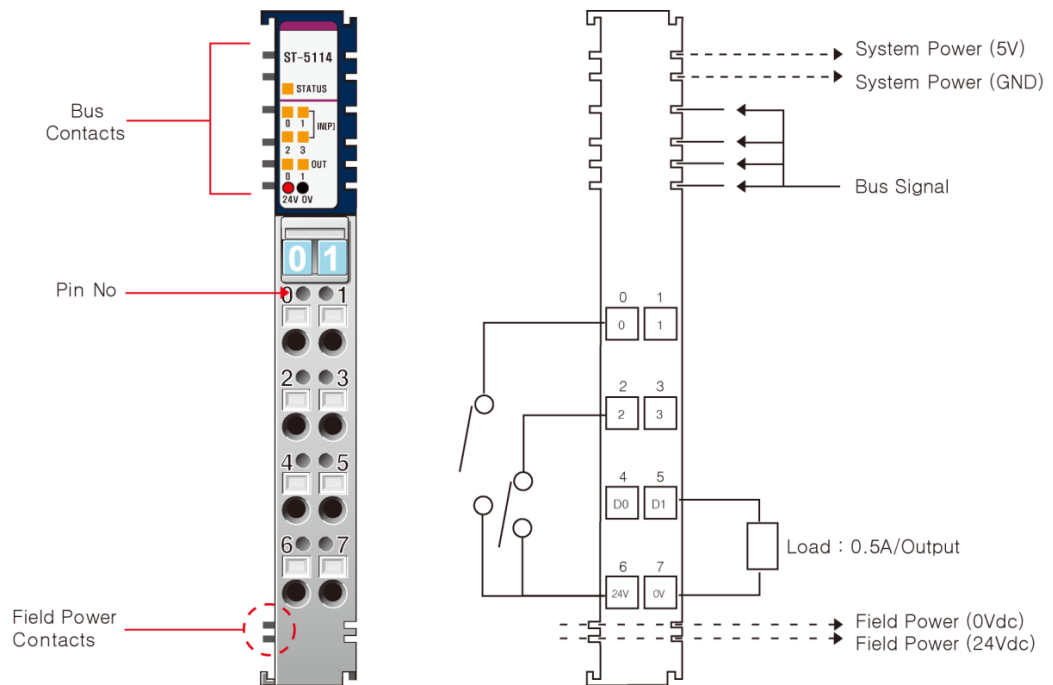

Figure 93: High Speed Counter Module: ST-5114

The following table lists the pin numbers and description for ST-5114.

Table 179: ST-5114: Pin Description

Pin Number	Description	Pin Number	Description
0	Counter Input Ch#0	1	Counter Input Ch#1
2	Counter Input Ch#2	3	Counter Input Ch#3
4	Digital Output Ch#0	5	Digital Output Ch#1
6	Field Power 24V	7	Field Power 0V, Common

Specification

The following table describes the Input Specifications, Output Specifications, and the General Specifications for ST-5114.

Table 180: ST-5114: Input, Output and General Specifications

Items	Specification
Input Specification	
Number of Channel	Maximum 4 Channel Counter, Positive Logic Input Type - 4 1-Input Mode : 4 Counters Available - 3 1-Input Mode & 1 2-Input Mode : 3 Counters Available - 2 2-Input Mode : 2 Counters Available
Indicators	1 Green/Red RSTi Bus Status 4 Green Terminal Input LEDs 2 Green Terminal Output LEDs
Input Voltage	24Vdc
Input Current	6.1mA@24Vdc
Min. On-State Volt/Current	12Vdc/2.9mA
Max. Off-State Volt/Current	7Vdc/1.0mA
Input Frequency	0~50KHz except Encoder 4x 0~25KHz, Encoder 4x
Counting Mode	1-Input Mode – Up, Down 2-Input Mode – Up/Inhibit, Up/Reset, Down/Inhibit, Down/Reset, Up/Down, Clock/Direction, Encoder 1x, Encoder 2x, Encoder 4x
Counter Size	32bit-wide/Channel
Common Type	2 Common
Output Specification	
Number of Outputs	2 Channel, Positive Logic Type
Output Voltage	24Vdc
Output Current	0.5A/Ch, 1A/All Channel, short protection
Diagnostic	Short Protection
General Specification	
Power Dissipation	Max. 160mA @ 5.0Vdc
Isolation	I/O to Logic : Photo coupler Isolation I/O to Field Power : Non-Isolation
Field Power	Supply Voltage : 24Vdc nominal Voltage Range : 18~28.8Vdc Power Dissipation: Max. 20mA @24Vdc
Wiring	I/O Cable Max. 2.0mm ² (AWG#14)
Weight	70g
Module Size	12mm x 99mm x 70mm
Environment Condition	See "Environmental Specifications" in Appendix A.

Dimensions of ST-5101, ST-5111, ST-5112, and ST-5114

The following illustration shows the dimensions for ST-5101, ST-5111, ST-5112, and ST-5114.

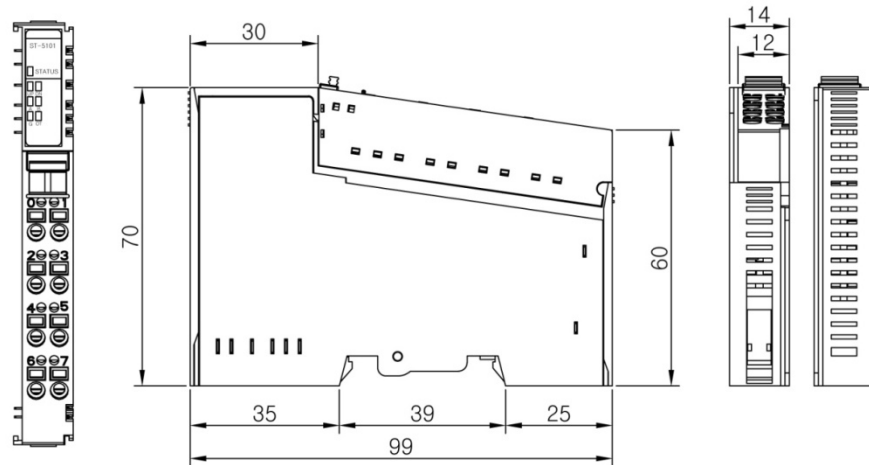

Figure 94: ST-5101, ST-5111, ST-5112, and ST-5114 Dimensions

Configuration and Operational Function

ST-5101 and ST-5111 - I/O Process Image Table

Input Image Data – 6 byte

Byte	Bit 7	Bit 6	Bit 5	Bit 4	Bit 3	Bit 2	Bit 1	Bit 0
0	Current Counter Value (Low) when IDS = 0 Current Counter Value (Low) when IDS = 1							
1	Current Counter Value (Middle) when IDS = 0 Current Counter Value (Middle) when IDS = 1							
2	Current Counter Value (High) when IDS = 0 Current Counter Value (High) when IDS = 1							
3	Always 0							
4	Status Low (compared flags)							
	0	0	SUF	SOF	SEQL(=)	SEQ(=)	SLT(<)	SGT(>)
5	Status High (same as LED flags)							
	0	0	SOT	SGIN	SBIN	SAIN	SDN	SUP

- Current Counter Value: The Current Counter value counts the value of incoming pulse. It can only read to binary number (0 to 16,777,215).
- Status Low (compared flags): The Status Low can only read:
 - SUF: Status Underflow (Latched)
 - SOF: Status Overflow (Latched)
 - SEQL(=): Status Current count value = Compare count value(Latched)
 - SEQ(=): Status Current count value = Compare count value(Unlatched)
 - SLT(<): Status Current count value < Compare count value(Unlatched)
 - SGT(>): Status Current count value > Compare count value(Unlatched)
- Status High (same as LED display): The Status High can only read:
 - SUP: Status Counter Up
 - SDN: Status Counter Down
 - SAIN: Status A Terminal Input
 - SBIN: Status B Terminal Input
 - SGIN: Status G Terminal Input
 - SOT: Status Output Terminal (same as OT)

Output Image Data – 2 byte

Byte	Bit 7	Bit 6	Bit 5	Bit 4	Bit 3	Bit 2	Bit 1	Bit 0
0	Status Output Terminal (OT) Control							
	Status Output Terminal Selection				Status Output Terminal Pulse Width			

	"0000" : Force Off "0001" : GT "0010" : LT "0011" : EQ "0101" : Overflow "0110" : Underflow "1001" : Count Up "1010" : Count Down "1011" : A Terminal Input "1100" : B Terminal Input "1101" : G Terminal Input "1110" : PWM Output "1111" : Force On Others : Force Off	"0000" : Bypass "0001" : 1msec "0010" : 5msec "0011" : 10msec "0100" : 20msec "0101" : 50msec "0110" : 100msec "0111" : 200msec "1000" : 500msec "1111" : Latched Others : Bypass								
1	Command or PWM Duty value (PWM Output Mode)									
	Command	7	6	5	4	3	2	1	0	
		HRST	CR	CP	CST	PU	PO	PE	IDS	
	PWM duty value	0~100dec (= 0~100%)								

- Status Output Terminal (OT) Control:** The Status Output Terminal Control can read and write to binary. Given below is an example of the output overflow flag in Status Register. When the Status flag detects a rising edge, Status Output is high with pulse width as set by the user for "Status output Pulse Width". Refer the table above which shows configuration of output image data for allowable range of pulse width and counter options.

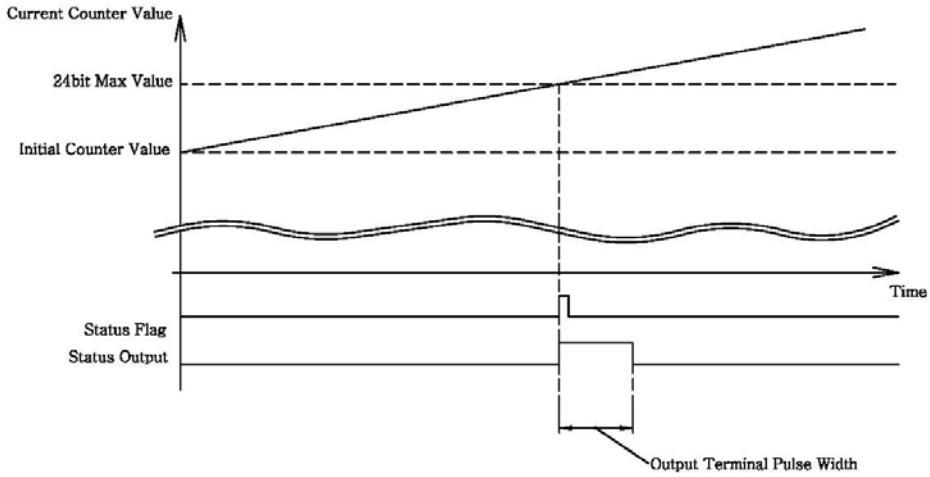

Figure 95: Output Overflow Flag in Status Register

- Command or PWM duty value (PWM Output Mode):** This 1 byte register can use Command or PWM duty value control. The Command control is used in general and if Gate Function/Counter Mode is set to PWM Output Mode, this register becomes a variable of PWM output duty value.

- The user can control the Command register. This register is used to read and write to binary number (8 bit).
 - IDS: Input data selection (0: Current counter value,1: Store counter value)
 - PE: Process Equal. When Current counter value = Compare counter value, then Current count value is set to Initial counter value.

Given below is an example that shows timing waveforms of Process Equal.

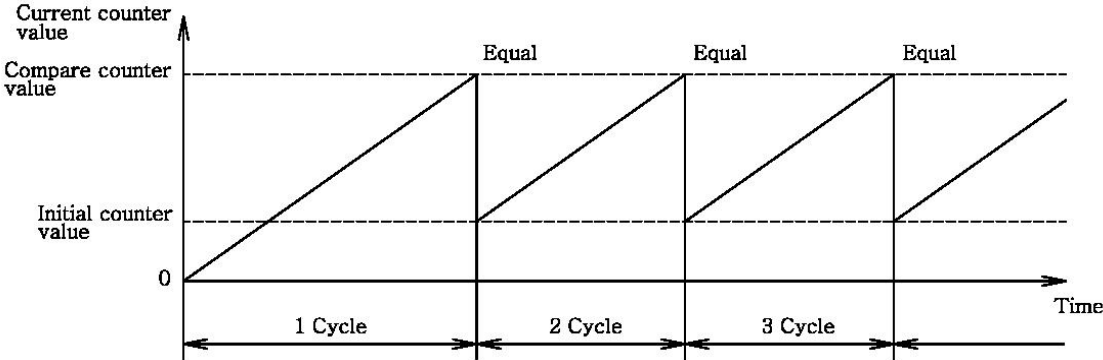

Figure 96: Timing Waveforms of Process Equal

- PO: Process Overflow. When Current counter value = Underflow, then the Current count value is set to Initial counter value.

Given below is an example that shows timing waveforms of Process Underflow

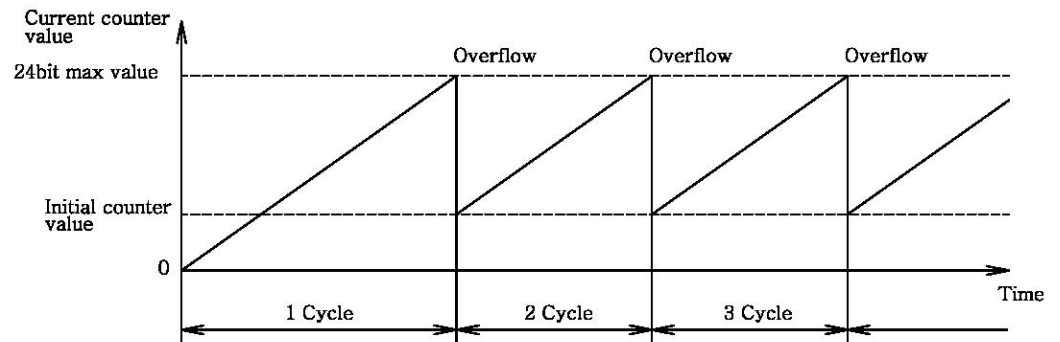

Figure 97: Timing Waveforms of Process Underflow

- PU: Process Underflow. When Current counter value = Overflow, then the Current count value is set to Initial counter value.

Given below is an example that shows timing waveforms of Process Overflow.

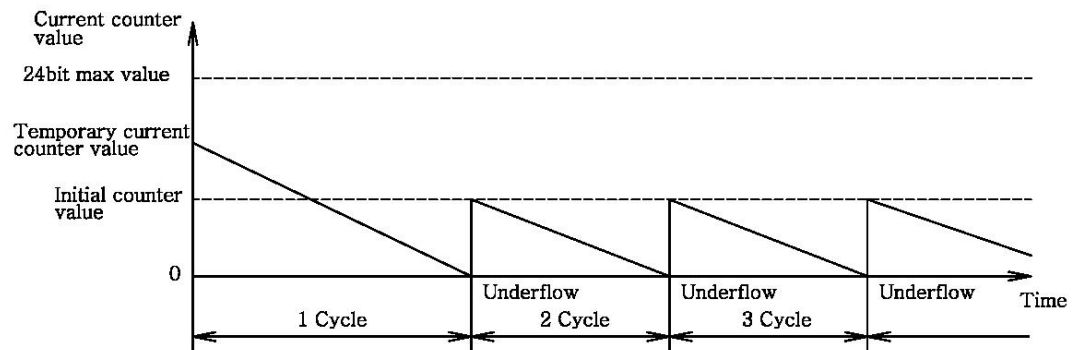

Figure 98: Timing Waveforms of Process Overflow

- CST: Clear Status (SOT,SUF,SOF,SEQL)
- CP: Counter Preset, Current counter value = Initial counter value
- CR: Counter Reset, Current counter value = 0
- HRST: Reset current counter value, stored counter value and Stats
- PWM duty value: When Counter Mode is set to PWM Output Mode, this register can use PWM Duty = 0 ~ 100 (= 0 ~ 100%). If the Value is greater than 100 then 100%.

Given below is a graphic representation of an error rate of duty (when Duty =50% and load =11kΩ)

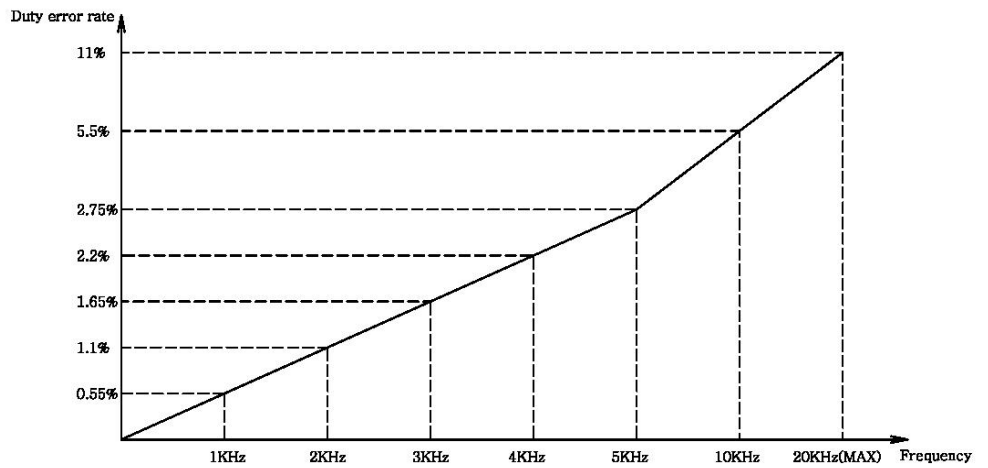

Figure 99: Error rate of Duty

■ PWM Mode in Gate Function/Counter Mode.

Given below is an example of PWM waveforms about PWM duty value, where T = Time (If Frequency = 10 KHz then T = 0.1ms)

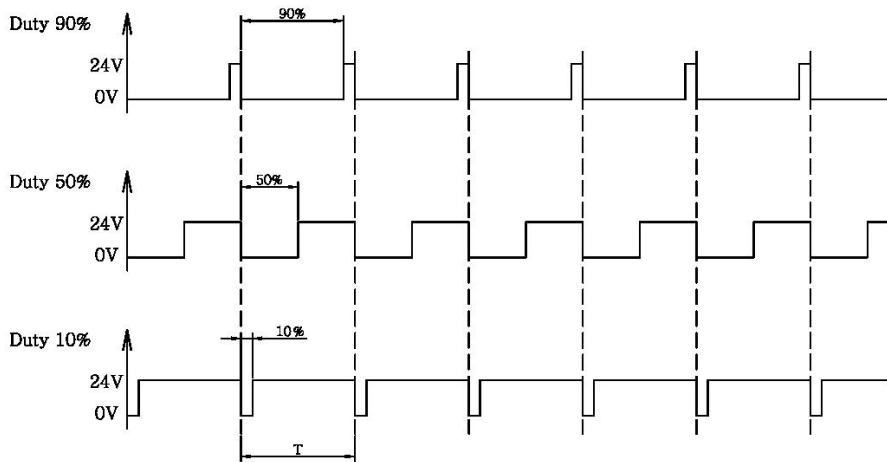

Figure 100: PWM Waveforms about PWM Duty Value

Configuration Parameter Table – 2 byte

Byte	Bit 7	Bit 6	Bit 5	Bit 4	Bit 3	Bit 2	Bit 1	Bit 0
0	Counter Mode/Gate Function							
	Gate Function "0000" : Gate Function Disabled "0001" : Store/Continue "0010" : Store/Wait/Resume "0011" : Store-Reset/Wait/Start "0100" : Store-Reset/Start Others : Gate Function Disabled				Count Mode "0000" : Counter Disabled "0001" : 1Pulse Mode "0010" : 2Pulse Mode "0011" : Encoder x1 "0100" : Encoder x2 "0101" : Encoder x4 "0110" : Period/Rate Mode "0111" : reserved "1000" : PWM Output Mode "1001" : reserved Others : Counter Disable			
1	Input Filter / Gate Sampling Time							
	Gate Sampling Time "0000" : (10/1)MHz (0.1usec) "0001" : (10/2)MHz (0.2usec) "0010" : (10/4)MHz (0.4usec) "0011" : (10/8)MHz (0.8usec) "0100" : (10/16)MHz (1.6usec) "0101" : (10/32)MHz (3.2usec) "0110" : (10/64)MHz (6.4usec) "0111" : (10/128)MHz (12.8usec) Others : (10/1)MHz (0.1usec)				Input Filter "0000" : Bypass(about 1.5MHz) "0001" : 1usec (500KHz±30%) "0010" : 5usec (100KHz±30%) "0011" : 10usec (50KHz±30%) "0100" : 50usec (10KHz±30%) "0101" : 100usec (5KHz±30%) "0110" : 500usec (1KHz±30%) "0111" : 1msec (500Hz±30%) "1000" : 5msec (100Hz±30%) "1001" : 10msec (50Hz±30%) Others : Bypass (about 1.5MHz)			

Note: Configuration Parameters can only be used for explicit messages. Please refer to Network Adaptor User Manual for more information on Explicit Message table.

- Gate Function/Counter Mode(Parameter Byte #0)
- The user can control the Command register. This register is used to read and write to binary number (8 bit).
 - ◦ Counter Mode
 - 1 Pulse Mode (A: Pulse, B: Direction): The 1 Pulse Mode reads incoming pulses and returns a binary number (0 to 16,777,215) to RSTi Bus. The 1 Pulse Mode accepts only one-phase inputs. The module determines the Phase B input status to up or down count. (B Phase = High: Down Counter, B Phase = Low: Up Counter).

Given below is an example of timing waveforms of 1 Pulse Method Pulse Mode.

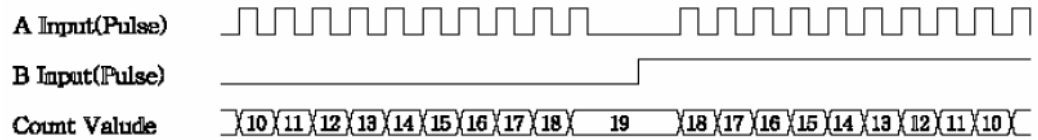

Figure 101: Timing Waveforms of 1 Pulse Method Pulse Mode

- 2 Pulse Mode (A: Up Pulse, B: Down Pulse): The 2 Pulse Mode reads incoming pulses and returns a binary (0 to 16,777,215) to RSTi Bus. The 2 Pulse Mode only accepts 2 Phase input. If A Phase reads incoming pulse and B Phase low, the time is up count state.

Given below is an example of timing waveforms of Pulse 2 Pulse Mode.

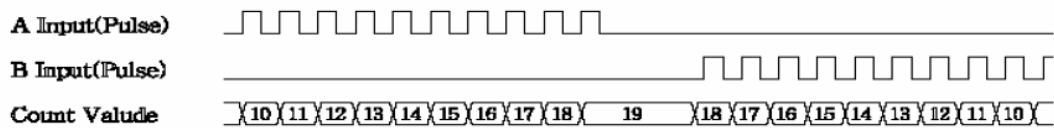

Figure 102: Timing Waveforms of 2 Pulse Mode

- Encoder x1 (A:Aph, B:Bph): The Encoder x1 reads incoming pulse and returns number (0 to 16,777,215) to the RSTi Bus. The Encoder x1 only accepts 2 Phase quadrature (90°) input. The mode senses the relationship between the 2 Phase, and counts up or down accordingly.

Given below is an example of timing waveforms of Encoder x1.

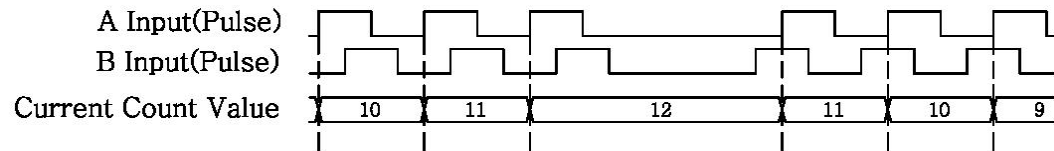

Figure 103: Timing Waveforms of Encoder x1

- Encoder x2 (A:Aph, B:Bph): The Encoder x2 reads incoming pulse and returns number (0 to 16,777,215) to the RSTi Bus. The Encoder x2 only accepts 2 Phase quadrature (90°) input. The mode senses the relationship between the 2 Phase, and counts up or down accordingly.

Given below is an example of timing waveforms of Encoder x2.

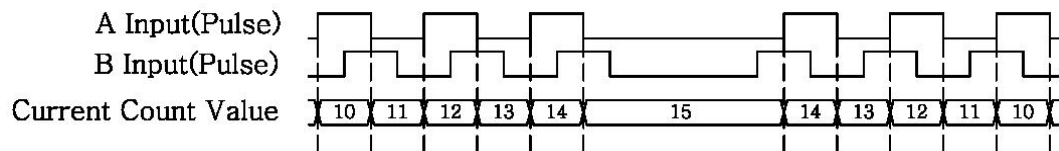

Figure 104: Timing Waveforms of Encoder x2

- Encoder x4 (A:Aph, B:Bph): The Encoder x4 reads incoming pulse and returns number (0 to 16,777,215) to the RSTi Bus. The Encoder x4 only accepts 2 Phase

quadrature (90°) input. The mode senses the relationship between the 2 Phase, and counts up or down accordingly.

Given below is an example of timing waveforms of Encoder x4.

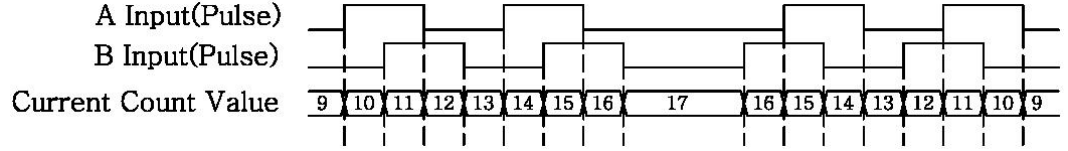

Figure 105: Timing Waveforms of Encoder x4

- Period/Rate Mode (Gate Function Disabled): The Period/Rate Mode will return total Current Count Value to the RSTi Bus, by gating an Internal Sampling Clock with an external signal. This mode determines the total number of input pulses by counting the number of internal sample clock ticks over a user-specified number of input signal pulses.

Given below is an example of timing waveforms of Period/Rate Mode.

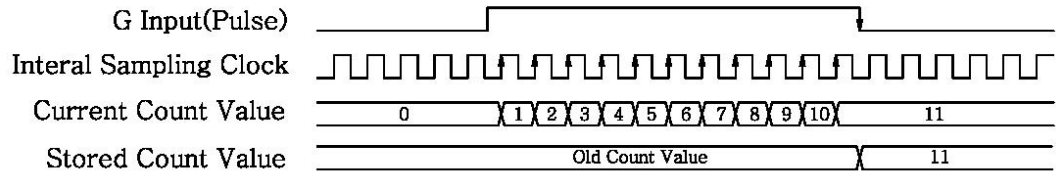

Figure 106: Timing Waveforms of Period/Rate Mode

- PWM (Pulse Width Modulation) Output Mode: The PWM Output Mode uses the Current counter value to generate a continuous rolling sequence of numbers. The configurations of PWM range value have a frequency (1 to 20 KHz) and duty cycle (0 to 100%). The PWM output can be used to direct the PWM signal to terminal output.

Given below is an example of timing waveforms of PWM Output Mode.

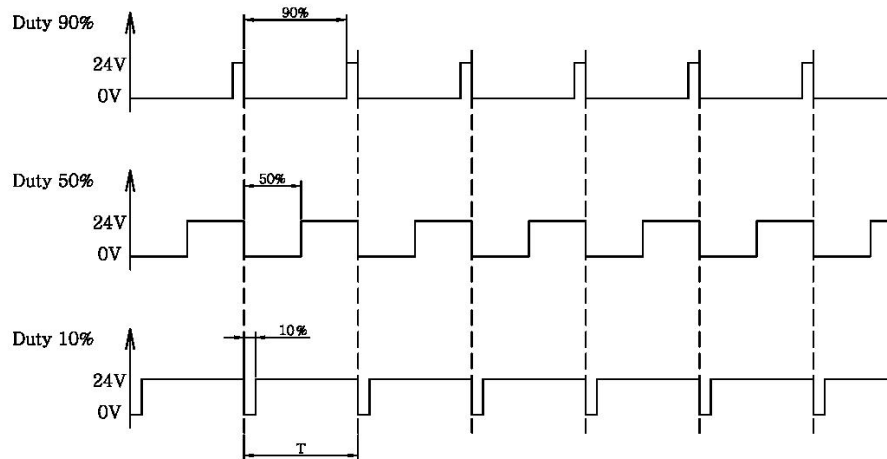

Figure 107: Timing Waveforms of PWM Output Mode

- ◦ Gate Function Mode: This Gate Function will operate in one of the five modes (Store/Continue, Store/Wait/Resume, Store-Reset/Wait/ and Store-Reset/Start). The Gate Function was unused to Period /Rate.
- Store/Continue: When G ph detects a rising edge, the Stored Count Value register will get counting value from Current Count Value register. Next Current Count Value will continue counting.

Given below is an example of timing waveforms of Store/Continue.

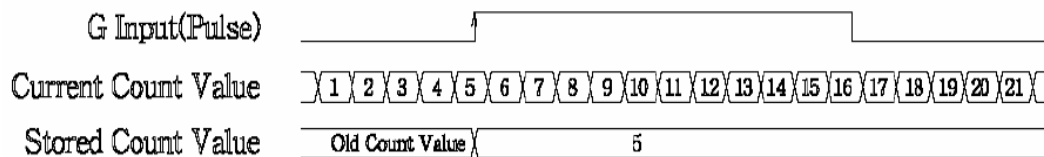

Figure 108: Timing Waveforms of Store/Continue

- Store/Wait/Resume: When G Ph are rising edge, the Stored Count Value register will get counting value from Current Count Value register and waits the Current Count Value until falling edge. Next G Ph will be filling edge and Current Count Value register resumes counting.

Given below is an example of timing waveforms of Store/Wait/Resume.

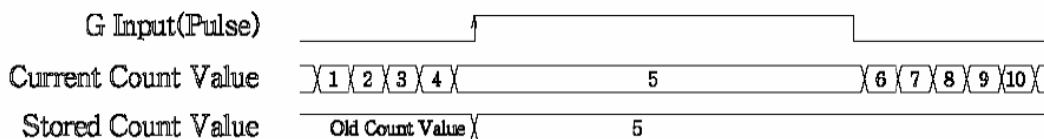

Figure 109: Timing Waveforms of Store/Wait/Resume

- Store-Reset/Wait/Start: When G Ph are rising edge, the Stored Count Value register will get counting value from Current Count Value register and Current Count Value register resets at the same time. The Current Count Value register waits until G Ph falling edge. Next Current Count Value register starts counting. Given below is an example of timing waveforms of Store-Reset/Wait/Start.

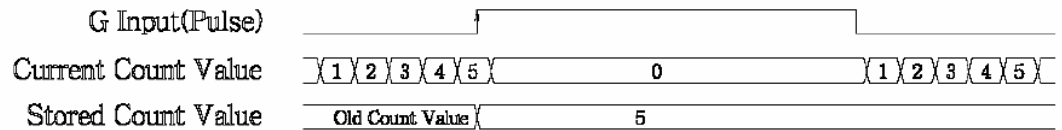

Figure 110: Timing Waveforms of Store-Reset/Wait/Start

- Store-Reset//Start: When G Ph are rising edge, the Stored Count Value register will get counting value by Current Count Value register and Current Count Value register resets at the same time and the register starts counting. Given below is an example of timing waveforms of Store-Reset//Start.

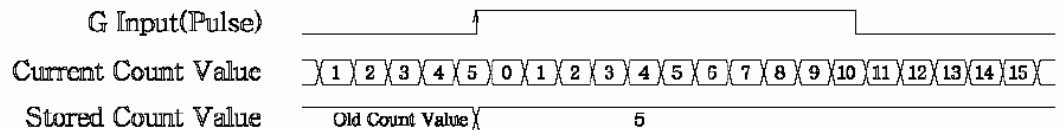

Figure 111: Timing Waveforms of Store-Reset/Start

- Gate Sampling Time/Input Filter (Parameter Byte #1): This Gate Sampling Time/Input Filter can read and write to binary. RSTi-HSC-5101 module has low path filter which can control by Input Filter (0 to 4bit) value. When Input Filter is 1usec sampling, the filtering principle is as shown below. The sampled the number of time can third more. Otherwise Input pulse will be erased. If Input Filter is set to 5usec ("0010"), passing frequency is 0 ~ 100Hz.

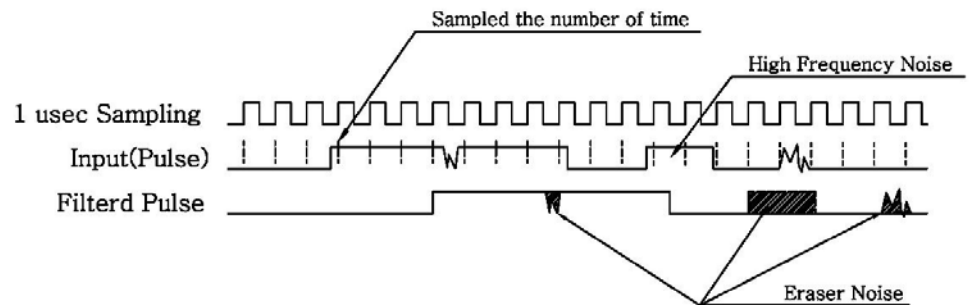

Figure 112: Timing Waveforms of Gate Sampling Time/Input Filer

When this register is set to Period/Rate mode, Internal Sampling Clock is used as frequency.

Memory Register Map

Byte Offset	Access	Description	Default Value
0	R	Current count value (Low byte) (Input Data Byte#0)	0x00
1	R	Current count value (Middle byte) (Input Data Byte#1)	0x00
2	R	Current count value (High byte) (Input Data Byte#2)	0x00
3	R	Always 0 (Input Data Byte#3)	0x00
4	R	Status Low (compared flags) (Input Data Byte#4)	0x00
5	R	Status High (same as LED display) (Input Data Byte#5)	0x00
6	R	Output Terminal (OT) Control (Output Data Byte#0)	0x00
7	R	SSR (Special Selection Register) (Output Data Byte#1)	0x00
8	R/W	Gate Function/Counter Mode (Parameter Byte#0)	0x00
9	R/W	Gate Sampling Time/Input Filter (Parameter Byte#1)	0x00
10	R/W	Don't care	0x00
11	R/W	Don't care	0x00
12	R	Stored count value (Low Byte) (Input Data Byte#0)	0x00
13	R	Stored count value (Middle Byte) (Input Data Byte#1)	0x00
14	R	Stored count value (High Byte) (Input Data Byte#2)	0x00
15	R	Always 0 (Input Data Byte#3)	0x00
16	R/W	Initial Counter Value (Low Byte) (Initial counter or PWM Frequency value)	0x00
17	R/W	Initial Counter Value (Middle Byte) (Initial counter or PWM Frequency value)	0x00
18	R/W	Initial Counter Value (High Byte) (Initial counter or PWM Frequency value)	0x00
19	R/W	Always 0	0x00
20	R/W	Compare count value (Low Byte)	0x00
21	R/W	Compare count value (Middle Byte)	0x00
22	R/W	Compare count value (High Byte)	0x00
23	R/W	Always 0	0x00

Note: Some Memory Registers can only be used for explicit message. Please refer Explicit Message table in Network Adaptor User Manual.

– • Stored counter value Register

This register can only return 24bit binary number (0 to 16,777,215).

This register used to Period/Rate and Gate Counter mode.

– • Initial Counter Value

This 4byte register can do use to Initial counter or PWM Frequency value control. The Initial counter value is used to general configuration the Current counter value and if Gate Function/Counter Mode set to PWM Output Mode, this register is a variable of PWM output frequency value.

– ◦ General configuration for initial current counter

RSTi HSC-5101 Module exist Initial counter value for starting of Current count value. Current count value begins starting from Initial counter value.

User can configure Initial counter value.

If user cannot configure Initial counter value, it is fixed to value (0x000000).

This Initial counter value used to PO, PU, and PE.

This Initial counter value can read and write to binary number (0 to 16,777,215).

– ◦ Setting PWM Frequency value

If Gate Function/Counter Mode is set to PWM Output Mode, this register is frequency value of PWM output

PWM Frequency = 1 ~ 20000 (=1Hz~20 KHz). If PWM Frequency value < 1 then off, if PWM Frequency value > 20000 then 20 KHz

Given below is an example of timing waveforms of PWM Output Mode.

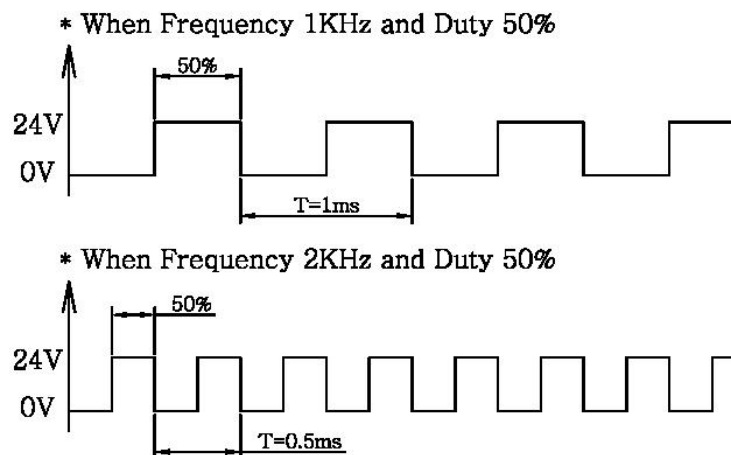

Figure 113: Timing Waveforms of PWM Output Mode

- Compare counter value: In RSTi Bus HSC-5101 Module exists, Compare counter value for compare with Current Count Value. Status does transformation by comparing value of Current Count Value and Compare Value Set Register. Compare counter value used to compare Current Counter value for Status. If user cannot configure Compare counter value, it is fixed to a value (0x000000). This register uses PO, PU, and PE and Status output. This register can read and write to binary number (0 to 16,777,215).

ST-5112 - I/O Process Image Table

Input Image Data – 8 byte

Byte	Bit 7	Bit 6	Bit 5	Bit 4	Bit 3	Bit 2	Bit 1	Bit 0
0	Counter Value Ch#0 LL							
1	Counter Value Ch#0 LH							
2	Counter Value Ch#0 HL							
3	Counter Value Ch#0 HH							
4	Counter Value Ch#1 LL							
5	Counter Value Ch#1 LH							
6	Counter Value Ch#1 HL							
7	Counter Value Ch#1 HH							

- Counter Value Ch#0~1 is a 32bit-wide data.

Output Image Data – 2 byte

Byte	Bit 7	Bit 6	Bit 5	Bit 4	Bit 3	Bit 2	Bit 1	Bit 0
0	CR0	CS0	DO1	DO0	CountMode0 (refer Count Mode Table)			
1	CR1	CS1	----	----	CountMode1 (refer Count Mode Table)			

- CR0,1 : Counter Reset for Ch#0,1
- CS0,1 : Counter Stop (Inhibit Input) for Ch#0,1
- DO0,1 : Digital Output for Output Ch#0,1
- CountMode0,1 Count Mode for : Ch#0,1
- Count Mode Table

1/2 Input	Value	Count Mode	Description
1-Input Mode	B'0000 (0x0)	Up Clock	Counter Input Ch#0~1 act as Up Clock to Ch#0~1
	B'0001 (0x1)	Down Clock	Counter Input Ch#0~1 act as Down Clock to Ch#0~1
	B'0010 (0x2)	-----	-----
	B'0011 (0x3)	-----	-----
2-Input Mode	B'0100 (0x4)	Up Clock & Inhibit	If CountMode0=0x4, CountMode1 is not used. <ul style="list-style-type: none"> – Counter Input Ch#0 acts as Up Clock Input to Ch#0 – Counter Input Ch#1 acts as Inhibit Input to Ch#0
	B'0101 (0x5)	Up Clock & Reset	If CountMode0=0x5, CountMode1 is not used. <ul style="list-style-type: none"> – Counter Input Ch#0 acts as Up Clock Input to Ch#0 – Counter Input Ch#1 acts as Reset Input to Ch#0

	B'0110 (0x6)	Down Clock & Inhibit	If CountMode0=0x6, CountMode1 is not used. <ul style="list-style-type: none"> – Counter Input Ch#0 acts as Down Clock Input to Ch#0 – Counter Input Ch#1 acts as Inhibit Input to Ch#0
	B'0111 (0x7)	Down Clock & Reset	If CountMode0=0x7, CountMode1 is not used. <ul style="list-style-type: none"> – Counter Input Ch#0 acts as Down Clock Input to Ch#0 – Counter Input Ch#1 acts as Reset Input to Ch#0
	B'1000 (0x8)	Up Clock & Down Clock	If CountMode0=0x8, CountMode1 is not used. <ul style="list-style-type: none"> – Counter Input Ch#0 acts as Up Clock Input to Ch#0 – Counter Input Ch#1 acts as Down Clock Input to Ch#0
	B'1001 (0x9)	Clock & Direction	If CountMode0=0x9, CountMode1 is not used. <ul style="list-style-type: none"> – Counter Input Ch#0 acts as Clock Input to Ch#0 – Counter Input Ch#1 acts as Direction Input to Ch#0
	B'1010 (0xA)	Encoder 1x	If CountMode0=0xA, CountMode1 is not used. <ul style="list-style-type: none"> – Counter Input Ch#0 acts as A phase Input to Ch#0 – Counter Input Ch#1 acts as B phase Input to Ch#0
	B'1011 (0xB)	Encoder 2x	If CountMode0=0xB, CountMode1 is not used. <ul style="list-style-type: none"> – Counter Input Ch#0 acts as A phase Input to Ch#0 – Counter Input Ch#1 acts as B phase Input to Ch#0
	B'1100 (0xC)	Encoder 4x	If CountMode0=0xC, CountMode1 is not used. <ul style="list-style-type: none"> – Counter Input Ch#0 acts as A phase Input to Ch#0 – Counter Input Ch#1 acts as B phase Input to Ch#0
	B'1101 (0xD)	-----	-----
	B'1110 (0xE)	-----	-----
	B'1111 (0xF)	-----	-----

– If CountMode0 is 2-Input Mode, CountMode1 and Counter Input Ch#0 do not affect Counter Value Ch#1.

- Do not assign 2-Input Mode to CountMode1.
- Refer to COUNT MODE for details.

Configuration Parameter Data – 4byte

Byte	Bit 7	Bit 6	Bit 5	Bit 4	Bit 3	Bit 2	Bit 1	Bit 0
0	Reserved							
1	Reserved							
2	Reserved							
3	Reserved							

ST-5114 - I/O Process Image Table

Input Image Data – 16 byte

Byte	Bit 7	Bit 6	Bit 5	Bit 4	Bit 3	Bit 2	Bit 1	Bit 0
0	Counter Value Ch#0 LL							
1	Counter Value Ch#0 LH							
2	Counter Value Ch#0 HL							
3	Counter Value Ch#0 HH							
4	Counter Value Ch#1 LL							
5	Counter Value Ch#1 LH							
6	Counter Value Ch#1 HL							
7	Counter Value Ch#1 HH							
8	Counter Value Ch#2 LL							
9	Counter Value Ch#2 LH							
10	Counter Value Ch#2 HL							
11	Counter Value Ch#2 HH							
12	Counter Value Ch#3 LL							
13	Counter Value Ch#3 LH							
14	Counter Value Ch#3 HL							
15	Counter Value Ch#3 HH							

- Counter Value Ch#0~3 is a 32bit-wide data.

Output Image Data – 4 byte

Byte	Bit 7	Bit 6	Bit 5	Bit 4	Bit 3	Bit 2	Bit 1	Bit 0
0	CR0	CS0	DO1	DO0	CountMode0 (refer Count Mode Table)			
1	CR1	CS1	----	----	CountMode1 (refer Count Mode Table)			
2	CR2	CS2	----	----	CountMode2 (refer Count Mode Table)			
3	CR3	CS3	----	----	CountMode3 (refer Count Mode Table)			

- CR0,1,2,3 : Counter Reset for Ch#0,1,2,3
- CS0,1,2,3 : Counter Stop (Inhibit Input) for Ch#0,1,2,3
- DO0,1 : Digital Output for Output Ch#0,1
- CountMode0,1,2,3 Count Mode for : Ch#0,1,2,3
- Count Mode Table

<i>1/2 Input</i>	<i>Value</i>	<i>Count Mode</i>	<i>Description</i>
1-Input Mode	B'0000 (0x0)	Up Clock	Counter Input Ch#0~3 act as Up Clock to Ch#0~3
	B'0001 (0x1)	Down Clock	Counter Input Ch#0~3 act as Down Clock to Ch#0~3
	B'0010 (0x2)	-----	-----
	B'0011 (0x3)	-----	-----
2-Input Mode	B'0100 (0x4)	Up Clock & Inhibit	<p>If CountMode0=0x4, CountMode1 is not used.</p> <ul style="list-style-type: none"> – Counter Input Ch#0 acts as Up Clock Input to Ch#0 – Counter Input Ch#1 acts as Inhibit Input to Ch#0 <p>If CountMode2=0x4, CountMode3 is not used</p> <ul style="list-style-type: none"> – Counter Input Ch#2 acts as Up Clock Input to Ch#2 – Counter Input Ch#3 acts as Inhibit Input to Ch#2
	B'0101 (0x5)	Up Clock & Reset	<p>If CountMode0=0x5, CountMode1 is not used.</p> <ul style="list-style-type: none"> – Counter Input Ch#0 acts as Up Clock Input to Ch#0 – Counter Input Ch#1 acts as Reset Input to Ch#0 <p>If CountMode2=0x5, CountMode3 is not used.</p> <ul style="list-style-type: none"> – Counter Input Ch#2 acts as Up Clock Input to Ch#2 – Counter Input Ch#3 acts as Reset Input to Ch#2
	B'0110 (0x6)	Down Clock & Inhibit	<p>If CountMode0=0x6, CountMode1 is not used.</p> <ul style="list-style-type: none"> – Counter Input Ch#0 acts as Down Clock Input to Ch#0 – Counter Input Ch#1 acts as Inhibit Input to Ch#0 <p>If CountMode2=0x6, CountMode1 is not used.</p> <ul style="list-style-type: none"> – Counter Input Ch#2 acts as Down Clock Input to Ch#2 – Counter Input Ch#3 acts as Inhibit Input to Ch#2
	B'0111 (0x7)	Down Clock & Reset	<p>If CountMode0=0x7, CountMode1 is not used.</p> <ul style="list-style-type: none"> – Counter Input Ch#0 acts as Down Clock Input

			<p>to Ch#0</p> <ul style="list-style-type: none"> – Counter Input Ch#1 acts as Reset Input to Ch#0 <p>If CountMode2=0x7, CountMode3 is not used.</p> <ul style="list-style-type: none"> – Counter Input Ch#2 acts as Down Clock Input to Ch#2 – Counter Input Ch#3 acts as Reset Input to Ch#2
B'1000 (0x8)	Up Clock & Down Clock		<p>If CountMode0=0x8, CountMode1 is not used.</p> <ul style="list-style-type: none"> – Counter Input Ch#0 acts as Up Clock Input to Ch#0 – Counter Input Ch#1 acts as Down Clock Input to Ch#0 <p>If CountMode2=0x8, CountMode3 is not used.</p> <ul style="list-style-type: none"> – Counter Input Ch#2 acts as Up Clock Input to Ch#2 – Counter Input Ch#3 acts as Down Clock Input to Ch#2
B'1001 (0x9)	Clock & Direction		<p>If CountMode0=0x9, CountMode1 is not used.</p> <ul style="list-style-type: none"> – Counter Input Ch#0 acts as Clock Input to Ch#0 – Counter Input Ch#1 acts as Direction Input to Ch#0 <p>If CountMode2=0x9, CountMode3 is not used.</p> <ul style="list-style-type: none"> – Counter Input Ch#2 acts as Clock Input to Ch#2 – Counter Input Ch#3 acts as Direction Input to Ch#2
B'1010 (0xA)	Encoder 1x		<p>If CountMode0=0xA, CountMode1 is not used.</p> <ul style="list-style-type: none"> – Counter Input Ch#0 acts as A phase Input to Ch#0 – Counter Input Ch#1 acts as B phase Input to Ch#0 <p>If CountMode2=0xA, CountMode3 is not used.</p> <ul style="list-style-type: none"> – Counter Input Ch#2 acts as A phase Input to Ch#2 – Counter Input Ch#3 acts as B phase Input to Ch#2
B'1011 (0xB)	Encoder 2x		<p>If CountMode0=0xB, CountMode1 is not used.</p> <ul style="list-style-type: none"> – Counter Input Ch#0 acts as A phase Input to Ch#0 – Counter Input Ch#1 acts as B phase Input to

			<p>Ch#0</p> <p>If CountMode2=0xB, CountMode3 is not used.</p> <ul style="list-style-type: none"> - Counter Input Ch#2 acts as A phase Input to Ch#2 - Counter Input Ch#3 acts as B phase Input to Ch#2
B'1100 (0xC)	Encoder 4x		<p>If CountMode0=0xC, CountMode1 is not used.</p> <ul style="list-style-type: none"> - Counter Input Ch#0 acts as A phase Input to Ch#0 - Counter Input Ch#1 acts as B phase Input to Ch#0 <p>If CountMode2=0xC, CountMode3 is not used.</p> <ul style="list-style-type: none"> - Counter Input Ch#2 acts as A phase Input to Ch#2 - Counter Input Ch#3 acts as B phase Input to Ch#2
B'1101 (0xD)	-----	-----	-----
B'1110 (0xE)	-----	-----	-----
B'1111 (0xF)	-----	-----	-----

- If CountMode0 is 2-Input Mode, CountMode1 and Counter Input Ch#0 do not affect Counter Value Ch#1.
- If CountMode2 is 2-Input Mode, CountMode3 and Counter Input Ch#3 do not affect Counter Value Ch#3.
- Do not assign 2-Input Mode to CountMode1,3

Configuration Parameter Data – 4 byte

Byte	Bit 7	Bit 6	Bit 5	Bit 4	Bit 3	Bit 2	Bit 1	Bit 0
0	Reserved							
1	Reserved							
2	Reserved							
3	Reserved							

Count Mode

Up Clock (0x0)

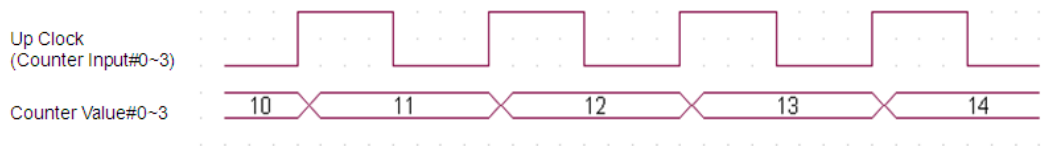

Down Clock (0x1)

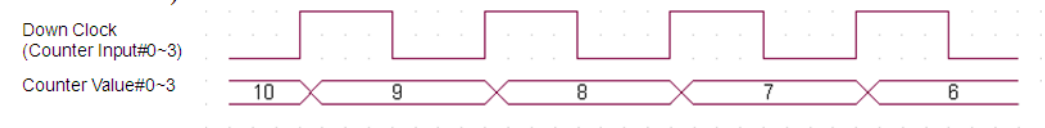

Up Clock & Inhibit (0x4)

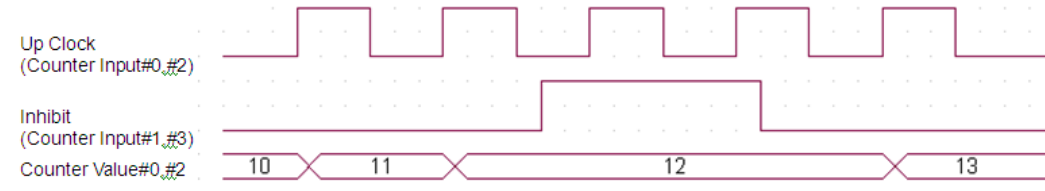

Up Clock & Reset (0x5)

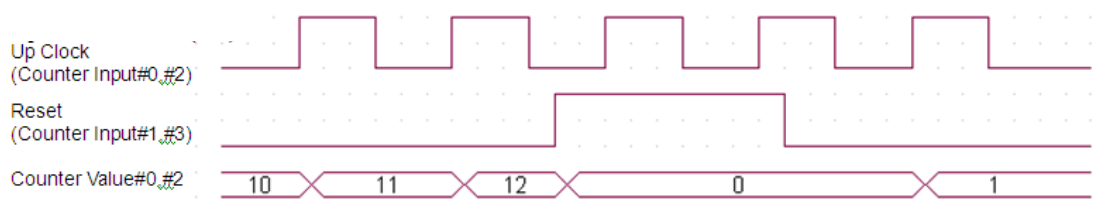

Down Clock & Inhibit (0x6)

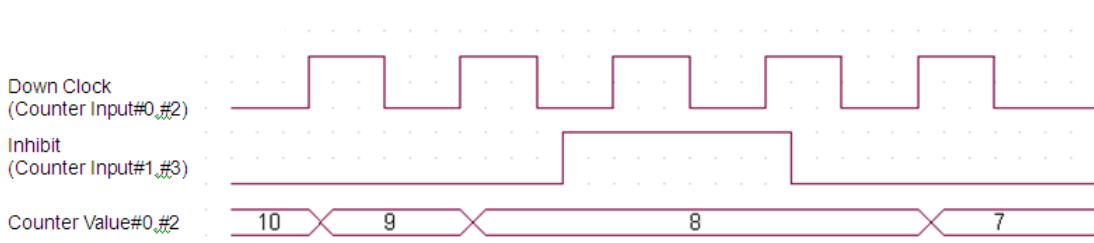

Down Clock & Reset (0x7)

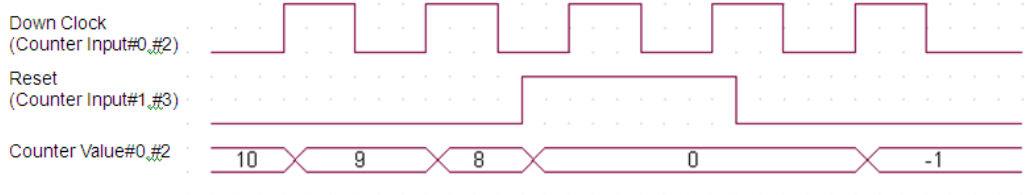

Up Clock & Down Clock (0x8)

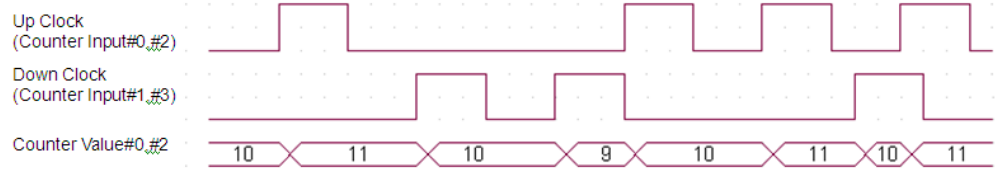

Clock & Direction (0x9)

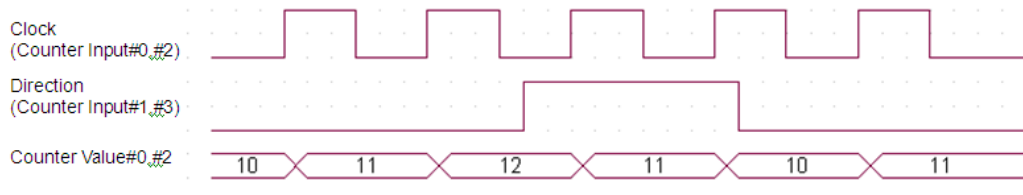

Encoder 1x (0xA)

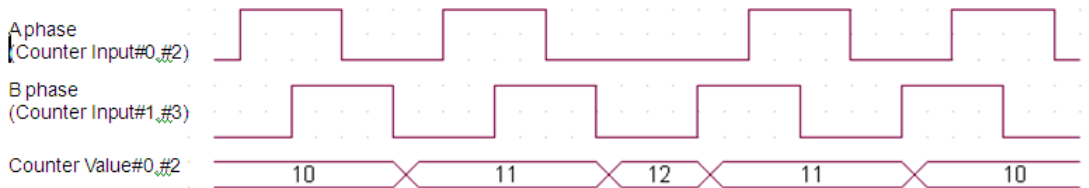

Encoder 2x (0xB)

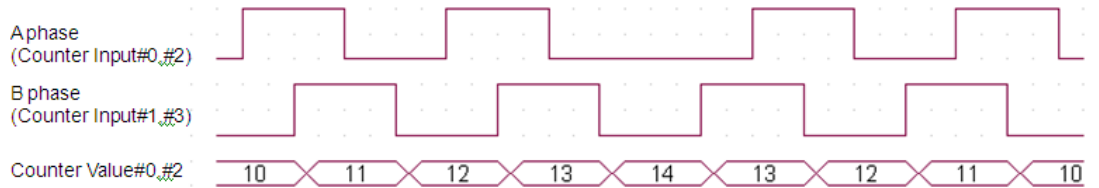

Encoder 4x (0xC)

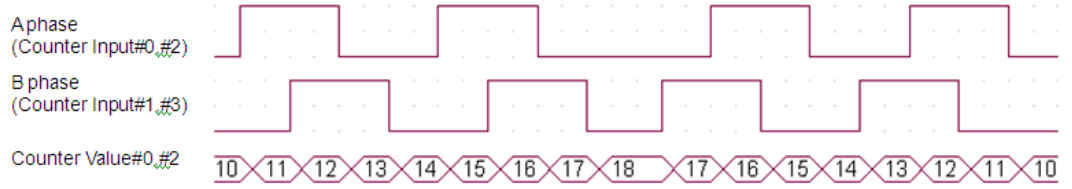

Serial Module

ST-5211

Interface and Data

The following illustration shows the interface design for ST-5211.

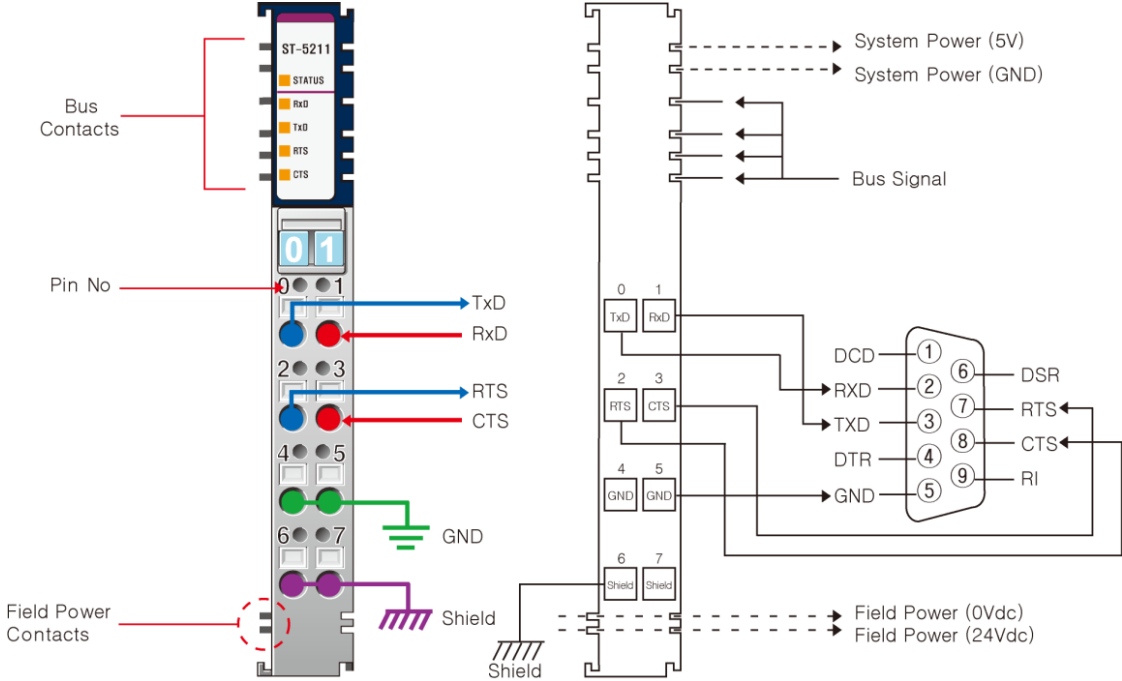

Figure 114: Serial Module: ST-5211

The following table lists the pin numbers and description for ST-5211.

Table 181: ST-5211: Pin Description

Pin Number	Description	Pin Number	Description
0	TxD	1	RxD
2	RTS	3	CTS
4	GND	5	GND
6	SHIELD	7	SHIELD

The following table describes the LED color and status for ST-5211.

Table 182: ST-5211: LED Color and Status

LED Name	Color	Status
RxD	Green	Received Data
TxD	Green	Transmit Data
RTS	Green	Request-to-send
CTS	Green	Clear-to-send

Specification

The following table describes the Interface Specifications and the General Specifications for ST-5211.

Table 183: ST-5211: Interface and General Specifications

<i>Items</i>	<i>ST-5211</i>
Interface Specification	
Transfer Channels	TxD, RxD, Full duplex
Transfer Rate	300~115300
Data Bit	7bit, 8bit, 9bit
Parity Bit	None, Odd, Even
Stop Bit	1bit, 2bit
Flow Control	RTS,CTS
Bit Distortion	<1.6%
Connection	Spring force of RTB
Cable Length	Max. 15m
Low Signal Voltage	-18V ~ -3V
High Signal Voltage	+18V ~ +3V
Isolation	Isolation Voltage: 1,000Vrms/Vac
RxD Buffer	1024Byte
TxD Buffer	256Byte
Line Impedance	--
Input Image Size	6 Byte
Output Image Size	6 Byte
General Specification	
Power Dissipation (System Power)	95mA max @ 5.0Vdc
Environment Condition	See "Environmental Specifications" in Appendix A.
Module Size	12x67x95 (WxHxL)

Dimension

The following illustration shows the dimension for ST-5211.

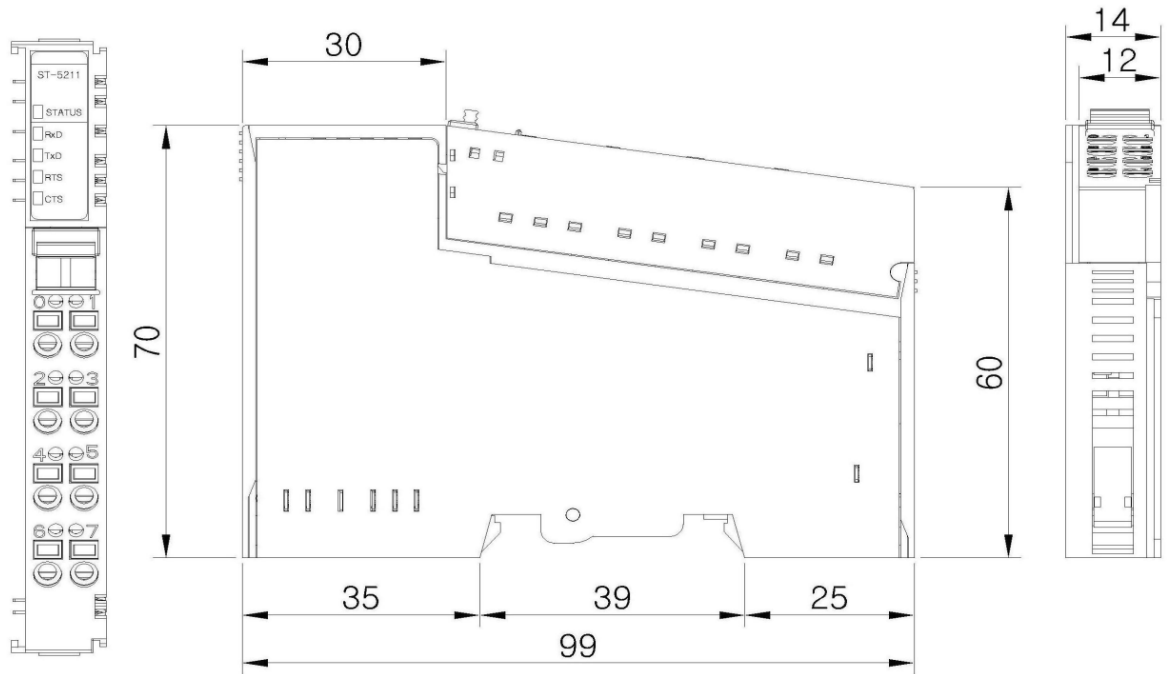

Figure 115: ST-5211 Dimension

ST-5212

Interface and Data

The following illustration shows the interface design for ST-5212.

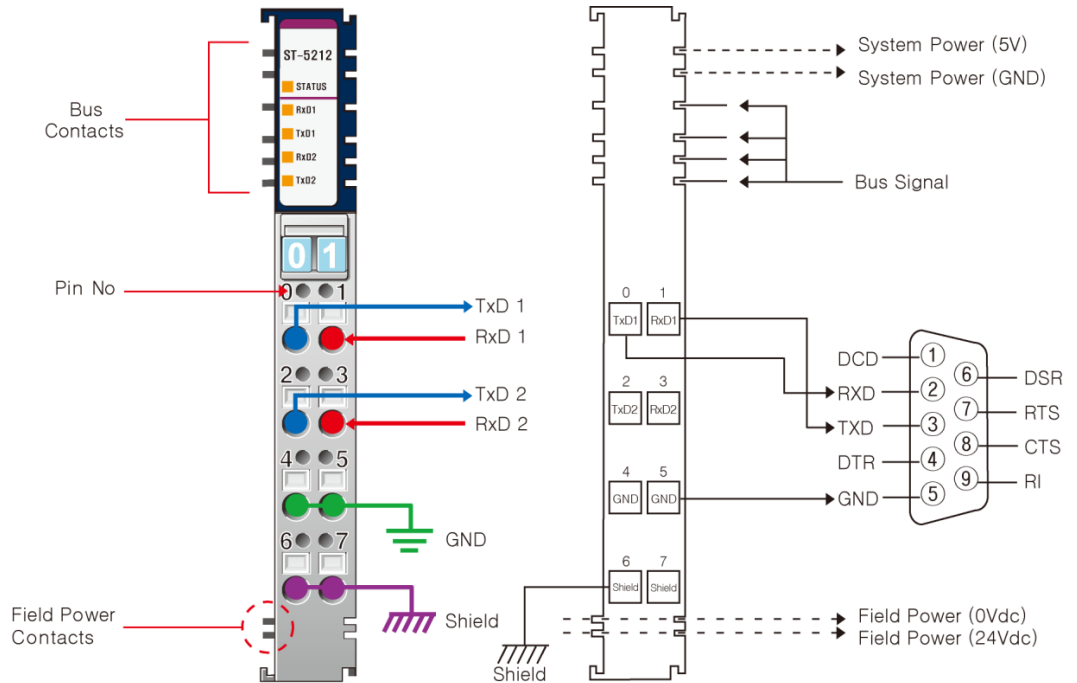

Figure 116: Serial Module: ST-5212

The following table lists the pin numbers and description for ST-5212.

Table 184: ST-5212: Pin Description

Pin Number	Description	Pin Number	Description
0	TxD channel #0	1	RxD channel #0
2	TxD channel #1	3	RxD channel #1
4	GND	5	GND
6	SHIELD	7	SHIELD

The following table describes the LED color and status for ST-5212.

Table 185: ST-5212: LED Color and Status

LED Name	Color	Status
RxD1	Green	Received Data #0
TxD1	Green	Transmit Data #0
RxD2	Green	Received Data #1
TxD2	Green	Transmit Data #1

Specification

The following table describes the Interface Specifications and the General Specifications for ST-5212.

Table 186: ST-5212: Interface and General Specifications

<i>Items</i>	<i>ST-5212</i>
Interface Specification	
Transfer Channels	TxD, RxD, Full duplex
Transfer Rate	300~115300
Data Bit	7bit, 8bit, 9bit
Parity Bit	None, Odd, Even
Stop Bit	1bit, 2bit
Flow Control	--
Bit Distortion	<1.6%
Connection	Spring force of RTB
Cable Length	Max. 15m
Low Signal Voltage	-18V ~ -3V
High Signal Voltage	+18V ~ +3V
Isolation	Isolation Voltage: 1,000Vrms/Vac
RxD Buffer	1024Byte
TxD Buffer	256Byte
Line Impedance	--
Input Image Size	12 Byte
Output Image Size	12 Byte
General Specification	
Power Dissipation (System Power)	110mA max @ 5.0 Vdc
Environment Condition	See "Environmental Specifications" in Appendix A.
Module Size	12x67x95 (WxHxL)

Dimension

The following illustration shows the dimension for ST-5212.

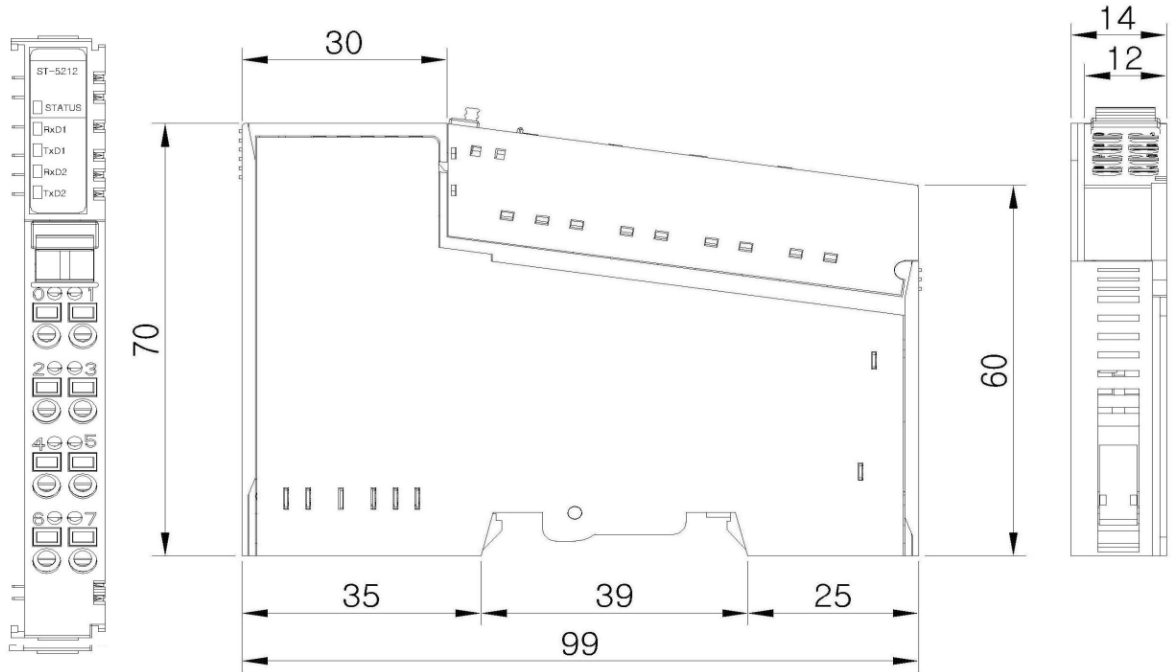

Figure 117: ST-5212 Dimension

ST-5221

Interface and Data

The following illustration shows the interface design for ST-5221.

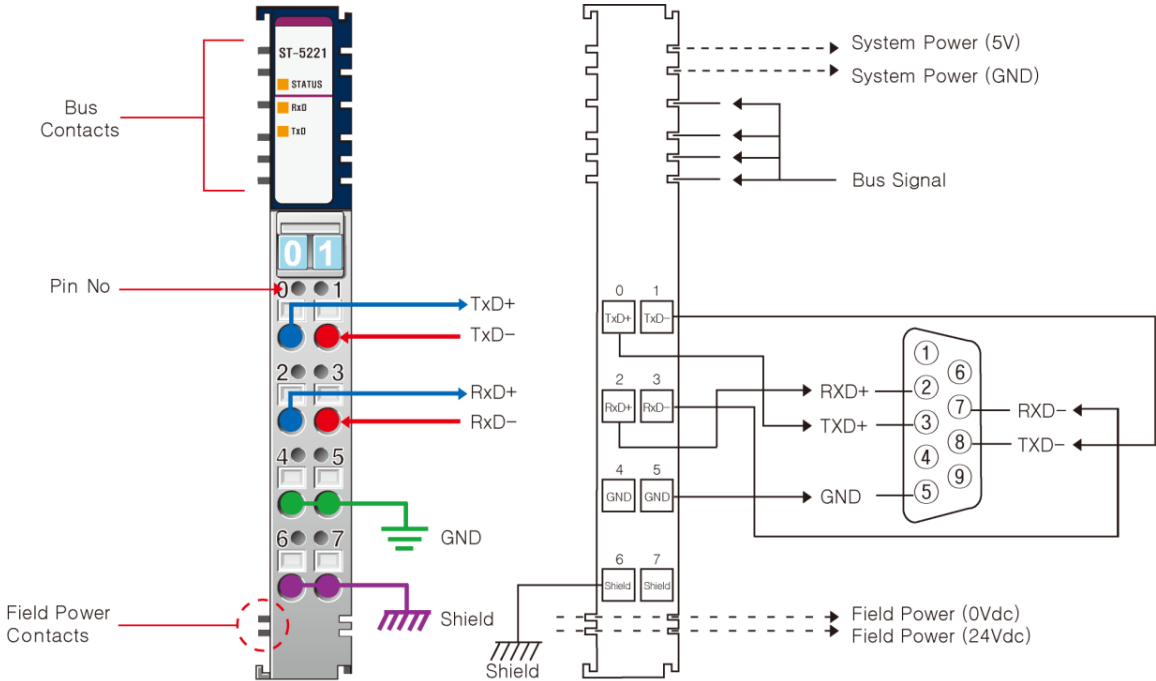

Figure 118: Serial Module: ST-5221

The following table lists the pin numbers and description for ST-5221.

Table 187: ST-5221: Pin Description

Pin Number	Description	Pin Number	Description
0	TxD +	1	TxD -
2	RxD +	3	RxD -
4	GND	5	GND
6	SHIELD	7	SHIELD

The following table describes the LED color and status for ST-5221.

Table 188: ST-5221: LED Color and Status

LED Name	Color	Status
RxD	Green	Received Data
TxD	Green	Transmit Data

Specification

The following table describes the Interface Specifications and the General Specifications for ST-5221.

Table 189: ST-5221: Interface and General Specifications

<i>Items</i>	<i>ST-5221</i>
Interface Specification	
Transfer Channels	TxD, RxD, Full duplex
Transfer Rate	300~115300
Data Bit	7bit, 8bit, 9bit
Parity Bit	None, Odd, Even
Stop Bit	1bit, 2bit
Flow Control	--
Bit Distortion	<1.6%
Connection	Spring force of RTB
Cable Length	1km twisted pair
Low Signal Voltage	--
High Signal Voltage	--
Isolation	Isolation Voltage: 1,000Vrms/Vac
RxD Buffer	1024Byte
TxD Buffer	256Byte
Line Impedance	120Ω
Input Image Size	6 Byte
Output Image Size	6 Byte
General Specification	
Power Dissipation (System Power)	155mA max @ 5.0 Vdc
Environment Condition	See "Environmental Specifications" in Appendix A.
Module Size	12x67x95 (WxHxL)

Dimension

The following illustration shows the dimension for ST-5221.

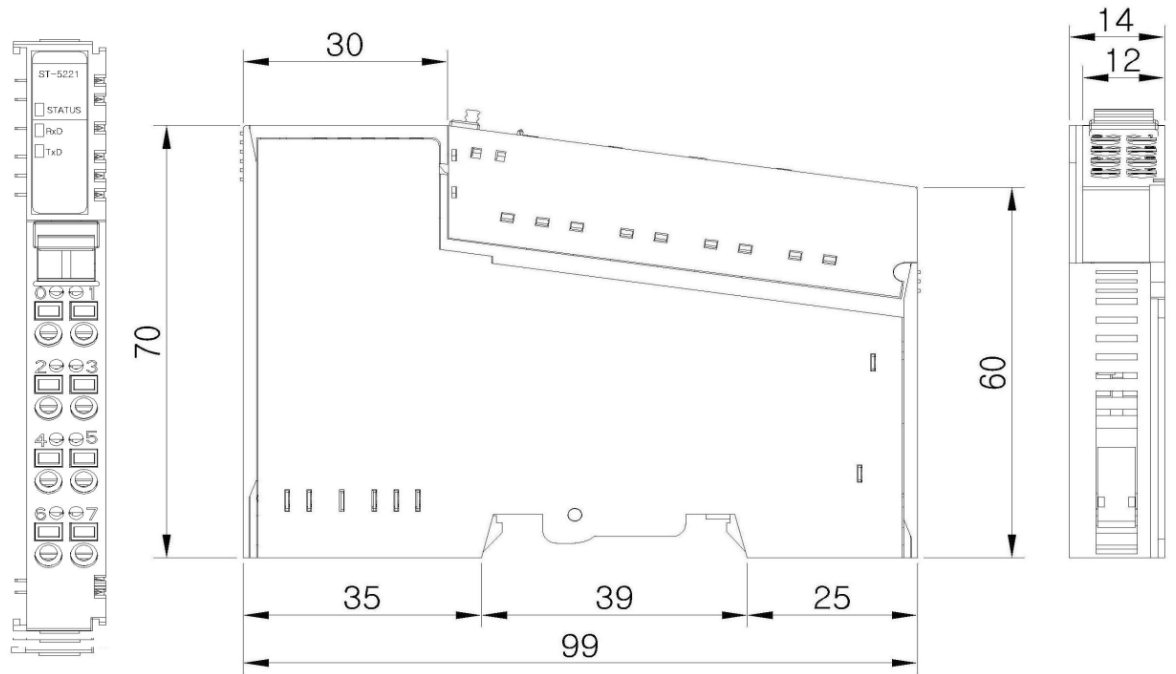

Figure 119: ST-5221 Dimension

ST-5231

Interface and Data

The following illustration shows the interface design for ST-5231.

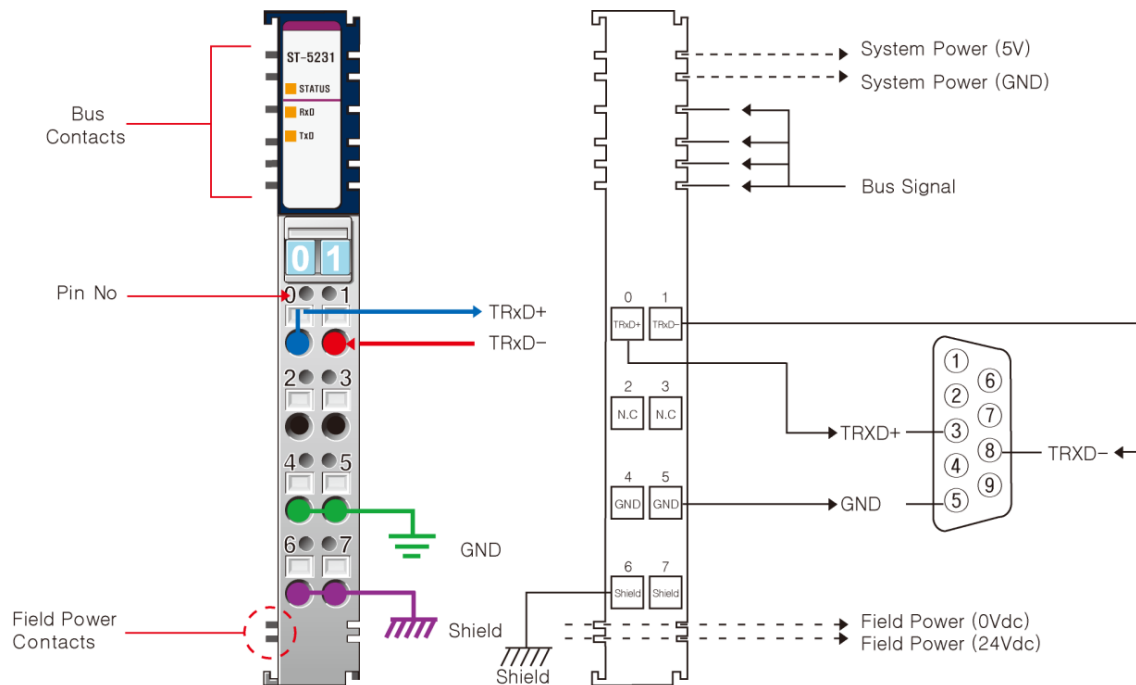

Figure 120: Serial Module: ST-5231

The following table lists the pin numbers and description for ST-5231.

Table 190: ST-5231: Pin Description

Pin Number	Description	Pin Number	Description
0	RS 485 +	1	RS 485 -
2	--	3	--
4	GND	5	GND
6	SHIELD	7	SHIELD

The following table describes the LED color and status for ST-5231.

Table 191: ST-5231: LED Color and Status

LED Name	Color	Status
RxD	Green	Received Data
TxD	Green	Transmit Data

Specification

The following table describes the Interface Specifications and the General Specifications for ST-5231.

Table 192: ST-5231: Interface and General Specifications

<i>Items</i>	<i>ST-5231</i>
Interface Specification	
Transfer Channels	TxD, RxD, Half duplex
Transfer Rate	300~115300
Data Bit	7bit, 8bit, 9bit
Parity Bit	None, Odd, Even
Stop Bit	1bit, 2bit
Flow Control	--
Bit Distortion	<1.6%
Connection	Spring force of RTB
Cable Length	1km twisted pair
Low Signal Voltage	--
High Signal Voltage	--
Isolation	Isolation Voltage: 1,000Vrms/Vac
RxD Buffer	1024Byte
TxD Buffer	256Byte
Line Impedance	120Ω
Input Image Size	6 Byte
Output Image Size	6 Byte
General Specification	
Power Dissipation (System Power)	110mA max @ 5.0 Vdc
Environment Condition	See "Environmental Specifications" in Appendix A.
Module Size	12x67x95 (WxHxL)

Dimension

The following illustration shows the dimension for ST-5231.

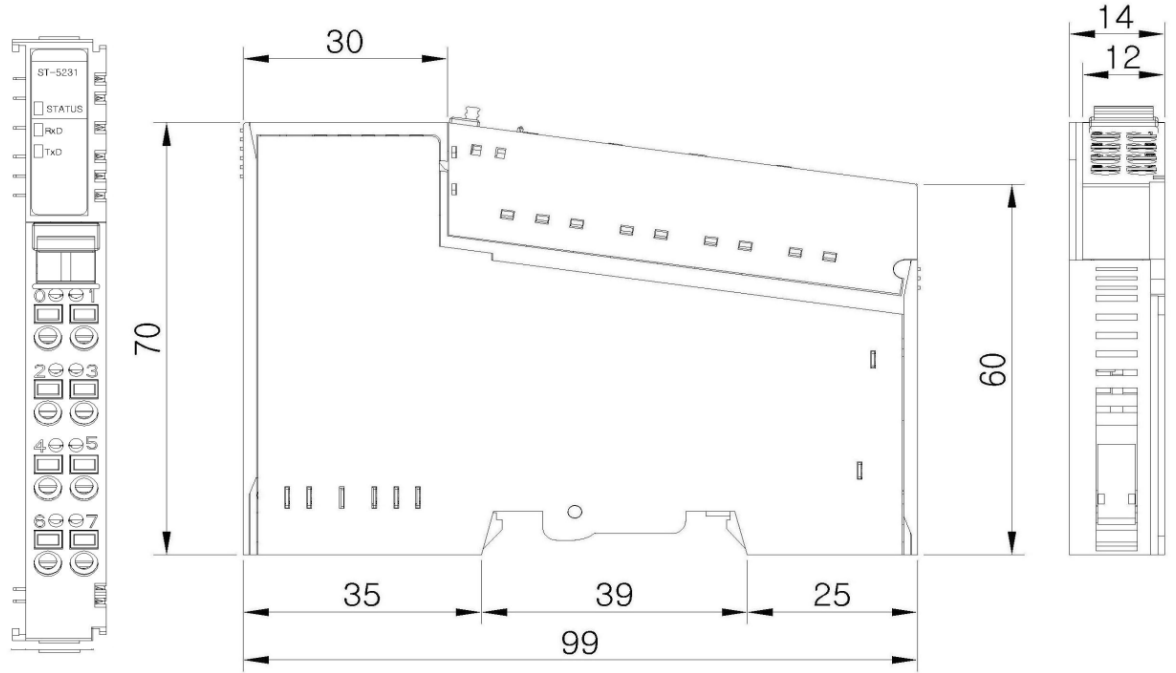

Figure 121: ST-5231 Dimension

ST-5232

Interface and Data

The following illustration shows the interface design for ST-5232.
 Department process objectives series of things that happen and have a particular result

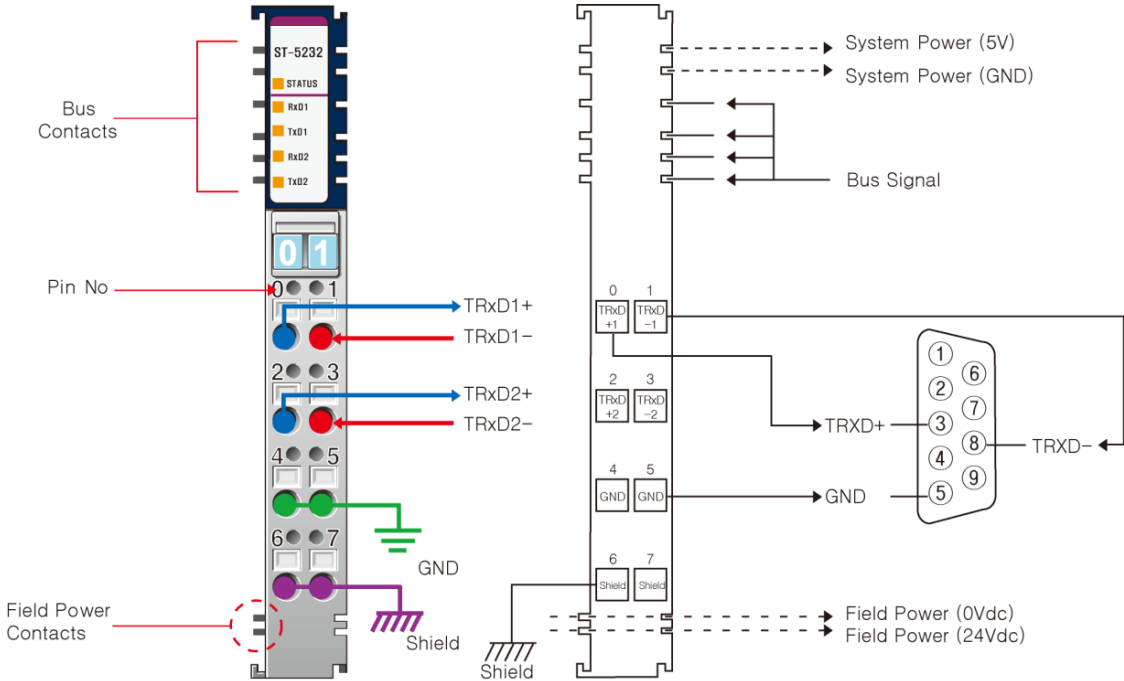

Figure 122: Serial Module: ST-5232

The following table lists the pin numbers and description for ST-5232.

Table 193: ST-5232: Pin Description

Pin Number	Description	Pin Number	Description
0	RS485 + Channel #0	1	RS485 - Channel #0
2	RS485 + Channel #1	3	RS485 - Channel #1
4	GND	5	GND
6	SHIELD	7	SHIELD

The following table describes the LED color and status for ST-5232.

Table 194: ST-5232: LED Color and Status

LED Name	Color	Status
RxD1	Green	Received Data #0
TxD1	Green	Transmit Data #0
RxD2	Green	Received Data #1
TxD2	Green	Transmit Data #1

Specification

The following table describes the Interface Specifications and the General Specifications for ST-5232.

Table 195: ST-5232: Interface and General Specifications

Items	ST-5232
Interface Specification	
Transfer Channels	TxD, RxD, Half duplex
Transfer Rate	300~115300
Data Bit	7bit, 8bit, 9bit
Parity Bit	None, Odd, Even
Stop Bit	1bit, 2bit
Flow Control	--
Bit Distortion	<1.6%
Connection	Spring force of RTB
Cable Length	1km twisted pair
Low Signal Voltage	--
High Signal Voltage	--
Isolation	Isolation Voltage: 1,000Vrms/Vac
RxD Buffer	1024Byte
TxD Buffer	256Byte
Line Impedance	120Ω
Input Image Size	12 Byte
Output Image Size	12 Byte
General Specification	
Power Dissipation (System Power)	155mA max @ 5.0 Vdc
Environment Condition	See "Environmental Specifications" in Appendix A.
Module Size	12x67x95 (WxHxL)

Dimension

The following illustration shows the dimension for ST-5232.

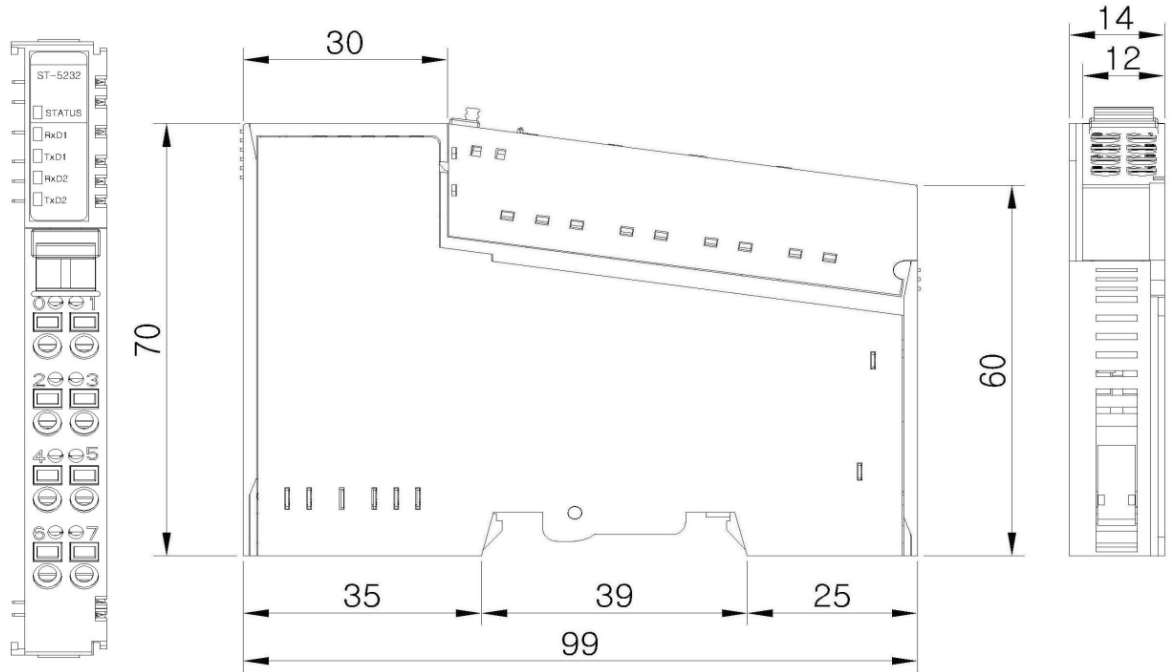

Figure 123: ST-5232 Dimension

Configuration and Operational Function

ST-5211, ST-5221, and ST-5231 - I/O Process Image Table

Input Image Data – 6 byte

	Byte Offset	Bit 7	Bit 6	Bit 5	Bit 4	Bit 3	Bit 2	Bit 1	Bit 0
#0	STATUS Byte	TPA	IL2	IL1	IL0	RBO	RR	TA	IA
#1	Data Byte #0								
#2	Data Byte #1								
#3	Data Byte #2								
#4	Data Byte #3								
#5	Data Byte #4								

- IA: Initialization Acknowledge
- TA: Transmit Acknowledge
- RR: Receive Request
- RBO: RxD Buffer Overrun Error
- There are two counters (Run counter and Index counter) which pointing at the position of RxD Buffer Run counter is increased +1 whenever RxD inputting, Index Counter is increased as much as Input Length that brought on Input Data.
- IL: Input Length
- TPA: Transmit Processing Acknowledge
- (Related Configuration Parameter: TxD Buffering).

Output Image Data – 6 byte

	Byte Offset	Bit 7	Bit 6	Bit 5	Bit 4	Bit 3	Bit 2	Bit 1	Bit 0
#0	Control Byte	TPR	OL2	OL1	OL0	--	RA	TR	IR
#1	Data Byte #0								
#2	Data Byte #1								
#3	Data Byte #2								
#4	Data Byte #3								
#5	Data Byte #4								

- IR: Initialization Request
- TR: Transmit Request
- RA: Receive Acknowledge
- OL: Output Length
- TPR: Transmit Processing Request
- (Related Configuration Parameter; TxD Buffering).

Configuration Parameter Data

Offset	Decimal Bit							
Byte #0	Bit 7	Bit 6	Bit 5	Bit 4	Bit 3	Bit 2	Bit 1	Bit 0
	Parity Bit 00 : No Parity 01 : Odd Parity 10 : Even Parity Others : Unused †Default : 00		Data Bit 00 : 7 Data bit 01 : 8 Data bit 10 : 9 Data bit Others : Unused †Default : 01		Baud Rate 0000 : 300bps 0001 : 1200bps 0010 : 2400bps 0011 : 4800bps 0100 : 9600bps (†Default Value) 0101 :19200bps 0110 :38400bps 0111 :57600bps 1000 : 115200bps Others : Unused			
Byte #1	7bit	6bit	5 bit	4 bit	3 bit	2 bit	1 bit	0 bit
	Reserved				CTS/RTS Flow Control 00 : RTS/CTS Disable 01 : TRS Enable 10 : CTS Enable 11 : RTS/CTS Enable †Default : 00 †Note 1		TxD Process 0 : Disable 1 : Enable †Default: 0 †Note 2	Stop Bit 0 : 1 bit 1 : 2 bit †Default: 0
Byte #2	7bit	6bit	5 bit	4 bit	3 bit	2 bit	1 bit	0 bit
	Reserved							
Byte #3	7bit	6bit	5 bit	4 bit	3 bit	2 bit	1 bit	0 bit
	Reserved							

Note 1: When RTS is enabled, if size of received data is greater than 80% (1024x 0.8=819) of RxD Buffer Size, RTS output is activated.

Note 2: Disable: Transmit immediately Output Data #0~Output Data #4.
 Enable: Store the value of Output Data continually at RxD Buffer of Serial Interface Module. When TPA bit and TPR bit of Control Byte and Status Byte are different, transmit all data that is saved at TxD Buffer.

ST-5212 and ST-5232

*I/O Process Image Table**Input Image Data – 12 byte*

Byte Offset		Bit 7	Bit 6	Bit 5	Bit 4	Bit 3	Bit 2	Bit 1	Bit 0
#0	STATUS Byte (1ch)	TPA	IL2	IL1	IL0	RBO	RR	TA	IA
#1	Data Byte #0 (1ch)								
#2	Data Byte #1 (1ch)								
#3	Data Byte #2 (1ch)								
#4	Data Byte #3 (1ch)								
#5	Data Byte #4 (1ch)								
#6	STATUS Byte (2ch)	TPA	IL2	IL1	IL0	RBO	RR	TA	IA
#7	Data Byte #0 (2ch)								
#8	Data Byte #1 (2ch)								
#9	Data Byte #2 (2ch)								
#10	Data Byte #3 (2ch)								
#11	Data Byte #4 (2ch)								

- IA: Initialization Acknowledge
- TA: Transmit Acknowledge
- RR: Receive Request
- RBO: RxD Buffer Overrun Error
- There are two counters(Run counter and Index counter) which pointing at the position of RxD Buffer Run counter is increased +1 whenever RxD inputting, Index Counter is increased as much as Input Length that brought on Input Data.
- IL: Input Length
- TPA: Transmit Processing Acknowledge
- (Related Configuration Parameter: TxD Buffering)

Output Image Data – 12 byte

Byte Offset		Bit 7	Bit 6	Bit 5	Bit 4	Bit 3	Bit 2	Bit 1	Bit 0
#0	Control Byte (1ch)	TPR	OL2	OL1	OL0	--	RA	TR	IR
#1	Data Byte #0 (1ch)								
#2	Data Byte #1 (1ch)								
#3	Data Byte #2 (1ch)								
#4	Data Byte #3 (1ch)								
#5	Data Byte #4 (1ch)								
#6	Control Byte (2ch)	TPR	OL2	OL1	OL0	--	RA	TR	IR
#7	Data Byte #0 (2ch)								
#8	Data Byte #1 (2ch)								
#9	Data Byte #2 (2ch)								
#10	Data Byte #3 (2ch)								
#11	Data Byte #4 (2ch)								

- IR: Initialization Request

- TR: Transmit Request
- RA: Receive Acknowledge
- OL: Output Length
- TPR: Transmit Processing Request
(Related Configuration Parameter: TxD Buffering)

Configuration Parameter Data

Offset	Decimal Bit							
Byte #0	Bit 7	Bit 6	Bit 5	Bit 4	Bit 3	Bit 2	Bit 1	Bit 0
	Parity Bit 00 : No Parity 01 : Odd Parity 10 : Even Parity Others : Unused †Default : 00		Data Bit 00 : 7 Data bit 01 : 8 Data bit 10 : 9 Data bit Others : Unused †Default : 01		Baud Rate 0000 : 300bps 0001 : 1200bps 0010 : 2400bps 0011 : 4800bps 0100 : 9600bps (†Default Value) 0101 : 19200bps 0110 : 38400bps 0111 : 57600bps 1000 : 115200bps Others : Unused			
Byte #1	7bit	6bit	5 bit	4 bit	3 bit	2 bit	1 bit	0 bit
	Reserved						TxD Process 0 : Disable 1 : Enable †Default: 0 †Note 2	Stop Bit 0 : 1 bit 1 : 2 bit †Default: 0
Byte #2	7bit	6bit	5 bit	4 bit	3 bit	2 bit	1 bit	0 bit
	Parity Bit 00 : No Parity 01 : Odd Parity 10 : Even Parity Others : Unused †Default : 00		Data Bit 00 : 7 Data bit 01 : 8 Data bit 10 : 9 Data bit Others : Unused †Default : 01		Baud Rate 0000 : 300bps 0001 : 1200bps 0010 : 2400bps 0011 : 4800bps 0100 : 9600bps (†Default Value) 0101 : 19200bps 0110 : 38400bps 0111 : 57600bps 1000 : 115200bps Others : Unused			
Byte #3	7bit	6bit	5 bit	4 bit	3 bit	2 bit	1 bit	0 bit
	Reserved						TxD Process 0 : Disable 1 : Enable †Default: 0	Stop Bit 0 : 1 bit 1 : 2 bit †Default: 0

Note 1: When RTS is enabled, if Size of received Data is greater than 80% (1024 x 0.8=819) of RxD Buffer Size, RTS output is activated.

Note 2: Disable: Transmit immediately Output Data #0~Output Data #4.

Enable: Store the value of Output Data continually at RxD Buffer of Serial Interface Module. When TPA bit and TPR bit of Control Byte and Status Byte are different, transmit all Data that is saved at TxD Buffer.

Initialization of the Serial Module

Control Byte

- Set Bit in control byte to '1'
- Receive and Transmit functions are stopped.
- RxD Buffer and TxD Buffer are erased.
- Serial Interface Module will set configuration parameter value

	Bit 7	Bit 6	Bit 5	Bit 4	Bit 3	Bit 2	Bit 1	Bit 0
Control Byte	x	x	x	x	x	x	x	IR

Status Byte

- If IA in Status Byte set to '1', Initialization of serial interface module success.

	Bit 7	Bit 6	Bit 5	Bit 4	Bit 3	Bit 2	Bit 1	Bit 0
Status Byte	x	x	x	x	x	x	x	IA

Example of Transmit and Receive Signal

Example of transmitting data (Transmit Data "Welcome")

Step #0

TR inverting (TR≠TA)

Output Length = 5

Output Data = "Welco"

	Bit 7	Bit 6	Bit 5	Bit 4	Bit 3	Bit 2	Bit 1	Bit 0
Status Byte	TPA	IL2	IL1	IL0	OR	RR	TA	IA
	x	x	x	x	x	x	0	0

	Bit 7	Bit 6	Bit 5	Bit 4	Bit 3	Bit 2	Bit 1	Bit 0
Control Byte	TPR	OL2	OL1	OL0	--	RA	TR	IR
	x	1	0	1	x	x	1	0
Output Byte #0	'W'(0x57)							
Output Byte #1	'e'(0x65)							
Output Byte #2	'l'(0x6C)							
Output Byte #3	'c'(0x63)							
Output Byte #4	'o'(0x6F)							

Step #1

Check TA bit value in Status Byte

TR=TA: transmit complete

	Bit 7	Bit 6	Bit 5	Bit 4	Bit 3	Bit 2	Bit 1	Bit 0
Status Byte	TPA	IL2	IL1	IL0	OR	RR	TA	IA
	x	x	x	x	x	x	1	0

Step #2

TR inverting (TR≠TA)

Output Length = 2

Output Data = "me"

	Bit 7	Bit 6	Bit 5	Bit 4	Bit 3	Bit 2	Bit 1	Bit 0
Control Byte	TPR	OL2	OL1	OL0	--	RA	TR	IR
	x	0	1	0	x	x	0	0
Output Byte #0	'm'(0x6D)							
Output Byte #1	'e'(0x65)							
Output Byte #2	0x00							
Output Byte #3	0x00							
Output Byte #4	0x00							

Step #3

Check TA bit value in Status Byte.

TR=TA: transmit complete.

	Bit 7	Bit 6	Bit 5	Bit 4	Bit 3	Bit 2	Bit 1	Bit 0
Status Byte	TPA	IL2	IL1	IL0	OR	RR	TA	IA
	x	x	x	x	x	x	0	0

Step #4

Check TA bit value in Status Byte.

TR=TA: transmit complete.

	Bit 7	Bit 6	Bit 5	Bit 4	Bit 3	Bit 2	Bit 1	Bit 0
Status Byte	TPA	IL2	IL1	IL0	OR	RR	TA	IA
	x	x	x	x	x	x	1	0

Example of receiving data (Receive Data "Welcome")**Step #0**

RR=RA

	Bit 7	Bit 6	Bit 5	Bit 4	Bit 3	Bit 2	Bit 1	Bit 0
Status Byte	TPA	IL2	IL1	IL0	OR	RR	TA	IA
	x	x	x	x	x	0	x	0

	Bit 7	Bit 6	Bit 5	Bit 4	Bit 3	Bit 2	Bit 1	Bit 0
Control Byte	TPR	OL2	OL1	OL0	--	RA	TR	IR
	x	1	0	1	x	x	1	0

Step #1

RA inverting (RA≠RR)

	Bit 7	Bit 6	Bit 5	Bit 4	Bit 3	Bit 2	Bit 1	Bit 0
Control Byte	TPA	OL2	OL1	OL0	--	RA	TR	IR
	x	x	x	x	x	1	X	0

Step #2

RA inverting (RA=RR)

Input Length = 5

Input Data = "Welco"

	Bit 7	Bit 6	Bit 5	Bit 4	Bit 3	Bit 2	Bit 1	Bit 0
Control Byte	TPR	OL2	OL1	OL0	--	RA	TR	IR
	x	1	0	1	x	1	x	0
Input Byte #0	'W'(0x57)							

Input Byte #1	'e'(0x65)
Input Byte #2	'l'(0x6C)
Input Byte #3	'c'(0x63)
Input Byte #4	'o'(0x6F)

Step #3

RA inverting (RA≠RR)

	Bit 7	Bit 6	Bit 5	Bit 4	Bit 3	Bit 2	Bit 1	Bit 0
Control Byte	TPR	OL2	OL1	OL0	--	RA	TR	IR
	x	x	x	x	x	0	X	0

Step #4

RA inverting (RA=RR)

Input Length = 2

Input Data = "me"

	Bit 7	Bit 6	Bit 5	Bit 4	Bit 3	Bit 2	Bit 1	Bit 0
Status Byte	TPR	OL2	OL1	OL0	--	RA	TR	IR
	x	0	1	0	x	0	x	0
Input Byte #0	'm'(0x6D)							
Input Byte #1	'e'(0x65)							
Input Byte #2	0x00							
Input Byte #3	0x00							
Input Byte #4	0x00							

Example of Transmitting and Receiving data (Transmit: "Welcome", Receive: "Welcome")

Step #0 (Transmit)

TR inverting (TR≠TA)

Output Length = 5

Output Data = "Welco"

	Bit 7	Bit 6	Bit 5	Bit 4	Bit 3	Bit 2	Bit 1	Bit 0
Control Byte	TPR	OL2	OL1	OL0	--	RA	TR	IR
	x	1	0	1	x	x	1	0
Output Byte #0	'W'(0x57)							
Output Byte #1	'e'(0x65)							
Output Byte #2	'l'(0x6C)							
Output Byte #3	'c'(0x63)							
Output Byte #4	'o'(0x6F)							

Step #1

Check TA bit value in Status Byte.

TR=TA: transmit complete.

	Bit 7	Bit 6	Bit 5	Bit 4	Bit 3	Bit 2	Bit 1	Bit 0
Status Byte	TPA	IL2	IL1	IL0	OR	RR	TA	IA
	x	x	x	x	x	x	1	0

Step #2

TR inverting (TR≠TA)

Output Length = 2

Output Data = "me"

	Bit 7	Bit 6	Bit 5	Bit 4	Bit 3	Bit 2	Bit 1	Bit 0
Control Byte	TPR	OL2	OL1	OL0	--	RA	TR	IR
	x	0	1	0	x	x	0	0
Output Byte #0	'm'(0x6D)							
Output Byte #1	'e'(0x65)							
Output Byte #2								
Output Byte #3								
Output Byte #4								

Step #3

Check TA bit value in Status Byte.

TR=TA: transmit complete.

	Bit 7	Bit 6	Bit 5	Bit 4	Bit 3	Bit 2	Bit 1	Bit 0
Status Byte	TPA	IL2	IL1	IL0	OR	RR	TA	IA
	x	x	x	x	x	x	0	0

Step #4 (Receive)

Check (RR=RA)

	Bit 7	Bit 6	Bit 5	Bit 4	Bit 3	Bit 2	Bit 1	Bit 0
Status Byte	TPA	IL2	IL1	IL0	OR	RR	TA	IA
	x	x	x	x	x	0	x	0

	Bit 7	Bit 6	Bit 5	Bit 4	Bit 3	Bit 2	Bit 1	Bit 0
Control Byte	TPR	OL2	OL1	OL0	--	RA	TR	IR
	x	x	x	x	x	0	x	0

Step #5

RA inverting (RA≠RR)

	Bit 7	Bit 6	Bit 5	Bit 4	Bit 3	Bit 2	Bit 1	Bit 0
Control Byte	TPR	OL2	OL1	OL0	--	RA	TR	IR
	x	x	x	x	x	1	x	0

Step #6

RA inverting (RA=RR)

Input Length = 5

	Bit 7	Bit 6	Bit 5	Bit 4	Bit 3	Bit 2	Bit 1	Bit 0
Status Byte	TPR	OL2	OL1	OL0	--	RA	TR	IR
	x	1	0	1	x	1	x	0

Step #7 (Receive)

Check (RR=RA)

	Bit 7	Bit 6	Bit 5	Bit 4	Bit 3	Bit 2	Bit 1	Bit 0
Status Byte	TPA	IL2	IL1	IL0	OR	RR	TA	IA
	x	x	x	x	x	0	x	0

Check Input Data = "Welco"

	Bit 7	Bit 6	Bit 5	Bit 4	Bit 3	Bit 2	Bit 1	Bit 0
Status Byte	TPR	OL2	OL1	OL0	--	RA	TR	IR
	x	1	0	1	x	1	x	0
Input Byte #0	W							
Input Byte #1	e							
Input Byte #2	l							
Input Byte #3	c							
Input Byte #4	o							

Step #8

RA inverting (RA=RR)

Input Length = 2

Check Input Data = "me"

	Bit 7	Bit 6	Bit 5	Bit 4	Bit 3	Bit 2	Bit 1	Bit 0
Status Byte	TPR	OL2	OL1	OL0	--	RA	TR	IR
	x	0	1	0	x	0	x	0
Input Byte #0	'm'							
Input Byte #1	'e'							
Input Byte #2								
Input Byte #3								
Input Byte #4								

Example of TPR and TPA (“Welcome”)

Step #0 (Transmit)

TxD Process data in Configuration Parameter set to “1” (Enable)

Step #1

RA inverting (RA≠RR)

Output Length = 5

Output Data = “Welco”

	Bit 7	Bit 6	Bit 5	Bit 4	Bit 3	Bit 2	Bit 1	Bit 0
Status Byte	TPA	IL2	IL1	IL0	OR	RR	TA	IA
	0	x	x	x	x	x	0	0

	Bit 7	Bit 6	Bit 5	Bit 4	Bit 3	Bit 2	Bit 1	Bit 0
Control Byte	TPR	OL2	OL1	OL0	--	RA	TR	IR
	0	1	0	1	x	x	1	0
Output Byte #0	'W'(0x57)							
Output Byte #1	'e'(0x65)							
Output Byte #2	'l'(0x6C)							
Output Byte #3	'c'(0x63)							
Output Byte #4	'o'(0x6F)							

Step #2

Check TA bit value in Status Byte.

TR=TA: transmit complete.

	Bit 7	Bit 6	Bit 5	Bit 4	Bit 3	Bit 2	Bit 1	Bit 0
Status Byte	TPA	IL2	IL1	IL0	OR	RR	TA	IA
	0	x	x	x	x	x	1	0

TxD Buffer

Offset	TxD Buffer Data
0	W(0x57)
1	e(0x65)
2	l(0x6C)
3	c(0x63)
4	o(0x6F)
5	
6	
7	
8	
:	:

:	:
:	:
253	
254	
255	

Step #3

RA inverting (RA≠RR)
 Output Length = 2
 Output Data = "me"

	Bit 7	Bit 6	Bit 5	Bit 4	Bit 3	Bit 2	Bit 1	Bit 0
Control Byte	TPR	OL2	OL1	OL0	--	RA	TR	IR
	0	0	1	0	x	x	0	0
Output Byte #0	'm'(0x6D)							
Output Byte #1	'e'(0x65)							
Output Byte #2								
Output Byte #3								
Output Byte #4								

Step #4

Check TA bit value in Status Byte.
 TR=TA: transmit complete

	Bit 7	Bit 6	Bit 5	Bit 4	Bit 3	Bit 2	Bit 1	Bit 0
Status Byte	TPA	IL2	IL1	IL0	OR	RR	TA	IA
	0	x	x	x	x	x	0	0

TxD Buffer

Offset	TxD Buffer Data
0	W(0x57)
1	e(0x65)
2	l(0x6C)
3	c(0x63)
4	o(0x6F)
5	m(0x5D)
6	e(0x65)
7	
8	
:	:
:	:
:	:
253	
254	
255	

Step #5

TPR inverting (TPR≠TPA)

	Bit 7	Bit 6	Bit 5	Bit 4	Bit 3	Bit 2	Bit 1	Bit 0
Control Byte	TPR	OL2	OL1	OL0	--	RA	TR	IR
	1	0	1	0	x	x	0	0

Transfer all TxD Buffer data (TxD Buffer empty)

Offset	TxD Buffer Data
0	
1	
2	
3	
4	
5	
6	
7	
8	
:	:
:	:
:	:
253	
254	
255	

Step #6

Check TPA bit value in Status Byte.

TPR=TPA: transmit complete

	Bit 7	Bit 6	Bit 5	Bit 4	Bit 3	Bit 2	Bit 1	Bit 0
Status Byte	TPA	IL2	IL1	IL0	OR	RR	TA	IA
	1	x	x	x	x	x	0	0

SSI Interface

ST-5351

Interface and Data

The following illustration shows the interface design for ST-5351.

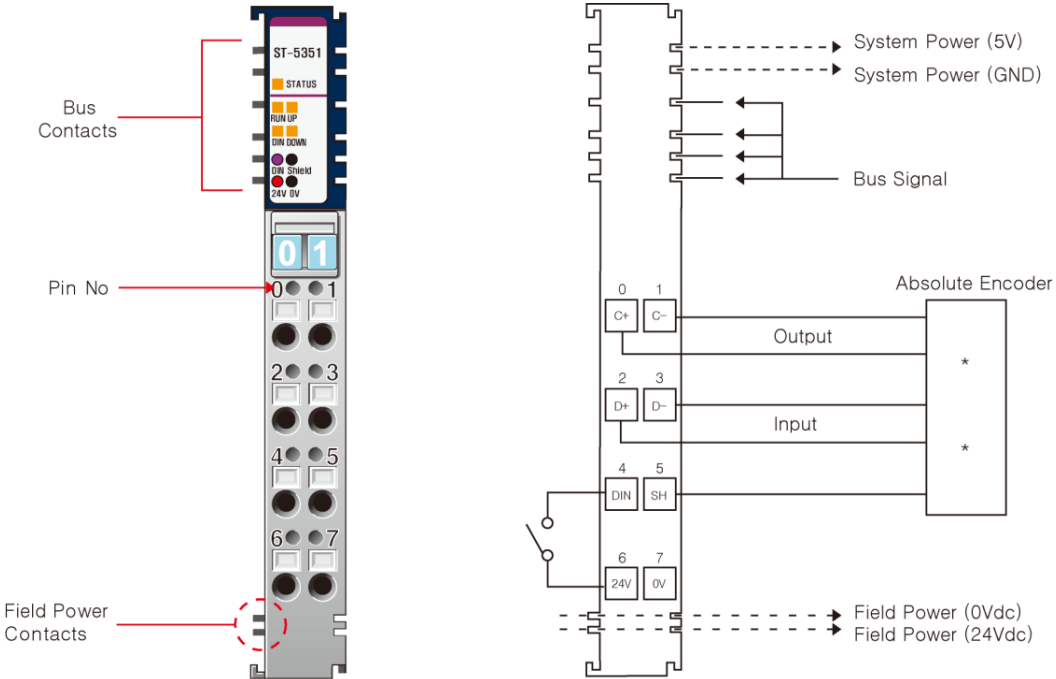

Figure 124: SSI Interface: ST-5351

The following table lists the pin numbers and description for ST-5351.

Table 196: ST-5351: Pin Description

Pin Number	Description	Pin Number	Description
0	C+ (RS422 Differential Output)	1	C- (RS422 Differential Output)
2	D+ (RS422 Differential Input)	3	D- (RS422 Differential Input)
4	DIN (Digital Input, Positive Logic Type)	5	Shield
6	Field Power 24V	7	Field Power 0V, Common

Specification

The following table describes the Module Specifications and the General Specifications for ST-5351.

Table 197: ST-5351: Module and General Specifications

Items	Specification
Module Specification	
Number of Channel	1 Ch SSI Interface
Indicators	1 Green/Red RSTi Bus Status 4 LEDs RUN/WARN, UP DIN, DOWN
SSI Data Rate	62.5K,100K,125K,250K,500K,1M,2Mbps
SSI Data Width	Max. 30bit
SSI Data Delay Time	20usec~10msec
SSI Output	C+,C- RS422 Differential Output
SSI Input	D+,D- RS422 Differential Input
SSI Data Code Type	Gray Code or Natural Binary
Digital Input	24Vdc Input nominal, Positive Logic Type Voltage Range : 11 ~ 28.8Vdc
Diagnostic	Field Power, SSI Frame
Common Type	1 Common, 1 Shield
General Specification	
Power Dissipation	Maximum 150mA @ 5.0Vdc
Isolation	I/O to Logic: Photo coupler isolation I/O to Field Power : Non-Isolation
Field Power	Supply Voltage : 24Vdc nominal Voltage Range : 11~28.8Vdc Power Dissipation: Maximum 40mA @24Vdc
Wiring	I/O Cable Maximum 2.0mm ² (AWG#14)
Weight	70g
Module Size	12mm x 99mm x 70mm
Environment Condition	See "Environmental Specifications" in Appendix A.

Dimension

The following illustration shows the dimension for ST-5351.

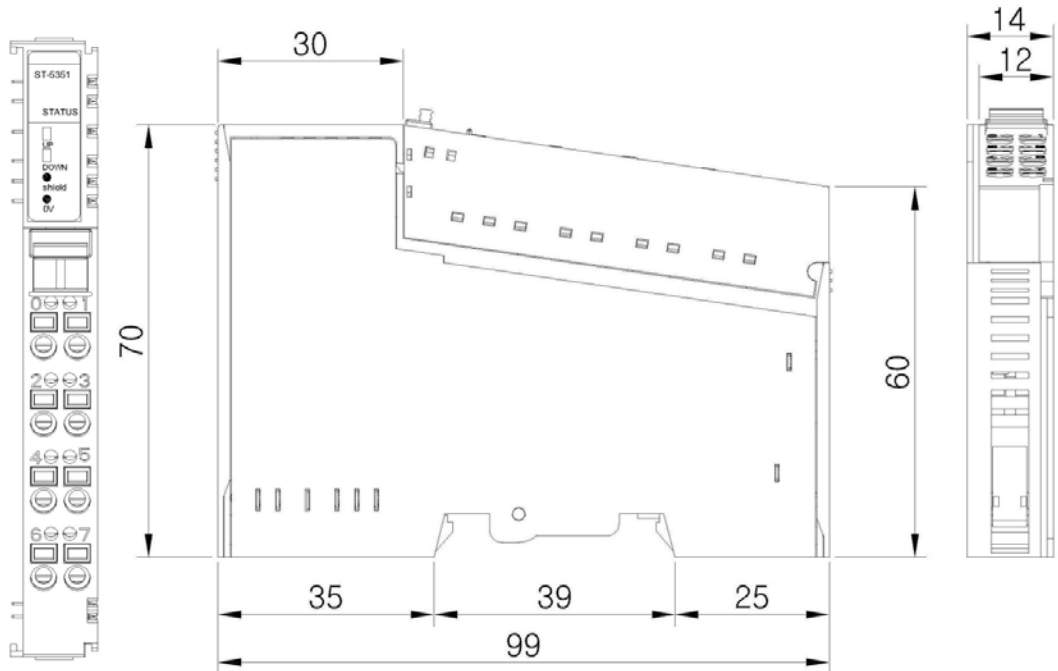

Figure 125: ST-5351 Dimension

Configuration and Operational Function

Input Image Data – 10 byte

Byte	Bit 7	Bit 6	Bit 5	Bit 4	Bit 3	Bit 2	Bit 1	Bit 0
0	Current SSI Data LL							
1	Current SSI Data LH							
2	Current SSI Data HL							
3	Current SSI Data HH							
4	Latched SSI Data LL							
5	Latched SSI Data LH							
6	Latched SSI Data HL							
7	Latched SSI Data HH							
8	RUN	WARN	LDF	---	DEC	INC	---	DIN
9	---	---	---	WPF	---	---	WSSIF	WSSID

- SSI Data word is a 32bit-wide data.
- RUN: SSI Clock Output Enabled Flag
- WARN: Warning. Any warning has occurred, WFP, WSSIF or WSSID.
- LDF: Latched Data Flag, if terminal's DIN goes OFF=>ON, sets the flag and updates Latched SSI Data.
- DEC: SSI Data Decrement. It was set, it lasts until INC.
- INC: SSI Data Increment. It was set, it lasts DEC.
- DIN: Digital Input Current Status.
- WFP: Warning of Field Power (SSI Power).
- WSSIF: Warning of SSI Frame. The last bit of frame data is not trailed with 0.
- WSSID: Warning of SSI Data. SSI Data is 0 during gap of frames. Generally when invalid wiring or cross wiring.

Output Image Data – 2 byte

Byte	Bit 7	Bit 6	Bit 5	Bit 4	Bit 3	Bit 2	Bit 1	Bit 0
0	RUN	GRAY	LDFCLR	SSI Data Length (0~30)				
1	SSI Data Delay Time Selection				SSI Data Rate Selection			

- RUN : SSI Clock Output Command, 1:Run, 0:Stop
- GRAY: Conversion Binary to Gray code. 1:Gray, 0:Binary
- It has effect on Current SSI Data and Latched SSI Data.
- LDFCLR: LDF (Latched Data Flag) Clear, it acts on both edge (0=>1, 1=>0).
- SSI Data Length: Sensor Resolution Bit + Sensor Number of turn Bit.
- Example) Sensor Resolution (Step/Revolution)=8192 => 13bit, Sensor Number of turn=4092 => 12bit
- SSI Data Length must be 25 (13bit + 12bit).

■ SSI Data Rate Selection

<i>Value</i>	<i>Description</i>
0 (B'0000)	125Kbps (default)
1 (B'0001)	62.5Kbps
2 (B'0010)	100Kbps
3 (B'0011)	125Kbps
4 (B'0100)	250Kbps
5 (B'0101)	500Kbps
6 (B'0110)	1Mbps
7 (B'0111)	2Mbps

■ SSI Data Delay Time Selection

Value	62.5K	100K	125K	250K	500K	1M	2M
0 (B'0000)	300usec (default)						
1 (B'0001)	400usec	300usec	200usec	100usec	70usec	35usec	20usec
2 (B'0010)	400usec	300usec	200usec	100usec	70usec	35usec	
3 (B'0011)	400usec	300usec	200usec	100usec	70usec		
4 (B'0100)	400usec	300usec	200usec	100usec			
5 (B'0101)	400usec	300usec	200usec				
6 (B'0110)	400usec	300usec					
7 (B'0111)	400usec						
8 (B'1000)	500usec						
9 (B'1001)	750usec						
10 (B'1010)	1msec						
11 (B'1011)	2msec						
12 (B'1100)	3msec						
13 (B'1101)	4msec						
14 (B'1110)	5msec						
15 (B'1111)	10msec						

Configuration parameter Data

Byte	Bit 7	Bit 6	Bit 5	Bit 4	Bit 3	Bit 2	Bit 1	Bit 0
0	Reserved							

PWM Output Module

ST-5422

Interface and Data

The following illustration shows the interface design for ST-5422.

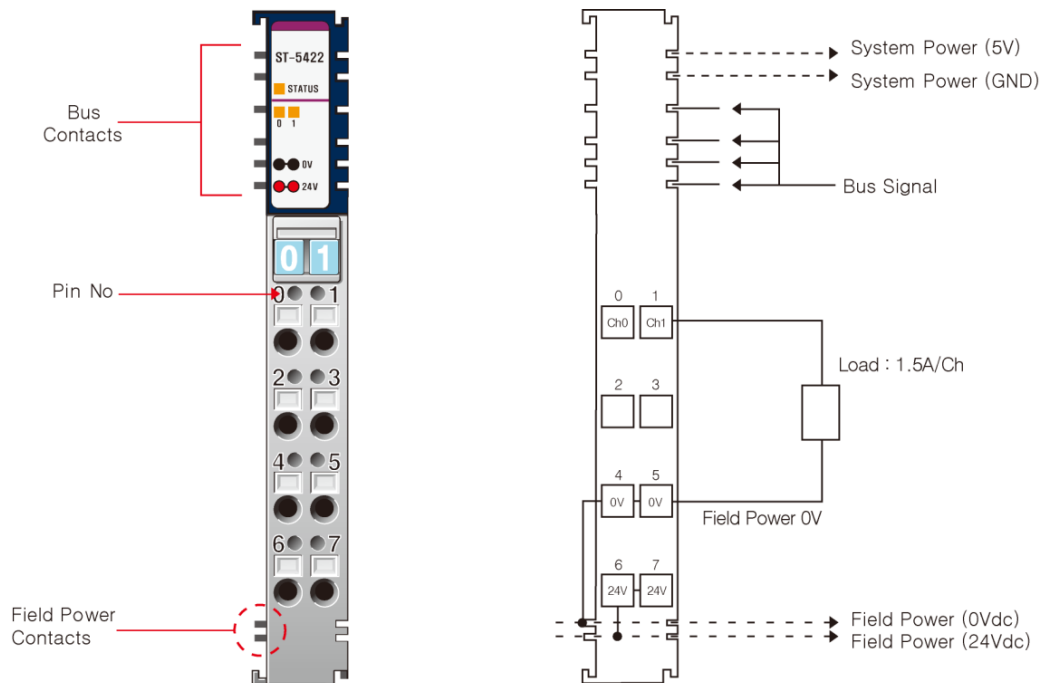

Figure 126: PWM Output Module: ST-5422

The following table lists the pin numbers and description for ST-5422.

Table 198: ST-5422: Pin Description

<i>Pin Number</i>	<i>Description</i>	<i>Pin Number</i>	<i>Description</i>
0	PWM Output Channel 0	1	PWM Output Channel 1
2	-	3	-
4	Field Power 0V, Common	5	Field Power 0V, Common
6	Field Power 24V	7	Field Power 24V

Dimension

The following illustration shows the dimension for ST-5422.

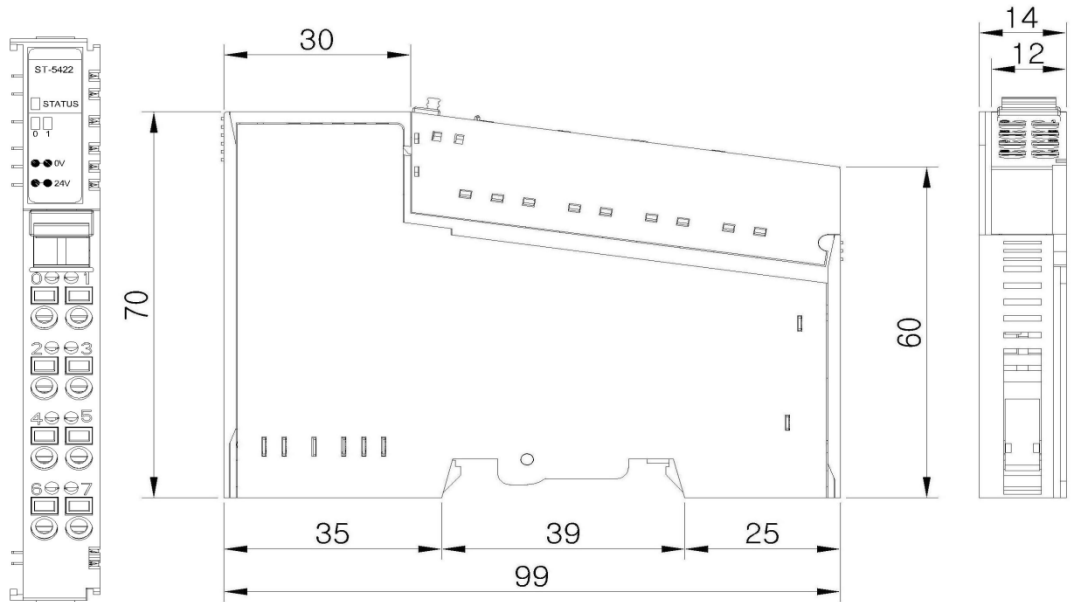

Figure 127: ST-5422 Dimension

Configuration and Operational Function

I/O Process Image Table

Input Image Data – 2 byte

Byte	Bit 7	Bit 6	Bit 5	Bit 4	Bit 3	Bit 2	Bit 1	Bit 0
0	Reserved							
1	Reserved							

Output Image Data – 6 byte

Byte	Bit 7	Bit 6	Bit 5	Bit 4	Bit 3	Bit 2	Bit 1	Bit 0
0	Frequency Ch#0,1 Low Byte							
1	Frequency Ch#0,1 High Byte							
2	Duty Ch#0 Low Byte							
3	Duty Ch#0 High Byte							
4	Duty Ch#1 Low Byte							
5	Duty Ch#1 High Byte							

- Ch#0 & 1 are using the same frequency.
- Range of each Duty is 0(0.0%) ~ 1000(100.0%). If Duty value is 250, then Duty rate is 25.0%

Configuration Parameter Data

Byte	Bit 7	Bit 6	Bit 5	Bit 4	Bit 3	Bit 2	Bit 1	Bit 0
0	Reserved							
1	Reserved							

Compared Duty Rate

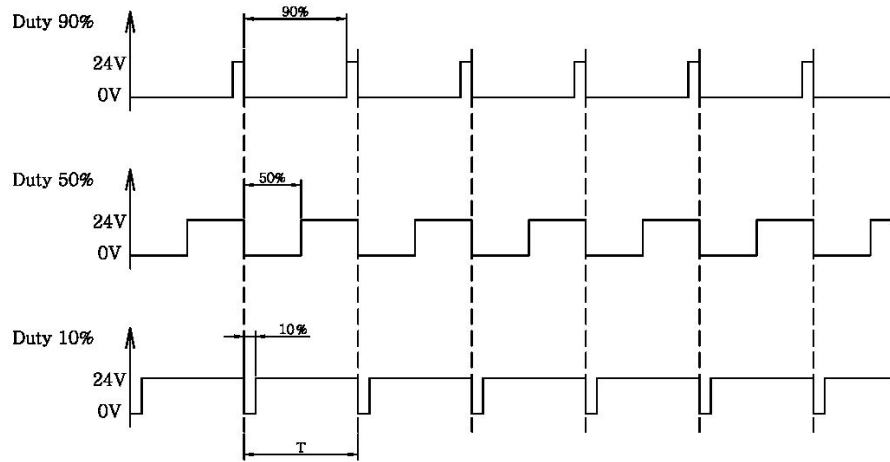

Figure 128: Timing Waveforms

T = Time (If Frequency = 10 KHz then T= 0.1ms)

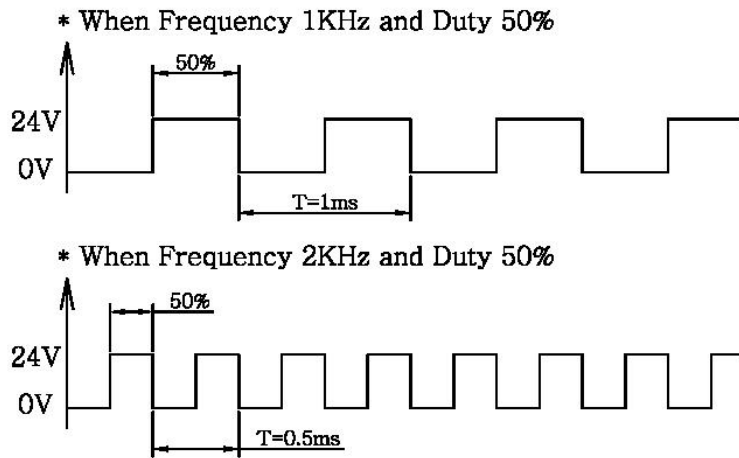

Figure 129: Timing Waveforms

ST-5442

Interface and Data

The following illustration shows the interface design for ST-5442.

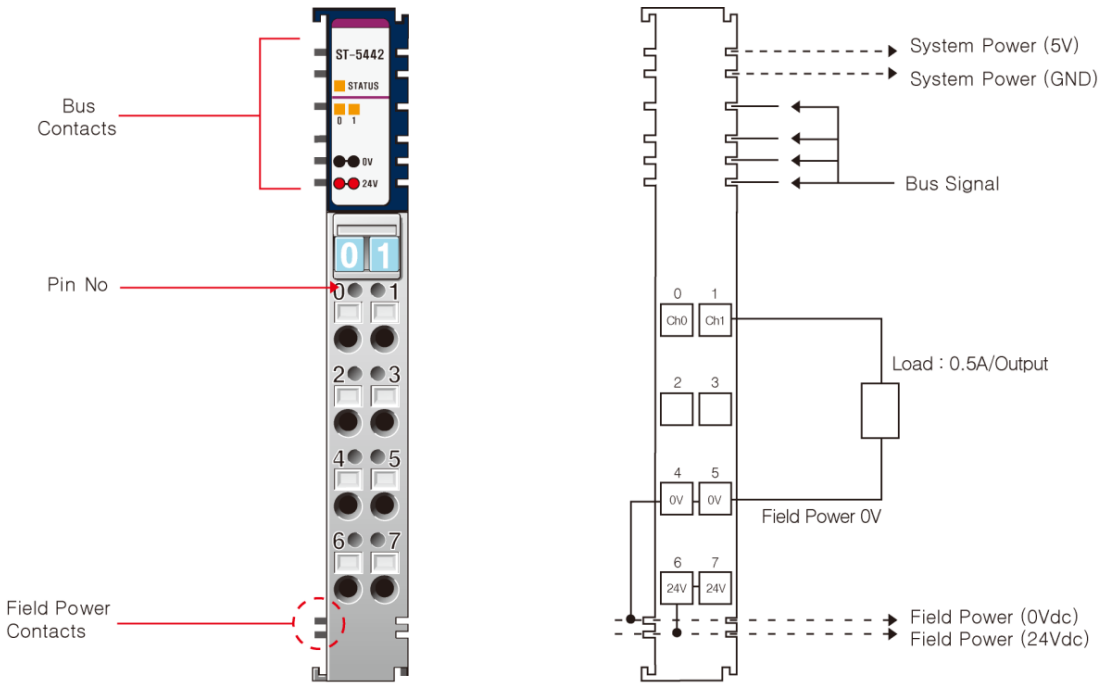

Figure 130: PWM Output Module: ST-5442

The following table lists the pin numbers and description for ST-5442.

Table 199: ST-5442: Pin Description

Pin Number	Description	Pin Number	Description
0	PWM Output Channel #0	1	PWM Output Channel #1
2	---	3	---
4	Field Power 0V, Common	5	Field Power 0V, Common
6	Field Power 24V	7	Field Power 24V

Specification

The following table describes the Output Specifications and the General Specifications for ST-5422.

Table 200: ST-5422: Output and General Specifications

Items	Specification
Output Specification	
Number of Outputs	2 Channel, Positive Logic Type
Indicators	1 Green/Red RSTi Bus Status 2 Channel LEDs
Output Current	1.5A/Ch, 3A/All Channel, short protection.
Output Inrush Current	Maximum 2A, 100ms / Ch
PWM Frequency	1~2500Hz±0.5%
PWM Duty	0.0~100.0%±1.0% (0.1%/1LSB), Ton>5us, Toff>5us
Diagnostic	Short Protection
Common Type	2 Common
General Specification	
Power Dissipation	Maximum 150mA @ 5.0Vdc
Isolation	I/O to Logic: Photo coupler isolation I/O to Field Power : Non-Isolation
Field Power	Supply Voltage: 24Vdc nominal Voltage Range: 18~28.8Vdc Power Dissipation : Maximum 50mA @24Vdc except Load
Wiring	I/O Cable Maximum 2.0mm ² (AWG 14)
Weight	70g
Module Size	12mm x 99mm x 70mm
Environment Condition	See "Environmental Specifications" in Appendix A.

Dimension

The following illustration shows the dimension for ST-5442.

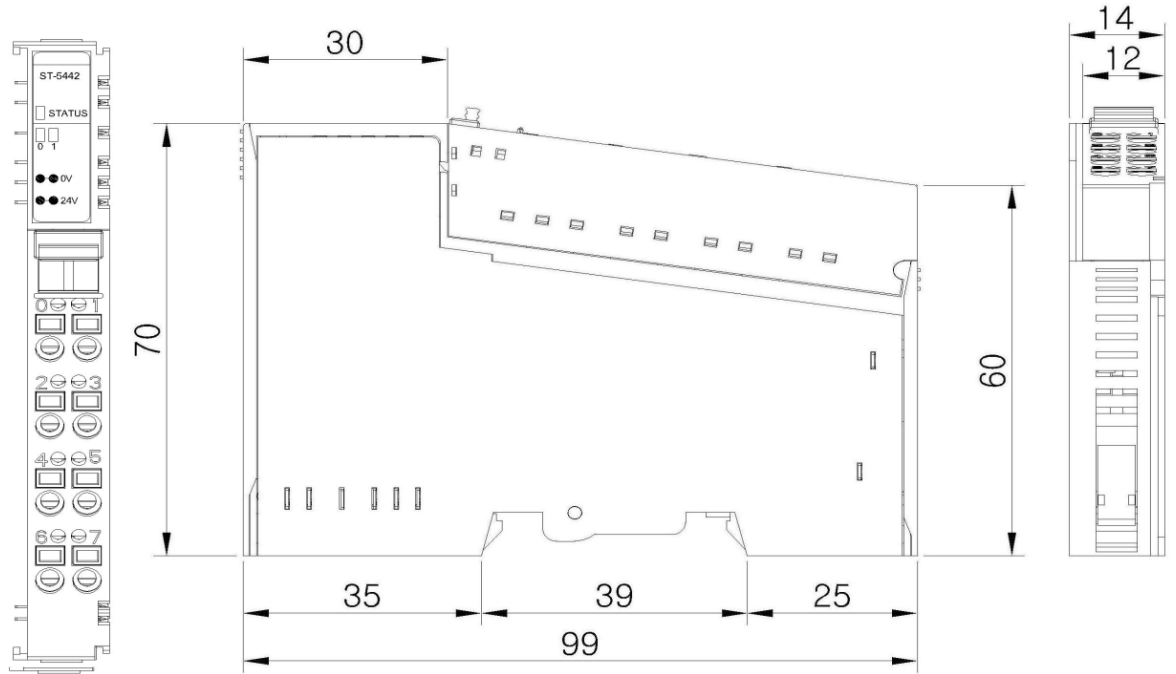

Figure 131: ST-5442 Dimension

Configuration and Operational Function

I/O Process Image Table

Input Image Data – 2 byte

Byte	Bit 7	Bit 6	Bit 5	Bit 4	Bit 3	Bit 2	Bit 1	Bit 0
0	Reserved							
1	Reserved							

Output Image Data – 6 byte

Byte	Bit 7	Bit 6	Bit 5	Bit 4	Bit 3	Bit 2	Bit 1	Bit 0
0	Frequency Ch#0,1 Low Byte							
1	Frequency Ch#0,1 High Byte							
2	Duty Ch#0 Low Byte							
3	Duty Ch#0 High Byte							
4	Duty Ch#1 Low Byte							
5	Duty Ch#1 High Byte							

- Ch#0 & 1 are using the same frequency.
- Range of each Duty is 0(0.0%) ~ 1000(100.0%). If Duty value is 250, then Duty rate is 25.0%

Configuration Parameter Data

Byte	Bit 7	Bit 6	Bit 5	Bit 4	Bit 3	Bit 2	Bit 1	Bit 0
0	Reserved							
1	Reserved							

ST-5444

Interface and Data

The following illustration shows the interface design for ST-5444.

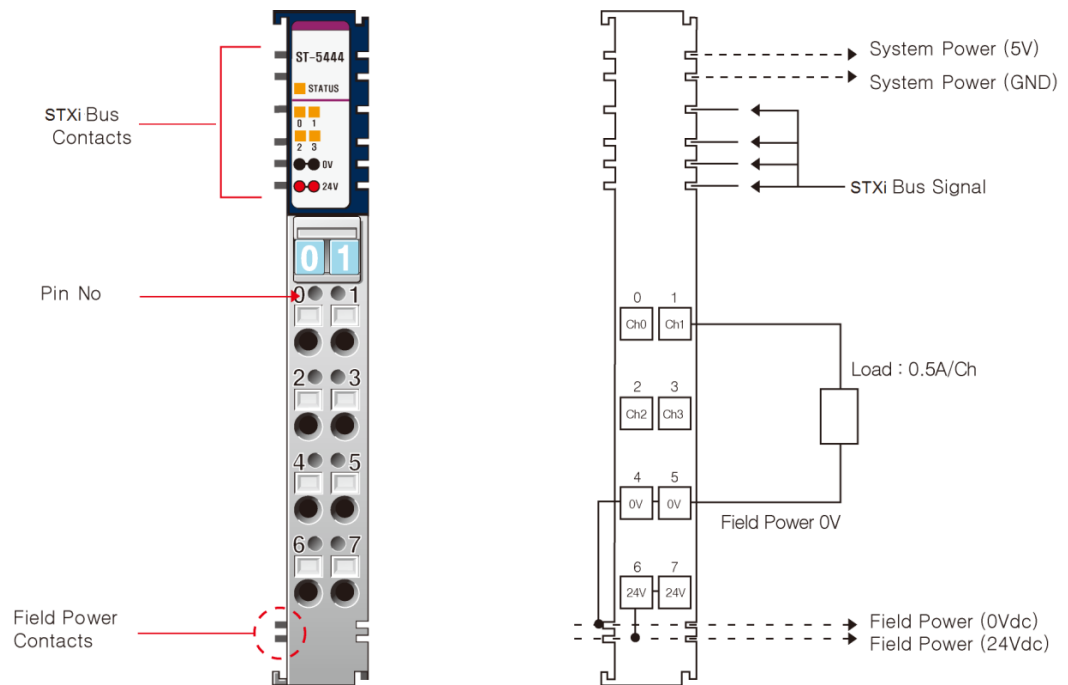

Figure 132: PWM Output Module: ST-5444

The following table lists the pin numbers and description for ST-5444.

Table 201: ST-5444: Pin Description

Pin Number	Description	Pin Number	Description
0	PWM Output Channel #0	1	PWM Output Channel #1
2	PWM Output Channel #2	3	PWM Output Channel #3
4	Field Power 0V, Common	5	Field Power 0V, Common
6	Field Power 24V	7	Field Power 24V

Specification

The following table describes the Output Specifications and the General Specifications for ST-5444.

Table 202: ST-5444: Output and General Specifications

Items	Specification
Output Specification	
Number of Outputs	4 Channel, Positive Logic Type
Indicators	1 Green/Red RSTi Bus Status 4 Channel LEDs
Output Current	0.5A/Ch, 2A/All Channel, short protection.
Output Inrush Current	Maximum 1.5A, 100ms / Ch
PWM Frequency	1~2500Hz±0.5%
PWM Duty	0.0~100.0%±1.0% (0.1%/1LSB), Ton>5us, Toff>5us
Diagnostic	Short Protection
Common Type	2 Common
General Specification	
Power Dissipation	Maximum 150mA @ 5.0Vdc
Isolation	I/O to Logic : Photo coupler isolation I/O to Field Power : Non-Isolation
Field Power	Supply Voltage: 24Vdc nominal Voltage Range: 18 ~ 28.8Vdc Power Dissipation: Maximum 50mA@24Vdc except Load
Wiring	I/O Cable Maximum 2.0mm (minimum lead)
Weight	70g
Module Size	12mm x 99mm x 70mm
Environment Condition	See "Environmental Specifications" in Appendix A.

Dimension

The following illustration shows the dimension for ST-5444.

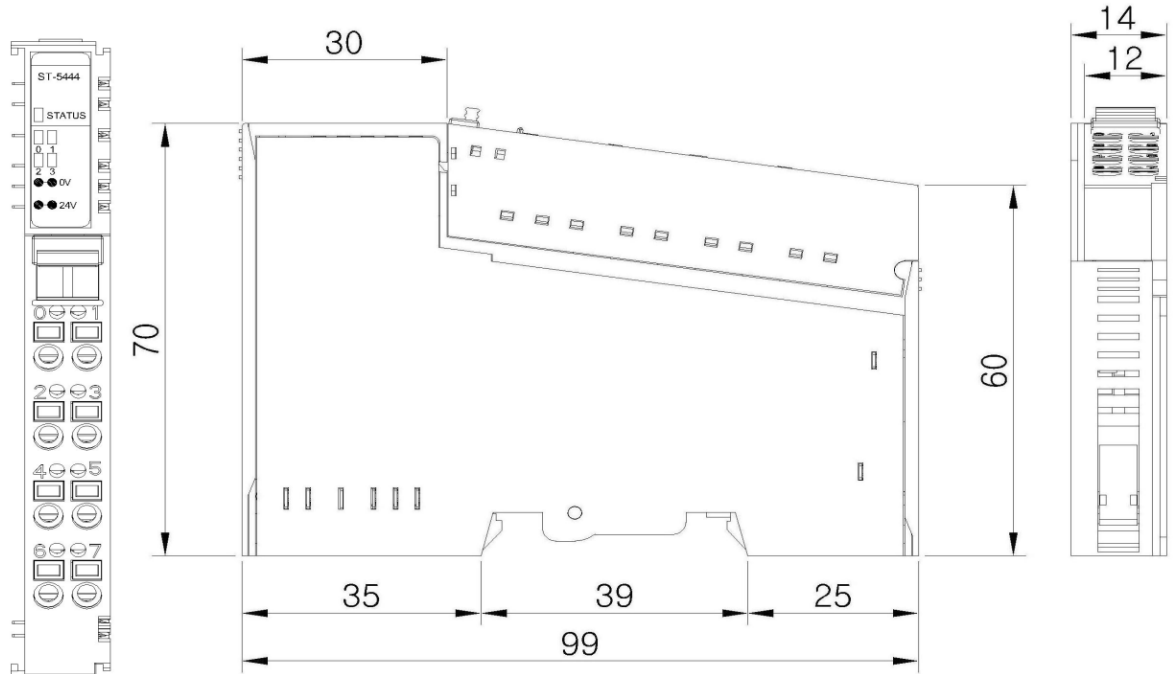

Figure 133: ST-5444 Dimension

Configuration and Operational Function

I/O Process Image Table

Input Image Data – 4 byte

Byte	Bit 7	Bit 6	Bit 5	Bit 4	Bit 3	Bit 2	Bit 1	Bit 0
0	Reserved							
1	Reserved							
2	Reserved							
3	Reserved							

Output Image Data – 12 byte

Byte	Bit 7	Bit 6	Bit 5	Bit 4	Bit 3	Bit 2	Bit 1	Bit 0
0	Frequency Ch#0,1 Low Byte							
1	Frequency Ch#0,1 High Byte							
2	Duty Ch#0 Low Byte							
3	Duty Ch#0 High Byte							
4	Duty Ch#1 Low Byte							
5	Duty Ch#1 High Byte							
6	Frequency Ch#2, 3 Low Byte							
7	Frequency Ch#2, 3 High Byte							
8	Duty Ch#2 Low Byte							
9	Duty Ch#2 High Byte							
10	Duty Ch#3 Low Byte							
11	Duty Ch#3 High Byte							

- Ch#0 & 1 are using the same frequency.
- Ch#2, 3 are using the same frequency.
- Range of each Duty is 0(0.0%) ~ 1000(100.0%). If Duty value is 250, then duty rate is 25.0%

Configuration Parameter Data

Byte	Bit 7	Bit 6	Bit 5	Bit 4	Bit 3	Bit 2	Bit 1	Bit 0
0	Reserved							
1	Reserved							

Pulse Output Module

ST-5641

Interface and Data

The following illustration shows the interface design for ST-5641.

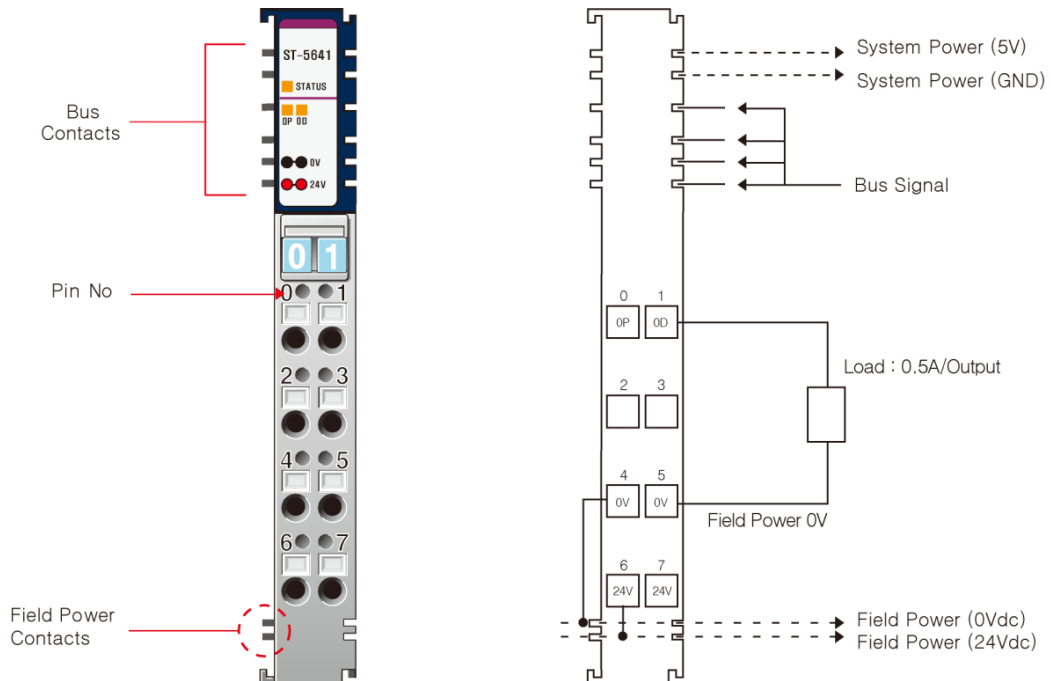

Figure 134: Pulse Output Module: ST-5641

The following table lists the pin numbers and description for ST-5641.

Table 203: ST-5641: Pin Description

<i>Pin Number</i>	<i>Description</i>	<i>Pin Number</i>	<i>Description</i>
0	Pulse Output Channel #0	1	Pulse Direction Output Channel #0
2	---	3	---
4	Field Power 0V, Common	5	Field Power 0V, Common
6	Field Power 24V	7	Field Power 24V

Specification

The following table describes the Output Specifications and the General Specifications for ST-5641.

Table 204: ST-5641: Output and General Specifications

Items	Specification
Output Specification	
Number of Channel	1 Channel, Positive Logic Type
Number of Output	2 Output/Channel 2 Output (1 Pulse Output, 1 Pulse Direction Output)
Indicators	1 Green/Red RSTi Bus Status 1 Pulse Output LED, 1 Pulse Direction Output LED
Output Current	0.5A/Output, 1A/All Output, short protection
Pulse Output Frequency	1~20,000Hz±0.5%
Pulse Output Duty	50%±3.0% Fixed, Ton>5us, Toff>5us
Pulse Output Quantity with One Command	Continuous Pulse Output Maximum +1~32767: Pulse Direction Output OFF Maximum -1~32767: Pulse Direction Output ON
Pulse Output Counter	Signed 32bit-wide
Diagnostic	Yes, Short Protection
Common Type	2 Common
General Specification	
Power Dissipation	Maximum 150mA @ 5.0Vdc
Isolation	I/O to Logic: Photo coupler isolation I/O to Field Power: Non-Isolation
Field Power	Supply Voltage: 24Vdc nominal Voltage Range: 18 ~ 28.8Vdc Power Dissipation: Maximum 50mA@24Vdc except Load
Wiring	I/O Cable Maximum 2.0mmim(AWG 14)
Weight	70g
Module Size	12mm x 99mm x 70mm
Environment Condition	See "Environmental Specifications" in Appendix A.

Dimension

The following illustration shows the dimension for ST-5641.

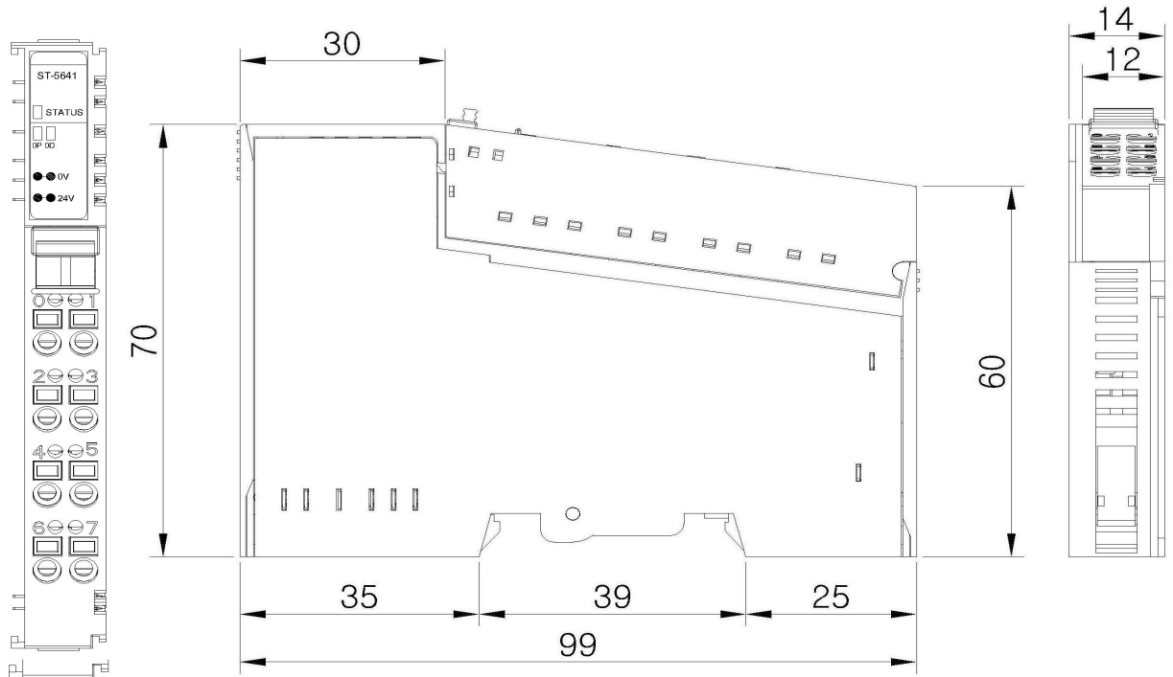

Figure 135: ST-5641 Dimension

Configuration and Operational Function

I/O Process Image Table

Input Image Data – 4 byte

Byte	Bit 7	Bit 6	Bit 5	Bit 4	Bit 3	Bit 2	Bit 1	Bit 0
0	Real Pulse Output Counter Ch#0 LL							
1	Real Pulse Output Counter Ch#0 LH							
2	Real Pulse Output Counter Ch#0 HL							
3	Real Pulse Output Counter Ch#0 HH							

Output Image Data – 6 byte

Byte	Bit 7	Bit 6	Bit 5	Bit 4	Bit 3	Bit 2	Bit 1	Bit 0
0	Pulse Frequency Ch#0 Low Byte							
1	Pulse Frequency Ch#0 High Byte							
2	Pulse Output Qty Ch#0 Low Byte							
3	Pulse Output Qty Ch#0 High Byte							
4	RUN0	ECP0	----	CLRCNT0	----	----	Frequency Multiple0	
5	----	----	----	----	----	----	----	----

- Pulse Output Qty is a signed 16bit-wide data.
- The duty of each channel frequency is fixed by 50%.
- If Pulse Output Qty \geq 0, Direction Output turns OFF. If Pulse Output Qty < 0, Direction Output turns ON.
- Byte 8 is a control for Channel #0.
- RUN0,1: Pulse Output Run
- ECP0, 1 (Enable Continuous Pulse): If this bit is '1' and Pulse Output Qty is not 0, pulse output always runs.
- CLRCNT0,1: Clear Real Pulse Output Counter

Frequency Multiple 0 Selection

Value	Description
0 (B'00)	x1 Frequency Multiple
1 (B'01)	x10 Frequency Multiple
2 (B'10)	x100 Frequency Multiple
3 (B'11)	x1000 Frequency Multiple

Configuration Parameter Data

Byte	Bit 7	Bit 6	Bit 5	Bit 4	Bit 3	Bit 2	Bit 1	Bit 0
0	Reserved							
1	Reserved							

ST-5642

Interface and Data

The following illustration shows the interface design for ST-5642.

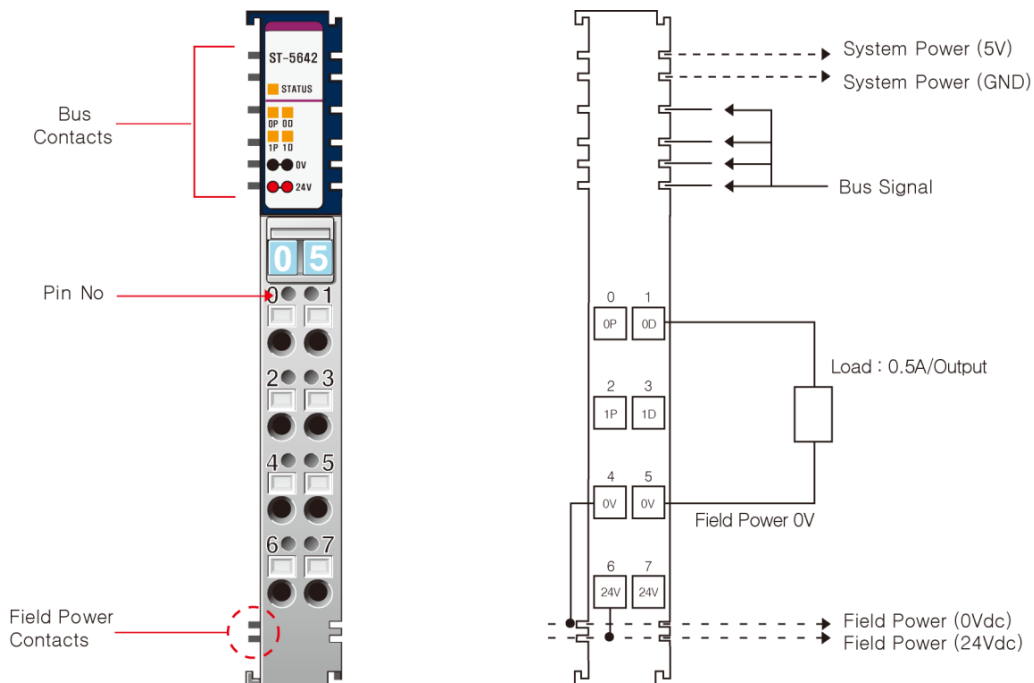

Figure 136: Pulse Output Module: ST-5642

The following table lists the pin numbers and description for ST-5642.

Table 205: ST-5642: Pin Description

Pin Number	Description	Pin Number	Description
0	Pulse Output Channel #0	1	Pulse Direction Output Channel #0
2	Pulse Output Channel #1	3	Pulse Direction Output Channel #1
4	Field Power 0V, Common	5	Field Power 0V, Common
6	Field Power 24V	7	Field Power 24V

Specification

The following table describes the Output Specifications and the General Specifications for ST-5642.

Table 206: ST-5642: Output and General Specifications

Items	Specification
Output Specification	
Number of Channel	2 Channel, Positive Logic Type
Number of Output	2 Output/Channel 4 Output (2 Pulse Output, 2 Pulse Direction Output)
Indicators	1 Green/Red RSTi Bus Status 2 Pulse Output LED, 2 Pulse Direction Output LED
Output Current	0.5A/Output, 2A/All Output, short protection
Pulse Output Frequency	1~20,000Hz±0.5%
Pulse Output Duty	50%±3.0% Fixed, Ton>5us, Toff>5us
Pulse Output Quantity with One Command	Continuous Pulse Output Maximum +1~32767 : Pulse Direction Output OFF Maximum -1~32767 : Pulse Direction Output ON
Pulse Output Counter	Signed 32bit-wide
Diagnostic	Yes, Short Protection
Common Type	2 Common
General Specification	
Power Dissipation	Maximum 150mA @ 5.0Vdc
Isolation	I/O to Logic: Photo coupler Isolation I/O to Field Power : Non-Isolation
Field Power	Supply Voltage: 24Vdc nominal Voltage Range: 18 ~28.8Vdc Power Dissipation: 60mA@24Vdc except Load
Wiring	I/O Cable Maximum 2.0mmim(AWG 14)
Weight	70g
Module Size	12mm x 99mm x 70mm
Environment Condition	See "Environmental Specifications" in Appendix A.

Dimension

The following illustration shows the dimension for ST-5642.

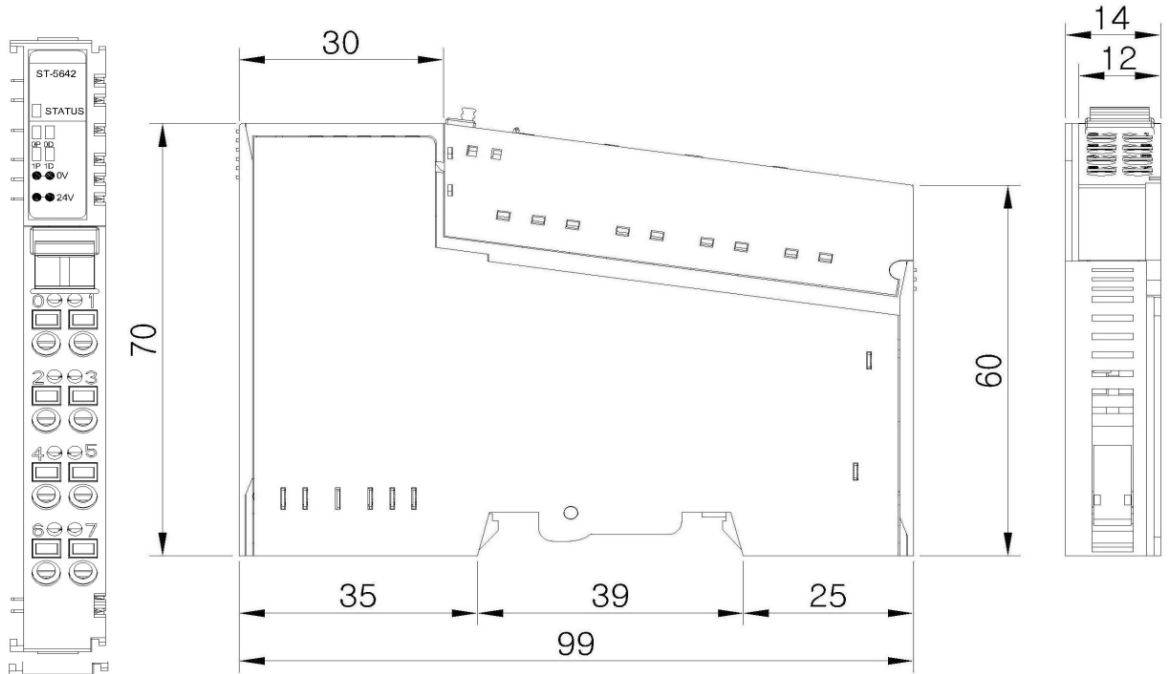

Figure 137: ST-5642 Dimension

Configuration and Operational Function

I/O Process Image Table

Input Image Data – 8byte

Byte	Bit 7	Bit 6	Bit 5	Bit 4	Bit 3	Bit 2	Bit 1	Bit 0
0	Real Pulse Output Counter Ch#0 LL							
1	Real Pulse Output Counter Ch#0 LH							
2	Real Pulse Output Counter Ch#0 HL							
3	Real Pulse Output Counter Ch#0 HH							
4	Real Pulse Output Counter Ch#1 LL							
5	Real Pulse Output Counter Ch#1 LH							
6	Real Pulse Output Counter Ch#1 HL							
7	Real Pulse Output Counter Ch#1 HH							

Output Image Data – 10 byte

Byte	Bit 7	Bit 6	Bit 5	Bit 4	Bit 3	Bit 2	Bit 1	Bit 0
0	Pulse Frequency Ch#0 Low Byte							
1	Pulse Frequency Ch#0 High Byte							
2	Pulse Output Qty Ch#0 Low Byte							
3	Pulse Output Qty Ch#0 High Byte							
4	Pulse Frequency Ch#0 Low Byte							
5	Pulse Frequency Ch#0 High Byte							
6	Pulse Output Qty Ch#0 Low Byte							
7	Pulse Output Qty Ch#0 High Byte							
8	RUN0	ECP0	----	CLRCNT0	----	----	Frequency Multiple0	
9	RUN0	ECP0	----	CLRCNT0	----	----	Frequency Multiple1	

- Pulse Output Qty is a signed 16bit-wide data.
- The duty of each channel frequency is fixed by 50%.
- If Pulse Output Qty ≥ 0, Direction Output turns OFF. If Pulse Output Qty < 0, Direction Output turns ON.
- Byte 8 is a control for Channel #0; Byte 9 is a control for Channel #1.
- RUN0,1: Pulse Output Run
- ECP0, 1 (Enable Continuous Pulse): If this bit is '1' and Pulse Output Qty is not 0, pulse output always runs.
- CLRCNT0,1: Clear Real Pulse Output Counter

Frequency Multiple 0 Selection

Value	Description
0 (B'00)	x1 Frequency Multiple
1 (B'01)	x10 Frequency Multiple
2 (B'10)	x100 Frequency Multiple
3 (B'11)	x1000 Frequency Multiple

- If Pulse Frequency=123 and Frequency Multiple=2, real pulse output is 12.3KHz (123*100)

Configuration Parameter Data

Byte	Bit 7	Bit 6	Bit 5	Bit 4	Bit 3	Bit 2	Bit 1	Bit 0
0	Reserved							
1	Reserved							

ST-5651

Interface and Data

The following illustration shows the interface design for ST-5651.

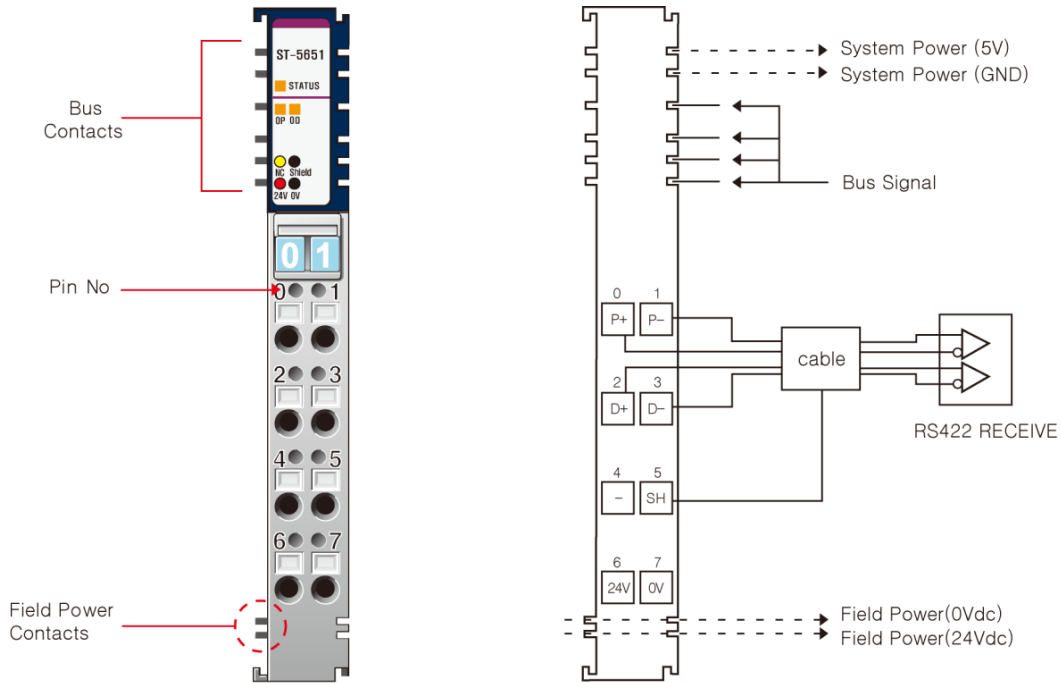

Figure 138: Pulse Output Module: ST-5651

The following table lists the pin numbers and description for ST-5651.

Table 207: ST-5651: Pin Description

Pin Number	Description	Pin Number	Description
0	Pulse+ (RS422 Differential Output)	1	Pulse- (RS422 Differential Output)
2	Direction+ (RS422 Differential Output)	3	Direction- (RS422 Differential Output)
4	----	5	Shield
6	Field Power 24V	7	Field Power 0V, Common

Specification

The following table describes the Output Specifications and the General Specifications for ST-5651.

Table 208: ST-5651: Output and General Specifications

Items	Specification
Output Specification	
Number of Channel	1 Channel, RS422 Differential Output
Number of Output	2 Output (1 Pulse Output, 1 Pulse Direction Output)
Indicators	1 Green/Red RSTi Bus Status 1 Pulse Output LED, 1 Pulse Direction Output LED
Pulse Output Frequency	5~200,000Hz±1.0%
Pulse Output Duty	50%±0.1% Fixed, Ton>10us, Toff>10us
Pulse Output Quantity with One Command	Continuous Pulse Output Maximum +1~32767: Pulse Direction Output OFF Maximum -1~32767: Pulse Direction Output ON
Pulse Output Counter	Signed 32bit-wide
Common Type	1 Common, 1 Shield
General Specification	
Power Dissipation	Maximum 150mA @ 5.0Vdc
Isolation	I/O to Logic : Photo coupler Isolation I/O to Field Power: Non-Isolation
Field Power	Supply Voltage: 24Vdc nominal Voltage Range: 11~28.8Vdc Power Dissipation: Maximum 40mA @24Vdc
Wiring	I/O Cable Maximum 2.0mm minimumle ipa
Weight	70g
Module Size	12mm x 99mm x 70mm
Environment Condition	See "Environmental Specifications" in Appendix A.

Dimension

The following illustration shows the dimension for ST-5651.

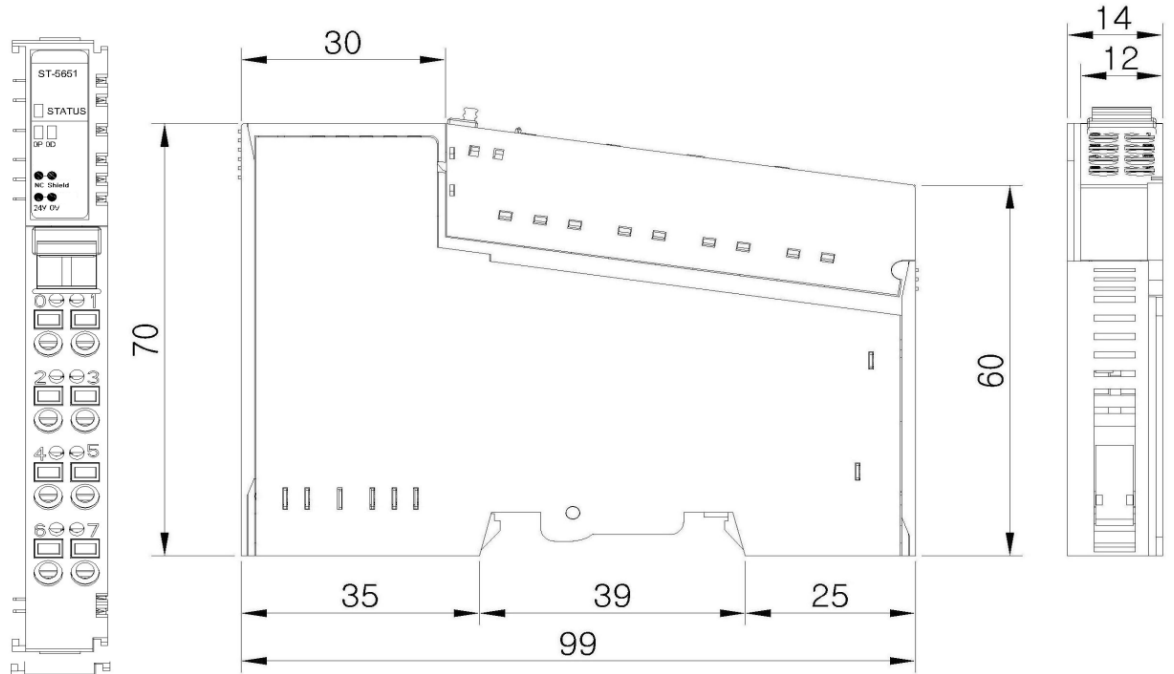

Figure 139: ST-5651 Dimension

Configuration and Operational Function

I/O Process Image Table

Input Image Data – 4 byte

Byte	Bit 7	Bit 6	Bit 5	Bit 4	Bit 3	Bit 2	Bit 1	Bit 0
0	Real Pulse Output Counter Ch#0 LL							
1	Real Pulse Output Counter Ch#0 LH							
2	Real Pulse Output Counter Ch#0 HL							
3	Real Pulse Output Counter Ch#0 HH							

- A Pulse Output Counter is a signed 32bit-wide data.

Output Image Data – 6 byte

Byte	Bit 7	Bit 6	Bit 5	Bit 4	Bit 3	Bit 2	Bit 1	Bit 0
0	Pulse Frequency Ch#0 Low Byte							
1	Pulse Frequency Ch#0 High Byte							
2	Pulse Output Qty Ch#0 Low Byte							
3	Pulse Output Qty Ch#0 High Byte							
8	RUN0	ECP0	----	CLRCNT0	----	----	Frequency Multiple0	
9	RUN0	ECP0	----	CLRCNT0	----	----		

- Pulse Output Qty is a signed 16bit-wide data.
- The duty of each channel frequency is fixed by 50%.
- If Pulse Output Qty \geq 0, Direction Output turns OFF. If Pulse Output Qty < 0, Direction Output turns ON.
- Byte 8 is a control for Channel #0.
- RUN0,1: Pulse Output Run
- ECP0, 1 (Enable Continuous Pulse): If this bit is '1' and Pulse Output Qty is not 0, pulse output always runs.
- CLRCNT0,1: Clear Real Pulse Output Counter

Frequency Multiple 0 Selection

Value	Description
0 (B'00)	x1 Frequency Multiple
1 (B'01)	x10 Frequency Multiple
2 (B'10)	x100 Frequency Multiple
3 (B'11)	x1000 Frequency Multiple

- If Pulse Frequency=123 and Frequency Multiple=2, real pulse output is 12.3KHz (123*100)

Configuration Parameter Data

Byte	Bit 7	Bit 6	Bit 5	Bit 4	Bit 3	Bit 2	Bit 1	Bit 0
0	Reserved							
1	Reserved							

Diagnostics

LED Indicator for High Speed Counter

The LEDs indicate the status of the module. The table below shows the corresponding functions of LEDs during normal operation. You can use this table as a reference for troubleshooting errors.

Note: For more help on troubleshooting errors related to Network Adaptor and its protocols, please refer to Network Adaptor User Manual.

Table 209: LED Indicator for High Speed Counter

Color	Status	Action
Off	<ul style="list-style-type: none"> – No Power – System power is not supplied 	<ul style="list-style-type: none"> – Check main power Cable – Contact sales team and send module for repair
Red	<ul style="list-style-type: none"> – Excess of expansion slot – Excess of IO size – Wrong IO composition – Occurrence of EEPROM checksum error 	<ul style="list-style-type: none"> – Use expansion slot up to 32. – Compose that IO total size is not excess. – Check composition I/O Module
Input/output LED does not operate	<ul style="list-style-type: none"> – Failure of initialize expansion model – Failure of RSTi Bus communication – Do not send any order 	<ul style="list-style-type: none"> – Check connector status both RSTi series and expansion module. – Check system configuration

LED Indicator for PWM, Pulse and Serial Module

The following table describes the LED indicators for PWM, Pulse and Serial Module.

Table 210: LED Indicator for PWM_Pulse Module and Serial Module

Color	Status	Action
Off	<ul style="list-style-type: none"> – No Power – System power is not supplied 	<ul style="list-style-type: none"> – Check main power Cable – Contact sales team and send module for repair
Red	<ul style="list-style-type: none"> – Excess of expansion slot – Excess of IO size – Wrong IO composition – Occurrence of EEPROM checksum error 	<ul style="list-style-type: none"> – Use expansion slot up to 32. – Compose that IO total size is not excess. – Check composition I/O Module

Accessories include End-Modules for the last slot of each Node. The Numbering for individual Number of Slots are also provided.

This chapter provides details on the following Accessories:

- STXACC001 Numbering, 0~9, White, 100EA
- STXACC002 Numbering, Blank, 100EA
- STXACC004 End Module, 7pcs
- STXRTB009 Removable Terminal Block, 9pcs
- STXRTB109 Removable Terminal Block, 9pcs for STXxxx Network Interface Modules except STXDNSxxx, ST-7x11
- STXRTB209 Removable Terminal Block, 9pcs for STXDNSxxx and ST-7x41

This chapter enlists the Configuration Parameters and Memory Register of all RSTi modules.

Note: The Parameter and Configuration Memory Register are not accessible with STXPNS001.

Configuration Parameter

Power Module

ST-7008 (Shield Module)

- Valid Parameter length: 0 byte
- Parameter Data: All of Parameter Data is not used.

ST-7108 (Common, 0Vdc)

- Valid Parameter length: 0 byte
- Parameter Data: All of Parameter Data is not used.

ST-7111 (Expansion Power Supply, Input 24Vdc, Output 1.0A/5Vdc)

- Valid Parameter length: 0 byte
- Parameter Data: All of Parameter Data is not used.

ST-7118 (Common, 24Vdc)

- Valid Parameter length: 0 byte
- Parameter Data: All of Parameter Data is not used.

ST-7188 (Common, 24Vdc/0Vdc)

- Valid Parameter length: 0 byte
- Parameter Data: All of Parameter Data is not used.

ST-7241 (Field Distributor, 5Vdc/24Vdc/48Vdc/110Vac/240Vac)

- Valid Parameter length: 0 byte
- Parameter Data: All of Parameter Data is not used.

ST-7408 (Shield Module, ID Type)

- Valid Parameter length: 0 byte
- Parameter Data: All of Parameter Data is not used.

ST-7508 (Common, 0Vdc, ID Type)

- Valid Parameter length: 0 byte
- Parameter Data: All of Parameter Data is not used.

ST-7511 (Expansion Power Supply, Input 24Vdc, Output 1.0A/5Vdc, ID Type)

- Valid Parameter length: 0 byte
- Parameter Data: All of Parameter Data is not used.

ST-7518 (Common, 24Vdc, ID Type)

- Valid Parameter length: 0 byte
- Parameter Data: All of Parameter Data is not used.

ST-7588 (Common, 24Vdc/0Vdc, ID Type)

- Valid Parameter length: 0 byte
- Parameter Data: All of Parameter Data is not used.

ST-7641 (Field Distributor, 5Vdc/24Vdc/48Vdc/110Vac/240Vac, ID Type)

- Valid Parameter length: 0 byte
- Parameter Data: All of Parameter Data is not used.

Discrete Input Module

ST-1114 (4-Positive Logic input, 5Vdc)

- Valid Parameter length: 0 byte
- Parameter Data: All of Parameter Data is not used.

ST-1124 (4-Negative Logic input, 5Vdc)

- Valid Parameter length: 0 byte
- Parameter Data: All of Parameter Data is not used.

ST-1214 (4- Positive Logic input, 24Vdc)

- Valid Parameter length: 0 byte
- Parameter Data: All of Parameter Data is not used.

ST-1224 (4- Negative Logic input, 24Vdc)

- Valid Parameter length: 0 byte
- Parameter Data: All of Parameter Data is not used.

ST-1314 (4- Positive Logic input, 48Vdc)

- Valid Parameter length: 0 byte
- Parameter Data: All of Parameter Data is not used.

ST-1324 (4- Negative Logic input, 48Vdc)

- Valid Parameter length: 0 byte
- Parameter Data: All of Parameter Data is not used.

ST-131F (16- Positive Logic input, 48Vdc)

- Valid Parameter length: 0 byte
- Parameter Data: All of Parameter Data is not used.

ST-1218 (8- Positive Logic input, 24Vdc)

- Valid Parameter length: 0 byte
- Parameter Data: All of Parameter Data is not used.

ST-1228 (8- Negative Logic input, 24Vdc)

- Valid Parameter length: 0 byte
- Parameter Data: All of Parameter Data is not used.

ST-121F (16- Positive Logic input, 24Vdc)

- Valid Parameter length: 0 byte
- Parameter Data: All of Parameter Data is not used.

ST-122F (16- Negative Logic input, 24Vdc)

- Valid Parameter length: 0 byte
- Parameter Data: All of Parameter Data is not used

ST-1804 (4-ac input, 110Vac)

- Valid Parameter length: 0 byte
- Parameter Data: All of Parameter Data is not used.

ST-1904 (4-ac input, 240Vac)

- Valid Parameter length: 0 byte
- Parameter Data: All of Parameter Data is not used

Discrete Output Module

ST-2114 (4-TTL Inverting (Positive Logic) output, 5Vdc 20mA)

- Valid Parameter length: 2 bytes
- Parameter Data:

Offset	Decimal Bit	Description	Default Value
0	00-03	Fault Action (0~3) 0: Fault Value, 1: Hold last state	0 (Fault Value)
	04-07	Reserved	0
1	00-03	Fault Value (0~3) 0: off, 1: on	0 (off)
	04-07	Reserved	0
2	00-07	Not used	0
3	00-07	Not used	0
4	00-07	Not used	0
5	00-07	Not used	0
6	00-07	Not used	0
7	00-07	Not used	0

† All values are stored in Adapter's EEPROM.

ST-2124 (4-TTL Non-Inverting (Positive Logic) output, 5Vdc 20mA)

- Valid Parameter length: 2 bytes
- Parameter Data:

Offset	Decimal Bit	Description	Default Value
0	00-03	Fault Action (0~3) 0: Fault Value, 1: Hold last state	0 (Fault Value)
	04-07	Reserved	0
1	00-03	Fault Value (0~3) 0: off, 1: on	0 (off)
	04-07	Reserved	0
2	00-07	Not used	0
3	00-07	Not used	0
4	00-07	Not used	0
5	00-07	Not used	0
6	00-07	Not used	0
7	00-07	Not used	0

† All values are stored in Adapter's EEPROM.

ST-2314 (4-Negative Logic output, 24Vdc 0.5A)

- Valid Parameter length: 2 bytes
- Parameter Data:

Offset	Decimal Bit	Description	Default Value
0	00-03	Fault Action (0~3) 0: Fault Value, 1: Hold last state	0 (Fault Value)
	04-07	Reserved	0
1	00-03	Fault Value (0~3) 0: off, 1: on	0 (off)
	04-07	Reserved	0
2	00-07	Not used	0
3	00-07	Not used	0
4	00-07	Not used	0
5	00-07	Not used	0
6	00-07	Not used	0
7	00-07	Not used	0

† All values are stored in Adapter's EEPROM.

ST-2324 (4- Positive Logic output, 24Vdc 0.5A)

- Valid Parameter length: 2 bytes
- Parameter Data:

Offset	Decimal Bit	Description	Default Value
0	00-03	Fault Action (0~3) 0: Fault Value, 1: Hold last state	0 (Fault Value)
	04-07	Reserved	0
1	00-03	Fault Value (0~3) 0: off, 1: on	0 (off)
	04-07	Reserved	0
2	00-07	Not used	0
3	00-07	Not used	0
4	00-07	Not used	0
5	00-07	Not used	0
6	00-07	Not used	0
7	00-07	Not used	0

† All values are stored in Adapter's EEPROM.

ST-2414 (4- Negative Logic output, Diagnostics, 24Vdc 0.5A)

- Valid Parameter length: 2 bytes
- Parameter Data:

Offset	Decimal Bit	Description	Default Value
0	00-03	Fault Action (0~3) 0: Fault Value, 1: Hold last state	0 (Fault Value)
	04-07	Reserved	0
1	00-03	Fault Value (0~3) 0: off, 1: on	0 (off)
	04-07	Reserved	0
2	00-07	Not used	0
3	00-07	Not used	0
4	00-07	Not used	0
5	00-07	Not used	0
6	00-07	Not used	0
7	00-07	Not used	0

† All values are stored in Adapter's EEPROM.

ST-2424 (4- Positive Logic output, Diagnostics, 24Vdc 0.5A)

- Valid Parameter length: 2 bytes
- Parameter Data:

Offset	Decimal Bit	Description	Default Value
0	00-03	Fault Action (0~3) 0: Fault Value, 1: Hold last state	0 (Fault Value)
	04-07	Reserved	0
1	00-03	Fault Value (0~3) 0: off, 1: on	0 (off)
	04-07	Reserved	0
2	00-07	Not used	0
3	00-07	Not used	0
4	00-07	Not used	0
5	00-07	Not used	0
6	00-07	Not used	0
7	00-07	Not used	0

† All values are stored in Adapter's EEPROM.

ST-2514 (4- Negative Logic output, Diagnostics, 24Vdc 2A)

- Valid Parameter length: 2 bytes
- Parameter Data:

Offset	Decimal Bit	Description	Default Value
0	00-03	Fault Action (0~3) 0: Fault Value, 1: Hold last state	0 (Fault Value)
	04-07	Reserved	0
1	00-03	Fault Value (0~3) 0: off, 1: on	0 (off)
	04-07	Reserved	0
2	00-07	Not used	0
3	00-07	Not used	0
4	00-07	Not used	0
5	00-07	Not used	0
6	00-07	Not used	0
7	00-07	Not used	0

† All values are stored in Adapter's EEPROM.

ST-2524 (4- Positive Logic output, Diagnostics, 24Vdc 2A)

- Valid Parameter length: 2 bytes
- Parameter Data:

Offset	Decimal Bit	Description	Default Value
0	00-03	Fault Action 0~3) 0: Fault Value, 1: Hold last state	0 (Fault Value)
	04-07	Reserved	0
1	00-03	Fault Value (0~3) 0: off, 1: on	0 (off)
	04-07	Reserved	0
2	00-07	Not used	0
3	00-07	Not used	0
4	00-07	Not used	0
5	00-07	Not used	0
6	00-07	Not used	0
7	00-07	Not used	0

† All values are stored in Adapter's EEPROM.

ST-2318 (8- Negative Logic output, 24Vdc 0.5A)

- Valid Parameter length: 2 bytes
- Parameter Data:

Offset	Decimal Bit	Description	Default Value
0	00-07	Fault Action (0~7) 0: Fault Value, 1: Hold last state	0 (Fault Value)
1	00-07	Fault Value (0~7) 0: off, 1: on	0 (off)
2	00-07	Not used	0
3	00-07	Not used	0
4	00-07	Not used	0
5	00-07	Not used	0
6	00-07	Not used	0
7	00-07	Not used	0

† All values are stored in Adapter's EEPROM.

ST-2328 (8- Positive Logic output, 24Vdc 0.5A)

- Valid Parameter length: 2 bytes
- Parameter Data:

Offset	Decimal Bit	Description	Default Value
0	00-07	Fault Action (0~7) 0: Fault Value, 1: Hold last state	0 (Fault Value)
1	00-07	Fault Value (0~7) 0: off, 1: on	0 (off)
2	00-07	Not used	0
3	00-07	Not used	0
4	00-07	Not used	0
5	00-07	Not used	0
6	00-07	Not used	0
7	00-07	Not used	0

† All values are stored in Adapter's EEPROM.

ST-221F (16- Negative Logic output, 24Vdc 0.3A)

- Valid Parameter length: 4 bytes
- Parameter Data:

Offset	Decimal Bit	Description	Default Value
0	00-07	Fault Action (ch0~ch7) 0: Fault Value, 1: Hold last state	0 (Fault Value)
1	00-07	Fault Action (ch8~ch15) 0: Fault Value, 1: Hold last state	0 (Fault Value)
2	00-07	Fault Value (ch0~ch7) 0: off, 1: on	0 (off)
3	00-07	Fault Value (ch8~ch15) 0: off, 1: on	0 (off)
4	00-07	Not used	0
5	00-07	Not used	0
6	00-07	Not used	0
7	00-07	Not used	0

† All values are stored in Adapter's EEPROM.

ST-222F (16- Positive Logic output, 24Vdc 0.3A)

- Valid Parameter length: 4 bytes
- Parameter Data:

Offset	Decimal Bit	Description	Default Value
0	00-07	Fault Action (ch0~ch7) 0: Fault Value, 1: Hold last state	0 (Fault Value)
1	00-07	Fault Action (ch8~ch15) 0: Fault Value, 1: Hold last state	0 (Fault Value)
2	00-07	Fault Value (ch0~ch7) 0: off, 1: on	0 (off)
3	00-07	Fault Value (ch8~ch15) 0: off, 1: on	0 (off)
4	00-07	Not used	0
5	00-07	Not used	0
6	00-07	Not used	0
7	00-07	Not used	0

† All values are stored in Adapter's EEPROM.

ST-2742 (2-relay output, 240Vac 2A)

- Valid Parameter length: 2 bytes
- Parameter Data:

Offset	Decimal Bit	Description	Default Value
0	00, 01	Fault Action (ch0, ch1) 0: Fault Value, 1: Hold last state	0 (Fault Value)
	02-07	Reserved	0
1	00, 01	Fault Value (ch0, ch1) 0: off, 1: on	0 (off)
	02-07	Reserved	0
2	00-07	Not used	0
3	00-07	Not used	0
4	00-07	Not used	0
5	00-07	Not used	0
6	00-07	Not used	0
7	00-07	Not used	0

† All values are stored in Adapter's EEPROM.

ST-2744 (4-relay output, 240Vac 2A)

- Valid Parameter length: 2 bytes
- Parameter Data:

Offset	Decimal Bit	Description	Default Value
0	00-03	Fault Action (ch0~ch3) 0: Fault Value, 1: Hold last state	0 (Fault Value)
	04-07	Reserved	0
1	00-03	Fault Value (ch0~ch3) 0: off, 1: on	0 (off)
	04-07	Reserved	0
2	00-07	Not used	0
3	00-07	Not used	0
4	00-07	Not used	0
5	00-07	Not used	0
6	00-07	Not used	0
7	00-07	Not used	0

† All values are stored in Adapter's EEPROM.

ST-2748 (8-relay output, 240Vac 2A)

- Valid Parameter length: 2 bytes
- Parameter Data:

Offset	Decimal Bit	Description	Default Value
0	00-07	Fault Action (ch0~ch7) 0: Fault Value, 1: Hold last state	0 (Fault Value)
1	00-07	Fault Value (ch0~ch7) 0: off, 1: on	0 (off)
2	00-07	Not used	0
3	00-07	Not used	0
4	00-07	Not used	0
5	00-07	Not used	0
6	00-07	Not used	0
7	00-07	Not used	0

† All values are stored in Adapter's EEPROM.

ST-2852 (2-triac output, 120Vac 0.5A)

- Valid Parameter length: 2 bytes
- Parameter Data:

Offset	Decimal Bit	Description	Default Value
0	00, 01	Fault Action (ch0, ch1) 0: Fault Value, 1: Hold last state	0 (Fault Value)
	02-07	Reserved	0
1	00, 01	Fault Value (ch0, ch1) 0: off, 1: on	0 (off)
	02-07	Reserved	0
2	00-07	Not used	0
3	00-07	Not used	0
4	00-07	Not used	0
5	00-07	Not used	0
6	00-07	Not used	0
7	00-07	Not used	0

† All values are stored in Adapter's EEPROM.

Analog Input Module

ST-3114 (4-current analog input, 0~20mA, 12bit)

- Valid Parameter length: 0 byte
- Parameter Data: All of Parameter Data is not used.

ST-3118 (8-current analog input, 0~20mA, 12bit)

- Valid Parameter length: 2 bytes
- Parameter Data:

Offset	Decimal Bit	Description	Default Value
0	00-07	Reserved	0
1	00-07	Reserved	0
2	00-07	Not used	0
3	00-07	Not used	0
4	00-07	Not used	0
5	00-07	Not used	0
6	00-07	Not used	0
7	00-07	Not used	0

† All values are stored in Adapter's EEPROM.

ST-3134 (4-current analog input, 0~20mA, 14bit)

- Valid Parameter length: 0 byte
- Parameter Data: All of Parameter Data is not used.

ST-3214 (4-current analog input, 4~20mA, 12bit)

- Valid Parameter length: 0 byte
- Parameter Data: All of Parameter Data is not used.

ST-3218 (8-current analog input, 4~20mA, 12bit)

- Valid Parameter length: 2 bytes
- Parameter Data:

Offset	Decimal Bit	Description	Default Value
0	00-07	Reserved	0
1	00-07	Reserved	0
2	00-07	Not used	0
3	00-07	Not used	0
4	00-07	Not used	0
5	00-07	Not used	0
6	00-07	Not used	0
7	00-07	Not used	0

† All values are stored in Adapter's EEPROM.

ST-3234 (4-current analog input, 4~20mA, 14bit)

- Valid Parameter length: 0 byte
- Parameter Data: All of Parameter Data is not used.

ST-3424 (4-voltage analog input, 0~10V, 12bit)

- Valid Parameter length: 0 byte
- Parameter Data: All of Parameter Data is not used.

ST-3428 (8-voltage analog input, 0~10V, 12bit)

- Valid Parameter length: 2 bytes
- Parameter Data:

<i>Offset</i>	<i>Decimal Bit</i>	<i>Description</i>	<i>Default Value</i>
0	00-07	Reserved	0
1	00-07	Reserved	0
2	00-07	Not used	0
3	00-07	Not used	0
4	00-07	Not used	0
5	00-07	Not used	0
6	00-07	Not used	0
7	00-07	Not used	0

† All values are stored in Adapter's EEPROM.

ST-3444 (4-voltage analog input, 0~10V, 14bit)

- Valid Parameter length: 0 byte
- Parameter Data: All of Parameter Data is not used.

ST-3524 (4-voltage analog input, -10~10V, 12bit)

- Valid Parameter length: 0 byte
- Parameter Data: All of Parameter Data is not used.

ST-3544 (4-voltage analog input, -10~10V, 14bit)

- Valid Parameter length: 0 byte
- Parameter Data: All of Parameter Data is not used.

ST-3624 (4-voltage analog input, 0~5V, 12bit)

- Valid Parameter length: 0 byte
- Parameter Data: All of Parameter Data is not used.

ST-3644 (4-voltage analog input, 0~5V, 14bit)

- Valid Parameter length: 0 byte
- Parameter Data: All of Parameter Data is not used.

ST-3702 (2- RTD/Resistance input)

- Valid Parameter length: 2 bytes
- Parameter Data:

Offset	Decimal Bit	Description	Default Value
0	00-07	The selection Sensor Type =00h:PT100, 0.00385, -200~850°C, 0.1°C/count =01h:PT200, 0.00385, -200~850°C, 0.1°C/count =02h:PT500, 0.00385, -200~850°C, 0.1°C/count =03h:PT1000, 0.00385, -200~350°C, 0.1°C/count =04h:PT50, 0.00385, -200~850°C, 0.1°C/count =10h:JPT100, 0.003916, -200~640°C, 0.1°C/count =11h:JPT200, 0.003916, -200~640°C, 0.1°C/count =12h:JPT500, 0.003916, -200~640°C, 0.1°C/count =13h:JPT1000, 0.003916, -200~350°C, 0.1°C/count =20h:NI100, 0.00618, -60~250°C, 0.1°C/count =21h:NI200, 0.00618, -60~250°C, 0.1°C/count =22h:NI500, 0.00618, -60~250°C, 0.1°C/count =23h:NI1000, 0.00618, -60~180°C, 0.1°C/count =30h:NI120, 0.00672, -80~250°C, 0.1°C/count =40h:CU10, 0.00427, -200~260°C, 0.1°C/count =80h:Resistance Input, 1~2000Ω, 100mΩ/1count =81h: Resistance Input, 1~327Ω, 10mΩ/1count =82h: Resistance Input, 1~620Ω, 20mΩ/1count =Others: Reserved	0: PT100
1	00	Temperature Type 0: Celsius (°C), 1: Fahrenheit (°F)	0: Celsius (°C)
	01	Reserved	0
	02	Data Resolution 0: 0.1°C, °F/bit, 1: 1°C, °F/bit	0
	03	Reserved	0
	04	Filter Type 0: Normal Filter, 1: Enhanced Filter	0: Normal Filter
	05-07	Reserved	0
2	00-07	Not used	0
3	00-07	Not used	0
4	00-07	Not used	0
5	00-07	Not used	0
6	00-07	Not used	0
7	00-07	Not used	0

† All values are stored in Adapter's EEPROM.

ST-3704 (4- RTD/Resistance input)

- Valid Parameter length: 2 bytes
- Parameter Data:

Offset	Decimal Bit	Description	Default Value
0	00-07	The selection Sensor Type =00h:PT100, 0.00385, -200~850°C, 0.1°C/count =01h:PT200, 0.00385, -200~850°C, 0.1°C/count =02h:PT500, 0.00385, -200~850°C, 0.1°C/count =03h:PT1000, 0.00385, -200~350°C, 0.1°C/count =04h:PT50, 0.00385, -200~850°C, 0.1°C/count =10h:JPT100, 0.003916, -200~640°C, 0.1°C/count =11h:JPT200, 0.003916, -200~640°C, 0.1°C/count =12h:JPT500, 0.003916, -200~640°C, 0.1°C/count =13h:JPT1000, 0.003916, -200~350°C, 0.1°C/count =20h:NI100, 0.00618, -60~250°C, 0.1°C/count =21h:NI200, 0.00618, -60~250°C, 0.1°C/count =22h:NI500, 0.00618, -60~250°C, 0.1°C/count =23h:NI1000, 0.00618, -60~180°C, 0.1°C/count =30h:NI120, 0.00672, -80~250°C, 0.1°C/count =40h:CU10, 0.00427, -200~260°C, 0.1°C/count =80h:Resistance Input, 1~2000Ω, 100mΩ/1count =81h: Resistance Input, 1~327Ω, 10mΩ/1count =82h: Resistance Input, 1~620Ω, 20mΩ/1count =Others: Reserved	0: PT100
1	00	Temperature Type 0: Celsius (°C), 1: Fahrenheit (°F)	0: Celsius (°C)
	01	Reserved	0
	02	Data Resolution 0: 0.1°C, °F/bit, 1: 1°C, °F/bit	0
	03	Reserved	0
	04	Filter Type 0: Normal Filter, 1: Enhanced Filter	0: Normal Filter
	05-07	Reserved	0
2	00-07	Not used	0
3	00-07	Not used	0
4	00-07	Not used	0
5	00-07	Not used	0
6	00-07	Not used	0
7	00-07	Not used	0

† All values are stored in Adapter's EEPROM.

ST-3708 (8- RTD/Resistance input)

- Valid Parameter length: 2 bytes
- Parameter Data:

Offset	Decimal Bit	Description	Default Value
0	00-07	The selection Sensor Type =00h:PT100, 0.00385, -200~850°C, 0.1°C/count =01h:PT200, 0.00385, -200~850°C, 0.1°C/count =02h:PT500, 0.00385, -200~850°C, 0.1°C/count =03h:PT1000, 0.00385, -200~350°C, 0.1°C/count =04h:PT50, 0.00385, -200~850°C, 0.1°C/count =10h:JPT100, 0.003916, -200~640°C, 0.1°C/count =11h:JPT200, 0.003916, -200~640°C, 0.1°C/count =12h:JPT500, 0.003916, -200~640°C, 0.1°C/count =13h:JPT1000, 0.003916, -200~350°C, 0.1°C/count =20h:NI100, 0.00618, -60~250°C, 0.1°C/count =21h:NI200, 0.00618, -60~250°C, 0.1°C/count =22h:NI500, 0.00618, -60~250°C, 0.1°C/count =23h:NI1000, 0.00618, -60~180°C, 0.1°C/count =30h:NI120, 0.00672, -80~250°C, 0.1°C/count =40h:CU10, 0.00427, -200~260°C, 0.1°C/count =80h:Resistance Input, 1~2000Ω, 100mΩ/1count =81h: Resistance Input, 1~327Ω, 10mΩ/1count =82h: Resistance Input, 1~620Ω, 20mΩ/1count =Others: Reserved	0: PT100
1	00	Temperature Type 0: Celsius (°C), 1: Fahrenheit (°F)	0: Celsius (°C)
	01	Reserved	0
	02	Data Resolution 0: 0.1°C, °F/bit, 1: 1°C, °F/bit	0
	03	Reserved	0
	04	Filter Type 0: Normal Filter, 1: Enhanced Filter	0: Normal Filter
	05-07	Reserved	0
2	00-07	Not used	0
3	00-07	Not used	0
4	00-07	Not used	0
5	00-07	Not used	0
6	00-07	Not used	0
7	00-07	Not used	0

† All values are stored in Adapter's EEPROM.

ST-3802 (2- Thermocouple/mV input)

- Valid Parameter length: 4 bytes
- Parameter Data:

Offset	Decimal Bit	Description	Default Value
0	00-07	The selection Sensor Type =00h:PT100, 0.00385, -200~850°C, 0.1°C/count =01h:PT200, 0.00385, -200~850°C, 0.1°C/count =02h:PT500, 0.00385, -200~850°C, 0.1°C/count =03h:PT1000, 0.00385, -200~350°C, 0.1°C/count =04h:PT50, 0.00385, -200~850°C, 0.1°C/count =10h:JPT100, 0.003916, -200~640°C, 0.1°C/count =11h:JPT200, 0.003916, -200~640°C, 0.1°C/count =12h:JPT500, 0.003916, -200~640°C, 0.1°C/count =13h:JPT1000, 0.003916, -200~350°C, 0.1°C/count =20h:NI100, 0.00618, -60~250°C, 0.1°C/count =21h:NI200, 0.00618, -60~250°C, 0.1°C/count =22h:NI500, 0.00618, -60~250°C, 0.1°C/count =23h:NI1000, 0.00618, -60~180°C, 0.1°C/count =30h:NI120, 0.00672, -80~250°C, 0.1°C/count =40h:CU10, 0.00427, -200~260°C, 0.1°C/count =80h:Resistance Input, 1~2000Ω, 100mΩ/1count =81h: Resistance Input, 1~327Ω, 10mΩ/1count =82h: Resistance Input, 1~620Ω, 20mΩ/1count =Others: Reserved	0: PT100
1	00	Temperature Type 0: Celsius (°C), 1: Fahrenheit (°F)	0: Celsius (°C)
	01	Reserved	0
	02	Data Resolution 0: 0.1°C, °F/bit, 1: 1°C, °F/bit	0
	03	Reserved	0
	04	Filter Type 0: Normal Filter, 1: Enhanced Filter	0: Normal Filter
	05-07	Reserved	0
2	00-07	Not used	0
3	00-07	Not used	0
4	00-07	Not used	0
5	00-07	Not used	0
6	00-07	Not used	0
7	00-07	Not used	0

† All values are stored in Adapter's EEPROM.

ST-3804 (4- Thermocouple/mV input)

- Valid Parameter length: 4 bytes
- Parameter Data:

Offset	Decimal Bit	Description	Default Value
0	00-07	The selection Sensor Type =00h: Type K, 0.1°C/count =01h: Type J, 0.1°C/count =02h: Type T, 0.1°C/count =03h: Type B, 0.1°C/count =04h: Type R, 0.1°C/count =05h: Type S, 0.1°C/count =06h: Type E, 0.1°C/count =07h: Type N, 0.1°C/count =08h: Type L, 0.1°C/count =09h: Type U, 0.1°C/count =0Ah: Type C, 0.1°C/count =0Bh: Type D, 0.1°C/count =80h: 10uV Input, -78.0~78.0mV, 10uV/count =81h: 1uV Input, -32.7~32.7mV, 1uV/count =82h: 2uV Input, -65.5~65.5mV, 2uV/count =Others: Reserved	0: Type K
1	00	Temperature Type 0: Celsius(°C), 1: Fahrenheit(°F)	0: Celsius(°C)
	01	0: Cold Junction Compensation 1: Disable Compensation	0
	02	Data Resolution 0: 0.1°C, °F/bit, 1: 1°C, °F/bit	0
	03	Reserved	
	04	Filter Type 0: Normal Filter, 1: Enhanced Filter	0: Normal Filter
	05-07	Reserved	0
2	00-07	Cold Junction Temperature Offset Data Low Byte	0
3	00-07	Cold Junction Temperature Offset Data High Byte	0
4	00-07	Not used	0
5	00-07	Not used	0
6	00-07	Not used	0
7	00-07	Not used	0

† All values are stored in Adapter's EEPROM.

ST-3808 (8- Thermocouple/mV input)

- Valid Parameter length: 4 bytes
- Parameter Data:

Offset	Decimal Bit	Description	Default Value
0	00-07	The selection Sensor Type =00h: Type K, 0.1°C/count =01h: Type J, 0.1°C/count =02h: Type T, 0.1°C/count =03h: Type B, 0.1°C/count =04h: Type R, 0.1°C/count =05h: Type S, 0.1°C/count =06h: Type E, 0.1°C/count =07h: Type N, 0.1°C/count =08h: Type L, 0.1°C/count =09h: Type U, 0.1°C/count =0Ah: Type C, 0.1°C/count =0Bh: Type D, 0.1°C/count =80h: 10uV Input, -78.0~78.0mV, 10uV/count =81h: 1uV Input, -32.7~32.7mV, 1uV/count =82h: 2uV Input, -65.5~65.5mV, 2uV/count =Others: Reserved	0: Type K
1	00	Temperature Type 0: Celsius(°C), 1: Fahrenheit(°F)	0: Celsius(°C)
	01	0: Cold Junction Compensation 1: Disable Compensation	0
	02	Data Resolution 0: 0.1°C, °F /bit, 1: 1°C, °F /bit	0
	03	Reserved	
	04	Filter Type 0: Normal Filter, 1: Enhanced Filter	0: Normal Filter
	05-07	Reserved	0
2	00-07	Cold Junction Temperature Offset Data Low Byte	0
3	00-07	Cold Junction Temperature Offset Data High Byte	0
4	00-07	Not used	0
5	00-07	Not used	0
6	00-07	Not used	0
7	00-07	Not used	0

† All values are stored in Adapter's EEPROM.

Analog Output Module

ST-4112 (2-current analog output, 0~20mA, 12bit)

- Valid Parameter length: 6 bytes
- Parameter Data:

Offset	Decimal Bit	Description	Default Value
0	00-01	Fault Action for channel 0 00: Fault Value, 01: Hold last state, 10: Low Limit, 11:High Limit	0 (Fault Value)
	02-03	Fault Action for channel 1 00: Fault Value, 01: Hold last state, 10: Low Limit, 11:High Limit	0 (Fault Value)
	04-07	Reserved	0
1	00-07	Reserved	0
2	00-07	Channel 0 Fault Value Low Byte	0
3	00-03	Channel 0 Fault Value High Byte	0
	04-07	Reserved	0
4	00-07	Channel 1 Fault Value Low Byte	0
5	00-03	Channel 1 Fault Value High Byte	0
	04-07	Reserved	0
6	00-07	Not used	0
7	00-07	Not used	0

† All values are stored in Adapter's EEPROM.

ST-4114 (4-current analog output, 0~20mA, 12bit)

- Valid Parameter length: 4 bytes
- Parameter Data:

Offset	Decimal Bit	Description	Default Value
0	00-01	Fault Action for channel 0 00: Fault Value, 01: Hold last state, 10: Low Limit, 11:High Limit	0 (Fault Value)
	02-03	Fault Action for channel 1 00: Fault Value, 01: Hold last state, 10: Low Limit, 11:High Limit	0 (Fault Value)
	04-05	Fault Action for channel 2 00: Fault Value, 01: Hold last state, 10: Low Limit, 11:High Limit	0 (Fault Value)
	06-07	Fault Action for channel 3 00: Fault Value, 01: Hold last state, 10: Low Limit, 11:High Limit	0 (Fault Value)
1	00-07	Reserved	0
2	00-07	Channel 0 Fault Value Low Byte	0
3	00-03	Channel 0 Fault Value High Byte	0
4	00-07	Not used	0
5	00-07	Not used	0
6	00-07	Not used	0
7	00-07	Not used	0

† All values are stored in Adapter's EEPROM.

ST-4212 (2-current analog output, 4~20mA, 12bit)

- Valid Parameter length: 6 bytes
- Parameter Data:

Offset	Decimal Bit	Description	Default Value
0	00-01	Fault Action for channel 0 00: Fault Value, 01: Hold last state, 10: Low Limit, 11: High Limit	0 (Fault Value)
	02-03	Fault Action for channel 1 00: Fault Value, 01: Hold last state, 10: Low Limit, 11: High Limit	0 (Fault Value)
	04-07	Reserved	0
1	00-07	Reserved	0
2	00-07	Channel 0 Fault Value Low Byte	0
3	00-03	Channel 0 Fault Value High Byte	0
	04-07	Reserved	0
4	00-07	Channel 1 Fault Value Low Byte	0
5	00-03	Channel 1 Fault Value High Byte	0
	04-07	Reserved	0
6	00-07	Not used	0
7	00-07	Not used	0

† All values are stored in Adapter's EEPROM.

ST-4214 (4-current analog output, 4~20mA, 12bit)

- Valid Parameter length: 4 bytes
- Parameter Data:

Offset	Decimal Bit	Description	Default Value
0	00-01	Fault Action for channel 0 00: Fault Value, 01: Hold last state, 10: Low Limit, 11: High Limit	0 (Fault Value)
	02-03	Fault Action for channel 1 00: Fault Value, 01: Hold last state, 10: Low Limit, 11:High Limit	0 (Fault Value)
	04-05	Fault Action for channel 2 00: Fault Value, 01: Hold last state, 10: Low Limit, 11:High Limit	0 (Fault Value)
	06-07	Fault Action for channel 3 00: Fault Value, 01: Hold last state, 10: Low Limit, 11:High Limit	0 (Fault Value)
1	00-07	Reserved	0
2	00-07	Channel 0 Fault Value Low Byte	0
3	00-03	Channel 0 Fault Value High Byte	0
4	00-07	Not used	0
5	00-07	Not used	0
6	00-07	Not used	0
7	00-07	Not used	0

† All values are stored in Adapter's EEPROM.

ST-4422 (2-voltage analog output, 0~10Vdc, 12bit)

- Valid Parameter length: 6 bytes
- Parameter Data:

Offset	Decimal Bit	Description	Default Value
0	00-01	Fault Action for channel 0 00: Fault Value, 01: Hold last state, 10: Low Limit, 11: High Limit	0 (Fault Value)
	02-03	Fault Action for channel 1 00: Fault Value, 01: Hold last state, 10: Low Limit, 11: High Limit	0 (Fault Value)
	04-07	Reserved	0
1	00-07	Reserved	0
2	00-07	Channel 0 Fault Value Low Byte	0
3	00-03	Channel 0 Fault Value High Byte	0
	04-07	Reserved	0
4	00-07	Channel 1 Fault Value Low Byte	0
5	00-03	Channel 1 Fault Value High Byte	0
	04-07	Reserved	0
6	00-07	Not used	0
7	00-07	Not used	0

† All values are stored in Adapter's EEPROM.

ST-4424 (4-voltage analog output, 0~10Vdc, 12bit)

- Valid Parameter length: 4 bytes
- Parameter Data:

<i>Offset</i>	<i>Decimal Bit</i>	<i>Description</i>	<i>Default Value</i>
0	00-01	Fault Action for channel 0 00: Fault Value, 01: Hold last state, 10: Low Limit, 11: High Limit	0 (Fault Value)
	02-03	Fault Action for channel 1 00: Fault Value, 01: Hold last state, 10: Low Limit, 11:High Limit	0 (Fault Value)
	04-05	Fault Action for channel 2 00: Fault Value, 01: Hold last state, 10: Low Limit, 11:High Limit	0 (Fault Value)
	06-07	Fault Action for channel 3 00: Fault Value, 01: Hold last state, 10: Low Limit, 11:High Limit	0 (Fault Value)
1	00-07	Reserved	0
2	00-07	Channel 0 Fault Value Low Byte	0
3	00-03	Channel 0 Fault Value High Byte	0
4	00-07	Not used	0
5	00-07	Not used	0
6	00-07	Not used	0
7	00-07	Not used	0

† All values are stored in Adapter's EEPROM.

ST-4474 (4-voltage analog output, 0~10Vdc, 12bit, Sensor Connector)

- Valid Parameter length: 4 bytes
- Parameter Data:

<i>Offset</i>	<i>Decimal Bit</i>	<i>Description</i>	<i>Default Value</i>
0	00-01	Fault Action for channel 0 00: Fault Value, 01: Hold last state, 10: Low Limit, 11: High Limit	0 (Fault Value)
	02-03	Fault Action for channel 1 00: Fault Value, 01: Hold last state, 10: Low Limit, 11: High Limit	0 (Fault Value)
	04-05	Fault Action for channel 2 00: Fault Value, 01: Hold last state, 10: Low Limit, 11: High Limit	0 (Fault Value)
	06-07	Fault Action for channel 3 00: Fault Value, 01: Hold last state, 10: Low Limit, 11: High Limit	0 (Fault Value)
1	00-07	Reserved	0
2	00-07	Channel 0~3 Fault Value Low Byte	0
3	00-07	Channel 0~3 Fault Value High Byte	0
4	00-07	Not used	0
5	00-07	Not used	0
6	00-07	Not used	0
7	00-07	Not used	0

† All values are stored in Adapter's EEPROM.

ST-4491 (1-voltage analog output, 0~10Vdc, 12bit, Manual Type)

- Valid Parameter length: 4 bytes
- Parameter Data:

ST-4522 (2-voltage analog output, -10~10Vdc, 12bit)

- Valid Parameter length: 6 bytes
- Parameter Data:

Offset	Decimal Bit	Description	Default Value
0	00-01	Fault Action for channel 0 00: Fault Value, 01: Hold last state, 10: Low Limit, 11: High Limit	0 (Fault Value)
	02-03	Fault Action for channel 1 00: Fault Value, 01: Hold last state, 10: Low Limit, 11: High Limit	0 (Fault Value)
	04-07	Reserved	0
1	00-07	Reserved	0
2	00-07	Channel 0 Fault Value Low Byte	0
3	00-03	Channel 0 Fault Value High Byte	0
	04-07	Reserved	0
4	00-07	Channel 1 Fault Value Low Byte	0
	00-03	Channel 1 Fault Value High Byte	0
5	04-07	Reserved	0
	00-07	Not used	0
7	00-07	Not used	0

† All values are stored in Adapter's EEPROM.

ST-4622 (2-voltage analog output, 0~5Vdc, 12bit)

- Valid Parameter length: 6 bytes
- Parameter Data:

Offset	Decimal Bit	Description	Default Value
0	00-01	Fault Action for channel 0 00: Fault Value, 01: Hold last state, 10: Low Limit, 11: High Limit	0 (Fault Value)
	02-03	Fault Action for channel 1 00: Fault Value, 01: Hold last state, 10: Low Limit, 11: High Limit	0 (Fault Value)
	04-07	Reserved	0
1	00-07	Reserved	0
2	00-07	Channel 0 Fault Value Low Byte	0
3	00-03	Channel 0 Fault Value High Byte	0
	04-07	Reserved	0
4	00-07	Channel 1 Fault Value Low Byte	0
5	00-03	Channel 1 Fault Value High Byte	0
	04-07	Reserved	0
6	00-07	Not used	0
7	00-07	Not used	0

† All values are stored in Adapter's EEPROM.

ST-4911 (1-current analog output, 0~1A, 12bit)

- Valid Parameter length: 6 bytes
- Parameter Data:

Offset	Decimal Bit	Description	Default Value
0	00-01	Fault Action for channel 0 00: Fault Value, 01: Hold last state, 10: Low Limit, 11: High Limit	0 (Fault Value)
	02-07	Reserved	0
1	00-07	Reserved	0
2	00-07	Channel 0 Fault Value Low Byte	0
3	00-03	Channel 0 Fault Value High Byte	0
	04-07	Reserved	0
4	00-07	Reserved	0
5	00-07	Reserved	0
6	00-07	Not used	0
7	00-07	Not used	0

Special Modules

ST-5101 (1 Channel High Speed Counter 5Vdc)

- Valid Parameter length: 2 bytes
- Parameter Data:

Offset	Decimal Bit	Description	Default Value
0	00-03	Counter Mode 0000: Counter Disabled 0101: Encoder x4 0001: 1Pulse Mode 0110: Period/Rate Mode 0010: 2Pulse Mode 0111: reserved 0011: Encoder x1 1000: PWM Output Mode 0100: Encoder x2 1001: reserved Others: Counter Disable	0
	04-07	Gate Function 0000: Gate Function Disabled 0011: Store-Reset/Wait/Start 0001: Store/Continue 0100: Store-Reset/Start 0010: Store/Wait/Resume Others: Gate Function Disabled	0
1	00-03	Input Filter 0000: Bypass(about 1.5MHz) 0101: 100usec (5KHz±30%) 0001: 1usec (500KHz±30%) 0110: 500usec (1KHz±30%) 0010: 5usec (100KHz±30%) 0111: 1msec (500Hz±30%) 0011: 10usec (50KHz±30%) 1000: 5msec (100Hz±30%) 0100: 50usec (10KHz±30%) 1001: 10msec (50Hz±30%) Others : Bypass(about 1.5MHz)	0
	04-07	Gate Sampling Time 0000: (10/1)MHz (0.1usec) 0100: (10/16)MHz (1.6usec) 0001: (10/2)MHz (0.2usec) 0101: (10/32)MHz (3.2usec) 0010: (10/4)MHz (0.4usec) 0110: (10/64)MHz (6.4usec) 0011: (10/8)MHz (0.8usec) 0111: (10/128)MHz (12.8usec) Others: (10/1)MHz (0.1usec)	0
2	00-07	Not used	0
3	00-07	Not used	0
4	00-07	Not used	0
5	00-07	Not used	0
6	00-07	Not used	0
7	00-07	Not used	0

† All values are stored in Adapter's EEPROM.

ST-5111 (1 Channel High Speed Counter 24Vdc)

- Valid Parameter length: 2 bytes
- Parameter Data:

Offset	Decimal Bit	Description	Default Value
0	00-03	Counter Mode 0000: Counter Disabled 0101: Encoder x4 0001: 1Pulse Mode 0110: Period/Rate Mode 0010: 2Pulse Mode 0111: reserved 0011: Encoder x1 1000: PWM Output Mode 0100: Encoder x2 1001: reserved Others: Counter Disable	0
	04-07	Gate Function 0000: Gate Function Disabled 0001: Store/Continue 0010: Store/Wait/Resume 0011: Store-Reset/Wait/Start 0100: Store-Reset/Start Others: Gate Function Disabled	0
1	00-03	Input Filter 0000 : Bypass(about 1.5MHz) 0101: 100usec (5KHz±30%) 0001: 1usec (500KHz±30%) 0110: 500usec (1KHz±30%) 0010: 5usec (100KHz±30%) 0111: 1msec (500Hz±30%) 0011: 10usec (50KHz±30%) 1000: 5msec (100Hz±30%) 0100: 50usec (10KHz±30%) 1001: 10msec (50Hz±30%) Others : Bypass(about 1.5MHz)	0
	04-07	Gate Sampling Time 0000: (10/1)MHz (0.1usec) 0100: (10/16)MHz (1.6usec) 0001: (10/2)MHz (0.2usec) 0101: (10/32)MHz (3.2usec) 0010: (10/4)MHz (0.4usec) 0110: (10/64)MHz (6.4usec) 0011: (10/8)MHz (0.8usec) 0111: (10/128)MHz (12.8usec) Others: (10/1)MHz (0.1usec)	0
2	00-07	Not used	0
3	00-07	Not used	0
4	00-07	Not used	0
5	00-07	Not used	0
6	00-07	Not used	0
7	00-07	Not used	0

† All values are stored in Adapter's EEPROM.

ST-5112 (2 Channel High Speed Counter 24Vdc)

- Valid Parameter length: 4 bytes
- Parameter Data:

Offset	Decimal Bit	Description	Default Value
0	00-07	Reserved	0
1	00-07	Reserved	0
2	00-07	Reserved	0
3	00-07	Reserved	0
4	00-07	Not used	0
5	00-07	Not used	0
6	00-07	Not used	0
7	00-07	Not used	0

† All values are stored in Adapter's EEPROM.

ST-5114 (4 Channel High Speed Counter 24Vdc)

- Valid Parameter length: 4 bytes
- Parameter Data:

<i>Offset</i>	<i>Decimal Bit</i>	<i>Description</i>	<i>Default Value</i>
0	00-07	Reserved	0
1	00-07	Reserved	0
2	00-07	Reserved	0
3	00-07	Reserved	0
4	00-07	Not used	0
5	00-07	Not used	0
6	00-07	Not used	0
7	00-07	Not used	0

† All values are stored in Adapter's EEPROM.

ST-5211 (1 Channel Serial Interface RS-232)

- Valid Parameter length: 4 bytes
- Parameter Data:

<i>Offset</i>	<i>Decimal Bit</i>	<i>Description</i>	<i>Default Value</i>
0	00-03	Baud Rate 0000: 300bps 0101: 19200bps 0001: 1200bps 0110: 38400bps 0010: 2400bps 0111: 57600bps 0011: 4800bps 1000: 115200bps 0100: 9600bps Others: Unused	0100
	04-05	Data Bit 00: 7 Data bit 10: 9 Data bit 01: 8 Data bit Others: Unused	01
	06-07	Parity Bit 00: No Parity 10: Even Parity 01: Odd Parity Others: Unused	00
1	00	Stop Bit 0: 1bit 1: 2bit	0
	01	TxD Process 0: Disable 1: Enable	0
	02-03	CTS/RTS Flow Control 00: RTS/CTS Disable 10: CTS Enable 01: RTS Enable 11: RTS/CTS Enable	00
	04-07	Reserved	0
2	00-07	Reserved	0
3	00-07	Reserved	0
4	00-07	Not used	0
5	00-07	Not used	0
6	00-07	Not used	0
7	00-07	Not used	0

† All values are stored in Adapter's EEPROM.

ST-5212 (2 Channel Serial Interface RS-232)

- Valid Parameter length: 4 bytes
- Parameter Data:

Offset	Decimal Bit	Description	Default Value
0	00-03	Baud Rate 0000: 300bps 0101: 19200bps 0001: 1200bps 0110: 38400bps 0010: 2400bps 0111: 57600bps 0011: 4800bps 1000: 115200bps 0100: 9600bps Others: Unused	0100
	04-05	Data Bit 00: 7 Data bit 10: 9 Data bit 01: 8 Data bit Others: Unused	01
	06-07	Parity Bit 00: No Parity 10: Even Parity 01: Odd Parity Others: Unused	00
1	00	Stop Bit 0: 1bit 1: 2bit	0
	01	TxD Process 0: Disable 1: Enable	0
	02-03	CTS/RTS Flow Control 00: RTS/CTS Disable 10: CTS Enable 01: RTS Enable 11: RTS/CTS Enable	00
	04-07	Reserved 0	
2	00-03	Baud Rate 0000: 300bps 0101: 19200bps 0001: 1200bps 0110: 38400bps 0010: 2400bps 0111: 57600bps 0011: 4800bps 1000: 115200bps 0100: 9600bps Others: Unused	0100
	04-05	Data Bit 00: 7 Data bit 10: 9 Data bit 01: 8 Data bit Others: Unused	01
	06-07	Parity Bit 00: No Parity 10: Even Parity 01: Odd Parity Others: Unused	00
3	00	Stop Bit 0: 1bit 1: 2bit	0
	01	TxD Process 0: Disable 1: Enable	0
	02-03	CTS/RTS Flow Control 00: RTS/CTS Disable 10: CTS Enable 01: RTS Enable 11: RTS/CTS Enable	00
	04-07	Reserved	0
4	00-07	Not used	0
	00-07	Not used	0
	00-07	Not used	0
	00-07	Not used	0

† All values are stored in Adapter's EEPROM.

ST-5221 (1 Channel Serial Interface RS-422)

- Valid Parameter length: 4 bytes
- Parameter Data:

<i>Offset</i>	<i>Decimal Bit</i>	<i>Description</i>	<i>Default Value</i>
0	00-03	Baud Rate	0100
	04-05	Data Bit	01
	06-07	Parity Bit	00
1	00	Stop Bit	0
	01	TxD Process	0
	02-03	CTS/RTS Flow Control	00
	04-07	Reserved	0
2	00-07	Reserved	0
3	00-07	Reserved	0
4	00-07	Not used	0
5	00-07	Not used	0
6	00-07	Not used	0
7	00-07	Not used	0

† All values are stored in Adapter's EEPROM.

†† Same as 1.7.5.

ST-5231 (1 Channel Serial Interface RS-485)

- Valid Parameter length: 4 bytes
- Parameter Data:

<i>Offset</i>	<i>Decimal Bit</i>	<i>Description</i>	<i>Default Value</i>
0	00-03	Baud Rate	0100
	04-05	Data Bit	01
	06-07	Parity Bit	00
1	00	Stop Bit	0
	01	TxD Process	0
	02-03	CTS/RTS Flow Control	00
	04-07	Reserved	0
2	00-07	Reserved	0
3	00-07	Reserved	0
4	00-07	Not used	0
5	00-07	Not used	0
6	00-07	Not used	0
7	00-07	Not used	0

† All values are stored in Adapter's EEPROM.

†† Same as 1.7.6.

ST-5232 (2 Channel Serial Interface RS-485)

- Valid Parameter length: 4 bytes
- Parameter Data:

<i>Offset</i>	<i>Decimal Bit</i>	<i>Description</i>	<i>Default Value</i>
0	00-03	Baud Rate	0100
	04-05	Data Bit	01
	06-07	Parity Bit	00
1	00	Stop Bit	0
	01	TxD Process	0
	02-03	CTS/RTS Flow Control	00
	04-07	Reserved	0
2	00-03	Baud Rate	0100
	04-05	Data Bit	01
	06-07	Parity Bit	00
3	00	Stop Bit	0
	01	TxD Process	0
	02-03	CTS/RTS Flow Control	00
	04-07	Reserved	0
4	00-07	Not used	0
5	00-07	Not used	0
6	00-07	Not used	0
7	00-07	Not used	0

† All values are stored in Adapter's EEPROM.

†† Same as 1.7.5.

ST-5351 (1 Channel SSI Interface)

- Valid Parameter length: 2 bytes
- Parameter Data:

<i>Offset</i>	<i>Decimal Bit</i>	<i>Description</i>	<i>Default Value</i>
0	00-07	Reserved	0
1	00-07	Reserved	0
2	00-07	Not used	0
3	00-07	Not used	0
4	00-07	Not used	0
5	00-07	Not used	0
6	00-07	Not used	0
7	00-07	Not used	0

† All values are stored in Adapter's EEPROM.

ST-5422 (2 Channel PWM Output, 1.5A/24Vdc)

- Valid Parameter length: 2 bytes
- Parameter Data:

<i>Offset</i>	<i>Decimal Bit</i>	<i>Description</i>	<i>Default Value</i>
0	00-07	Reserved	0
1	00-07	Reserved	0
2	00-07	Not used	0
3	00-07	Not used	0
4	00-07	Not used	0
5	00-07	Not used	0
6	00-07	Not used	0
7	00-07	Not used	0

† All values are stored in Adapter's EEPROM.

ST-5442 (2 Channel PWM Output, 0.5A/24Vdc)

- Valid Parameter length: 2 bytes
- Parameter Data:

<i>Offset</i>	<i>Decimal Bit</i>	<i>Description</i>	<i>Default Value</i>
0	00-07	Reserved	0
1	00-07	Reserved	0
2	00-07	Not used	0
3	00-07	Not used	0
4	00-07	Not used	0
5	00-07	Not used	0
6	00-07	Not used	0
7	00-07	Not used	0

† All values are stored in Adapter's EEPROM.

ST-5444 (4 Channel PWM Output, 0.5A/24Vdc)

- Valid Parameter length: 2 bytes
- Parameter Data:

<i>Offset</i>	<i>Decimal Bit</i>	<i>Description</i>	<i>Default Value</i>
0	00-07	Reserved	0
1	00-07	Reserved	0
2	00-07	Not used	0
3	00-07	Not used	0
4	00-07	Not used	0
5	00-07	Not used	0
6	00-07	Not used	0
7	00-07	Not used	0

† All values are stored in Adapter's EEPROM.

ST-5641 (1 Channel Pulse Output, 0.5A/24Vdc)

- Valid Parameter length: 2 bytes
- Parameter Data:

<i>Offset</i>	<i>Decimal Bit</i>	<i>Description</i>	<i>Default Value</i>
0	00-07	Reserved	0
1	00-07	Reserved	0
2	00-07	Not used	0
3	00-07	Not used	0
4	00-07	Not used	0
5	00-07	Not used	0
6	00-07	Not used	0
7	00-07	Not used	0

† All values are stored in Adapter's EEPROM.

ST-5642 (2 Channel Pulse Output, 0.5A/24Vdc)

- Valid Parameter length: 2 bytes
- Parameter Data:

<i>Offset</i>	<i>Decimal Bit</i>	<i>Description</i>	<i>Default Value</i>
0	00-07	Reserved	0
1	00-07	Reserved	0
2	00-07	Not used	0
3	00-07	Not used	0
4	00-07	Not used	0
5	00-07	Not used	0
6	00-07	Not used	0
7	00-07	Not used	0

† All values are stored in Adapter's EEPROM.

ST-5651 (1 Channel Pulse Output, RS-422)

- Valid Parameter length: 2 bytes
- Parameter Data:

<i>Offset</i>	<i>Decimal Bit</i>	<i>Description</i>	<i>Default Value</i>
0	00-07	Reserved	0
1	00-07	Reserved	0
2	00-07	Not used	0
3	00-07	Not used	0
4	00-07	Not used	0
5	00-07	Not used	0
6	00-07	Not used	0
7	00-07	Not used	0

† All values are stored in Adapter's EEPROM.

Memory Register

Power Module

ST-7008 (Shield Module)

- Memory Register length: 0 byte
- Memory Register: none

ST-7108 (Common, 0Vdc)

- Memory Register length: 0 byte
- Memory Register: none

ST-7111 (Expansion Power Supply, Input 24Vdc, Output 1.0A/5Vdc)

- Memory Register length: 0 byte
- Memory Register: none

ST-7118 (Common, 24Vdc)

- Memory Register length: 0 byte
- Memory Register: none

ST-7188 (Common, 24Vdc/0Vdc)

- Memory Register length: 0 byte
- Memory Register: none

ST-7241 (Field Distributor, 5Vdc/24Vdc/48Vdc/110Vac/240Vac)

- Memory Register length: 0 byte
- Memory Register: none

ST-7408 (Shield Module, ID Type)

- Memory Register length: 0 byte
- Memory Register: none

ST-7508 (Common, 0Vdc, ID Type)

- Memory Register length: 0 byte
- Memory Register: none

ST-7511 (Expansion Power Supply, Input 24Vdc, Output 1.0A/5Vdc, ID Type)

- Memory Register length: 0 byte
- Memory Register: none

ST-7518 (Common, 24Vdc, ID Type)

- Memory Register length: 0 byte
- Memory Register: none

ST-7588 (Common, 24Vdc/0Vdc, ID Type)

- Memory Register length: 0 byte
- Memory Register: none

ST-7641 (Field Distributor, 5Vdc/24Vdc/48Vdc/110Vac/240Vac, ID Type)

- Memory Register length: 0 byte
- Memory Register: none

Discrete Input Module

ST-1114 (4- Positive Logic input, 5Vdc)

- Memory Register length: 0 byte
- Memory Register: none

ST-1124 (4- Negative Logic input, 5Vdc)

- Memory Register length: 0 byte
- Memory Register: none

ST-1214 (4- Positive Logic input, 24Vdc)

- Memory Register length: 0 byte
- Memory Register: none

ST-1224 (4- Negative Logic input, 24Vdc)

- Memory Register length: 0 byte
- Memory Register: none

ST-1314 (4- Positive Logic input, 48Vdc)

- Memory Register length: 0 byte
- Memory Register: none

ST-1324 (4- Negative Logic input, 48Vdc)

- Memory Register length: 0 byte
- Memory Register: none

ST-131F (16- Positive Logic input, 48Vdc)

- Memory Register length: 0 byte
- Memory Register: none

ST-1218 (8- Positive Logic input, 24Vdc)

- Memory Register length: 0 byte
- Memory Register: none

ST-1228 (8- Negative Logic input, 24Vdc)

- Memory Register length: 0 byte
- Memory Register: none

ST-121F (16- Positive Logic input, 24Vdc)

- Memory Register length: 0 byte
- Memory Register: none

ST-1804 (4-ac input, 110Vac)

- Memory Register length: 0 byte
- Memory Register: none

ST-1904 (4-ac input, 240Vac)

- Memory Register length: 0 byte
- Memory Register: none

Discrete Output Module

ST-2114 (4-TTL Inverting (Positive Logic) output, 5Vdc 20mA)

- Memory Register length: 0 byte
- Memory Register: none

ST-2124 (4-TTL Non-Inverting (Positive Logic) output, 5Vdc 20mA)

- Memory Register length: 0 byte
- Memory Register: none

ST-2314 (4- Negative Logic output, 24Vdc 0.5A)

- Memory Register length: 0 byte
- Memory Register: none

ST-2324 (4- Positive Logic output, 24Vdc 0.5A)

- Memory Register length: 0 byte
- Memory Register: none

ST-2414 (4- Negative Logic output, Diagnostics, 24Vdc 0.5A)

- Memory Register length: 0 byte
- Memory Register: none

ST-2424 (4- Positive Logic output, Diagnostics, 24Vdc 0.5A)

- Memory Register length: 0 byte
- Memory Register: none

ST-2514 (4- Negative Logic output, Diagnostics, 24Vdc 2A)

- Memory Register length: 0 byte
- Memory Register: none

ST-2524 (4- Positive Logic output, Diagnostics, 24Vdc 2A)

- Memory Register length: 0 byte
- Memory Register: none

ST-2318 (8- Negative Logic output, 24Vdc 0.5A)

- Memory Register length: 0 byte
- Memory Register: none

ST-2328 (8- Positive Logic output, 24Vdc 0.5A)

- Memory Register length: 0 byte
- Memory Register: none

ST-221F (16- Negative Logic output, 24Vdc 0.1A)

- Memory Register length: 0 byte
- Memory Register: none

ST-222F (16- Positive Logic output, 24Vdc 0.1A)

- Memory Register length: 0 byte
- Memory Register: none

ST-2742 (2-relay output, 240Vac 2A)

- Memory Register length: 0 byte
- Memory Register: none

ST-2744 (4-relay output, 240Vac 2A)

- Memory Register length: 0 byte
- Memory Register: none

ST-2748 (8-relay output, 240Vac 2A)

- Memory Register length: 0 byte
- Memory Register: none

ST-2852 (2-triac output, 120Vac 0.5A)

- Memory Register length: 0 byte
- Memory Register: none

Analog Input Module

ST-3114 (4-current analog input, 0~20mA, 12bit)

- Memory Register length: 10 bytes
- Memory Register:

<i>Offset</i>	<i>Access</i>	<i>Decimal Bit</i>	<i>Description</i>	<i>Default Value</i>
0	R	00-07	Channel 0 Input Data Low 8 bits	
1	R	00-03	Channel 0 Input Data High 4 bits	
		04-07	not used	0
2	R	00-07	Channel 1 Input Data Low 8 bits	
3	R	00-03	Channel 1 Input Data High 4 bits	
		04-07	not used	0
4	R	00-07	Channel 2 Input Data Low 8 bits	
5	R	00-03	Channel 2 Input Data High 4 bits	
		04-07	not used	0
6	R	00-07	Channel 3 Input Data Low 8 bits	
7	R	00-03	Channel 3 Input Data High 4 bits	
		04-07	not used	0
8	R	00-07	Reserved	0
9	R	00-07	Reserved	0

ST-3118 (8-current analog input, 0~20mA, 12bit)

- Memory Register length: 0 byte
- Memory Register: none

ST-3134 (4-current analog input, 0~20mA, 14bit)

- Memory Register length: 10 bytes
- Memory Register:

<i>Offset</i>	<i>Access</i>	<i>Decimal Bit</i>	<i>Description</i>	<i>Default Value</i>
0	R	00-07	Channel 0 Input Data Low 8 bits	
1	R	00-05	Channel 0 Input Data High 6 bits	
		06, 07	not used	0
2	R	00-07	Channel 1 Input Data Low 8 bits	
3	R	00-05	Channel 1 Input Data High 6 bits	
		06, 07	not used	0
4	R	00-07	Channel 2 Input Data Low 8 bits	
5	R	00-05	Channel 2 Input Data High 6 bits	
		06, 07	not used	0
6	R	00-07	Channel 3 Input Data Low 8 bits	
7	R	00-05	Channel 3 Input Data High 6 bits	
		06, 07	not used	0
8	R	00-07	Reserved	0
9	R	00-07	Reserved	0

ST-3214 (4-current analog input, 4~20mA, 12bit)

- Memory Register length: 10 bytes
- Memory Register:

<i>Offset</i>	<i>Access</i>	<i>Decimal Bit</i>	<i>Description</i>	<i>Default Value</i>
0	R	00-07	Channel 0 Input Data Low 8 bits	
1	R	00-03	Channel 0 Input Data High 4 bits	
		04-07	not used	0
2	R	00-07	Channel 1 Input Data Low 8 bits	
3	R	00-03	Channel 1 Input Data High 4 bits	
		04-07	not used	0
4	R	00-07	Channel 2 Input Data Low 8 bits	
5	R	00-03	Channel 2 Input Data High 4 bits	
		04-07	not used	0
6	R	00-07	Channel 3 Input Data Low 8 bits	
7	R	00-03	Channel 3 Input Data High 4 bits	
		04-07	not used	0
8	R	00-03	Alarm Status Bit for individual channels - Bit 00 corresponds to input channel 0, bit 01 corresponds to input channel 1, and so on. When set (1), the input signal is below the input channel's minimum range (3mA). And Input Data will be 0x8000 (-32678)	
		04-07	Reserved	0
9	R	00-07	Reserved	0

ST-3218 (8-current analog input, 4~20mA, 12bit)

- Memory Register length: 0 byte
- Memory Register: none

ST-3234 (4-current analog input, 4~20mA, 14bit)

- Memory Register length: 10 bytes
- Memory Register:

<i>Offset</i>	<i>Access</i>	<i>Decimal Bit</i>	<i>Description</i>	<i>Default Value</i>
0	R	00-07	Channel 0 Input Data Low 8 bits	
1	R	00-05	Channel 0 Input Data High 6 bits	
		06, 07	not used	0
2	R	00-07	Channel 1 Input Data Low 8 bits	
3	R	00-05	Channel 1 Input Data High 6 bits	
		06, 07	not used	0
4	R	00-07	Channel 2 Input Data Low 8 bits	
5	R	00-05	Channel 2 Input Data High 6 bits	
		06, 07	not used	0
6	R	00-07	Channel 3 Input Data Low 8 bits	
7	R	00-05	Channel 3 Input Data High 6 bits	
		06, 07	not used	0
8	R	00-03	Alarm Status Bit for individual channels - Bit 00 corresponds to input channel 0, bit 01 corresponds to input channel 1, and so on. When set (1), the input signal is below the input channel's minimum range (3mA). And Input Data will be 0x8000 (-32678)	
		04-07	Reserved	0
9	R	00-07	Reserved	0

ST-3424 (4-voltage analog input, 0~10V, 12bit)

- Memory Register length: 10 bytes
- Memory Register:

<i>Offset</i>	<i>Access</i>	<i>Decimal Bit</i>	<i>Description</i>	<i>Default Value</i>
0	R	00-07	Channel 0 Input Data Low 8 bits	
1	R	00-03	Channel 0 Input Data High 4 bits	
		04-07	not used	0
2	R	00-07	Channel 1 Input Data Low 8 bits	
3	R	00-03	Channel 1 Input Data High 4 bits	
		04-07	not used	0
4	R	00-07	Channel 2 Input Data Low 8 bits	
5	R	00-03	Channel 2 Input Data High 4 bits	
		04-07	not used	0
6	R	00-07	Channel 3 Input Data Low 8 bits	
7	R	00-03	Channel 3 Input Data High 4 bits	
		04-07	not used	0
8	R	00-07	Reserved	0
9	R	00-07	Reserved	0

ST-3428 (8-voltage analog input, 0~10V, 12bit)

- Memory Register length: 0 byte
- Memory Register: none

ST-3444 (4-voltage analog input, 0~10V, 14bit)

- Memory Register length: 10 bytes
- Memory Register:

<i>Offset</i>	<i>Access</i>	<i>Decimal Bit</i>	<i>Description</i>	<i>Default Value</i>
0	R	00-07	Channel 0 Input Data Low 8 bits	
1	R	00-05	Channel 0 Input Data High 6 bits	
		06, 07	not used	0
2	R	00-07	Channel 1 Input Data Low 8 bits	
3	R	00-05	Channel 1 Input Data High 6 bits	
		06, 07	not used	0
4	R	00-07	Channel 2 Input Data Low 8 bits	
5	R	00-05	Channel 2 Input Data High 6 bits	
		06, 07	not used	0
6	R	00-07	Channel 3 Input Data Low 8 bits	
7	R	00-05	Channel 3 Input Data High 6 bits	
		06, 07	not used	0
8	R	00-07	Reserved	0
9	R	00-07	Reserved	0

ST-3524 (4-voltage analog input, -10~10V, 12bit)

- Memory Register length: 10 bytes
- Memory Register:

<i>Offset</i>	<i>Access</i>	<i>Decimal Bit</i>	<i>Description</i>	<i>Default Value</i>
0	R	00-07	Channel 0 Input Data Low 8 bits	
1	R	00-06	Channel 0 Input Data High 7 bits	
		07	Sign Bit	
2	R	00-07	Channel 1 Input Data Low 8 bits	
3	R	00-06	Channel 1 Input Data High 7 bits	
		07	Sign Bit	0
4	R	00-07	Channel 2 Input Data Low 8 bits	
5	R	00-06	Channel 2 Input Data High 7 bits	
		07	Sign Bit	0
6	R	00-07	Channel 3 Input Data Low 8 bits	
7	R	00-06	Channel 3 Input Data High 7 bits	
		07	Sign Bit	0
8	R	00-07	Reserved	0
9	R	00-07	Reserved	0

ST-3544 (4-voltage analog input, -10~10V, 14bit)

- Memory Register length: 10 bytes
- Memory Register:

<i>Offset</i>	<i>Access</i>	<i>Decimal Bit</i>	<i>Description</i>	<i>Default Value</i>
0	R	00-07	Channel 0 Input Data Low 8 bits	
1	R	00-06	Channel 0 Input Data High 7 bits	
		07	Sign Bit	
2	R	00-07	Channel 1 Input Data Low 8 bits	
3	R	00-06	Channel 1 Input Data High 7 bits	
		07	Sign Bit	0
4	R	00-07	Channel 2 Input Data Low 8 bits	
5	R	00-06	Channel 2 Input Data High 7 bits	
		07	Sign Bit	0
6	R	00-07	Channel 3 Input Data Low 8 bits	
7	R	00-06	Channel 3 Input Data High 7 bits	
		07	Sign Bit	0
8	R	00-07	Reserved	0
9	R	00-07	Reserved	0

ST-3624 (4-voltage analog input, 0~5V, 12bit)

- Memory Register length: 10 bytes
- Memory Register:

<i>Offset</i>	<i>Access</i>	<i>Decimal Bit</i>	<i>Description</i>	<i>Default Value</i>
0	R	00-07	Channel 0 Input Data Low 8 bits	
1	R	00-06	Channel 0 Input Data High 7 bits	
		04-07	not used	0
2	R	00-07	Channel 1 Input Data Low 8 bits	
3	R	00-03	Channel 1 Input Data High 4 bits	
		04-07	not used	0
4	R	00-07	Channel 2 Input Data Low 8 bits	
5	R	00-03	Channel 2 Input Data High 4 bits	
		04-07	not used	0
6	R	00-07	Channel 3 Input Data Low 8 bits	
7	R	00-03	Channel 3 Input Data High 4 bits	
		04-07	not used	0
8	R	00-07	Reserved	0
9	R	00-07	Reserved	0

ST-3644 (4-voltage analog input, 0~5V, 14bit)

- Memory Register length: 10 bytes
- Memory Register:

<i>Offset</i>	<i>Access</i>	<i>Decimal Bit</i>	<i>Description</i>	<i>Default Value</i>
0	R	00-07	Channel 0 Input Data Low 8 bits	
1	R	00-05	Channel 0 Input Data High 6 bits	
		06, 07	not used	0
2	R	00-07	Channel 1 Input Data Low 8 bits	
3	R	00-05	Channel 1 Input Data High 6 bits	
		06, 07	not used	0
4	R	00-07	Channel 2 Input Data Low 8 bits	
5	R	00-05	Channel 2 Input Data High 6 bits	
		06, 07	not used	0
6	R	00-07	Channel 3 Input Data Low 8 bits	
7	R	00-05	Channel 3 Input Data High 6 bits	
		06, 07	not used	0
8	R	00-07	Reserved	0
9	R	00-07	Reserved	0

ST-3702 (2- RTD/Resistance input)

- Memory Register length: 8 bytes
- Memory Register:

<i>Offset</i>	<i>Access</i>	<i>Decimal Bit</i>	<i>Description</i>	<i>Default Value</i>
0	R	00-07	Channel 0 Input Data Low 8 bits	
1	R	00-06	Channel 0 Input Data High 7 bits	
		07	Sign Bit	
2	R	00-07	Channel 1 Input Data Low 8 bits	
3	R	00-06	Channel 1 Input Data High 7 bits	
		07	Sign Bit	
4	R	00-07	Sensor Type (same as configuration parameters)	0
5	R	00-07	Temperature Type (same as configuration parameters)	0
6	R	00, 01	Alarm Status Bit for individual channels - Bit 00 corresponds to input channel 0, bit 01 corresponds to input channel 1. When set (1), the input signal is below the input channel's minimum range or above the input channel's maximum range. And Input Data will be 0x8000(-32678)	
		02-07	Reserved	0
7	R	00-07	Reserved	

† Offset 4, 5: All values are not stored in Adapter's EEPROM.

ST-3704 (4- RTD/Resistance input)

- Memory Register length: 0 byte
- Memory Register: none

ST-3708 (8- RTD/Resistance input)

- Memory Register length: 0 byte
- Memory Register: none

ST-3802 (2- Thermocouple/mV input)

- Memory Register length: 12 bytes
- Memory Register:

Offset	Access	Decimal Bit	Description	Default Value
0	R	00-07	Channel 0 Input Data Low 8 bits	
1	R	00-06	Channel 0 Input Data High 7 bits	
		07	Sign Bit	
2	R	00-07	Channel 1 Input Data Low 8 bits	
3	R	00-06	Channel 1 Input Data High 7 bits	
		07	Sign Bit	
4	R	00-07	Sensor Type (same as configuration parameters)	0
5	R	00-07	Temperature Type (same as configuration parameters)	0
6	R	00, 01	Alarm Status Bit for individual channels - Bit 00 corresponds to input channel 0, bit 01 corresponds to input channel 1. When set (1), the input signal is below the input channel's minimum range or above the input channel's maximum range. And Input Data will be 0x8000 (-32678)	
		02-07	Reserved	0
7	R	00, 01	Burn-Out Bit for individual channels - Bit 00 corresponds to input channel 0, bit 01 corresponds to input channel 1. When set (1), the input channel is burn-out. And Input Data will be 0x8000 (-32678)	
		02-07	Reserved	0
8	R	00-07	Cold Junction Low 8 bits	
9	R	00-07	Cold Junction High 8 bits	
10	R/W	00-07	Cold Junction Offset Low 8 bits	
11	R/W	00-07	Cold Junction Offset High 8 bits	

† Offset 4, 5, 10, 11: All values are not stored in Adapter's EEPROM.

ST-3804 (4- Thermocouple/mV input)

- Memory Register length: 0 byte
- Memory Register: none

ST-3808 (8- Thermocouple/mV input)

- Memory Register length: 0 byte
- Memory Register: none

Analog Output Module

ST-4112 (2-current analog output, 0~20mA, 12bit)

- Memory Register length: 12 bytes
- Memory Register:

Offset	Access	Decimal Bit	Description	Default Value
0	R	00-07	Channel 0 Output Data Low 8 bits	0
1	R	00-03	Channel 0 Output Data High 4 bits	0
		04-07	not used	0
2	R	00-07	Channel 1 Output Data Low 8 bits	0
3	R	00-03	Channel 1 Output Data High 4 bits	0
		04-07	not used	0
4	R	00-07	Reserved	0
5	R	00-07	Reserved	0
6	R	00-07	Fault Action	0
7	R	00-07	Reserved	0
8	R	00-07	Channel 0 Fault Value Low Byte	0
9	R	00-07	Channel 0 Fault Value High Byte	0
10	R	00-07	Channel 1 Fault Value Low Byte	0
11	R	00-07	Channel 1 Fault Value High Byte	0

† Offset 6-11: All values are not stored in Adapter's EEPROM.

ST-4114 (4-current analog output, 0~20mA, 12bit)

- Memory Register length: 0 byte
- Memory Register: none

ST-4212 (2-current analog output, 4~20mA, 12bit)

- Memory Register length: 12 bytes
- Memory Register:

<i>Offset</i>	<i>Access</i>	<i>Decimal Bit</i>	<i>Description</i>	<i>Default Value</i>
0	R	00-07	Channel 0 Output Data Low 8 bits	0
1	R	00-03	Channel 0 Output Data High 4 bits	0
		04-07	not used	0
2	R	00-07	Channel 1 Output Data Low 8 bits	0
3	R	00-03	Channel 1 Output Data High 4 bits	0
		04-07	not used	0
4	R	00-07	Reserved	0
5	R	00-07	Reserved	0
6	R	00-07	Fault Action (Same as configuration parameters)	0
7	R	00-07	Reserved	0
8	R	00-07	Channel 0 Fault Value Low Byte (Same as configuration parameters)	0
9	R	00-07	Channel 0 Fault Value High Byte (Same as configuration parameters)	0
10	R	00-07	Channel 1 Fault Value Low Byte (Same as configuration parameters)	0
11	R	00-07	Channel 1 Fault Value High Byte (Same as configuration parameters)	0

ST-4214 (4-current analog output, 4~20mA, 12bit)

- Memory Register length: 0 byte
- Memory Register: none

ST-4422 (2-voltage analog output, 0~10Vdc, 12bit)

- Memory Register length: 12 bytes
- Memory Register:

<i>Offset</i>	<i>Access</i>	<i>Decimal Bit</i>	<i>Description</i>	<i>Default Value</i>
0	R	00-07	Channel 0 Output Data Low 8 bits	0
1	R	00-03	Channel 0 Output Data High 4 bits	0
		04-07	not used	0
2	R	00-07	Channel 1 Output Data Low 8 bits	0
3	R	00-03	Channel 1 Output Data High 4 bits	0
		04-07	not used	0
4	R	00-07	Reserved	0
5	R	00-07	Reserved	0
6	R	00-07	Fault Action (Same as configuration parameters)	0
7	R	00-07	Reserved	0
8	R	00-07	Channel 0 Fault Value Low Byte (Same as configuration parameters)	0
9	R	00-07	Channel 0 Fault Value High Byte (Same as configuration parameters)	0
10	R	00-07	Channel 1 Fault Value Low Byte (Same as configuration parameters)	0
11	R	00-07	Channel 1 Fault Value High Byte (Same as configuration parameters)	0

† Offset 6-11: All values are not stored in Adapter's EEPROM.

ST-4424 (4-voltage analog output, 0~10Vdc, 12bit)

- Memory Register length: 0 byte
- Memory Register: none

ST-4474 (4-voltage analog output, 0~10Vdc, 12bit, Sensor Connector)

- Memory Register length: 0 byte
- Memory Register: none

ST-4491 (1-voltage analog output, 0~10Vdc, 12bit, Manual Type)

- Memory Register length: 0 byte
- Memory Register: none

ST-4522 (2-voltage analog output, -10~10Vdc, 12bit)

- Memory Register length: 12 bytes
- Memory Register:

<i>Offset</i>	<i>Access</i>	<i>Decimal Bit</i>	<i>Description</i>	<i>Default Value</i>
0	R	00-07	Channel 0 Output Data Low 8 bits	0
1	R	00-03	Channel 0 Output Data High 4 bits	0
		04-07	not used	0
2	R	00-07	Channel 1 Output Data Low 8 bits	0
3	R	00-03	Channel 1 Output Data High 4 bits	0
		04-07	not used	0
4	R	00-07	Reserved	0
5	R	00-07	Reserved	0
6	R	00-07	Fault Action (Same as configuration parameters)	0
7	R	00-07	Reserved	0
8	R	00-07	Channel 0 Fault Value Low Byte (Same as configuration parameters)	0
9	R	00-07	Channel 0 Fault Value High Byte (Same as configuration parameters)	0
10	R	00-07	Channel 1 Fault Value Low Byte (Same as configuration parameters)	0
11	R	00-07	Channel 1 Fault Value High Byte (Same as configuration parameters)	0

† Offset 6-11: All values are not stored in Adapter's EEPROM

ST-4622 (2-voltage analog output, 0~5Vdc, 12bit)

- Memory Register length: 12 bytes
- Memory Register:

<i>Offset</i>	<i>Access</i>	<i>Decimal Bit</i>	<i>Description</i>	<i>Default Value</i>
0	R	00-07	Channel 0 Output Data Low 8 bits	0
1	R	00-03	Channel 0 Output Data High 4 bits	0
		04-07	not used	0
2	R	00-07	Channel 1 Output Data Low 8 bits	0
3	R	00-03	Channel 1 Output Data High 4 bits	0
		04-07	not used	0
4	R	00-07	Reserved	0
5	R	00-07	Reserved	0
6	R	00-07	Fault Action (Same as configuration parameters)	0
7	R	00-07	Reserved	0
8	R	00-07	Channel 0 Fault Value Low Byte (Same as configuration parameters)	0
9	R	00-07	Channel 0 Fault Value High Byte (Same as configuration parameters)	0
10	R	00-07	Channel 1 Fault Value Low Byte (Same as configuration parameters)	0
11	R	00-07	Channel 1 Fault Value High Byte (Same as configuration parameters)	0

† Offset 6-11: All values are not stored in Adapter's EEPROM

ST-4911 (1-currunt analog output, 0~1A, 12bit)

- Memory Register length: 0 byte
- Memory Register: none

Special Module

ST-5101 (1 Channel High Speed Counter 5Vdc)

- Memory Register length: 24 bytes
- Memory Register:

Offset	Access	Decimal Bit	Description	Default Value
0	R	00-07	Current count value Low byte	0
1	R	00-07	Current count value Middle byte	0
2	R	00-07	Current count value High byte	0
3	R	00-07	Always 0	0
4	R	00-07	Status Low (compared flags)	0
5	R	00-07	Status High (same as LED display)	0
6	R	00-07	Output Terminal (OT) Control	0
7	R	00-07	SSR (Special Selection Register)	0
8	R	00-07	Gate Function/Counter Mode (Same as configuration parameters)	0
9	R	00-07	Gate Sampling Time/Input Filter (Same as configuration parameters)	0
10	R	00-07	Don't care	0
11	R	00-07	Don't care	0
12	R	00-07	Stored count value Low byte	0
13	R	00-07	Stored count value Middle byte	0
14	R	00-07	Stored count value High byte	0
15	R	00-07	Always 0	0
16	R	00-07	Initial Counter Value Low byte (Initial counter or PWM Frequency value)	0
17	R	00-07	Initial Counter Value Middle byte (Initial counter or PWM Frequency value)	0
18	R	00-07	Initial count value High byte (Initial counter or PWM Frequency value)	0
19	R	00-07	Always 0	0
20	R	00-07	Compare count value Low byte	0
21	R	00-07	Compare count value Middle byte	0
22	R	00-07	Compare count value High byte	0
23	R	00-07	Always 0	0

† Offset 8-9: All values are not stored in Adapter's EEPROM.

ST-5111 (1 Channel High Speed Counter 24Vdc)

- Memory Register length: 24 bytes
- Memory Register:

Offset	Access	Decimal Bit	Description	Default Value
0	R	00-07	Current count value Low byte	0
1	R	00-07	Current count value Middle byte	0
2	R	00-07	Current count value High byte	0
3	R	00-07	Always 0	0
4	R	00-07	Status Low (compared flags)	0
5	R	00-07	Status High (same as LED display)	0
6	R	00-07	Output Terminal (OT) Control	0
7	R	00-07	SSR (Special Selection Register)	0
8	R	00-07	Gate Function/Counter Mode (Same as configuration parameters)	0
9	R	00-07	Gate Sampling Time/Input Filter (Same as configuration parameters)	0
10	R	00-07	Don't care	0
11	R	00-07	Don't care	0
12	R	00-07	Stored count value Low byte	0
13	R	00-07	Stored count value Middle byte	0
14	R	00-07	Stored count value High byte	0
15	R	00-07	Always 0	0
16	R	00-07	Initial Counter Value Low byte (Initial counter or PWM Frequency value)	0
17	R	00-07	Initial Counter Value Middle byte (Initial counter or PWM Frequency value)	0
18	R	00-07	Initial count value High byte (Initial counter or PWM Frequency value)	0
19	R	00-07	Always 0	0
20	R	00-07	Compare count value Low byte	0
21	R	00-07	Compare count value Middle byte	0
22	R	00-07	Compare count value High byte	0
23	R	00-07	Always 0	0

† Offset 8-9: All values are not stored in Adapter's EEPROM.

ST-5112 (2 Channel High Speed Counter 24Vdc)

- Memory Register length: 0 byte
- Memory Register: none

ST-5114 (4 Channel High Speed Counter 24Vdc)

- Memory Register length: 0 byte
- Memory Register: none

ST-5211 (1 Channel Serial Interface RS-232)

- Memory Register length: 0 byte
- Memory Register: none

ST-5212 (2 Channel Serial Interface RS-232)

- Memory Register length: 0 byte
- Memory Register: none

ST-5221 (1 Channel Serial Interface RS-422)

- Memory Register length: 0 byte
- Memory Register: none

ST-5231 (1 Channel Serial Interface RS-485)

- Memory Register length: 0 byte
- Memory Register: none

ST-5232 (2 Channel Serial Interface RS-485)

- Memory Register length: 0 byte
- Memory Register: none

ST-5351 (1 Channel SSI Interface)

- Memory Register length: 0 byte
- Memory Register: none

ST-5422 (2 Channel PWM Output, 1.5A/24Vdc)

- Memory Register length: 0 byte
- Memory Register: none

ST-5442 (2 Channel PWM Output, 0.5A/24Vdc)

- Memory Register length: 0 byte
- Memory Register: none

ST-5444 (4 Channel PWM Output, 0.5A/24Vdc)

- Memory Register length: 0 byte
- Memory Register: none

ST-5641 (1 Channel Pulse Output, 0.5A/24Vdc)

- Memory Register length: 0 byte
- Memory Register: none

ST-5642 (2 Channel Pulse Output, 0.5A/24Vdc)

- Memory Register length: 0 byte
- Memory Register: none

ST-5651 (1 Channel Pulse Output, RS-422)

- Memory Register length: 0 byte
- Memory Register: none

Appendix

A

Product Certifications and Installation Guidelines for Conformance

This appendix describes the compliance markings that appear on PACSystems RST products and the corresponding standards to which the products have been certified. This appendix also provides installation requirements for conformance to standards and additional safety guidelines for installing in the European Union.

Important Notes

Solid state equipment has operational characteristics differing from those of electromechanical equipment.

Safety Guidelines for the Application, Installation and Maintenance of Solid State Controls describes some important differences between solid state equipment and hard-wired electromechanical devices.

Because of this difference, and also because of the wide variety of uses for solid state equipment, all persons responsible for applying this equipment must ensure that each intended application of this equipment is acceptable.

In no event will GE be responsible or liable for indirect or consequential damages resulting from the use or application of this equipment.





The examples and diagrams in this manual are included solely for illustrative purposes. Because of the many variables and requirements associated with any particular installation, GE cannot assume responsibility or liability for actual use based on the examples and diagrams.

Safety Notes

Warning

The modules are equipped with electronic components that may be destroyed by electrostatic discharge. When handling the modules, ensure that the environment (persons, workplace and packing) is well grounded. Avoid touching conductive components, for example, RSTi Bus Pin.

Agency Approvals

Description	Agency Standard or Marking	Comments
N.A. Safety for Industrial Control Equipment		Certification by Underwriter's Laboratories to UL 508 standard and equivalent CSA C22.2 No 142-M1987 standard
N.A. Safety for Hazardous Areas Class I, Div. 2, Groups A, B, C, D		Certification by Underwriter's Laboratories to ANSI/ISA 12.12.01 standard and equivalent CSA C22.2 No 213-M1987 standard (applies to module revision "B" and later)
Low Voltage Directive European Safety for Industrial Control Equipment		Certification in accordance with European Directives; Refer to Declaration of Conformity found at http://www.ge-ip.com/ for a complete list of approved products.
Electromagnetic Compatibility Directive European EMC for Industrial Control Equipment		Certification in accordance with European Directives; Refer to Declaration of Conformity found at http://www.ge-ip.com/ for a complete list of approved modules
Explosive Atmospheres Directive European Safety for Hazardous Areas Equipment Group II, Category 3, Gas Groups A, B, C		Certification in accordance with European Directives and Independent 3rd Party Assessment Certificate; Refer to Declaration of Conformity found a http://www.ge-ip.com/ for complete list of approved products.

Note: The agency approvals listed above and on the Declaration of Conformities are believed to be accurate; however, a product's agency approvals should be verified by the marking on the unit itself.

UL Class 1 Division 2 & ATEX Zone 2 Hazardous Area Requirements

- 1) EQUIPMENT LABELED WITH REFERENCE TO CLASS I, GROUPS A, B, C & D, DIV. 2 OR ZONE 2 HAZARDOUS LOCATIONS IS SUITABLE FOR USE IN CLASS I, DIVISION 2, GROUPS A, B, C, D, ZONE 2 OR NON-HAZARDOUS LOCATIONS ONLY.
- 2) WARNING – EXPLOSION HAZARD—SUBSTITUTION OF COMPONENTS MAY IMPAIR SUITABILITY FOR CLASS I, DIVISION 2 & ATEX ZONE2.
- 3) WARNING – EXPLOSION HAZARD – TURN OFF POWER BEFORE REPLACING OR WIRING MODULES. DO NOT CONNECT OR DISCONNECT EQUIPMENT UNLESS POWER HAS BEEN SWITCHED OFF OR THE AREA IS KNOWN TO BE NON-HAZARDOUS.

ATEX Class 1 Zone 2 Hazardous Areas Requirements

Certification string: Ex nA IIC T4 Gc (Modules without Relay) & Ex nA nC IIC T4 Gc (Modules with Relay)

Standards Covered: EN 60079-0:2012, EN 60079-15:2010

Special Conditions for Safe Usage:

- a) The device shall be mounted in an ATEX certified enclosure with a minimum ingress protection rating of at least IP54 as defined in IEC/EN 60529 and used in an area of not more than pollution degree 2 as defined by IEC60664-1. Enclosure must utilize a tool removable cover or door.
- b) Provisions shall be made to prevent the rated voltage being exceeded by the transient disturbances of more than 140%.
- c) Earthing is accomplished through mounting of modules on a din rail.
- d) Subject devices are for operation in Ambient Temperature Range: -20 °C to +55 °C (refer the respective module specs for applicable temperature range)

Environmental Specifications

Power Modules, Discrete Inputs, Discrete Outputs, Analog Inputs, and Analog Outputs

Table 211: Environment Specification

Operating Temperature	<u>ST-1xxx,2xxx, 7xxx :</u> -20°C to 55°C for UL applications ; -20°C to 60°C for non-UL applications <u>ST-3xxx, 4xxx[†], 51xx[†], 53xx,54xx,56xx :</u> 0°C to 55°C for UL applications ; 0°C to 60°C for non-UL applications [†] for ST-4491,ST-5101,ST-5111 : 0°C to 55°C for UL applications ; -20°C to 60°C for non-UL applications <u>ST-52xx :</u> 0°C to 55°C for UL applications ; -20°C to 55°C for non-UL applications
Non-Operating Temperature	-40°C to 85°C
Relative Humidity	5% to 90% Non-condensing
Operating Altitude	2,000m
Mounting	DIN Rail
Shock Operating	10g
Shock Non-Operating	30g
Vibration/Shock Resistance	Displacement : 0.012 Inch p-p from 10-57Hz Acceleration : 2G's from 57-500Hz Sweep Rate : 1 octave Per Minute Axes to test: x,y,z Frequency Sweeps Per Axis : 10
Installation Pos. / Protect. Class	Variable / IP20
Isolation	DC Module (Including Analog Module) : Terminal Block to F.G 500Vac/1min AC Module : Terminal Block to F.G 1500Vac/1min Relay Module : Terminal Block to F.G 2500Vac/1min

Government Regulations

U.S., Canadian, Australian, and European regulations are intended to prevent equipment from interfering with approved transmissions or with the operation of other equipment through the AC power source.

The PACSystems RSTi family of products has been tested and found to meet or exceed the requirements of U.S. (47 CFR 15), Canadian (ICES-003), Australian (AS/NZS 3548), and European (EN 61000-6-4:2007) regulations for Class A digital devices when installed in accordance with the guidelines noted in this manual. These various regulations share commonality in content and test levels with that of CISPR

22 and based on this commonality testing to the each individual standard was deemed inappropriate.

The FCC requires the following note to be published according to FCC guidelines:

Note: This equipment has been tested and found to comply with the limits for a Class A digital device, pursuant to Part 15 of the FCC Rules. These limits are designed to provide reasonable protection against harmful interference when the equipment is operated in a commercial environment. This equipment generates, uses, and can radiate radio frequency energy and, if not installed and used in accordance with the instruction manual, may cause harmful interference to radio communications. Operation of this equipment in a residential area is likely to cause harmful interference in which case user will be required to correct the interference at its own expense.

Industry Canada requires the following note to be published:

Note: This Class A digital apparatus complies with Canadian ICES-003.

Abbreviations

Items	Description
AC	Analog Channel
CHTO	Channel Timeout
CLRCNT	Clear Real Pulse Output Counter
CP	Counter Preset
CR	Counter Reset
CRCH	Control Received data Channel
CRRQ	Control Received data Request
CST	Clear Status
CTCH	Control Transmit data Channel
DC	Digital Channel
DEC	Data Decrement
DIN	Digital Input Current Status
E/C	End Character
ECP	Enable Continuous Pulse
FG	Field Ground
F/L	Fixed Length
GND	Ground
HSC	High Speed Counter
IA	Initialization Acknowledge
IDS	Input Data Selection
IL	Input Length
INC	Data Increment
IR	Initialization Request
LDF	Latched Data Flag
LED	Light Emitting Device
OL	Output Length
OT	Output Terminal
PE	Process Equal
PU	Process Underflow
PWM	Pulse Width Module
RA	Receive Acknowledge
RBO	RxD Buffer Overrun
RBOF	RxD Buffer Overflow
RFRM	Framing Error
RPAT	Parity Error
RPST	Return Preset
RR	Receive Request
RRCH	Return Received data Channel
RRRQ	Return Received data Request
RTBM	Return Transmit data Buffering Machine State
RTCH	Return Transmit data Channel

RxD	
SAIN	Status A Terminal Input
SBIN	Status B Terminal Input
S/C	Start Character
SDN	Status Counter Down
SGIN	Status G Terminal Input
SOF	Status Overflow
SOT	Status Output Terminal
SSI	Synchronous Serial Interface
SUF	Status Underflow
SUP	Status Counter Up
TA	Transmit Acknowledge
TBMS	TX Buffering Machine State Error
TPA	Transmit Processing Acknowledge
TPR	Transmit Processing Request
TR	Transmit Request
WARN	Warning
WFP	Warning of Field Power
WSSID	Warning of SSI Data
WSSIF	Warning of SSI Frame