

1 DESCRIPTION

The Horner Millivolt Input Modules (HE693ADC406 / 409) allow DC millivolt-level signals to be directly connected to the PLC without external signal processing (transducers, transmitters, etc.). Analog and digital processing of the signal is performed by the module, and millivolt values are written to the PLC %AI input table with 14-bit resolution. The module features 4 channels, and an input range that is selectable from +/-25mVdc, +/-50mVdc, and +/-100mVdc. The input range is selectable via the configuration software or a Hand-Held Programmer (HHP). Selectable digital filtering can assist in providing a steady input signal in noisy environments. Field wiring is made to a removable 20-pin terminal strip.

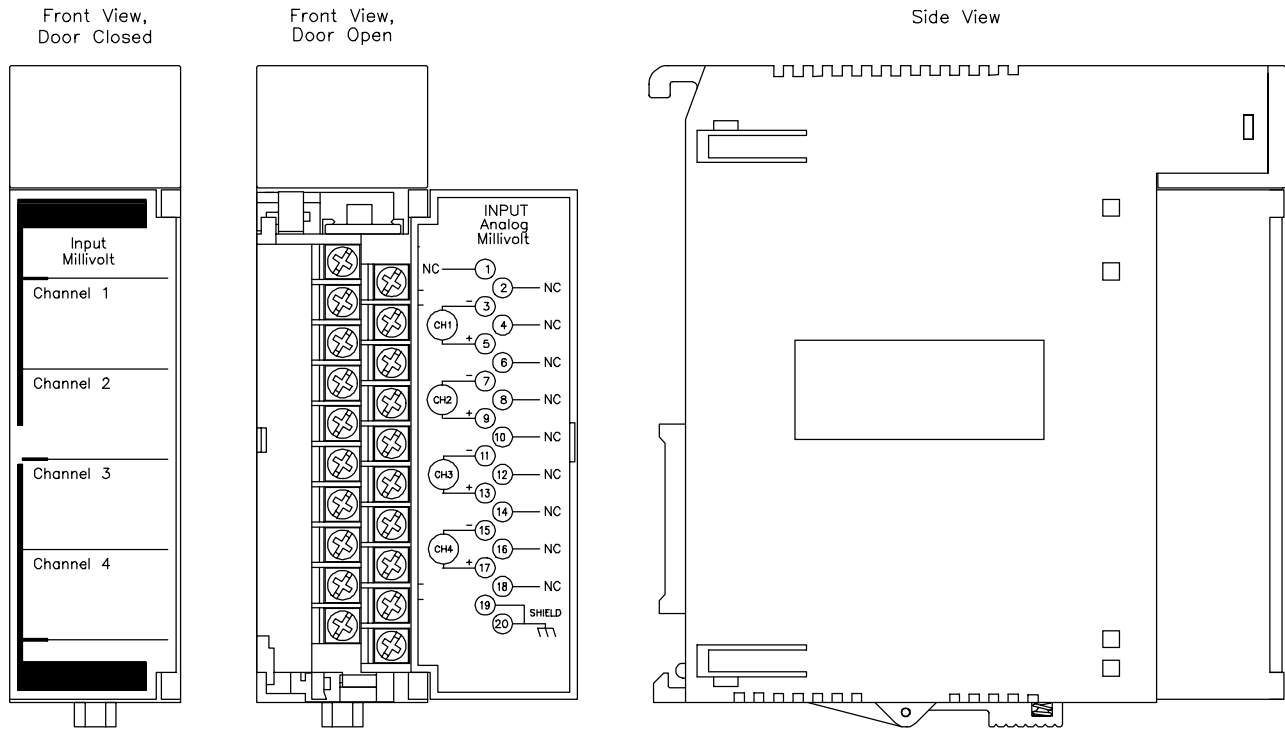

Figure 1 – HE693ADC406 / 409 Module

2 SPECIFICATIONS

Table 1 – HE693ADC406 / 409 Specifications			
Power Consumption	100mA @ 5VDC	Input Impedance	>20 Mohms
Number of Channels	4	Maximum Safe Overload	+/-35VDC
I/O Points Required	4%AI	Common Mode Range	+/-12VDC
Strain Gages Supported	Bridged (Load Cell)	A/D Conversion Type	Integrating
Input Range (Vdc)	+/-25mV, +/-50mV, and +/-100mV	Module Update Rate	35 Channels per second
Resolution	3µV, 6µV, 9µV, respectively	Operating Temperature	0 to 60°C (32 to 140°F)
Accuracy	+/-0.05%	Relative Humidity	5% to 95% non-condensing

3 CONFIGURATION

3.1 Logicmaster 90 Configuration

To reach the Foreign Module Configuration Screen in LM90, perform the following steps:

1. Initiate LM90.
2. Select LogicMaster 90 configuration package (F2).
3. Select/Create a program folder.
4. Select I/O Configuration (F1).
5. Cursor over to the slot containing the module.
6. Select Other (F8). Then select Foreign (F3).

SOFTWARE CONFIGURATION	
SLOT	Catalog #: FOREIGN FOREIGN MODULE
2	
FRGN	
Module ID :	3
%I Ref Adr :	%I0001 Byte 1 : 00000001 Byte 9 : 00
%I Size :	0 Byte 2 : 00000100 Byte 10 : 00
%Q Ref Adr :	%Q0001 Byte 3 : 00 Byte 11 : 00
%Q Size :	0 Byte 4 : 00 Byte 12 : 00
%AI Ref Adr :	%AI001 Byte 5 : 00 Byte 13 : 00
%AI Size :	4 Byte 6 : 00 Byte 14 : 00
%AQ Ref Adr :	%AQ001 Byte 7 : 00 Byte 15 : 00
%AQ Size :	0 Byte 8 : 00 Byte 16 : 00

Figure 2 – Example Configuration

3.2 Configuration Parameters

The necessary configuration parameters are %AI Reference Address, %AI Size, Byte 1, Byte 2 (digital filtering), and Byte 3 (input range).

%AI Reference Address	%AI Size	Byte 1	Byte 2	Byte 3
User Selectable	4	1	0000 through 0111 (see Figure 3)	00: +/-25mVDC 01: +/-50VDC 02: +/-100mVDC

3.3 Digital Filtering

Figure 4 shows the effects of digital filtering (set with Byte 2) on module response to a voltage change. (Indicates % voltage change completed vs. time.)

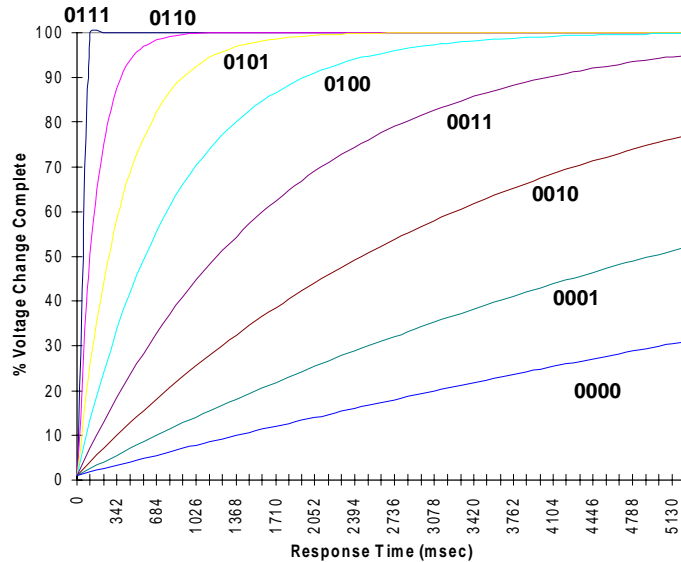

Figure 3 – Digital Response Curve

4 INPUT SCALING

The value of each %AI input varies from -32,000 to +32,000, as the millivolt input ranges from minus full scale (-FS) to positive full scale (+FS). Full scale is either 25mVdc, 50mVdc or 100mVdc as set by configuration. The granularity of the %AI value is 4.

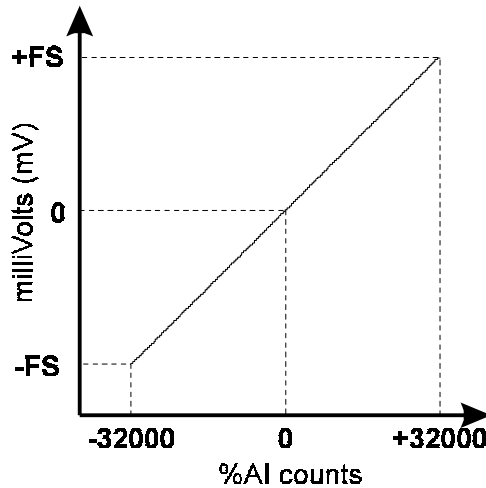
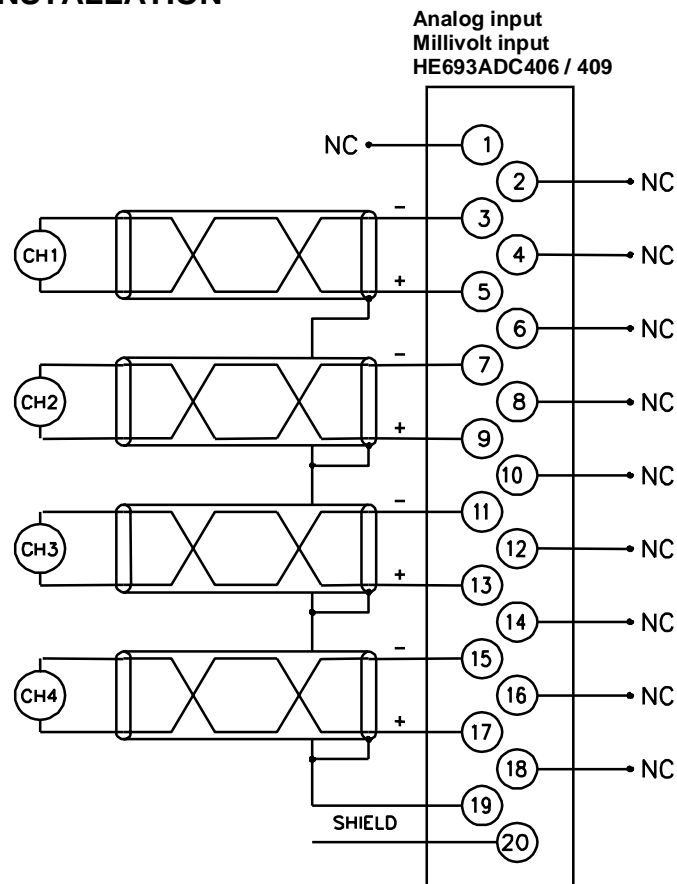

Figure 4 – Input Scaling

5 WIRING / INSTALLATION



5.1 Installation Hints

1. Keep total wire resistance less than 100Ω to maintain rated accuracy.
2. Wiring should be routed in its own conduit.
3. Shielded, twisted pair extension wiring offers best noise immunity.
4. If shielded wiring is used, a good earth ground connection (on one end only) is critical. If shields are connected at the module end, Terminals 19 & 20 may be used as the shield ground point.
5. Short all unused channels to frame ground (See Figure 5 - Pins 19 and 20).

6 TECHNICAL ASSISTANCE

For user manual updates, contact Horner Electric Advanced Products Group, Technical Support Division, at (317) 916-4274 or visit our website at www.heapg.com.