



High Resolution Thermocouple Module

Product Specifications and Installation Data

1 DESCRIPTION

The Horner APG High Resolution Thermocouple Input Module allows thermocouple temperature sensors to be directly connected to the PLC without external signal processing (transducers, transmitters, etc.). All analog and digital processing of the thermocouple signal is performed on the module. This high-resolution module has a resolution of 0.1°C, and temperature values may be reported to the PLC I/O table in 0.5°C, 0.5°F, 0.1°C, or 0.1°F increments. The module features eight thermocouple channels whose temperature values are reported to 8 %AI input registers. There are 16 %I Alarm Bits, one open circuit alarm and one setpoint alarm for each channel. Alarm setpoints are set for each channel through 8 %AQ registers. Open circuit alarm bits for each channel correspond to the first eight successive %I bits, and the alarm setpoints for each channel correspond to the second eight successive %I bits. A feature available on Revision H or later is autodetected external AD592 cold junction compensation. This allows cold junction compensation to be accomplished in a remote isothermal terminal strip, with standard copper wire run from the remote terminal strip to the module.

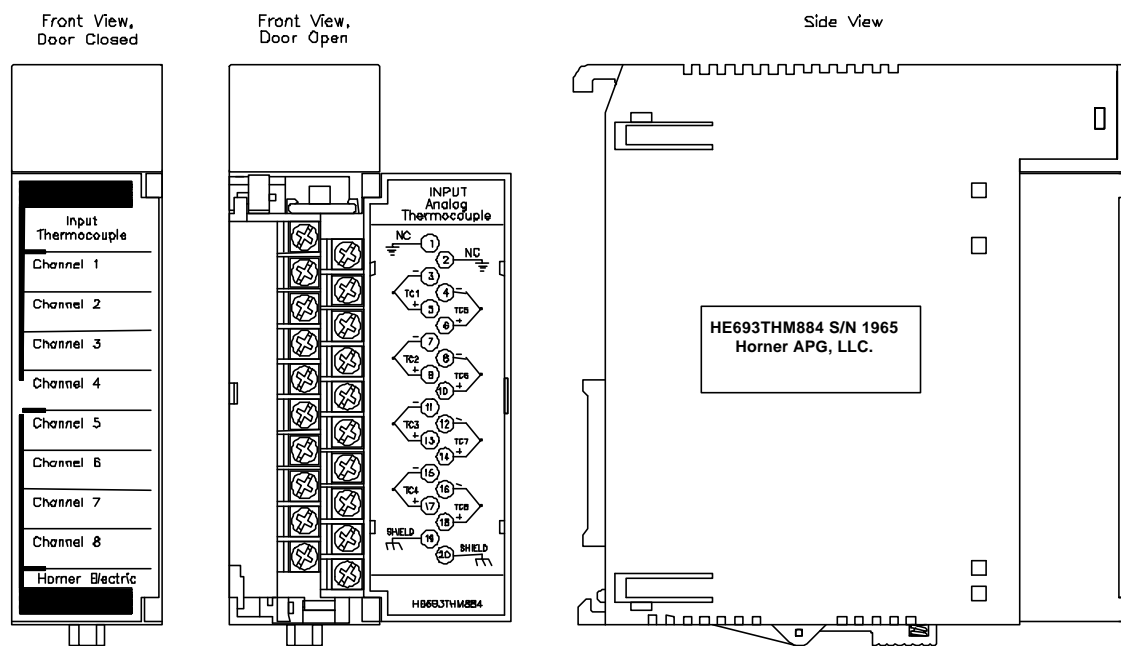

Figure 1 – HE693THM884 Module

2 SPECIFICATIONS

Power Consumption	100mA @ 5VDC			I/O Points Required	8%AI, 8%AQ, 16%I
Number of Channels	8			Input Impedance	>20Mohms
Types Supported	J, K, N, T, E, R, S, B, C, X			Maximum Sustained O/L	+/-35V
Input Range (Temp.)	J: -210 to +760°C	E: -270 to +1000°C	C: 0 to +2320°C	Common Mode Rejection	>100dB
	K: -270 to +1372°C	R: 0 to +1768°C	X: -178 to +982.3°C	A/D Conversion Type	18-Bit Integrating
	N: -270 to +1300°C	S: 0 to +1768°C		A/D Conversion Time	5 ms
	T: -270 to +400°C	B: 0 to +1820°C		Scan Rate	40 channels per second
Resolution	0.1°C			Operating Temperature	0 to 60°C (32 to 140°F)
Accuracy	See Table 2			Relative Humidity	5% to 95% non-condensing

Type	Rated	Range of Rating	Type	Rated	Range of Rating
J	+ / - 1°C	-210 to +760°C	R	+ / - 1°C + / - 2°C	0°C to 1300°C 1300°C to 1768°C
K	+ / - 1°C + / - 2°C	-100 to +1000°C -200 to +1372°C	S	+ / - 1°C + / - 2°C	0°C to 1300°C 1300° to 1768°C
N	+ / - 1°C	-270 to +1300°C	B	+ / - 1°C	0 to +1820°C
T	+ / - 1°C + / - 2°C	-100°C to 400°C -240°C to -100°C	C	+ / - 1°C + / - 2°C + / - 3°C	0°C to 1000°C 1000°C to 1800°C 1800°C to 2320°C
E	+ / - 1°C + / - 2°C	-100°C to 1000°C -200°C to -100°C	X	+ / - 1°C	-178 to +982.3°C

3 CONFIGURATION

SOFTWARE CONFIGURATION		FOREIGN MODULE			
SLOT 2	Catalog #:	FOREIGN			
	FRGN				
	Module ID :	3			
	%I Ref Adr :	%I0001	Byte 1 : 00000001	Byte 9 : 00	
	%I Size :	16	Byte 2 : 00000010	Byte 10 : 00	
	%Q Ref Adr :	%Q0001	Byte 3 : 00	Byte 11 : 00	
	%Q Size :	0	Byte 4 : 00	Byte 12 : 00	
	%AI Ref Adr :	%AI001	Byte 5 : 00	Byte 13 : 00	
	%AI Size :	8	Byte 6 : 00	Byte 14 : 00	
	%AQ Ref Adr :	%AQ001	Byte 7 : 00	Byte 15 : 00	
	%AQ Size :	8	Byte 8 : 00	Byte 16 : 00	

Figure 2 – Foreign Module Configuration

To reach this screen, select I/O Configuration (F1), cursor over to the slot containing the module and select Other (F8), and Foreign (F3).

Byte 1	Byte 2	Byte 3	Byte 4	Bytes 5-12	Bytes 5-12
Smart Module	Digital Filtering	Engr. Units	Up/Downscale Break	T/C Type	T/C Type
1	0000-	00: 0.5°C	00: Upscale Break	00: J	08: C
	0111	01: 0.5°F		01: K	09: X
	(see Chart)	02: 0.1°C		02: N	
		03: 0.1°F	01: Downscale Break	03: T	
		04: E			
		05: R			
				06: S	
				07: B	

The necessary parameters are %I Size, %AI Size, %AQ Size, and Bytes 1-12.

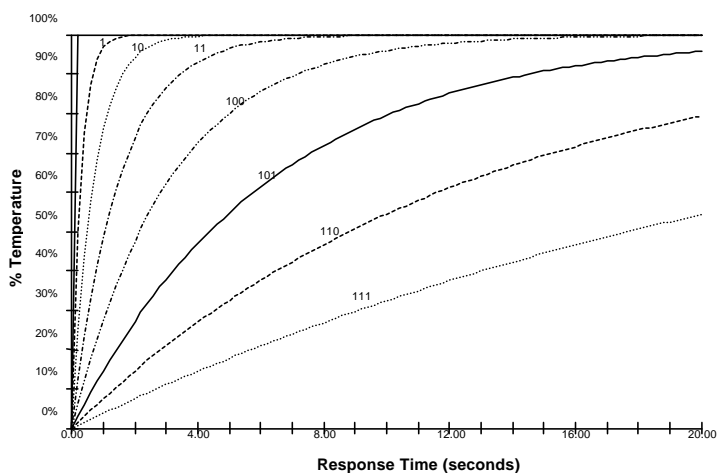

Figure 3 – Digital Filtering

The effect of digital filtering (set with Byte 2) on module response to a temperature change. (% temp change completed vs. time).

4 WIRING

4.1 THM 884 Wiring

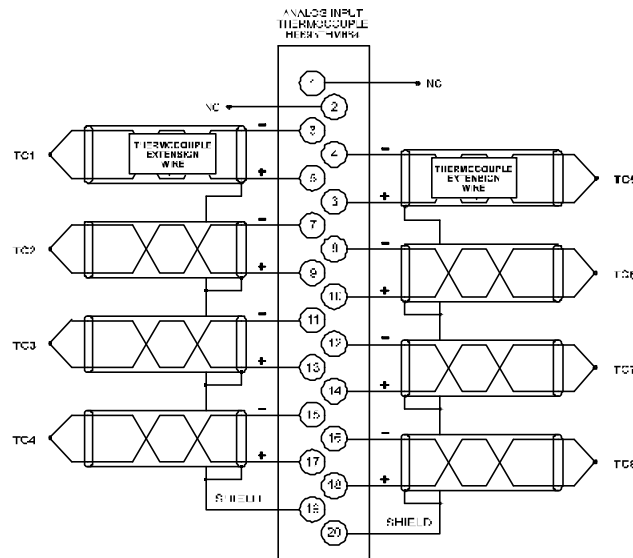

Figure 4 – THM 884 Wiring

4.2 Wiring (Ext. Cold Junction)

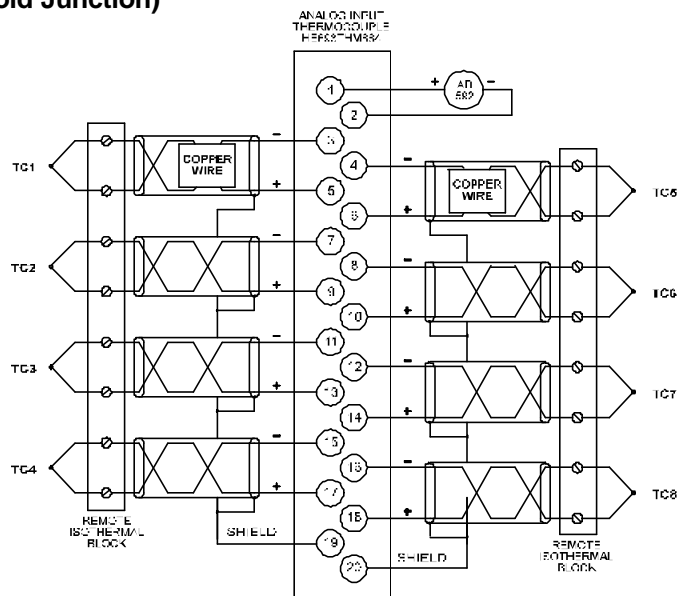

Figure 5 – External Cold Junction Compensation

The THM884 supports remote cold junction compensation. This allows the thermocouple sensors to be connected to a remote terminal strip. Standard shielded copper wiring can then be run between the remote terminal strip and the module terminal strip. The remote terminal strip must be "isothermal" in nature. It should be constructed with a built-in AD592 temperature sensor and even thermal characteristics. The module can detect the presence of an external AD592 temperature sensor and perform cold junction compensation based upon the remote sensor instead of the module's on-board AD592. Horner APG offers an isothermal remote terminal strip (HE693ISOBLK), detailed below.

4.3 Remote Terminal Strip (Optional)

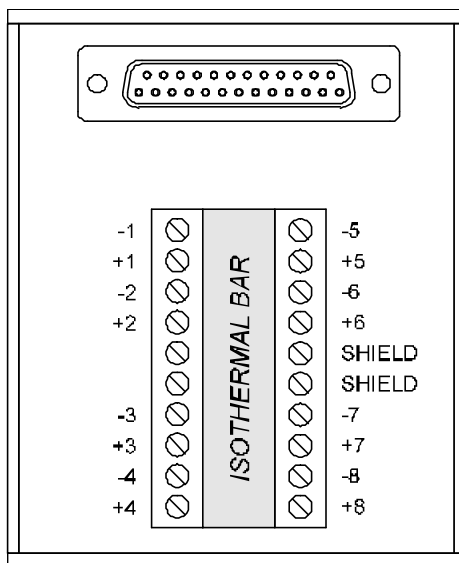

Figure 6 – Remote Terminal Strip (Isothermal Block)

Table 4 – Pinouts					
Isothermal Block Screw Terminal	Isothermal Block DB25 Pin	Module Terminal	Isothermal Block Screw Terminal	Isothermal Block DB25 Pin	Module Terminal
TC-1	3	3	TC-5	7	4
TC+1	16	5	TC+5	20	6
TC-2	4	7	TC-6	8	8
TC+2	17	9	TC+6	21	10
NC	1	2	SHIELD	25	19
NC	14	1	SHIELD	13	20
TC-3	5	11	TC-7	9	12
TC+3	18	13	TC+7	22	14
TC-4	6	15	TC-8	10	16
TC+4	19	17	TC+8	23	18

Remote Terminal Strip (Isothermal Block). The Horner APG HE693ISOBLK is a remote terminal strip which can be used in conjunction with the HE693THM884. It features an isothermal terminal strip, with integrated AD592 temperature sensor. Connections between the remote terminal strip and the THM884 module are accomplished through a DB25 connector. Pinouts for the ISOBLK screw terminals, DB25 connector, and THM884 terminal strip are shown in the table above at right. Cabling constructed by the customer connects the ISOBLK's DB25 female connector and the THM884 module's terminal strip.

5 INSTALLATION

5.1 Installation Hints

Special care must be taken with grounded junction sensors to avoid applying a voltage potential to the thermocouple junction.

Extension wire of the proper Thermocouple type must be used. Keep total wire resistance less than 100 Ω to maintain rated accuracy.

Extension wiring should be routed in its own conduit. Shielded, twisted pair extension wiring offers best noise immunity.

If shielded wiring is used, a good earth ground connection is critical. Terminals 19 and/or 20 may be used as the shield ground point.

Short all unused channels to frame ground. (See Figure 5, pins 19 and 20.)

6 TECHNICAL ASSISTANCE

For manual updates and assistance, contact Technical Support at the following locations:

North America:

(317) 916-4274
www.heapg.com

Europe:

(+) 353-21-4321-266
www.horner-apg.com