



SmartMod RTD Input Module HE359RTD100 0.1C or 0.1ohm Resolution



1 Specifications

	RTD100		RTD100
Number of Channels	4	Conversion Time (PLC Update Rate)	Determined by Communications w/OCS
Input Ranges	RTD Pt-100, Ni-100, Pt-1000, & Ni-1000, 0-2000ohm, 0-500ohm (PT, .00385)	Terminal Type	Screw Type, Removable
Resolution	0.1C or 0.1ohm	Storage Temp.	-40° to 85° Celsius
RTD Excitation Current	350microamp, typical	Operating Temp.	-10° to 60° Celsius
Accuracy	+/-0.1% F.S.	Relative Humidity	5 to 95% Non-condensing
External Power Supply Voltage	10-30Vdc	Dimensions WxHxD	17.5mm x 100mm x 120mm 0.69" x 3.94" x 4.72"
Required Power (Steady State)	30mA @ 24Vdc, typical	Weight	150g (6 oz.)
Required Power (Inrush)	Negligible	Communications	Modbus/RTU (binary) RS-485 half duplex
Isolation	2000Vac for 60 seconds (Input/Power & Input/Comms)	Factory Default Communications Parameters	38400 baud, N, 8, 1, no h/s Default Modbus ID 1
CE & UL Compliance	See Compliance Table at http://www.heapg.com/Pages/TechSupport/ProductCert.html		
		Supported Modbus Commands	1,2,3,4,5,6,8, 15,16

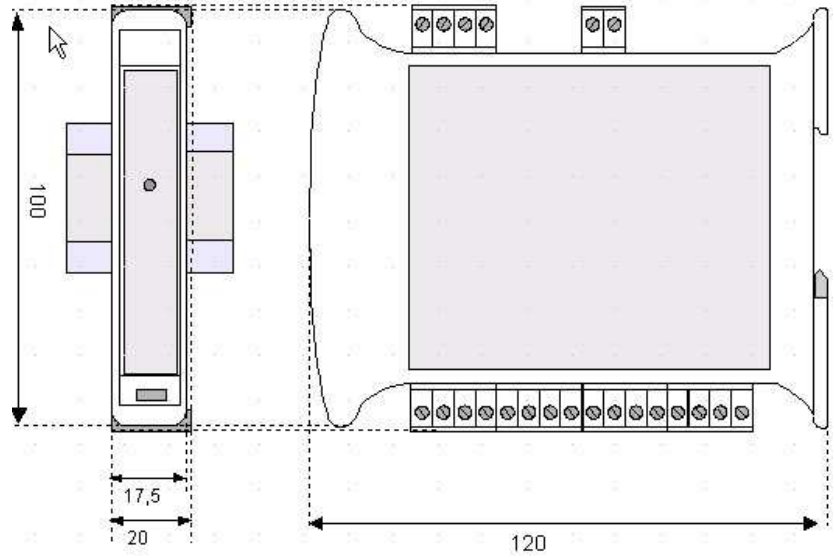

Dimensions in inches are 0.69"W x 3.95"H x 4.72"D
Note: Number of I/O terminal connections vary from model to model

2 Wiring - I/O

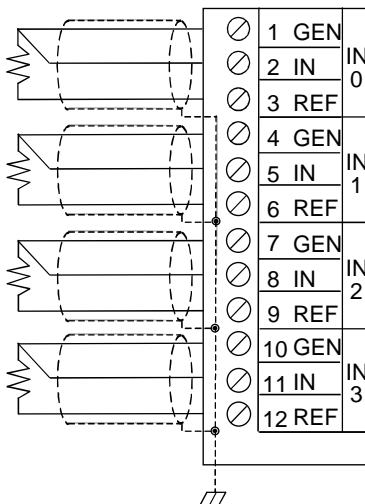
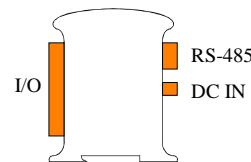

Pin #	RTD100		Pin #	RTD100	
1	GEN	IN 0	7	GEN	IN 2
2	IN		8	IN	
3	REF		9	REF	
4	GEN	IN 1	10	GEN	IN 3
5	IN		11	IN	
6	REF		12	REF	

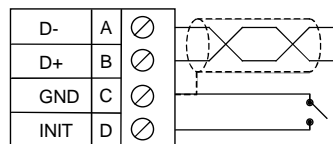

Wiring RS-485

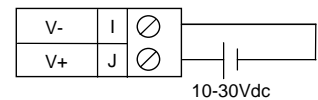

Wiring DC IN

Notes:

Both ends of the RS-485 network should be terminated with a 100ohm, 1/4W, 1% resistor. Many OCS controllers feature dip switches or jumpers which enable appropriate termination if the OCS is located on a network end.

3 Init Default Setup

Communication parameters will be set to INIT default after performing the procedure:

1. Install jumper between INIT and GND terminals of the RS-485 port.
2. Apply power to Smartmod unit.
3. Read parameter words to see current parameters.
4. Write changes if necessary.

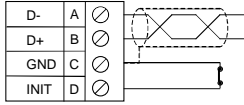

The INIT Default RS485 Settings Are:

Modbus ID = 1
 Baud rate = 9600
 Parity = None
 Stop Bits = 1
 Data Bits = 8
 No handshake

Note: There are 2 types of default settings possible:
 1. Factory default as described in section 1 (Specifications)
 2. Default after INIT as described in section 3 (INIT Default Setup)

4 Configuration DATA

SmartMod Configuration settings are mapped into Modbus Register space. This configuration data may be modified with any Modbus/RTU Master device. For convenience, Horner APG has developed a variety of Cscape application files which allow an OCS (Xle, NX, LX, QX) to act as a SmartMod configurator. Initial configuration of SmartMod module should be done on an individual basis, since all modules come from the factory with a default Modbus ID of 1. Once each module on the network has its own unique Modbus ID, further configuration adjustments can be made with the entire network powered.

All configuration parameters listed below (except 40012 Channel Enable) are stored in EPROM. That means they should not be constantly rewritten.

Configuration Parameters – Registers 40001 through 40013				
Modbus Register	Description	Min	Max	Default
40001-40005	Reserved			
40006	Communications Parameters	See Table		38.4kbaud, N, 8, 1, RTU Mode
40007	Modbus ID	1	255	1
40008	Rx/Tx Delay (in 2mS steps)	0	255	0mS
40009	Watchdog Timer (in 0.5s steps)	0	255	10 (5s)
40010	Modbus Coil Data	Not Configuration Data – See I/O Data		
40011	Input Type	See Table		23 (RTD Pt-100 Type)
40012	Channel Enable	See Table		255 (All Channels enabled)
40013	Reserved			

Register 40006 (Communications Parameters) Bit Definition							
Bits 7-15	Bit 6	Bit 5	Bit 4	Bit 3	Bit 2	Bit 1	Bit 0
Unused	Mode	Parity		Data Bits	Baud Rate		
	0 = ASCII Mode	Value	Meaning	0 = 7 Data Bits	Value	Meaning	
		0	Mark		0	1200 baud	
		1	Even		1	2400 baud	
	1 = RTU Mode	2	Odd	1 = 8 Data Bits	2	4800 baud	
		3	Space		3	9600 baud	
					4	19200 baud	
					5-7	38400 baud	

Register 40011 (Input Type) Value Definition	
Value	Input Type
7	0-2000ohm Resistance
8	0-500ohm Resistance
23	RTD Pt-100 Type
24	RTD Ni-100 Type
25	RTD Pt-1000 Type
26	RTD Ni-1000 Type

Register 40012 (Channel Enable) Bit Definition				
Bit 4-15	Bit 3	Bit 2	Bit 1	Bit 0
Unused	Input 3	Input 2	Input 1	Input 0
0 = Disable Input				
1 = Enable Input				

5 Input/Output DATA

SmartMod Analog I/O utilizes both Modbus Registers (40001-40030) and Coils (1-11). It is possible to access all data using Registers only, because the Coils can be accessed through Register 40010.

The following tables lists all Modbus I/O data available.

I/O Register Data (Registers 40014-40022)					
Modbus Register	Description	Access	Minimum	Maximum	Units
40010	Mirror of Coil Data	Read/Write	n/a	n/a	n/a
40014	Cold Junction Temperature	Read-only	-1000	6000	0.01 degrees C
40015	Input 0	Read-only	Depends on Input Type	Depends on Input Type	0.1C or 0.1 ohm
40016	Input 1	Read-only			
40017	Input 2	Read-only			
40018	Input 3	Read-only			
40019	Input 4	Read-only			
40020	Input 5	Read-only			
40021	Input 6	Read-only			
40022	Input 7	Read-only			

Modbus Coil	Description	Access	Watchdog Event & Power-up Event Operation
00001	Open Detect Input 0	Read/Write	If Coil 9 (Watchdog Enabled) is set, Coil 10 (Watchdog Event) will set if the Watchdog Timeout value is exceeded. The Watchdog Timeout value is set in Register 40009. When set, Coil 10 can be reset by the controller when normal communications resumes. The Power-up Event (Coil 11) is set every time the power is applied. It can be cleared by the controller if desired.
00002	Open Detect Input 1	Read/Write	
00003	Open Detect Input 2	Read/Write	
00004	Open Detect Input 3	Read/Write	
00005	Open Detect Input 4	Read/Write	
00006	Open Detect Input 5	Read/Write	
00007	Open Detect Input 6	Read/Write	
00008	Open Detect Input 7	Read/Write	
00009	Watchdog Enabled	Read/Write	
00010	Watchdog Event	Read/Write	
00011	Power-up Event	Read/Write	

RTD Sensor Temperature Ranges		
RTD Sensor Type	Minimum Temperature	Maximum Temperature
Pt-100	-200 degrees C	+850 degrees C
Ni-100	-80 degrees C	+180 degrees C
Pt-1000	-200 degrees C	+200 degrees C
Ni-1000	-60 degrees C	+150 degrees C

6 Installation / safety

Warning: Remove power from the OCS controller, CAN port, and any peripheral equipment connected to this local system before adding or replacing this or any module.

- a. All applicable codes and standards should be followed in the installation of this product.
- b. Shielded, twisted-pair wiring should be used for best performance.
- c. Shields may be terminated at the module terminal strip.
- d. In severe applications, shields should be tied directly to the ground block within the panel.
- e. Use the following wire type or equivalent: Belden 8441.

For detailed installation and a handy checklist that covers panel box layout requirements and minimum clearances, refer to the hardware manual of the controller you are using.

When found on the product, the following symbols specify:



7 Technical Support

Technical Support at the following locations:

North America: Tel: 317 916-4274 Fax: 317 639-4279 Web: http://www.heapg.com Email: techspt@heapg.com	Europe: Tel: +353-21-4321266 Fax: +353-21-4321826 Web: http://www.horner-apg.com Email: tech.support@horner-apg.com
--	---

No part of this publication may be reproduced without the prior agreement and written permission of Horner APG, Inc. Information in this document is subject to change without notice.