



Ethernet Communications Module

HE800ETN200 / HE800ETN300

HE-ETN200* / HE-ETN300*



* Denotes plastic case

This product has a detailed supplement SUP0740.

1 Description

The SmartStack Ethernet Module (ETN200 / ETN300) gives the Horner OCS family of controllers the capability to communicate over Ethernet. Some controller models (such as NX221, NX251, QX351, QX451, QX551, QX651, QX751 and XL6e) have built-in ETN200 / ETN300 capabilities while other models (such as OCS100, OCS200, OCS110, OCS210, OCS250, RCS 116, RCS210 and RCS250) require a user-installed ETN200 / ETN300 SmartStack module. In either case, the ETN200 / ETN300 supports the following application protocols:

Table 1 – Protocol / Features			
Protocol / Feature	Protocol / Feature Description	ETN200	ETN300
ICMP Ping	Internet Control Message Protocol	√	√
EGD (Peer)	GE Fanuc Ethernet Global Data	√	√
SRTP Server	GE Fanuc Service Request Transfer Protocol	√	√
Modbus TCP Slave	Modbus over Ethernet	√	√
CsCAN TCP Server	Horner APG CsCAN over Ethernet	√	√
Ethernet / IP Server	ODVA CIP over Ethernet	√	√
FTP Server*	File Transfer Protocol	√	√
HTTP Server*	HyperText Transfer Protocol (Web Server)	√	√
SMTP**	Simple Mail Transfer Protocol (Email)		√
Half / Full Duplex	Auto-Negotiated Ethernet Mode	√	√
10 / 100 Mbps	Auto-Negotiated Ethernet Speed	√	√
Extended Registers	Access to %R2049-%R9999		√

* FTP & HTTP protocols are supported only by OCS Models with built-in Ethernet and Compact Flash/MicroSD, such as OCS451, OCS551, OCS651, NX221, NX251, QX351, QX451, QX551, QX651, QX751 and XL6e.

SMTP protocol is supported by OCSes that have inbuilt Ethernet port like QX series, NX series and XL6e.**

2 Specifications

Table 2 - ETN 200 / ETN 300 Specifications	
General	
Ethernet Speeds	10 BaseT Ethernet (10 Mbps) 100 BaseTx Fast Ethernet (100 Mbps)
Ethernet Modes	Half or Full Duplex
Ethernet Auto-Negotiation	Both 10 / 100 Mbps and Half / Full Duplex
Port (QX351, XL6e Only)	Auto MDI/MDI-X
Ethernet Connector Type	Shielded RJ-45
Ethernet Cable Type Recommendation	CAT5 (or better) UTP
Application Protocols	
ICMP	Ping Only
CsCAN TCP Server	Maximum Connections = 8 Maximum Exchanges = 127
EGD (Ethernet Global Data)	Maximum Data Bytes per Exchange = 1,400
SRTP Server	Maximum Connections = 16
Modbus TCP Slave	Maximum Connections = 16
Ethernet / IP Server	Maximum Connections = 2
FTP Server	Maximum Connections = 4
HTTP Server	Maximum Connections = 1

Ethernet Module configuration is done through Cscape Programming Software. Figure 1 illustrates an example of a network containing ETN200 and ETN300 Ethernet Modules.

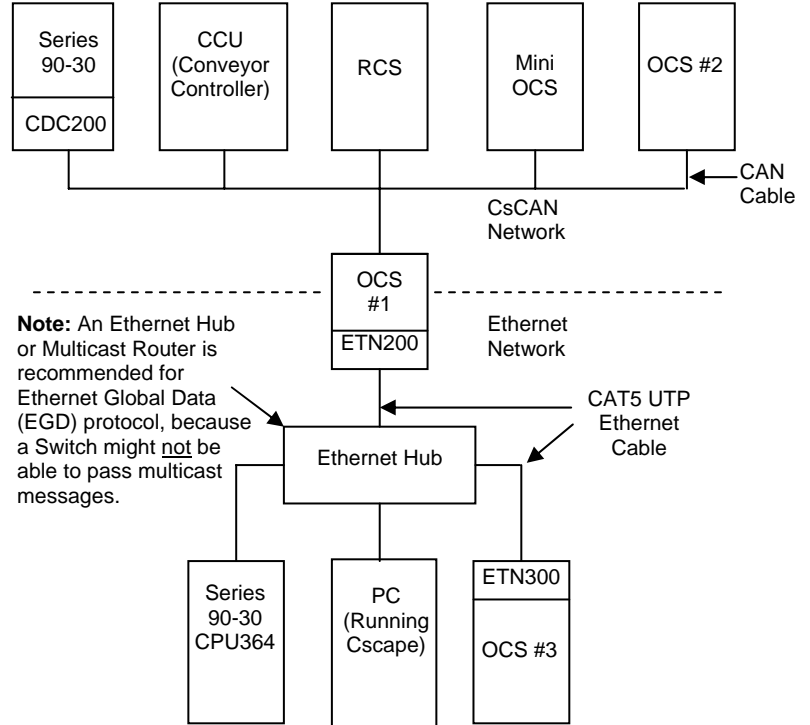

Figure 1 – Example of an Ethernet Network

3 Connectors

Note: If using a controller with built-in Ethernet, refer to the controller's user manual. See [Additional References](#) in this document.

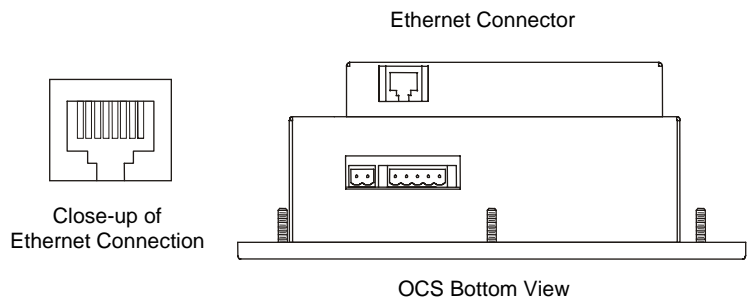

Figure 2– Ethernet Connector on the ETN SmartStack Module

Note: The ETN200 / ETN300 must be installed in the first slot.

4 Ethernet System Requirements and Interoperability

- PC running Cscape Programming Software Version 7.0c or later (for configuration)
- OCS controller with built-in or user-installed ETN200 or ETN300 Ethernet Module
- FTP & HTTP protocols supported only by OCS Models with built-in Ethernet and Compact Flash/MicroSD.

The *server* protocols supported by the ETN200 and ETN300 SmartStack Ethernet Modules have been tested for interoperability with Cscape and several 3rd party *client* software packages, as shown in the following Table.

Client Software Package		Ethernet Module Server Protocol					
Name	Version	CsCAN	SRTP	Modbus	EIP	FTP	HTTP
Cscape Programming Software	7.0c	√					
GE Proficy View *	5.50.3655		√				
GE Fanuc Cimplicity HMI	3.2		√				
GE Fanuc Cimplicity PE	5.0		√				
	6.1		√	√			
KEPware OPC / DDE Server	4.84.227		√	√			
Pyramid EIP Scanner Demo	3.51				√		
Microsoft Internet Explorer	5.50.4522					√	√
	6.0.2900					√	√
SmartFTP	1.5.990					√	
Mozilla Firefox	1.0.7						√

* When selecting the PLC Access Driver for SRTP mode using Proficy View software, be sure to select *GE Fanuc TCP/IP*.

5 Installation / Safety

Warning: Remove power from the OCS controller, CAN port, and any peripheral equipment connected to this local system before adding or replacing this or any module.

Use the following wire type or equivalent:

- Belden 8917
- 16 AWG or larger

For detailed installation and a handy checklist that covers panel box layout requirements and minimum clearances, refer to the hardware manual of the controller you are using. (See the Additional References section in this document.)

When found on the product, the following symbols specify:



This equipment is suitable for use in Class I, Division 2, Groups A, B, C and D or Non-hazardous locations only

WARNING – EXPLOSION HAZARD – Do not disconnect equipment unless power has been switched off or the area is known to be non-hazardous.
AVERTISSEMENT - RISQUE D'EXPLOSION - AVANT DE DECONNECTER L'EQUIPMENT, COUPER LE COURANT OU S'ASSURER QUE L'EMPLACEMENT EST DESIGNÉ NON DANGEREUX.

WARNING: To avoid the risk of electric shock or burns, always connect the safety (or earth) ground before making any other connections.

WARNING: To reduce the risk of fire, electrical shock, or physical injury it is strongly recommended to fuse the voltage measurement inputs. Be sure to locate fuses as close to the source as possible.

WARNING: Replace fuse with the same type and rating to provide protection against risk of fire and shock hazards.

WARNING: In the event of repeated failure, do not replace the fuse again as a repeated failure indicates a defective condition that will not clear by replacing the fuse.

WARNING – EXPLOSION HAZARD – Substitution of components may impair suitability for Class I, Division 2.
AVERTISSEMENT - RISQUE D'EXPLOSION - LA SUBSTITUTION DE COMPOSANTS PEUT RENDRE CE MATERIAL INACCEPTABLE POUR LES EMBLEMES DE CLASSE 1, DIVISION 2.
WARNING: Only qualified electrical personnel familiar with the construction and operation of this equipment and the hazards involved should install, adjust, operate, or service this equipment. Read and understand this manual and other applicable manuals in their entirety before proceeding. Failure to observe this precaution could result in severe bodily injury or loss of life.

- All applicable codes and standards need to be followed in the installation of this product.

Adhere to the following safety precautions whenever any type of connection is made to the module:

- Connect the safety (earth) ground on the power connector first before making any other connections.
- When connecting to electric circuits or pulse-initiating equipment, open their related breakers.
- Do not make connections to live power lines.
- Make connections to the module first; then connect to the circuit to be monitored.
- Route power wires in a safe manner in accordance with good practice and local codes.
- Wear proper personal protective equipment including safety glasses and insulated gloves when making connections to power circuits.
- Ensure hands, shoes, and floors are dry before making any connection to a power line.
- Make sure the unit is turned OFF before making connection to terminals.
- Make sure all circuits are de-energized before making connections.
- Before each use, inspect all cables for breaks or cracks in the insulation. Replace immediately if defective.
- Use Copper Conductors in Field Wiring Only, 60/75° C

6 Additional References

The following information serves as a *general* listing of Horner controller products and other references of interest and their corresponding manual numbers. Visit our website listed in the Technical Support section to obtain user documentation and updates.

Note: This list is not intended for users to determine which products are appropriate for their application; controller products differ in the features that they support. If assistance is required, see the **Technical Support** section in this document.

Controller	Manual Number
QX Series (e.g., HE-QXxxx)	MAN0798
NX Series (e.g., HE-NXxxx)	MAN0781
LX Series (e.g., LX-xxx; also covers RCS116)	MAN0755
QX351	MAN0892
Color Touch OCS (e.g., OCSxxx)	MAN0465
QX751	MAN0890
XL6e	MAN0883
OCS (Operator Control Station) (e.g., OCS1xx / 2xx; Graphic OCS250)	MAN0227
Remote Control Station (e.g., RCS2x0)	
MiniOCS (e.g., HE500OCSxxx, HE500RCSxxx)	MAN0305
Other Useful References	
CAN Networks	MAN0799
Cscape Programming and Reference	MAN0313
Wiring Accessories and Spare Parts Manual	MAN0347
DeviceNet™ Implementation	SUP0326
Wiring Accessories and Spare Parts Manual	MAN0347
SmartStack Ethernet Module Supplement	SUP0740

7 Technical Support

For assistance and manual updates, contact Technical Support at the following locations:

North America: Tel: 317 916-4274 Fax: 317 639-4279 Web: http://www.heapg.com Email: techsppt@heapg.com	Europe: Tel: +353-21-4321266 Fax: +353-21-4321826 Web: http://www.horner-apg.com Email: tech.support@horner-apg.com
--	---

SmartStack is a trademark of Horner APG, LLC.

No part of this publication may be reproduced without the prior agreement and written permission of Horner APG, Inc. Information in this document is subject to change without notice.