

SmartStix™

User Manual for the Profibus Versions (HE450 or HE459) of:

DQM601 DQM606
 DQM701 DQM706
 DIM610 DIM710
 DIQ811 DIQ816
 DQM602

Remote I/O

For Electronic Information including the GSD File, see www.SmartStix.com.

05 August 2004

MAN0520-09

Cscape, SmartStix and CsCAN are trademarks of Horner APG. Profibus is a registered trademark of Siemens. This information is subject to change without notice.

1 Technical Support

For user manual updates and technical assistance, contact Technical Support:
 North America: (317) 916-4274 Europe: (+) 353-21-4321-266
 or visit our website at www.heapg.com or visit our website at www.horner-apg.com.

2 Installation / Safety

- All applicable codes and standards need to be followed in the installation of this product.
- For I/O wiring (discrete), use the following wire type or equivalent: Belden 9918, 18 AWG or larger.
- For detailed installation information, refer to www.profibus.org.
- This product has a Programming Reference (SUP0552).



Warning: Consult user documentation.



Warning: Electrical Shock Hazard.

3 Model Numbers

Model Prefix	Description
HE450	Profibus model with non-removable terminal strip
HE459	Profibus model with removable terminal strip
Long or Short Dimension	Description
DIM610 (Short)	16 DC Inputs (24VDC, positive/negative logic)
DIM710 (Long)	32 DC Inputs (24VDC, positive/negative logic)
DQM601 / 606* (Short)	16 DC Outputs (24VDC, negative logic, 0.5A) (Note: If using DQM601 with a non-removable terminal strip, the output rating is 0.1A.) (* DQM606 uses positive logic.)
DQM701 / 706** (Long)	32 DC Outputs (24VDC, negative logic, 0.5A) (Note: If using DQM701 with a non-removable terminal strip, the output rating is 0.1A.) (** DQM706 uses positive logic.)
DQM602 (Long)	16 Relay Outputs (250VAC, 30VDC, 2.0A)
DIQ811 / 816*** (Long)	16 DC Inputs (24VDC, positive/negative logic) 16 DC Outputs (24VDC, negative logic, 0.5A) (Note: If using DIQ811 with a non-removable terminal strip, the output rating is 0.1A.) (*** DIQ816 uses positive logic.)

4 Dimensions

a. Long Dimensions

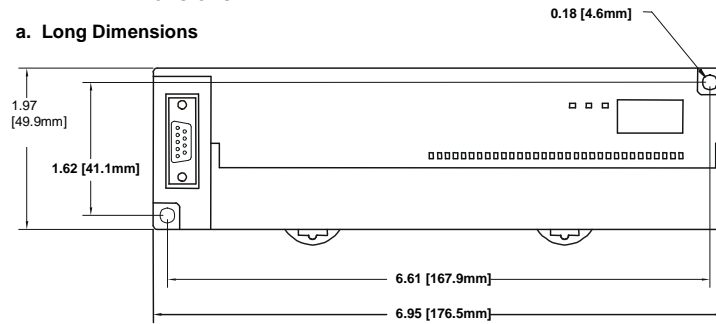

b. Short Dimensions

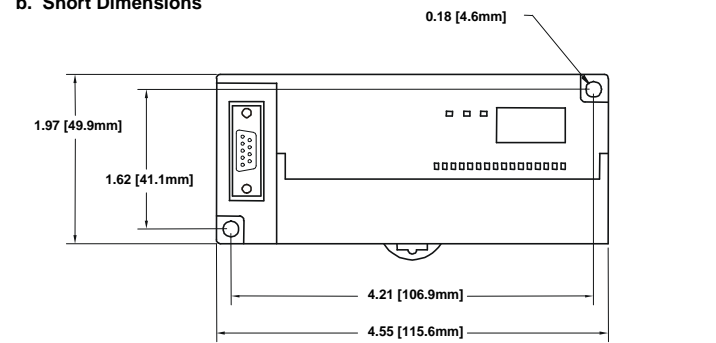

c. Terminal Strips

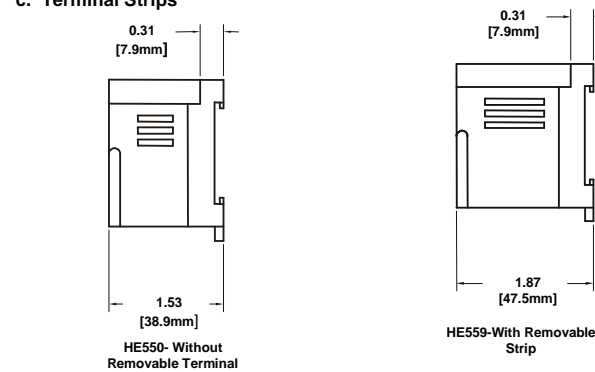

5 General Specifications

General Specifications			
Storage Temperature	-25° to 70° C	Operating and Storage Humidity	5 to 95% Non-condensing
Operating Temperature	0° to 55° C	Pollution degree	2 or lower
Atmosphere	Free from corrosive gases and excessive dust	Cooling method	Self-cooling
Vibration			
Occasional Vibration			
Frequency	Acceleration	Amplitude	Sweep Count
10 ≤ f < 57 Hz	-	0.075 mm	10 times in each direction for X,Y,Z
57 ≤ f ≤ 150 Hz	9.8 m/s ² {1G}	-	-
Continuous Vibration			
Frequency	Acceleration	Amplitude	Sweep Count
10 ≤ f < 57 Hz	-	0.035 mm	10 times in each direction for X,Y,Z
57 ≤ f ≤ 150 Hz	4.9 m/s ² {0.5G}	-	-
Shocks			
Maximum shock acceleration	147 m/s ² {15G}		
Duration Time	11 ms.		
Pulse Wave	Half sine wave pulse (3 times in each of X, Y, Z directions)		

Noise Immunity				
Square wave impulse noise	AC: ± 1,500VDC DC: ± 900VDC			
Electrostatic Discharge	Voltage: 4kV (contact discharge)			
Radiated electromagnetic field	27 – 500MHz, 10V/m			
Fast Transient Burst Noise	Severity level	All power modules	Digital I/Os (Ue ≥ 24V)	Digital I/Os (Ue < 24 V) Analog I/Os Communication I/Os
	Voltage	2 kV	1 kV	0.25 kV

6 Network Cable

For detailed network information, refer to www.profibus.org.
 a. A SmartStix module uses a 9-pin D-sub plug connector for its DP port. The pin assignment of the plug connector and the wiring are shown below.

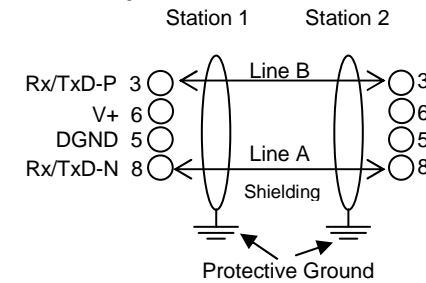

b. It is necessary to terminate both ends of the network. Both terminations must have power to them to insure proper operation of the network. The following diagram illustrates the correct connection for the termination resistors. The diagram is for illustrative purposes only.
Note: Cabling and connectors need to be PTO-approved to achieve the desired performance results.

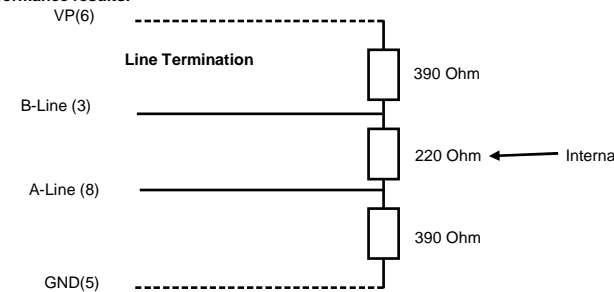

c. The shield braiding (and if present, the shield foil) must be connected to protective ground on both sides and must have good conductivity via shield clamps that cover as large an area as possible. In addition, it is recommended that the data lines be kept separate from all high-voltage cables.

7 Address Switches

Profibus addresses are set using the decimal number system from 1 to 99. Set a unique Network ID by inserting a small Phillips screwdriver into the two identical switches.

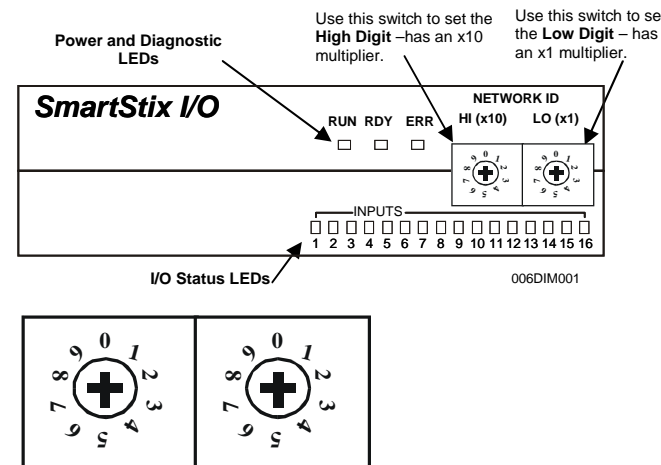

8 LEDs

LED	MEANING
RUN	Displays the status of the power
RDY	Displays the communication status of the communication module
ERR	Displays abnormal condition of communication module

9 SmartStix Modules

a. DIM610: 16 DC IN, Positive / Negative Logic

DIM610 Specifications			
Number of input points	16	OFF to ON Response	0 - 3ms. or less
Rated Input Current	7mA	ON to OFF Response	0 - 3ms. or less
ON Voltage Level	19VDC or less	Common Terminal	16 points / COM
OFF Voltage Level	6VDC or less	Operating Indicator	LED turns on during ON state of input
Input Characteristics	Bidirectional	External Connections	Terminal block connector (M3 x 6 screws)
Isolation Method	Photo Coupler	Altitude for use	Up to 2,000m
Internal power Consumption (mA)	200mA	Weight	5.6 oz. (159 g)

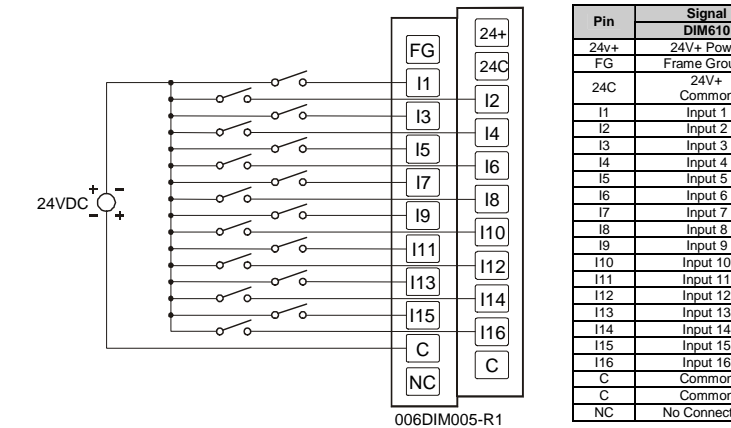

b. DIM710: 32VDC IN, Positive / Negative Logic

DIM710 INPUTS			
Number of input points	32	OFF to ON Response	0 - 3ms. or less
Rated Input Current	7mA	ON to OFF Response	0 - 3ms. or less
ON Voltage Level	19VDC or less	Common Terminal	16 points / COM
OFF Voltage Level	6VDC or less	Operating Indicator	LED turns on during ON state of input
Input Characteristics	Bidirectional	External Connections	Terminal block connector (M3 x 6 screws)
Isolation Method	Photo Coupler	Weight	8.36oz. (237 g)
Internal power Consumption (mA)	300		

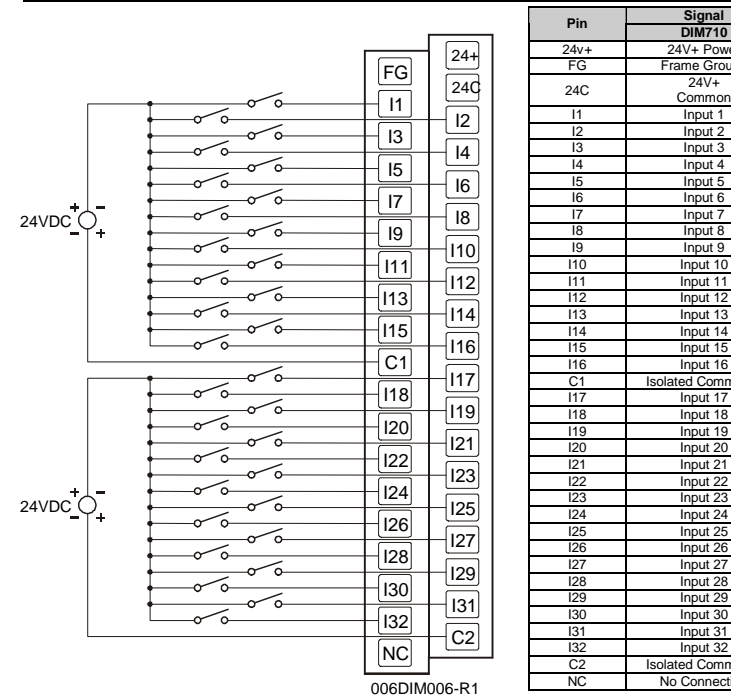

c. **DQM601: 16 DC OUT, Negative Logic**
DQM606: 16 DC OUT, Positive Logic

DQM601 / DQM606 Outputs				
Number of output points	16	External Power Supply	Voltage	24VDC ± 10% (ripple voltage: 4Vp-p or less)
Commons per Module	1		Current	30mA (TYP, All points ON)
Operating Voltage	24VDC	OFF to ON Response	0-3ms. or less	
Rated Load Voltage	24VDC	ON to OFF Response	0-3ms. or less	
Max. Load Current per channel	DQM 601A	Output Type	DQM 601	Sinking
	•DQM601B •DQM606		DQM 606	Sourcing
OFF Leakage Current	0.1mA or less	Common Method	16 points / COM	
Max. Inrush Current per channel	DQM 601	Operating Indicator	LED turns on during ON state of output	
	DQM 606		External connections	Terminal block connector (M3 x 6 screws)
Maximum Voltage Drop during ON circuit	1.5VDC (0.5A)	Isolation methods	Photo Coupler	
Internal power Consumption (mA)	280	Weight	DQM601	5.6 oz. (160g)
			DQM606	6.7oz. (189g)

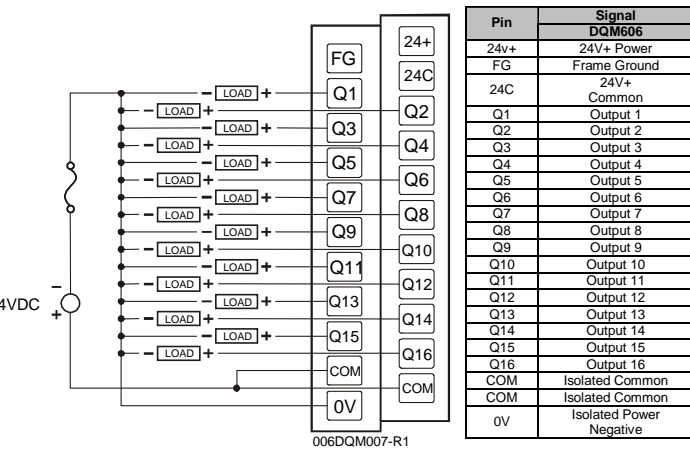
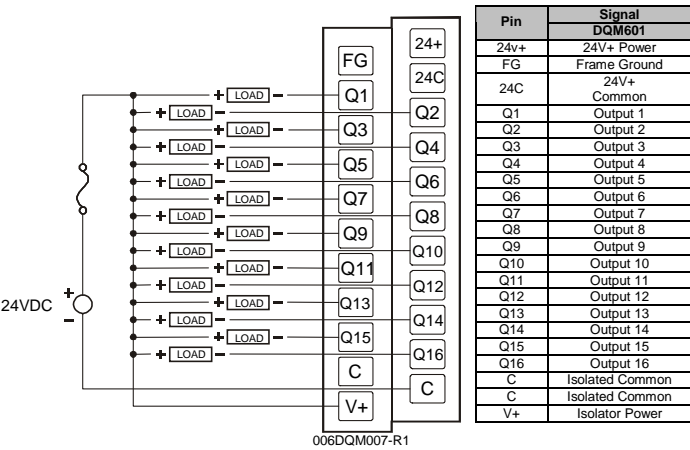

d. **DQM701: 32 DC OUT, Negative Logic**
DQM706: 32 DC OUT, Positive Logic

DQM701 / 706 Outputs				
Number of output points	32	External Power Supply	Voltage	24VDC ± 10% (ripple voltage: 4Vp-p or less)
Commons per Module	2		Current	30mA (TYP, All points ON)
Operating Voltage	24VDC	OFF to ON Response	0-3ms. or less	
Rated Load Voltage	24VDC	ON to OFF Response	0-3ms. or less	
Maximum Load Current per channel	0.1A Max. per output; 2A per common	Output Type	DQM 701	Sinking
			DQM 706	Sourcing



DQM701 / 706 Outputs continued					
Max. Inrush Current per channel	DQM 701	0.4A, 10ms.	Operating Indicator	LED turns on during ON state of output	
	DQM 706	1A, 10ms	External connections	Terminal block connector (M3 x 6 screws)	
OFF Leakage Current	0.1mA or less		Common Method	16 points / COM	
Maximum Voltage Drop during ON circuit	1.5VDC(0.5A)		Isolation methods	Photo Coupler	
Internal power Consumption (mA)	DQM701	380	Weight	DQM701	8.9oz. (255g)
	DQM706	320		DQM706	10.0oz. (285g)

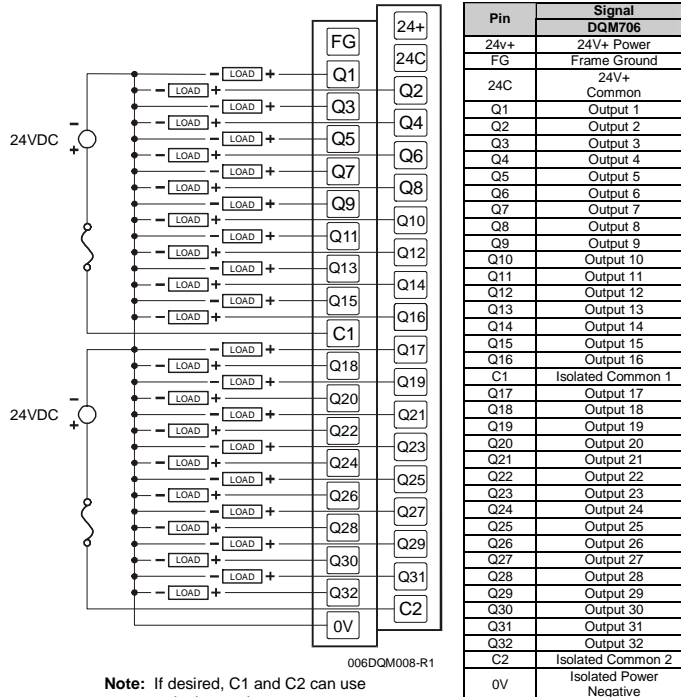
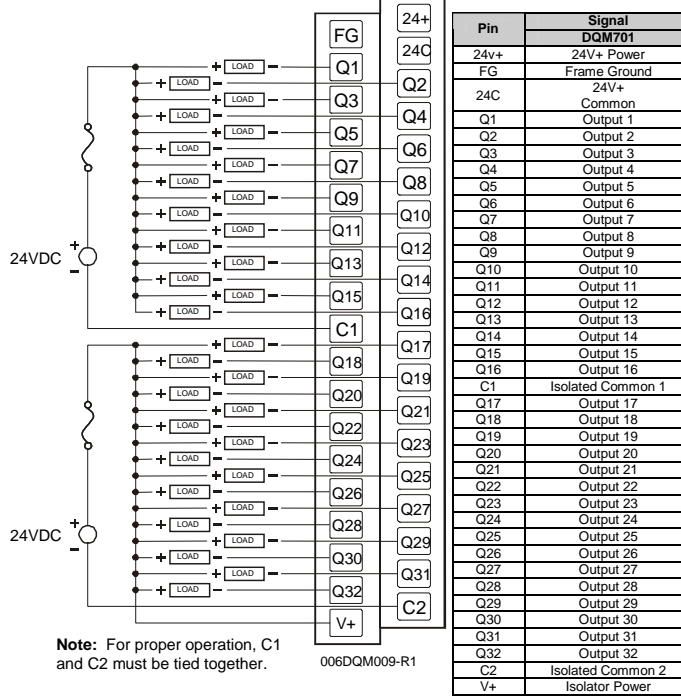

e. **DQM602: 16 RELAY OUTPUTS**

DQM602 Relay Outputs			
Number of output points	16	Maximum Load Current (resistive)	2.0A per channel 5.0A per common
Commons per Module	2	OFF to ON Response	10ms. Max.
Rated Load Voltage	24VDC, 220VAC	ON to OFF Response	12ms. Max.
Minimum load voltage / current	5VDC / 1mA	Output Type	N.O.
Internal power Consumption (mA)	550mA	Weight	9.91oz. (281 g)

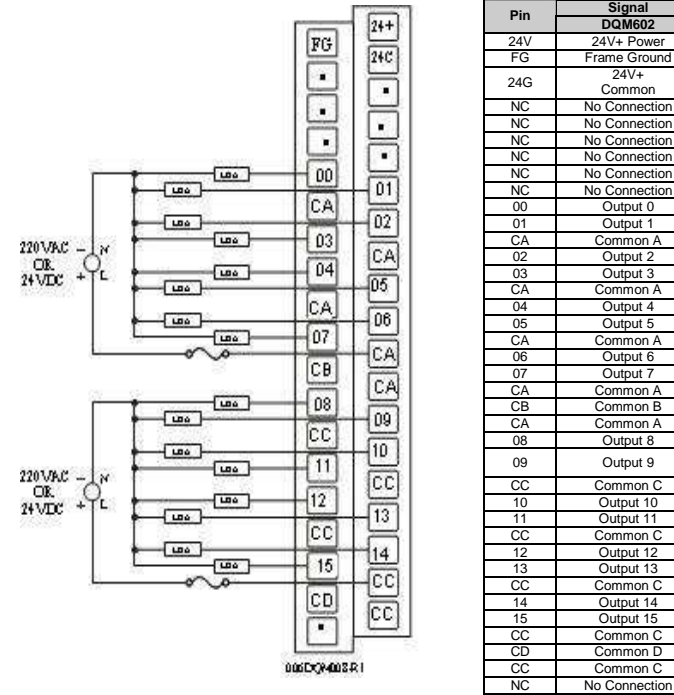

Warning: To protect the module and associated wiring from load faults, use external fuse (5 A) as shown.

Warning: Connecting high voltage to any I/O pin may cause high voltage to appear at other I/O pins.

Warning: Wiring the line side of the AC source to loads connected to outputs 0 through 15 and the neutral side of the AC source to the output common(s) would create a Negative Logic condition, which may be considered an unsafe practice.

f. **DIQ811: 16 DC IN, Positive/Negative / 16 DC OUT, Negative Logic**
DIQ816: 16 DC IN, Positive / 16 DC OUT, Positive Logic

DIQ811 / 816 IN			
Number of input points	16	OFF to ON Response	0 - 3ms. or less
Rated Input Current	7mA	ON to OFF Response	0 - 3ms. or less
ON Voltage Level	19VDC or less	Common Terminal	16 points / COM
OFF Voltage Level	6VDC or less	Operating Indicator	LED turns on during ON state of input
Input Characteristics	Bidirectional	External Connections	Terminal block connector (M3 x 6 screws)
Isolation Method	Photo Coupler		



DIQ811 / 816 OUT continued				
Number of output points	16	External Power Supply	Voltage	24VDC ± 10% (ripple voltage: 4Vp-p or less)
Commons per Module	1		Current	30mA (TYP, All points ON)
Operating Voltage	24VDC	OFF to ON Response	1ms. or less	
Rated Load Voltage	24VDC	ON to OFF Response	1ms. or less	
Max. Load Current per channel	DIQ 811	Output Type	DIQ811	Sinking
	DIQ 816		DIQ816	Sourcing
Max. Inrush Current per channel	DIQ 811	Max. Inrush Current per channel	DIQ811	0.4A, 10ms.
	DIQ 816		DIQ816	1A, 10ms
OFF Leakage Current	0.1mA or less		Common Method	16 points / COM
Max. Inrush Current per channel	DIQ 811	Operating Indicator	LED turns on during ON state of output	
	DIQ 816		External connections	Terminal block connector (M3 x 6 screws)
Internal power Consumption (mA)	DIQ811	Weight	DIQ811	8.9oz. (254 g)
	DIQ816		DIQ816	10.0oz. (284 g)

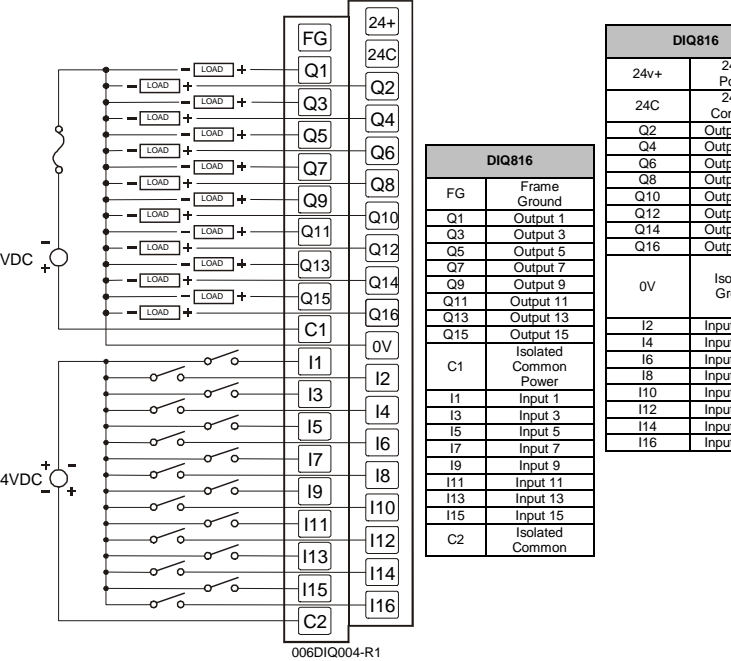
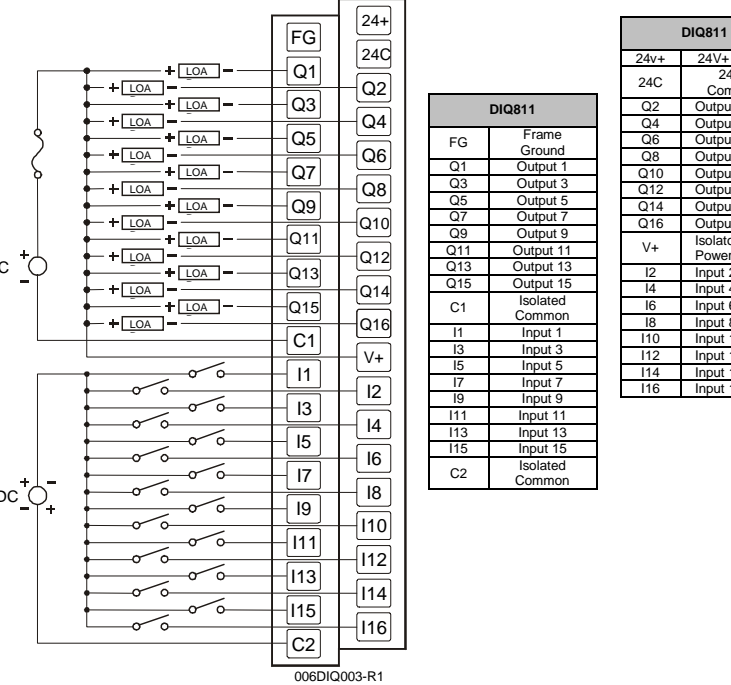

10 Internal Wiring

a. DIM610

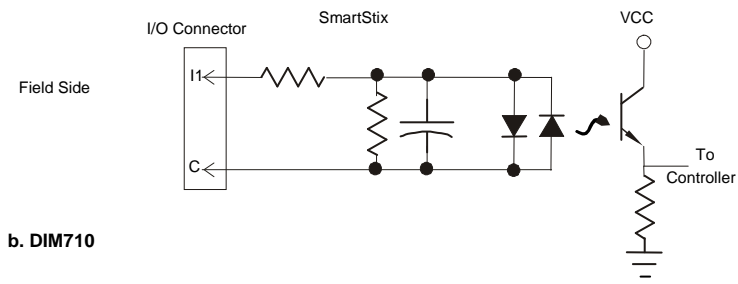

b. DIM710

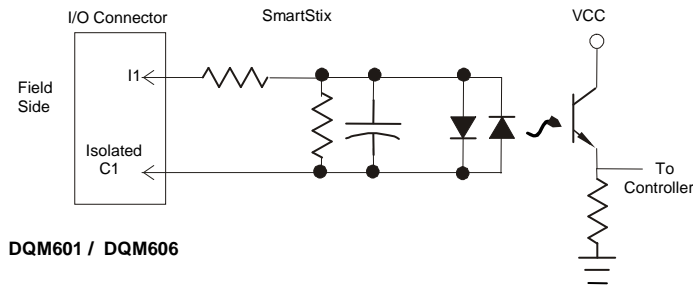

c. DQM601 / DQM606

DQM601

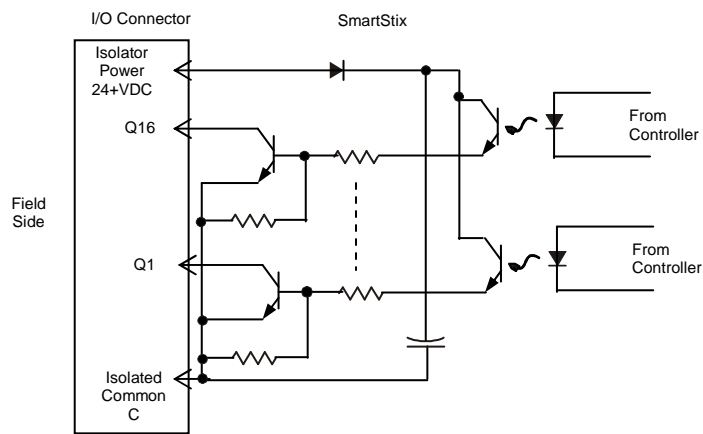

DQM606

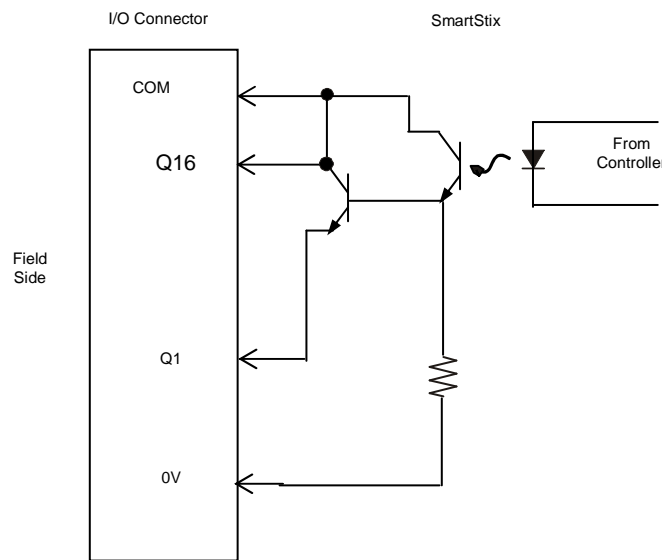

d. DQM701 / DQM706

DQM701

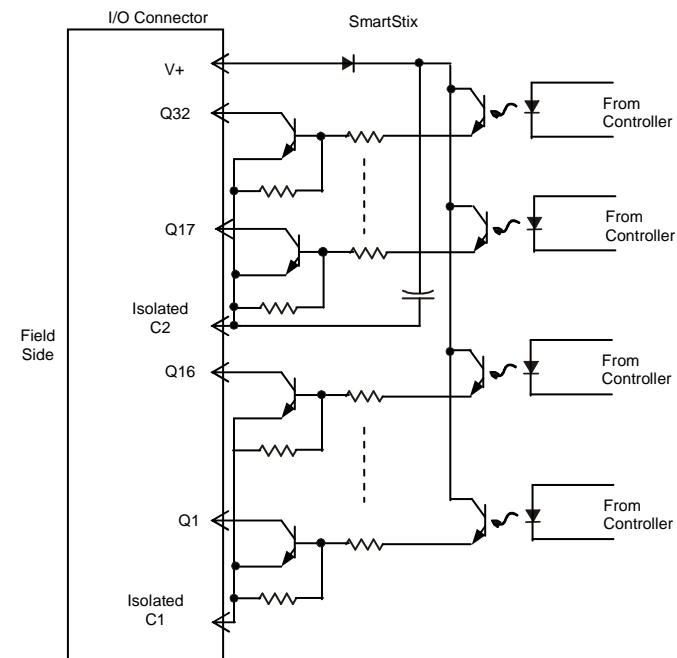

DQM706

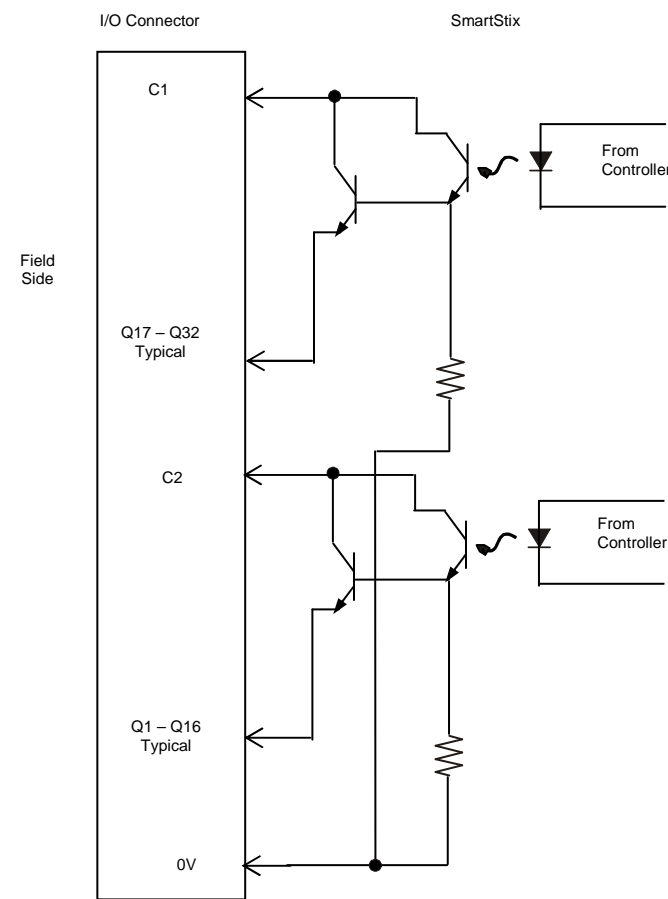

e. DQM602

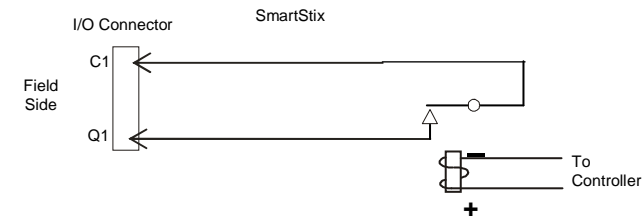

Specification for transient voltage suppressors (transorbs) used on output circuitry is 400VDC, bi-directional 400 watts.

Electro-mechanical relays comply with IEC1131-2.

f. DIQ811 / DIQ816

DIQ811

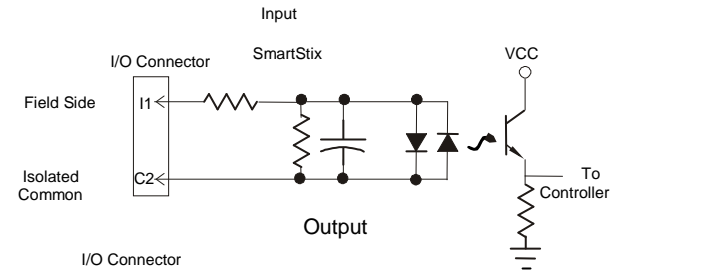

DIQ816

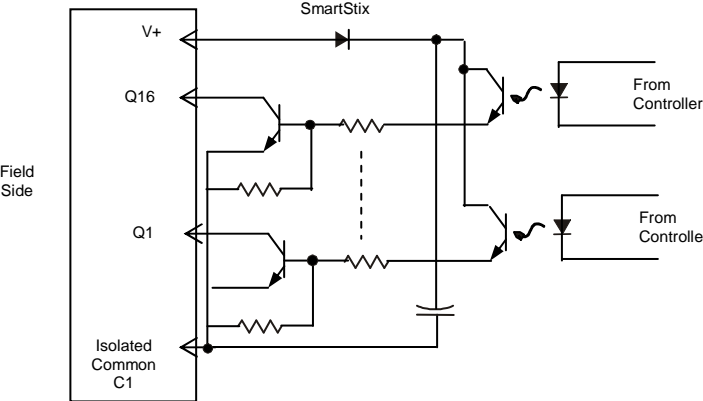

DIQ816

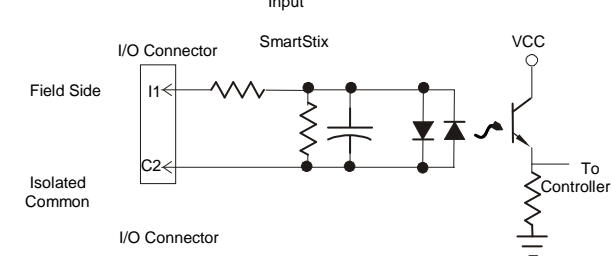

DIQ816

