



SmartStix™ HE559DIM610/HE559DIM710

Remote I/O for the OCS/RCS Family

16 DC Inputs (24VDC, positive/negative logic) / 32 DC Inputs (24VDC, positive/negative logic)

1 GENERAL SPECIFICATIONS

General Specifications				
Storage Temperature	-25° to 70° C	Operating and Storage Humidity	5 to 95% Non-condensing	
Operating Temperature	0° to 55° C	Pollution degree	2 or lower	
Atmosphere	Free from corrosive gases and excessive dust	Cooling method	Self-cooling	
Vibration				
Occasional Vibration				
Frequency	Acceleration	Amplitude	Sweep Count	
10 ≤ f < 57 Hz	-	0.075 mm	10 times in each direction for X,Y,Z	
57 ≤ f ≤ 150 Hz	9.8 m/s ² {1G}	-		
Continuous Vibration				
Frequency	Acceleration	Amplitude	Sweep Count	
10 ≤ f < 57 Hz	-	0.035 mm	10 times in each direction for X,Y,Z	
57 ≤ f ≤ 150 Hz	4.9 m/s ² {0.5G}	-		
Shocks				
Maximum shock acceleration	147 m/s ² {15G}			
Duration Time	11 ms.			
Pulse Wave	Half sine wave pulse (3 times in each of X, Y, Z directions)			
Noise Immunity				
Square wave impulse noise	AC: ± 1,500VDC DC: ± 900VDC			
Electrostatic Discharge	Voltage: 4kV (contact discharge)			
Radiated electromagnetic field	27 – 500MHz, 10V/m			
Fast Transient Burst Noise	Severity level	All power modules	Digital I/Os (Ue ≥ 24V)	Digital I/Os (Ue < 24 V) Analog I/Os Communication I/Os
	Voltage	2 kV	1 kV	0.25 kV

2 DIMENSIONS

a. DIM710

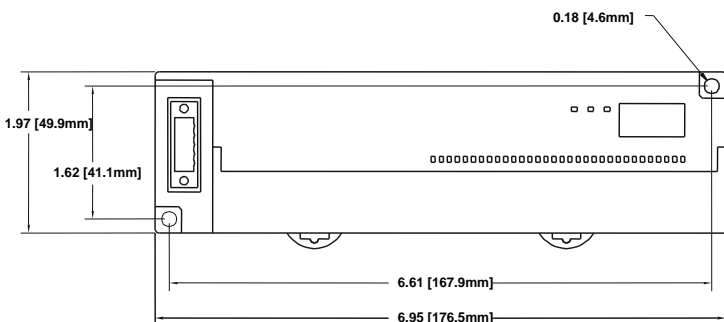

b. DIM610

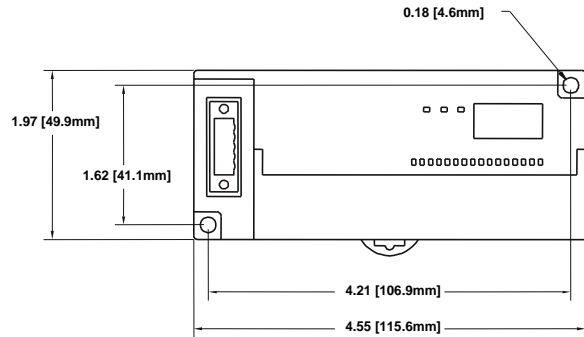

c. Terminal Strips

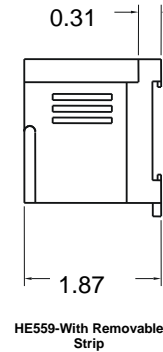

3 NETWORK CABLE

For detailed wiring information, refer to the Control Station Hardware Manual. A handy checklist is provided that covers panel box layout requirements and minimum clearances. See Section 10 for our web address.

Color	Pin	Description	Recommended Cable
RED	1	V+	Thick: (Max Distance = 500m) Belden 3082A
WHT	2	CAN_H	
NC	3	No Connection	Thin: (Max Distance = 100m) Belden 3084A
BLU	4	CAN_L	
BLK	5	V-	

4 ID SWITCHES (SETTING CSCAN NETWORK IDs)

CsCAN Network IDs are set using the hexadecimal number system from 01 to FD. The decimal equivalent is 1-253. Refer to Section 8, which shows the decimal equivalent of hexadecimal numbers. Set a unique Network ID by inserting a small Phillips screwdriver into the two identical switches. **Note:** The CsCAN Baud Rate for SmartStix I/O is fixed at 125KBaud

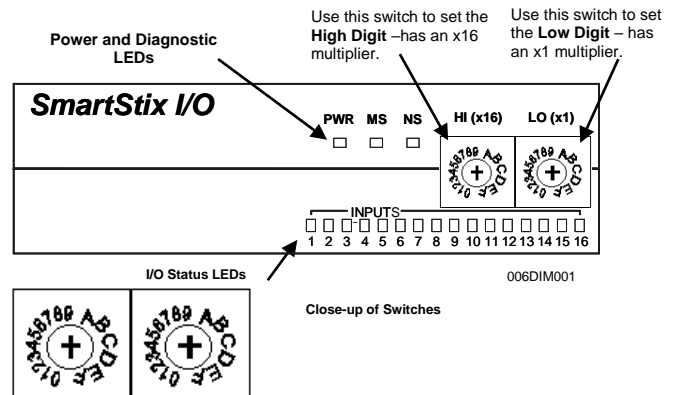

5 LEDs

a. Diagnostic LED Indicators

Diagnostic LED	State	Meaning
MS: (indicates fault status of Module)	Solid Red	RAM or ROM test failed
	Blinking Red	I/O test failed
	Blinking Green	Module is in power-up state
	Solid Green	Module is running normally
NS: (indicates fault status of Network)	Solid Red	Network Ack or Dup ID test failed
	Blinking Red	Network ID test failed
	Blinking Green	Module is in Life Expectancy default state
	Solid Green	Network is running normally

b. Status LED Indicators

The Power Status LED illuminates Red when power is applied to the module. There are I/O Status LED indicators for each of the Digital I/O points, which illuminate Red when an I/O point is ON.

6 WIRING

a. 16 DC IN, Positive Logic / Negative Logic

DIM610 Specifications			
Number of input points	16	OFF to ON Response	0 - 3ms. or less
Rated Input Current	7mA	ON to OFF Response	0 - 3ms. or less
ON Voltage Level	19VDC or higher	Common Terminal	16 points / COM
OFF Voltage Level	6VDC or less	Operating Indicator	LED turns on during ON state of input
Input Characteristics	Bidirectional	External Connections	Terminal block connector (M3 x 6 screws)
Isolation Method	Photo Coupler	Altitude for use	Up to 2,000m
Rated Voltage	11 - 25 VDC	Weight	5.6 oz. (159 g)
Internal power Consumption (mA)	200mA		

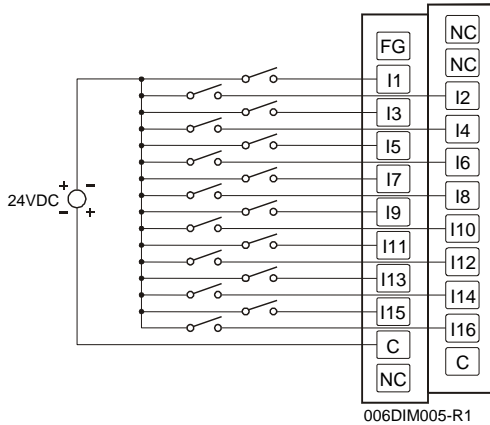

Pin	Signal DIM610
NC*	No Connection (*Do not Connect)
FG	Frame Ground
NC*	No Connection (*Do not Connect)
I1	Input 1
I2	Input 2
I3	Input 3
I4	Input 4
I5	Input 5
I6	Input 6
I7	Input 7
I8	Input 8
I9	Input 9
I10	Input 10
I11	Input 11
I12	Input 12
I13	Input 13
I14	Input 14
I15	Input 15
I16	Input 16
C	Common
C	Common
NC	No Connection

b. 32VDC IN, Positive Logic / Negative Logic

DIM710 INPUTS			
Number of input points	32	OFF to ON Response	0 - 3ms. or less
Rated Input Current	7mA	ON to OFF Response	0 - 3ms. or less
ON Voltage Level	19VDC or higher	Common Terminal	16 points / COM
OFF Voltage Level	6VDC or less	Operating Indicator	LED turns on during ON state of input
Isolation Method	Photo Coupler	External Connections	Terminal block connector (M3 x 6 screws)
Input Characteristics	Bidirectional	Weight	8.36oz. (237 g)
Rated Voltage	11 - 25 VDC		
Internal power Consumption (mA)	300		

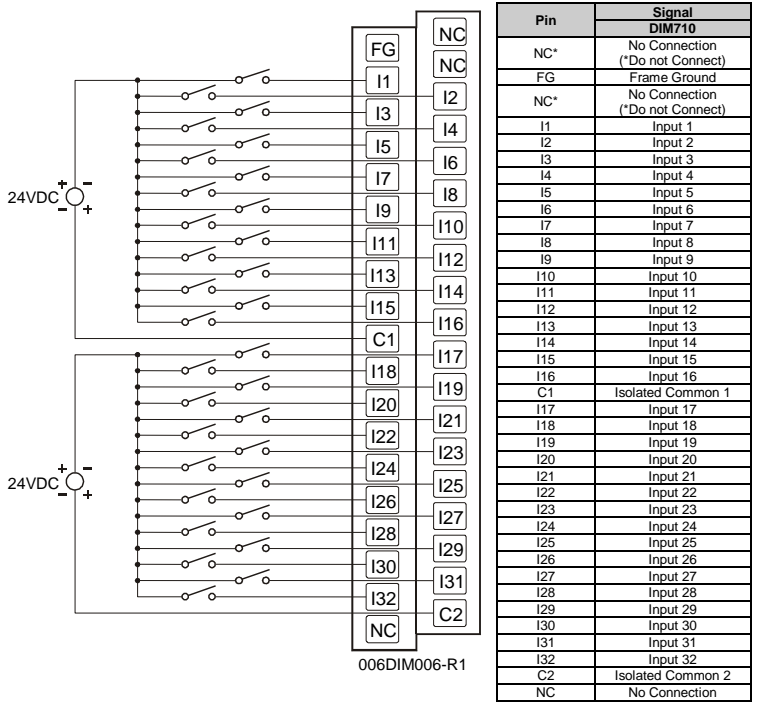

Pin	Signal DIM710
NC*	No Connection (*Do not Connect)
FG	Frame Ground
NC*	No Connection (*Do not Connect)
I1	Input 1
I2	Input 2
I3	Input 3
I4	Input 4
I5	Input 5
I6	Input 6
I7	Input 7
I8	Input 8
I9	Input 9
I10	Input 10
I11	Input 11
I12	Input 12
I13	Input 13
I14	Input 14
I15	Input 15
I16	Input 16
C1	Isolated Common 1
I17	Input 17
I18	Input 18
I19	Input 19
I20	Input 20
I21	Input 21
I22	Input 22
I23	Input 23
I24	Input 24
I25	Input 25
I26	Input 26
I27	Input 27
I28	Input 28
I29	Input 29
I30	Input 30
I31	Input 31
I32	Input 32
C2	Isolated Common 2
NC	No Connection

7 INTERNAL WIRING

a. DIM610

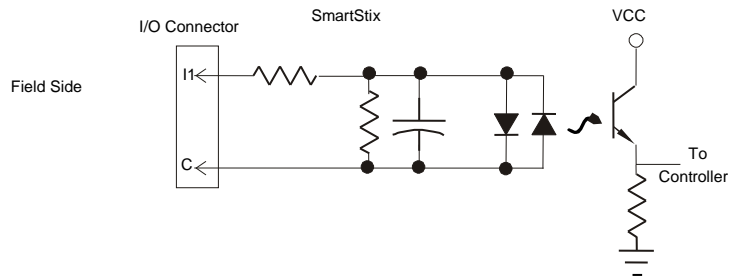

b. DIM710

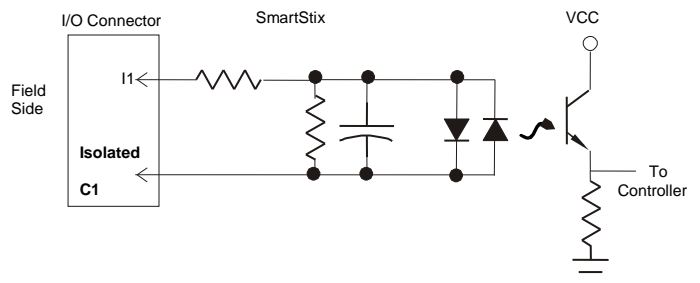

8 DECIMAL (DEC) TO HEXADECIMAL (HEX) CONVERSION TABLE

Dec	Hex		Dec	Hex		Dec	Hex	
	HI	LO		HI	LO		HI	LO
0	0	0	86	5	6	172	A	C
1	0	1	87	5	7	173	A	D
2	0	2	88	5	8	174	A	E
3	0	3	89	5	9	175	A	F
4	0	4	90	5	A	176	B	0
5	0	5	91	5	B	177	B	1
6	0	6	92	5	C	178	B	2
7	0	7	93	5	D	179	B	3
8	0	8	94	5	E	180	B	4
9	0	9	95	5	F	181	B	5
10	0	A	96	6	0	182	B	6
11	0	B	97	6	1	183	B	7
12	0	C	98	6	2	184	B	8
13	0	D	99	6	3	185	B	9
14	0	E	100	6	4	186	B	A
15	0	F	101	6	5	187	B	B
16	1	0	102	6	6	188	B	C
17	1	1	103	6	7	189	B	D
18	1	2	104	6	8	190	B	E
19	1	3	105	6	9	191	B	F
20	1	4	106	6	A	192	C	0
21	1	5	107	6	B	193	C	1
22	1	6	108	6	C	194	C	2
23	1	7	109	6	D	195	C	3
24	1	8	110	6	E	196	C	4
25	1	9	111	6	F	197	C	5
26	1	A	112	7	0	198	C	6
27	1	B	113	7	1	199	C	7
28	1	C	114	7	2	200	C	8
29	1	D	115	7	3	201	C	9
30	1	E	116	7	4	202	C	A
31	1	F	117	7	5	203	C	B
32	2	0	118	7	6	204	C	C
33	2	1	119	7	7	205	C	D
34	2	2	120	7	8	206	C	E
35	2	3	121	7	9	207	C	F
36	2	4	122	7	A	208	D	0
37	2	5	123	7	B	209	D	1
38	2	6	124	7	C	210	D	2
39	2	7	125	7	D	211	D	3
40	2	8	126	7	E	212	D	4
41	2	9	127	7	F	213	D	5
42	2	A	128	8	0	214	D	6
43	2	B	129	8	1	215	D	7
44	2	C	130	8	2	216	D	8
45	2	D	131	8	3	217	D	9
46	2	E	132	8	4	218	D	A
47	2	F	133	8	5	219	D	B
48	3	0	134	8	6	220	D	C
49	3	1	135	8	7	221	D	D
50	3	2	136	8	8	222	D	E
51	3	3	137	8	9	223	D	F
52	3	4	138	8	A	224	E	0
53	3	5	139	8	B	225	E	1
54	3	6	140	8	C	226	E	2
55	3	7	141	8	D	227	E	3
56	3	8	142	8	E	228	E	4
57	3	9	143	8	F	229	E	5
58	3	A	144	9	0	230	E	6
59	3	B	145	9	1	231	E	7
60	3	C	146	9	2	232	E	8
61	3	D	147	9	3	233	E	9
62	3	E	148	9	4	234	E	A
63	3	F	149	9	5	235	E	B
64	4	0	150	9	6	236	E	C
65	4	1	151	9	7	237	E	D
66	4	2	152	9	8	238	E	E
67	4	3	153	9	9	239	E	F
68	4	4	154	9	A	240	F	0
69	4	5	155	9	B	241	F	1
70	4	6	156	9	C	242	F	2
71	4	7	157	9	D	243	F	3
72	4	8	158	9	E	244	F	4
73	4	9	159	9	F	245	F	5
74	4	A	160	A	0	246	F	6
75	4	B	161	A	1	247	F	7
76	4	C	162	A	2	248	F	8
77	4	D	163	A	3	249	F	9
78	4	E	164	A	4	250	F	A
79	4	F	165	A	5	251	F	B
80	5	0	166	A	6	252	F	C
81	5	1	167	A	7	253	F	D
82	5	2	168	A	8	254	F	E
83	5	3	169	A	9	255	F	F
84	5	4	170	A	A			
85	5	5	171	A	B			

9 INSTALLATION / SAFETY

- a. All applicable codes and standards need to be followed in the installation of this product.
- b. For I/O wiring (discrete), use the following wire type or equivalent: Belden 8441 or equivalent.
- c. For detailed installation information, refer to Chapter Two in the Control Station Hardware Manual (MAN0227). A **handy checklist** is provided that covers panel box layout requirements and minimum clearances.



Warning: Consult user documentation.



Warning: Electrical Shock Hazard.

Warning: To protect the module and associated wiring from load faults, use external fuse (5 A).

Warning: Connecting high voltage to any I/O pin may cause high voltage to appear at other I/O pins.

Warning: Wiring the line side of the AC source to loads connected to outputs 0 through 15 and the neutral side of the AC source to the output common(s) would create a Negative Logic condition, which may be considered an unsafe practice.

10 TECHNICAL ASSISTANCE

For assistance and manual updates, contact Technical Support at the following locations:

<p>North America: Tel: 317 916-4274 Fax: 317 639-4279 Web: www.hornerautomation.com Email: techspt@heapg.com</p>	<p>Europe: Tel: +353-21-4321266 Fax: +353-21-4321826 Web: http://www.horner-apg.com Email: technical.support@horner-apg.com</p>
--	--

Cscape, SmartStix and CsCAN are trademarks of Horner APG. This information is subject to change without notice.