



SmartRail I/O – Profibus Base HE599PBX100

1 INTRODUCTION

SmartRail I/O is a real-time, modular I/O system – expanding the application of the OCS family of all-in-one controllers. The SmartRail I/O Profibus Base (PBX100) utilizes Profibus Networking for the I/O connection with the OCS or third-party controller. The high-speed nature of Profibus allows a significant amount of I/O to be added while maintaining fast I/O updates.

Any OCS Controller supporting SmartStack I/O, with a PBM650 Profibus Master Module can utilize SmartRail I/O through the PBM100 Base units. Each PBX100 base can support up to 8 SmartRail I/O modules – addressed with up to 256 digital I/O and 32 analog I/O per (16 in + 16 out) base. The number of bases used per system is limited only by the Profibus specification.

Note: The SmartRail I/O Profibus base is NOT directly supported by the XLe, XLt & XL6 series of all-in-one controllers. It is supported by the NX, QX, RX and RCX controllers with a PBM650 SmartStack module added.

2 SPECIFICATIONS

General Specifications			
Required Power (Steady State)	550mA @ 24 VDC		
Primary Power Range	19.2 – 28.8 VDC		
Output Power	1500mA @ 5 VDC		
Relative Humidity	5 to 95% Non-condensing		
Operating Temperature	0°C to +55°C		
Storage Temperature	-25°C to +70°C		
Weight	100g (3.5 oz.)		
Vibration & Shock	Per IEC1131-2		
Noise Immunity	Per IEC1131-2, IEC61000-4-2, IEC61000-4-3, IEC61000-4-4		
CE	Yes		
UL & C-UL	Ordinary location		
Communications Specifications			
Data Transmission	9.6k to 12.0Mbps		
Interface	RS-485		
Connectors	9pin D-sub (Field Termination Kit included)		
I/O Protocol	Profibus DP		
Media Access	Polling Method		
ID configuration	0-99, using rotary switches		
OCS Interface	PBM650 SmartStack Module		
OCS Configuration	Cscape (using HSYcon tool)		
I/O Specifications			
Compatible I/O	SmartRail I/O		
Modules Supported (per base)	8		
Digital I/O, max (per base)	256 total (Inputs + Outputs)		
Analog I/O, max (per base)	16 analog inputs + 16 analog outputs		
I/O Limitations (per system)	2048 Digital In, 2048 Digital Out, 512 Analog In, 512 Analog Out		
Power Supplied for I/O modules	1500mA @ 5V DC maximum		
I/O Module 5V Power Usage (1500mA total available)			
8 DC In DIM510 30mA	16 DC In DIM610 40mA	32 DC In DIM710 50mA	8 DC Out DQM506 40mA
16 DC Out DQM606 60mA	32 DC Out DQM706 120mA	8 Relay Out DQM502 230mA	16 Relay Out DQM602 420mA
8DC + 8 Relay DIQ512 250mA	4 Analog In ADC170 50mA	4 RTD In RTD100 100mA	4 T-couple In THM100 100mA
4 Anlg. Out (mA) DAC106 120mA	4 Analog Out (V) DAC101 70mA	2 Analog In + 2 Analog Out MIX116 100mA	

3 INSTALLATION

3.1 Physical Installation

The PBX100 is compact (45mm W x 90mm H x 60mm D), and mounts on DIN-rail. Each I/O module installed adds width in increments of 20mm (for DC & analog I/O) or 27mm (for relay I/O).

NOTE: The distance between wiring duct and surrounding modules should be at least 50mm apart.

Modules can be added either before or after the PBX100 base has been installed on the DIN-rail – but never with the PBX100 under power.

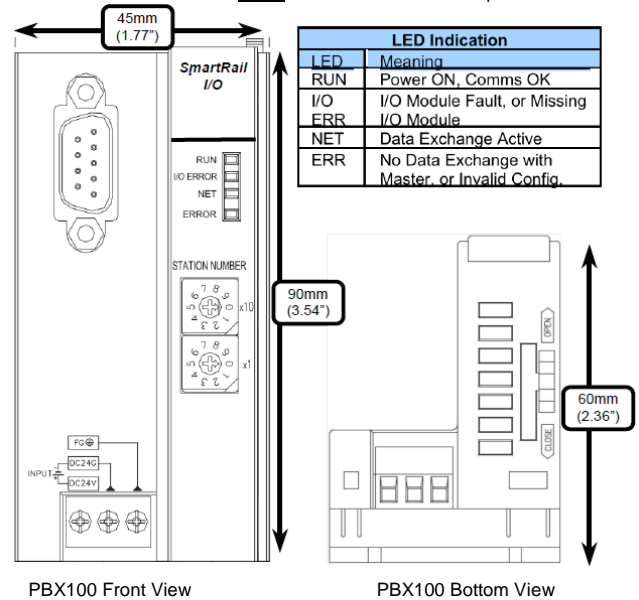

I/O modules are physically added with the following procedure:

1. Remove the cover for the expansion connector from the PBX100 base, and for all but the rightmost I/O module in the system.
2. Make sure that the locks on the top and bottom of the PBX100 base are slid all the way to the front in the "Open" position.
3. Align the first I/O module to the right of the PBX100 base using the alignment features in the plastic case.
4. After affixing the module securely, slide the locks on the top and bottom of the base all the way to back in the "Close" position.
5. Repeat steps 2-4 above until all modules are affixed.
6. Hang the PBX100 base and all the affixed I/O modules to the top of the DIN-rail and secure them by sliding the DIN-rail latches to the "up" position.

3.2 Wiring

Each SmartRail PBX100 Base requires 24VDC power, and an appropriate Earth Ground connection for normal operation. The 9pin female D-sub follows the Profibus DP convention, and a convenient field termination kit is included with the PBX100. The Termination switch (located on the field termination kit) should be switched to the "ON" position at each segment end-point.

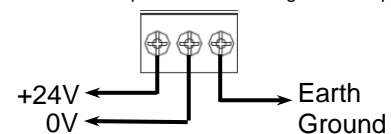

24VDC Power Supply & Earth Ground Terminals

3.3 Software Configuration

For connection of a SmartRail PBX100 Base to an OCS control system, the SmartStack PBM650 Profibus Master module is required. This module is configured from Cscape, using the Hsycon tool. For details on the configuration of the PBM650 module, see Horner document MAN0575-04-EN, available from the Manuals section of our web site.

In the process of the Hsycon configuration, the GSD file for the HE599PBX100 will be referenced. This file (PBX100.gsd) is available from the Tech Support Downloads section of our web site.

3.4 Analog Module Parameter Data

Digital I/O modules connected to the PBX100 do not have any configuration data. The digital module configuration data is fixed at 3mS input filtering for input modules, and Hold Last State = None for digital output modules.

Analog modules have parameter data set from Hsycon during the slave configuration process. There is one byte of parameter data set per PBX100 slot. The meaning of the parameter data for each analog module is shown in the chart below:

Analog Module Parameter Settings			
Module	Parameter Value (Dec)	Analog Setting	Digital I/O Value
HE599ADC170	0	0-10V	0-4000
	1	0-20mA	
	2	4-20mA	
	3	0-10V	
	4	0-20mA	-2000 - +2000
	5	4-20mA	
	6	0-10V	
	7	0-20mA	
HE599DAC101	0	0-10V	0-4000
	1		0-1000
	2		-2000 - +2000
	3		
HE599DAC106	0	4-20mA	0-4000
	1	0-20mA	0-1000
	2	4-20mA	
	3	0-20mA	
HE599RTD100	0	PT-100	°C (x10)
	1	PT-100 (J)	°F (x10)
	2	PT-100	
	3	PT-100 (J)	
HE599THM100	0	K	°C (x10)
	1	J	
	2	T	
	3	R	
	4	K	°F (x10)
	5	J	
	6	T	
	7	R	
HE599MIX116	0	1-5V	0-4000
	4	0-5V	
	8	0-10V	
	12	4-20mA	
	16	0-20mA	

NOTE: Revision "B" or later of the HE599PBX100 required for support of the THM100 & MIX116 modules.

4 SAFETY

When found on the product, the following symbols specify:



Warning: Consult user documentation.



Warning: Electrical Shock Hazard.

WARNING: To avoid the risk of electric shock or burns, always connect the safety (or earth) ground before making any other connections.

WARNING: To reduce the risk of fire, electrical shock, or physical injury it is strongly recommended to fuse the voltage measurement inputs. Be sure to locate fuses as close to the source as possible.

WARNING: Replace fuse with the same type and rating to provide protection against risk of fire and shock hazards.

WARNING: In the event of repeated failure, do not replace the fuse again as a repeated failure indicates a defective condition that will not clear by replacing the fuse.

WARNING: Only qualified electrical personnel familiar with the construction and operation of this equipment and the hazards involved should install, adjust, operate, or service this equipment. Read and understand this manual and other applicable manuals in their entirety before proceeding. Failure to observe this precaution could result in severe bodily injury or loss of life.

- All applicable codes and standards need to be followed in the installation of this product.
- For network wiring, use Profibus cable type (Belden 3077F, 3079A or equivalent)
- For I/O wiring (discrete), use the following wire type or equivalent: Belden 9918, 18 AWG or larger.

Adhere to the following safety precautions whenever any type of connection is made to the module.

- Connect the green safety (earth) ground first before making any other connections.
- When connecting to electric circuits or pulse-initiating equipment, open their related breakers. Do not make connections to live power lines.
- Make connections to the module first; then connect to the circuit to be monitored.
- Route power wires in a safe manner in accordance with good practice and local codes.
- Wear proper personal protective equipment including safety glasses and insulated gloves when making connections to power circuits.
- Ensure hands, shoes, and floor are dry before making any connection to a power line.
- Make sure the unit is turned OFF before making connection to terminals. Make sure all circuits are de-energized before making connections.
- Before each use, inspect all cables for breaks or cracks in the insulation. Replace immediately if defective.

5 TECHNICAL SUPPORT

For assistance and manual updates, contact Technical Support at the following locations:

<p>North America: Tel: (317) 916-4274 Fax: (317) 639-4279 Web: http://www.hornerautomation.com Email: techspt@heapg.com</p>	<p>Europe: Tel: +353-21-4321266 Fax: +353-21-4321826 Web: http://www.horner-apg.com Email: technical.support@horner-apg.com</p>
---	--

No part of this publication may be reproduced without the prior agreement and written permission of Horner APG, Inc. Information in this document is subject to change without notice.