



Remote Control Station HE800RCS116/ HE800RCS210 / RCS250

Products Specifications and Installation Data

For more information on the **RCS116**, refer to the *OCS LX Series Hardware Manual* (MAN0755).

For more information on the **RCS210 / RCS250**, refer to the *Control Station Hardware Manual* (MAN0227).

1 SPECIFICATIONS

Table 1 – Specifications for RCS116 / 210RCS210 / RCS250	
Humidity	5% to 95% non-condensing
Primary Power Range*	10-30VDC
Ladder Execution	
Typical Execution Speed	0.7 ms. per 1K of boolean logic.
Ladder Capacity	RCS116: 16Kbytes RCS210: 64Kbytes RCS250: 128KBytes
CAN Power Range	12 – 25 VDC
CAN Power Current	75mA maximum
Primary Serial	Standard 9 pin RS-232 for programming, monitoring, and network administration. Modbus/RTU Master, Slave, ASCII Send and Receive, and CsCAN Serial also supported.
CAN Network	CsCAN Network / DeviceNet Slave
Input / Output	Local (All Modules): Maximum of four (4) SmartStack Modules per OCS Remote (OCS110 / 210/ 250 / or RCS250 Modules): In addition to 4 local I/O modules, up to 20 remote SmartStack I/O Modules can be connected to an OCS or RCS using five Fiber Optic Bases, which each contain four I/O slots.
UL	Please refer to Compliance Table located at http://www.heapg.com/Support/compliance.htm
CE	
Operating Temperature	0°C to +60°C
Typical Power Draw *	150mA @ 24VDC
Inrush Current *	1A @ 24VDC for 8mS
Height	7.00" (177.8 mm)
Width	1.75" (44.45 mm)
Mounting Depth	4.00" (101.60 mm)
Keypad	Although the RCS does <u>not</u> have a local operator interface, it supports a remote operator interface through a PC connected to the RCS unit's built-in network. 32-Key (Remote Only)
Display	Although the RCS does <u>not</u> have local display, it supports a remote operator interface through a PC connected to the RCS unit's built-in network.
* These specifications are for RCS products without any SmartStack I/O Modules attached. The specifications for the SmartStack Modules can be found in the applicable SmartStack Data Sheets.	

2 INSTALLATION

2.1 Panel Cut-Out

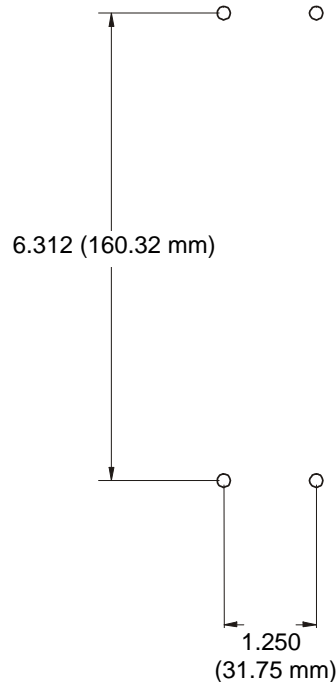

Figure 1 – Panel Cut-Out for the RCS

2.2 RCS Optional Mounting Bracket (HE800ACC210)

The optional mounting bracket is used with SmartStack Modules that have connectors located on two sides. (Note that many SmartStack Modules only have connectors on one side.)

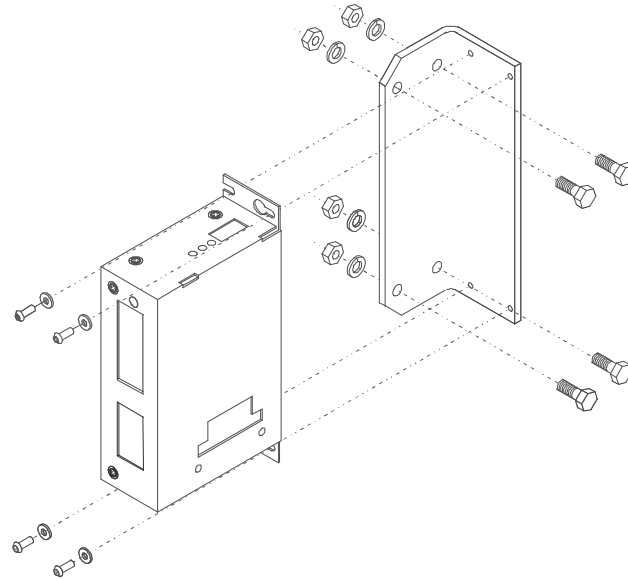

Figure 2 – Optional Mounting Bracket for Use with the RCS.

2.3 Ports, Connectors and Wiring

2.3.1 Primary Power Port

Table 2 – Primary Power Port Pins		
Pin	Signal	Description
1	V+	Input power supply voltage
2	V-	Input power supply ground

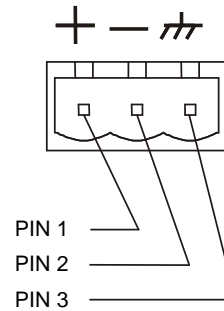
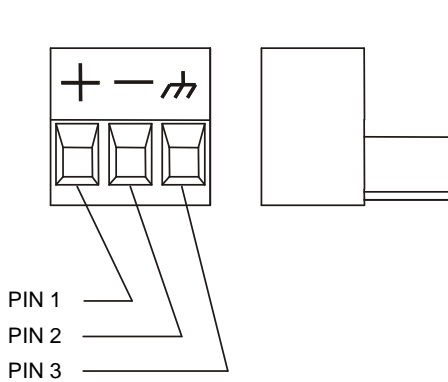

Figure 3 - Power Connector (Primary Power Port)

Figure 4 – As Viewed Looking at the RCS

Note: Power Supply Voltage Range is from 10-30 VDC.

Warning: To provide maximum noise immunity and to ensure minimum EMI radiation, the V- signal (DC power return) need to be connected to earth ground at the power supply. The user must ensure that the power supply selected is compatible with this method of grounding.

2.3.2 CAN / DeviceNet Network Port and Wiring

a. Network Connector

Table 3 – CAN Port Pins		
Pin	Signal	Description
1	V-	Power -
2	CN_L	Signal -
3	SHLD	Shield
4	CN_H	Signal +
5	V+	Power +

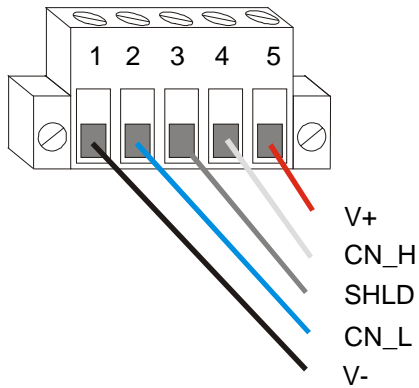

Figure 5 – Network Connector

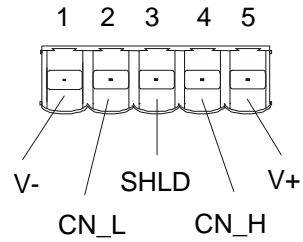

Figure 6 – As viewed at the RCS

Warning: To provide maximum noise immunity and to ensure minimum EMI radiation, the V- signal (DC power return) need to be connected to earth ground at the power supply. The user must ensure that the power supply selected is compatible with this method of grounding.

b. Grounding

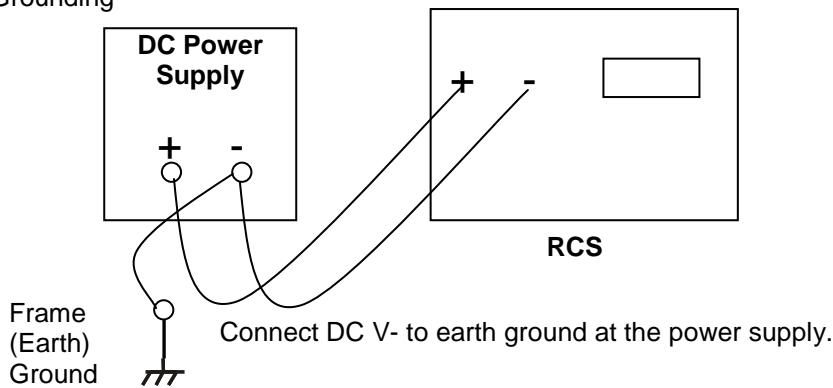

Figure 7 – Grounding Method

2.3.3 RS-232 Programming Port and Wiring

Table 4– RS-232 Port Pins			
Pin	Signal	Description	Direction
1	DCD	Always high	Out
2	RXD	Received Data	Out
3	TXD	Transmitted Data	In
4	DTR	Data Terminal Ready	In
5	GND	Ground	-
6	DSR	Data Set Ready	Out
7	RTS	Request to Send	In
8	CTS	Clear to Send	Out
9	RI	Ring Indicate	Out

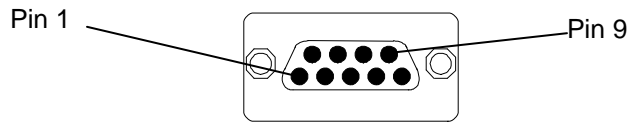

Figure 8 – RS-232 Port

The RCS units feature an RS-232 port (Programming/Debug) for connection to a personal computer. This port is used for the purposes of RCS programming, configuring, monitoring, and debugging. This port can also be used for general ladder logic controlled serial communications to printers, modems, terminals, etc. When ladder has control of this port, it is not available for programming or debugging. The wiring diagram for the RS-232 port is shown in Figure 8. If a permanent connection is to be made between the RCS and the personal computer, the use of a shielded, multiple conductor wire with a maximum length of 15.24 meters (50 feet) enables proper performance.

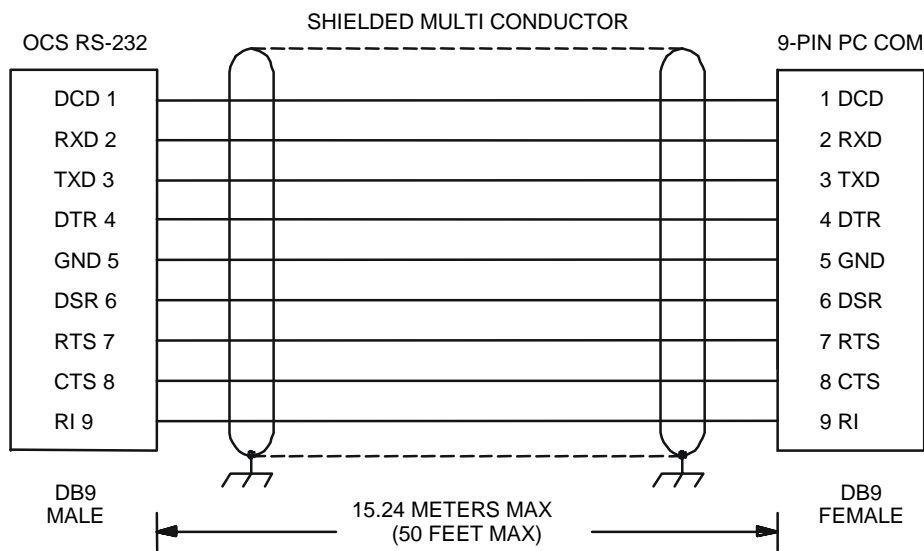

Figure 9- RCS to PC Wiring Diagram

3 LEDs

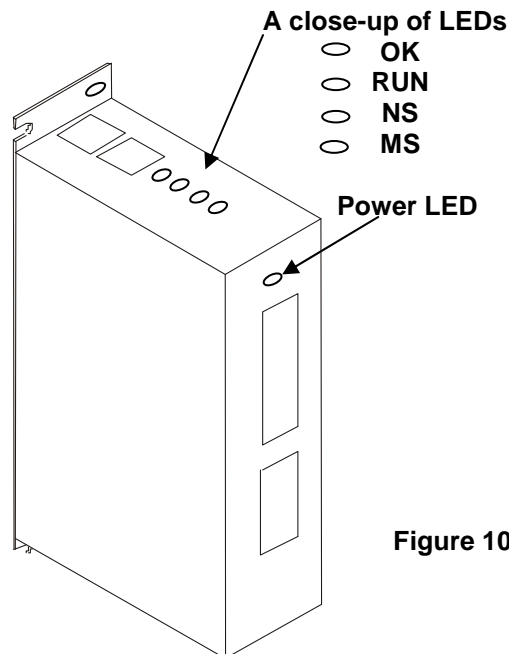

Figure 10 – RCS LEDs

Table 5 – LED Description	
LED	RCS
RUN	<ul style="list-style-type: none"> • OFF indicates OCS is in IDLE/STOP mode. • Flashing at 1 Hz indicates DO / IO mode or RUN with no ladder program. • ON indicates ladder code running.
OK	<ul style="list-style-type: none"> • OFF indicates one or more self-tests failed. • Flashing at 1 Hz indicates I/O forcing is active. • ON indicates all self-tests passed.
Module Status (MS) MS monitors RS-232 activity	<ul style="list-style-type: none"> • OFF indicates no RS-232 communication. • Red flickering indicates receive activity on the RS-232 port. • Green flickering indicates transmit activity on the RS-232 port. • Orange flickering indicates both transmit and receive activity on the RS-232 port. • Red solid ON indicates a <i>non-critical</i> self-test error was detected • Red flashing at 1Hz indicates a critical self-test error was detected.
Network Status (NS) NS monitors CAN port activity	<ul style="list-style-type: none"> • OFF indicates no CAN communication. • Red flickering indicates receive activity on the CAN port. • Green flickering indicates transmit activity on the CAN port. • Orange flickering indicates both transmit and receive activity on the CAN port. • Red solid ON indicates a CAN network error was detected.

4 SAFETY

All applicable codes and standards need to be followed in the installation of this product.

5 TECHNICAL ASSISTANCE

For updates and assistance, contact Technical Support at the following locations.

North America:

(317) 916-4274

www.heapg.com

Europe:

(+) 353-21-4321-266

www.horner-apg.com