

# Application Note for Using the Operator Station HE500TIU050 / 10X / 11X / 20X / 3XX with an Allen Bradley PLC supporting the DF1 Protocol

## 1.0. DF1 Support

The Operator Station DF1 protocol supports all models of Allen-Bradley PLC's. It gives access to Allen-Bradley Data Highway, Allen-Bradley Data Highway Plus and Allen-Bradley DH485 Networks via appropriate Allen Bradley network modules.

## 2.0. Protocol File Name

HE500TIU050 = DF1\_R?.0xx

HE500TIU1xx = DF1\_R?.1xx

HE500TIU2xx = DF1\_R?.2xx

HE500TIU3xx = DF1\_R?.3xx

(The "?" = the TIU firmware revision)

## 3.0. Configuring the Operator Station

To verify the Automated Equipment type the Operator Station is setup for, watch the screen of the Operator Station on power up. The first screen message details the setup of the Operator Station. To configure the Operator Station for particular Automated Equipment, select the Automated Equipment in the Communication Settings from the Configure menu in **CBREEZE** software. Select the appropriate Manufacturer and the appropriate Remote Equipment Model. Then from the File menu select Update Protocol, the appropriate file name will appear in the file name field. The programmer may need to point to the correct folder name/location. If further information is required see the manual or **CBREEZE** help on update/change protocol.

## 3.1. Register Ranges

Version 1.04 Supports master only operation to the slave PLC.

The current implementation supports only 3 Level addressing and not full 4 Level. This means that the Datafiles containing timers and counters only return the Control Word and not the preset and current values. To access the preset and current values map them to the integer Datafile in the PLC, which is then accessible to the Operator Station.

## 3.2. Link Configuration

The Operator Station must always be a master device on the link, and does not accept requests made on it. Version 1.03 and upwards of the protocol assumes the following characteristics of the DF1 node to which it is connected: -

- CRC error checking (not selectable) for added data security
- Full Duplex Operation (not selectable)

Other parameters may be required at the Allen Bradley Controller, which are less critical but have been configured on the Operator Station these are: -

Duplicate Packet Detection	Disabled
ACK	50ms
No Handshake	No
NAK	3
ENQ	3
Embedded Response	Autodetect

## 3.0. Serial Link Format

Care should be taken to match both ends of the link for baud rate and parity. The default setting for the Operator Station being 9600 baud with eight data bits, one stop bit and no parity. In addition ensure that the DF1 node connected to has handshaking lines disabled. Refer to your Allen Bradley documentation for details on configuring the DF1 port on the device to which the Operator Station is to be connected.

The protocol supports the read unprotected registers and write unprotected registers commands of the DF1 basic command set (PLC2 Command Set). These commands give access to data tables within the various PLCs in the range. In addition SLC500 Registers (applicable to the SLC500 and MicroLogix) and SLC500 Float (Floating point table) are supported.

## 4.0. Connection to an Allen-Bradley Series 5 PLC

When DF1 is used in implementing a connection to a PLC5, only one datafile may be accessed in the PLC. Where multiple PLCs are being accessed on a network the data file identifier must be the same for all PLCs accessed.

After selecting the target data file, it is specified in the **CBREEZE** Software project by modifying the Target Data File value, under the communication settings. The Target Data File field will only appear when the remote equipment model is set to PLC5.

When accessing PLC5s the data block size is in words and the start address is in bytes, hence to access the seventh word in a data block it is necessary to select a start address of fourteen when operating the terminal with a PLC5.

The target data file should be created as being of integer type and should contain sufficient elements to support all the reads and writes which will be directed at the

specified PLC. If the data file does not exist in the target PLC, or is of insufficient size to support an individual transaction, a 'BAD' transaction will occur.

Two possibilities exist for connection to a PLC5. Some PLC5 models are fitted with a DF1 port as standard, others of the PLC5 range require a networking module for either data highway or data highway plus.

## 4.1. Direct connection to the PLC5

### Direct connection to the PLC5

The following PLC5 models are fitted as standard with a port capable of supporting DF1 commands: -

- PLC5/11
- PLC5/20
- PLC5/30
- PLC5/40
- PLC5/60

## 4.2. Connection to PLC5's via Data Highway/Data Highway Plus

The following PLC5 models do not have a DF1 port fitted as standard, they do however have a Data Highway Plus port fitted as standard. The Operator Station can be connected to these PLCs via a 1770-KF2 module: -

- PLC5/10
- PLC5/12
- PLC5/15
- PLC5/25

## 4.3. Connecting to the MicroLogix Range

The Micro range unprotected reads and unprotected writes occur within data file 7. This data file should be created as being of integer type and should contain sufficient elements to support all the reads and writes directed at the specific PLC. The available range is N7:0 to N7:255

If data file 7 does not exist in the target PLC or is of insufficient size to support an individual transaction a 'BAD' transaction will occur.

Alternatively a specific data file can be accessed using "Specific Registers" the datafile and register being specified as shown below.

Data Type	Location Value	Register Addressed
Unprotected (Data File 7)	1	Register 1 of data file 7
Specific Register	5.025	Register 25 of data file 5

## 7.0. Connection details to AB 1770-KF2 Module RS422 Data Highway / Data Highway+

13-Pin Screw Terminal Block

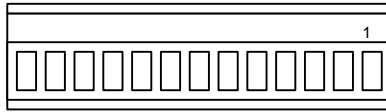

TIU100, TIU110

8-Pin Screw Terminal

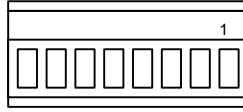

 TIU050, 101, 102, 103,  
111, 112, 113, 201,  
202, 203

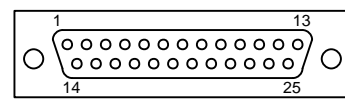
25-Pin D-Type Male

 TIU300, 301, 302, 303, 304,  
310, 311, 312, 313, 314,  
320, 321, 322, 323, 324

TIU Type	13-Pin	8-Pin	25-Pin
+5V	1		
TX 485/422+	2	1	12
TX 485/422-	3	2	13
RX 485/422+	4	3	24
RX 485/422-	5	4	25
TX RS232	6	5	2
Signal GND	7	6	7
RX RS232	8	7	3
Frame Gnd	13	8	1
RTS RS232	-	-	4
CTS RS232	-	-	5
RTS 485/422+	-	-	14
RTS 485/422-	-	-	17
CTS 485/422-	-	-	18
CTS 485/422+	-	-	19

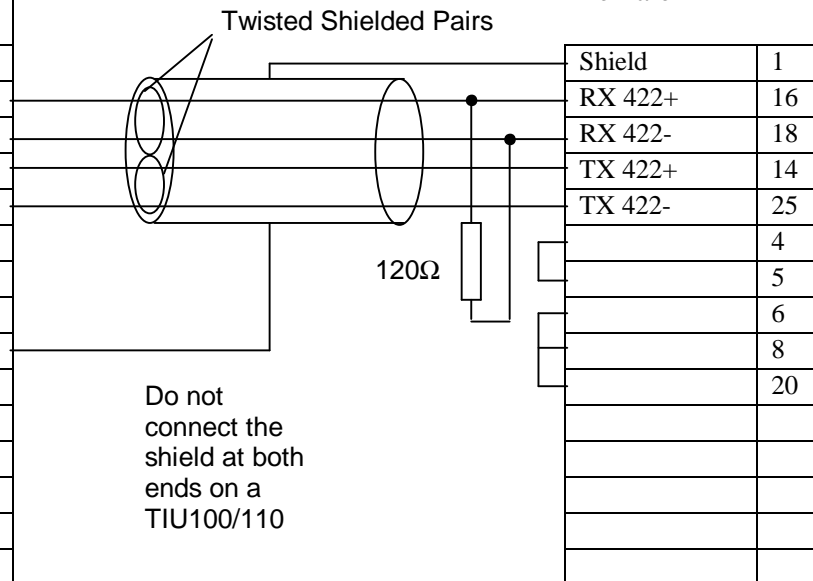
### RS422 Connection



Do not connect to unlisted pins.

### TIU1XX and 2XX PLC Port switch settings.

If the TIU is the last unit on a multi-drop network or is connected point to point then termination is required and the TIU PLC Port switch settings should be set as in figure 1. Below otherwise they should be set as in figure 2.

Switch	Description	State
1	Pull-up	On
2	120 Ω termination	On
3	Pull-down	On
4	Not used.	Off

Figure 1.

Switch	Description	State
1	Pull-up	Off
2	120 Ω termination	Off
3	Pull-down	Off
4	Not used.	Off

Figure 2.

Recommended cable : Beldon 9503, twisted multipair, screened.  
Connect the screens together at the shield / Earth pin of the PLC

## 7.1. Connection details to Allen Bradley Micrologix

13-Pin Screw Terminal Block

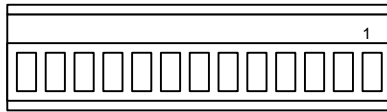

TIU100, TIU110

8-Pin Screw Terminal

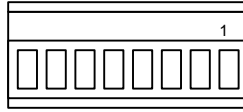

TIU050, 101, 102, 103,  
111, 112, 113, 201,  
202, 203

25-Pin D-Type Male

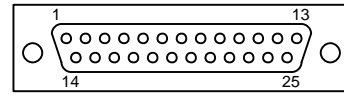

TIU300, 301, 302, 303, 304,  
310, 311, 312, 313, 314,  
320, 321, 322, 323, 324

TIU Type	13-Pin	8-Pin	25-Pin
Signal Name			
+5V	1		
TX 485/422+	2	1	12
TX 485/422-	3	2	13
RX 485/422+	4	3	24
RX 485/422-	5	4	25
TX RS232	6	5	2
Signal GND	7	6	7
RX RS232	8	7	3
Frame Gnd	13	8	1
RTS RS232	-	-	4
CTS RS232	-	-	5
RTS 485/422+	-	-	14
RTS 485/422-	-	-	17
CTS 485/422-	-	-	18
CTS 485/422+	-	-	19

### RS232 Connection

AB Micrologix  
Part No. :  
1761-CBL-PM02

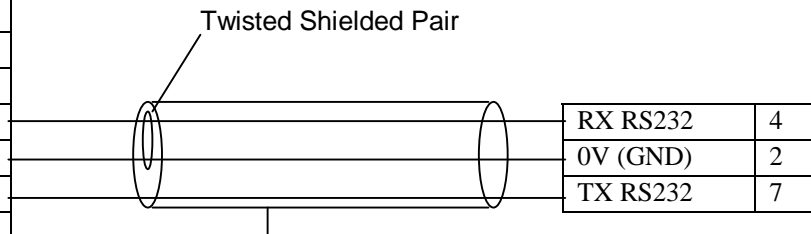

Do not connect the shield at both ends on a TIU100/110

Do not connect to unlisted pins.

Recommended cable : Beldon 9503, twisted multipair, screened.  
Connect the screens together at the shield / Earth pin of the PLC

## 7.2. Connection details to an AB SLC500 via a 1747-KE

13-Pin Screw Terminal Block

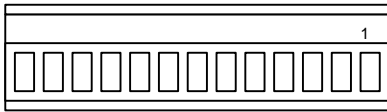

TIU100, TIU110

8-Pin Screw Terminal

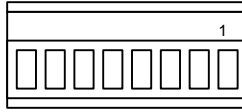

TIU050, 101, 102, 103,  
111, 112, 113, 201,  
202, 203

25-Pin D-Type Male

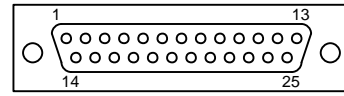

TIU300, 301, 302, 303, 304,  
310, 311, 312, 313, 314,  
320, 321, 322, 323, 324

TIU Type	13-Pin	8-Pin	25-Pin
Signal Name			
+5V	1		
TX 485/422+	2	1	12
TX 485/422-	3	2	13
RX 485/422+	4	3	24
RX 485/422-	5	4	25
TX RS232	6	5	2
Signal GND	7	6	7
RX RS232	8	7	3
Frame Gnd	13	8	1
RTS RS232	-	-	4
CTS RS232	-	-	5
RTS 485/422+	-	-	14
RTS 485/422-	-	-	17
CTS 485/422-	-	-	18
CTS 485/422+	-	-	19

### RS232 Connection

Allen Bradley  
DF1 Port  
9-Pin D-Type  
Female

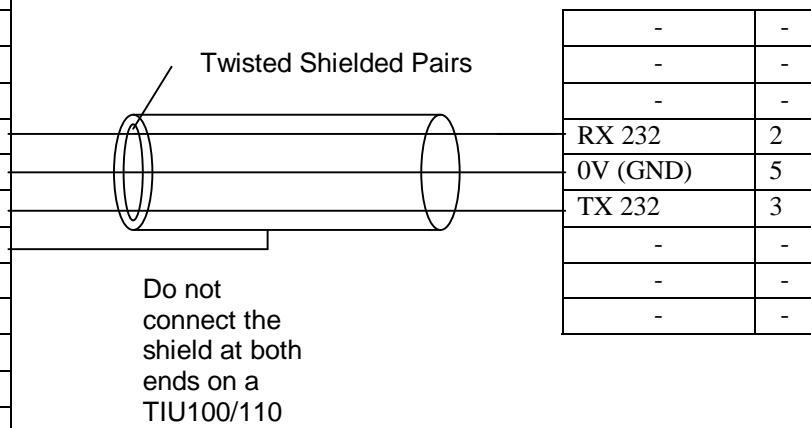

Do not connect to unlisted pins.

Recommended cable : Beldon 9503, twisted multipair, screened.  
Connect the screens together at the shield / Earth pin of the PLC

### 7.3. Connection details to AB 1770-KF2 Module / PLC5

13-Pin Screw Terminal Block

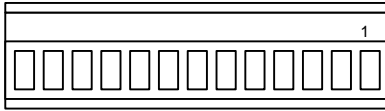

TIU100, TIU110

8-Pin Screw Terminal

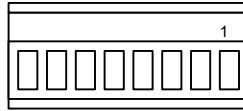

TIU050, 101, 102, 103,  
111, 112, 113, 201,  
202, 203

25-Pin D-Type Male

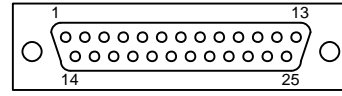

TIU300, 301, 302, 303, 304,  
310, 311, 312, 313, 314,  
320, 321, 322, 323, 324

TIU Type	13-Pin	8-Pin	25-Pin
+5V	1		
TX 485/422+	2	1	12
TX 485/422-	3	2	13
RX 485/422+	4	3	24
RX 485/422-	5	4	25
TX RS232	6	5	2
Signal GND	7	6	7
RX RS232	8	7	3
Frame Gnd	13	8	1
RTS RS232	-	-	4
CTS RS232	-	-	5
RTS 485/422+	-	-	14
RTS 485/422-	-	-	17
CTS 485/422-	-	-	18
CTS 485/422+	-	-	19

### RS232 Connection

Allen Bradley  
KF2 / PLC5 Port  
25-Pin D-Type  
Female / Male

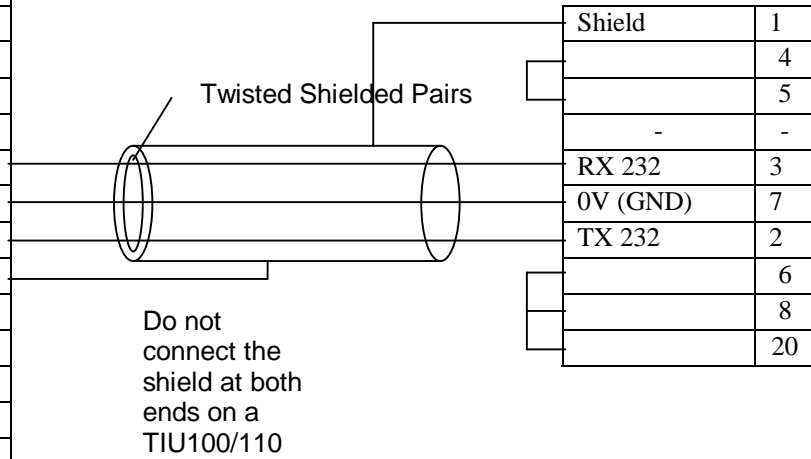

Do not connect to unlisted pins.