

QX451 to XL7 Adapter Plate (HE-XWAP4) Installation

Installing XL7 controller in QX451 panel cutout

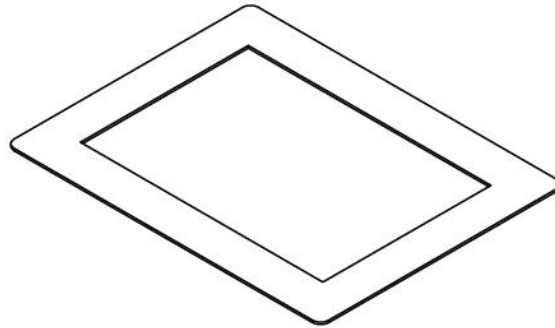

1. INTRODUCTION

The following guide describes how to install an XL7 into an existing QX451 panel cutout using the Adapter Plate Retrofit Kit (HE-XWAP4). The QX451 controller cutout is slightly larger than that of the XL7. The adapter plate adheres to the existing cutout, providing a secure and permanent edge for the XL7 installation clips to tighten to.

NOTE: DO NOT discard cardboard contained in the packaging. It is the installation insert and ensures level plate installation

2. REMOVAL OF QX451

Begin the process by removing the QX451 from the existing housing:

- 1) Disconnect all power sources, I/O, and other wiring from the existing QX451.
- 2) Loosen and remove installation clamps while supporting the controller. Generally, four are used.
- 3) Slide controller out of the front of the cutout.

3. INSTALLATION OF XL7 ADAPTER PLATE

The Adapter Plate is packaged with an attached, easy-to-use installation insert to ensure the plate is mounted evenly in the existing housing. It is recommended to test fit the adapter plate and installation insert in the existing cutout prior to the following procedure.

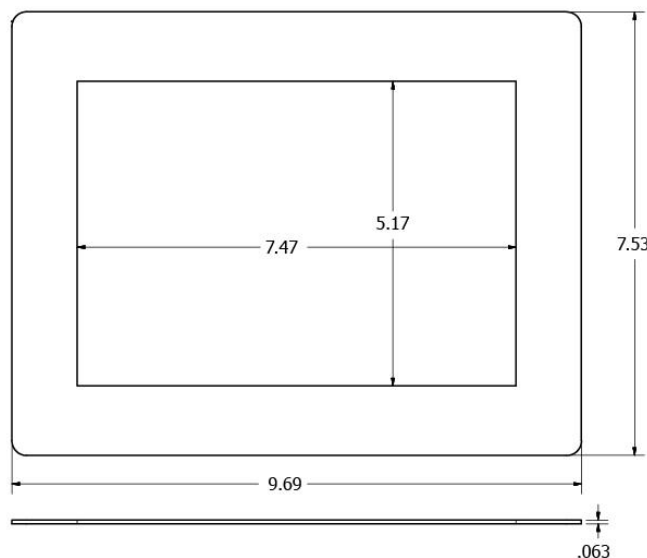

NOTE: The adhesive used forms a permanent seal. Ensure the plate will install level using the Installation insert before removing the protective film from the adhesive.

- 1) Clean 1-3 in. around the edge of the QX451 cutout rectangle with isopropyl alcohol (included in kit), removing any dust or debris
- 2) Remove protective film from the Adapter plate.
- 3) Carefully fit the installation insert through the front of the existing cutout, with adhesive facing the panel.
- 4) Firmly press the adapter plate into place, starting from the center and working out to the corners.

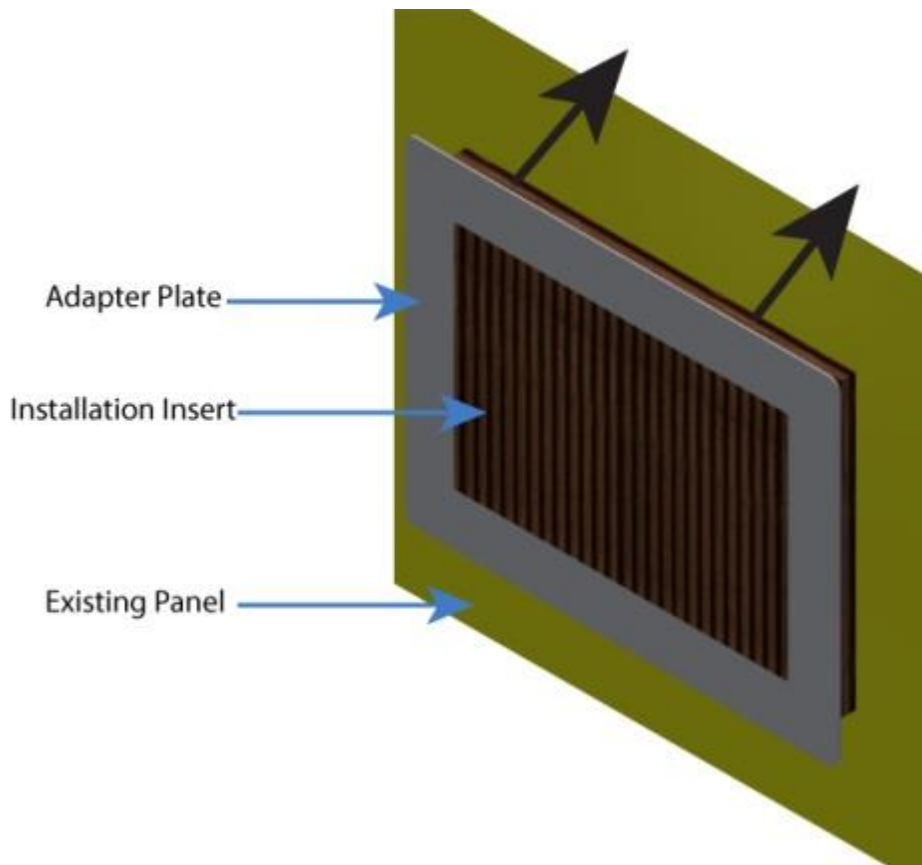

- 5) Once the plate is evenly pressed into place, push center of the installation insert through to the other side of the panel. It should pop out easily. Discard installation insert.
- 6) Adhesive should set for 5-10 mins. prior to installing controller. Adhesive reaches maximum hold in 24 hrs.

The installation clips will tighten against the newly installed adapter plate instead of the original panel cutout.

4. INSTALLATION OF XL7 CONTROLLER

- 1) Remove all connectors from the XL7 OCS unit.
- 2) Make sure the gasket is installed on the XL7 OCS and is free from dust and debris. Check that the corners of the gasket are secure.
- 3) Pass the unit through the front of the panel adapter.
- 4) Insert each of the four (4) mounting clips into the slots in the XL7 OCS case. One clip should be installed on each corner. Lightly tighten each screw so the clip is held in place.
- 5) Tighten the screws on the clips in a criss cross pattern (see below), such that the gasket is compressed against the panel evenly. Recommended torque is 7-10 lb/in (0.8-1.13 Nm.)

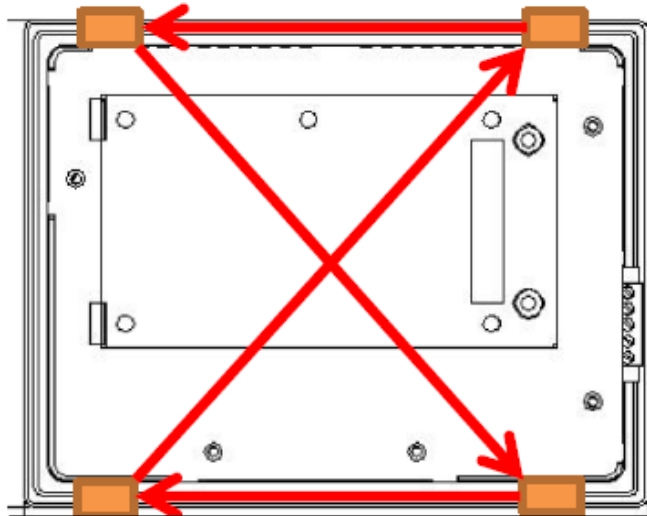

5. ADDITIONAL INFORMATION

If panel assembly takes place before shipment, clamps should be checked by hand upon arrival at installation site. Grip the side of the clamp with fingers and wiggle to check.

Minimum Clearance Requirements for Panel Box and Door	
Minimum Distance between base of device and sides of cabinet	2 inches (50.80mm)
Minimum Distance between base of device and wiring ducts	1.5 inches (38.10mm)
If more than one device installed in panel box (or on door): Minimum Distance between bases of each device	4 inches between bases of each device (101.60mm)
When door is closed: Minimum distance between device and closed door (<i>Be sure to allow enough depth for the OCS.</i>)	2 inches (50.80mm)

6. TECHNICAL SUPPORT

For assistance and manual updates, contact Technical Support at the following locations:

NORTH AMERICA

- Telephone: (317) 916-4274
- <http://www.heapg.com>
- Fax: (317) 639-4279
- Email: techspt@heapg.com

EUROPE

- Telephone: +353-21-4321266
- <http://www.horner-apg.com>
- Fax: +353-21-4321826
- Email: mailto:tech.support@horner-apg.com