



XLe / XLt GSM Modem COM Module - HE-GSM04

1 GENERAL

The GSM modem module supports the following features :

- SMS

2 SMS FUNCTIONALITY

- Up to 32 Send and 32 Receive messages with up to 20 Variables per message.
- Group Names allow multiple devices to be grouped together so that a particular message will be sent to a number of different devices.
- Phone number including country code and area code. The phone numbers may have special characters such as brackets, comma, plus and dash.
- Register numbers can be used instead of phone numbers. In this case, the phone number is stored in PLC registers as ASCII data with a maximum size of 20 chars (10 words).
- Bit, Byte, Word, Double Word and Real variable types supported.
- 64-bit Status word includes communication status, Initialization status, signal strength, invalid messages count and Retry count for Init commands
- 160 character message buffer stores last sent or received message.

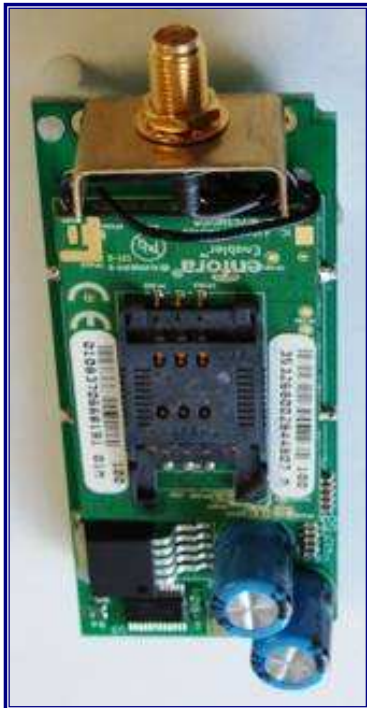

3 INSTALLATION / SAFETY

When found on the product, the following symbols specify:

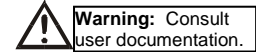
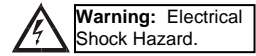

WARNING: To avoid the risk of electric shock or burns, always connect the safety (or earth) ground before making any other connections.

WARNING: To reduce the risk of fire, electrical shock, or physical injury it is strongly recommended to fuse the voltage measurement inputs. Be sure to locate fuses as close to the source as possible.

WARNING: Replace fuse with the same type and rating to provide protection against risk of fire and shock hazards.

WARNING: In the event of repeated failure, do not replace the fuse again as a repeated failure indicates a defective condition that will not clear by replacing the fuse.

WARNING: Only qualified electrical personnel familiar with the construction and operation of this equipment and the hazards involved should install, adjust, operate, or service this equipment. Read and understand this manual and other applicable manuals in their entirety before proceeding. Failure to observe this precaution could result in severe bodily injury or loss of life.

WARNING: To comply with FCC RF exposure requirements, a separation distance of 20 cm (7.87") or more must be maintained between this antenna and all persons.

WARNING: Maximum antenna gain is limited to 3 dBi* in mobile products and applications. Maximum antenna gain is limited to 7 dBi* in fixed products and applications.

All applicable codes and standards must be followed during the installation of this product.

Adhere to the following safety precautions whenever any type of connection is made to the module:

- Connect the safety (earth) ground on the power connector first before making any other connections.
- When connecting to electric circuits or pulse-initiating equipment, open their related breakers.
- Do not make connections to live power lines.
- Make connections to the module first; then connect to the circuit to be monitored.
- Route power wires in a safe manner in accordance with good practice and local codes.
- Wear proper personal protective equipment including safety glasses and insulated gloves when making connections to power circuits.
- Ensure hands, shoes, and floor are dry before making any connection to a power line.
- Make sure the unit is turned OFF before making connection to terminals.
- Make sure all circuits are de-energized before making connections.
- Before each use, inspect all cables for breaks or cracks in the insulation. Replace immediately if defective.

WARNING

To comply with FCC RF exposure requirements, a separation distance of 20 cm (7.87") or more must be maintained between this antenna and all persons

Enfora certifies that the Enfora Enabler III-G™ MHz GSM Radio Module (FCC ID: MIVGSM0308) complies with the RF hazard requirements applicable to broadband PCS equipment operating under the authority of 47 CFR Part 22 or Part 24, Subpart E of the FCC Rules and Regulations.

This certification is contingent upon installation, operation and use of the Enfora Enabler III-G module and its host product in accordance with all instructions provided to both the OEM and end user. When installed and operated in a manner consistent with the instructions provided, the Enfora Enabler III-G module meets the maximum permissible exposure (MPE) limits for general population / uncontrolled exposure as defined in Section 1.1310 of the FCC Rules and Regulations.

Maximum antenna gain is limited to 2 dBi* in mobile products and applications

For fixed applications (2 meter separation) the antenna gain can be as much as 26 dBi.

Modifications and/or additions to the Enfora Enabler III-G GSM transceiver, including use of antennas with higher gain than those authorized by the FCC, are prohibited.

*dBi = antenna gain in dB relative to an isotropic radiator

Any antenna used with the modem must be approved by the FCC or as a Class II Permissive Change (including MPEL or SAR data as applicable). The "professional installation" provision of FCC Part 15.203 does not apply.

WARNING

The transmitter and antenna must not be collocated or operating in conjunction with any other antenna or transmitter. Failure to observe this warning could produce an RF exposure condition.

4 SPECIFICATIONS

HE-GSM04 SPECIFICATIONS			
Antenna Interface	Female SMA.		
Frequency bands	EGSM 900, DCS 1800, and PCS 1900, GSM 850 capability.		
GSM/GPRS features supported	Provides for all GSM/GPRS authentication, encryption, and frequency hopping algorithms. GPRS Coding Schemes CS1-CS4 supported. Multi-Slot Class 10 (4RX/2TX, Max 5 Slots).		
Regulatory Agency approvals	GCF Type Approval PTCRB Type Approval FCC Certification (Part 24) RTTE CE (European Community Certification) IC (Industry Canada) Approval		
GSM/GPRS Functionality	Mobile-originated and mobile-terminated SMS messages: up to 140 bytes or up to 160 GSM 7-bit ASCII characters. Reception of Cell Broadcast Message SMS Receipt acknowledgement Circuit Switched Data (Transparent & Non-transparent up to 9.6 Kbps) Voice (EFR, FR, HR) Supports Unstructured Supplementary Service Data (USSD) Multi-Slot Class 10 Supported (4Rx/2Tx), (5 Slot Max) PBCCCH/PCCCH Supported.		
SIM	3 V Mini-Subscriber Identity Module (SIM) compatible		
Size (L x W)	82.3 mm x 34.6 mm x 3.1 mm		
Weight	Less than 80 grams		
Operating & Storage temperature	0°C to +60°C (Operating) -10°C to +85°C (Storage)		
Relative humidity	5 - 95%		
Air pressure (altitude)	70 kPa to 106 kPa (-400 m to 3000 m)		
Transmit Power	Frequency	Power Class	Transmit Power
	1900 MHz 1800 MHz	GSM Power Class 1	1-W conducted power maximum (30 dBm +/- 2 dB), measured at the antenna port
	850 MHz 900 MHz	GSM Power Class 4	2-W conducted power maximum (33 dBm +/- 2 dB), measured at the antenna port
Receive Power	Frequency	Sensitivity	Mode
	1900 MHz 1800 MHz	-106 dBm (typical)	GPRS Coding Scheme 1 (CS1)
	850 MHz 900 MHz	-106 dBm (typical)	GPRS Coding Scheme 1 (CS1)

5. OPERATING INSTRUCTIONS

5.1 INTRODUCTION

The HE-GSM04 utilizes the same internal communications channel (UART) as the MJ1 serial port; thus, enabling the modem deactivates the MJ1 serial port. However, support is provided to select which device (or port) is currently active.

5.2 INSTALLATION PROCEDURE

1. Disconnect all power from the XLE unit including I/O power.
2. Remove the four screws on the back of the XLE unit and remove the back cover. The back cover will be replaced with the extended back cover that ships with the communication add-on. Screws are re-used (Figure 1).
3. Plug the communication board onto the 24-pin connector. Make sure all the pins are properly aligned (Figure 2).
4. Place the extended back cover onto the unit. It can be helpful to tip it at an angle so the connector on the COM board passes through the opening on the back cover.
5. Place the screw back into the hole and turn the screw slowly counter clockwise until it clicks into the threads. This prevents the screw from being cross-threaded. Now, turn the screw clock-wise until the cover is firmly secured. Repeat this process for all four (4) screws.

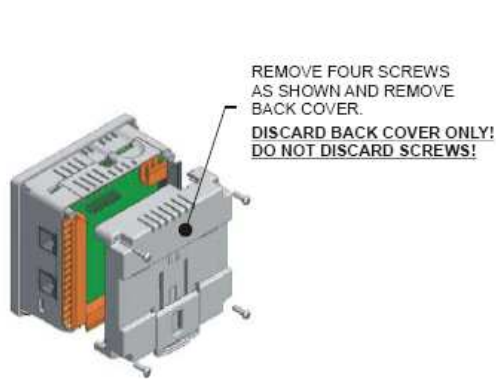

REMOVE FOUR SCREWS AS SHOWN AND REMOVE BACK COVER.
DISCARD BACK COVER ONLY! DO NOT DISCARD SCREWS!

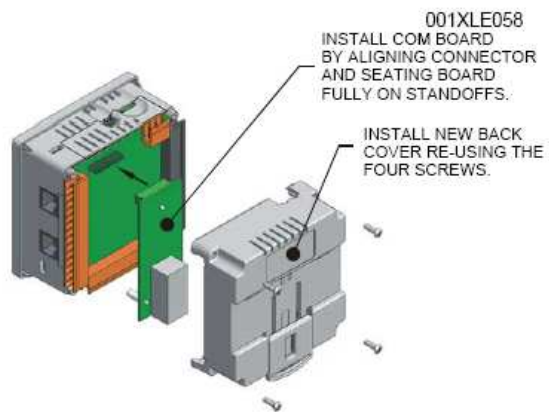

001XLE058
 INSTALL COM BOARD BY ALIGNING CONNECTOR AND SEATING BOARD FULLY ON STANDOFFS.

INSTALL NEW BACK COVER RE-USING THE FOUR SCREWS.

Figure 1 - Removing Back Cover of the XLE

Figure 2 - Installing the COM Board in the XLE

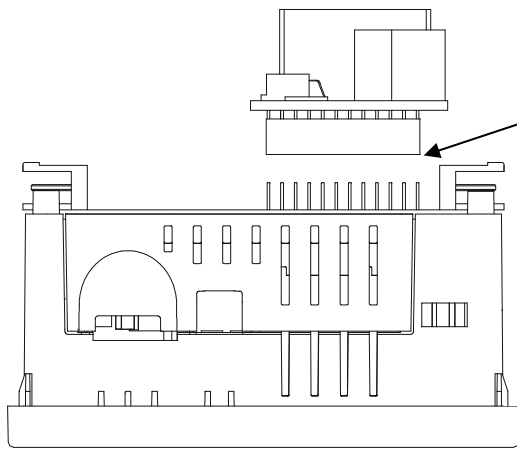





Warning : Be careful when installing the module to align the connector properly. Mis-alignment will damage the module.

Add the foam strip to the antenna support as shown, on both sides and across the top.

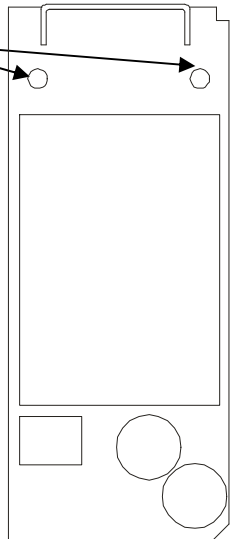

Add Support Standoffs from the kit.



Standoff	Model used on
	Preferred standoff, use this if the I/O board has the mounting holes.
	Use this if the I/O board does not have the mounting holes.
	Use this if the I/O board does not have the mounting holes and the GSM module is Rev A-C

6 TECHNICAL SUPPORT

For assistance and manual updates, contact Technical Support at the following locations:

North America:
 Tel: 317 916-4274
 Fax: 317 639-4279
 Web: <http://www.heapg.com>
 Email: techsppt@heapg.com

Europe:
 Tel: +353-21-4321266
 Fax: +353-21-4321826
 Web: <http://www.horner-apg.com>
 Email: tech.support@horner-apg.com

No part of this publication may be reproduced without the prior agreement and written permission of Horner APG, Inc. Information in this document is subject to change without notice.