

XL15+ Datasheet - Model 2

12 DC In, 6 Relay Out, 4 – 12-bit Analog In

MAN1125 Revision 20

25 MAY 2023



HG-003

Part Numbers

Global Part Number	HE-XP7E2
European Part Number	HEXT751C112

User Manual and Add-Ons

Find the documents via the [Documentation Search](#).

Part #	Description
MAN1106	XL15+ User Manual
MAN1142	Rechargeable Battery Manual
HE-BAT019	Rechargeable 3.6V Lithium Battery
HE-XCK	Programming Cables
HE-XDAC007	2 channel Analog Output I/O option kit, selectable 0-10V, +/-10V, 4-20mA.
HE-XDAC107	4 channel Analog Output I/O option kit, selectable 0-10V, +/-10V, 4-20mA.
HE-XKIT	Blank I/O Board
HE200MJ2TRM	Adapter, RJ45 (8P8C) male to 8-position terminal strip.
HE-FBD001	Ferrite core for filtering out electrical noise.

Battery Maintenance

The XL15+ uses a Renata CR2032 lithium battery to run the Real-Time Clock and to maintain the retained register values. This battery is designed to maintain the clock and memory for 7-10 years. Please reference **MAN1106** providing instructions on how to replace the battery.

Table of Contents

User Manual and Add-Ons	1
Battery Maintenance	1
MODEL 2 SPECIFICATIONS	2
General Specifications	2
Display	2
Connectivity	2
Control and Logic	3
High Speed Inputs	3
USB Webcams	3
XL15+ User Manual [MAN1106]	3
Digital DC Input	4
Digital Relay Outputs	4
Analog Inputs, Medium Resolution	5
CONTROLLER OVERVIEW	6
Port Controllers	6
Power Wiring	7
WIRING: INPUTS AND OUTPUTS	8
Digital Inputs	8
Relay Out	8
Analog Input	9
Jumper Settings for Model 2	9
Back Panel Torque Rating	9
Wiring Details	10
J1 Wiring - Digital In/Analog In	10
J2 Wiring - Relay Out/Analog or Digital In	11
Built-In I/O	12
Analog Input Tranzorb Failure	12
COMMUNICATIONS	13
Serial Communications	13
Ethernet	14
CAN Communications	14
DIMENSIONS & INSTALLATION	15
Installation Procedure	16
SAFETY & MAINTENANCE	17
Warnings	17
FCC Compliance	17
Technical Support	17
Precautions	18

MODEL 2 SPECIFICATIONS

General Specifications

Required Power (Steady State)	2081mA @ 10V (20.81W) 857mA @ 24V (8.57W)
Heater Option	800mA @ 24VDC
Power Backlight 50%	385mA (9.6W)
Power Backlight Off	290mA (7W)
Inrush Current	25A for < 1ms @ 24VDC DC
Primary Pwr. Range	18–30VDC
Clock Accuracy	+/- 20 ppm maximum at 25°C (+/- 1 min/month)
Real Time Clock	With Battery (5-10 Yrs life, Replaceable)
Relative Humidity	5 to 95% non-condensing
Operating Air Temp	-10°C to +60°C
Storage Temp	-30°C to +70°C
Weight	7.63 lbs/3.46 kg (without I/O)
Certifications (UL/CE)	North America or Europe

Display

Display Type	15" XGA TFT (500 cd/m ² typical)
Resolution	1024 x 768
Color	24-bit (16,777,216)
Built-In Storage	4 GB
User-Program Screens	1023 max pages; 1023 objects per page
Backlight	LED - 50,000 hour life
Brightness Control	0-100% via System Register
Touchscreen	Resistive w/laminated cover, 1,000,000+ touch life

Connectivity

3x Serial Ports	RS-232 full handshaking or RS-485 half duplex on first Modular Jack (MJ1) RS-232 or RS-485 on second Modular Jack (MJ2) RS-232 or RS-485 on third Modular Jack (MJ3)(Software Controlled RS-485 Termination/Biasing)
USB mini-B	USB 2.0 (480 Mbps) Programming & Data Access
3x USB A (500mA max)	USB 2.0 (480 Mbps) for USB flash drives (2TB)
2x CAN	125 kbps – 1 Mbps, Remote I/O, Peer-to- Peer Comms, Cscape (Isolated Ports)
2 x Ethernet	1 Gb (Auto-MDX), Modbus TCP C/S, HTTP, FTP, SMTP, Cscape, Ethernet IP
Remote I/O	SmartRail, SmartStix, SmartBlock, SmartMod
Removable Memory	microSD, SDHC, SDXC IN FAT32 format, support for 128 GB max. Application Updates, Datalogging, more
Audio	Beeper, Mic In, Line Out



Control and Logic

Control Lang. Support	Advanced Ladder Logic Full IEC 1131-3 Languages
Logic Program Size & Scan Rate	2MB
Logic Scan Rate	.006ms/kB
Online Programming Changes	Supported in Advanced Ladder
Digital Inputs	2048
Digital Outputs	2048
Analog Inputs	512
Analog Outputs	512
Gen. Purpose Registers	49,999 (words) Retentive 16,384 (bits) Retentive 16,384 (bits) Non-retentive

High Speed Inputs

Number of Counters	4
Maximum Frequency	1MHz Max
Accumulator Size	32-bits each
Modes Supported	Totalizer, quadrature, pulse measurement, frequency measurement, set-point controlled outputs

USB Webcams

USB Webcams supported should support the UVC (USB Video class) protocol for the OCS to be able to display video. Most USB based video devices support this today. Special feature such as zoom and high definition are not supported by the OCS.

XL15+ User Manual [MAN1106]

USB Webcams supported should support the UVC (USB Video class) protocol for the OCS to be able to display video. Most USB based video devices support this today. Special feature such as zoom and high definition are not supported by the OCS.

The User Manual includes extensive information on:

- Built-in I/O
- I/O Status and Calibration
- Common %S & %SR Registers
- HSC/PWM/Totalizer/Quadrature & Accumulator Registers
- Resource Limits

Digital DC Input

Inputs per Module	12 including 4 configurable HSC inputs	
Commons per Module	1	
Input Voltage Range	12VDC/24VDC	
Absolute Max. Voltage	30VDC Max.	
Input Impedance	10k Ω	
Input Current	Positive Logic	Negative Logic
Upper Threshold Lower Threshold	0.8mA 0.3mA	-1.6mA -2.1mA
Max. Upper Threshold	8VDC	
Min. Lower Threshold	3VDC	
OFF to ON Response	1ms	
ON to OFF Response	1ms	
High Speed Counter Max Freq*	1MHz Max	

*See I/O info below for detail regarding HSC and PWM

Digital Relay Outputs

Outputs per Module	6 Relay
Commons per Module	6
Max. Output Current per Relay	3A @ 250VAC, resistive
Max. Total Output Current	5A continuous
Max. Output Voltage	275VAC, 30 VDC
Max. Switched Power	1000VAC, 150W
Contact Isolation to Ground	1000VAC
Max. Voltage Drop at Related Current	0.5V
Expected Life (see below derating chart for details)	No Load: 5,000,000 Rated Load: 100,000
Max. Switching Rate	300 CPM at no load 20 CPM at rated load
Type	Mechanical Contact
Response Time	One update per ladder scan plus 10ms

Analog Inputs, Medium Resolution

Number of Channels	4
Input Ranges	0-10VDC, 0-20mA, 4-20mA
Safe Input Voltage Range	-0.5V to 12V
Input Impedance (clamped @ -0.5VDC to 12VDC)	Current Mode: 100Ω Voltage Mode: 500kΩ
Nominal Resolution	12 Bits
%AI Full Scale	0V, 20mA, 100mV: 32,000 counts full scale
Max. Over Current	35mA
Conversion Speed	Once per Logic Scan
Max Error at 25°C (excluding Zero) Adjusting Filtering may tighten	4-20mA 1.00% 0-20mA 1.00% 0-10VDC 1.50%
Filtering	160Hz Hash (noise) Filter, 1-128 Scan Digital Running Average Filter

CONTROLLER OVERVIEW

Port Controllers



HG-004

1. Virtual Function Keys Slide in from the Right Upon Touching Top Right Corner of Screen
2. Optional Built-In I/O
3. High Capacity microSD Slot
4. USB Mini-B Port
5. Dual CAN Port
6. USB A Ports (3)
7. Mic Input / Audio Output
8. Dual Ethernet LAN Port
9. Mini Display Port Video Output
10. Wide-Range DC Power
11. Dual CAN Port
12. RS232/RS485 Serial Ports (3)

NOTE: See Precaution #12 on page 4 about USB and grounding.

Power Wiring

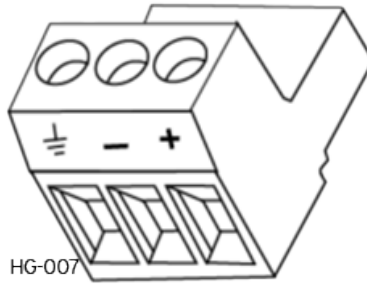

Primary Power Port Pins		
PIN	Signal	Description
1	Ground	Frame Ground
2	DC-	Input Power Supply Ground
3	DC+	Input Power Supply Voltage

DC Input/Frame

- Solid/Stranded Wire: 12-24 awg (2.5-0.2mm)
- Strip length: 0.28" (7mm)
- Torque Rating: 4.5 – 7 in-lbs (0.50 – 0.78 N-m)

DC- is internally connected to I/O V-, but is isolated from CAN V-. A Class 2 power supply must be used.

Power Up

1. Attach ferrite core with a minimum of two turns of the DC+ and DC- signals from the DC supply that is powering the controller.



2. Connect to earth ground.
3. Apply recommended power.

WIRING: INPUTS AND OUTPUTS

Digital Inputs

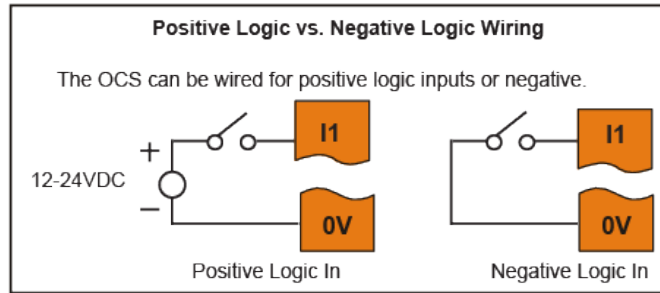

HG-033

Digital inputs may be wired in either a Positive Logic or Negative Logic fashion as shown. The setting in the Cscape Hardware Configuration for the Digital Inputs must match the wiring used in order for the correct input states to be registered. No jumper settings are required for XL+. When used as a normal input and not for high speed functions, the state of the input is reflected in registers %I1 – %I12.

Digital inputs may alternately be specified for use with High Speed Counter functions, also found in the Hardware Configuration for Digital Inputs. Refer to the XL+ User Manual (MAN1106) for full details.

Relay Out

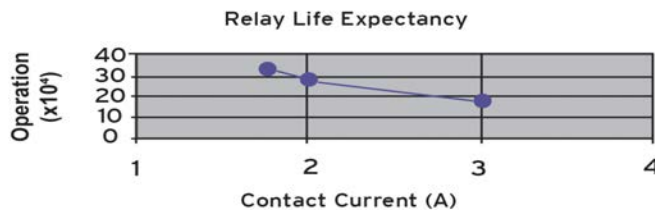

HG-046

Exposure to some chemicals may degrade the sealing proper- ties of materials used in the Tyco relay PCJ.

Cover/Case & Base: Mistubishi engineering Plastics Corp. 5010GN6-30 or 5010GN6-30 M8 (PBT)

Sealing Material: Kishimoto 4616-50K (I part epoxy resin)

It is recommended to periodically inspect the relay for any degradation of properties and replace if necessary.

Analog Input

Raw input values for channels 1-4 are found in the registers as Integer- type data with a range from 0 – 32000.

Analog inputs may be filtered digitally with the Filter Constant found in the Cscape Hardware Configuration for Analog Inputs. Valid filter values are 0-7 and act according to the following chart:

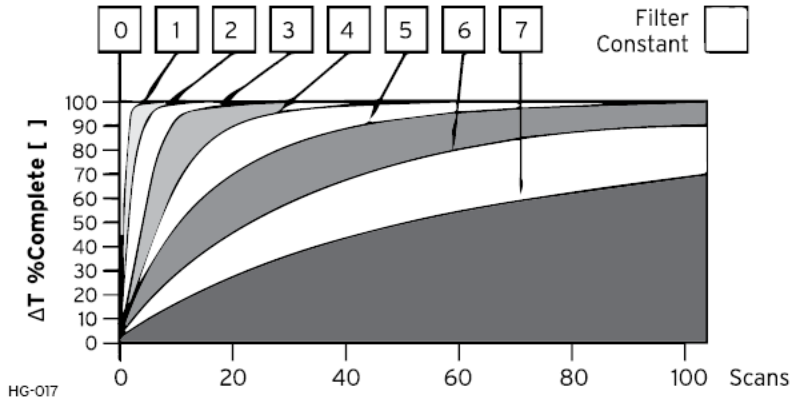

Data Values	
Input Mode:	Data Format, 12-bit INT:
0-20mA, 4-20mA	0-32000
0-10V	0-32000

Jumper Settings for Model 2

Location of I/O jumpers (JP1 & JP2) and wiring connectors (J1 & J2) with back cover removed.

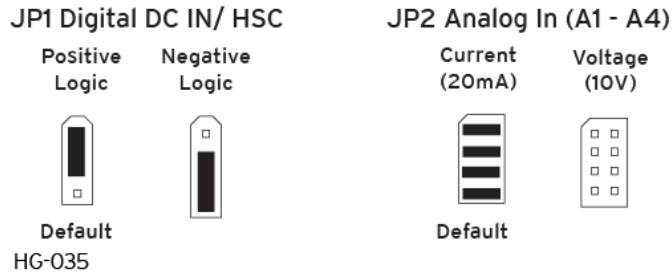

NOTE: The Cscape Module Configuration must match the selected I/O (JP) jumper settings.
(Cscape Path: **Controller -> Hardware Configuration -> Local I/O -> Config -> Module Setup -> Analog In**)

NOTE: When using JP2 (A1-A4), each channel can be independently configured.

Back Panel Torque Rating

XL15+: 3.0 - 3.5 in-lbs (0.34 - 0.40 N-m)

Wiring Details

Solid/Stranded Wire: 12-24 awg (2.5-0.2mm²).

Strip Length: 0.28" (7mm).

Torque, Terminal Hold-Down Screws: 4.5 – 7 in-lbs (0.50 – 0.78 N-m).

J1 Wiring - Digital In/Analog In

J1 (Orange)	Name
I1 (%I1)	Digital In 1
I2 (%I2)	Digital In 2
I3 (%I3)	Digital In 3
I4 (%I4)	Digital In 4
I5 (%I5)	Digital In 5
I6 (%I6)	Digital In 6
I7 (%I7)	Digital In 7
I8 (%I8)	Digital In 8
H1	HSC1 / Dig In. 9
0V	Common
A1 (%AI1)	Analog In 1
A2 (%AI2)	Analog In 2
A3 (%AI3)	Analog In 3
A4 (%AI4)	Analog In 4
0V	Common

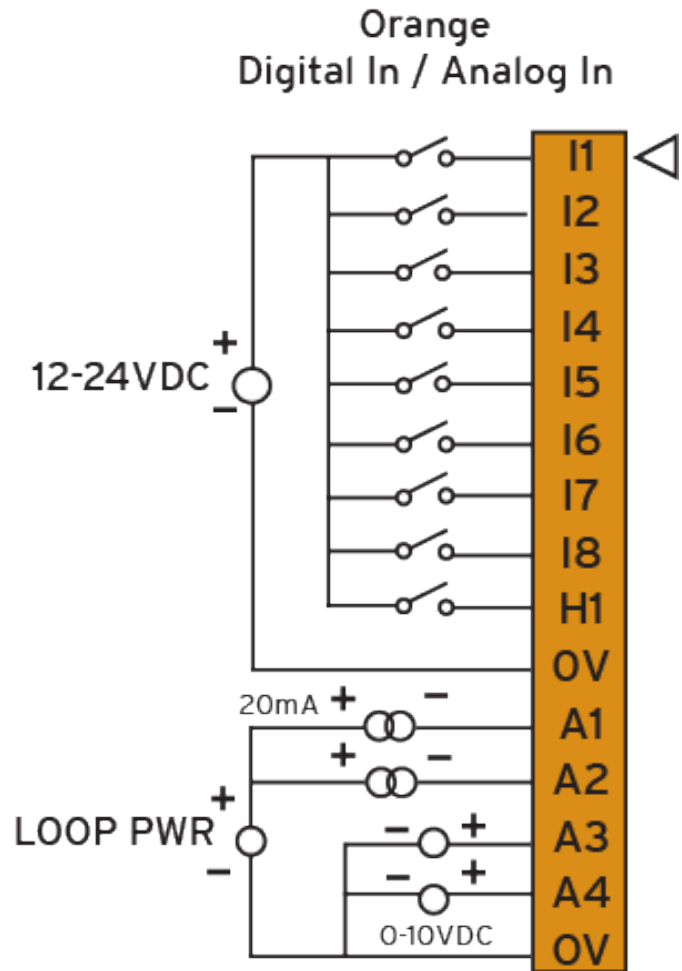

HG-036

NOTE: The 0V terminals are internally connected.

20mA Analog In - Not Self Powered

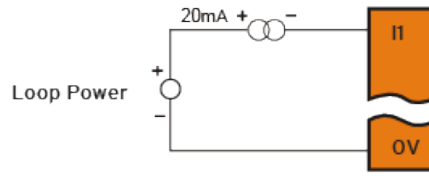

20mA Analog In - Self Powered

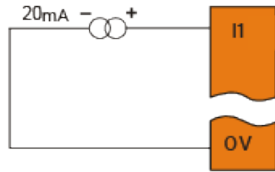

HG-022

0-10VDC IN

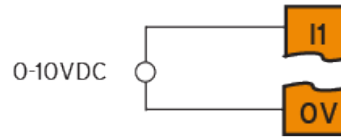

J2 Wiring - Relay Out/Analog or Digital In

J2 (Black) Name	
C6 (%Q6)	Relay 6 COM
R6 (%Q6)	Relay 6 NO
C5 (%Q5)	Relay 5 COM
R5 (%Q5)	Relay 5 NO
C4 (%Q4)	Relay 4 COM
R4 (%Q4)	Relay 4 NO
C3 (%Q3)	Relay 3 COM
R3 (%Q3)	Relay 3 NO
C2 (%Q2)	Relay 2 COM
R2 (%Q2)	Relay 2 NO
C1 (%Q1)	Relay 1 COM
R1 (%Q1)	Relay 1 NO
H4 (%I12)	HSC4 / Dig. In 12
H3 (%I11)	HSC3 / Dig. In 11
H2 (%I10)	HSC2 / Dig. In 10

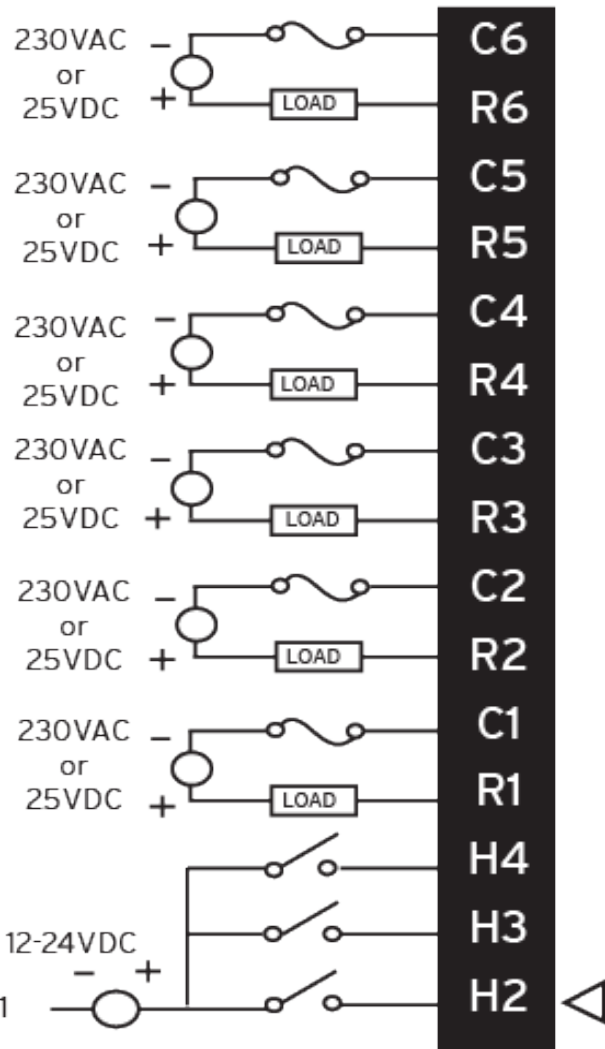

HG-037

Built-In I/O

All XL15+ models (except the HE-XP7E0) feature built-in I/O. The I/O is mapped into OCS Register space, in three separate areas – Digital/Analog I/O, High-Speed Counter I/O, and High-speed Output I/O. Digital/Analog I/O location is fixed starting at 1, but the high-speed counter and highspeed output references may be mapped to any open register location. For more details on using the high-speed counter and high-speed outputs, see the XL15+ OCS User's Manual (MAN1106).

Digital and Analog I/O Functions	
Digital Inputs	%I1-12
Reserved	%I13-32
ESCP Alarm	n/a
Digital Outputs	%Q1-6
Reserved	%Q7-24
Analog Inputs	%AI1-4
Reserved	%AI5-12
Analog Outputs	n/a
Reserved	n/a

Analog Input Transorb Failure

A common cause of Analog Input Transorb Failure on Analog Inputs. If a 4- 20mA circuit is initially wired with loop power, but without a load, the Analog input could see 24VDC. This is higher than the rating of the transorb. This can be solved by NOT connecting loop power prior to load connection, or by installing a low-cost PTC in series between the load and Analog input.

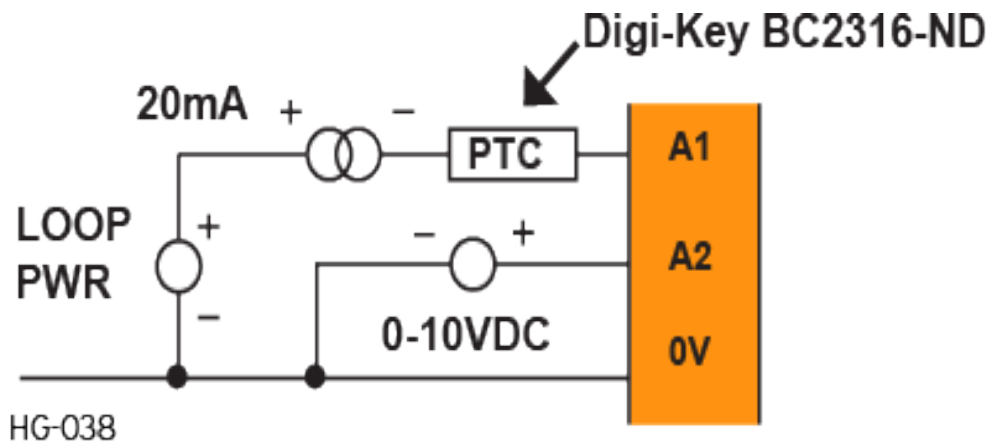

COMMUNICATIONS

Serial Communications

MJ1 Serial Ports

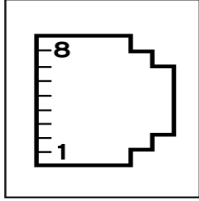

HG-008

MJ1: RS-232 w/full handshaking or RS-485 half-duplex via software switch
RS-485 termination and biasing via software

MJ1 PINS		
PIN	SIGNAL	DIRECTION
8	TXD	OUT
7	RXD	IN
6	0V	GROUND
5	+5V @ 60mA	OUT
4	RTS	OUT
3	CTS	IN
2	RX-/TX-	IN/OUT
1	RX+/TX+	IN/OUT

MJ2/3 Serial Ports

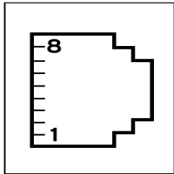

HG-008

MJ2/3: RS-232 or RS-485 half or full-duplex, software selectable RS-485
termination and biasing, software selectable

MJ2/3 PINS		
PIN	SIGNAL	DIRECTION
8	TXD RS232	OUT
7	RXD RS232	IN
6	0V	GROUND
5	+5V @ 60mA	OUT
4	TX- RS485	OUT
3	TX+ RS485	OUT
2	RX- RS485	IN
1	RX+ RS485-	IN

NOTE: Attach optional [ferrite core](#) with a minimum of two turns of serial cable. See website for more details.
[Part #: HE-FBD001]

Ethernet

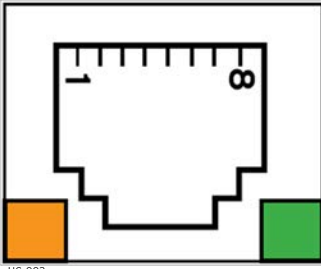

HG-002

Green LED indicates link - when illuminated, data communication is available.

Orange LED indicates activity - when flashing, data is in transmission.

CAN Communications

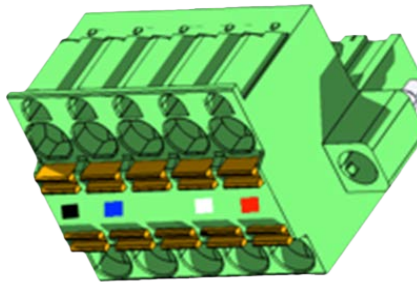

HG-001

CAN Pin Assignments		
PIN	SIGNAL	DESCRIPTION
1	V-	CAN Ground – Black
2	CN_L	CAN Data Low – Blue
3	SHLD	Shield Ground – None
4	CN_H	CAN Data High – White
5	V+ (NC)	No Connect – Red

- **Solid/Stranded Wire:** 12-24 awg (2.5-0.2mm).
- **Strip Length:** 0.28" (7mm).
- Locking spring-clamp, two-terminators per conductor.
- **Torque, Terminal Hold-Down Screws:** 4.5 – 7 in-lbs (0.50 – 0.78 N-m).

V+ pin is not internally connected, the SHLD pin is connected to Earth ground via a 1MΩ resistor and 10 nF capacitor.

DIMENSIONS & INSTALLATION

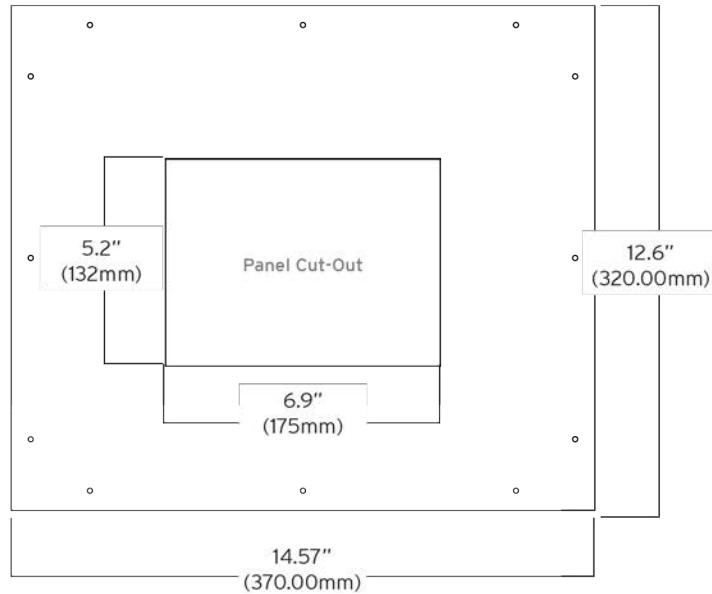
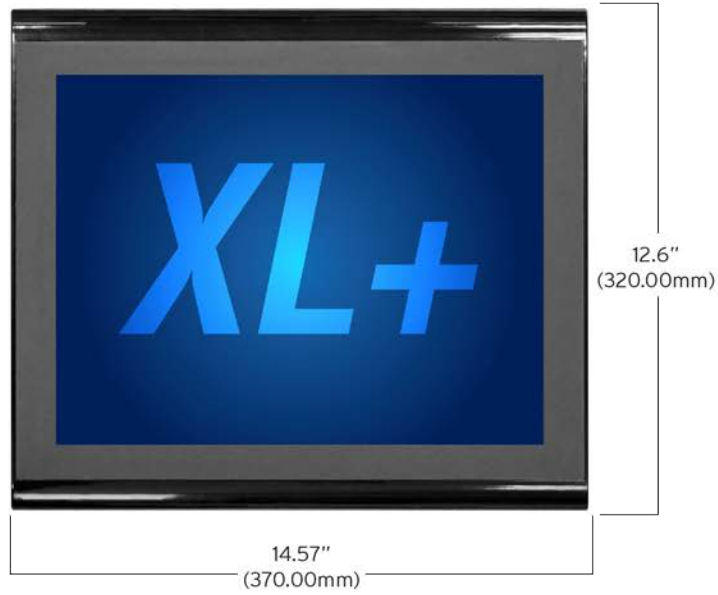

Panel Tolerance: +/-0.5mm
HG-005

NOTE: For mounting template, please refer to MAN1124.

Installation Procedure

The XL15+ is a panel mounted device and is meant to be an enclosure suitable for the equipment, such that the equipment is only accessible with the use of a tool. The XL15+ is suitable for use in Class I, Division II, Groups F and G, and Class III Hazardous Locations or non-hazardous locations only.

The XL15+ allows unique installation options that simplify installation for systems that may not need robust vibration or water resistance.

If the system does not experience shock or vibration and will not be exposed to weather or wash down conditions the unit can be installed by cutting the rectangular opening and installing the four supplied clips.

For systems that may experience shock or vibration or are installed outdoors or in wash down environments, the rectangular cut and clips are used and perimeter holes must be drilled in the panel. The supplied studs are then inserted into the perimeter of the controller and supplied nuts will secure the perimeter of the unit to the panel.

Please reference the XL15+ Quick Reference Guide (MAN1124) for Mounting Template.

1. Remove all connectors from the XL15+ OCS unit.
2. Carefully locate an appropriate place to mount the XL+. Be sure to leave enough room at the top of the unit for insertion and removal of the microSD card. Also leave enough room at the bottom for the insertion and removal of USB FLASH drives and wiring
3. Carefully cut the host panel per the diagram, with a tolerance of +/- 0.5mm. Remove any burrs/sharp edges and ensure the panel is not warped in the cutting process.
 - If the opening is too large, water may leak into the enclosure, potentially damaging the OCS.
 - If the opening is too small, the OCS may not fit through the hole without damage.
4. Make sure both inner and outer gaskets are installed on the XL15+ OCS and are free from dust and debris. Check that the corners of the gasket are secure. Insert the OCS through the panel cutout (from the front). The gasket needs to be between the host panel and the OCS.
5. The two (2) spring clips will latch the unit in the panel.
6. Insert each of the four (4) mounting clips into the slots in the XL15+ OCS case. One clip should be installed on each corner. Lightly tighten each screw so the clip is held in place.
7. Tighten the screws on the clips such that the gasket is compressed against the panel. Recommended torque is 7-10 in-lbs (0.79-1.13 Nm). If the perimeter studs are needed, it is recommended to use a thread locker (similar to 242 Blue Loctite). Use supplied lock washers and nut.

NOTE: Recommended torque is 3-4 in-lbs (0.34- 0.45 Nm).

8. Reinstall the I/O Removable Terminal Blocks.
Connect communications cables to the serial port, USB ports, Ethernet port, and CAN port as required.

SAFETY & MAINTENANCE

Warnings

1. To avoid the risk of electric shock or burns, always connect the safety (or earth) ground before making any other connections.
2. To reduce the risk of fire, electrical shock, or physical injury, it is strongly recommended to fuse the voltage measurement inputs. Be sure to locate fuses as close to the source as possible.
3. Replace fuse with the same type and rating to provide protection against risk of fire and shock hazards.
4. In the event of repeated failure, do NOT replace the fuse again as repeated failure indicates a defective condition that will NOT clear by replacing the fuse.
5. Only qualified electrical personnel familiar with the construction and operation of this equipment and the hazards involved should install, adjust, operate, or service this equipment.
6. Read and understand this manual and other applicable manuals in their entirety before proceeding. Failure to observe this precaution could result in severe bodily injury or loss of life.
7. **WARNING** - Battery may explode if mistreated. Do not recharge, disassemble, or dispose of in fire.
8. **WARNING - EXPLOSION HAZARD** - Batteries must only be changed in an area known to be non-hazardous.
9. **WARNING** - Do not disconnect while circuit is live unless are is know to be non-hazardous.

FCC Compliance

This device complies with Part 15 of the FCC Rules. Operation is subject to the following two conditions:

1. This device may not cause harmful interference.
2. This device must accept any interference received, including interference that may cause undesired operation.

Technical Support

North America

1 (317) 916-4274

(877) 665-5666

www.hornerautomation.com

techsppt@heapg.com

Europe

+353 (21) 4321-266

www.hornerautomation.eu

technical.support@horner-apg.com

Precautions

All applicable codes and standards need to be followed in the installation of this product. Adhere to the following safety precautions whenever any type of connection is made to the module:

1. Connect the safety (earth) ground on the power connector first before making any other connections.
2. When connecting to the electric circuits or pulse-initiating equipment, open their related breakers.
3. Do NOT make connection to live power lines.
4. Make connections to the module first; then connect to the circuit to be monitored.
5. Route power wires in a safe manner in accordance with good practice and local codes.
6. Wear proper personal protective equipment including safety glasses and insulated gloves when making connections to power circuits.
7. Ensure hands, shoes, and floor are dry before making any connection to a power line.
8. Make sure the unit is turned OFF before making connection to terminals.
9. Make sure all circuits are de-energized before making connections.
10. Before each use, inspect all cables for breaks or cracks in the insulation. Replace immediately if defective.
11. Use copper conductors in Field Wiring only, 60/75°C.
12. Use caution when connecting controllers to PCs via serial or USB. PCs, especially laptops, may use "floating power supplies" that are ungrounded. This could cause a damaging voltage potential between the laptop and controller. Ensure the controller and laptop are grounded for maximum protection. Consider using a USB isolator due to voltage potential differences as a preventative measure.