

X7 Micro OCS Datasheet

Model A Built-In I/O: 12 Digital In, 12 Digital Out, 4 Analog In/RTD IN, 2 Analog Out

Model R Built-In I/O: 12 Digital In, 6 Relay Out, 2 PWM Out, 4 Analog In/RTD In, 2 Analog Out

MAN1155-20_X7_DS



Table of Contents

Part Numbers	1
User Manual and Add-Ons	1
Battery Maintenance	1
TECHNICAL SPECIFICATIONS	2
General Specifications	2
Control and Logic	2
User Interface	2
Connectivity	2
Testing	2
CONTROLLER OVERVIEW	3
Overview of OCS	3
Power Wiring	3
DIGITAL & RELAY I/O SPECIFICATIONS	4
Digital DC Inputs: Models R & A	4
Model A: Digital DC Outputs, Sourcing	4
Model R: Digital DC Outputs, Sinking, Sourcing	4
Relay Outputs: Model R	4
ANALOG I/O SPECIFICATIONS	5
Analog Inputs, Models R & A	5
Analog Outputs, Models R & A	5
WIRING: INPUTS AND OUTPUTS	6
Analog Inputs Information	6
Digital Inputs	6
Relay Life	6
Inserting and Removing Connectors	6
Built-In I/O: Models R & A	6
J1 & J2 WIRING	7
J3 WIRING - Models A & R	8
COMMUNICATIONS	10
Serial Communication	10
Ethernet	10
CAN Communications	11
Discreet Wiring	11
DIMENSIONS & INSTALLATION	12
X7 Dimensions	12
Installation Procedure	12
SAFETY & MAINTENANCE	13
Warnings	13
FCC Compliance	13
Technical Support	13
Precautions	13

Part Numbers

Model R: Relay & Solid State Outputs	HE-X7R
Model A: Solid State Outputs	HE-X7A

User Manual and Add-Ons

Find the documents via the [Documentation Search](#).

Part #	Description
MAN1155	HE-X7 User Manual
HE-BAT009	3V Lithium Coin Battery
HE-XCK	Programming Cables
HE-FBD001	Ferrite core for filtering out electrical noise.
HE200MJ2TRM	Adapter, RJ45 (8P8C) male to 8-position terminal strip.

Battery Maintenance

The X7 has an advanced battery system that uses a lithium coin battery. The battery powers the real time clock when power is removed, and it is needed for register data retention. Manual **MAN1155** via the [Documentation Search](#) for more details on battery replacement.

TECHNICAL SPECIFICATIONS

General Specifications

Primary Pwr. Range	24VDC +/- 20%
Typical power Backlight 100%	190mA @ 24VDC
Power Backlight Off	123mA @ 24VDC
Inrush Current	30mA < 1ms
Real Time Clock	Battery backed; lithium coin cell CR2450
Battery Life	7-10 years
Clock Accuracy	+/- 90 Secs/Month
Relative Humidity	5 to 95% Non-condensing
Operating Temp.	-10°C to +60°C
Storage Temp.	-20°C to +70°C
Temperature Code	T5
Weight	20.8 oz/ 590g
Mounting Clips	4 composite type
Housing Material	Polycarbonate, UL rated
Altitude Limit	Up to 2000 meters
Environmental Ratings	1, 4X (indoor use only), 12, 12K & 13

Control and Logic

Control Language Support	Advanced ladder logic Full IEC 61131-3 languages
Logic Program Size	256kB
Non-Retentive Memory	128kB
Internal Storage Memory	16Mb
Total Program Memory	2.5Mb
Logic Scan Rate	0.4ms/kB
%I (Digital Inputs)	1024
%Q (Digital Outputs)	1024
%AI (Analog Inputs)	256
%AQ (Analog Outputs)	256
%M (Retentive Bits)	1024
%T (Temporary Bits)	1024
%R (Retentive Registers)	5000
%D (Display Bits)	250
%K (Key Bit)	4
%S (Status Bits)	13

User Interface

Display Type	7" 65k Color 300 cd/m ² (nits)
Resolution	800 X 480 pixels
Backlight	White LED
Backlight Lifetime	20,000 hrs to reach 50% brightness
Backlight Control	Software controlled (ON/OFF)
User-Programmable Screens/Pages	250
No. of Objects / Screens	100
Screen Memory	256kB
Keypad	Touch screen
Tactile Feedback	Optional Sound
Number of Keys	Max 30 per page + touch system and four function keys

Connectivity

Serial Ports	1 x RS232, 1 x RS485
485 Terminations	On-board, software controlled
Mini USB	Programming Only
CAN Hardware	CAN 2.0
CAN Port Connector	RJ45 (Red)
CAN Port Speeds Support	125kB, 250kB, 500kB, 1Mb/sec.
CAN Protocols	CsCAN
Ethernet	1 x 10Mbps/100Mbps
Removable Memory In	microSD (SDHC, SDXC IN FAT32 format, support for 32GB max. Application Updates, Datalogging, more)

Testing

Shock	IEC 60068-2-27
Vibration	IEC 60068-2-6
UL Environmental Ratings	Type 1, 4, 4X, 12, 12k & 13 (for indoor use only)
Certifications (UL/CE)	North America Europe

CONTROLLER OVERVIEW

Overview of OCS

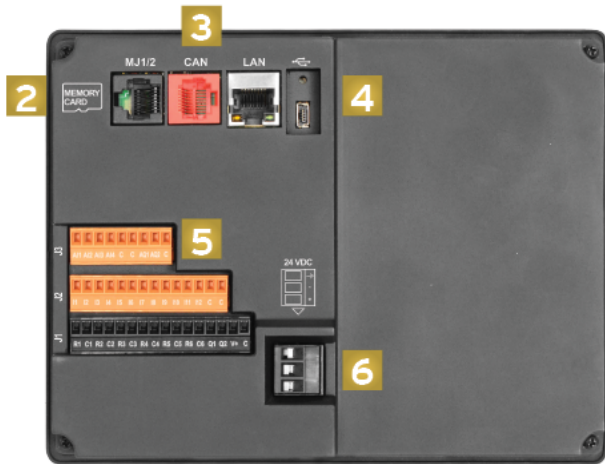

1. Touchscreen
2. Function Keys
3. RS232/RS485 Serial Port
4. CANPort (Via RJ45)
5. LAN Port
6. USB Mini-B Port
7. Analog I/O
8. DC Inputs
9. DC Outputs
10. DC Power

NOTE: See "Precautions" on page 13 about USB and grounding.

Power Wiring

NOTE: The Primary Power Range is 10VDC to 30VDC.

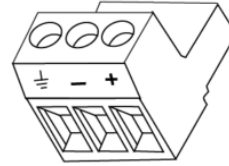

Primary Power Port Pins		
PIN	Signal	Description
1	Ground	Frame Ground
2	DC-	Input Power Supply Ground
3	DC+	Input Power Supply Voltage

DC Input / Frame

- Solid/Stranded Wire: 12-24 awg (2.5-0.2mm)
- Strip length: 0.28" (7mm)
- Torque, Terminal Hold-Down Screws: 4.5 – 7 in-lbs (0.50 – 0.78 N-m)
- DC- is internally connected to I/O V-, but is isolated from CAN V-. A Class 2 power supply must be used.

Power Up

1. **Optional:** Attach ferrite core with a minimum of two turns of the DC+ and DC- signals from the DC supply that is powering the controllers. See page 1.



2. Connect to earth ground.
3. Apply recommended power.

DIGITAL & RELAY I/O SPECIFICATIONS

Digital DC Inputs: Models R & A

Inputs per Module	12 including 4 configurable HSC inputs	
Commons per Module	1	
Input Voltage Range	12VDC / 24VDC	
Absolute Max. Voltage	30VDC Max.	
Input Impedance	10kΩ	
Input Current	Positive Logic	Negative Logic
Upper Threshold	0.8mA	-1.6mA
Lower Threshold	0.3mA	-2.1mA
Max. Upper Threshold	8VDC	
Min. Lower Threshold	3VDC	
OFF to ON Response	0.1ms	
ON to OFF Response	0.1ms	
Number of Counters	4	
Maximum Frequency	500kHz	
Accumulator Size	32-bits each	
Modes Supported	Totalizer, quadrature, pulse measurement, frequency measurement, set-point controlled outputs	

Model R: Digital DC Outputs, Sinking, Sourcing

Outputs per Module	2 (PWM or HSC)	
Commons per Module	1	
Type	Sinking	
Absolute Max. Voltage	28VDC	
Output Protection	Short Circuit	
Max. Output per Point: Sinking	0.5A	
Max. Output per Point: Sourcing	2.4mA @ 24V	
Max. Voltage Drop at Rated Current	0.25VDC	
Max Outrush	650mA	
	Min	Max
OFF to ON Time (typical)	2.2μs	2.2μs + Scan Time
ON to OFF Time (typical)	13μs	13μs + Scan Time
PWM Out	65kHz	
Rise Time	2.4μs (typical @ 24V)	
Fall Time	7.5μs (typical @ 24V)	

Model A: Digital DC Outputs, Sourcing

Outputs per Module	12 Including 2 Configurable PWM Outputs	
Commons per Module	2	
Type	Sourcing	
Absolute Max. Voltage	28VDC	
Output Protection	Short Circuit, Thermal, Undervoltage	
Max. Voltage Drop at Rated Current	0.25VDC	
Max Output per Point: Sourcing	0.5A @ 24VDC	
	Min	Max
OFF to ON Time (typical)	300ns	500ns + Scan Time
ON to OFF Time (typical)	300ns	475 = Scan Time
PWM Out	65kHz	
Rise Time	150ns Max	
Fall Time	150ns Max	

Relay Outputs: Model R

Outputs per Module	6 Relay
Relay Contact Type	Floating
Max. Output Current & Voltage per Relay	3A @ 60VAC, resistive 3A @ 30VDC, resistive
Max. Total Output Current	5A continuous
Max. Switched Power	150W
Contact Isolation to Ground	1000VAC
Max. Voltage Drop at Rated Current	0.5V
Expected Life (see derating chart)	No Load: 5,000,000 Rated Load: 100,000
Max. Switching Rate	300 CPM at no load 20 CPM at rated load
Type	Mechanical Contact
Response Time	One update per ladder scan plus 10 ms

ANALOG I/O SPECIFICATIONS

Analog Inputs, Models R & A

Number of Channels	4
Input Ranges	0-20mA; 4-20mA; RTD100
RTD Temperature Range	-50° to 200°C (-58° to 392°F) PT100 DIN
Nominal Resolution	12 Bits
Resolution	0.5°C
Safe Input Voltage Range	-0.5V to 12V, protection up to 24V
Input Impedance (clamped @ -0.5VDC to 12VDC)	Current Mode: 100Ω
%AI Full Scale	20mA: 32,000 full scale RTD: 20 Counts/°C
Max. Over Current	25mA
Max Error at 25°C (excluding Zero)	< 1.5% of full scale
Filtering	160 Hz Hash (noise) Filter, 1-128 Scan Digital Running Average Filter

Analog Outputs, Models R & A

Number of Channels	2
Output Ranges	4-20mA
Nominal Resolution	12 Bits
Update Rate	Once per PLC scan
Max. Error at 25°C (Excluding Zero)	< 1.5% of full scale
Maximum 20mA Load	500Ω
% AQ Full Scale	32,000
Protection	Protect against miswire up to 24VDC auto-recover

WIRING: INPUTS AND OUTPUTS

Analog Inputs Information

Raw input values for channels 1-4 are found in the registers as Integer- type data with a range from 0 – 32000.

Analog inputs may be filtered digitally with the Filter Constant found in the Cscape Hardware Configuration for Analog Inputs. Valid filter values are 0-7 and act according to the following chart:

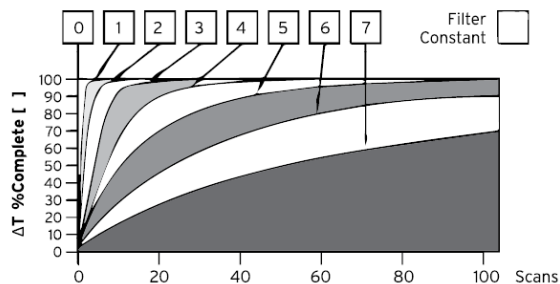

Data Values	
Input Mode:	Data Format, 12-bit INT:
0-20mA, 4-20mA	0-32000
RTD	20 Counts/ °C

Digital Inputs

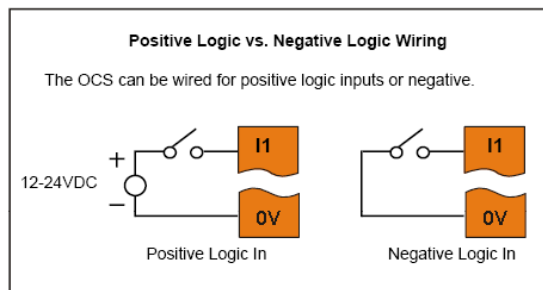

Digital inputs may be wired in either a Positive Logic or Negative Logic fashion as shown. The setting in the Cscape Hardware Configuration for the Digital Inputs must match the wiring used in order for the correct input states to be registered.

Relay Life

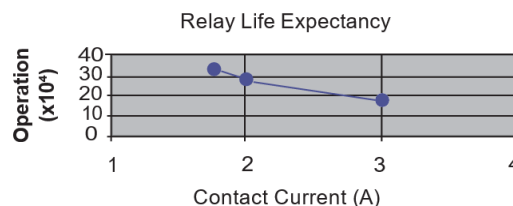

WARNING: Exposure to some chemicals may degrade the sealing properties of materials used in the Tyco relay PCJ.
Cover/Case & Base: Mitsubishi engineering Plastics Corp. 5010GN6-30 or 5010GN6-30 M8 (PBT)
Sealing Material: Kishimoto 4616-50K (1 part epoxy resin)

Inserting and Removing Connectors

To Insert: Using a small screwdriver, firmly press on connector on one end and then the other until connector clicks into place. Ensure connector is firmly seated.

To Remove: Use a small screwdriver on each side of connector to gently pry up the connector.

Built-In I/O: Models R & A

Fixed Address	I/O Function	Model R	Model A
%I	Digital Inputs	1-12	1-12
	Reserved	13-32	13-32
%Q	Digital Outputs	1-2	1-12
	Relay Outputs	3-8	--
	Reserved	9-24	13-24
%AI	Analog Inputs	1-4	1-4
	Reserved	5-12	5-12
%AQ	Analog Outputs	1-2	1-2
	Reserved	3-16	3-16

J1 & J2 WIRING

J1 Wiring: Model A - Digital Out

POSITION/PIN	DIGITAL MODEL	DIGITAL MODEL
1	Q1 (%Q1)	Dig. Out 1 (PWM)
2	Q2 (%Q2)	Dig. Out 2 (PWM)
3	Q3 (%Q3)	Dig. Out. 3
4	Q4 (%Q4)	Dig Out. 4
5	V+	External V+
6	C	Common
7	Q5 (%Q5)	Dig Out. 5
8	Q6 (%Q6)	Dig Out. 6
9	Q7 (%Q7)	Dig Out. 7
10	Q8 (%Q8)	Dig Out. 8
11	Q9 (%Q9)	Dig Out. 9
12	Q10 (%Q10)	Dig Out. 10
13	Q11 (%Q11)	Dig Out.11
14	Q12 (%Q12)	Dig Out. 12
15	V+	External V 2 +
16	C	Common

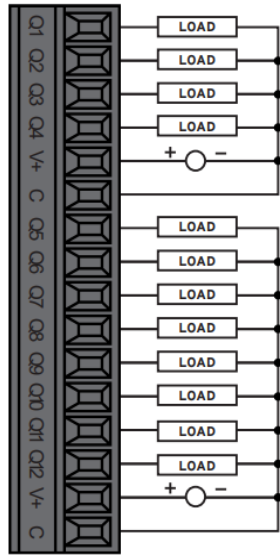

NOTE: Internal 10kΩ resistors between: V+ and Q1; V+ and Q2

Sinking & Sourcing Wiring on Model R

Model R: Sourcing Outputs [2.4mA @ 24V]

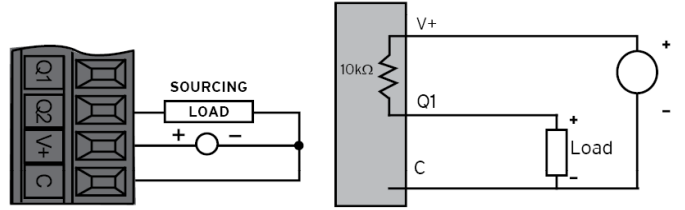

Model R: Sinking Outputs [Outputs can sink 500mA]

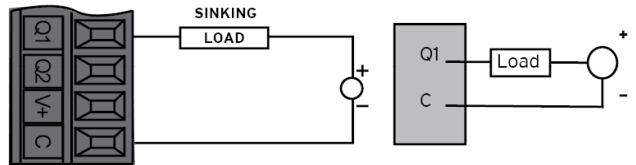

J1 Wiring: Model R - Relay / Digital Out

POSITION/PIN	DIGITAL MODEL	DIGITAL MODEL
1	R1 (%Q3)	Relay 1 N.O.
2	C1 (%Q3)	Relay 1 C
3	R2 (%Q4)	Relay 2 N.O.
4	C2 (%Q4)	Relay 2 C
5	R3 (%Q5)	Relay 3 N.O.
6	C3 (%Q5)	Relay 3 C
7	R4 (%Q6)	Relay 4 N.O.
8	C4 (%Q6)	Relay 4 C
9	R5 (%Q7)	Relay 5 N.O.
10	C5 (%Q7)	Relay 5 C
11	R6 (%Q8)	Relay 6 N.O.
12	C6 (%Q8)	Relay 6 C
13	Q1 (%Q1)	Dig. OUT 1
14	Q2 (%Q2)	Dig. OUT 2
15	V+	External V+
16	C	Common

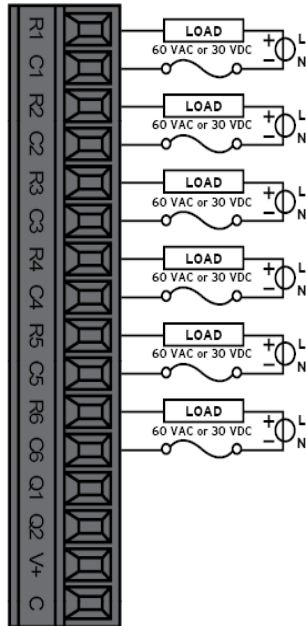

J2 Wiring: Models R & A - Digital Input

POSITION/PIN	DIGITAL MODEL	DIGITAL MODEL
1	I1 (%I1)	Dig. IN 1
2	I2 (%I2)	Dig. IN 2
3	I3 (%I3)	Dig. IN 3
4	I4 (%I4)	Dig. IN 4
5	I5 (%I5)	Dig. IN 5
6	I6 (%I6)	Dig. IN 6
7	I7 (%I7)	Dig. IN 7
8	I8 (%I8)	Dig. IN 8
9	I9 (%I9)	Dig. IN 9 (HSC)
10	I10 (%I10)	Dig. IN 10 (HSC)
11	I11 (%I11)	Dig. IN 11 (HSC)
12	I12 (%I12)	Dig. IN 12 (HSC)
13	C	Common
14	C	Common

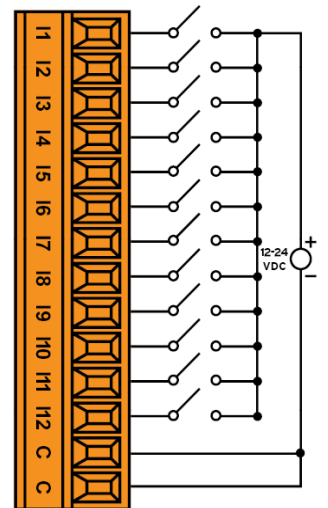

J3 WIRING - Models A & R

4 X 4-20mA Input / 4-20mA Output

PIN	Wire
1	AI1 (%AI1)
2	R1+ (%AI1)
3	AI2 (%AI2)
4	R2+ (%AI2)
5	AI3 (AI3/%AQ1)
6	R3+ or AQ1 (AI3/%AQ1)
7	AI4 (AI4/%AQ2)
8	R4+ or AQ2 (AI4/%AQ2)
9	C

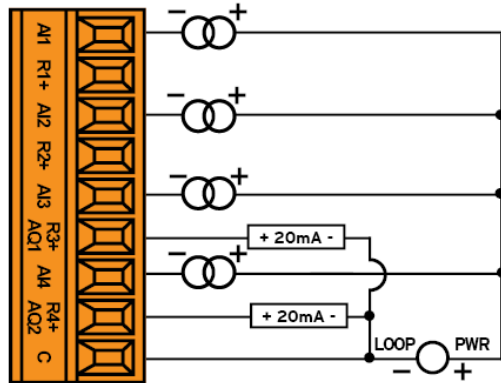

If AQ1 is used, RTD3 is unavailable.
If AQ2 is used, RTD4 is unavailable.

RTD: 2 x 3 - Wire RTD & 2 x 4-20mA Output

PIN	Wire	Connection
1	AI1 (%AI1)	RTD Sense
2	R1+ (%AI1)	RTD Excitation
3	AI2 (%AI2)	RTD Sense
4	R2+ (%AI2)	RTD Excitation
5	AI3 (AI3/%AQ1)	No Connection
6	R3+ or AQ1 (AI3/%AQ1)	mA Output
7	AI4 (AI4/%AQ2)	No Connection
8	R4+ or AQ2 (AI4/%AQ2)	mA Output
9	C	Common

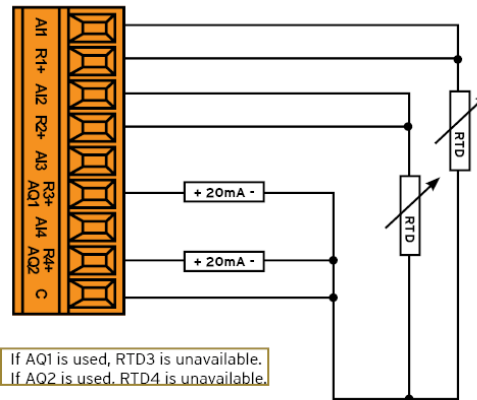

If AQ1 is used, RTD3 is unavailable.
If AQ2 is used, RTD4 is unavailable.

Universal Wiring Schematic

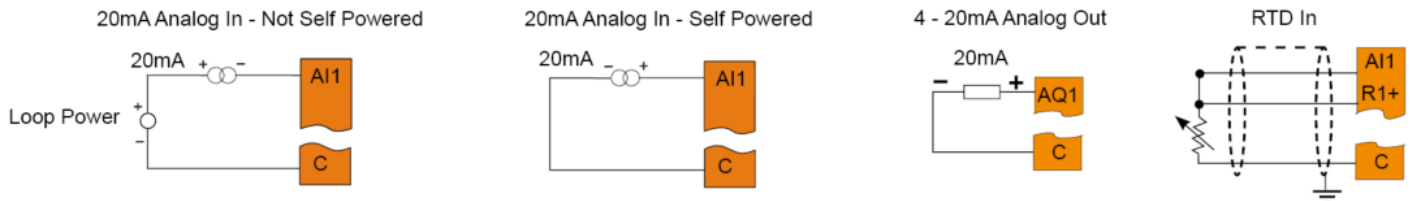

RTD: 4 x 2 - Wire RTD Connection

PIN	Wire	Connection
1	AI1 (%AI1)	RTD Sense
2	R1+ (%AI1)	RTD Excitation
3	AI2 (%AI2)	RTD Sense
4	R2+ (%AI1)	RTD Excitation
5	AI3 (AI3/%AQ1)	RTD Sense
6	R3+ or AQ1 (AI3/%AQ1)	RTD Excitation
7	AI4 (AI4/%AQ2)	RTD Sense
8	R4+ or AQ2 (AI4/%AQ2)	RTD Excitation
9	C	Common

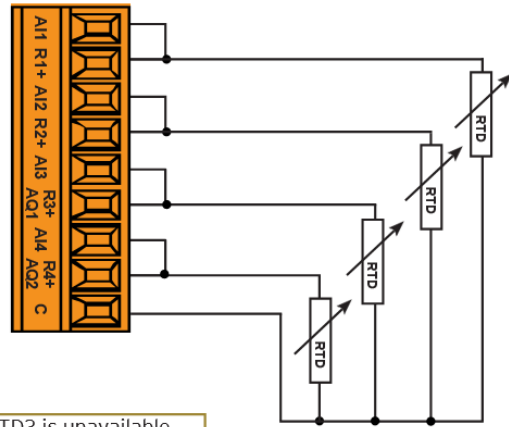

If AQ1 is used, RTD3 is unavailable.
If AQ2 is used, RTD4 is unavailable.

RTD: 4 x 3 - Wiring RTD Connection

PIN	Wire	Connection
1	AI1 (%AI1)	RTD Sense
2	R1+ (%AI1)	RTD Excitation
3	AI2 (%AI2)	RTD Sense
4	R2+ (%AI1)	RTD Excitation
5	AI3 (AI3/%AQ1)	RTD Sense
6	R3+ or AQ1 (AI3/%AQ1)	RTD Excitation
7	AI4 (AI4/%AQ2)	RTD Sense
8	R4+ or AQ2 (AI4/%AQ2)	RTD Excitation
9	C	Common

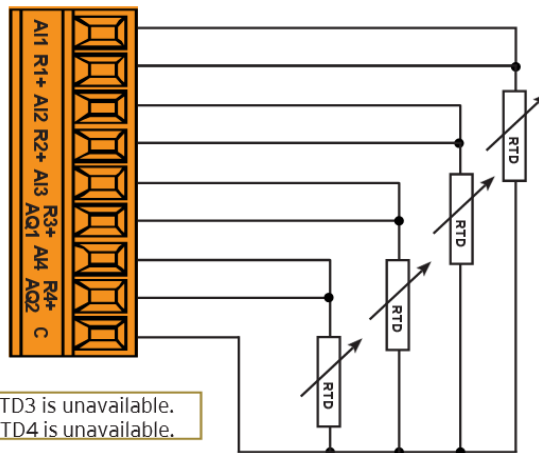

If AQ1 is used, RTD3 is unavailable.
If AQ2 is used, RTD4 is unavailable.

Universal Wiring Schematic

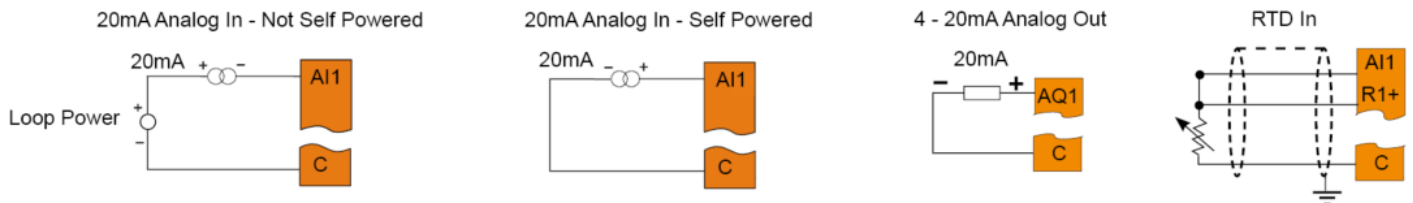

COMMUNICATIONS

Serial Communication

MJ1/2 Serial Ports

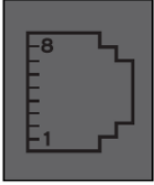

2 Serial Ports on 1 Module Jack (8posn)

MJ1: RS-232 w/Full Handshaking

MJ2: RS-485 Half-Duplex - RS-485 termination and biasing via System Menu or System Register

MJ1 & MJ2 PINS		
PIN	SIGNAL	DIRECTION
8	TXD	OUT
7	RXD	IN
6	0V	COMMON
5	+5V @ 60mA	OUT
4	RTS	OUT
3	CTS	IN
2	RX- / TX-	IN / OUT
1	RX+ / TX+	IN / OUT

NOTE: Attach optional Ferrite Core (HE-FBD001) with a minimum of two turns of serial cable.

Ethernet

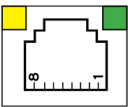

Green LED indicates link - when illuminated, data communication is available.

Yellow LED indicates activity - when flashing, data is in transmission.

CAN Communications

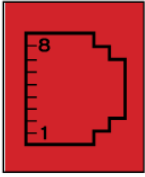

Modular jack (8 posn RJ45)

MJ1 & MJ2 PINS		
PIN	SIGNAL	DIRECTION
8	TXD	OUT
7	RXD	IN
6	0V	COMMON
5	+5V @ 60mA	OUT
4	RTS	OUT
3	CTS	IN
2	RX- / TX-	IN / OUT
1	RX+ / TX+	IN / OUT

The CAN port is provided via the single 8-position modular jack labeled “CAN”. It may be used to communicate with other OCS products using Horner’s CsCAN protocol. Additionally, remote expansion I/O such as SmartRail, SmartBlock, and SmartStix may be implemented using the CsCAN protocol.

Termination for the CAN port may be enabled from the System Menu or System Register. This should only occur if the X4 is at either end of the CAN network. Only the two devices on either end of the CAN network should be terminated.

Discreet Wiring

For CAN or serial connections the [HE200MJ2TRM](#) accessory will provide a modular connector to wiring block adapter for installations that require discreet wiring.



DIMENSIONS & INSTALLATION

X7 Dimensions

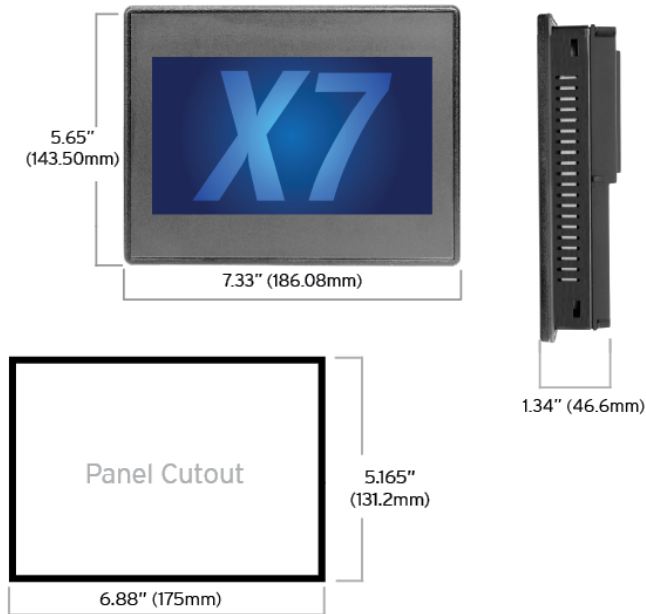

Panel Tolerance +/- 0.5mm

Installation Procedure

- This equipment is panel mounted and is meant to be installed in an enclosure suitable for the environment, such that the back of the equipment is only accessible with the use of a tool.
- Requires a Class 2 Power Source.
- This equipment is suitable for use in Class I, Division 2, Groups A, B, C and D; Class II, Division 2 Groups F and G; and Class III Hazardous Locations or Non-Hazardous Locations only.
- The X7 utilizes a clip installation method to ensure a robust and watertight seal to the enclosure. Follow the steps below for the proper installation and operation of the unit.

Please following the steps below for the proper installation and operation of the unit.

1. Carefully locate an appropriate place to mount the X7. Be sure to leave enough room at the top of the unit for insertion and removal of the microSD™ card.
2. Carefully cut the host panel per the diagram, creating a 131.2mm x 175mm with a cutout tolerance of +/-0.5mm opening into which the X7 is to be installed. If the opening is too large, water may leak into the enclosure, potentially damaging the unit. If the opening is too small, the OCS may not fit through the hole without damage.
3. Remove any burrs/sharp edges and ensure the panel is not warped in the cutting process.
4. Install and tighten the four mounting clips (provided in the box) until the gasket forms a tight seal. For standard composite mounting clips (included with product). **NOTE: Torque rating is 2-3 in-lbs (0.23-0.34 Nm). For optional metal mounting clips, use a torque rating of 4-8 in-lbs (0.45-0.90 Nm).**
5. Connect communications cables to the serial port, USB ports, and CAN port as required.

SAFETY & MAINTENANCE

Warnings

1. To avoid the risk of electric shock or burns, always connect the safety (or earth) ground before making any other connections.
2. To reduce the risk of fire, electrical shock, or physical injury, it is strongly recommended to fuse the voltage measurement inputs. Be sure to locate fuses as close to the source as possible.
3. Replace fuse with the same type and rating to provide protection against risk of fire and shock hazards.
4. In the event of repeated failure, do NOT replace the fuse again as repeated failure indicates a defective condition that will NOT clear by replacing the fuse.
5. Only qualified electrical personnel familiar with the construction and operation of this equipment and the hazards involved should install, adjust, operate, or service this equipment.
6. Read and understand this manual and other applicable manuals in their entirety before proceeding. Failure to observe this precaution could result in severe bodily injury or loss of life.
7. **WARNING** - Battery may explode if mistreated. Do not recharge, disassemble, or dispose of in fire.
8. **WARNING - EXPLOSION HAZARD** - Batteries must only be changed in an area known to be non-hazardous.
9. **WARNING** - Do not disconnect while circuit is live unless are is know to be non-hazardous.

FCC Compliance

This device complies with Part 15 of the FCC Rules. Operation is subject to the following

two conditions:

1. This device may not cause harmful interference.
2. This device must accept any interference received, including interference that may cause undesired operation.

Technical Support

North America

1 (317) 916-4274

(877) 665-5666

www.hornerautomation.com

techsppt@heapg.com

Europe

+353 (21) 4321-266

www.hornerautomation.eu

technical.support@horner-apg.com

Precautions

All applicable codes and standards need to be followed in the installation of this product. Adhere to the following safety precautions whenever any type of connection is made to the module:

1. Connect the safety (earth) ground on the power connector first before making any
2. other connections.
3. When connecting to the electric circuits or pulse-initiating equipment, open their
4. related breakers.
5. Do NOT make connection to live power lines.
6. Make connections to the module first; then connect to the circuit to be monitored.
7. Route power wires in a safe manner in accordance with good practice and local codes.
8. Wear proper personal protective equipment including safety glasses and insulated gloves when making connections to power circuits.
9. Ensure hands, shoes, and floor are dry before making any connection to a power line.
10. Make sure the unit is turned OFF before making connection to terminals.
11. Make sure all circuits are de-energized before making connections.
12. Before each use, inspect all cables for breaks or cracks in the insulation. Replace
13. immediately if defective.
14. Use copper conductors in Field Wiring only, 60/75°C.
15. Use caution when connecting controllers to PCs via serial or USB. PCs, especially laptops, may use "floating power supplies" that are ungrounded. This could cause a damaging voltage potential between the laptop and controller. Ensure the controller and laptop are grounded for maximum protection. Consider using a USB isolator due to voltage potential differences as a preventative measure.