



HE-WIFIUSB DATASHEET

The Horner Wi-Fi adapter, or HE-WIFIUSB, provides both client and access point support to OCS units that support USB Host connections with the XL4e, X5, EXL6e, EXLW, XL7e, EXL10e, XL+ and RCC2414. As an access point, the HE-WIFIUSB can be used to connect laptops, phones, and tablets to the OCS for programming, WebMI access and FTP file transfers. Using client mode, the OCS can connect to an established Wi-Fi network and support any of the Ethernet protocols supported by the OCS, including FTP and Modbus. See the User Manual, MAN1234, for more details.

1. Technical Specifications

1.1 Power Specifications

Power Consumption	<500mA @ 5 volts
Additional Power Required to Controller	80mA @ 24V; 180mA @ 10V

1.2 Environmental and Material Specs

Material	Polyamide over-molding
Mounting Type	Panel / Stand Alone (Requires Fittings)
Cable Length	1.9m (6.2')
Panel Cutout Size	3/4" NPT or 30.1mm
Panel Seal	IP65 / NEMA 4X
Rear Seal	IP65 / NEMA 4X
Operating Temperature	-20°C to 70°C
Relative Humidity	10% to 95% non-condensing
Standards	IEEE 802.11b/g/n
Approvals	US (FCC), Canada (IC), Europe (CE) 2014/53/ EU Radio Equipment Directive (RED)

1.3 Wireless Specifications

Max Power Output	15 dBm (including antenna)
Channel Bandwidth	20 MHz
Wi-Fi Channels	2.4 GHz, Channels 1-11 + 12-13 depending on location settings
Range	Up to 100m (328')
Maximum Sensitivity	-97 dBm
Standards	IEEE 802.11b/g/n
Data Rates	802.11b 1, 2, 5.5 and 11 Mbps 802.11g 6, 9, 12, 18, 24, 36, 48 and 54 Mbps 802.11n MCS0-MCS7 (max 72.2Mbps)
Encryption	WPA2
Antenna	Built-in with LTE filter

1.4 OCS Specifications

Access Point Max Clients	8
OCS Interface	USB 2.0 (Requires OCS with USB 2.0 HOST Support)
Compatible Products	HE-XC1Ex, HE-X5, HE-EXL1Ex, HE-EXLWEx, HE-XW1Ex, HE-EXV1Ex, HE-XP7Ex, HE-RCC2414

2. Overview

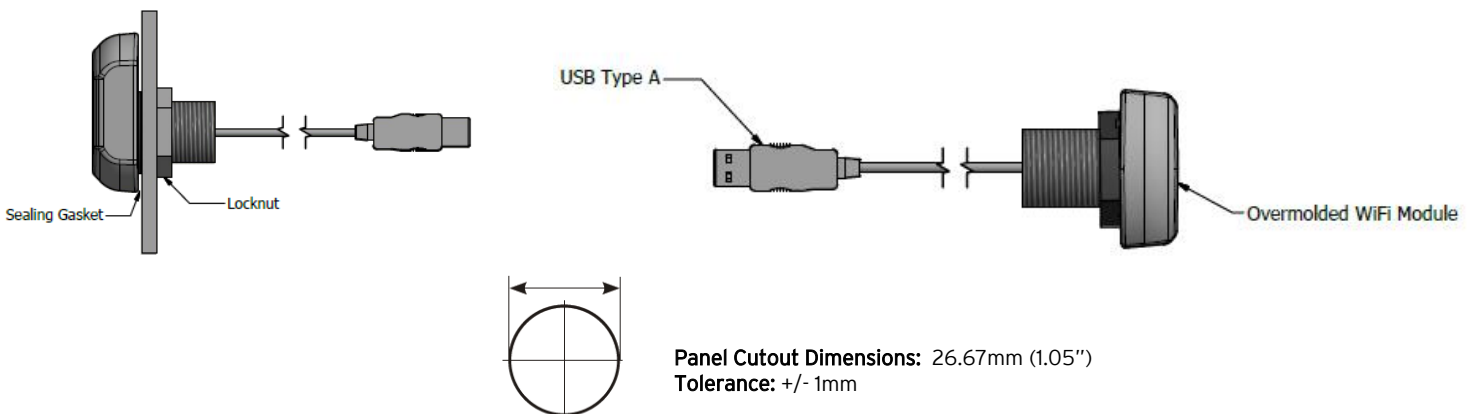

3. Dimensions

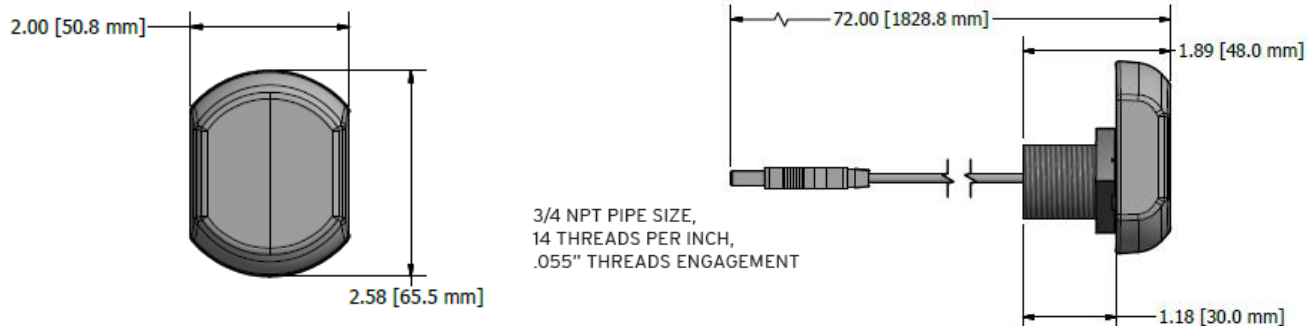

4. Installation Instructions

NOTE: HE-WIFIUSB unit is designed to be mounted outside the panel box. Mounting inside metal cabinets will significantly reduce the range of this product.

1. Ensure your controller is updated to the most recent version of firmware dependent on its version.
2. Turn off the controller.
3. Drill a hole in the panel box housing according to diagram.
4. Place the sealing gasket then place the HE-WIFIUSB unit in the panel cutout. Place the locknut on the threads and tighten to hand tight. **NOTE:** Using a tool on the plastic threads could damage the unit.
5. Plug the HE-WIFIUSB into the USB port on controller.
6. Turn on the controller. The HE-WIFIUSB unit will now be active.

5. Safety & Warnings

5.1 Warnings

1. Only qualified electrical personnel familiar with the construction and operation of this equipment and the hazards involved should install, adjust, operate, or service this equipment.
2. Read and understand this manual and other applicable manuals in their entirety before proceeding.
3. Failure to observe this precaution could result in severe bodily injury or loss of life.
4. This module uses industry standard security and data integrity systems; however, care must be taken with any wireless system. Reviews on security and data integrity must be performed and appropriate mitigations must be put in place. Use of this or any wireless module for critical data or operation is not recommended.

5.2 FCC Compliance

This device complies with Part 15 of the FCC Rules. Operation is subject to the following two conditions:

1. This device may not cause harmful interference
2. This device must accept any interference received, including interference that may cause undesired operation.

5.3 Precautions

All applicable codes and standards need to be followed in the installation of this product. Adhere to the following safety precautions whenever any type of connection is made to the module:

1. Connect the safety (earth) ground on the power connector first before making any other connections.
2. When connecting to the electric circuits or pulse-initiating equipment, open their related breakers.

3. Do NOT make connection to live power lines.
4. Make connections to the module first; then connect to the circuit to be monitored.
5. Route power wires in a safe manner in accordance with good practice and local codes.
6. Wear proper personal protective equipment including safety glasses and insulated gloves when making connections to power circuits.
7. Ensure hands, shoes, and floor are dry before making any connection to a power line.
8. Make sure the unit is turned OFF before making connection to terminals.
9. Make sure all circuits are de-energized before making connections.
10. Before each use, inspect all cables for breaks or cracks in the insulation. Replace immediately if defective.
11. Use copper conductors in Field Wiring only, 60/75°C.

6. Technical Support

For assistance and manual updates, contact Technical Support at the following locations:

North America

(317) 916-4274
www.hornerautomation.com
 techsppt@heapg.com

Europe

(+) 353-21-4321-266
www.hornerautomation.eu
 technical.support@horner.apg.com