



SmartStix™ Analog I/O Modules

HE559MIX577/ HE559MIX977

4 Input Channels, 2 Output Channels / 8 Input Channels, 4 Sourcing Output Channels
 $\pm 5V$ / $\pm 10V$ / 4-20mA / $\pm 20mA$
 CsCAN

1 SPECIFICATIONS

| ANALOG IN | | | | |
|---------------------------------------|--|------------------------------------|--|---|
| Input Ranges | $\pm 5V$, $\pm 10V$ DC 4-20mA, $\pm 20mA$ DC | Isolation | | 1000V DC IEC61010-1 300V RMS |
| Resolution | 14 bits | Isolation Method | | Magnetic |
| Input Impedance | V: 1 Megohm mA: 150 Ohms | Maximum Continuous Overload | | $\pm 10V$: 150VAC $\pm 20mA$: $\pm 30mA$, Clamped at $\pm 6V$ |
| Filter Modes | Running Average or Adaptive | Programmable Filter Time Constants | | 0.01 to 1.28 Seconds |
| ANALOG OUT | | | | |
| Output Ranges | ± 5 , $\pm 10V$ DC 4-20mA, $\pm 20mA$ DC | Isolation | | 1000V DC IEC61010-1 300V RMS |
| Resolution | 14 bits | Isolation Method | | Magnetic |
| Load Resistance | V: 600 Min mA: 500 Max | Output Clamp | | $\pm 12V$, 600Wpk |
| | | Output Characteristic | | Sourcing |
| GENERAL | | | | |
| Required Power (Steady State) | 3.6W (150ma @ 24VDC) | Operating Temperature | | 0° to 55° C |
| Required Power (Inrush) | 8A @ 24VDC for 1ms | Operating and Storage Humidity | | 5 to 95% Non-condensing |
| Storage Temperature | -25° to 70° C | Altitude for use | | Up to 2,000m |
| Atmosphere | Free from corrosive gases and excessive dust | Pollution degree | | 2 or lower |
| | | Cooling method | | Self-cooling |
| Vibration | | | | |
| Occasional Vibration | | | | |
| Frequency | Acceleration | Amplitude | Sweep Count | |
| $10 \leq f < 57$ Hz | - | 0.075 mm | 10 times in each direction for X,Y,Z | |
| $57 \leq f \leq 150$ Hz | 9.8 m/s ² {1G} | - | | |
| Continuous Vibration | | | | |
| Frequency | Acceleration | Amplitude | Sweep Count | |
| $10 \leq f < 57$ Hz | - | 0.035 mm | 10 times in each direction for X,Y,Z | |
| $57 \leq f \leq 150$ Hz | 4.9 m/s ² {0.5G} | - | | |
| Shocks | | | | |
| Maximum shock acceleration | 147 m/s ² {15G} | | | |
| Duration Time | 11 ms. | | | |
| Pulse Wave | Half sine wave pulse (3 times in each of X, Y, Z directions) | | | |
| Noise Immunity | | | | |
| Square wave impulse noise | AC: $\pm 1,500VDC$ DC: $\pm 900VDC$ | | | |
| Electrostatic Discharge | Voltage: 4kV (contact discharge) | | | |
| Radiated electromagnetic field | 27 – 500MHz, 10V/m | | | |
| Fast Transient Burst Noise | Severity level | All power modules | Digital I/Os (Ue $\geq 24V$) | Digital I/Os (Ue < 24 V) Analog I/Os Communication I/Os |
| | Voltage | 2 kV | 1 kV | 0.25 kV |
| | | MIX577 | MIX977 | |
| ANALOG IN | | | | |
| Number of input points | 4 | | 8 | |
| Conversion Time | 5mS for all Channels | | 10ms for all Channels | |
| Accuracy, 25°C | 0.3% | | 0.1% | |
| Register Value for Nominal Full Scale | 32000 | | ± 32000 | |
| ANALOG OUT | | | | |
| Number of output points | 2 | | 4 | |
| Accuracy, 25°C | 0.3% | | 0.1% | |
| Register Value for Nominal Full Scale | 32000 | | ± 32000 | |
| Max Output current, mA mode | - | | 3 channels driving 20mA max output loads | |
| GENERAL | | | | |
| Weight | 8.40 oz. (238 g) | | 9 oz. (256g) | |

2 DIMENSIONS

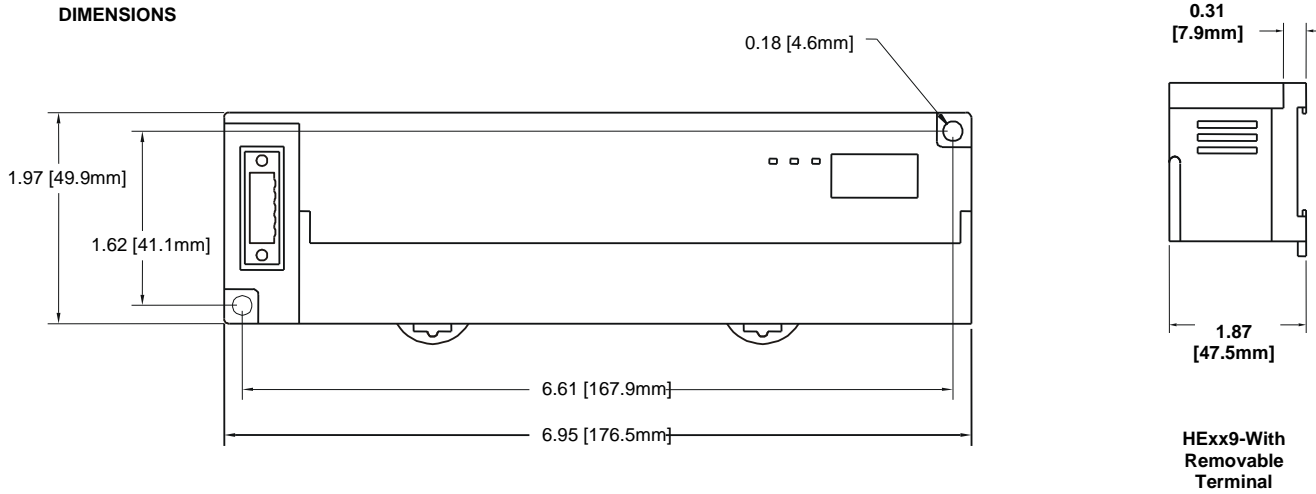

3 WIRING

a. MIX577

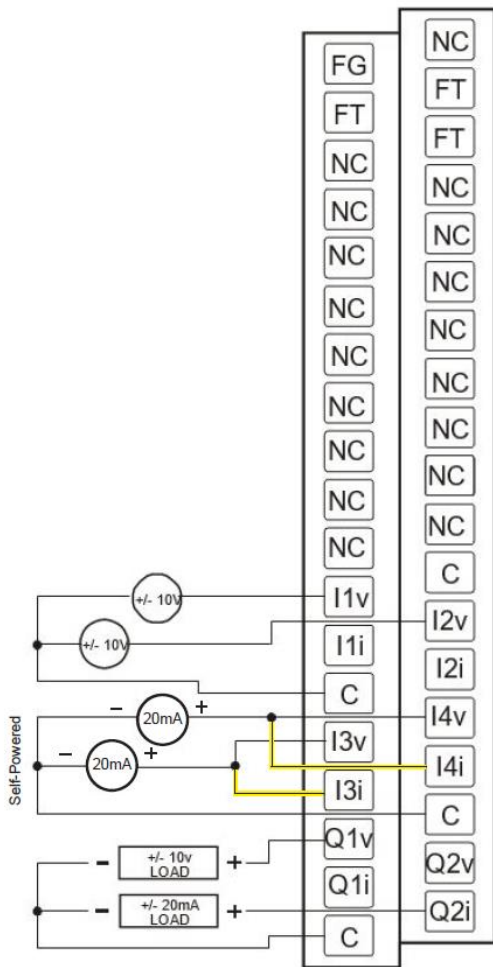

| MIX577 | |
|--------|-----|
| 2 | FG |
| 4 | FT |
| 6 | NC |
| 8 | NC |
| 10 | NC |
| 12 | NC |
| 14 | NC |
| 16 | NC |
| 18 | NC |
| 20 | NC |
| 22 | NC |
| 24 | I1v |
| 26 | I1i |
| 28 | C |
| 30 | I3v |
| 32 | I3i |
| 34 | Q1v |
| 36 | Q1i |
| 38 | C |

| MIX577 | |
|--------|-----|
| 1 | NC |
| 3 | FT |
| 5 | FT |
| 7 | NC |
| 9 | NC |
| 11 | NC |
| 13 | NC |
| 15 | NC |
| 17 | NC |
| 19 | NC |
| 21 | NC |
| 23 | C |
| 25 | I2v |
| 27 | I2i |
| 29 | I4v |
| 31 | I4i |
| 33 | C |
| 35 | Q2v |
| 37 | Q2i |

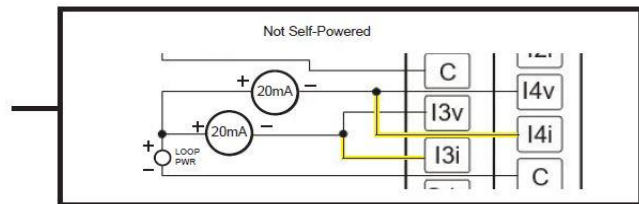

C terminals are connected together internally but isolated from bus and power circuits.

b. MIX977

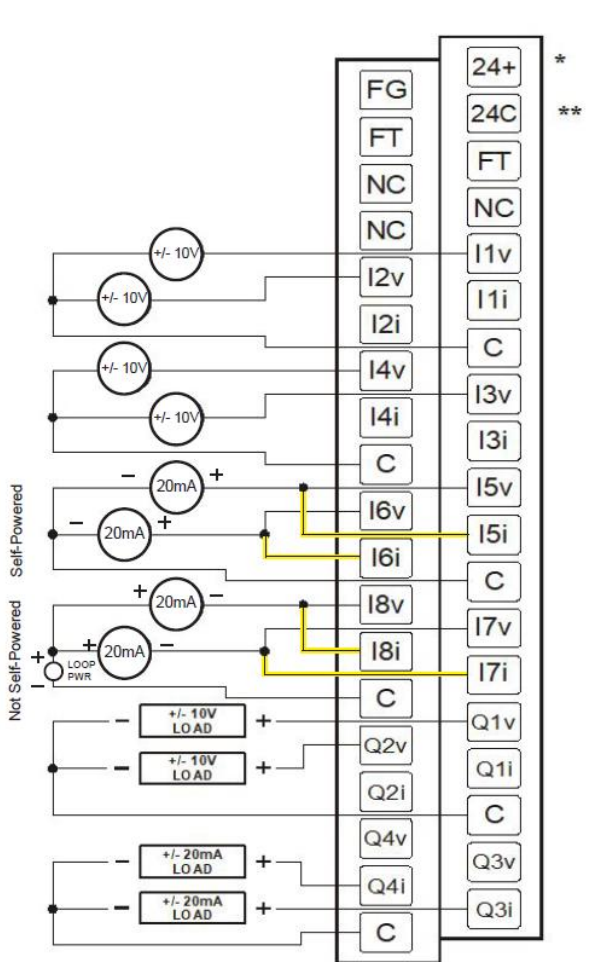

| MIX977 | | MIX977 | |
|--------|-----|--------|--------|
| 2 | FG | 1 | 24+ * |
| 4 | FT | 3 | 24C ** |
| 6 | NC | 5 | FT |
| 8 | NC | 7 | NC |
| 10 | I2v | 9 | I1v |
| 12 | I2i | 11 | I1i |
| 14 | I4v | 13 | C |
| 16 | I4i | 15 | I3v |
| 18 | C | 17 | I3i |
| 20 | I6v | 19 | I5v |
| 22 | I6i | 21 | I5i |
| 24 | I8v | 23 | C |
| 26 | I8i | 25 | I7v |
| 28 | C | 27 | I7i |
| 30 | Q2v | 29 | Q1v |
| 32 | Q2i | 31 | Q1i |
| 34 | Q4v | 33 | C |
| 36 | Q4i | 35 | Q3v |
| 38 | C | 37 | Q3i |

FT: Factory Test, Do **Not** Connect
 FG: Frame Ground

C terminals are connected together internally but isolated from bus and power circuits.

* and ** For CsCAN and DeviceNet versions, module power is usually derived from the CAN connector. In that case, +24VDC and 24C are not connected.

4 INTERNAL WIRING

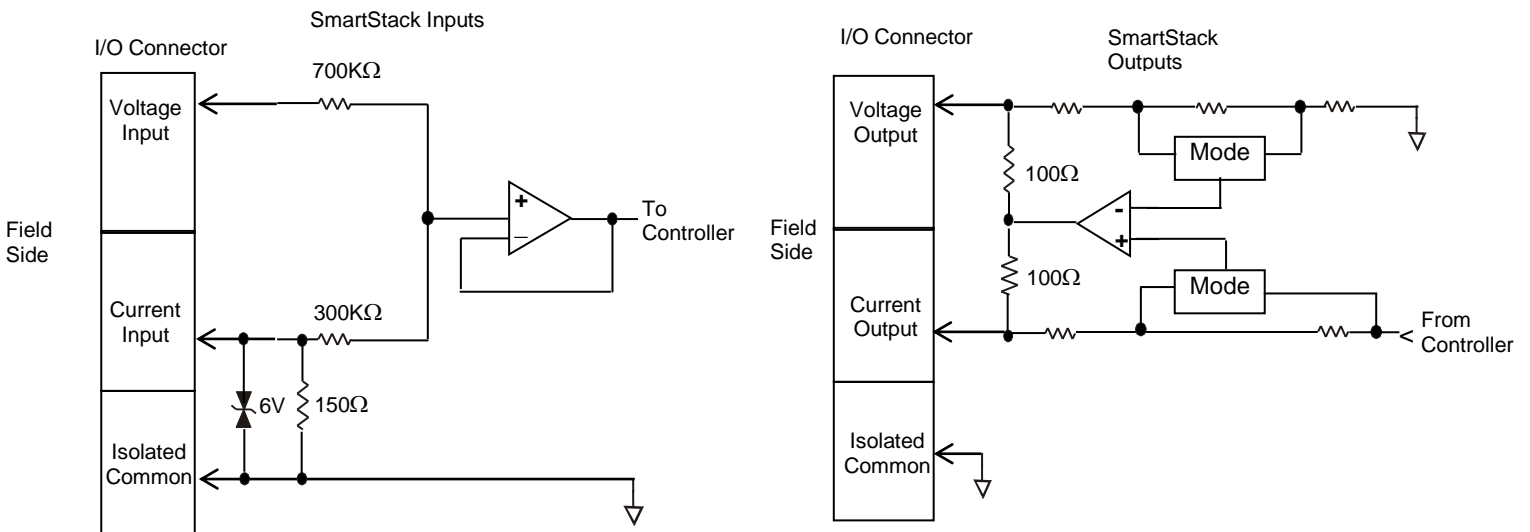

5 CHANNEL MODE, PROGRAMMABLE FILTER, AND OUTPUT DEFAULT CONFIGURATION

The network supplies configuration information to the unit in the Consumed Directed Digital Data Words sent to the unit. In the first word, the low 12 bits, 1 through 12, are channel mode bits. A low mode bit selects ±10V and a high mode bit selects ±20mA. The next three bits, 13 through 15, are input digital filter time constant codes and the high bit, 16, is an adaptive filter enable bit. In the second word, the low 12 bits are channel scale bits. A low scale bit selects ±10V or ±20mA for the corresponding channel. A high scale bit selects ±5V or 4-20mA. The upper four bits are unused.

| Bit | MIX577 Channel | MIX977 Channel |
|-----|----------------|----------------|
| 1 | AI1 | AI1 |
| 2 | AI2 | AI2 |
| 3 | AI3 | AI3 |
| 4 | AI4 | AI4 |
| 5 | Not used | AI5 |
| 6 | Not used | AI6 |
| 7 | Not used | AI7 |
| 8 | Not used | AI8 |
| 9 | AQ1 | AQ1 |
| 10 | AQ2 | AQ2 |
| 11 | Not used | AQ3 |
| 12 | Not used | AQ4 |

Each analog input on the unit has a single pole 345Hz (461µS) cutoff high frequency noise filter. In addition, a second digital filter may be specified in the first configuration word with the following time constants.

| Bit | | | Time Constant |
|-----|----|----|--|
| 15 | 14 | 13 | |
| 0 | 0 | 0 | 10 milliseconds (Nominal hardware scan rate) |
| 0 | 0 | 1 | 15 milliseconds |
| 0 | 1 | 0 | 35 milliseconds |
| 0 | 1 | 1 | 75 milliseconds |
| 1 | 0 | 0 | 155 milliseconds |
| 1 | 0 | 1 | 315 milliseconds |
| 1 | 1 | 0 | 635 milliseconds |
| 1 | 1 | 1 | 1.275 seconds |

This digital filter is useful for applications with significant amounts of random noise. The slower time constants, while yielding better noise suppression, take a longer time to settle after step changes and are also sensitive to impulse noise which is treated like Gaussian noise and averaged.

Bit 16 of the first configuration word may be set to specify an adaptive filter algorithm that:

1. Responds much more quickly to large step changes at slower time constants with full filtering of low level noise.
2. Suppresses impulse noise at the expense of slightly slower response at the shortest time constant settings. (Approximately 10 additional milliseconds)

Note that actual system response time is network dependent.

Bits 9 through 12 of the 5th configuration word control the behavior of the analog outputs when network communication is lost. The bit to channel correspondence is the same as for the mode and scale bits. If the corresponding bit is set, the outputs hold the last state. If the corresponding bit is cleared, the outputs are set to the respective value supplied to the unit in the second four words of the Consumed Directed Analog Data sent by the OCS. The other bits of the 5th configuration word are unused.

Refer the SmartStix Analog Programming Guide.

6 INPUT AND OUTPUT CONVERSION FACTORS

The following table describes how real-world values are scaled in the controller. For a given physical voltage or current, the register data value may be calculated by using the conversion factor from the table. The following formula is used: **Data = Voltage or Current / Conversion Factor**.

Example: The user selects a voltage range of ±10V:

1. The physical voltage is 6 Volts.
2. Using the table, the conversion factor for the voltage range of ±10V is .0003125.
3. To determine the data value, the formula is used: Data = V / Conversion Factor

$$19200 = 6 \text{ VDC} / 0.0003125$$

| Conversion between Physical Values and Register Values | | | |
|--|------------|---------------|-------------------|
| Selected Range | Volts / mA | Register Data | Conversion Factor |
| ±5.00 V | > +5.11 | 32767 | 0.00015625 |
| | +5.00 | 32000 | |
| | 0.00 | 0 | |
| | -5.00 | -32000 | |
| | < -5.11 | -32768 | |
| ±10.00 V | > +10.23 | 32767 | 0.0003125 |
| | +10.00 | 32000 | |
| | 0.00 | 0 | |
| | -10.00 | -32000 | |
| | < -10.23 | -32768 | |
| 4..20 mA | < +20.37 | 32767 | 0.0005 |
| | +20.00 | 32000 | |
| | +4.00 | 0 | |
| | -12.00 | -32000 | |
| | > -12.38 | -32768 | |
| ±20.00 mA | > +20.47 | 32767 | 0.0006250 |
| | +20.00 | 32000 | |
| | 0 | 0 | |
| | -20.00 | -32000 | |
| | < -20.47 | -32768 | |

Note: For the 4 to 20mA range, the offset, 4mA, must first be subtracted from the physical output value before dividing by the scale factor to yield the register data value.

7 SETTING ID SWITCHES

CsCAN Network IDs are set using the hexadecimal number system from 01 to FD. The decimal equivalent is 1-253. Refer to following Conversion Table, which shows the decimal equivalent of hexadecimal numbers. Set a unique Network ID by inserting a small Phillips screwdriver into the two *identical* switches.

Note: The CsCAN Baud Rate for SmartStix I/O is fixed at 125KBaud.

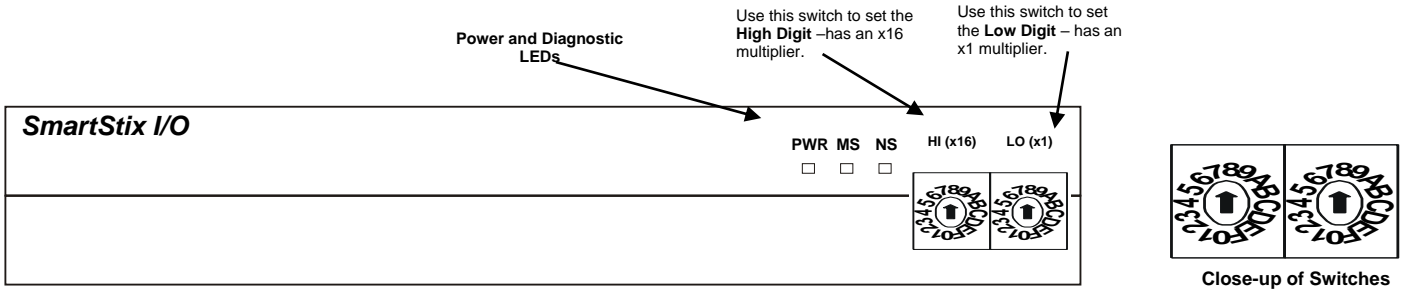

Decimal (Dec) to Hexadecimal (Hex) Conversion

| Dec | Hex | | Dec | Hex | | Dec | Hex | | Dec | Hex | | Dec | Hex | | Dec | Hex | |
|-----|-----|----|-----|-----|----|-----|-----|----|-----|-----|----|-----|-----|----|-----|-----|----|
| | HI | LO | | HI | LO | | HI | LO | | HI | LO | | HI | LO | | HI | LO |
| | | | 46 | 2 | E | 92 | 5 | C | 138 | 8 | A | 184 | B | 8 | 230 | E | 6 |
| 1 | 0 | 1 | 47 | 2 | F | 93 | 5 | D | 139 | 8 | B | 185 | B | 9 | 231 | E | 7 |
| 2 | 0 | 2 | 48 | 3 | 0 | 94 | 5 | E | 140 | 8 | C | 186 | B | A | 232 | E | 8 |
| 3 | 0 | 3 | 49 | 3 | 1 | 95 | 5 | F | 141 | 8 | D | 187 | B | B | 233 | E | 9 |
| 4 | 0 | 4 | 50 | 3 | 2 | 96 | 6 | 0 | 142 | 8 | E | 188 | B | C | 234 | E | A |
| 5 | 0 | 5 | 51 | 3 | 3 | 97 | 6 | 1 | 143 | 8 | F | 189 | B | D | 235 | E | B |
| 6 | 0 | 6 | 52 | 3 | 4 | 98 | 6 | 2 | 144 | 9 | 0 | 190 | B | E | 236 | E | C |
| 7 | 0 | 7 | 53 | 3 | 5 | 99 | 6 | 3 | 145 | 9 | 1 | 191 | B | F | 237 | E | D |
| 8 | 0 | 8 | 54 | 3 | 6 | 100 | 6 | 4 | 146 | 9 | 2 | 192 | C | 0 | 238 | E | E |
| 9 | 0 | 9 | 55 | 3 | 7 | 101 | 6 | 5 | 147 | 9 | 3 | 193 | C | 1 | 239 | E | F |
| 10 | 0 | A | 56 | 3 | 8 | 102 | 6 | 6 | 148 | 9 | 4 | 194 | C | 2 | 240 | F | 0 |
| 11 | 0 | B | 57 | 3 | 9 | 103 | 6 | 7 | 149 | 9 | 5 | 195 | C | 3 | 241 | F | 1 |
| 12 | 0 | C | 58 | 3 | A | 104 | 6 | 8 | 150 | 9 | 6 | 196 | C | 4 | 242 | F | 2 |
| 13 | 0 | D | 59 | 3 | B | 105 | 6 | 9 | 151 | 9 | 7 | 197 | C | 5 | 243 | F | 3 |
| 14 | 0 | E | 60 | 3 | C | 106 | 6 | A | 152 | 9 | 8 | 198 | C | 6 | 244 | F | 4 |
| 15 | 0 | F | 61 | 3 | D | 107 | 6 | B | 153 | 9 | 9 | 199 | C | 7 | 245 | F | 5 |
| 16 | 1 | 0 | 62 | 3 | E | 108 | 6 | C | 154 | 9 | A | 200 | C | 8 | 246 | F | 6 |
| 17 | 1 | 1 | 63 | 3 | F | 109 | 6 | D | 155 | 9 | B | 201 | C | 9 | 247 | F | 7 |
| 18 | 1 | 2 | 64 | 4 | 0 | 110 | 6 | E | 156 | 9 | C | 202 | C | A | 248 | F | 8 |
| 19 | 1 | 3 | 65 | 4 | 1 | 111 | 6 | F | 157 | 9 | D | 203 | C | B | 249 | F | 9 |
| 20 | 1 | 4 | 66 | 4 | 2 | 112 | 7 | 0 | 158 | 9 | E | 204 | C | C | 250 | F | A |
| 21 | 1 | 5 | 67 | 4 | 3 | 113 | 7 | 1 | 159 | 9 | F | 205 | C | D | 251 | F | B |
| 22 | 1 | 6 | 68 | 4 | 4 | 114 | 7 | 2 | 160 | A | 0 | 206 | C | E | 252 | F | C |
| 23 | 1 | 7 | 69 | 4 | 5 | 115 | 7 | 3 | 161 | A | 1 | 207 | C | F | 253 | F | D |
| 24 | 1 | 8 | 70 | 4 | 6 | 116 | 7 | 4 | 162 | A | 2 | 208 | D | 0 | | | |
| 25 | 1 | 9 | 71 | 4 | 7 | 117 | 7 | 5 | 163 | A | 3 | 209 | D | 1 | | | |
| 26 | 1 | A | 72 | 4 | 8 | 118 | 7 | 6 | 164 | A | 4 | 210 | D | 2 | | | |
| 27 | 1 | B | 73 | 4 | 9 | 119 | 7 | 7 | 165 | A | 5 | 211 | D | 3 | | | |
| 28 | 1 | C | 74 | 4 | A | 120 | 7 | 8 | 166 | A | 6 | 212 | D | 4 | | | |
| 29 | 1 | D | 75 | 4 | B | 121 | 7 | 9 | 167 | A | 7 | 213 | D | 5 | | | |
| 30 | 1 | E | 76 | 4 | C | 122 | 7 | A | 168 | A | 8 | 214 | D | 6 | | | |
| 31 | 1 | F | 77 | 4 | D | 123 | 7 | B | 169 | A | 9 | 215 | D | 7 | | | |
| 32 | 2 | 0 | 78 | 4 | E | 124 | 7 | C | 170 | A | A | 216 | D | 8 | | | |
| 33 | 2 | 1 | 79 | 4 | F | 125 | 7 | D | 171 | A | B | 217 | D | 9 | | | |
| 34 | 2 | 2 | 80 | 5 | 0 | 126 | 7 | E | 172 | A | C | 218 | D | A | | | |
| 35 | 2 | 3 | 81 | 5 | 1 | 127 | 7 | F | 173 | A | D | 219 | D | B | | | |
| 36 | 2 | 4 | 82 | 5 | 2 | 128 | 8 | 0 | 174 | A | E | 220 | D | C | | | |
| 37 | 2 | 5 | 83 | 5 | 3 | 129 | 8 | 1 | 175 | A | F | 221 | D | D | | | |
| 38 | 2 | 6 | 84 | 5 | 4 | 130 | 8 | 2 | 176 | B | 0 | 222 | D | E | | | |
| 39 | 2 | 7 | 85 | 5 | 5 | 131 | 8 | 3 | 177 | B | 1 | 223 | D | F | | | |
| 40 | 2 | 8 | 86 | 5 | 6 | 132 | 8 | 4 | 178 | B | 2 | 224 | E | 0 | | | |
| 41 | 2 | 9 | 87 | 5 | 7 | 133 | 8 | 5 | 179 | B | 3 | 225 | E | 1 | | | |
| 42 | 2 | A | 88 | 5 | 8 | 134 | 8 | 6 | 180 | B | 4 | 226 | E | 2 | | | |
| 43 | 2 | B | 89 | 5 | 9 | 135 | 8 | 7 | 181 | B | 5 | 227 | E | 3 | | | |
| 44 | 2 | C | 90 | 5 | A | 136 | 8 | 8 | 182 | B | 6 | 228 | E | 4 | | | |
| 45 | 2 | D | 91 | 5 | B | 137 | 8 | 9 | 183 | B | 7 | 229 | E | 5 | | | |

8 LEDS

SmartStix I/O Modules provide diagnostic and status LED indicators.

| a. Diagnostic LED Indicators | | | b. Status LED Indicators |
|--|----------------|---|---|
| Diagnostic LED | State | Meaning | |
| MS (Module Status) | Solid Red | RAM or ROM test failed | The Power Status LED illuminates Red when power is applied to the module. There are I/O Status LED indicators for each of the Digital I/O points, which illuminate Red when an I/O point is ON. |
| | Blinking Red | I/O test failed, internal hardware fault | |
| | Blinking Green | Module is in power-up state * | |
| | Solid Green | Module is running normally | |
| NS (Network Status) | Solid Red | Network Ack or Dup ID test failed ** | |
| | Blinking Red | Network ID test failed: ID not in the range of 1..253 | |
| | Blinking Green | Life Expectancy timeout, outputs are in default state *** | |
| | Solid Green | Network is running normally | |
| <p>* If a blinking green Module Status persists for more than a few seconds the module has not received the expected configuration from the OCS. This may be due to no Network I/O configuration created in Cscape, not having downloaded the Network I/O configuration to the master OCS, an unpowered master OCS, or the wrong Network ID number set on the module's rotary switches.</p> <p>** Network Ack means that no other node is active on the network. Dup ID test failed means that another node with the same ID switch setting is already on the network.</p> <p>*** Life Expectancy timeout means that the module has not received a periodic message from the master OCS in the time specified in either the Life Expectancy directed data message or the Comm timeout of the Network I/O Configuration window in Cscape.</p> | | | |

9 NETWORK CABLE

| | Pin | Description |
|--|-------|---------------|
| | RED 1 | V+ |
| | WHT 2 | CAN_H |
| | NC 3 | No Connection |
| | BLU 4 | CAN_L |
| | BLK 5 | V- |

| Recommended Cable | |
|------------------------------|--------------|
| Thick: (Max Distance = 500m) | Belden 3082A |
| Thin: (Max Distance = 100m) | Belden 3084A |

10 INSTALLATION / SAFETY

When found on the product, the following symbols specify:



Warning: Consult user documentation.



Warning: Electrical Shock Hazard.

WARNING: To avoid the risk of electric shock or burns, always connect the safety (or earth) ground before making any other connections.

WARNING: To reduce the risk of fire, electrical shock, or physical injury it is strongly recommended to fuse the voltage measurement inputs. Be sure to locate fuses as close to the source as possible.

WARNING: Replace fuse with the same type and rating to provide protection against risk of fire and shock hazards.

WARNING: In the event of repeated failure, do not replace the fuse again as a repeated failure indicates a defective condition that will not clear by replacing the fuse.

WARNING: Only qualified electrical personnel familiar with the construction and operation of this equipment and the hazards involved should install, adjust, operate, or service this equipment. Read and understand this manual and other applicable manuals in their entirety before proceeding. Failure to observe this precaution could result in severe bodily injury or loss of life.

For detailed installation and a handy checklist that covers panel box layout requirements and minimum clearances, refer to the hardware manual of the controller you are using. (See the **Additional References** section in this document.)

- All applicable codes and standards need to be followed in the installation of this product.
- For I/O wiring (discrete), use the following wire type or equivalent: Belden 8441 or equivalent.

Adhere to the following safety precautions whenever any type of connection is made to the module.

- Connect the green safety (earth) ground first before making any other connections.
- When connecting to electric circuits or pulse-initiating equipment, open their related breakers. Do not make connections to live power lines.
- Make connections to the module first; then connect to the circuit to be monitored.
- Route power wires in a safe manner in accordance with good practice and local codes.
- Wear proper personal protective equipment including safety glasses and insulated gloves when making connections to power circuits.
- Ensure hands, shoes, and floor are dry before making any connection to a power line.
- Make sure the unit is turned OFF before making connection to terminals. Make sure all circuits are de-energized before making connections.
- Before each use, inspect all cables for breaks or cracks in the insulation. Replace immediately if defective.

11 TECHNICAL ASSISTANCE

For assistance and manual updates, contact Technical Support at the following locations:

North America:
 Tel: 317 916-4274
 Fax: 317 639-4279
 Web: www.homerautomation.com
 Email: techspt@heapg.com

Europe:
 Tel: +353-21-4321266
 Fax: +353-21-4321826
 Web: <http://www.homerautomation.eu>
 Email: tech.support@homer-apg.com

Cscape, SmartStix and CsCAN are trademarks of Horner APG. This information is subject to change without notice.