



XLE MODEL



XLT MODEL

XLE & XLT OCS DATASHEET

MODEL 3:

Rev T or Later [Europe: XLEe - Rev R or later, XLTe - Rev K or Later]
12 DC In, 12 DC Out, 2 - 12-bit Analog In

1 TECHNICAL SPECIFICATIONS

XLEe and XLTe = Ethernet Versions

1.1 General

Primary Pwr. Range	10-30VDC
Required Power (Steady State)	130mA @ 24VDC
-22 Heater Option	250mA @ 24VDC with Heater Operating *Heater Option - Model# plus "-22"
Typical power-backlight 100%	164mA @ 10 (1.64W) 116mA @ 24V (2.77W)
Power Backlight Off	15mA @ 24V (0.36W)
Power Ethernet Models	35mA @ 10V (0.35W) 20mA @ 24V (0.48W)
Inrush Current	30A for < 1ms
Real Time Clock	Battery backed; lithium coin cell CR2450
Clock Accuracy	+/- 90 Secs/Month at 25°C.
Relative Humidity	5 to 95% Non-condensing
Operating Temp.	-10°C to +60°C
-22 Heater Option	-40°C to +50°C
Storage Temp.	-20°C to +60°C
Weight	0.75 lbs/340 g (without I/O)
Altitude	Up to 2000m
Rated Pollution Degree	Evaluated for Pollution Degree 2 rating
Certifications (UL/CE)	North America Europe

1.2 User Interface

Display Type	Transflective LCD Sunlight Readable
Resolution	128 x 64 pixels (XLE) 160 x 128 pixels (XLT)
Color	Monochrome
Built-In Storage	16MB
User-Program. Screens	1023 max pages; 50 objects per page
Backlight	LED
Backlight Lifetime	30,000+ hrs
Brightness Control	0-100% (XLT) On/Off (XLE) via System Register %SR57
Number of Keys	20 (XLEe) 5 (XLTe)
Touchscreen (XLTe)	Resistive 1,000,000+ touch life

1.3 Connectivity

Serial Ports	RS-232 full handshaking or RS-485 half duplex on first Modular Jack (MJ1) RS-232 or RS-485 on second Modular Jack (MJ2)
USB Mini-B	Programming only
CAN	1x CAN Port, Isolated 1kV
CAN Protocols	CsCAN, CANopen, DeviceNet, J1939
Ethernet	Ethernet versions only
Ethernet Protocols	TCP/IP, Modbus TCP, FTP, SRTP, EGD, ICMP, ASCII
Remote I/O	SmartRail, SmartStix, SmartBlock, SmartMod
Removable Memory	microSD, SDHC, SDXC IN FAT32 format, support for 32 GB max. Application Updates, Datalogging, and more
Audio (XLTe only)	Beeper, System or Software Controlled

1.4 Control & Logic

Control Lang. Support	Advanced Ladder Logic Full IEC 61131-3 Languages
Logic Program Size	256kB
Logic Scan Rate	0.7ms/kB (XLE) 0.8ms/kB (XLT)
Digital Inputs	2048
Digital Outputs	2048
Analog Inputs	512
Analog Outputs	512
Gen. Purpose Registers	9,999 (words) Retentive 2,048 (bits) Retentive 2,048 (bits) Non-retentive

1.5 High-Speed Inputs

Number of Counters	4
Maximum Frequency	500kHz each
Accumulator Size	32-bits each
Modes Supported	Totalizer, quadrature, pulse measurement, frequency measurement, set-point controlled outputs

1.6 High-Speed Outputs

Modes Supported	Stepper, PWM
Output Frequency	10kHz or 65kHz with HE-XHSQ

XLE/XLT User Manual [MAN0878]

The User Manual includes extensive information on:

- Built-In I-O
- Common %S & %SR Registers
- HSC/PWM/Totalizer/Quadrature & Accumulator Registers
- Resource Limits

technical specifications continued on next page...

technical specifications continued...

1.7 Digital DC Inputs

Inputs per Module	12 Including 4 Configurable HSC Inputs	
Commons per Module	1	
Input Voltage Range	12VDC / 24VDC	
Absolute Max. Voltage	30VDC Max.	
Input Impedance	10kΩ	
Input Current:	Positive Logic:	Negative Logic:
Upper Threshold	0.8mA	-1.6mA
Lower Threshold	0.3mA	-2.1mA
Max. Upper Threshold	8VDC	
Min. Lower Threshold	3VDC	
OFF to ON Response	1ms	
ON to OFF Response	1ms	
High Speed Counter Max Freq*	500kHz Max	

*See I/O info below for detail regarding HSC and PWM

1.8 Digital DC Outputs

Outputs per Module	12 Including 2 Configurable PWM Outputs
Commons per Module	1
Output Type	Sourcing / 10kΩ Pull-Down
Absolute Max. Voltage	28VDC Max.
Output Protection	Short Circuit
Max. Output Current/Point	0.5A
Max. Total Current	4A Continuous
Output Frequency	10kHz or 65kHz with HE-XHSQ
Max. Output Supply Voltage	30VDC
Min. Output Supply Voltage	10VDC
Max. Voltage Drop at Rated Current	0.25VDC
Max. Inrush Current	650mA per Channel
Min. Load	None
OFF to ON Response	1ms
ON to OFF Response	1ms
Output Characteristics	Current Sourcing (Pos. Logic)
PWM Out	≈ 5kHz
Rise Time	50 - 115μs
Fall Time	8-20μs

1.9 Analog Inputs

Number of Channels	2
Input Ranges	0 - 10VDC 0 - 20mA 4 - 20mA
Safe Input Range	-0.5V to +12V
Input Impedance (Clamped @ -0.5 Vdc to 12 Vdc)	Current Mode: 100Ω Voltage Mode: 500kΩ
Nominal Resolution	12 Bits
%AI full scale	0V, 20mA, 100mV: 32,000 counts full scale
Max. Over-Current	35mA
Conversion Speed	All channels converted once per ladder scan
Max. Error @25°C (excluding zero) Adjusting filter may improve error.	4-20mA 1.00% 0-20mA 1.00% 0-10VDC 0.50%
Filtering	160Hz hash (noise) filter 1-128 scan digital running average filter

2 CONTROLLER OVERVIEW

2.1 - Overview of XLE and XLT

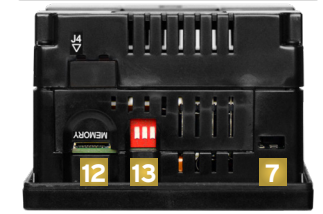
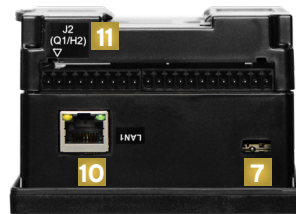
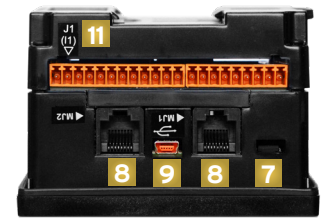
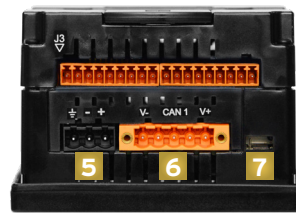
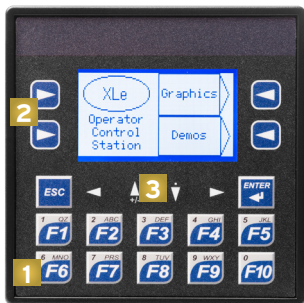

1. Function Keys
2. Softkeys
3. Navigation Keys
4. Touchscreen
5. Wide Range DC Power
6. CAN Port
7. Mounting Clip Locations
8. RS232/RS485 Serial Ports (2)
9. USB Mini-B Port
10. Ethernet LAN Port (optional)
11. Optional Built-In I/O
12. High Capacity microSD Slot
13. Configuration Switches
14. DIN Rail Clip

Wiring Details:
Solid/Stranded Wire: 12-24 awg (2.5-0.2mm²).
Strip Length: 0.28" (7mm).
Torque, Terminal Hold-Down Screws: 4.5 - 7 in-lbs (0.50 - 0.78 N-m).

NOTE: See Precaution #12 on page 6 about USB and grounding.

controller overview continued...

2.2 - Power Wiring

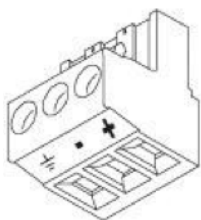

Primary Power Port Pins

PIN	SIGNAL	DESCRIPTION
1	Ground	Frame Ground
2	DC-	Input Power Supply Ground
3	DC+	Input Power Supply Voltage

DC Input / Frame

Solid/Stranded Wire: 12-24 awg (2.5-0.2mm).

Strip length: 0.28" (7mm).

Torque, Terminal Hold-Down Screws: 4.5 - 7 in-lbs (0.50 - 0.78 N-m).

DC- is internally connected to I/O V-, but is isolated from CAN V-. A Class 2 power supply must be used.

POWER UP

- OPTION: Attach ferrite core with a minimum of two turns of the DC+ and DC- signals from the DC supply that is powering the controllers.
- Connect to earth ground.
- Apply recommended power.



3 Wiring: Inputs and Outputs

3.1 - Analog Input Filtering

Raw input values for channels 1-4 are found in the registers as Integer-type data with a range from 0 - 32000.

Analog inputs may be filtered digitally with the Filter Constant found in the Cscape Hardware Configuration for Analog Inputs. Valid filter values are 0 - 7 and act according to the following chart.

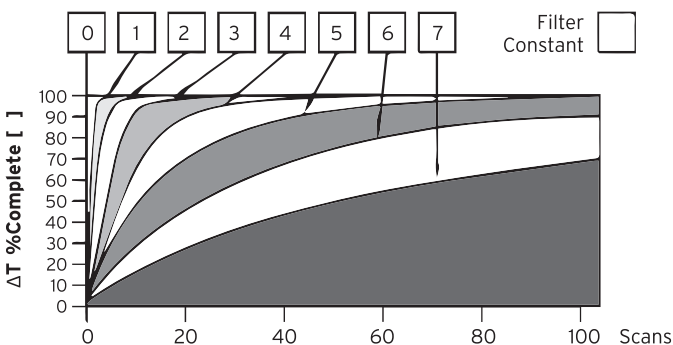

Data Values

INPUT MODE:	DATA FORMAT, 12-bit INT:
0-20mA, 4-20mA	0-32000
0-10V	0-32000

wiring: I-O continued...

3.2 - Digital Inputs

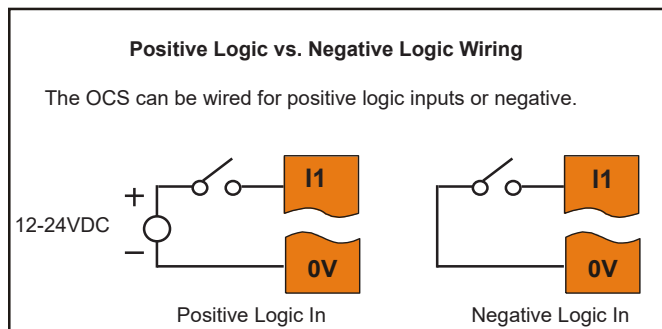

Digital inputs may be wired in either a Positive Logic or Negative Logic fashion as shown. The setting in the Cscape Hardware Configuration for the Digital Inputs must match the wiring used in order for the correct input states to be registered. P1 jumper settings are required for Pos/Neg setup. When used as a normal input and not for high speed functions, the state of the input is reflected in registers %I1 - %I12.P

Digital inputs may alternately be specified for use with High Speed Counter functions, also found in the Hardware Configuration for Digital Inputs. Refer to the XLE/XLT User Manual (MAN0878) for full details.

3.3 - Jumper Setting Locations for Model 3

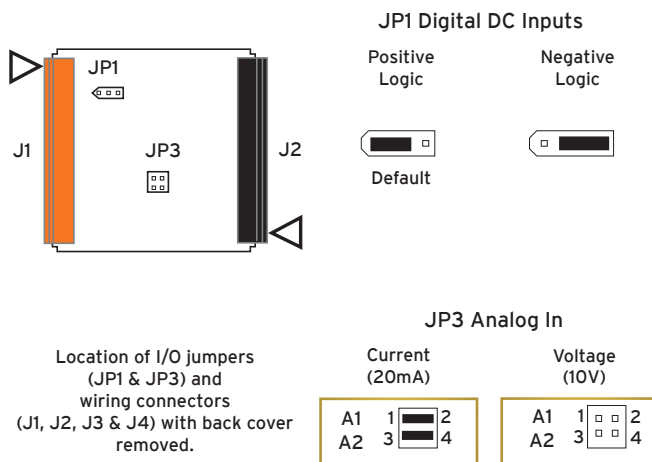

NOTE: The Cscape Module Configuration must match the selected I/O (JP) jumper settings. (Cscape Path: Controller -> Hardware Configuration -> Local I/O -> Config -> Module Setup -> Analog In)

NOTE: When using JP3 (A1-A2), each channel can be independently configured.

Back Panel Torque Rating for XLE/XLT: 3.0 - 4.0 in-lbs (0.34 - 0.45 N-m)

wiring: inputs & outputs continued...

3.4 - Wiring Connectors

J1 (Orange) Digital In/ Analog In

J1 (Orange) Name	
I1	IN1
I2	IN2
I3	IN3
I4	IN4
I5	IN5
I6	IN6
I7	IN7
I8	IN8
H1	HSC1 / IN9
H2	HSC2 / IN10
H3	HSC3 / IN11
H4	HSC4 / IN12
A1	Analog IN1
A2	Analog IN2
OV	Common

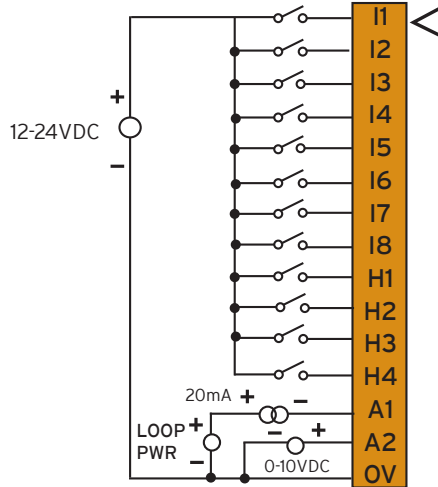

20mA Analog In - Not Self Powered

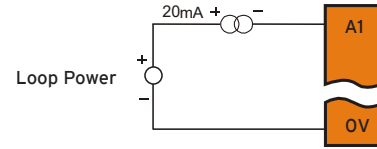

20mA Analog In - Self Powered

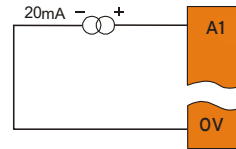

0-10VDC IN

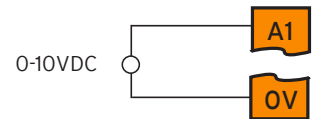

4 COMMUNICATIONS

4.1 - CAN Communications

CAN Pin Assignments

PIN	SIGNAL	DESCRIPTION
1	V-	CAN Ground - Black
2	CN L	CAN Data Low - Blue
3	SHLD	Shield Ground - None
4	CN H	CAN Data High - White
5	V+ (NC)	No Connect - Red

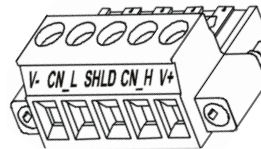

CAN

Solid/Stranded Wire: 12-24 awg (2.5-0.2mm)

Strip Length: 0.28" (7mm)

Locking spring-clamp, two-terminators per conductor

Torque, Terminal Hold-Down Screws: 4.5 - 7 in-lbs (0.50 - 0.78 N-m)

V+ pin is not internally connected, the SHLD pin is connected to Earth ground via a 1MΩ resistor and 10 nF capacitor.

4.2 - Dip Switches

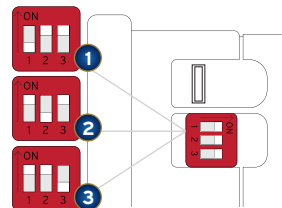

The DIP switches are used to provide a built-in termination to both the MJ1 port and MJ2 port if needed. The termination for these ports should only be used if this device is located at either end of the multidrop/daisy-chained RS-485 network.

DIP SWITCHES

PIN	NAME	FUNCTION	DEFAULT
1	MJ1 RS-485 Termination	ON = Terminated	OFF
2	MJ2 RS-485 Termination	ON = Terminated	OFF
3	Bootload	Always Off	OFF

J2 (Black) Digital Out

J2 (Black) Name	
OV	Common
V+	V+
NC	No Connect
Q12	OUT 12
Q11	OUT 11
Q10	OUT 10
Q9	OUT 9
Q8	OUT 8
Q7	OUT 7
Q6	OUT 6
Q5	OUT 5
Q4	OUT 4
Q3	OUT 3
Q2	OUT2/PWM2
Q1	OUT1/PWM1

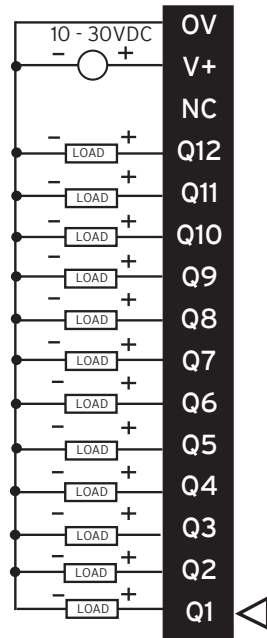

communications continued...

4.3 - Ethernet Communications

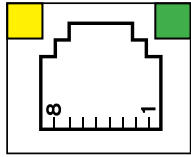

Green LED indicates link - when illuminated, data communication is available.

Yellow LED indicates activity - when flashing, data is in transmission.

4.4 - Serial Communications

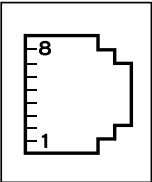

MJ1: RS-232 w/full handshaking or RS-485 half-duplex

RS-485 termination via switches; biasing via software

MJ1 PINS

PIN	SIGNAL	DIRECTION
8	TXD	OUT
7	RXD	IN
6	0V	GROUND
5	+5V @ 60mA	OUT
4	RTS	OUT
3	CTS	IN
2	RX-/TX-	IN/OUT
1	RX+/TX+	IN/OUT

MJ2 PINS

PIN	SIGNAL	DIRECTION
8	232 TXD	OUT
7	232 RXD	IN
6	0V	Ground
5	+5V @ 60mA	OUT
4	485 TX-	OUT
3	485 TX+	OUT
2	485 RX- or RX/TX-	IN or IN/OUT
1	485 RX+ or RX/TX+	IN or IN/OUT

MJ2 SERIAL PORT

MJ2: RS-232 or RS-485 half or full-duplex, software selectable

RS-485 termination via switches; biasing via software

Attach optional ferrite core with a minimum of two turns of serial cable. See website for more details. [Part #: HE-FBD001]

5 BUILT-IN I/O for Model 3

The I/O is mapped into OCS Register space, in three separate areas: Digital/Analog I/O, High-Speed Counter I/O, and High-speed Output I/O. Digital/Analog I/O location is fixed starting at 1, but the high-speed counter and high-speed output references may be mapped to any open register location. For more details, see the XLE/XLT OCS User's Manual (MAN0878).

Digital and Analog I/O Functions

Digital Inputs	%I1-12
Reserved	%I13-31
ESCP Alarm	%I32
Digital Outputs	%Q1-12
Reserved	%Q13-24
Analog Inputs	%AI1-2
Reserved	%AI3-12
Analog Outputs	n/a
Reserved	%AQ1-8

6 DIMENSIONS & INSTALLATION

6.1 - Dimensions

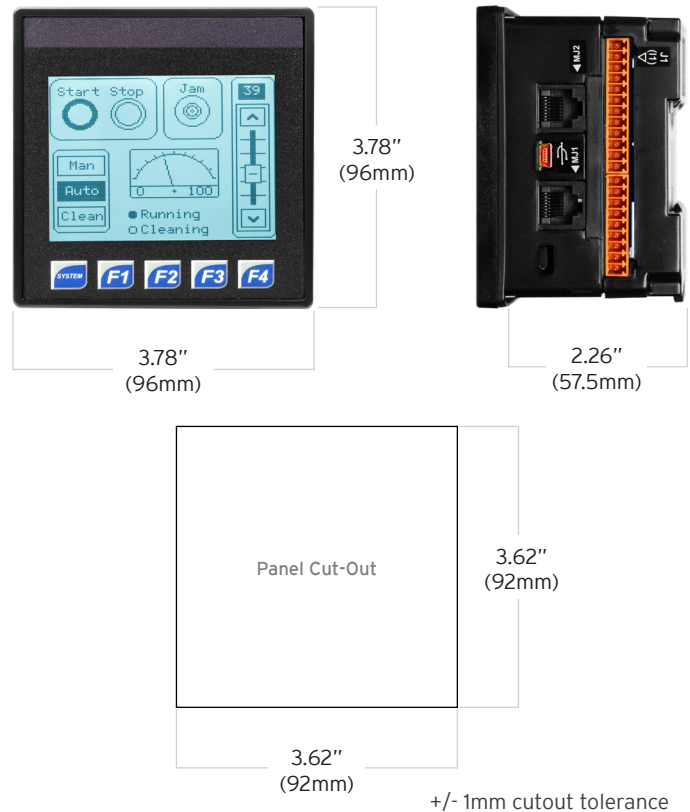

6.2 - Installation Procedure

- The XLE/XLT utilizes a clip installation method to ensure a robust and watertight seal to the enclosure. Please follow the steps below for the proper installation and operation of the unit.
 - This equipment is suitable for Class I, Division 2, Groups A, B, C and D or non-hazardous locations only.
 - Digital outputs shall be supplied from the same source as the operator control station.
 - Jumpers on connector JP1 shall not be removed or replaced while the circuit is live unless the area is known to be free of ignitable concentrations of flammable gases or vapors.
- Carefully locate an appropriate place to mount the XLE/XLT. Be sure to leave enough room at the top of the unit for insertion and removal of the microSD card.
 - Carefully cut the host panel per the diagram, creating a 92mm x 92mm +/-0.1mm opening into which the XLEe/XLTe may be installed. If the opening is too large, water may leak into the enclosure, potentially damaging the unit. If the opening is too small, the OCS may not fit through the hole without damage.
 - Remove any burrs and or sharp edges and ensure the panel is not warped in the cutting process.
 - Remove all Removable Terminals from the XLE/XLT. Insert the XLE/XLT through the panel cutout (from the front). The gasket must be between the host panel and the XLE/XLT
 - Install and tighten the four mounting clips (provided in the box) until the gasket forms a tight seal. (NOTE: Max torque 0.8 to 1.13 N m, or 7-10 in-lbs).
 - Reinstall the XLE/XLT I/O Removable Terminal Blocks. Connect communications cables to the serial port, USB ports, Ethernet port, and CAN port as required.

7 SAFETY

7.1 - WARNINGS

1. To avoid the risk of electric shock or burns, always connect the safety (or earth) ground before making any other connections.
2. To reduce the risk of fire, electrical shock, or physical injury, it is strongly recommended to fuse the voltage measurement inputs. Be sure to locate fuses as close to the source as possible.
3. Replace fuse with the same type and rating to provide protection against risk of fire and shock hazards.
4. In the event of repeated failure, do NOT replace the fuse again as repeated failure indicates a defective condition that will NOT clear by replacing the fuse.
5. Only qualified electrical personnel familiar with the construction and operation of this equipment and the hazards involved should install, adjust, operate, or service this equipment. Read and understand this manual and other applicable manuals in their entirety before proceeding. Failure to observe this precaution could result in severe bodily injury or loss of life.
6. **WARNING** - Battery may explode if mistreated. Do not recharge, disassemble, or dispose of in fire.
7. **WARNING - EXPLOSION HAZARD** - Batteries must only be changed in an area known to be non-hazardous.

7.2 - FCC COMPLIANCE

This device complies with Part 15 of the FCC Rules. Operation is subject to the following two conditions:

1. This device may not cause harmful interference
2. This device must accept any interference received, including interference that may cause undesired operation

7.3 - PRECAUTIONS

All applicable codes and standards need to be followed in the installation of this product. Adhere to the following safety precautions whenever any type of connection is made to the module:

1. Connect the safety (earth) ground on the power connector first before making any other connections.
2. When connecting to the electric circuits or pulse-initiating equipment, open their related breakers.
3. Do NOT make connection to live power lines.
4. Make connections to the module first; then connect to the circuit to be monitored.
5. Route power wires in a safe manner in accordance with good practice and local codes.
6. Wear proper personal protective equipment including safety glasses and insulated gloves when making connections to power circuits.
7. Ensure hands, shoes, and floor are dry before making any connection to a power line.
8. Make sure the unit is turned OFF before making connection to terminals.
9. Make sure all circuits are de-energized before making connections.
10. Before each use, inspect all cables for breaks or cracks in the insulation. Replace immediately if defective.
11. Use copper conductors in Field Wiring only, 60/75°C.
12. Use caution when connecting controllers to PCs via serial or USB. PCs, especially laptops, may use "floating power supplies" that are ungrounded. This could cause a damaging voltage potential between the laptop and controller. Ensure the controller and laptop are grounded for maximum protection. Consider using a USB isolator due to voltage potential differences as a preventative measure.

8 ANALOG IN TRANZORB FAILURE

A common cause of Analog Input Tranzorb Failure on Analog Inputs Models 2, 3, 4 & 5: If a 4- 20mA circuit is initially wired with loop power, but without a load, the analog input could see 24VDC. This is higher than the rating of the tranzorb. This can be solved by NOT connecting loop power prior to load connection, or by installing a low-cost PTC in series between the load and analog input.

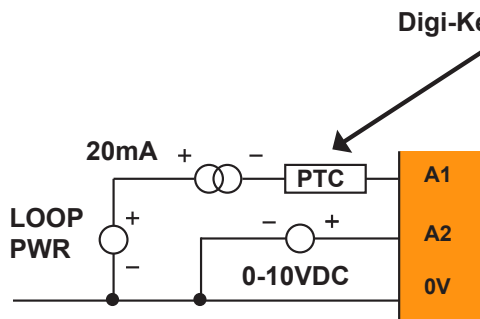

9 BATTERY MAINTENANCE

The XLE/XLT uses a replaceable non-rechargeable 3V Lithium coin cell battery (CR2450) to run the Real-Time Clock and to keep the retained register values. This battery is designed to maintain the clock and memory for 7 to 10 years. Please reference MAN0878 providing instructions on how to replace the battery.

10 ACCESSORIES

10.1 Backup Battery: HE-BAT009

The XLE and XLT use a lithium battery [CR2450] to run the Real-Time Clock and to maintain the retained register values. This battery is designed to maintain the clock and memory for 7-10 years.

10.2 Programming Cables Kit: HE-XCK

This programming cable kit includes the following adapter cables:

- USB to MiniUSB
- USB to RS-232 Serial
- RS-232 Serial to RJ45 Ethernet

10.3 2/4 Channel Analog Output Kit

- HE-XDAC007 - 2 Channel Analog Output I/O Kit
- HE-XDAC107 - 4 Channel Analog Output I/O Kit

Visit the Horner Website to purchase accessories.

11 PART NUMBER BUILDER

GLOBAL MODEL NUMBERS

screen	Ethernet	I/O
HE-XL <input style="width: 40px;" type="text"/>	1 <input style="width: 40px;" type="text"/>	<input style="width: 40px;" type="text"/>
E (no touchscreen) T (touchscreen)	O (no Ethernet) E (Ethernet)	0 (model 0) 2 (model 2) 3 (model 3) 4 (model 4) 5 (model 5) 6 (model 6)

EUROPEAN MODEL NUMBERS

screen	Ethernet	CAN option	I/O	overlay type
HEX <input style="width: 40px;" type="text"/>	<input style="width: 40px;" type="text"/>	C <input style="width: 40px;" type="text"/>	<input style="width: 40px;" type="text"/>	- <input style="width: 40px;" type="text"/>
E22 (no touchscreen) T24 (touchscreen)	O (no Ethernet) 1 (Ethernet)	0 (no CAN*) 1 (CsCAN) 2 (CANopen) 4 (DeviceNet) 5 (J1939)	00 (model 0) 12 (model 2) 13 (model 3) 14 (model 4) 15 (model 5) 16 (model 6)	00 (dark colour) 01 (light colour) 02 (blank) 03-99 (custom)

*No CAN is only available on XLE

12 TECHNICAL SUPPORT

For assistance and manual updates, contact Technical Support at the following locations:

North America

+1 (317) 916-4274
(877) 665-5666
www.hornerautomation.com
techsppt@heapg.com

Europe

+353 (21) 4321-266
www.hornerautomation.eu
technical.support@horner-apg.com