

RCC SERIES QUICK REFERENCE GUIDE

RCC	Real Time Clock	DC In 12/24VAC	DC Out 24VDC	Analog In 0-20mA	Analog Out 0-20mA
RCC972	No	8	4	8	4
RCC8842	Yes	8	8	4	2
RCC2414	Yes	2	4	1	4
RCC1410	Yes	14	10	-	-

1. General Specifications

RCC972 Required Power (Steady State)	130mA @ 24VDC
RCC1410 Required Power (Steady State)	120mA @ 24VDC
RCC2414 Required Power (Steady State)	120mA @ 24VDC
RCC8842 Required Power (Steady State)	120mA @ 24VDC
Inrush Current	RCC972: 30A for 1ms @ 24VDC RCC1410: 25A for 1ms @ 24VDC switched RCC2414: 25A for 1ms @ 24VDC switched RCC8842: 25A for 1ms @ 24VDC switched
Primary Power Range	RCC972: 10-32VDC RCC1410: 10-32VDC RCC2414: 10-28VDC RCC8842: 10-32VDC
Relative Humidity	5 to 95% Non-condensing
Operating Temp.	-10°C to +60°C
Storage Temp.	-20°C to +70°C
Weight	10 oz (283.5g)
Certifications (CE)	USA: https://hornerautomation.com/certifications/ Europe: https://www.hornerautomation.eu/support/certifications-2/

2. Port Connectors

HE-RCC972

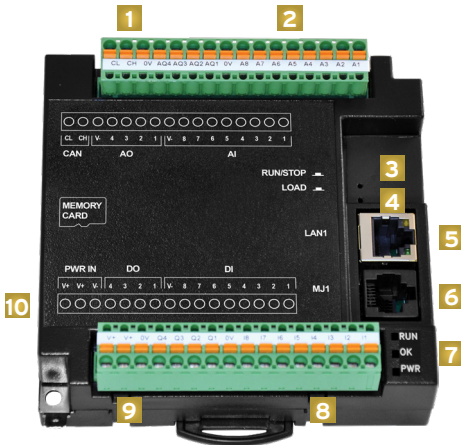

- CAN Port Connector
- I/O Connector (A)
- Run/Idle Switch
- Load Switch
- Ethernet Port(s)
- Serial Port(s)
- Status LEDs
- I/O Connector (B)
- Power Connector
- microSD Memory Card
- Mini-USB Programming
- USB Flash Memory

NOTE: See Precaution #12 about USB and grounding.

HE-RCC1410

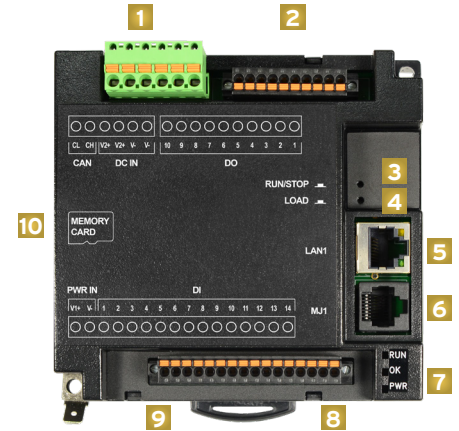

HE-RCC2414

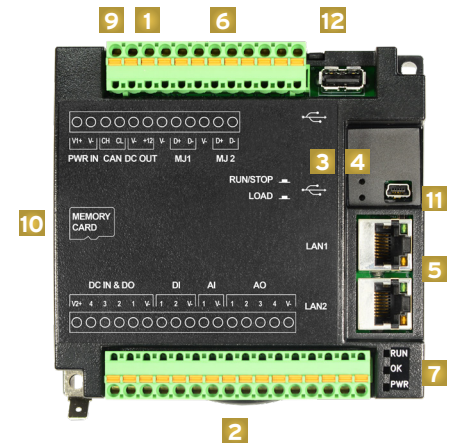

HE-RCC8842

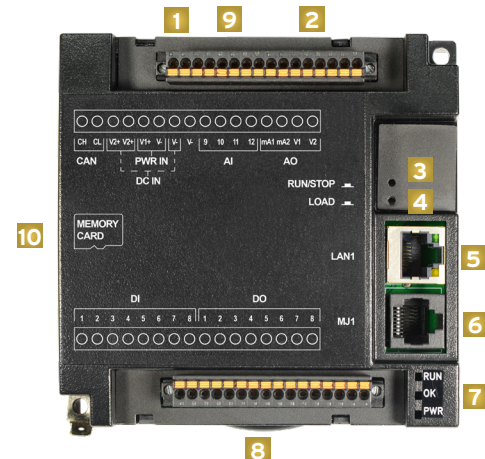

3. Wiring: Input/ Output

HE-RCC972:

8 Digital Inputs; 4 Digital Outputs
8 Analog Inputs; 4 Analog Outputs

Digital I/O	
V+	DC Power In
V+	24VDC Out
C	OV
Q4	Digital Out4
Q3	Digital Out3
Q2	Digital Out2
Q1	Digital Out1
C	OV
I8	Digital In8
I7	Digital In7
I6	Digital In6
I5	Digital In5
I4	Digital In4
I3	Digital In3
I2	Digital In2
I1	Digital In1

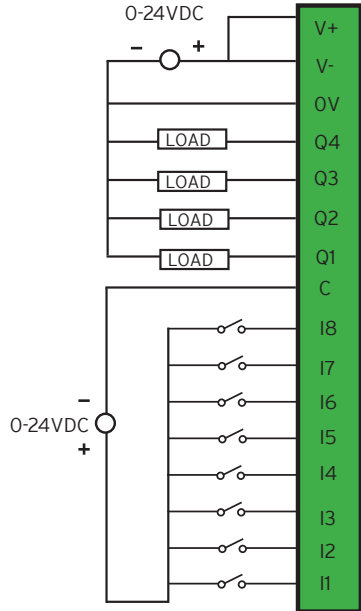

Analog I/O	
1	Analog In1
2	Analog In2
3	Analog In3
4	Analog In4
5	Analog In5
6	Analog In6
7	Analog In7
8	Analog In8
C	OV
1	Analog Out1
2	Analog Out2
3	Analog Out3
4	Analog Out4
OV	OV
CH	CAN High
CL	CAN Low

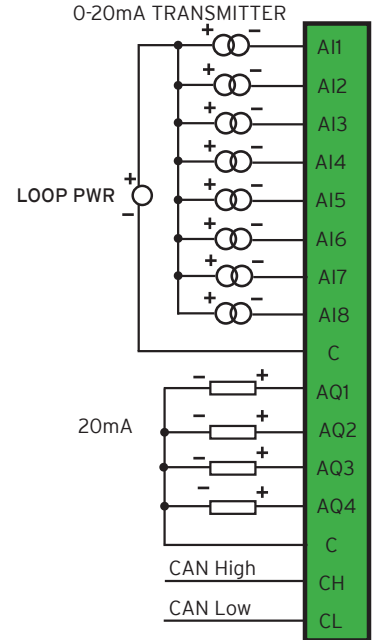

Power Wiring

To power up the RCC972, supply 10-32VDC to the V+ and C connections on the Power & Input connector..

HE-RCC1410:

14 Digital Inputs; 10 Digital Outputs

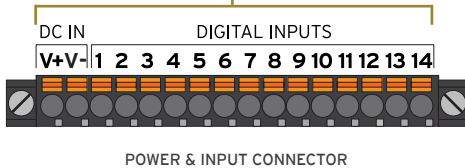
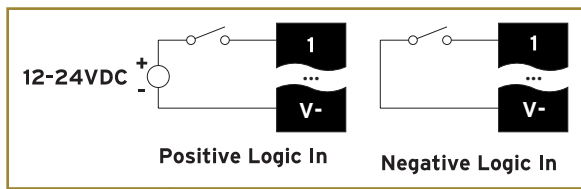

POSITIVE LOGIC vs. NEGATIVE LOGIC WIRING:
The RCC can be wired for Positive Logic inputs or Negative Logic inputs.

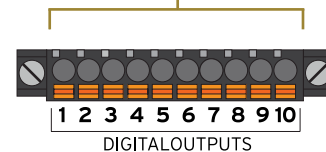
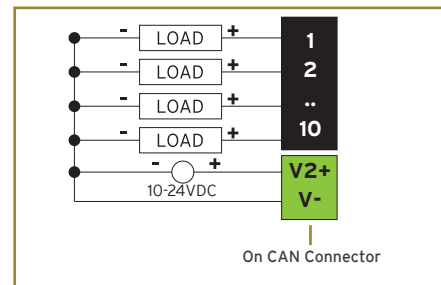

Power Wiring

To power up the RCC1410, supply 10-32VDC to the V+ and C connections on the Power & Input connector.

wiring: I/O continued....

HE-RCC2414:

2 Digital Inputs; 4 Digital Outputs
1 Analog Inputs; 4 Analog Outputs

Digital Input Wiring

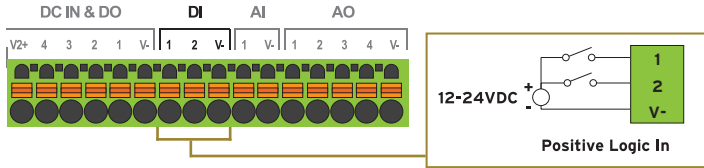

Digital Output Wiring

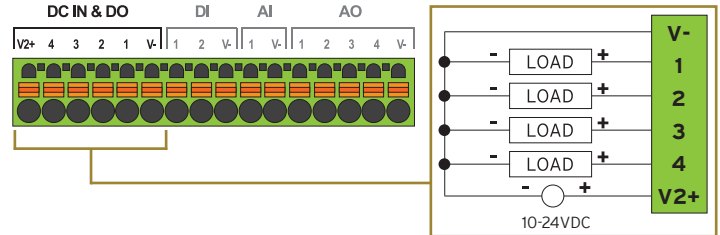

Analog Input Wiring

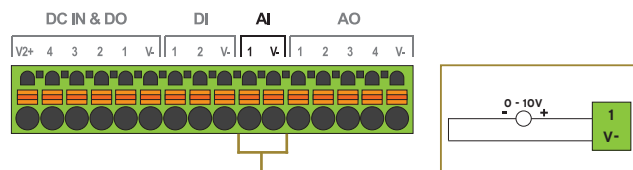

Analog Output Wiring

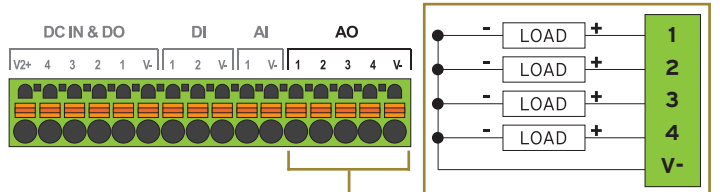

Power Wiring

To power up the RCC2414, supply 20-28VDC to the V+ and V- connections on the Power and Comms Connector. Additionally, a 12 V source is provided at the +12 terminal that is capable of 1 A maximum current.

HE-RCC8842:

8 Digital Inputs; 8 Digital Outputs
4 Analog Inputs; 2 Analog Outputs

Digital Input Wiring

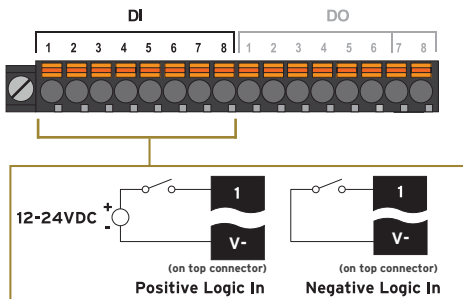

Digital Output Wiring

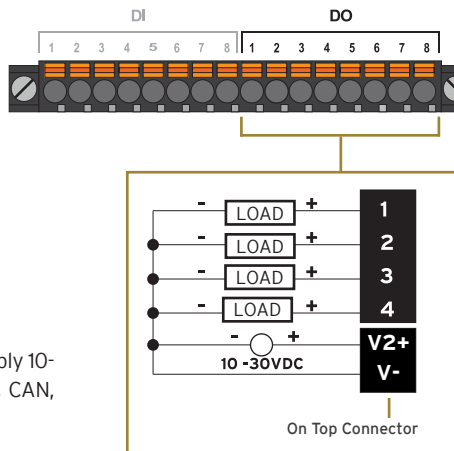

Analog Input Wiring

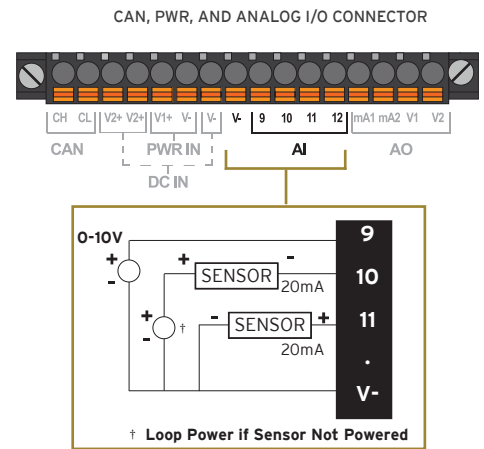

Power Wiring - To power up the RCC8842, supply 10-32VDC to the V+ and V- connections on the Power, CAN, and Analog Connector.

4. Documentation

Series Number	Datasheet/ Manual
RCC972	MAN1200/ MAN1078
RCC1410	MAN1034/ MAN1078
RCC2414	MAN1033/ MAN1078
RCC8842	MAN1073/ MAN1078

5. Battery Information

RCC972

The RCC972 does not have a battery.

RCC1410, RCC2414, RCC8842

The battery is designed to maintain the clock and memory for 7-10 years. Refer to MAN1078 on the Horner Website for more information about the battery.

6. Dimensions

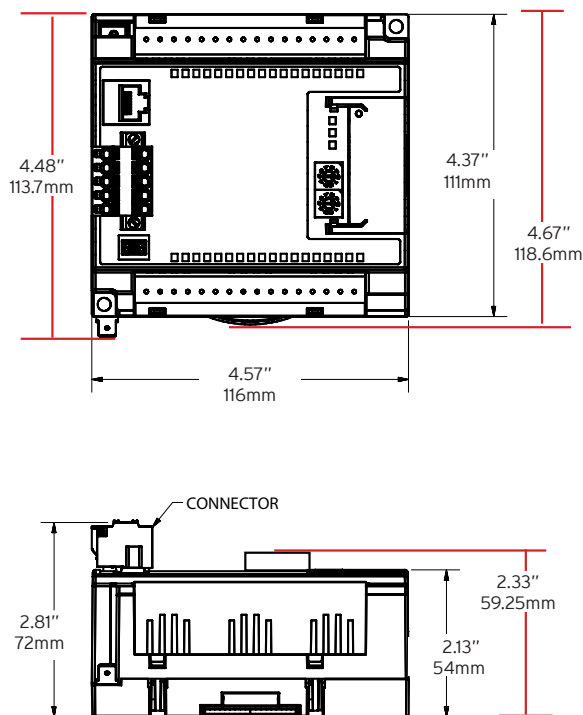

7. Installation Instructions

These RCC modules are suitable for use in the Class I, Division 2, Groups A, B, C and D Hazardous Locations only.

WARNING - EXPLOSION HAZARD - DO NOT DISCONNECT EQUIPMENT UNLESS POWER HAS BEEN SWITCHED OFF OR THE AREA IS KNOWN TO BE NON-HAZARDOUS.

ATTENTION - RISQUE D'EXPLOSION - NE DÉBRANCHEZ PAS L'ÉQUIPEMENT SAUF SI L'ALIMENTATION A ÉTÉ COUPÉE OU SI LA ZONE N'EST PAS DANGEREUSE.

Devices shall be installed into an enclosure suitable for the environment that is only accessible with the use of a tool.

INSTALLATION PROCEDURE

1. The RCC modules conveniently mount on a DIN rail.
2. Be sure the DIN rail is in a horizontal position before installing the unit.
3. The orientation shown to the right is necessary to prevent the unit from slipping off the DIN rail.
4. Align the unit on the DIN rail then push the DIN rail clip until it clicks into place. Check to ensure that the unit is secure on the DIN rail.
5. Do NOT mount the unit on its side as this may cause the unit from slipping off the DIN rail.

NOTE: The spade connector for grounding and the DIN rail clip add to the overall measurements. The CAN/PWR and LAN connectors also add to the measurements.

NOTE: Screw holes and a spade connector are available for a mounting option.

FCC COMPLIANCE

This device complies with part 15 of the FCC Rules. Operation is subject to the following two conditions:

1. This device may not cause harmful interference
2. This device must accept any interference received, including interference that may cause undesired operation

PRECAUTIONS

All applicable codes and standards need to be followed in the installation of this product. Adhere to the following safety precautions whenever any type of connection is made to the module:

1. Connect the safety (earth) ground on the power connector first before making any other connections.
2. When connecting to the electric circuits or pulse-initiating equipment, open their related breakers.
3. Do NOT make connection to live power lines.
4. Make connections to the module first; then connect to the circuit to be monitored.
5. Route power wires in a safe manner in accordance with good practice and local codes.
6. Wear proper personal protective equipment including safety glasses and insulated gloves when making connections to power circuits.
7. Ensure hands, shoes, and floor are dry before making any connection to a power line.
8. Make sure the unit is turned OFF before making connection to terminals.
9. Make sure all circuits are de-energized before making connections.
10. Before each use, inspect all cables for breaks or cracks in the insulation. Replace immediately if defective.
11. Use copper conductors in Field Wiring only, 60/75°C.
12. Use caution when connecting controllers to PCs via serial or USB. PCs, especially laptops, may use "floating power supplies: that are ungrounded. This could cause a damaging voltage potential between the laptop and controller. Ensure the controller and laptop are grounded for maximum protection. Consider using a USB isolator due to voltage potential differences as a preventative measure.

WARNINGS

1. To avoid the risk of electric shock or burns, always connect the safety (or earth) ground before making any other connections.
2. To reduce the risk of fire, electrical shock, or physical injury, it is strongly recommended to fuse the voltage measurement inputs. Be sure to locate fuses as close to the source as possible.
3. Replace fuse with the same type and rating to provide protection against risk of fire and shock hazards.
4. In the event of repeated failure, do NOT replace the fuse again as repeated failure indicates a defective condition that will NOT clear by replacing the fuse.
5. Only qualified electrical personnel familiar with the construction and operation of this equipment and the hazards involved should install, adjust, operate, or service this equipment. Read and understand this manual and other applicable manuals in their entirety before proceeding. Failure to observe this precaution could result in severe bodily injury or loss of life.

TECHNICAL SUPPORT

For assistance and manual updates, contact Technical Support at the following locations:

North America
+1 (317) 916-4274
(877) 665-5666
www.hornerautomation.com
techsppt@heapg.com

Europe
+353 (21) 4321-266
www.horner-apg.com
technical.support@horner-apg.com