

RMI5001

Installation Guide

Introduction

Thank you for purchasing a Maple Systems RMI5001 non-display HMI with HDMI® port. The RMI5001 is configured using the EZwarePlus software (purchased separately). This booklet describes the steps necessary for installing the RMI5001.

For information on programming and configuring the HMI, please refer to the **EZwarePlus Programming Manual** (P/N 1010-1015) available for download from the Maple Systems website.

For additional information, please refer to the Support Center section of the Maple Systems website, www.maplesystems.com. The Support Center provides links to information such as Manuals, FAQs, Technical Notes, Training Videos, Sample Projects, Controller Information Sheets, and Controller Cables.

Static Awareness

Do NOT remove the cover of your RMI5001 product – doing so will void your warranty. When the cover is removed the circuitry inside is exposed to possible damage by electrostatic discharge during handling. Minimize the possibility of electrostatic discharge by:

- Discharging personal static by grounding yourself prior to handling the HMI.
- Handling the HMI at a static-free grounded workstation.
- Connecting the frame ground (\perp) connector of the HMI to a clean earth ground.
- Placing the HMI in an antistatic bag during transport.

Unpacking the Unit

Carefully unpack the HMI. Check all material in the container against the packing list. Maple Systems will not accept responsibility for shortages against the packing list unless notified within 30 days. The equipment and accessories were inspected and tested by Maple Systems before shipment. Examine the equipment carefully; if any shipping damage is evident, notify the carrier immediately. Maple Systems is not responsible for claim negotiations with the carrier. Save the shipping container and packing material in case the equipment needs to be stored, returned to Maple Systems, or transported for any reason.

Packing List
RMI5001 Series HMI
Power Connector
RMI5001 Installation Guide

Warranty

A copy of the Warranty and Limitation of Liability is contained in the product box. It can also be found on our website.

Technical Support

This manual is designed to provide the necessary information for trouble-free installation and operation of the HMI. For assistance, please contact Maple Systems as follows:

- Phone: 425-745-3229
- Email: support@maplesystems.com
- Web: www.maplesystems.com

Installation of HMIs

Information furnished by Maple Systems, Inc., is believed to be accurate and reliable. However, no responsibility is assumed by Maple Systems for the use of this information, or for any infringements of patents or other rights of third parties which may result from its use. No license is granted by implication, or otherwise, under any patent or patent rights of Maple Systems, Inc. Maple Systems retains the right to revise or change its products and documentation at any time without notice.

CE Compliance

The RMI5001 has been tested to conform to European CE requirements, which meet or exceed the noise emissions and immunity requirements as set forth in the EN55022 (Emissions) and EN55024 (Immunity) standards. The products are designed to withstand electrical noise in harsh industrial environments. They also conform to requirements that limit electrical emissions. However, this does not guarantee that the products will be totally immune from possible malfunction in cases where severe electrical noise occurs.

Therefore, we strongly recommend that you follow the guidelines outlined in this guide for proper wire routing and grounding to ensure the proper operation of your unit.

Environmental Considerations

The RMI5001 is designed to be mounted inside an enclosure rated for the installation.

The RMI5001 operates in temperatures from -20° to 55°C (-4° to 131°F). It is intended for indoor installations and may not be suitable for use in certain outdoor applications. Avoid installing the RMI5001 in environments with severe mechanical vibration or shocks. Do not install the HMI in enclosures with rapid temperature variations or high humidity. Either case will cause condensation of water inside the device and eventual damage to the HMI.

- ⚠ **Warning:** *Do not operate the HMI in areas subject to explosion due to flammable gases, vapors, or dusts.*
- ⚠ **Warning:** *Conform to UL508 (ISBN 0-7629-0404-6) machine safety standards for use in Pollution Degree 2 Environments.*
- ⚠ **Warning:** *If wiring can potentially be exposed to lightning or power surges, use appropriate surge suppression devices.*

Safety Precautions

Please observe the following precautions when installing the HMI. Failure to comply with these restrictions could result in loss of life, serious personal injury, or equipment damage.

- ⚠ **Warning:** *Do not connect the HMI to an AC power source. This will cause permanent damage to the HMI.*
- ⚠ **Warning:** *A Hard-wired EMERGENCY STOP should be fitted in any system using an HMI to comply with ICS Safety Recommendations.*
- ⚠ **Warning:** *Do not attempt to use a DC power supply that does not meet HMI power requirements. You may cause malfunction or permanent damage to the HMI.*
- ⚠ **Warning:** *Do not power the HMI with a DC power supply used for inductive loads or for input circuitry to the programmable logic controller. Severe voltage spikes caused by these devices may damage the HMI.*

Control Panel Design Guidelines

Pay careful attention to the placement of system components and associated cable routing. These items can significantly enhance the performance and integrity of your control application.

Cable Routing and Noise Immunity

Follow these guidelines when routing cables to the HMI:

- Always route the HMI communication cable and the power cable away from any AC voltage or rapidly switching DC control lines.
- Never bundle the HMI cables together with 120VAC power wires or with relay wiring.
- Try to keep at least 8 inches (20 cm) of separation between the HMI cables and other power wiring. If voltages greater than 120VAC are used in the system, greater separation is required.
- If the HMI cables must come near AC wiring, make sure they cross at 90 degrees.
- Run AC power wires in a separate grounded conduit to reduce electrical noise interference.
- Keep the cable lengths for the HMI as short as possible. Do not coil excess cable and place it next to AC powered equipment.
- Cover any equipment used in the enclosure that operates at high frequency or high current levels with a grounded metal shield.

Power Supply Selection

The power supply used to power the HMI should provide an output of +24 VDC $\pm 20\%$ measured at the HMI power terminal block. A 24VDC regulated power supply *dedicated to the HMI* is recommended. Use a power supply with adequate current rating based upon your particular model (visit the Support Center Specifications page on our website).

A power line filter installed at the AC input to the HMI power supply is highly recommended as a safeguard against conducted RF noise, which is often present on factory power lines. The wires connecting the output of the power line filter to the power supply should be kept as short as possible to minimize any additional noise pickup. The case of the power line filter should be connected to a quiet earth ground. The power line filter should have a current rating of at least 3 Amps with common mode and differential mode attenuation. In applications that may have high frequency noise present, we also recommend using a resistor ($\sim 1 \text{ M}\Omega$) and capacitor ($\sim 4700 \text{ pF}$) in parallel to clean earth ground on the DC output of the power supply.

Do not use the power supply used to provide power to the HMI to power switching relays, solenoids, or other active devices.

Figure 1: Typical Panel Layout

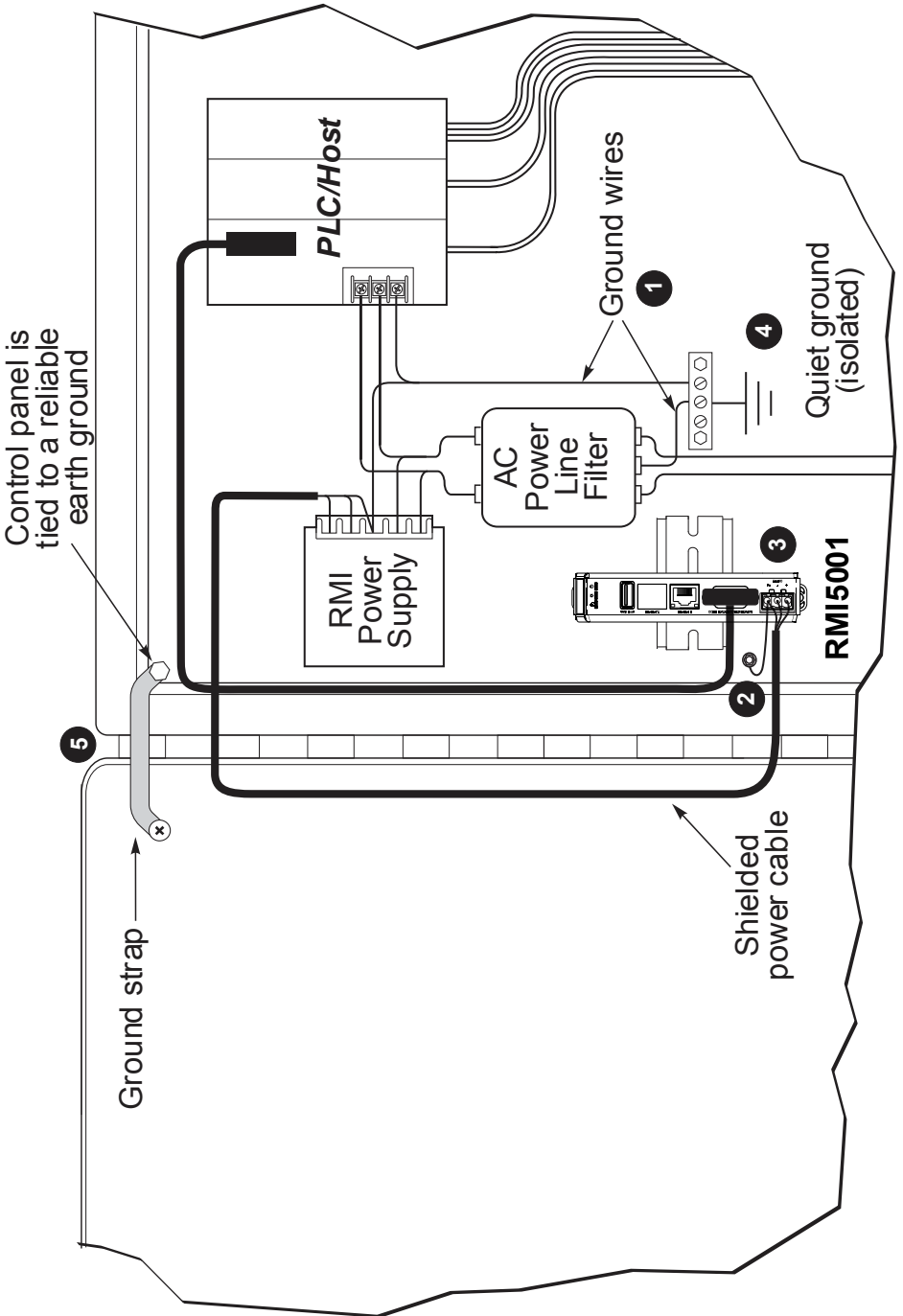

Control Panel Grounding

The control panel must be connected to a good, high-integrity earth ground both for safety considerations and shielding purposes. Maple Systems cannot overemphasize the importance of good grounding. Failure to use good grounding procedures during installation may cause sporadic malfunction of the HMI.

Connect the HMI chassis ground terminal to a reliable earth ground with a low-resistance path. Refer to Figure 1:

- ❶ Route all earth ground wires that lead from the HMI, the PLC, the power supply, and the line filter to a central earth ground point such as a barrier strip. This will ensure that no ground current from one device influences the operation of the other devices.
- ❷ Connect the HMI chassis ground terminal to the control panel using a heavy-gauge short braided cable (#14 AWG) or ground wire to minimize resistance. Then, make sure the panel is properly grounded to a clean earth ground.

***Note:** If the control panel is made of a non-conductive material, it is essential that the chassis ground terminal of the HMI is connected to a clean earth ground point located close to the panel.*

- ❸ Connect the power cable's shield wire to the HMI's chassis ground terminal.
- ❹ Connect the control panel to earth ground using a copper grounding rod close to the HMI and control panel.
- ❺ Hinged doors on control panels do not provide a long-term electrical connection to the rest of the enclosure. Corrosion develops over time and prevents good electrical contact. For this reason, a separate wire braid should be installed from the hinged control panel to the rest of the enclosure.

For a more in-depth overview of ground wiring techniques, refer to Technical Note #1027, "OIT Ground Wiring and Electrical Noise Reduction" in the Technical Notes section of the Maple Systems website.

Installation

It is necessary to follow all installation procedures described in this chapter for electrical noise immunity and CE compliance. The Maple Systems HMI is designed to connect easily to your PLC. External connectors provide quick connections for power, communications and programming wiring.

Connect the HMI to Power

Use the 3-position connector supplied with the HMI to provide power to the HMI. The power cable for the HMI should be 18AWG, 2-conductor wire with a shield drain wire and protective shield (foil/braid). Cable (P/N 6030-0009) may be purchased by the foot from Maple Systems for constructing power cables.

Always run the DC ground wire directly back to the signal return of the power supply. *Do not use the chassis ground wire as the signal return.*

⚠ Caution: *To prevent possible damage to the HMI, wait ten seconds after removing power from the HMI before applying power again.*

To connect the HMI to power:

1. Route the power cable from the HMI to the power supply. The power cable should not be any longer than necessary.
2. Install the cable wires, referencing the chart below (with colors shown for Maple Systems Cable 6030-0009):
 - a. Strip the power cable shield to expose 2" of the black and red wires.
 - b. Strip about ¼" of insulation from the black and red wires.
 - c. Connect the red wire to the positive (+) input of the HMI power connector and the 24V DC positive (+) output of the power supply.
 - d. Connect the black wire to the negative (–) input of the HMI power connector and the 24V DC negative (–) output of the power supply.
 - e. Connect the power cable shield wire to the HMI power connector FG or \equiv input. Connect the other side to chassis ground.

Wire Color	Power Supply Output	HMI Input
Red	+	+
Black	–	–
Shield	Chassis ground	FG or \equiv

Note: *The power connector on the RMI5001 uses a 3-position terminal block with screw-down clamps. Lugs are not required.*

Fusing Requirements

If the HMI does not come on within two seconds of power up, remove power. An internal solid-state fuse will prevent damage if the polarity of the DC power is incorrect. Check wiring to ensure proper connections and try to power up again.

Panel Preparation

The RMI5001 models mount directly on the enclosure's back or side panel using 35mm DIN rail, or screwed directly to the panel with user-supplied M4 or #8 panhead screws.

Mount the HMI to the Panel

Figure 2a: Installing the HMI to DIN rail

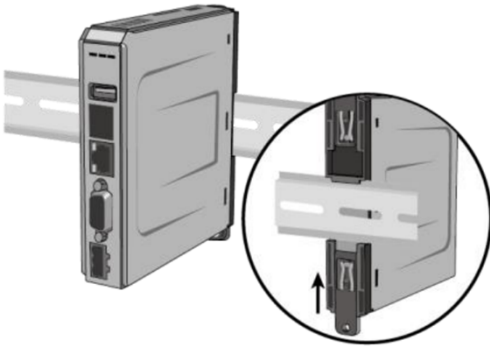

Push both tabs down, and place the unit over the DIN rail. Then slide the bottom tab up.

Figure 2b: Installing the HMI directly to the panel

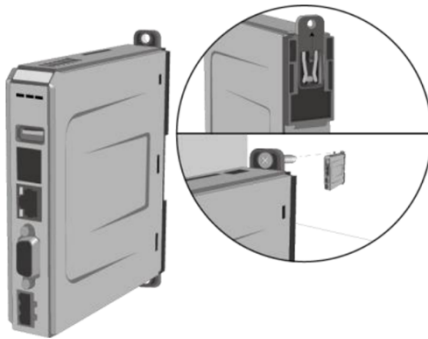

Push the top tab up and the bottom tab down to expose the mounting holes.

HDMI® Connection

A standard Type-A HDMI® socket is provided on the top of the RMI5001 series. Use the HDMI® socket to connect any video display that supports HDMI® at 1280x720 resolution.



USB/SD Port

The RMI5001 has an SD card slot and USB host port. These ports are designed for keyboard/mouse connection or data storage only.

Note: *If connecting a USB hard drive, power the drive with its own power supply. **DO NOT charge any device from the USB port.***

Initial Configuration Setup and Maintenance

The HMI will need to be configured before initial use. Use the EZwarePlus software to create a project that will be downloaded into the HMI. The HMI has a Demonstration project pre-installed.

Use the Ethernet Crossover Configuration Cable (P/N 7431-0104) if connecting the HMI directly to the development PC.

If using a switch or router between the PC and the HMI, use a straight-through or crossover cable as required by the switch or router.

Accessing IP Address of the HMI

The HMI's Ethernet port is configured as a DHCP client (Dynamic IP) by default from the factory. To download a project into the HMI, it is necessary to know the IP address of the HMI. Follow the steps below to change it:

1. Connect a High-Definition compliant video display to the HMI via HDMI® cable (or appropriate DVI/HDMI® adapter cable). Select the appropriate Digital Input mode on the display.
2. Connect a USB mouse to the HMI's USB host port.
3. Power the HMI and you will see the currently-loaded project on the display.
4. Using the mouse, enter the System Settings menu by clicking the arrow icon located at the lower-right corner of the screen.
5. Click the gear icon to open the Settings window.
6. Enter the HMI password (default password is *111111*) to enter the System Settings window.
7. Click the "Obtain IP address from Below" radio button and enter the desired IP address and Subnet Mask (Dependent upon your specific networking configuration).
8. Click "Apply" and then "OK" to save the changes.
9. Connect the HMI to the PC or network and now you can download to and configure the HMI.

DIP switch positions



DIP switches shown in the *off* position.

SW1	SW2	Mode
OFF	OFF	Normal Operation
ON	OFF	Hide System Setting Toolbar
OFF	ON	Boot Loader mode
ON	ON	Restore Factory Settings

Note: Power must be cycled on the HMI after the DIP switches are changed to activate the selected mode.

Hide System Setting Toolbar: Hides the arrow in the bottom-right corner of the screen that accesses the System Toolbar.

Boot Loader mode: This mode forces the HMI to not execute the project. This mode is used when replacing or reinstalling the operating system. Contact Maple Systems for more information.

Restore Factory Settings: Erase project data and restore factory settings such as IP settings and passwords.

Serial Port Connections

The diagram below indicates the proper pin connections for the serial ports of the RMI5001.

Figure 4: Serial Port Pinouts

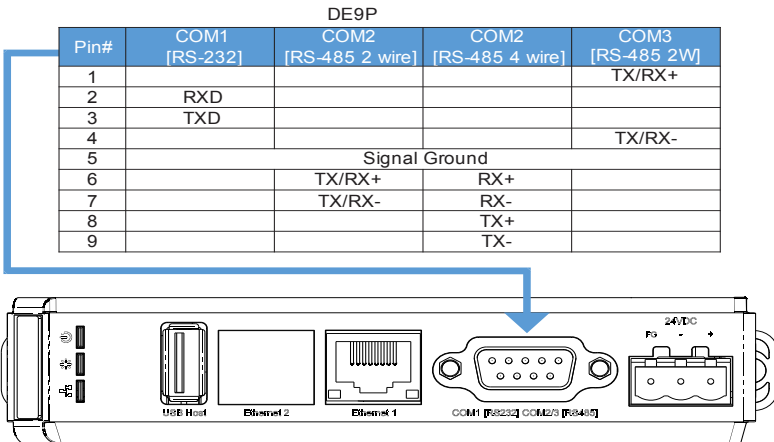

Note: COM2 [RS-485 2W] and COM3 [RS-485 2W] support the Siemens MPI 187.5K multi-point interface. However, only one COM port can be used with the Siemens MPI interface at a time.



Maple Systems Inc.
808 134th Street SW, Suite 120
Everett, WA 98204-7333
Phone: (425) 745-3229
Email: maple@maplesystems.com
Web: www.maplesystems.com

© 2018 Maple Systems Inc. All rights reserved.