

# Maple Systems Smart HMI Series

Your Experts in Automation  
Control Solutions



As a leader in operator interface products since 1983, Maple Systems looks forward to providing you with quality, affordable control solutions.

# Table of Contents

- 03: Executive Message
- 05: Company Profile
- 06: Overview: Basic Series of HMI's
- 07: Features
- 08: cMT-SVR
- 10: cMT-D090 - 9.7"
- 12: cMT5151- 15"
- 14 Support



## Message from the Executive Team

For more than three decades, Maple Systems has proudly provided solutions for the automation and industrial controls marketplace.

Maple Systems first began as a systems integrator, and in building systems for others, saw a great need for lasting and innovative control products. We entered the marketplace by creating some of the first operator interface terminals for companies requiring embedded control systems.

Since then, our focus has expanded to supplying an array of control solutions: HMIs, Panel PCs, HMI + PLC units, and more. Our goal is to enable our customers to meet their diverse set of needs by providing them with quality products and a quality customer experience.

In 2015, Maple Systems became an employee-owned company. This is an exciting time for us! Five simple pillars influence every aspect of our company:

- **Quality** in our job and the products we provide
- **Respect** for our customers and fellow owners
- **Pride** in our work and ability to meet customer needs
- **Accountability** for the results of our work
- **Attitude** of positivity and possibility

Because of this key foundation, each owner has a personal investment in providing the highest level of customer satisfaction. Many of our “new” owners have been with the company long-term, offering insight as to why quality has and will continue to endure at Maple Systems. Our employee ownership and governing management team will ensure that Maple Systems effectively supports our customers well into the future.

Our mission is to be recognized in the industrial market as the preferred supplier of industrial control and automation products. Maple Systems will continue to achieve this by implementing a philosophy of high-quality, affordable prices, and continuous improvement.

**For more than 30 years,  
our focus has been  
supplying innovative  
control solutions.**

## Executive Team



Larry St. Peter  
President and CEO



Sarah Davis  
Executive Vice  
President



Daunne O'Farrell  
Vice President of  
Finance



Andre Zins  
Vice President of  
Manufacturing



**Maple Systems, Inc.**  
**Your Industrial Control Solution.**

## Company Profile

### Maple Systems Specializes in Operator Interface Solutions

At Maple, we are committed to quality, reliability, and affordability. Our products deliver the quality you deserve, the reliability you demand, with a value that will drive your growth. Whether your customers are residential, commercial, or industrial; whether you create custom automation and integration solutions or manufacture products that require 21st century control, Maple Systems will add value and improve your user experience.

### We Make Machine Control Easy

With modern touchscreens, unrivaled value and functionality, combined with intuitive software, Maple Systems provides a versatile offering of products to complement your machine's design:

- Touchscreen HMIs
- HMI + PLC
- Remote (Smart) HMIs
- Light Industrial Panel PCs
- Heavy Industrial Panel PCs
- Text-Based Alphanumeric OITs

### Best-Value Products

Our goal is to offer high-quality control solutions at affordable prices. We strive for continuous product improvement by being experts in our field, employing the latest technologies, and ensuring that every product is fully tested and inspected before leaving our facility. Paired with an outstanding support team and comprehensive technical website, you'll see that Maple Systems truly is *your* industrial control solution.

### Contact Us Today

We invite you to explore our product offerings and contact us to discuss how Maple Systems can help solve and support your automation and control needs:

**Phone:** 425-745-3229

**Email:** [info@maplesystems.com](mailto:info@maplesystems.com)

**Web:** [www.maplesystems.com](http://www.maplesystems.com)



# Smart HMI Series



## What is cMT?

cMT = Control and Monitor

Maple's innovative Smart HMI solutions are IIoT-ready HMIs that enable easy monitoring of your industrial plant from a remote device.

Maple Smart HMI solutions make it easy to monitor/control your industrial process from remote devices such as PCs, smart phones, and tablets.

Our Smart HMI series offers two models that maximize your options when selecting the correct HMI for your system.

## Smart HMIs: HMI Control for Smart Factories

Technological advances in the fields of IT, personal electronics, and manufacturing are expanding the role of the traditional Human Machine Interface (HMI) in the automation market. Today there are many more ways in which humans can and want to interface with their machines. It is no longer just an operator physically standing in front of a machine using a touchscreen to control basic operations. HMIs must network to a central location where a plant manager can monitor operations efficiently and receive quick alerts to resolve maintenance issues. OEMs need to monitor and track their equipment remotely and respond to problems without making onsite visits. And machine operators want to be free to walk around the facility controlling their machines via tablets and smartphones.

All of the above is now possible. Maple Systems Smart HMI products are designed to meet the expanding need for new ways to connect to equipment, while still preserving the core function of a fixed operator terminal.

Install our free cMT Viewer software on your device to enable control and monitoring on any Windows PC, or Apple/Android phone or tablet.

Enjoy excellent IIoT connectivity with support for many IIoT protocols including MQTT, OPC UA Server, MySQL Database, and more.

**At Maple Systems, it's  
control and monitoring  
your way.**

Everything you need for  
smart factory **control** and  
**monitoring** today.

Explore cMT

Formerly known as RMI Series



## Features

# See the Possibilities: Maple Smart HMIs

## Everything you need for smart factory control and monitoring today.

### cMT-SVR Overview

The cMT-SVR connects to your PLC and connects wirelessly to PCs, Apple/Android tablets, and Apple/Android smart phones to provide instant access to your industrial control system.



The cMT-SVR is an HMI without a built-in display. Perfect for systems where a local visual interface is not required, this option provides all of the features of an HMI plus remote connectivity at an extremely affordable price. However, if a local display is still needed, the cMT-SVR can be paired with our 9.7" panel-mounted display (cMT-D090), or any of our Advanced HMIs to provide a traditional touchscreen interface.



### cMT-D090 Overview

The cMT-D090 boasts a 9.7" capacitive touchscreen with the ability to swipe, pinch, and zoom, making viewing historical data, trending objects and other data easier to see.

Durable tempered glass and UL, CE, RoHS, and NEMA 4 certifications ensure that unit will thrive in tough industrial environments.

### cMT5151 Overview

The cMT5151 has a large 15" resistive touchscreen display and an aluminum enclosure to easily accommodate even the most complex control systems.

The cMT5151 offers all the features and capabilities of Maple's Advanced HMIs, plus possesses a built-in cMT-SVR, making it a complete all-in-one solution.



## Smart HMI Features:

Model Number	cMT-SVR	cMT-D090	cMT5151
Display	No Display Included	9.7" 1024 x 768	15" 1024 x 768
List Price	\$270	\$725	\$1850
Max Colors	N/A	262,000	16.2 Million
Touchscreen	N/A	Capacitive	Analog Resistive
CPU	600MHz	1GHz	1GHz
Memory	256MB/ 256MB	512MB/ 1GB	4GB/ 1GB
USB	1 Host	No	1 Host, 1 Client
Ethernet	2	1	2
Serial Ports	3	No	2
CANbus	No	No	Yes
SD Card Slot	Yes	No	Yes
Video In (Analog NTSC or PAL)	No	No	Yes
Audio Out	No (Use cMT-D090 or PC)	Built-In Speaker	Yes
Enclosure	Plastic	Plastic	Aluminum
Operating Temperature	-4° ~ 131°F (-20° ~ 55°C)	32° ~ 122°F (0° ~ 50°C)	32° ~ 122°F (0° ~ 50°C)
Power Requirements	24VDC, 230mA	24VDC, 900mA	24VDC, 900mA
Dimensions (W x H x D")	5.12 x 4.53 x 1.06 inches	10.13 x 7.86 x 1.29 inches	14.41 x 11.54 x 1.9 inches
Certifications	CE, cULus	CE, cULus, RoHS	CE, cULus, RoHS
Protection	IP20	IP65 (NEMA 4X)	IP65 (NEMA 4X)
Software Features (EzWarePlus)	Yes	(Not Programmable)	Yes
CUPS Printer Drivers	No	N/A	Yes
PDF Reader	No	N/A	Yes
Barcode Scanner Using Android Tablet/Phone	Yes	N/A	Yes
VNC Server	No	N/A	Yes
Download via USB Port	No	N/A	Yes
3G/4G Dongle Support	Yes	N/A	No
MySQL Database Server	Yes	N/A	Yes
Panasonic ECO Meter Support	Yes	N/A	Yes
File Browser	No	N/A	Yes
Media Player (Videos)	No	N/A	Yes
MQTT (Publisher/Subscriber)	Yes	N/A	Yes
OPC UA Server	No	N/A	Yes
Picture (Slideshow) Viewer	No	N/A	Yes
Pie Chart	No	N/A	Yes
USB Camera (Direct)	No	N/A	Yes
USB Camera (To Remote Web Browser)	Yes	N/A	No



## Smart-Device Compatible HMI



- 256 MB Flash, 256 MB RAM Memory
- 32-bit RISC Cortex-A8, 600 MHz CPU
- 2 Ethernet, 3 Serial Ports, 1 USB Port
- Works with iPad/Android Tablet, Android Smart Phone
- Does Not Come with Display

<b>System</b>	CPU	32-bit RISC Cortex-A8, 600 MHz
	Memory (RAM)	256 MB
	Memory (Flash)	256 MB
	RTC	Built-in
<b>I/O Ports</b>	Serial Ports	1 x DE9P COM1: RS-232, COM2: RS-485 2 or 4 wire, COM3: RS-485 2 wire N/A
	Ethernet	2 x 10/100/1000 Base-T
	CANbus	N/A
	USB Host	1 x USB 2.0
	USB Client	N/A
	Audio	N/A
	Video	N/A
	Wi-Fi	N/A
	HDMI	N/A
	SD Card Slot	SD/SDHC
<b>Display</b>	Display Type	N/A
	Size (W x H)	N/A
	Resolution (pixels)	N/A
	Luminance (cd/m <sup>2</sup> )	N/A
	Contrast Ratio	N/A
	Max. Colors	N/A
	LED Backlight Longevity Hrs.	N/A
<b>Touch Screen</b>	Type	N/A
	Active Area Accuracy	N/A
<b>Electrical</b>	Input Voltage	24 ± 20% VDC
	Input Current	230 mA @ 24 VDC
	Power Isolation	Built-in
	Isolation Resistance	Exceed 50 MΩ at 500 VDC
<b>Mechanical</b>	Enclosure	Plastic, charcoal grey
	PCB Coating	Yes
	Dimensions (W x H x D)	5.12 x 4.53 x 1.06 inches [130 x 115 x 27 mm]
	Weight	0.40 lbs. [0.18 kg]
<b>Environmental</b>	Mounting	35 mm DIN rail mounting
	Operating Temperature	-4° ~ 131°F (-20° ~ 55°C)
	Storage Temperature	-4° ~ 158°F (-20° ~ 70°C)
	Relative Humidity	10% ~ 90% (non-condensing)
	Vibration Endurance	10 to 25 Hz (X, Y, Z direction, 2G, 30 minutes)
	Rating	IP20
<b>Software</b>	Certifications	cULus, CE, RoHS
		EZwarePlus (v4.00.01 or later)
<b>Notes</b>		

DS-CMTSVR Rev 00



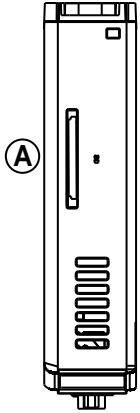

**Top View**

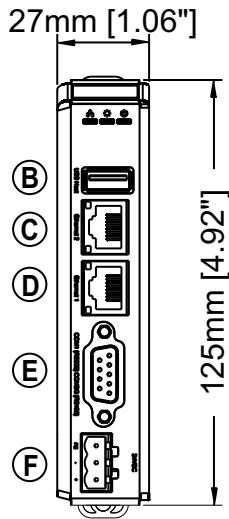

**Front View**

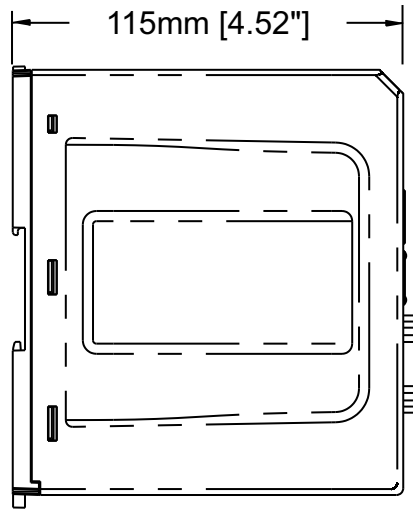

**Side View**

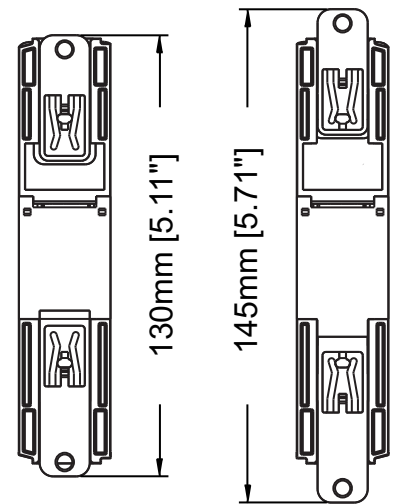

**Rear View**

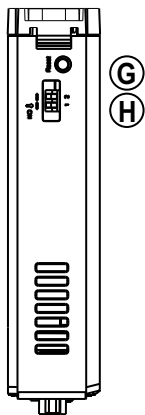

**Bottom View**

- |   |                   |   |                        |
|---|-------------------|---|------------------------|
| A | SD Card Slot      | E | DE9P Com Port 1, 2 & 3 |
| B | USB 2.0 Host Port | F | Power Plug             |
| C | Ethernet Port     | G | Reset Button           |
| D | Ethernet Port     | H | DIP Switches           |



## 9.7" Capacitive Display

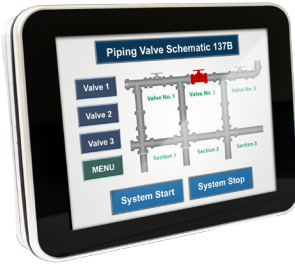

- Capacitive Touchscreen
- 1024 x 768 Resolution
- 32 Bit RISC Cortex-A9, 1 GHz CPU
- Ethernet, 2 Serial Ports
- Display Only

<b>System</b>	CPU	32-bit RISC Cortex-A9, 1 GHz
	Memory (RAM)	1 GB
	Memory (Flash)	512 MB
	RTC	Built-in
<b>I/O Ports</b>	Serial Ports	N/A N/A
	Ethernet	1 x 10/100/1000 Base-T
	CANbus	N/A
	USB Host	N/A
	USB Client	N/A
	Audio	Built-in mono speaker
	Video	N/A
	Wi-Fi	N/A
	HDMI	N/A
	SD Card Slot	N/A
	<b>Display</b>	Display Type
Size (W x H)		7.8 x 5.8 inches [197 x 148 mm]
Resolution (pixels)		1024 x 768
Luminance (cd/m <sup>2</sup> )		350
Contrast Ratio		500:1
Max. Colors		262 K
LED Backlight Longevity Hrs.		30,000+
<b>Touch Screen</b>	Type	Tempered glass, capacitive type
	Active Area Accuracy	Length (X) ±2%, width (Y) ±2%
<b>Electrical</b>	Input Voltage	24 ± 20% VDC
	Input Current	900 mA @ 24 VDC
	Power Isolation	Built-in
	Isolation Resistance	Exceed 50 MΩ at 500 VDC
<b>Mechanical</b>	Enclosure	Plastic, black and silver
	PCB Coating	Yes
	Dimensions (W x H x D)	10.13 x 7.86 x 1.29 inches [257.2 x 199.7 x 32.7 mm]
	Weight	1.68 lbs. [0.76 kg]
<b>Environmental</b>	Mounting	Panel or VESA 75 x 75 mm mounting
	Operating Temperature	32° ~ 122°F (0° ~ 50°C)
	Storage Temperature	-4° ~ 140°F (-20° ~ 60°C)
	Relative Humidity	10% ~ 90% (non-condensing)
	Vibration Endurance	10 to 25 Hz (X, Y, Z direction, 2G, 30 minutes)
	Rating	IP65 compliant front panel, NEMA 4X indoor use only
<b>Software</b>	Certifications	cULus, CE, RoHS
<b>Software</b>		cMT Viewer
<b>Notes</b>		

DS-CMTD090 Rev 00



**Top View**

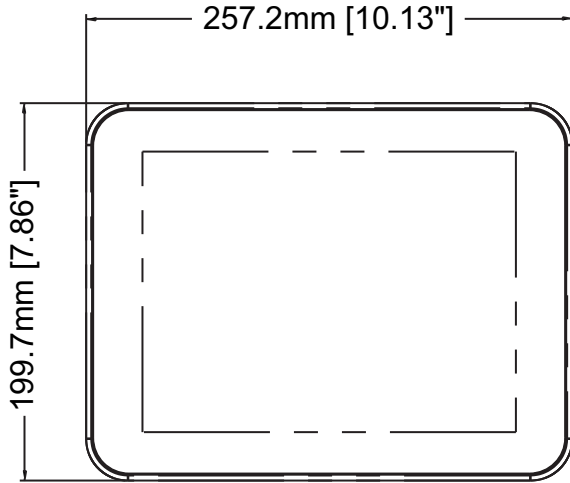

**Front View**



**Side View**

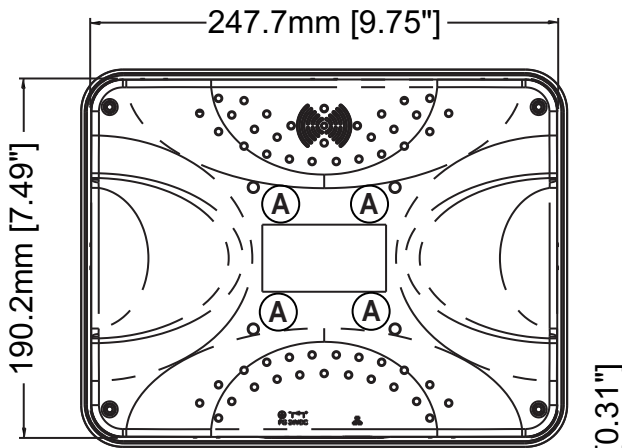

**Rear View**

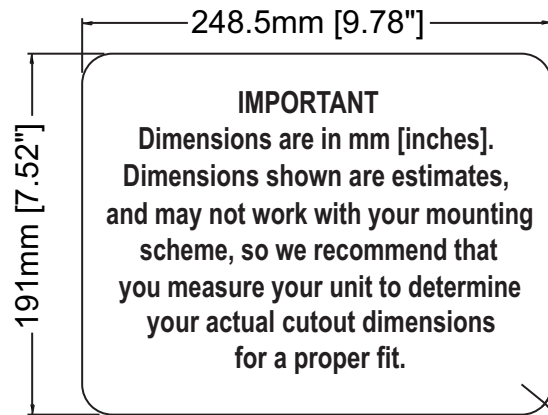

**Cutout Dimensions**

R16mm [R0.63\"]

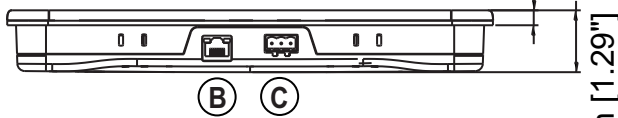

**Bottom View**

**A** VESA 75mm screw holes

**B** Ethernet Port

**C** Power Connector



## 15" cMT HMI with Built-In Server

- 1024 x 768 Pixel Resolution
- 32-Bit RISC Cortex-A9 1GHz CPU
- 2 Ethernet Ports, 2 Serial Ports, CANbus
- Aluminum Enclosure
- EasyAccess 2.0 Installed

<b>System</b>	CPU	32-bit RISC Cortex-A9, 1 GHz
	Memory (RAM)	1 GB
	Memory (Flash)	4 GB
	RTC	Built-in
<b>I/O Ports</b>	Serial Ports	1 x DE9P COM1: RS-232, COM3: RS-232* 1 x DE9S COM1: RS-485 2 or 4 wire, COM3: RS-485 2 wire
	Ethernet	1 x 10/100 Base-T, 1 x 10/100/1000 Base-T
	CANbus	Yes
	USB Host	1 x USB 2.0
	USB Client	1 x micro USB 2.0
	Audio	1 x audio line out – 3.5 mm and built-in mono speaker
	Video	2 x NTSC/PAL RCA
	Wi-Fi	N/A
	HDMI	N/A
	SD Card Slot	SD/SDHC
<b>Display</b>	Display Type	15" TFT LCD
	Size (W x H)	12.00 x 9.06 inches [305 x 230 mm]
	Resolution (pixels)	1024 x 768
	Luminance (cd/m <sup>2</sup> )	400
	Contrast Ratio	700:1
	Max. Colors	16.2 M
	LED Backlight Longevity Hrs.	50,000+
<b>Touch Screen</b>	Type	4-wire resistive touch
	Active Area Accuracy	Length (X) ±2%, width (Y) ±2%
<b>Electrical</b>	Input Voltage	24 ± 20% VDC
	Input Current	900 mA @ 24 VDC
	Power Isolation	Built-in
	Isolation Resistance	Exceed 50 MΩ at 500 VDC
<b>Mechanical</b>	Enclosure	Aluminum
	PCB Coating	Yes
	Dimensions (W x H x D)	14.41 x 11.54 x 1.9 inches [366 x 293 x 48.2 mm]
	Weight	5.4 lbs. [2.45 kg]
	Mounting	Panel or VESA 75 x 75 mm mounting
<b>Environmental</b>	Operating Temperature	32° ~ 122°F (0° ~ 50°C)
	Storage Temperature	-4° ~ 158°F (-20° ~ 70°C)
	Relative Humidity	10% ~ 90% (non-condensing)
	Vibration Endurance	10 to 25 Hz (X, Y, Z direction, 2G, 30 minutes)
	Rating	IP65 compliant front panel, NEMA 4X indoor use only
	Certifications	cULus, CE, RoHS
<b>Software</b>	EZwarePlus (v4.00.01 or later) EasyAccess 2.0 pre-installed and activated	
<b>Notes</b>	*Only Tx and Rx may be used for COM1 RS-232 while COM3 RS-232 is in use.	

DS-CMT5151 Rev 00

Top View

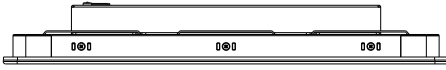

Front View

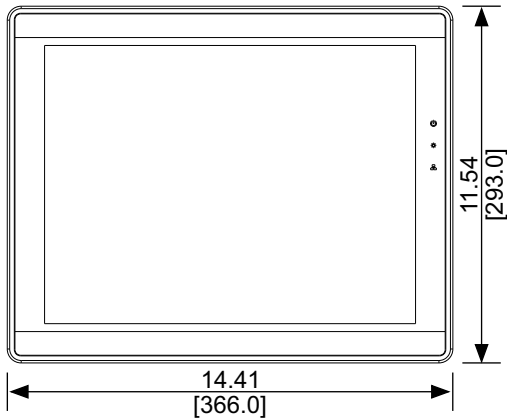

Side View

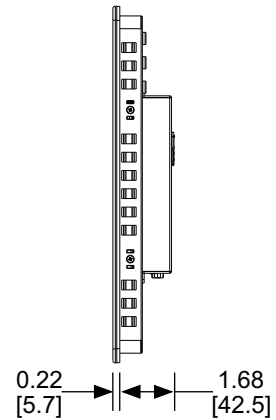

Rear View

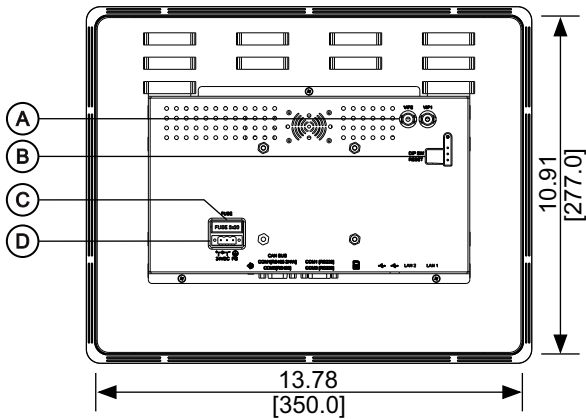

Cutout Dimensions

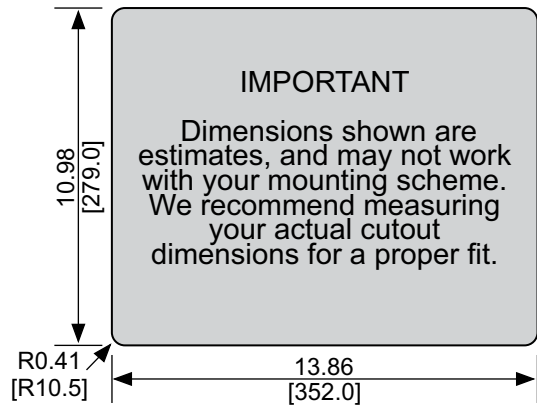

Bottom View

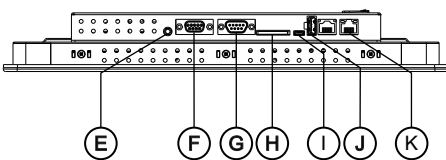

Dimensions are in inches [mm]

- Ⓐ Video input 1 & 2      Ⓑ DIP switches & reset      Ⓒ Fuse      Ⓓ Power connector
- Ⓔ Line out      Ⓕ COM port DE9S      Ⓖ COM port DE9P      Ⓗ SD card slot
- Ⓘ Mini USB 2.0 port      Ⓖ USB 2.0 host port      Ⓚ Ethernet port

# SUPPORT



## Overview

Maple Systems delivers the industry's best value in control products. For us, "best value" means high-quality products and outstanding service at a great price.

In addition, all products are backed by an outstanding team and complimentary technical support. How can we help meet *your* control needs?

## Support The Maple Standard

Maple Systems is honored to be recognized as a leader in the industrial controls marketplace. The Maple Standard represents our dedication to delivering high-quality control products and support to our valued customers. It is our promise to deliver quality, reliability, and value to help you achieve your business and process goals. We'll assist you every step of the way so you can get the job done on time and within budget.

### We Make Partnerships Easy

At Maple Systems, our team strives to make doing business with us easy. We want you achieve a positive and enjoyable experience every time you use our products or services. When partnering with Maple Systems, know that our high-quality, competitively-priced products are backed by a dedicated team of professionals ready to assist you. We also lead our industry with:

- Over 30 years of industry experience
- Rugged products that are built-to-last
- A team dedicated to providing complimentary support

**For us, "best value" means providing high-quality control products and outstanding service at a great price.**

### The Maple Promise

Since 1983, Maple Systems has been a global leader in the operator interface industry.

Our goal is to offer you high-quality control solutions at affordable prices.



# Support

## Quality Products & Customer Service

**The Maple Standard represents our promise to deliver quality, reliability, and value to help you achieve your business and process goals.**

### PLC Integration

Maple Systems products integrate with more than 300 programmable controllers from the biggest names in PLCs including Allen Bradley, Schneider Electric, GE, Siemens, Mitsubishi, and Omron.



Communicate with PLCs, motion controllers, temperature controllers, embedded microcontrollers, and more.

### Intuitive Configuration Software

Our configuration software is easy-to-use and offers great functionality. Enjoy alarm management, data logging, trending, batch recipes, and more. Experience greater functionality at a fraction of the cost compared to other industry models.

### Comprehensive Website and Support Center

Our website's online support center provides customers with 24-hour answers to complex control automation needs. Explore tech notes, product specifications, sample projects, drivers, and software upgrades. We also offer complimentary technical support to our customers via email and phone. Visit us at [www.maplesystems.com/support](http://www.maplesystems.com/support).



### Industry Accolades

Maple Systems has received many favorable product reviews, readership, and editor awards from customers, media, and trade publications.



Our products have been featured in articles from major trade publications including Control Design, Control Engineering, and Packaging World. Maple Systems was also named one of America's fastest growing private companies for six years by Inc. 5000 Magazine.

### IIoT Ready

Maple Systems interfaces are IIoT-ready with support of close to 300 different communication protocols including MQTT, Profinet, and Ethernet IP. Maple Systems solutions can ensure an OEM's machines will be IIoT-ready today, when customers request this functionality today, tomorrow, and well into the future. With IIoT-ready products in a range of size and features, Maple Systems has the flexibility to meet a variety of needs.



### Reliability You Can Trust

At Maple Systems, we want every customer to be a lifelong customer. This commitment has helped us consistently offer great value and support to customers at affordable prices.

We hope you will be a part of our future as we continue to lead and innovate the industrial controls marketplace. After all, the most important ingredient in "The Maple Standard" is you.

### Contact Us

How can Maple Systems help meet *your* control needs? Contact our control automation experts today.

**Phone: 425.745.3229**

**Email: [info@maplesystems.com](mailto:info@maplesystems.com)**

**Website: [www.maplesystems.com](http://www.maplesystems.com)**



**Control  
Solutions for  
Every Industry**



Maple Systems  
808 134th St. SW, Suite 120  
Everett, WA 98204

## Your Industrial Control Solutions Source

[www.maplesystems.com](http://www.maplesystems.com)



AW-0910-0029 Rev 00