

DINergy™ MDP50 “CS” SERIES



AC - DC DIN RAIL MOUNTABLE POWER SUPPLY
INDUSTRIAL CONTROL EQUIPMENT

FEATURES

- UNIVERSAL INPUT 85~264VAC
- SHORT CIRCUIT PROTECTION
- INTERNAL INPUT FILTER
- HIGH EFFICIENCY UP TO 87%
- HIGH AVERAGE EFFICIENCY MEET ErP
- LOW STANDBY POWER CONSUMPTION
- 3 YEARS WARRANTY



MODEL LIST

MODEL NO.	INPUT VOLTAGE	OUTPUT WATTAGE	OUTPUT VOLTAGE	OUTPUT CURRENT	EFF. (min.)	EFF. (typ.)	EFF. (avg.)
Single Output Models							
MDP50-12A-1CS	85~264 VAC	48 WATTS	+ 12 VDC	4 A			FUTURE
MDP50-24A-1CS	85~264 VAC	50 WATTS	+ 24 VDC	2.1 A	85%	87%	87%

SPECIFICATION

All Specifications Typical At Nominal Line, Full Load, 25°C Unless Otherwise Noticed

GENERAL						
Characteristics	Conditions	min.	typ.	max.	unit	
Switching frequency	Vi nom, Io nom		65		KHz	
Isolation voltage	Input-Output	3,000 / 4,242			VAC / VDC	
	Input-FG	1,500 / 2,121			VAC / VDC	
	Output-FG	500 / 710			VAC / VDC	
	Input-Output, @ 500VDC	100			MΩ	
Ambient temperature	Operating at Vi nom	-25		+ 71	°C	
Derating (see derating curve)	Vi nom, from +51°C to +71°C			2.5	% / °C	
Storage temperature	Non operational	-40		+ 85	°C	
Relative humidity	Vi nom, Io nom	20		95	% RH	
Temperature coefficient	Vi nom, Io min			± 0.03	% / °C	
MTBF	Bellcore Issue 6 @40°C, GB	5V		532,000	Hours	
		12V		556,000	Hours	
		24V		580,000	Hours	
Altitude during operation	EN 60950-1			5,000	m	
Dimension	Spring & Screw terminal type	L90 x W30 x D100			mm	
Cooling	Free air convection					
Installation position	Vertical (other direction may derating using)					
Pollution degree					2	

DINergy™ MDP50 “CS” SERIES

SPECIFICATION

All Specifications Typical At Nominal Line, Full Load, 25°C Unless Otherwise Noticed

INPUT SPECIFICATIONS

Characteristics	Conditions		min.	typ.	max.	unit
Rated input voltage	Io nom		100		240	VAC
Absolute input max. range	Ta min ... Ta max, Io nom	AC in	85		264	VAC
		DC in	120		375	VDC
Input current	Vi : 115 / 230 VAC, Io nom			1000 / 500		mA
Rated input current	Vi : 85 VAC, Io nom				1300	mA
Line frequency	Vi nom, Io nom		47		63	Hz
Inrush current	Vi : 115 / 230 VAC, Io nom				30 / 60	A
Power dissipation	Vi : 230 VAC, Io nom	5V		8.2		W
		12V		8.0		W
		24V		8.8		W
Leakage current	Input-Output				0.25	mA
	Input-FG				3.5	mA
Standby power consumption	Vi nom, Io = 0A				0.3	W

OUTPUT SPECIFICATIONS

Characteristics	Conditions		min.	typ.	max.	unit
Output voltage accuracy (Adjusted before shipment)	Vi nom, Io max		0		+ 1	%
Minimum load	Vi nom		0			%
Line regulation	Io nom, Vi min ... Vi max				± 1	%
Load regulation	Vi nom, Io min ... Io nom				± 1	%
Voltage trim range	Vi nom, 0.8 Io nom	5V	4.5		5.5	V
		12V	11.4		15.6	V
		24V	22.5		28.5	V
Rated continuous loading	Vi nom	5V	7 A @ 5Vdc / 6.3 A @ 5.5 Vdc			
		12V	4 A @ 12Vdc / 3.2 A @ 15 Vdc			
		24V	2.1 A @ 24Vdc / 1.7 A @ 28.5 Vdc			
Hold up time	Vi : 115 / 230 VAC, Io nom		20 / 50			ms
Turn on time	Vi nom, Io nom				1,000	ms
	Vi nom, Io nom → with 3500 μF CAP				1,500	ms
Rise time	Vi nom, Io nom				150	ms
	Vi nom, Io nom → with 3500 μF CAP				500	ms
Fall time	Vi nom, Io nom				150	ms
Transient recovery time	Vi nom, I ~ 0.5 Io nom				2	ms
Ripple & noise	Vi nom, Io nom, BW = 20MHz				100	mV
Power back immunity	Vi nom, Io nom 1 second	5V	7.5			VDC
		12V	22			VDC
		24V	35			VDC
Capacitor load	Vi nom, Io nom				3,500	μF
DC ON indicator threshold at start up (Green LED)	Vi nom, Io nom	5V	4.0		4.5	VDC
		12V	9.6		10.8	VDC
		24V	19.2		21.6	VDC
Efficiency	Vi nom, Io nom, Po / Pi		Up to 87%, See model list and typ efficiency curve			

CONTROL AND PROTECTION

Characteristics	Conditions		min.	typ.	max.	unit
Input fuse			T2A / 250VAC internal			
Internal surge voltage protection	IEC 61000-4-5		Varistor			
Rated over load protection	Vi nom (see typ current limited curve)		150			%
Over voltage protection	Vi nom, 0.8 Io nom (Auto Recovery)	5V	6.5		8.5	VDC
		12V	16.2		18	VDC
		24V	28.8		32.4	VDC
Output short circuit			Hiccup mode			
Degree of protection			IP20			

DINergy™ MDP50 “CS” SERIES

SPECIFICATION

All Specifications Typical At Nominal Line, Full Load, 25°C Unless Otherwise Noticed

APPROVALS AND STANDARDS

UL / cUL	UL 508 Listed
cTUVus	UL 60950-1
CE	EN 61000-6-3, EN 55022 Class B, EN 61000-3-2, EN 61000-3-3 EN 61000-6-2, EN 55024, EN 61000-4-2 Level 4, EN 61000-4-3 Level 3 EN 61000-4-4 Level 4, EN 61000-4-5 L-N Level 3, L / N-FG Level 4 EN 61000-4-6 Level 3, EN 61000-4-8 Level 4, EN 61000-4-11 ENV 50204 Level 2, EN 61204-3
Vibration resistance	meet IEC 60068-2-6 (Mounting on rail: 10-500 Hz, 2G, along X, Y, Z each Axis, 60 min for each Axis)
Shock resistance	meet IEC 60068-2-27 (15G, 11ms, 3 Axis, 6 Faces, 3 times for each Face)

PHYSICAL CHARACTERISTICS

Case size	90 x 30 x 100 mm (3.6 x 1.59 x 3.94 inches)
Case material	Plastic
Weight	200 g
Packing	0.22 kg ; 48 pcs / 12 kg / 2.16 CUFT

MECHANISM & PIN CONFIGURATION

mm [inch]

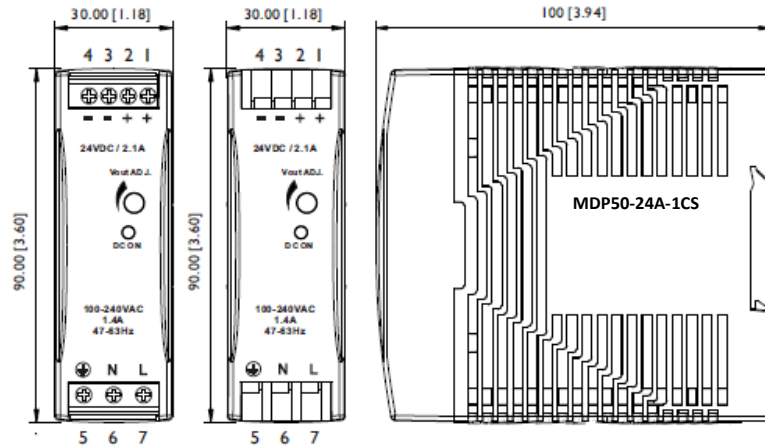

CONSTRUCTION

Easy snap-on mounting onto the DIN-Rail (TS35/7.5 or TS35/15), unit sits safely and firmly on the rail.

INSTALLATION

Ventilation / Cooling
Normal convection
All sides 25mm free space
For cooling recommended
Connector size range
Spring terminal:
AWG24-14 (0.2~2mm²) flexible / solid cable,
10 m/m stripping at cable end recommends
Screw terminal:
AWG26-12 (0.2~2.5mm²) flexible / solid cable,
connector can withstand torque at maximum 5
pound-inches.
4-5 m/m stripping at cable end recommends
Use copper conductors only, 60 / 75°C

GENERAL TOLERANCE

0.00[0.00] - 30.00[1.18]	±0.30[0.01]
30.00[1.18] - 120.00[4.72]	±0.50[0.02]

PIN ASSIGNMENT

PIN NO.		Designation	Description
1, 2	OUT	V +	Positive output terminal
3, 4		V -	Negative output terminal
5	IN	⊕	Ground this terminal to minimize high-frequency emissions
6		N	Input terminals (neutral conductor, no polarity at DC input)
7		L	Input terminals (phase conductor, no polarity at DC input)
	OTHER	Vout ADJ.	Trimmer-potentiometer for Vout adjustment
		DC ON	Operation indicator LED

DINergy™ MDP50 “CS” SERIES

CIRCUIT SCHEMATIC

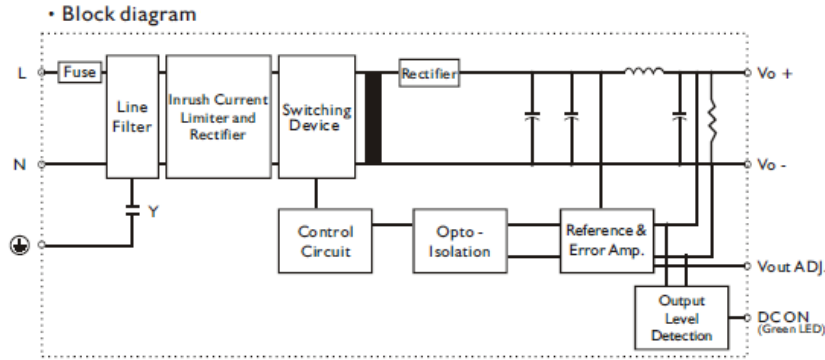

TYP. CURRENT LIMITED CURVE

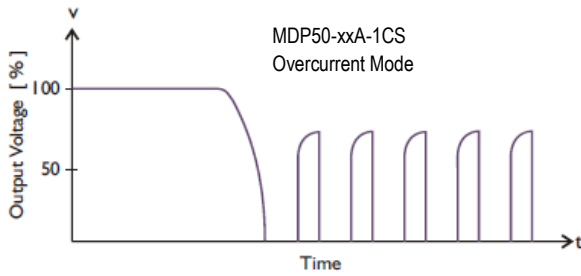

DERATING CURVE

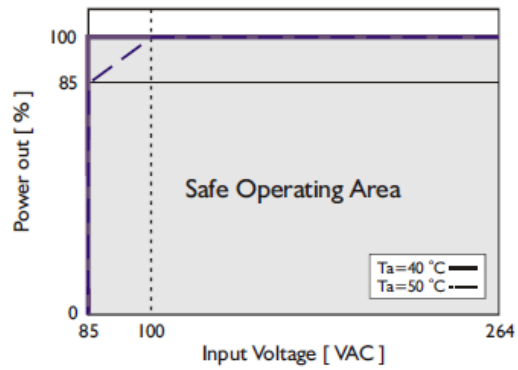
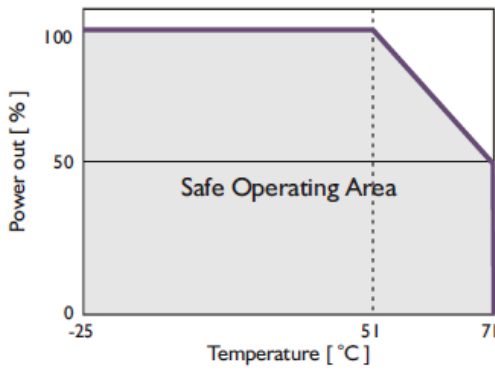

TYP. EFFICIENCY CURVE

MDP50-24A-1CS

