

ENG. FILE NAME: FIGURE\44\FUSEBLCK\REJCT\RJP-KJ

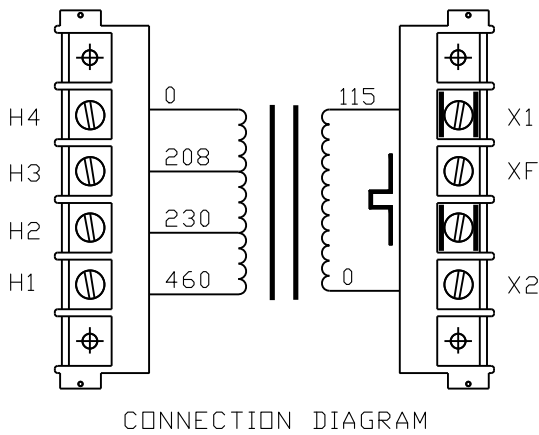

RATING: 2000VA 50/60HZ  
 PRI. 208/230/460V  
 SEC. 115 VOLTS  
 TEMP.CLASS 180

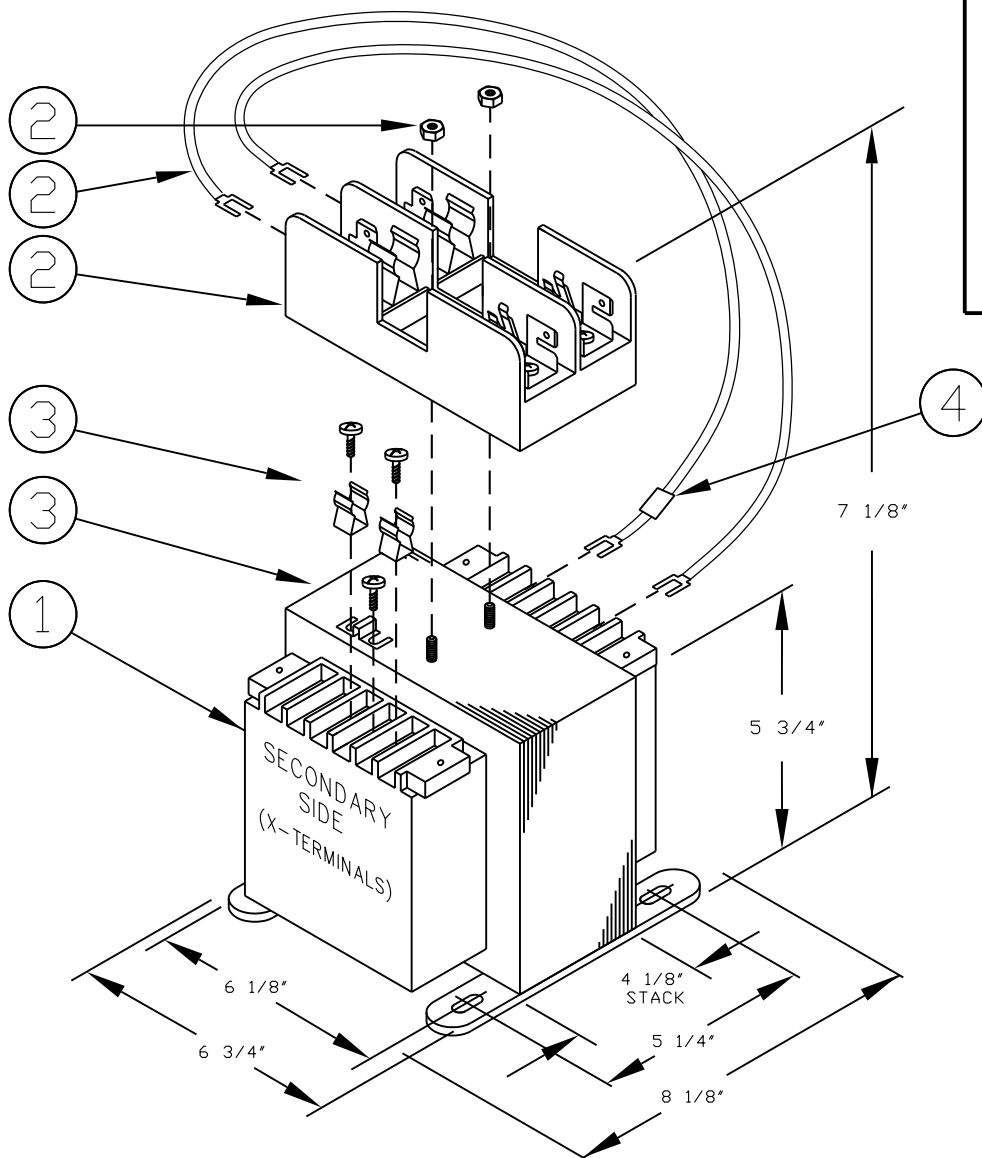

B2K0MBT13RKH

Assembly instructions: \_\_\_\_\_

- c INSTALL FUSE BLOCK PER 361-0120
- b INSTALL FUSE CLIPS PER 361-0100
- a APPLY LABELS PER 361-0005

ASSEMBLY Instructions

FOR TEST REQUIREMENTS SEE COIL TEST PAGE: 419-0070

TREATMENT:  
 IMPERV     VALU     ECON     GLOBAL  
 VACUUM IMPREGNANT, TYPE \_\_\_\_\_  
 OTHER \_\_\_\_\_

- 8
- 7
- 6
- 5
- 4 LEAD MARKER "H"
- 3 TYPE "K" FUSE CLIPS W/JUMPER
- 2 REJECTION FUSEHOLDER KIT
- 1 BASE MODEL/COIL 619-0070/419-0070
- IT ITEM DESCRIPTION

See BILL OF MATERIAL for ITEM  
 Quantity and Part Number

**MICRON** CONTROL TRANSFORMER  
 MICRON INDUSTRIES CORPORATION  
 1211 W.22nd STREET, Suite 200, OAK BROOK, ILL.  
 Tel. (800)664-4660, (630)516-1222 Fax (630)516-1820  
 www.MicronPower.com

DATE 7/27/06 DRAWN J.G.V CHECKED APPROVED

RELEASE DATE CUSTOMER PART NO.

DRAWING NAME FINAL ASSEMBLY

SIZE A SCALE NONE B2K0MBT13RKH

DRAWING UPDATED J.V 8/19/13

A NEW J.V 7/27/06

ECL REVISIONS BY DATE