

# DINergy™ MDP-PDMA-C Series

20A DIN RAIL MOUNTABLE  
REDUNDANT MODULE



## FEATURES

- SUITABLE FOR REDUNDANT OPERATION OF 24V SYSTEM MAX 20A
- READY RELAY CONTACTS
- DECOUPLING DIODES
- LED INDICATOR FOR INPUT FAILURE ALARM
- 3 YEARS WARRANTY



## SPECIFICATION

### GENERAL

Characteristics	Conditions	min.	typ.	max.	unit
Isolation voltage	Input / Relay contact	100			VDC
Isolation resistance	Input / Relay contact, @ 100VDC	100			MΩ
Ambient temperature	Operating at Vi nom	-40		+ 71	°C
Storage temperature	Non operational	-40		+ 85	°C
Relative humidity	Vi nom, Io nom	20		95	% RH
MTBF	Bellcore Issue 6 @40°C, GB		659000		Hours
Altitude during operation	IEC 60068-2-13			4850	m
Dimension		L90 x W54 x D114			mm
Cooling	Free air convection				
Pollution degree			2		

### INPUT SPECIFICATIONS

Characteristics	Conditions	min.	typ.	max.	unit
Rated input voltage	Io nom	21		28	VDC
Number of inputs			2		
Input current (max)				20	A

### OUTPUT SPECIFICATIONS

Characteristics	Conditions	min.	typ.	max.	unit
Output voltage drop	Vi n - Vout		0.5		V
Output current	Vi nom			20	A
Output peak current	Vi nom for 5ms			30	A
Reverse voltage (max)				30	V
DC ON indicator	Two LEDs indicating each input is ok	Green LED			

### CONTROL FUNCTION

Characteristics	Conditions	min.	typ.	max.	unit
Power Rdy	OK	When input is >20V(±5%) or <30V(±5%)			
	Fail	When input is <20V(±5%) or >30V(±5%)			
	Contact rating at 30VDC			1.0	A

# DINergy™ MDP-PDMA-C Series

## SPECIFICATION

APPROVALS AND STANDARDS	
UL / cJUL	UL 508 Listed UL 60950-1 Recognized
CE	EN 55022 Class B, EN 55024 EN 61000-4-2, EN 61000-4-3, EN 61000-4-4, EN 61000-4-6, EN 61000-4-8 EN 61204-3
Vibration resistance	meet IEC 60068-2-6 (Mounting by rail : 10-500 Hz, 2G, along X, Y, Z each Axis, 60 min for each Axis )
Shock resistance	meet IEC 60068-2-27 (15G, 11ms, 3 Axis, 6 Faces, 3 times for each Face)

## PHYSICAL CHARACTERISTICS

Screw terminal type	90 x 54 x 114 mm (3.6 x 2.13 x 4.49 inches)
Case material	Plastic
Weight	210g
Packing	0.28kg ; 32pcs / 10kg / 1.85CUFT

## MECHANISM & PIN CONFIGURATION

mm [inch]

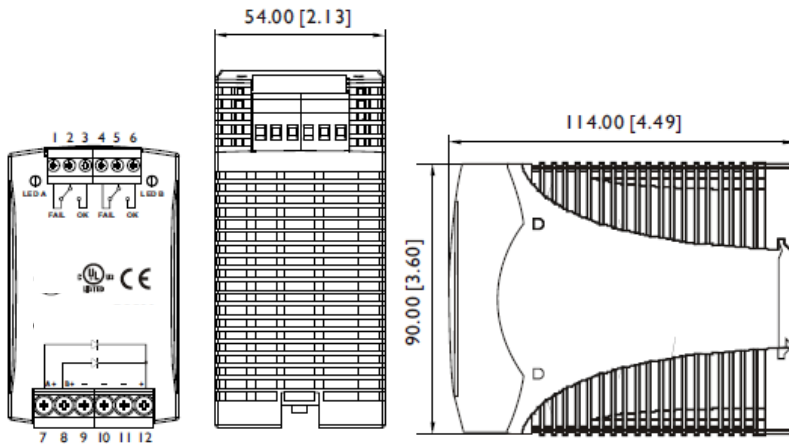

### CONSTRUCTION

Easy snap-on mounting onto the DIN-Rail (TS35/7.5 or TS35/15), unit sits safely and firmly on the rail.

### INSTALLATION

Ventilation / Cooling  
Normal convection  
All sides 25mm free space  
For cooling recommended  
Connector size range  
IN / OUT : AWG24-10 (0.2~4mm<sup>2</sup>) flexible / solid cable, connector can withstand torque at maximum 5.5 pound-inches.  
Relay : AWG24-12 (0.2~2.5mm<sup>2</sup>) flexible / solid cable, connector can withstand torque at maximum 6 pound-inches.  
7~8 m/m stripping at cable end recommends  
Use copper conductors only, 60 / 75°C

### GENERAL TOLERANCE

0.00[0.00] - 30.00[1.18]	±0.30[0.01]
30.00[1.18] - 120.00[4.72]	±0.50[0.02]

## PIN ASSIGNMENT

PIN NO.		Designation	Description
1	OUT	FAIL	A normal open relay contact for DC ON level control
2		RDY A	
3		COM A	
4		O.K	
5		RDY B	
6		COM B	
7	IN	+	Input terminal
8		+	
9	OUT	-	Negative output terminal / input terminal
10		-	
11		-	
12	OUT	+	Positive output terminal

## TYPICAL APPLICATION NOTES

1.) I + I Redundancy : Using I more PS as the redundant unit.

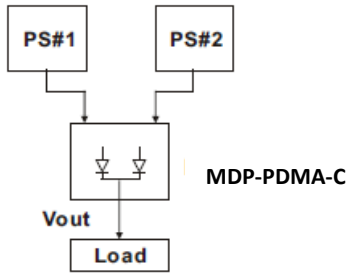

2.) Single Use : Connecting an MDP-PDMA-C to each power supply.

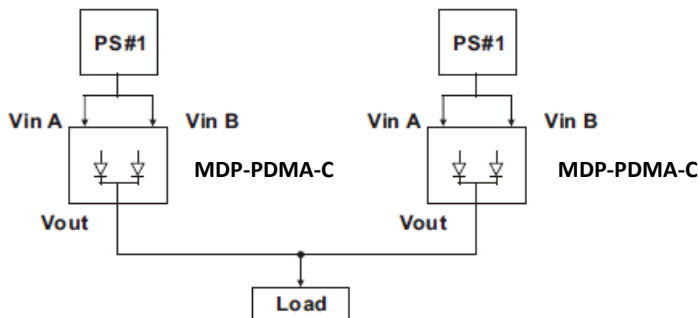

3.) I + N Redundancy : Using I more PS as the redundant units to increase the reliability.

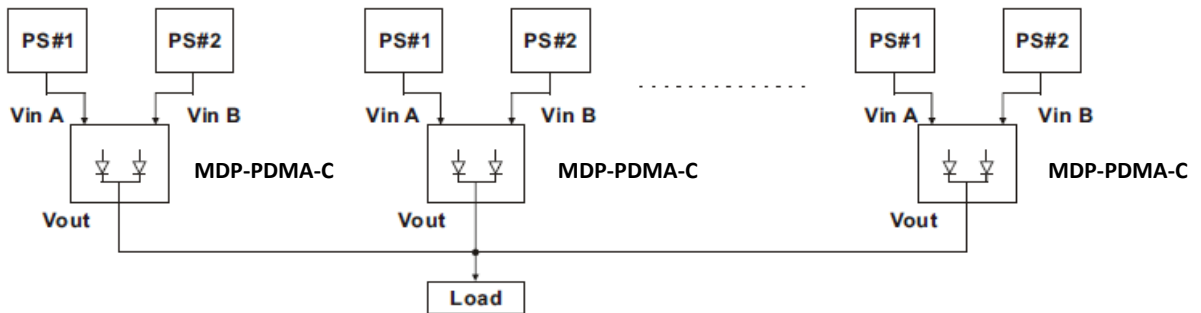

## CIRCUIT SCHEMATIC

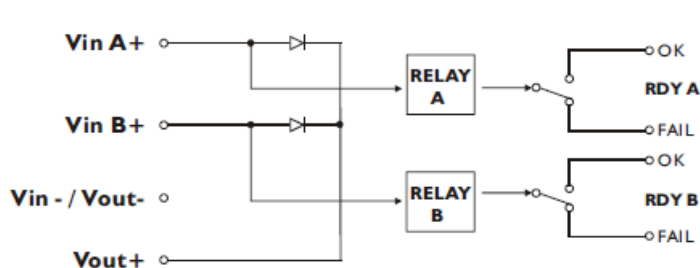

The contact rating for the signal control circuit connections is 3A/120Vac / 30Vdc.