

HLD60 with External Rail Specifications

Parameter	Value					Units
Configuration & Physical Parameters						
Motor	Animatics Size 23 Motors					-
Coupling	Flexible Jaw					-
Displacement/rev	2.5, 5, 10, 12.5					mm/rev
Position sensors	Optional Home & EOT limits					-
Stroke	100-600mm in 50mm steps 600-1000mm in 100mm steps 1000-2800mm in 200mm steps Custom lengths are available					mm
Overall length (L)	Stroke + 332					mm
Over-travel	25					mm
Unit mass	2.73 + 0.00441 x (stroke, mm) + (motor mass, kg)					kg
Performance						
Unidirectional repeatability	<20					µm
Bi-directional repeatability	60-180 (belt tension dependent)					µm
Accuracy *	0.5 per 300 stroke					mm/ mm
Displacement/rev	2.5	5	10	12.5		mm/rev
Linear speed @ 4200RPM	175	350	700	875		mm/s
Payload Mass**	45	42	18	13		kg
Continuous Thrust (Fa)						
SM2315D @ 48V @ 4500RPM	115	40	-	-		N
SM2315DT @ 48V @ 3300RPM	450	245	100	70		N
SM23165D @ 48V @ 4500RPM	270	120	35	-		N
SM23165DT @ 48V @ 3800RPM	450	420	185	135		N
SM23375D @ 48V @ 4500RPM	175	70	10	-		N
SM23375DT @ 48V @ 3200 RPM	450	290	125	90		N
Load Rating, Dynamic ** (Static)						
Fb	730 (1200)	580 (1200)	460 (1200)	430 (1200)		N
Fc	730 (1200)	580 (1200)	460 (1200)	430 (1200)		N
Carriage moments, Dynamic ** (Static)						
M.a	19 (24)	15 (24)	12 (24)	11 (24)		Nm
M.b	72 (200)	57 (200)	45 (200)	42 (200)		Nm
M.c	72 (150)	57 (150)	45 (150)	42 (150)		Nm

*Consult factory if greater accuracy is required

**Based on a 15000HR service life

@ 75/150/300 & 375mm/s (1800 RPM) average speed at given payload
Subject to routine lubrication

All OEM Dynamics™ Linear Integrated Systems are covered by Animatics patent #5,912,541 and other patents are in progress worldwide

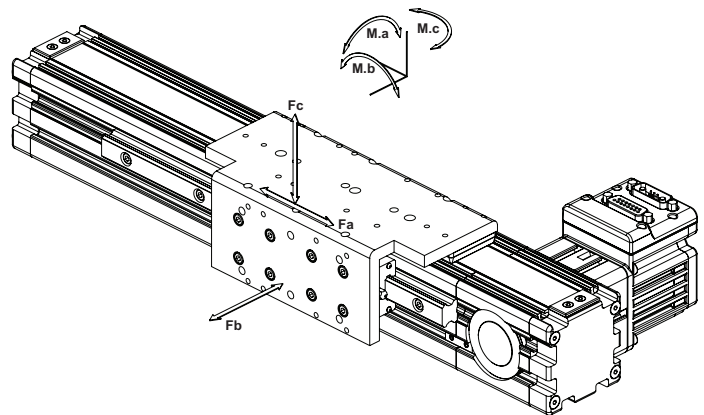

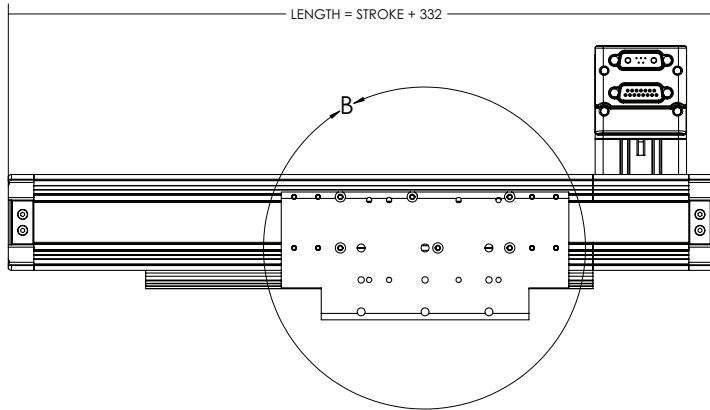

TOP VIEW

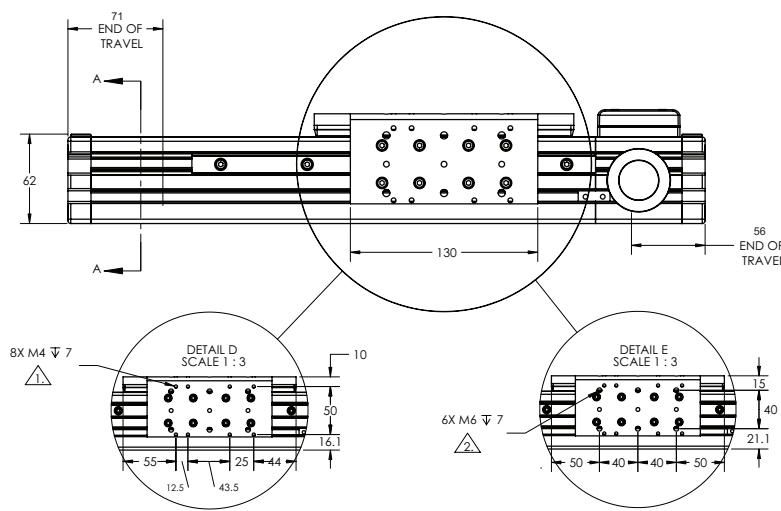
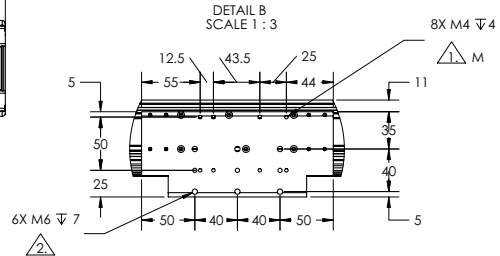

RIGHT SIDE VIEW

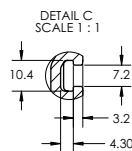
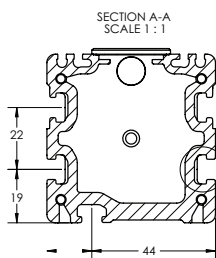

SIMPLE END VIEW

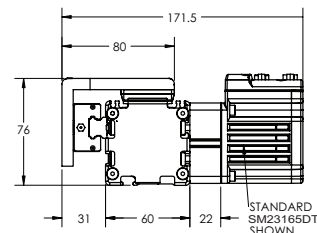

MOTOR END VIEW

NOTES:

- 1. M4 x 50 x 12.5 and M4 x 25 x 50 for mounting L70 actuator.
- 2. M6 x 40 x 40 standard bolt pattern for optional mounting accessories.

Dimensions in millimeters

Note: For part numbers please refer to our Website at www.oemdynamics.com

Thrust Curve performance data in following section on pages 109-126.