

OVERVIEW

MOTOR SPECIFICATIONS

LINEAR SYSTEMS

CONNECTIVITY

PERIPHERALS

IP 65 MODELS & CONNECTIVITY

POWER SUPPLIES & SHUNTS

GEAR HEADS

SOFTWARE

APPENDIX

SM23305D		
Continuous Torque	3.98	in-lb
	64	oz-in
	0.45	N-m
Peak Torque	6.86	in-lb
	110	oz-in
	0.77	N-m
Nominal Continuous Power	220	Watt
No Load Speed	5,600	RPM
Continuous Current @ Nominal Power	6.8	Amps
Voltage Constant	9.32	V/kRPM
Winding Resistance	1.2	ohms
Encoder Resolution	4,000	Counts/Rev
Rotor Inertia	0.00273	oz-in-sec <sup>2</sup>
	1.928	10 <sup>-6</sup> Kg-m <sup>2</sup>
Weight	2.3	lb
	1.03	kg
Shaft Diameter	0.250	in
	6.35	mm
Shaft, Radial Load	7	lb
	3.18	kg
Shaft, Axial Thrust Load	3	lb
	1.36	kg
DeviceNet Available	Yes	
Profibus Available		
CANopen Available	Yes	

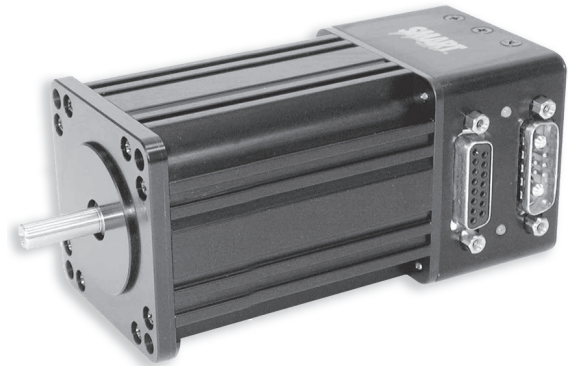

## Animatics SmartMotor SM23305D (No Options) CAD Drawing

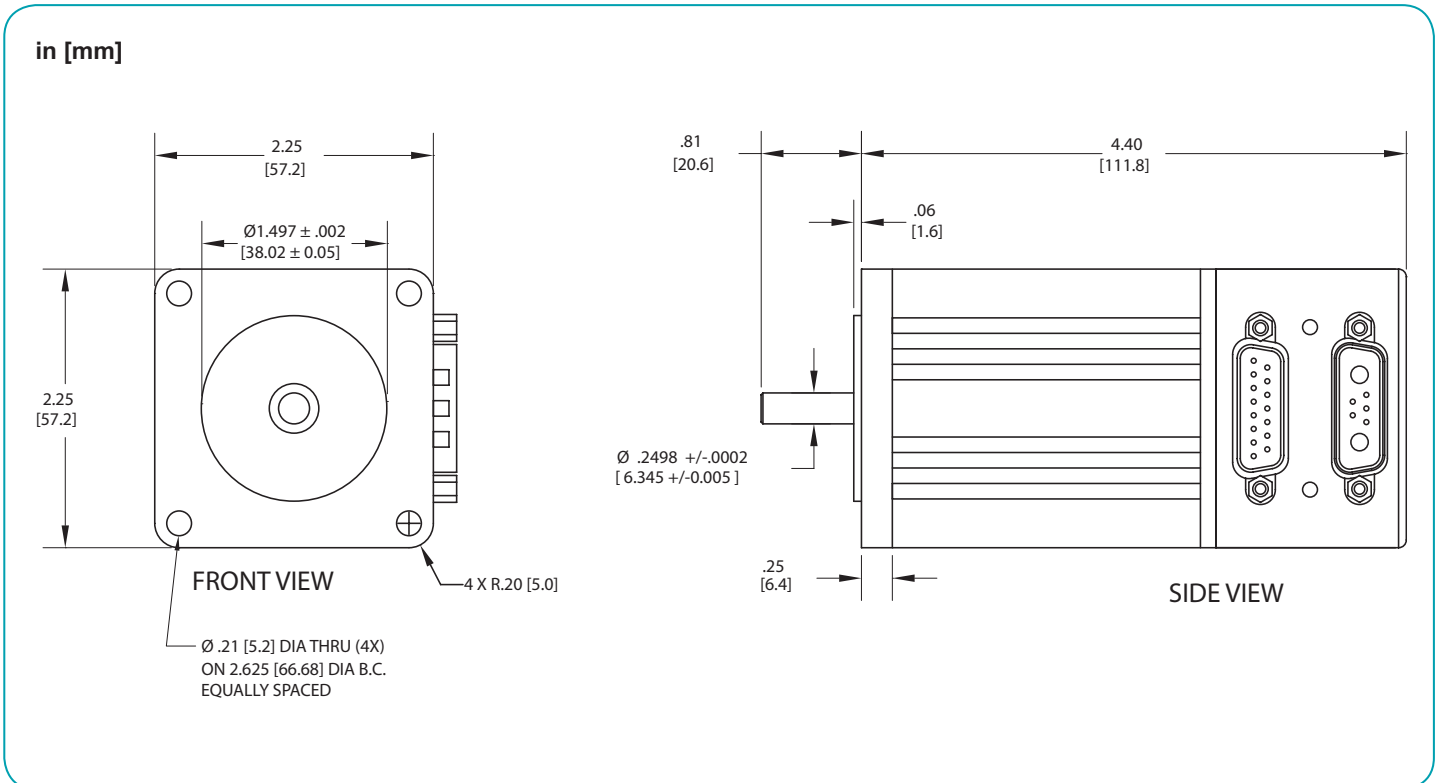

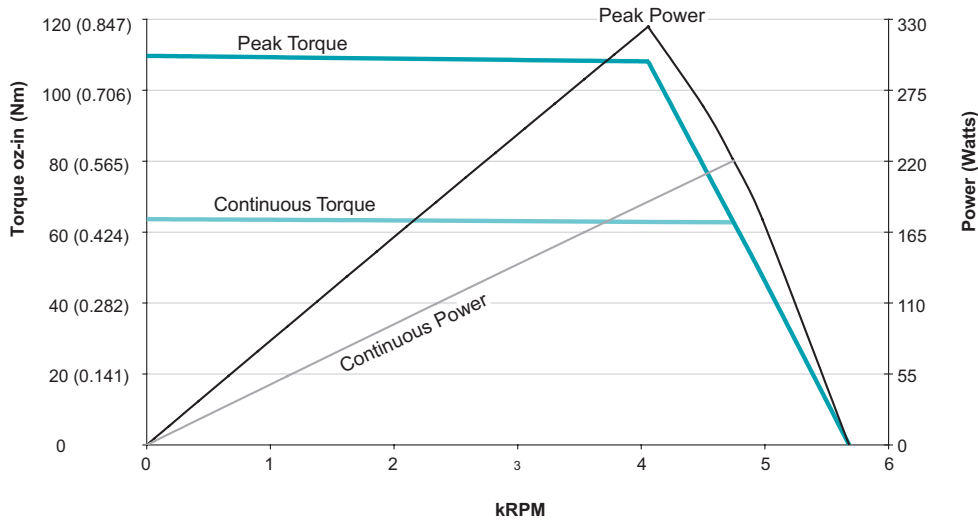

**SM23305D**  
**at 48 VDC**  
**at rise to 85°C**

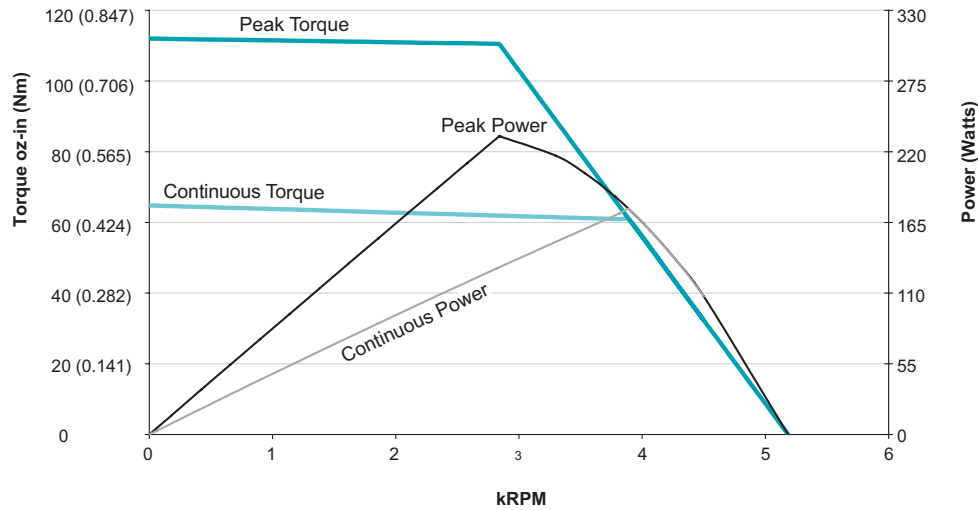

**SM23305D**  
**at 42 VDC**  
**at rise to 85°C**

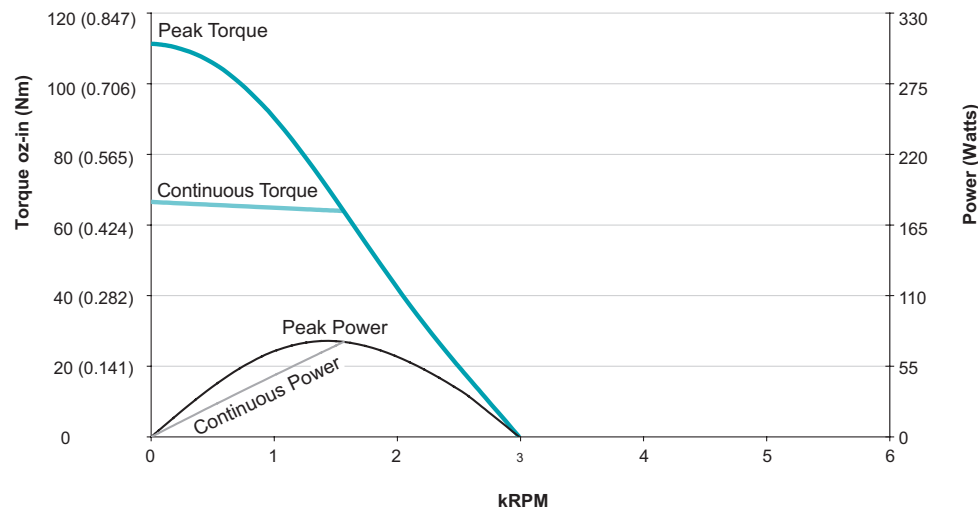

**SM23305D**  
**at 24 VDC**  
**at rise to 85°C**