

OVERVIEW

MOTOR SPECIFICATIONS

LINEAR SYSTEMS

CONNECTIVITY

PERIPHERALS

IP 65 MODELS & CONNECTIVITY

POWER SUPPLIES & SHUNTS

GEAR HEADS

SOFTWARE

APPENDIX

SM34305D		
Continuous Torque	10.87	in-lb
	174	oz-in
	1.23	N-m
Peak Torque	34.75	in-lb
	556	oz-in
	3.93	N-m
Nominal Continuous Power	400	Watt
No Load Speed	4,100	RPM
Continuous Current @ Nominal Power	10.9	Amps
Voltage Constant	12.1	V/kRPM
Winding Resistance	0.9	ohms
Encoder Resolution	8,000	Counts/Rev
Rotor Inertia	0.019	oz-in-sec ²
	13.422	10 ⁻⁵ Kg-m ²
Weight	4.5	lb
	2.04	kg
Shaft Diameter	0.375	in
	9.53	mm
Shaft, Radial Load	15	lb
	6.80	kg
Shaft, Axial Thrust Load	3	lb
	1.36	kg
DeviceNet Available	Yes	
ProfiBus Available		
CANopen Available	Yes	



Animatics SmartMotor SM34305D (No Options) CAD Drawing

in [mm]

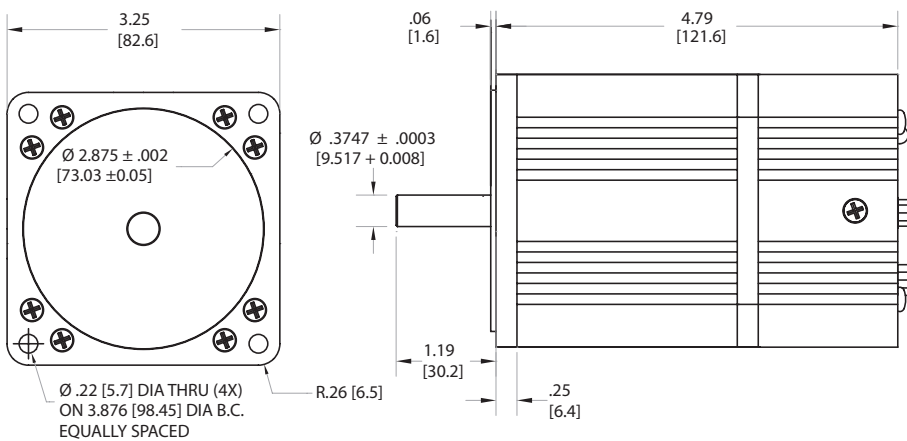

FRONT VIEW

SIDE VIEW

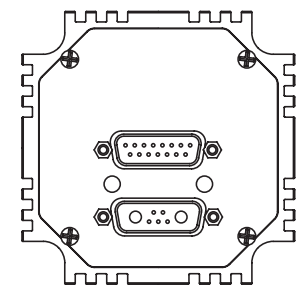

REAR VIEW

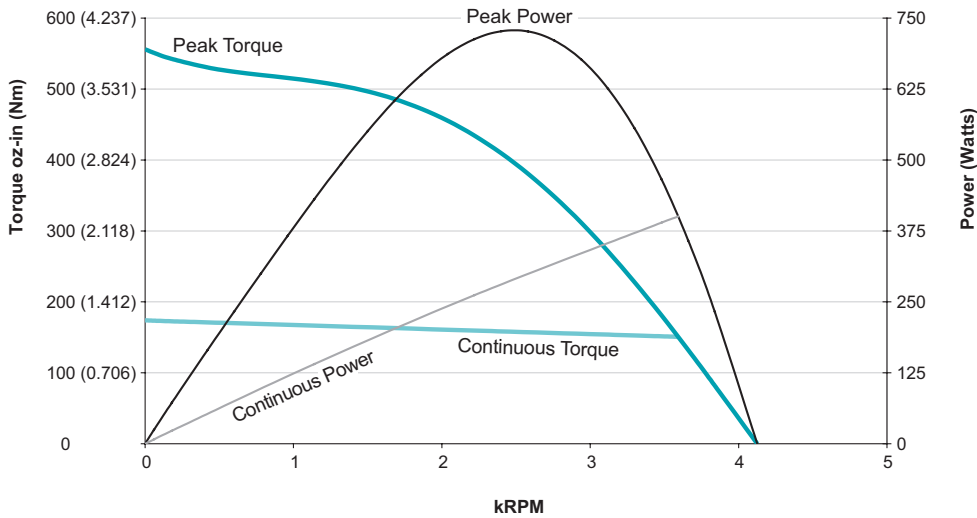

**SM34305D
at 48 VDC
at rise to 85°C**

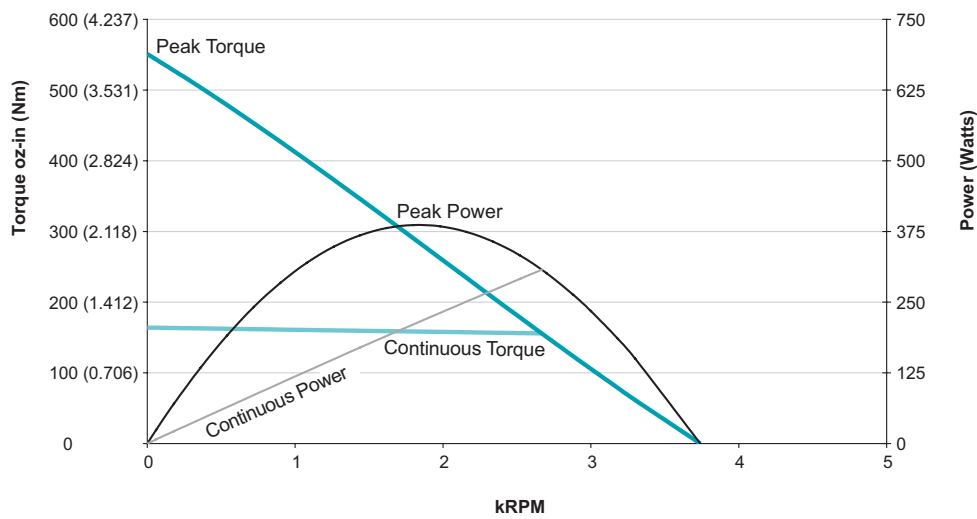

**SM34305D
at 42 VDC
at rise to 85°C**

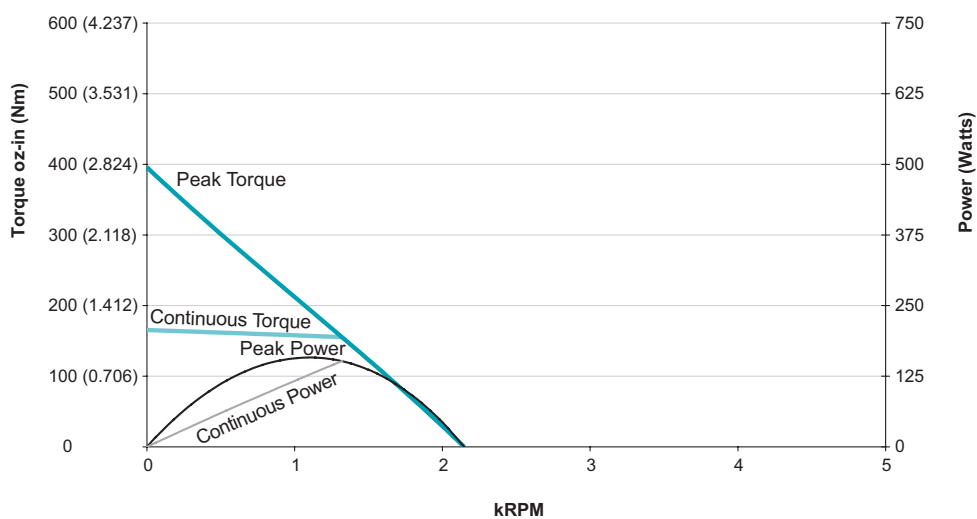

**SM34305D
at 24 VDC
at rise to 85°C**