

ANIMATICS®

Defining the future in motion control

Motion is our passion.

About Animatics

Thank you for using or considering the use of our innovative automation products. Headquartered in California and with offices around the world, Animatics Corporation has a unique approach to motion and machine control that can enable you to leapfrog your global competition. Before you dig into this catalog, we want to bring your attention to two critical areas where Animatics is the world leader:

1. Animatics offers the most highly integrated automation solutions in the industry. Starting with the SmartMotor™, the world's first fully-integrated Servo System, and extending through a large variety of I/O, machine control and actuator products, Animatics offers total solutions with a much smaller footprint and a lower cost, with a simplicity that reduces your machine development and build time – getting you to market faster.
2. With offices in Tokyo, California, New York and Continental Europe, the sun never sets on Animatics while we directly support key customers along with a global network of factory trained Automation Solution Providers; independent companies in your backyard ready to supply and support your Animatics products through the long-haul.

This catalog contains all Class 5 SmartMotor™ products and

Animatics' Actuator line (OEM Dynamics). All of the SmartMotor™ servos in this catalog have the latest feature set and are recommended for new designs. Earlier SmartMotor versions will continue to be sold and supported, but the best functionality and value will be found in the latest versions. Every effort has been made toward backward compatibility and little effort is required to adjust to the newer versions.

Future products will be released as "Classes" with each Class optimized for different markets, price points and applications exploiting an even greater variety of network protocols, industrial I/O capabilities and environmental sealing options.

Thank you again and welcome to Animatics, "*Defining the Future of Motion Control™*".



ANIMATICS®

Defining the Future of Motion Control

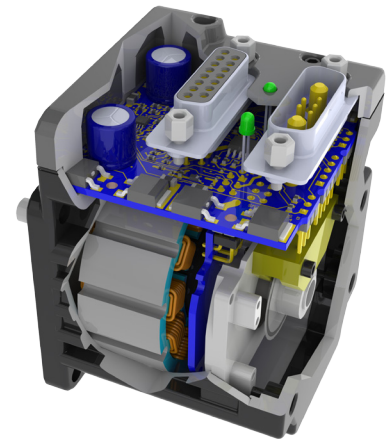

Notice: All SmartMotor™, Actuator and Product specifications are subject to change without notice.

Consult Website or Factory for latest data.

www.animatics.com

+1 (408) 748-8721

info@animatics.com

◆ We define the future of motion control by innovation, invention, and a dedication to the highest standards of professionalism and quality in everything we do and in every product that we make.

◆ We invite quality firms to ally with us and to participate in our inventions and innovations for the benefit of the companies that need and use our advanced technology and products.

◆ We invite our customers and users to join with us in the joint development of custom products and systems using our technology.

◆ We commit to providing a fair workplace for our employees. We subscribe to the principle of being a good corporate citizen, a good neighbor, and a protector of our environment.



The Animatics Overview

- 4 Defining the Future of Motion Control
- 5 Animatics Institute
- 6 Class 5 Overview
- 8 SmartMotor™ Modes of Operation
- 10 CAM Mode with Advanced Capabilities.
- 12 Combitronic™ Communications
- 13 Combitronic™ with RS 232 Interface
- 14 Introduction to Applications
- 16 Example Applications
- 18 Total Benefits of Integrated Motion Control
- 20 SmartMotor™ Advantage
- 21 Understanding Part Numbers

Motor Specifications

- 22 Fieldbus Protocol Options
- 24 Torque Curves
- 26 SM17205D
- 28 SM23165D
- 30 SM23165DT
- 32 SM23375D
- 34 SM23375DT
- 36 SM23205D
- 38 SM23305D
- 40 SM23405D
- 42 SM34165D
- 44 SM34165DT
- 46 SM34205D
- 48 SM34305D
- 50 SM34405D
- 52 SM34505D
- 54 CAD Drawings

Linear Systems

- 76 Table Top Robot (TTR)
- 78 Specifications for 3-Axis Systems
- 79 Specifications for 2-Axis Systems
- 80 Actuator Overview
- 81 Understanding Part Numbers
- 82 Actuator Comparison Chart
- 84 Actuators
- 106 Multi-Axis Configurations
- 108 Understanding Actuator Loading
- 109 Thrust Curves

Connectivity

- 128 Introduction to Class Connectivity
- 129 Class 5 Connector Pinouts
- 130 Class 5 LEDs and Connectors
- 131 Class 5 Connection Maps
- 135 Power & Communication Cables
- 138 I/O Cables
- 140 CAN Bus Communications Cables
- 142 CAN Bus T Connector and Shunts
- 143 Expanded I/O Cables
- 144 Custom Order Cables
- 146 Isolated RS485 Cable

- 147 Demo and Test Cable
- 148 Communications Adapters
- 149 New User Development Kits & Connectors

Peripherals

- 150 Motor I/O Connector Breakout Board
- 151 Serial Fan-Out Board
- 152 I/O Adapters
- 154 Demonstration, Testing & Development

IP 65 Models

- 156 IP 65 Models
- 160 Drive & Control Power Cable
- 161 Power & Communication Cables
- 162 Comm. & Encoder Bus Flying Lead Cable
- 163 Comm. & Encoder Bus Y Cable
- 164 Travel Limit Input Cables
- 165 Travel Limit Breakout Cables
- 166 CAN Bus Communications Cables
- 168 I/O Cables

Power Supplies & Shunts

- 170 How to Choose Power Supplies
- 171 Open Frame Linear Unregulated DC Power Supplies
- 172 Enclosed Switch Mode DC Power Supply
- 176 Enclosed DC Power Supplies
- 177 Introduction to Shunts
- 178 Open Frame Shunts
- 179 Enclosed Shunts

Gearheads

- 180 Moment of Inertia Overview
- 181 Introduction to Gearheads
- 182 High Performance Planetary Gearheads
- 188 OEM Series Planetary Gearheads
- 194 Right Angle Planetary Gearheads

Software

- 197 Software Overview
- 198 Interface Software
- 200 CNC Software
- 202 Code Development Software

Appendix

- 204 Application Sizing Equations
- 206 Motion Glossary
- 209 Command Set Overview
- 213 FAQ
- 216 Controls, Warning & Cautions
- 218 Conformity Statement
- 219 Animatics Warranty
- 220 SmartMotor™ Success Checklist



from Animatics

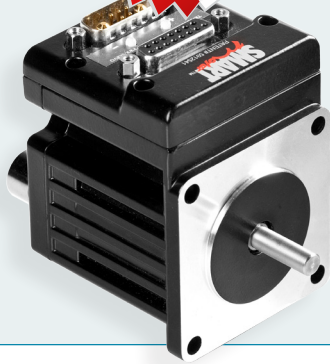

Class 5 SmartMotor™

Delivering significant industry advancements in programmable integrated servo systems

The Class 5 SmartMotor servos have the most advanced motion control feature set of any comparable product on the market and are recommended for designs of the highest caliber.

- 5x faster processing speed
- Expanded math function capability
- Multi-port simultaneous communication
- Stand-alone Linear Interpolation
- Modulo encoder count capabilities
- Dual trajectory path generators

COMBITRONIC™ Communications

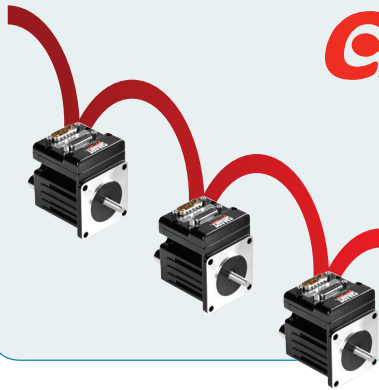

- Links up to 120 SmartMotor servos over CAN bus
- Any SmartMotor™ can read, write, control any other SmartMotor
- No explicit communication code is necessary
- Entire machine programs written in the time it would take to program a motion controller to talk to a PLC
- An array of connected SmartMotors become one giant parallel processing system

IP65 Models

SM34165MT-IP



- IP65 rated sealed servo for harsh environments; optional IP67 available
- 10 channels of configurable 24V I/O
- Configurable LED indication
- Available in NEMA 23 & 34 frame sizes



Table Top Robot

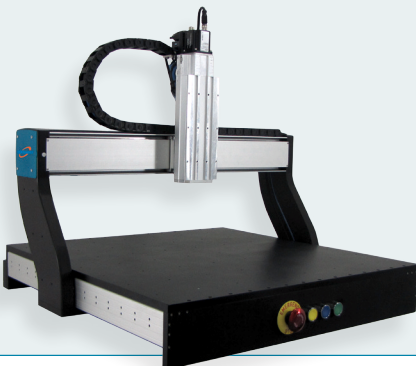

- Number of axes: 2 axes / 3 axes
- High Repeatability: 16 Microns
- Work Envelope: Up to 600mm by 550mm by 250mm
- Load Capability: Up to 45Kg load at 250mm/sec
- Highly Configurable



Defining the Future in Motion Control

OVERVIEW
MOTOR SPECIFICATIONS
LINEAR SYSTEMS
CONNECTIVITY
PERIPHERALS
IP 65 MODELS & CONNECTIVITY
POWER SUPPLIES & SHUNTS
GEAR HEADS
SOFTWARE
APPENDIX

Not Just a Product

What makes the Animatics SmartMotor by far the most powerful Integrated Motor in the industry is its unique ability to control an entire machine. The SmartMotor is not just a product; it is a byproduct of an innovative design philosophy. The unsurpassed combination of programmability ease, networking capability, highly flexible and expandable I/O, and high power density servo performance is exactly what you should expect from the pioneer and recognized global leader of truly integrated motion control.

The Animatics SmartMotor is a complete, compact, and user-friendly integrated motion control system that actually meets the textbook definition of a robot. Our line of advanced rotary and linear motion control products feature the ability to perform multi-axis motion including stand-alone coordinated motion. While priced similarly to other integrated servos, the SmartMotor brings real-world additional savings to the machine builder by eradicating other expensive and complicated elements in the machine such as PLCs, sensors, I/O blocks, and control cabinets. Additional axes can be easily added in the field, bringing additional processing power, but without parallel growth of existing cabinet size.

This simplicity and ease of use goes beyond just “compactness;” it results in overall reduced machine development time (shortening time-to-market), lower total machine cost, greater field reliability, and simplified machine design and build time, eliminating heavy procurement and support activities.

Will your new machine design be rooted in old 1978 PLC technology or will you take advantage of advanced Animatics SmartTechnology™ to gain a dramatic savings in time and money that will put you miles ahead of your competition? New technology results from new, innovative approaches after careful study of the weakness and limitations of prior methods and technology. By far the greatest benefit of using the SmartMotor is that it lets you trump your competition by getting a dominant product to market weeks or potentially months sooner. Let our global network of factory-trained Automation Solution Providers show you how.

Unparalleled Customer Support

Customer support is a key area where Animatics separates itself from the pack. We offer products at a cost you would think could only come without support, and yet we have a global network of factory trained support engineers dedicated to keeping you productive.

This support network is two-layer. It starts with a direct Animatics office in every major market and time zone, and continues with a second layer of factory-trained engineers employed by our distributors and Automation Solution Providers residing, most likely, in your own backyard.

Our global support network is not just for emergency response. It is also very useful for training and installation assistance. The absolute best thing our network of engineering support can do for you is help you reexamine your machine design with an eye for leveraging the unique features of our integrated motion systems. They can also show you how to approach your design so any part of the machine is serviceable anywhere, any time, by anyone with a screw driver. Leverage this design approach and learn how your customer can enjoy effectively ZERO downtime.

Available Software

SmartMotor Interface (SMI) is your window to the SmartMotor and it is available free-of-charge. It is Microsoft Windows compatible, and together with a desktop or laptop computer

equipped with an RS-232 port, you have everything you need to converse with anywhere from 1 to 100 SmartMotor servos. Smart Select Interface™ (SSI) is a point-and-click configuration tool for programming SmartMotor for various pre-set motion profiles.

What's New

This catalog features the new **Class 5 SmartMotor technology** offering significant industry advancements in programmable integrated servo systems. New modes of operation and capabilities such as stand-alone coordinated motion open up infinite new applications for Animatics' fully integrated motion control solutions.

The new **Combitronic™** high speed transparent communications over CAN bus provides all the benefits of distributed machine control without the traditional limitations and drawbacks. The new line of rugged **IP 65 rated** NEMA 23 and 34 frame DC-input servos provides new solutions for harsh and demanding environments.

Animatics.com Web Site

Download software, check for the latest product information and updates, view literature, product manuals, application videos and ideas, get technical support, and locate your nearest representative on Animatics' user friendly site.

Animatics Institute

Learn essential product, application, and game-changing machine building strategies at the Animatics company headquarters in Santa Clara, California.

Available to a wide variety of customers and potential customers of our innovative rotary and linear solutions, this comprehensive training culminates in hands-on machine building lessons.

Commitment to the Environment & Sustainability

Animatics deeply believes in being a responsible caretaker of our natural environment and conserving scarce resources. The SmartMotor is made in the same shaft and frame dimensions as open-loop step motors, but use a small fraction of the electrical draw because they only use as much power as the load physically needs. Open-loop step motors are always “on,” drawing as many as several amps, just to hold still, causing increased heat generation.

Although step motors have a lower initial purchase cost, the use of large amounts of power from a single step motor will cost hundreds of dollars more in electricity alone through the life of a machine. Selecting a single size 34 SmartMotor instead of a step motor, for example, could spare the release of as many as 10 metric tonnes of CO2 into the atmosphere over its life.

Because SmartMotors are made a fraction of the size of a traditional control system, and with considerably less cabling, the manufacturer who utilizes the SmartMotor consumes far less material. Its self-contained nature means the SmartMotor is better than recyclable; it's reusable. Most machines will reach the end of their useful lives long before the SmartMotor will, and transferring them to another machine is easy because the components are in one integrated component and the cabling is simple.



Animatics Institute

Training for the Animatics SmartMotor™ product is conducted by the Animatics Institute, which offers a variety of training programs and seminars for Automation Solution Providers (ASPs), Consultants, Distributors, Engineers, Machine Builders, OEMs, System Integrators, and Users of Animatics rotary and linear products and systems. The training programs include:

- Application solutions that lower costs, improve reliability and speed up your time to market. Covers a variety of machine types and systems as well as a variety of markets. Opportunities to do machine design in real time at our headquarters
- Basic principles of machine and system economics
- Economics of machine and system design including comparative analysis, time-to-market values and more : the key to winning in the marketplace.
- Essential information about the SmartMotor and how it works including field bus options, introduction to programming, avoiding common problems, and trouble-shooting.
- Master/Slave solutions: when to use them and when to avoid them
- PLC-free systems
- Sales and marketing strategies for Smart products and systems
- SmartTechnologies™ and how to get the most out of them

Certificates are awarded upon satisfactory completion of courses. Programs cover more than one topic and typically last five days with opportunities for 2-week sessions.

Call 408.748.8721 and ask for Sales for additional information.

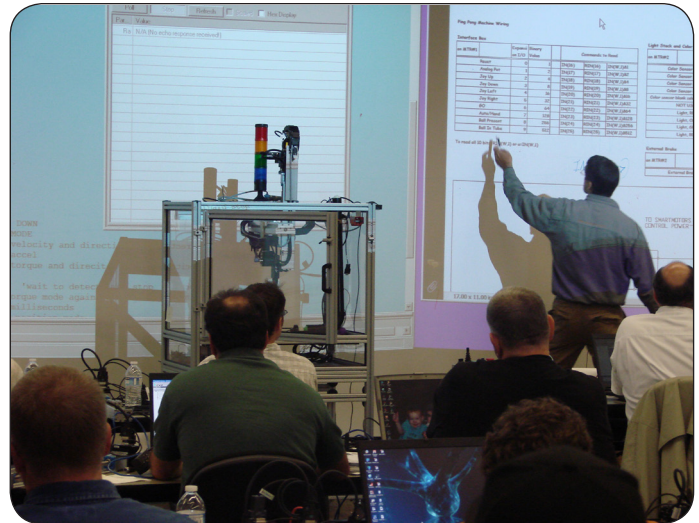

Class 5 Control Overview

- Faster Processor, greater than 5 time faster than Existing Class 4 Motors
- Faster RS232 / RS485 Communications Speeds, up to 115.2KBaud means unparalleled connectivity
- Multi-Port Simultaneous Communications, RS 232/RS 485/ CAN Bus
- Enhanced Trap Mode Commutation
- Expanded Math Function Capability with Floating Point Math & Trigonometric Functions
- Modulo Encoder Count Capability
- 8 Level Priority Stacked User Definable Interrupts
- 4 User Definable Independent Timers
- DE/Dt: Rate of Change of Following Error Limit
- Increased I/O Interrupt Assignments
- Software Programmable Limits can be set to trigger interrupts w/o fault
- Enhanced Parameter and Function Based Syntax
- Increased System Status Bit Registers for Advanced Diagnostics
- Optional On-board Expanded I/O : 10 Channels 24VDC Isolated Assignable as Inputs or Outputs
- Optional 10 additional points of isolated 24V I/O source up to 300mA and read both digital and analog signals
- 4 times faster PID update rate (down to 62.5µsec) enables ultra precise motion
- Optional CANopen communications with high speed contouring to sub-millisecond synchronization
- New Sinusoidal Commutation capability delivers smooth and quiet motion, even at low speeds
- Commutative, Associative, and Distributive math syntax
- Software Programmable Limits can be used as programmable electronic Cam switch triggers

Enhanced Trap Mode and Sine Mode Commutation:

The motors can be operated with encoder-based commutation that allows for a more precise alignment and association of rotor to stator magnetic phases. The result is a smooth, quiet rotation with very low cogging. As a result, much slower commanded speeds may be achieved with little speed fluctuation.

Higher Frequency PID Update Rate:

User selectable PID update rate defaults to 125 microseconds. Optionally it may be decreased or increased. The faster 62.5 microsecond update rate allows for smoother high speed operation and faster accel/decel correction under varying load conditions.

Expanded Math Function Capability:

Class 5 SmartMotor™ includes:

- Added Boolean operators such as Exclusive OR and Modulo,
- Trigonometry functions, SIN, COS, TAN, ASIN, ACOS, ATAN
- Absolute Value
- IEEE-754 Single Precision Floats
- Commutative and Associative math operations are allowed with up to 128 characters on the right side of an equal sign.

Advantages over Conventional Systems

- High noise immunity
- Low emissions
- Very high tuning bandwidth (very stable)
- Very compact motion system (Shortest axial length closed-loop servo available)

Power & Encoder

Drive Power:	+20 - 48VDC
Control Power:	+20 - 48VDC (must be supplied separately when DE option is ordered)
Expanded I/O Option:	+24VDC isolated (must be supplied)
Commutation:	Trapezoidal (Default) Enhanced Trapezoidal based on Encoder Position Sinusoidal
Encoder Resolution	23 Frame: 4000 counts per revolution (Class 5) 34 Frame: 8000 counts per revolution (Class 5)

Processor/Clocks:

Processor Clock Speed:	32MHz
PWM Switching Frequency:	16KHz
CPU Regulator Frequency:	140KHz +/-10% load dependant
Drive Stage Regulator:	100MHz

PID Update Rates: 8KHZ Adjustable

Programming:

Code:	Command Interpretive Text Based
Program:	32K Program/32K Data Storage
Subroutines:	up to 1000
Stack Pointers:	10 Nested GOSUB() and/or Interrupt calls

Communications:

RS-232:	2400 to 115200 Baud	9600 default
RS-485:	2400 to 115200 Baud	9600 default
(Optional) CAN Bus:	20K to 1MBaud	125000 default

New in Class 5: Dual Trajectory Path Generators

The processor now has the ability to sum in Positioning, Velocity, or Contouring mode profiles on top of Electronic Gearing or Camming profiles.

This also includes Virtual Axis gearing and Camming where independent profiles may be run off of a virtual time base separate from Position or Velocity Modes or summed in on top of them.

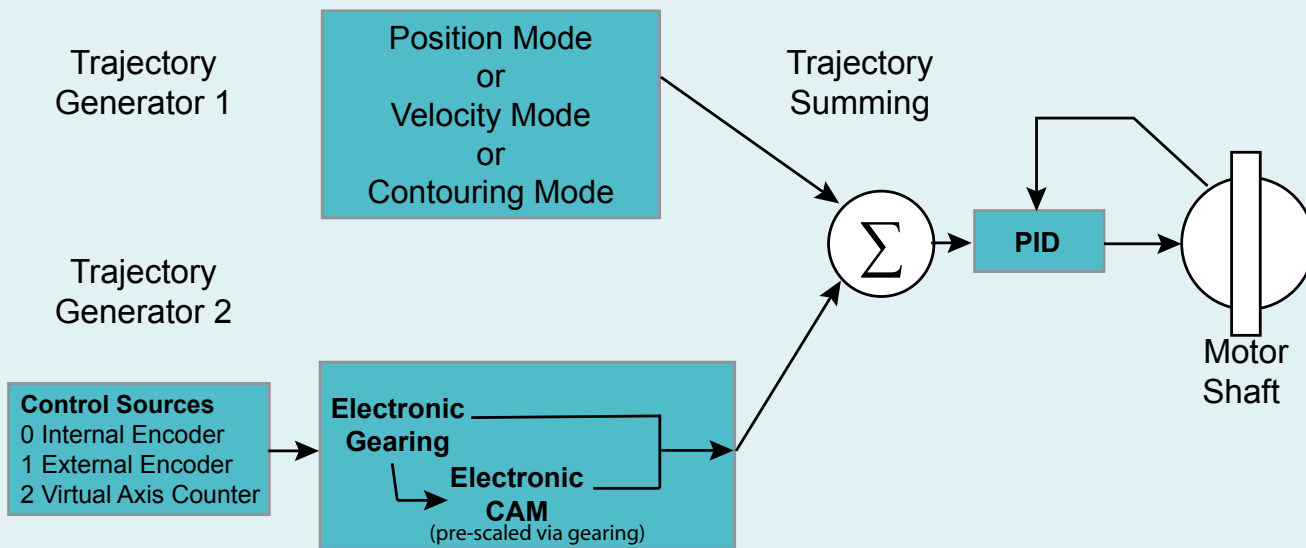

Velocity Mode and Electronic Gearing Summed Together:

Electronic Gearing ensures instant response to Master Nip Roller speed while Velocity Mode is controlled by the tension arm. The net effect is assurance of constant tension over the change in supply reel radius.

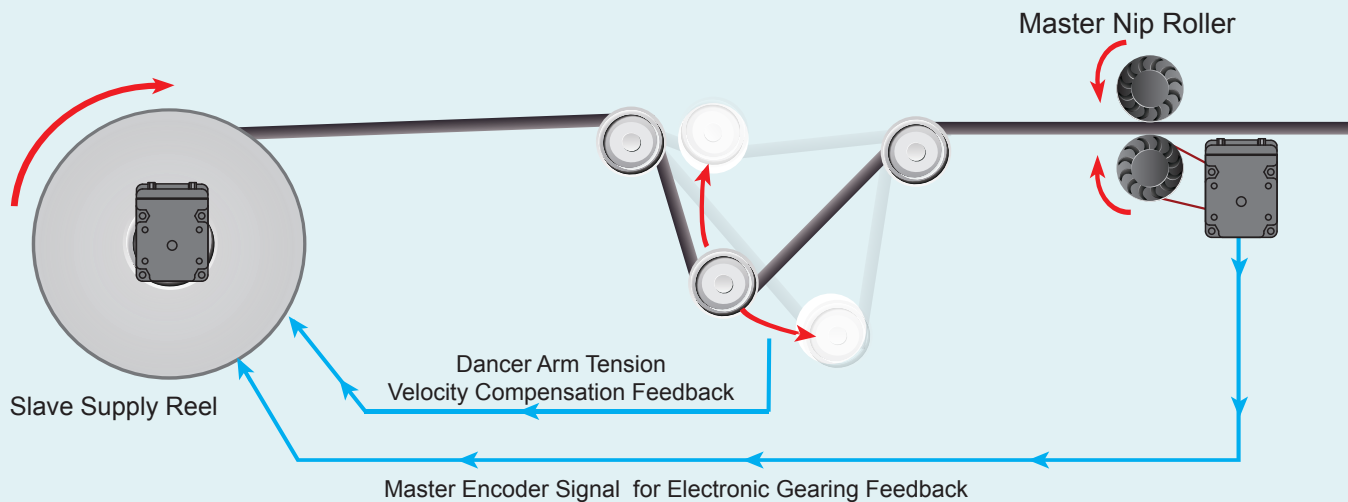

SmartMotor™ Modes of Operation

OVERVIEW
MOTOR SPECIFICATIONS
LINEAR SYSTEMS
CONNECTIVITY
PERIPHERALS
IP 65 MODELS & CONNECTIVITY
POWER SUPPLIES & SHUNTS
GEAR HEADS
SOFTWARE
APPENDIX

Torque Mode:

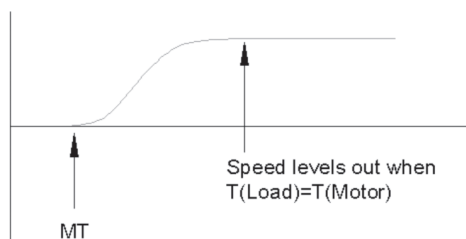

Open loop directional control of power to the motor windings. In this mode the motor has knowledge of encoder position but does not use it for motion. The motor will increase speed until its commanded torque equalizes with load torque. If load torque decreases, shaft speed will increase. If load torque increases, shaft speed will decrease. In a static condition, force applied will be proportional to commanded torque.

Velocity Mode:

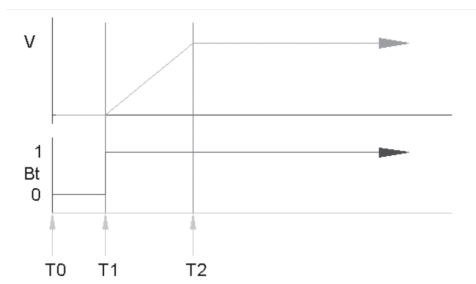

Closed loop speed control based on position over time, not frequency. This means that from the initial command to begin motion, the controller keeps track of what the actual position should be.

If load momentarily increases beyond the limits of the motor, shaft speed will be slightly reduced. If the load decreases back to within the capabilities of the motor, the shaft speed will increase beyond commanded speed in order to catch up to where it should have been had a constant velocity been maintained.

Position Mode:



Closed Loop control based on encoder feedback. All position mode moves are classified as either relative or absolute mode. Relative Mode means the motor is commanded to move a set distance in either direction relative to where the shaft is at the time.

Absolute Mode means the motor is commanded to move to a specific location regardless of initial position.

Mode Step (Step and Direction Input):

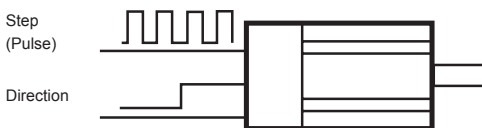

The motor will follow a standard step and direction input signal. A ratio of internal encoder counts to incoming pulses may be used. The step input can also be used as a high speed counter.

Phase Adjust Mode

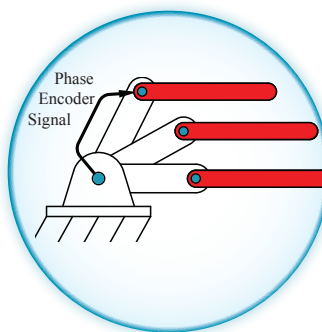

Enables applications such as product tracking where moves must be applied over a target in motion, automatically stabilizes pan & tilt applications, or allows arm end effectors to remain parallel to base while the mid arm section moves.

Phased Origin stays referenced to base allowing commanded moves to be DYNAMICALLY independent of the phase axis.

Expanded Electronic Gearing Functionality

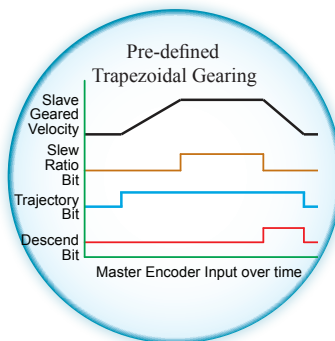

Now includes separate Ascend, Slew and Descend pre-defined distances that may be defined off of either master or slave encoder values for enhancing applications such as high speed winders.

With an array of status bits available, all portions of the move may be used for I/O triggering. Automatic transitions in and out are ideal for high speed labeling applications.

Modulo Count Mode

Modulo Count Mode allows the user to define maximum position counter rollover. Normally the shaft position counter can run anywhere from zero to $\pm 2^{31}$. This means the motor counter will continuously increase in the positive direction and when it hits its maximum, it will instantly go negative and begin counting down to zero. With Modulo Count Mode, the user can alternately set up a counter that will increase up to a given value and then roll directly over to zero and start counting up again. The count will never go negative, it will always be $0 \leq \text{modulo value} \leq (\text{Modulo Limit}-1)$. This mode is especially useful in rotary pan or azimuth controls for targeting systems, radar, and Camera bases. Combined with the Combitronic™ interface, multi Camera surveillance systems may more easily pass off subject tracking from one pan & tilt to the next.

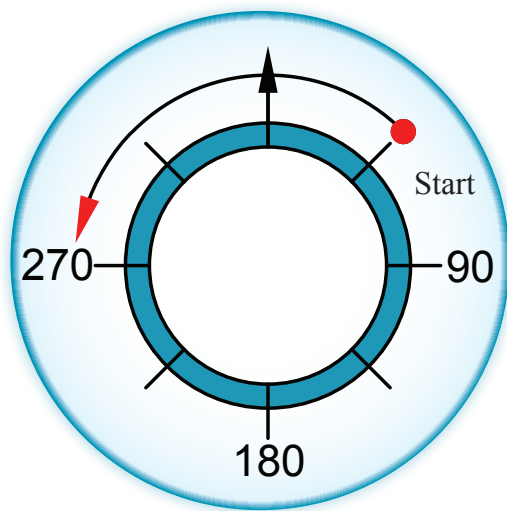

PML= 360 (Position Modulo Limit) maintain counts between 0 and 359

PMT= 270 (Position Modulo Target) take shortest path to Target Position.

DE/Dt: Rate of Change of Following Error Limit (Derivative Error Limit)

DEL (Derivative Error Limit) provides the safest fast-means to fault a motor on sudden changes in load or detection of human interference.

The purpose of this Limit is to act as a look ahead on following error. Instead of just triggering on a raw following error of how far behind in a move the motor may be, the processor is looking at how fast that following error changes.

DE/Dt refers to the dynamic rate of change of following error. This results in an instant release of energy and safer operation and less chance of damage to equipment or injury to machine operators. Under normal servo control following error limits, if the load collides against an object, the motor will not fault until the following error limit is reached. As a result, current and torque applied will increase until that condition is met. By adding an additional derivative limit on following error, the servo will fault out within microseconds of contact with the object.

Example:

```
DEL=VT 'Set limit to commanded speed
```

If DE/Dt equals commanded velocity, then the motor just hit a hard stop. Normally, the motor would have to continue applying torque until the normal following error is exceeded. However, if DEL (DE/Dt limit) is set to target velocity (VT), then the controller would error out immediately upon hitting a hard stop without any wind-up whatsoever.

Derivative Error Limit

(Rate of change of following error limit)

This feature quickly detects jams for safer operation and less chance of damage to equipment or injury to machine operators.

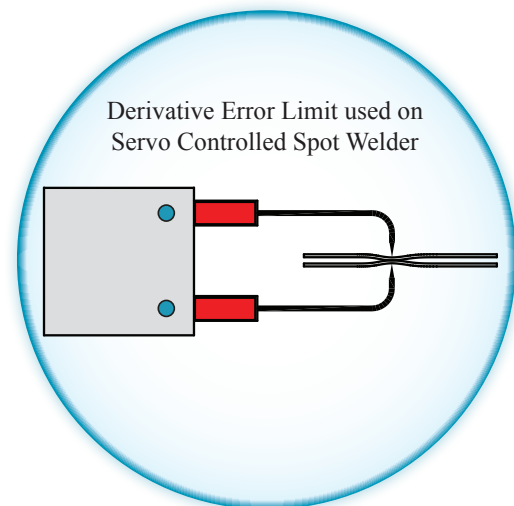

Jaw stops immediately upon making contact with metal for minimal product deflection and maximum balance to each side.

Cam Mode with Advanced Capabilities

Cam Mode

Electronic Camming is similar to mechanical Cams in that for a given master rotating device, a slave device tracks the speed and moves through a fixed profile of positions. In Electronic Camming, the profile is a look-up table of data stored in the slave motor.

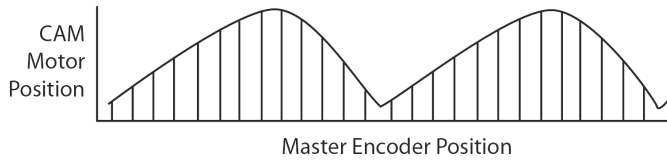

Cam data can run from CPU RAM or Flash. Extra CAM data may be stored in EEPROM as well. CAM Mode data may be run using either Fixed Master segment length or variable master segment length.

- RAM storage: 1 CAM table
 - 52 fixed length data points, 35 variable length data points
- Flash storage: 9 CAM tables
 - 750 fixed length data points, 500 variable length data points
- EEPROM: Up to 8000 points total may be stored and moved to flash or RAM.

Powerful & Advanced Capabilities

- Multiple profile tables may be stored & called upon when required
- Dynamic tables can be created in real time for cases where amplitude or frequency and even actual specific points may need to be changed on the fly
- The master signal may be either an external encoder input from another motor, or it may be from an internal virtual axis encoder signal

Use Cam Table to Control Entire Machine Process

Data is in the form of slave positions and master position deviations. Table data may be fixed Master position deviation where only slave data is stored or may be variable segment master data and slave data combined. In addition, each Cam data point has an additional 8 points of control data. This control data may be used to define interrupt Status Bits for controlling I/O or move events, as well as defining a given point as linear, or curvilinear spline points.

All Cam tables may be run as standard linear interpolation or a modified spline algorithm. When running in Spline Mode, the data points may be greatly reduced. The sample diagram (Fig. 1) shows an X Y plot of Cam tables running on two motors. While the original data was over 700 points, the final data was around 30 points in each motor.

Fig. 1

In Spline Mode, only 30 data points in each SmartMotor™ were required to control the entire path of motion.

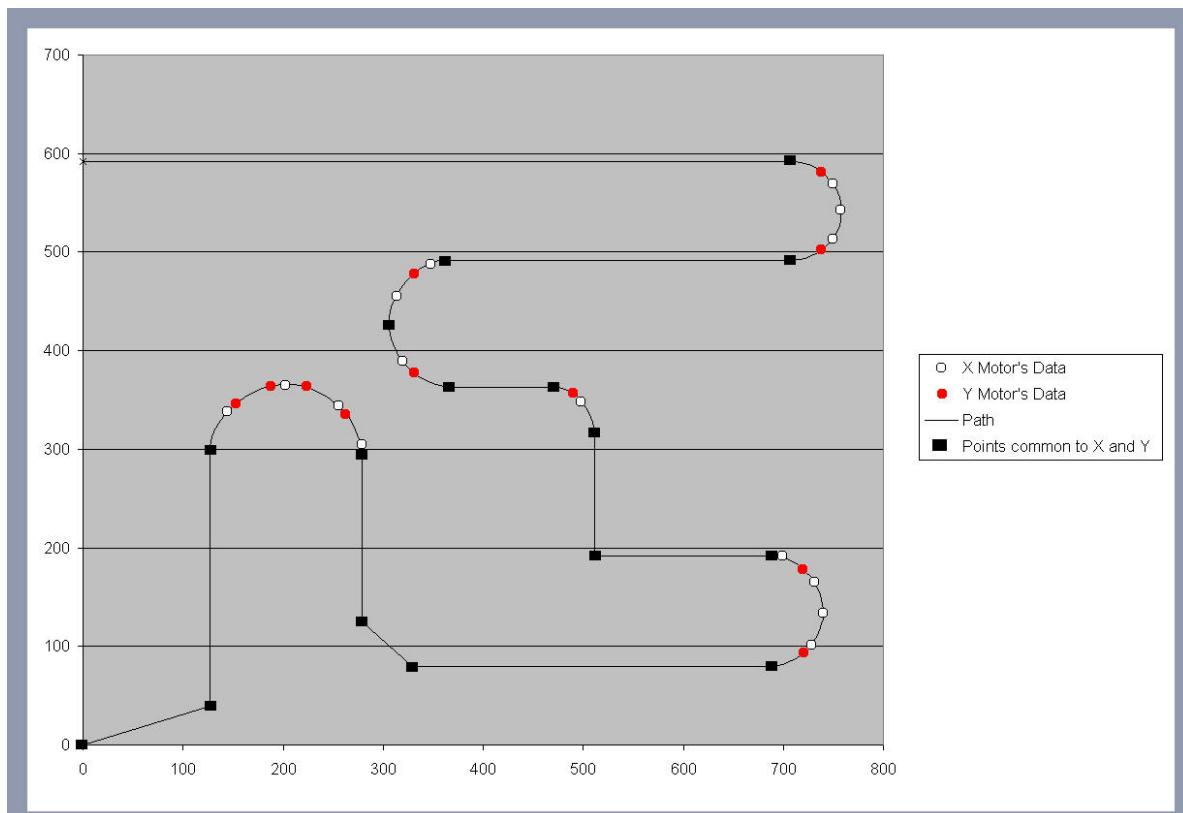

Cam Mode may be used for complete stand-alone coordinated motion

Fig. 2

The example data for motor 1 is shown below

CTE(1)	CTW(511,29900)
CTA(30,0)	CTW(509,32600)
CTW(0,0)	CTW(498,33100)
CTW(126,2600)	CTW(456,34000)
CTW(130,8200)	CTW(334,36500)
CTW(156,9100)	CTW(312,37200)
CTW(253,11200)	CTW(306,37900)
CTW(273,11900)	CTW(323,38700)
CTW(279,12500)	CTW(372,39800)
CTW(279,15700)	CTW(740,47200)
CTW(329,15800)	CTW(756,47800)
CTW(717,23600)	CTW(756,48400)
CTW(737,24300)	CTW(743,48900)
CTW(739,24800)	CTW(687,50100)
CTW(727,25400)	CTW(0,63900)
CTW(699,26100)	CTW(0,75600)

Flexible Approach

- Cam Table data may be directly imported from a tab delimited text file of spread sheet
- Imported data in SMI can be written into a program, copied to the clipboard or directly written (live) into a motor
- Import function allows for optimizing data points for cubic spline interpolation

Fig. 3

Below is the Cam Display window in SMI you see when importing data. Clicking the "Copy Simplified Points to Clipboard" button on the bottom left side of the Cam Display window in SMI results in Fig. 2 above.

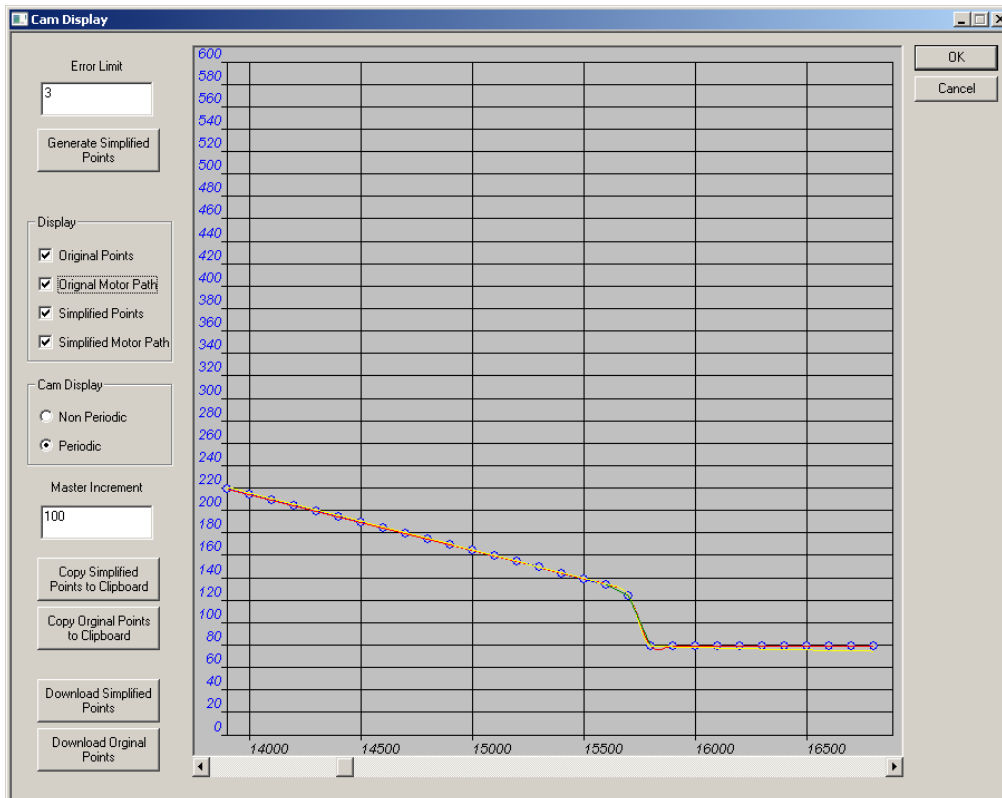

Introducing **COMBITRONIC™** Communications High Speed Transparent Communications over CAN bus

Animatics Corporation has introduced a significant advancement in Integrated Motor Technology. Combitronic™ is a protocol that operates over a standard “CAN” (Controller Area Network) interface. It may coexist with either CANopen or DeviceNet protocols at the same time. Unlike these common protocols however, Combitronic™ requires no single dedicated master to operate. Each Integrated Servo connected to the same network communicates on an equal footing, sharing all information, and therefore, sharing all processing resources. Combitronic communications operate over a standard “CAN” interface, the same basic hardware used in most automobiles as well as in familiar industrial networks such as CANopen and DeviceNet. Unlike these common control networks, however, Combitronic has no master or slave.



An array of Animatics SmartMotor servos become one giant parallel-processing system when equipped with the Combitronic™ interface. This powerful technological advancement provides the joint benefits of centralized and distributed control while eliminating their respective historical drawbacks, opening up the possibility to either:

- Eliminate PLCs from machine designs or
- Enhancing the performance of existing PLCs by unburdening it from specific tasks

The optional Combitronic™ technology allows any motor’s program to read from, write to, or control any other motor simply by tagging a local variable or command with the other motor’s CAN address. All SmartMotor™ units become one multi-tasking, data-sharing system without writing a single line of communications code or requiring detailed knowledge of the CAN protocol. The only prerequisite is to have matched baud rates and unique addresses.

Up to 120 SmartMotor servos may be addressed on a single array using Combitronic technology.

Combitronic Protocol features:

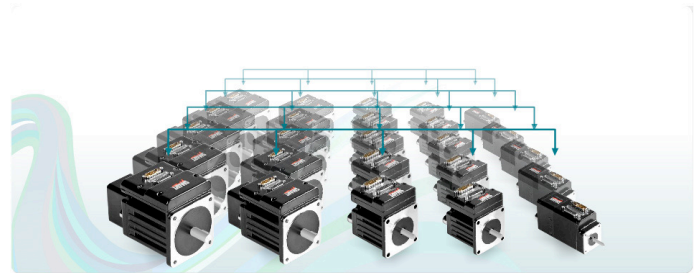

- 120 axis node count
- 1MHz Bandwidth
- No Master required
- No scan list or node list set up required
- All Nodes have full read/write access to all other nodes

For example, SmartMotor servos use a single letter command to start a motion profile, so a line of code to start a motion profile would look like this:

```
G      Issue Go in local motor
G:2    Issue Go to Motor 2
G:0    Issue Global Go to all motors on the network
x=PA:5 Assign Motor 5 Actual position to the variable "x"
```

Additionally, comparisons or live polling and value comparisons may be made across the bus:

```
IF PA:3>PA:5    If motor 3 position exceeds motor 5
                  position
                S:2    Stop motor 3
ENDIF
WHILE IN (4) : 2==0 LOOP Wait for Input 4 of motor 2
                    to go high
```

New Stand Alone Linear Interpolation:

```
\Assign commanded positions for x, y, and z
x=123000
y=20000
z=8000
\Use variables to define motor addresses
VTS=100000    \set path velocity
ATS=1000      \set path acceleration
DTS=100       \set path deceleration
PTS(x;1,y;2,z;3) \set 3-axis synchronized
                target position
GS            \Go, 3 axis synchronized
                linear interpolation
TSWAIT       \Wait until 3 axis move
                is complete
```

Combitronic™ with RS 232 Interface

In the event that a PC or HMI is desired to control a large number of SmartMotors, but RS232 is desired to save the cost of direct CANbus interfacing to the network, any SmartMotor may be used as master access via RS232 to all Combitronic motors on its network. The following demonstrate 12 motors in a network where 4 SmartMotors are in a serial daisy chain over RS232. Each of those 4 may have up to 119 motors on its Combitronic network.

The Controlling PC may freely access and control all motors via a single standard RS232 serial port.

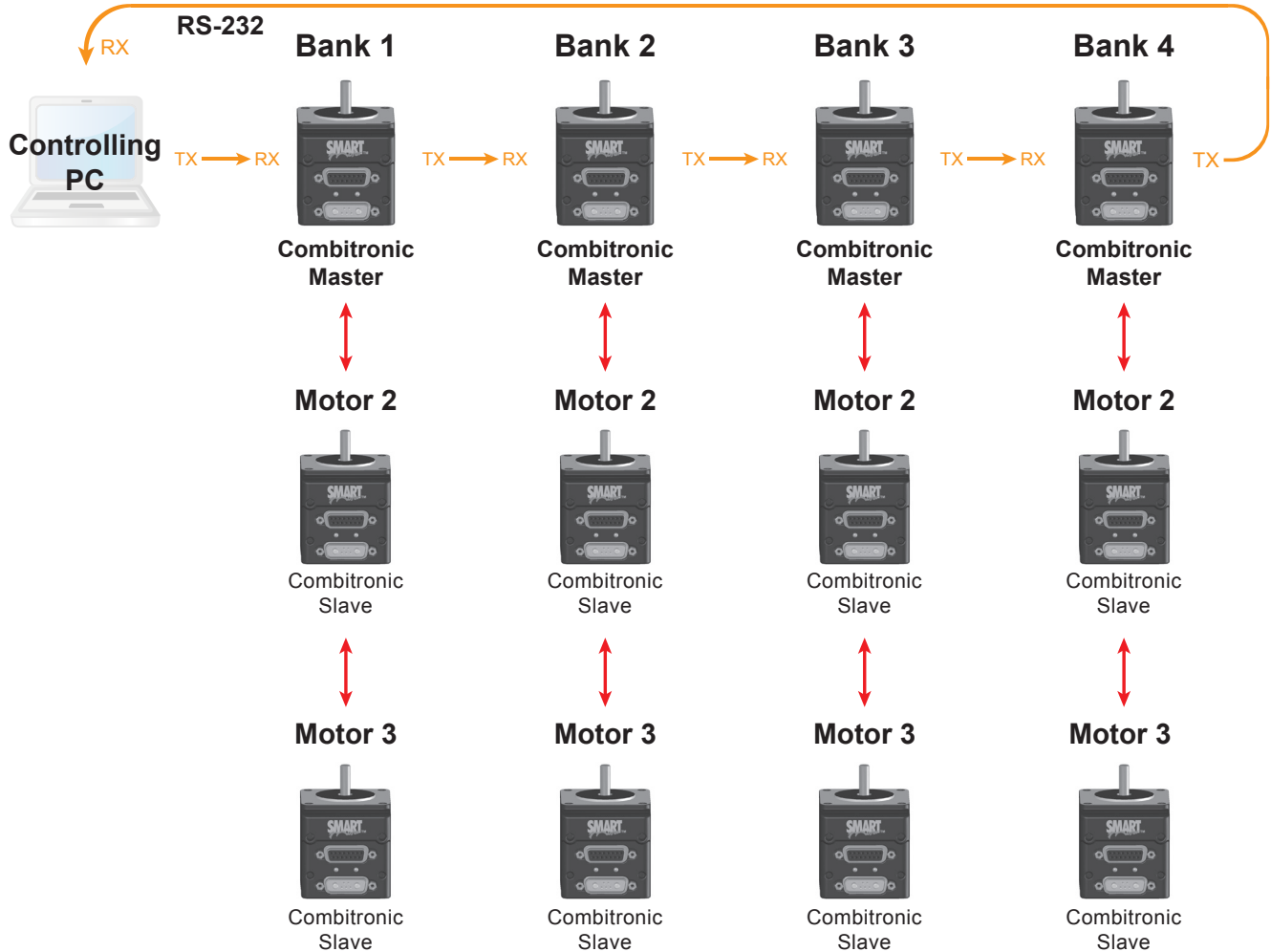

Example of RS232 commands form Host PC using SMI software for above system layout:

- | | |
|------------|--|
| 2PT:3=1234 | <i>Motor 2 sets target position of Motor 3 in its group to 1234</i> |
| 3PT:0=0 | <i>Motor 3 sets target position of all motors in its group to zero</i> |
| 4PT=345 | <i>Just Motor 4 gets its own target position set to 345</i> |
| 0G | <i>Motor 1, 2, 3, and 4 get Go command</i> |
| 0G:0 | <i>All motors on RS232 and all network Combitronic motors receive Go command</i> |

For over 20 years, Animatics has been providing customers of numerous industries with the products and customer service to help them succeed. Animatics' products are at the heart of applications ranging from process tension control to parallel axis gantry, and our returning customers in old and new industries are a testament to our innovation. So many unique applications feature our products that we have recently begun compiling our own library of success stories. Is your story next?

Each SmartMotor™ can freely move between modes of operations including:

- Velocity Mode
- Torque Mode
- Relative Position Mode
- Absolute Position Mode
- Electronic Gearing
- Electronic Camming

Industries using SmartMotor™:

- Aerospace
- Agricultural
- Automotive
- Autonomous vehicles
- Biomedical
- Chemical
- Cryogenics



- Government
- Life sciences
- Marine sciences
- Material handling
- Metal working machines
- Military
- Nuclear

- Oil industry
- Packaging
- Quality assurance inspection
- Security
- Testing and metrology
- Wood working machines



And more

A few applications using SmartMotor™ technology:

- Anode wire welding
- Automatic Web tensioning/alignment
- Auto-progression adjusting parts indexers
- Bearing inserters/presses
- Capacitor manufacturing
- Cappers
- Centrifuges
- Compression/tension testing
- Coordinate measuring machines
- Cut-to-length gage stops
- Dashboard controls button/switch testers
- Destructive testing
- Dicers
- Fillers
- Gimble mount accelerometer testing
- Glass tube cutting
- Glue dispensers
- GPS guided steering/drive control
- High speed indexing labelers
- Hydroelectric turbine nozzle control
- Infeed/outfeed stackers
- Manual handwheel over-ride
- Nut/bolt/screw drivers
- Pan & tilt bases
- Paper feeders/folders
- Parts redirectors
- Phase gearhead adjusting
- Pick & place palletizers
- Positive displacement pumps
- Shock load testing
- Step/tapered spool winders
- Tactile switch testing
- Tire tread grinding
- Topographical mapping
- Transformer coil winders
- Turbine blasé grinding
- Vision inspection
- Voice coil winders
- Wafer handlers
- Web guide
- Web tensioning
- Wire bonding
- and more

Case Studies

Animatics' case studies titled "Textbook Applications, Innovative Solutions" showcase just a few of the many success stories featuring the SmartMotor™ and other Animatics products. For more information, and to get the whole story, visit www.animatics.com.

Synchronized Control of Vertical Loads

The Animatics SmartMotor was integral in the production of 1,008 flying spheres at The World Expo in Shanghai, China. Partnering with entertainment automation company Fisher Technical Services, LLC, the SmartMotor™ servos were attached to each of the 1,008 spheres and fashioned to raise and lower in quick, smooth succession over a large grid suspended above a stage. The Class 5 SmartMotor was able to provide Contouring Mode at data packet rates fast enough to allow for the fluid movement of all components of the performance. The result was a breathtaking kinetic sculpture that looked more like a computer generated animation than a life-size production.

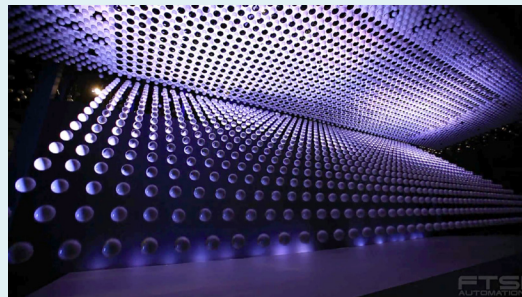

Precision Positioning System

In an environment that hardly favors stability of a Camera, Burchfield Automation recruited the help of Animatics to fit a video Camera onto a jarring ATV travelling rough terrain. Animatics used the Phase Offset feature of their Class 5 SmartMotor™ in order to dampen the vibration of the Pan & Tilt system and allow the Camera to stay focused on the horizon as the vehicle raced through hills and troughs. The Phase Offset option creates a differential velocity between the external gyroscopic measurement of the Pan & Tilt system and the motor's internal encoder, which allows the physical measurement of the gyroscopic position sensors to tie in directly with the closed loop of the servo.



An example of Burchfield Automation's Pan & Tilt system that is used in various industries

CNC Surfboard Shaper

Compact, rugged and low maintenance. That is what OEM Dynamics' (division of Animatics) HLD60-H3 linear actuator is, and that is the kind of machine Precision Shapes Northwest created using it. Typical surfboard shaping machines are large, incredibly heavy and much too expensive. With the HLD60-H3 and Animatics JenCNC™ software, they combined both a CAD/Cam and motion control software package into a unique graphical user interface to control multiple SmartMotor servos on the linear motion systems in true 3-D coordinated motion. The machine went to market in record time and the results were in the profits.



See the video of this Application on www.animatics.com



See more @ www.animatics.com

Example Applications

OVERVIEW
MOTOR SPECIFICATIONS
LINEAR SYSTEMS
CONNECTIVITY
PERIPHERALS
IP 65 MODELS & CONNECTIVITY
POWER SUPPLIES & SHUNTS
GEAR HEADS
SOFTWARE
APPENDIX

Concepts and Capabilities of the Animatics Product Range:

Programmable Rotary Index Table

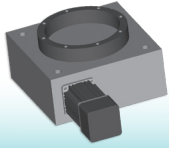

Modulo Position Mode

- Biomedical
- Oil Industry
- Semiconductor
- Chemical Coatings
- Cryogenics

Centrifugal applications, destructive and g-force testing, paint mixing and manufacturing, oil separation & mfg., anode wire welding, etc.

By adding a SmartMotor to any servo-rated worm gear box or flange output gear reducer, the system becomes a fully programmable rotary index table and can be programmed to any practical number of indexes and dwell times. Given the I/O and control capabilities, the dwells can be based on end-of-process contrary to fixed mechanical CAM, speeding up overall production cycle times.

3-Position Parts Diverter

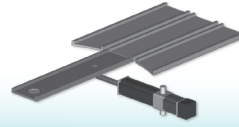

Position Mode

BCD Input

Absolute Position Mode

- Packaging
- Material Handling
- Food and Beverage
- Agricultural
- Chemical
- Medical

Product separation for mid production, package diverting, grouping and ungrouping, product inspection and diverting

A simple upgrade to a SmartMotor from a two or three position pneumatic air cylinder allows multi-point programmable positioning while maintaining I/O trigger control from any PLC.

Traverse & Take-up Spool Winders

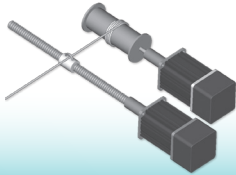

Velocity Mode & Electronic Gearing Summed Together

- Textile or other engineered fibers
- Transformer Mfg.
- Audio Electronics
- Tank Mfg.
- Motor Mfg.

Spooling/winding yarn, thread, carbon fiber, or other converted material, voice coil winders, musical instrument cord, wire and string production

Using programmable software travel limits, electronic gearing, and special firmware drive control, winders can work with unlimited variations of spool width, wind angle and end-point dwell as well as step, stack and tapered winding applications. SmartMotor's low inertia and high speed acceleration enable extremely precise winding.

Multi-Axis Pick & Place



Position Mode

Absolute Position Mode

- Automotive
- Semiconductor
- Packaging
- Material Handling
- Biomedical
- Food and Beverage

Product packaging, wafer processing, hazardous material handling, liquid filling applications, capping applications, palletizing machines

Up to 120 individually addressed motors can be placed on a communications bus allowing for easy coordination of multiple axis applications.

Drill & Tap/Nut Runner

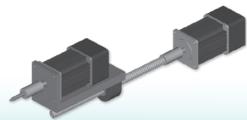

Follow Mode with Velocity Mode and Monitoring Position Error

- Automotive
- General Fabrication
- Machining
- Aerospace

Dashboard control button/switch testing, eyeglass mfg., any operation requiring drilling, tapping or screw feed.

Set a rotating SmartMotor as the Master and have the linear axis electronically gear off of it to provide high speed drilling and tapping and screw feed control with limited torque. Adding proper torque detection, the unit can detect when the screw or tap has become dull or worn. As a nut/screw runner, it can detect cross thread, broken or stripped thread, or missing or jammed parts.

Input/Output Stacker



Position Mode

Absolute Position Mode

Relative Position Mode

- Semiconductor
- Food and Beverage
- Consumer Electronics
- Consumer Goods

Compact disk mfg., wafer processing, pizza or tortilla stacking, flatware and dishware production, etc.

Start stacking and continue in incremental stack shifts while maintaining part counts. Having localized I/O within the integrated controls, all parts handling can be dealt with by the stack motor itself.

Print & Die Cut Alignment

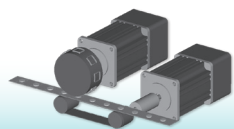

Follow Mode with Phase Offset Electronic Gearing

- Metal Working
- Consumer Goods
- Packaging
- Government
- Any industry that labels their products

Puzzle piece production, product label die cutting & blister pack sealing, printing, scrapbooking piece production, leather die cutting for consumer products, jewelry stamping, metal embossing, stencil making, stamp and adhesive precision layer cutting, etc.

With electronic gearing, you can accomplish phase offset moves to properly align die cut processes with printed registration marks. The same technique can ensure over-mold and multi-layer print alignment and pocketed blister pack parts placement.

Programmable Cut-to-Length Stop or Back Stop Gage

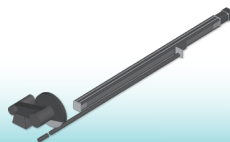

Index with Position Mode

- Biomedical
- Industrial Mfg.
- Chemical
- Construction

Glass tube cutting, precision pipe cutting, trim finishing, framing, window mfg., etc.

With the ability to program up to 1,000 subroutines and 32K of extra storage space, the system can be programmed for hundreds of back stop positions and sequences. You only need a simple HMI; no PLC or PC is required.

Process Tension Control (with one or multiple nip rollers)

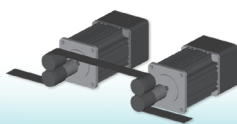

Follow Mode with Phase Offset

- Packaging
- Consumer Goods
- Paper
- Material Handling
- Consumer Electronics

Package labeling, lateral position control, paper processing, film and foil processing, converted materials mfg.

Using phase offset moves while electronically gearing Master to Slave, you can easily control tension between two sets of nip rollers. Tension is regulated by pre-test measurement or live analog, serial or digital feedback even with varying speeds and up or downstream loads.

Programmable Force Press to Fit



Position Mode with Derivative Error Control

- Medical
- Military
- Computer
- Automotive Production
- Wine and Spirits
- Consumer Products
- Cell Phone Mfg.

Resistive welding, power tool production, computer hardware mfg., bottle corking, medical device mfg., toy production, consumer electronics production, any general capping applications.

A SmartMotor allows for closely regulated positioning and position error control. This results in highly repeatable torque limited machine cycles. The result is a very good solution for pressing parts together or any other force-limited application where both cycle time and proper force must be tightly regulated.

Parallel Axis Gantry

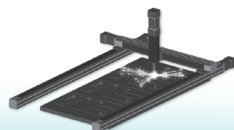

Position Mode with Contouring Mode

- Automotive
- Government
- Military
- Metal Working
- Wood Working
- Aerospace
- Marine Sciences

Glue dispensing, coordinate measurement, topographical mapping, CNC wood or metal cutting, many other CNC operations.

Proper fault handling will prevent gantry racking in the event that either Master or Slave faults out during a move. Homing is done only once during power-up and the Master and Slave sync up all times after maintaining perfect alignment. Works perfectly with Animatics' CNC software.

High Speed Parts Counter & Verification

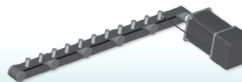

Velocity Mode or Follow Mode with High Speed Counter Input

- Medical
- Chemical
- Materials Handling
- Consumer Goods Mfg.
- Government
- Military
- Quality Inspection

Pharmaceutical container filling, quality control, RFID tag mfg., battery mfg., office chair wheel processing, cabinetry knob counting, currency and coin production, ammunition mfg., any high-speed part inspection process.

The external encoder input can be used to read quadrature incremental encoders, step and direction input or just as a counter where input pulses can be counted at a rate of up to 2 Megahertz. As a result, the motor can feed parts and part count even at high speed and with little distance between each part.

Total Benefits of Integrated Motion Control

OVERVIEW

The Conventional Servo System in Machine Design Projects

Development Time

- Several weeks designing physical control cabinets
- Time spent interfacing with multiple vendors
- Several weeks programming PLCs
- Weeks designing/installing cabling
- Several days interfacing motors
- Time interfacing I/O points



Total: 4-6 months

The Simplicity of the Animatics SmartMotor™ in Machine Design Projects

Development Time

- Full control electronics integrated in motor
- One stop shopping with excellent lead-times
- PC based programming environment. Program is developed & stored in any motor's internal memory
- Plug and play off-the-shelf cables compatible with all SmartMotors, and existing legacy components
- 7 on board A-D I/O, option for 10 additional (24V) on board



Total: 1.5 months or less

MOTOR SPECIFICATIONS

LINEAR SYSTEMS

CONNECTIVITY

PERIPHERALS

IP 65 MODELS & CONNECTIVITY

POWER SUPPLIES & SHUNTS

GEAR HEADS

SOFTWARE

APPENDIX

Design & Procurement Costs

- Control cabinet, rails, mounts
- PLCs
- Control modules
- Electronic amplifiers
- A-D I/O converters
- Motors
- Encoders
- Cabling

Total: \$\$

Design & Procurement Costs

- SmartMotor™
- Power Supplies
- Cabling
- Development/programming software **FREE**

Lowest Total Cost!

Total: \$

Maintenance/Support (Downtime Losses)

Troubleshooting:

- Programming non-localization & non-uniformity
- Multiple vendors
- Excessive cabling
- Need for multiple engineers/technicians
- Numerous potential failure points

Reliability Factors:

- MTBF is function of machine component count
- Non-standardization of components causes communication errors
- Having numerous systems and subsystems reduce reliability

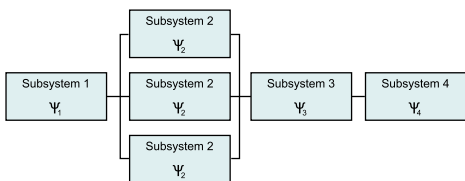

Total:

Maintenance/Support

- All debugging of I/O done at SmartMotor; it reads the analog value of every I/O point regardless of how it is configured
- The SmartMotor software program can check for short circuits, failed outputs, read bus voltage, and check temperature
- Machine builder can specify the appropriate SmartMotor configuration and develop a special part number for future use
- Motion control programs can be standardized and stored in every SmartMotor. A network of SmartMotors can be controlled to use only specific parts of programs
- A spare SmartMotor can be kept on hand and substituted in the case of failure, minimizing downtime. **ZERO DOWNTIME ACHIEVABLE**
- SmartMotors have an extremely long MTBF, and exceptionally low rate of failure

Total: **(Zero Downtime Achievable)**

Total Benefits of Integrated Motion Control

The Conventional Servo System in Machine Design Projects

Flexibility and Expansion

- Large cabinets with complex wiring diagrams are difficult to expand or modify
- Multiple vendors cause inconsistencies in future machine modifications
- Machine expansion is difficult with larger cabinet-based systems; thereby hindering growth

Total: 

The Simplicity of the Animatics SmartMotor™ in Machine Design Projects

Flexibility and Expansion

- Wiring is a cinch with plug and play components
- One stop solution with full technical support, programming tutorials, training sessions and more
- Animatics' Automation Solution Providers are available around the world and whenever you decide to expand your business

Total:  **Extreme Flexibility!**

Sustainability

- More components demand more energy from the entire machine

Total: 

Sustainability

- Smaller initial footprint leaves more space available for other machines or future machine development.
- Less power consumption
- SmartMotor's compact packaging reduces waste energy and material during production

Total:  **SMART!**

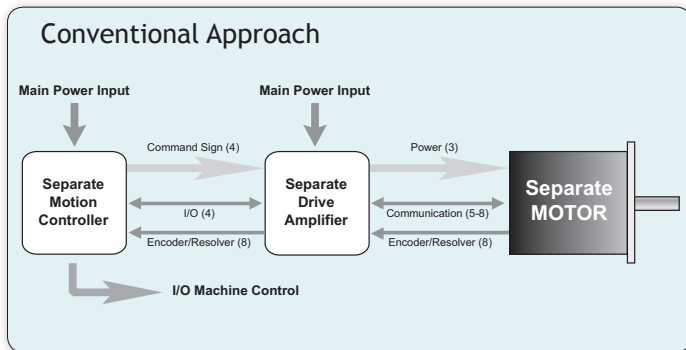

Control cabinet of complex cables, rails and mounts wastes valuable time, energy and money

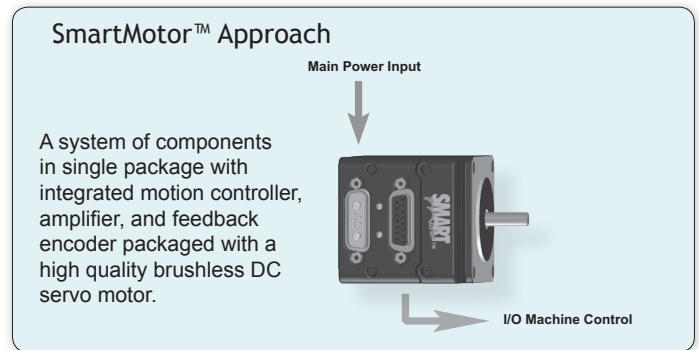
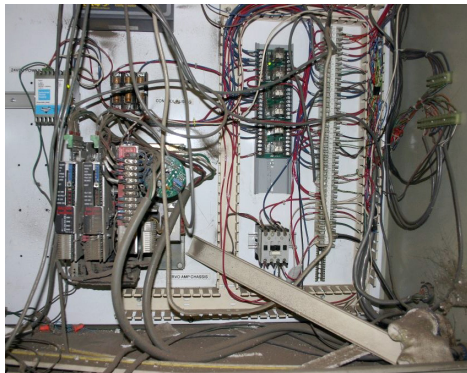

Simple connection map for the SmartMotor

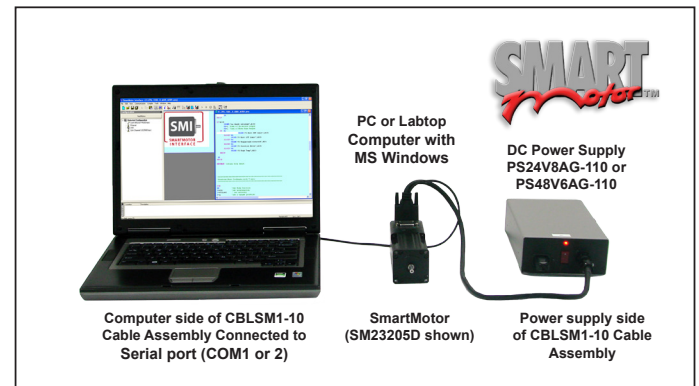

Unparalleled Power Density

Shown below is a scaled comparison of an SM23165DT and a competitive integrated solution.

The SM23165DT has a continuous output power of ~200Watts at 3800RPM. The competitive integrated solution is rated at 75Watts at 3000RPM.

This shows a stark contrast to the compactness and efficiency of the Animatics SmartMotor technology.

For any given servo drive amplifier, with higher current demands, more heat will be generated.

SmartMotor™ has the lowest thermal heat up of any conventional or integrated package on the market. Less surface area is required to dissipate heat resulting in a more compact design. No fans, no large heat sinks! Multi-axis machines become more compact. Power consumption is reduced as well resulting in lower operating cost.

Motors are shown to scale with each other

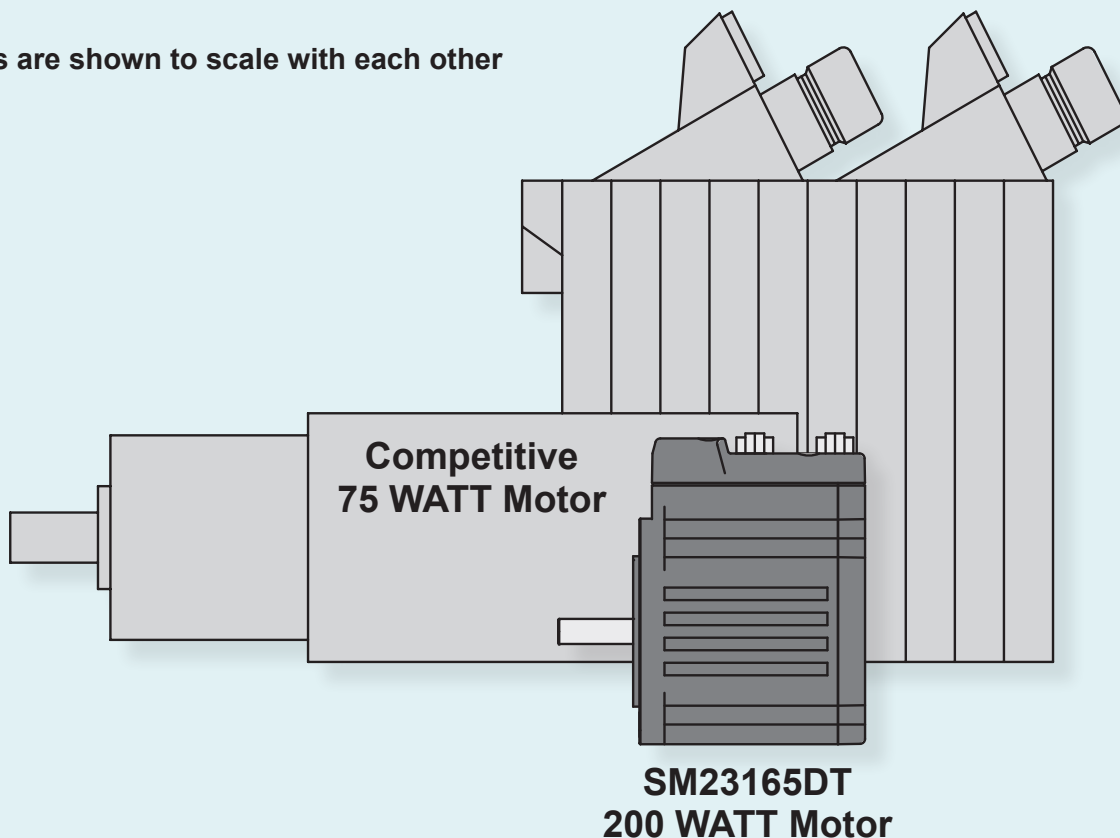

Understanding Part Numbers

Animatics Class 5 SmartMotor™ Part Numbering Guidelines

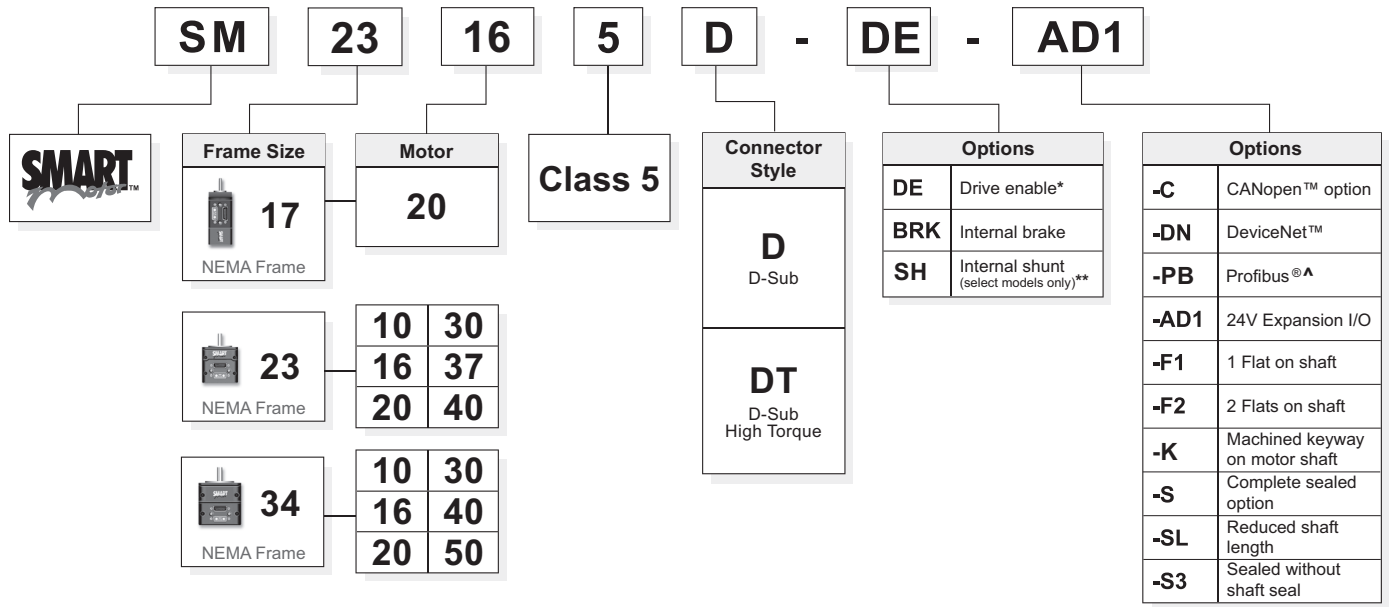

* Separate drive & control power

^A Profibus option only available on SM23165D & SM23165DT and SM34165D & DT products and without brake or 24V I/O

** SM34165D & SM34165DT are the only models that can have an internal shunt.

Animatics Class 5 SmartMotor™ Available Option Combinations

NEMA 17 FRAME	BRAKE	24V I/O	CAN bus
	-BRK	-AD1	-C or -DN
SM17205D			•
		•	
		•	•
	•		

NEMA 34 FRAME	BRAKE	24V I/O	CAN bus
	-BRK	-AD1	-C or -DN
SM34165D**			•
SM34165DT**		•	
SM34105D		•	•
SM34205D	•		
SM34305D	•	•	•
SM34405D	•	•	•

**SM34165D & SM34165DT are the only models that can have an internal shunt.

NEMA 23 FRAME	BRAKE	24V I/O	CAN bus
	-BRK	-AD1	-C or -DN
SM23165D			•
SM23165DT		•	•
	•		
SM23375D			•
SM23375DT		•	
SM23105D		•	•
SM23205D	•		
SM23305D	•	•	•
SM23405D	•	•	•

For an overview of all our products, visit: www.animatics.com



CANopen

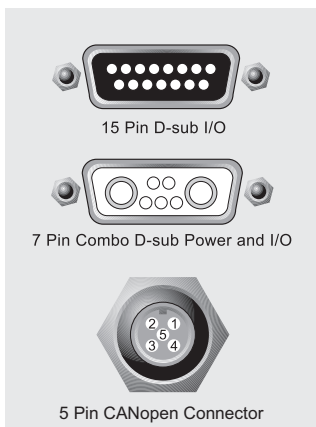

CANopen Pinout:

- 1 Not Connected
- 2 Not Connected
- 3 CAN ground
- 4 CAN H
- 5 CAN L

Animatics CANopen SmartMotor™

Features Include:

- All basic Motion commands available via CiA V4.02 specification
- Ability to read/write all SmartMotor variables
- Use of onboard I/O via CANopen Gateway, SmartMotor program, or RS232 commands
- Ability to run 1000 SmartMotor subroutines via CANopen
- Online diagnostics of the SmartMotor™ via SMI2 software and RS232 connection
- Up to 127 nodes
- 250 micro second interrupt driven subroutine
- Baud Rates: 20K, 50K, 125K, 250K, 500K, 1Mbps default 125Kbps



Note: This option DOES NOT apply to all Models, please see comparison chart on center foldout for availability.

DeviceNet™

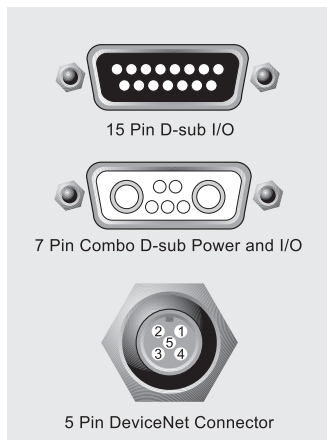

DeviceNet Pinout:

- 1 Not Connected
- 2 +24V
- 3 Common
- 4 CAN H
- 5 CAN L



Animatics DeviceNet SmartMotor™

Features Include:

- Polled I/O and Explicit Messages from your PLC to control all SmartMotor™ operation
- Read/Write control over all ODVA Position Controller parameters
- Use of onboard I/O via DeviceNet, SmartMotor™ program, or RS232 commands
- Ability to run 1000 SmartMotor subroutines via DeviceNet and read/write four 32-bit user variables
- Online diagnostics of the SmartMotors via SMI2 software and RS232 connection
- Up to 64 DeviceNet nodes
- 250 micro second interrupt driven subroutine
- Baud Rates: 125K, 250K, 500K, 1Mbps default 125Kbps



Note: This option DOES NOT apply to all Models, please see comparison chart on center foldout for availability.

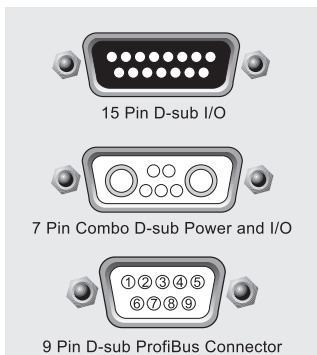

Profibus Pinout:

1	NC	6	+5V
2	NC	7	NC
3	BUS-B	8	BUS-A
4	NC	9	NC
5	ground		

Animatics Profibus SmartMotor™

Features Include:

- Command/Response Codes for all Class 5 SmartMotor commands
- Use of onboard I/O via Profibus, SmartMotor program, or RS232 commands
- Ability to run 1000 SmartMotor™ subroutines via Profibus
- Ability to read/write all SmartMotor variables
- Online diagnostics of the SmartMotors via SMI2 software and RS232 connection
- Up to 127 Profibus nodes
- 250 micro second interrupt driven subroutine
- Baud Rates: default 1.5Mbps
9.6, 19.2, 31.25, 45.45, 93.75, 187.5, 500 kbps,
1.5, 3, 6, 12 Mbps

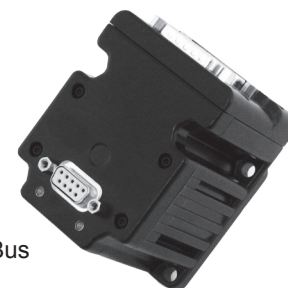

Note: Profibus baud rates are achievable only with proper cable length and termination connectors. The minimum cable length when operating ≥ 1 MBaud is 1 meter (3 feet). If the cable is too short, reflected impedance can cause loss of communications data packets and spurious node errors.

HIGHLY RECOMMENDED OPTION. PLEASE READ!

Hardware "DE" Option:

The DE option allows the controller and drive-amplifier to be powered from separate 24-48 VDC power supplies.

- Controller can be powered from a standard 24 VDC supply
- **Position will not be lost on loss-of-drive-power**
- **No need to re-home**
- Load surges will not cause power surge on controller
- Standard battery options are made simpler

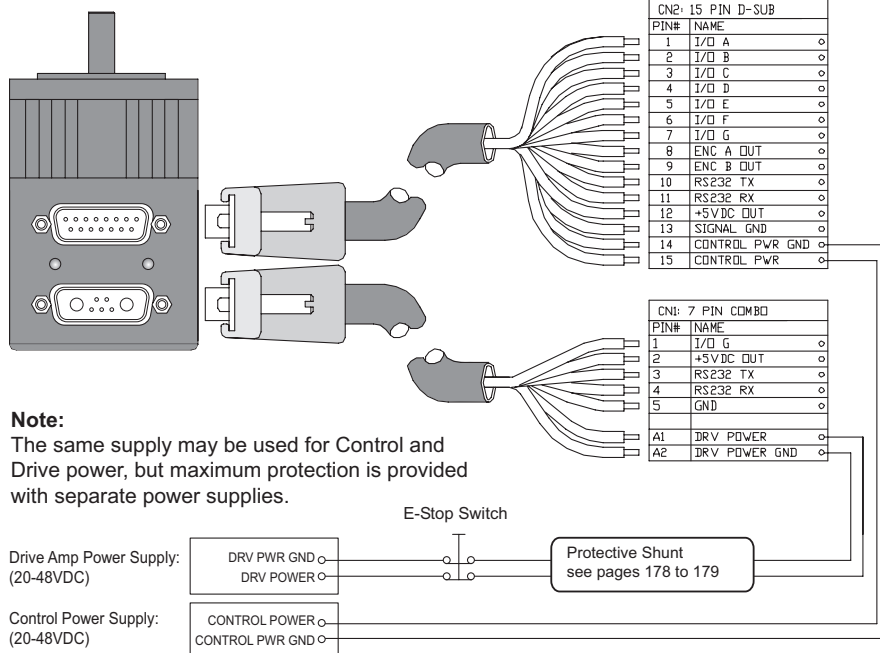

Note: All IP sealed SmartMotors are designed to always have separate drive and control power. As a result, no DE designation is available for IP sealed SmartMotors. Control power on IP sealed SmartMotors is rated for 24VDC, maximum of 32VDC.

Understanding Animatics Torque Curves

Each set of torque curves depicts limits of both continuous and peak torque for the given SmartMotor™ over their full range speed.

Peak Torque Curve:

The peak torque curve is derived from dyno testing and is the point at which peak current limit hardware settings of the drive prevent further torque in an effort to protect drive stage components.

Continuous Torque Curve:

The continuous torque curve is also derived from dyno testing, but is instead the point at which the temperature rises from an ambient of 25°C to the designed thermal limit.

For example, the motor will be placed on the dyno tester and set to operate at 1000 RPM continuously with the load slowly increased until the controller reaches its maximum sustained thermal limit. This limit is either 70°C or 85°C depending on the model number. All Class 5 SmartMotor Servos are set to 85°C.

The far lower right side of the curve is limited by supply voltage. This is the point at which Back EMF suppresses any further speed increase. Higher supply voltages will shift the zero torque point of the curves further to the right.

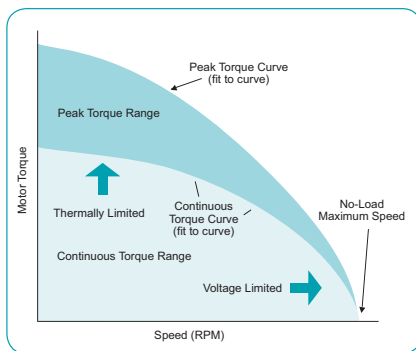

Ambient Temperature Effects on Torque Curves and Motor Response:

If the motor is operated in an environment greater than 25°C, then it will reach its thermal limit faster for the same given load thereby further limiting continuous torque.

Therefore; any given motor torque curve MUST BE linearly de-rated for a given ambient temperature from 25°C to 85°C for all Class 5 SmartMotor Servos.

Supply Voltage Effects on Torque Curves and Motor Response:

Higher voltages have two-fold effects on torque curves. As mentioned above, raising voltage will shift the curve to the right. It will also allow higher current into the drive. However, Torque curves depict Torque at a given velocity.

If you double supply voltage, the motor can sustain twice the original velocity. But since acceleration is the differential of velocity, it can achieve 4 times the original acceleration. This is useful for high speed indexing and fast start/stop motion.

All Torque Curves in this catalog also have SHAFT OUTPUT Power Curves overlaid on them as well.

Power can be found by the following equation:

$$\text{Power (kW)} = \text{Torque (N.m)} \times \text{Speed (RPM)} / 9.5488$$

For any given mechanical system being moved by a SmartMotor™, it is ideal to ensure the motor is running within its optimum performance range. This can be achieved via proper mechanical system design by adjusting one of the following as it may apply:

- Gear Reduction
- Belt Reduction
- Lead Screw Pitch
- Pinion Gear diameter

Example 1: (Rotary Application)

Suppose you have a load that requires 300 RPM at the output of a gear head. Suppose the optimum speed range for the motor is 2100 RPM.

Divide the optimum operating speed by the load speed to get the ideal gear reduction. In this case : 2100 RPM / 300 RPM=7. So a 7:1 gear reduction would allow the motor to operate in its most efficient range.

Example 2 (Linear Application)

Suppose you need to run at 100mm/second via a ball screw and the motor has an ideal range of 3000 RPM. 3000 RPM/60= 50 Rotations per second. 100mm/sec divided by 50RPS is 2mm per rotation.

So an ideal pitch would be 2mm.

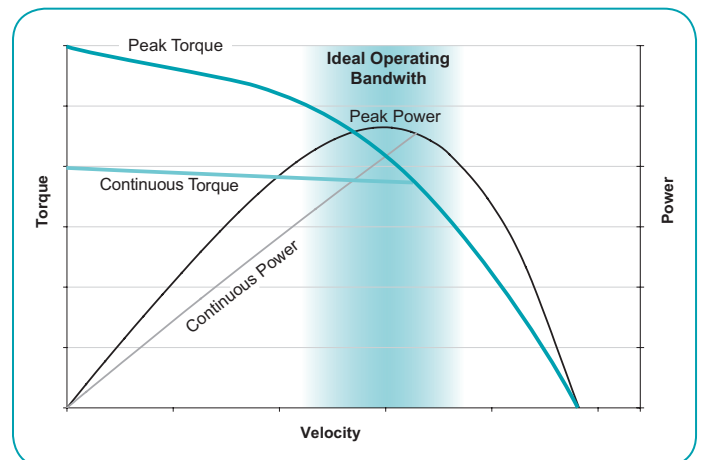

Considerations when using torque curves for motor sizing:

For any given product model number, there may be variations of as much as +/-10%.

The following diagram depicts data points collected from dyno testing of a given model motor. A best-fit torque curve is created from these data points and is then de-rated to at least 5% below the worst case data points. The de-rated curve is what is advertised. This means that within any given model number, EVERY motor sold will perform at or better than the advertised torque. Theoretically, ALL motors should be no less than 5% better than advertised and may be better than 20% higher.

The diagram shows motor loading in 4 areas.

- 1 This is ideal and depicts a load within the normal operating range of the motor. The motor should operate well and have no problems for many years.
- 2 The load is very close to the operating limit. The motor will run quite warm as compared to Point 1.
- 3 The load exceeds the advertised level and exceeds +10% expected range of possible torque capabilities. In this case, the motor will most likely either overheat quickly and fault out or immediately get a position error because it simply does not have enough power to support the load demand.

WARNING

- 4 The load exceeds the advertised operating limit of the motor. However, due to data scatter and de-rating, there may be some motors that will work and others that do not.

Why? Because it is in the area of +/-10% variation expected in motors for a given size. This can become a major problem. Imagine designing a machine that operates in this range. Then you replicate that machine with many of them running on a production floor. One day, a motor at the lower end of the +/-10% expected variation would be placed on a new machine and that motor would get spurious drive faults. It would appear as though the motor is malfunctioning because... "all the other motors work just fine". This is unfortunate because, in reality, all motors were undersized and operating outside of their advertised limits.

This is why it is important to properly calculate load torque to ensure the correct motor is designed into the application. Never assume that without proper load calculation and motor sizing, that testing of one motor means all of that size may work. This is simply not the case. **Try to keep operating conditions below the advertised limits to ensure reliable long-life operation.**

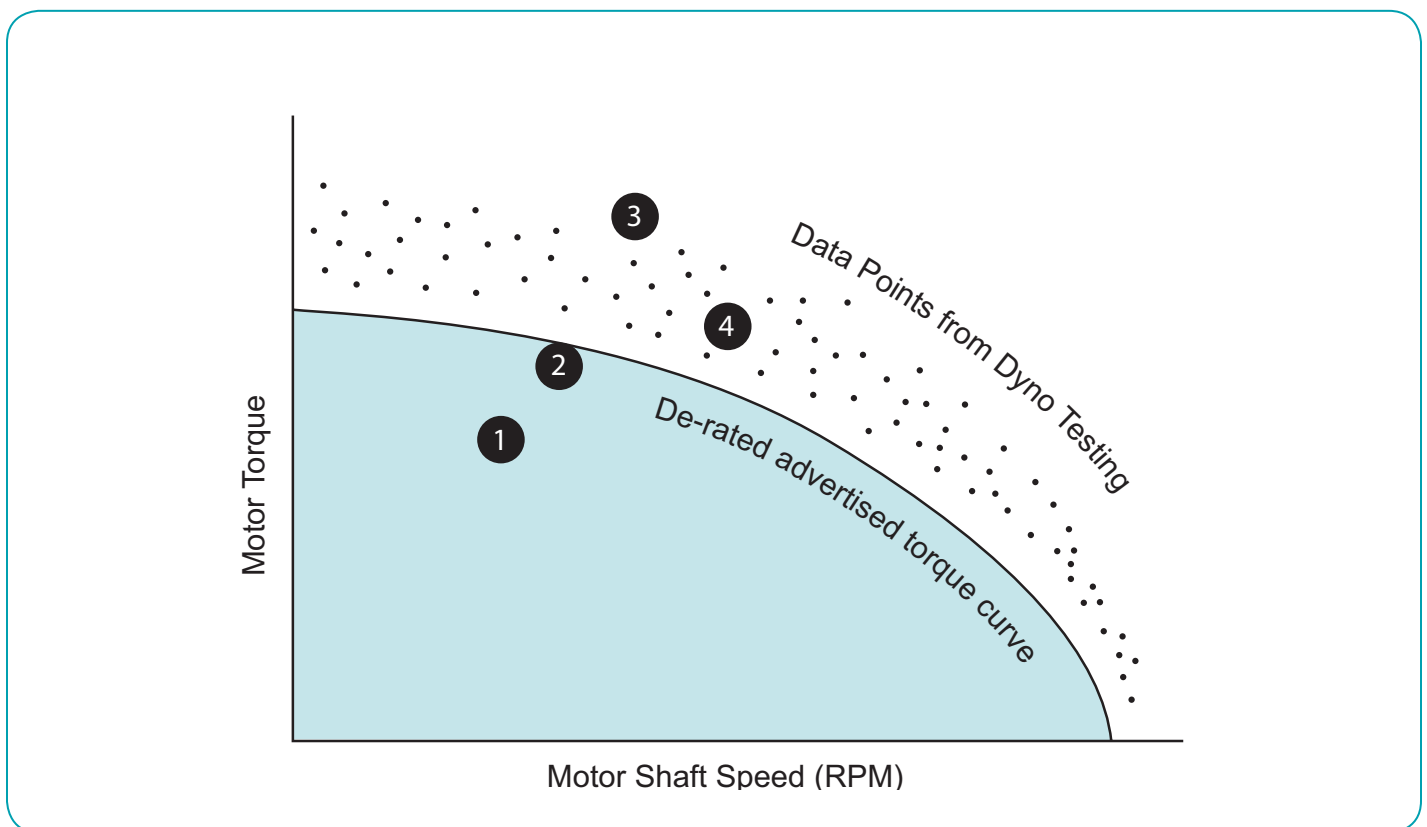

OVERVIEW
MOTOR SPECIFICATIONS
LINEAR SYSTEMS
CONNECTIVITY
PERIPHERALS
IP 65 MODELS & CONNECTIVITY
POWER SUPPLIES & SHUNTS
GEAR HEADS
SOFTWARE
APPENDIX

SM17205D		
Continuous Torque	2.08	in-lb
	33	oz-in
	0.24	N-m
Peak Torque	3.82	in-lb
	61	oz-in
	0.43	N-m
Nominal Continuous Power	145	Watt
No Load Speed	7,900	RPM
Continuous Current @ Nominal Power	4.5	Amps
Voltage Constant	5.5	V/kRPM
Winding Resistance	1.8	ohms
Encoder Resolution	4,000	Counts/Rev
Rotor Inertia	0.00026	oz-in-sec ²
	0.184	10 ⁻⁵ Kg-m ²
Weight	1.2	lb
	0.55	kg
Shaft Diameter	0.197	in
	5.00	mm
Shaft, Radial Load	7	lb
	3.18	kg
Shaft, Axial Thrust Load	3	lb
	1.36	kg
DeviceNet Available	Yes	
Profibus Available		
CANopen Available	Yes	



Animatics SmartMotor™ SM17205D (No Options) CAD Drawing

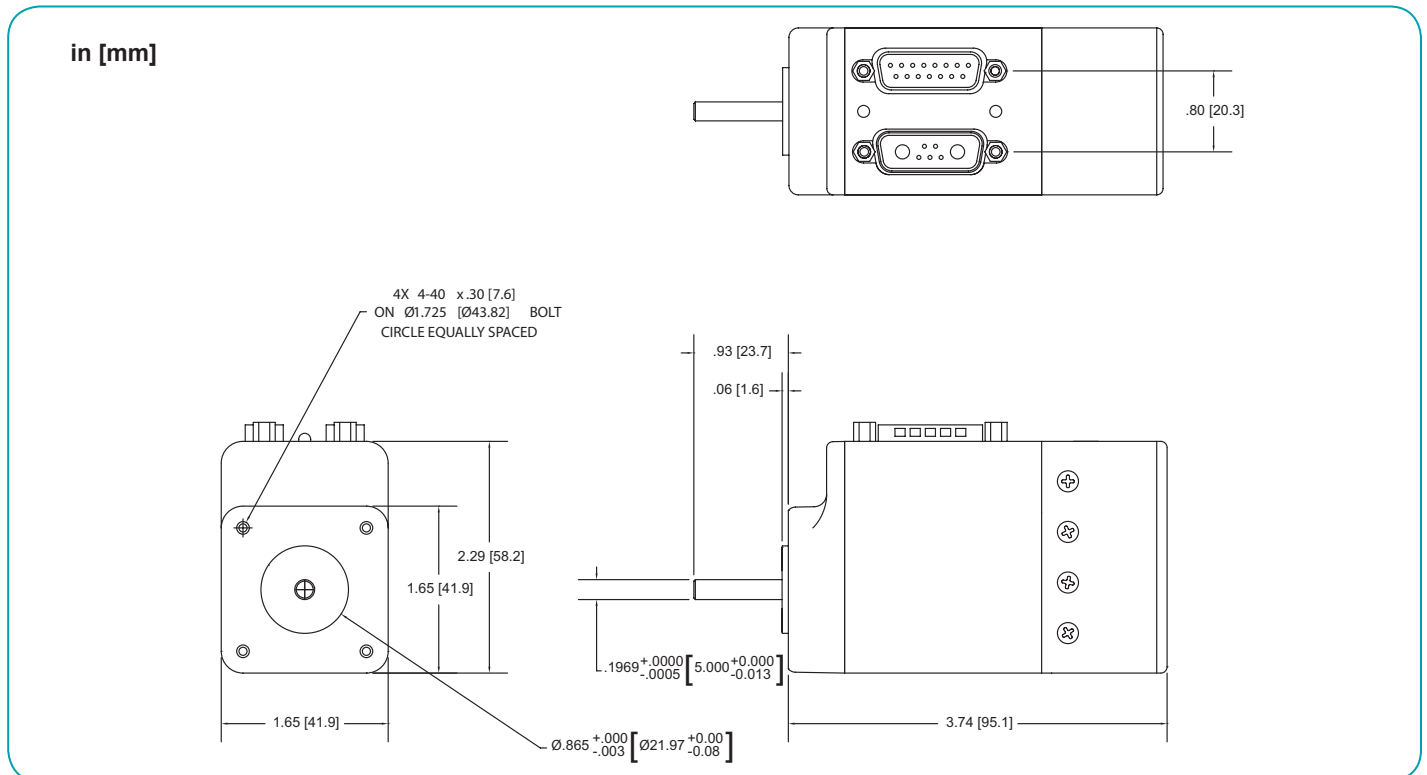

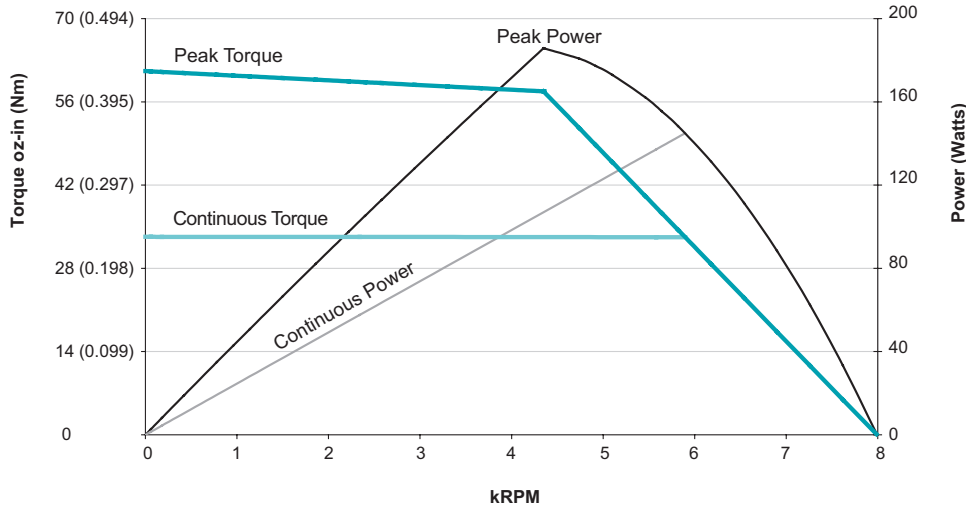

**SM17205D
at 48 VDC
at rise to 85°C**

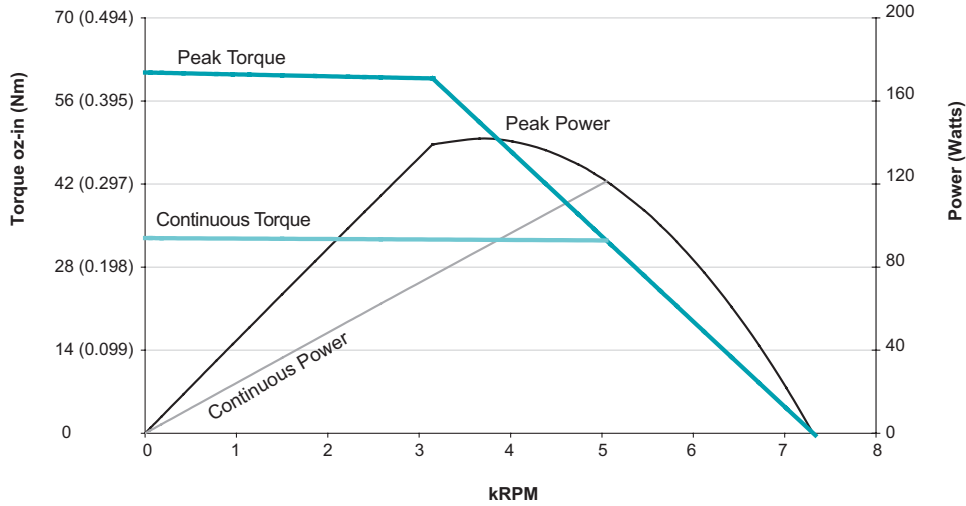

**SM17205D
at 42 VDC
at rise to 85°C**

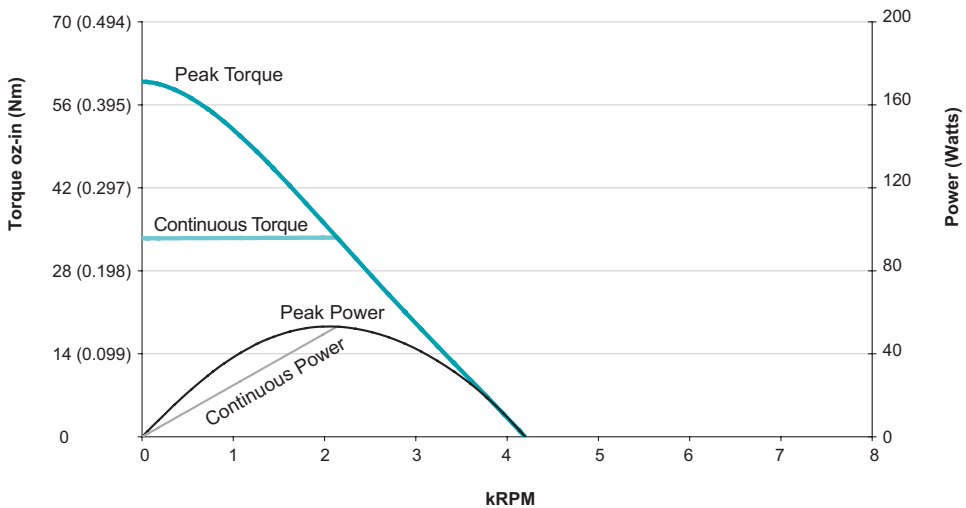

**SM17205D
at 24 VDC
at rise to 85°C**

All Torque curves based on 25°C ambient.
Motors were operated in Trap-Commutation Mode.
Please consult factory for Sine-Commutation Torque Curves.

OVERVIEW
MOTOR SPECIFICATIONS
LINEAR SYSTEMS
CONNECTIVITY
PERIPHERALS
IP 65 MODELS & CONNECTIVITY
POWER SUPPLIES & SHUNTS
GEAR HEADS
SOFTWARE
APPENDIX

SM23165D		
Continuous Torque	2.50	in-lb
	40	oz-in
	0.28	N-m
Peak Torque	4.00	in-lb
	64	oz-in
	0.45	N-m
Nominal Continuous Power	181	Watt
No Load Speed	10,400	RPM
Continuous Current @ Nominal Power	5.0	Amps
Voltage Constant	4.45	V/kRPM
Winding Resistance	1.0	ohms
Encoder Resolution	4,000	Counts/Rev
Rotor Inertia	0.00099	oz-in-sec ²
	0.699	10 ⁻⁶ Kg-m ²
Weight	1.0	lb
	0.45	kg
Shaft Diameter	0.250	in
	6.35	mm
Shaft, Radial Load	7	lb
	3.18	kg
Shaft, Axial Thrust Load	3	lb
	1.36	kg
DeviceNet Available	Yes	
ProfiBus Available	Yes	
CANopen Available	Yes	

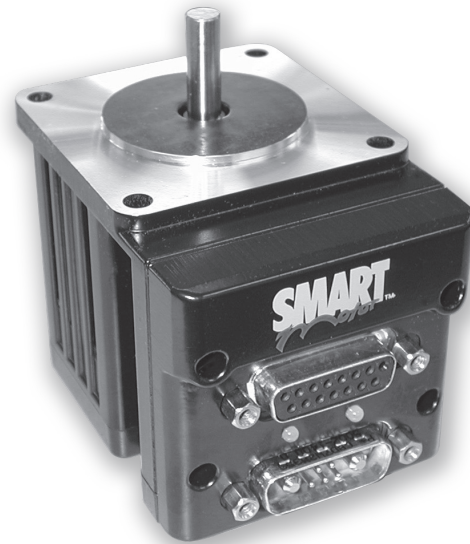

Animatics SmartMotor™ SM23165D (No Options) CAD Drawing

in [mm]

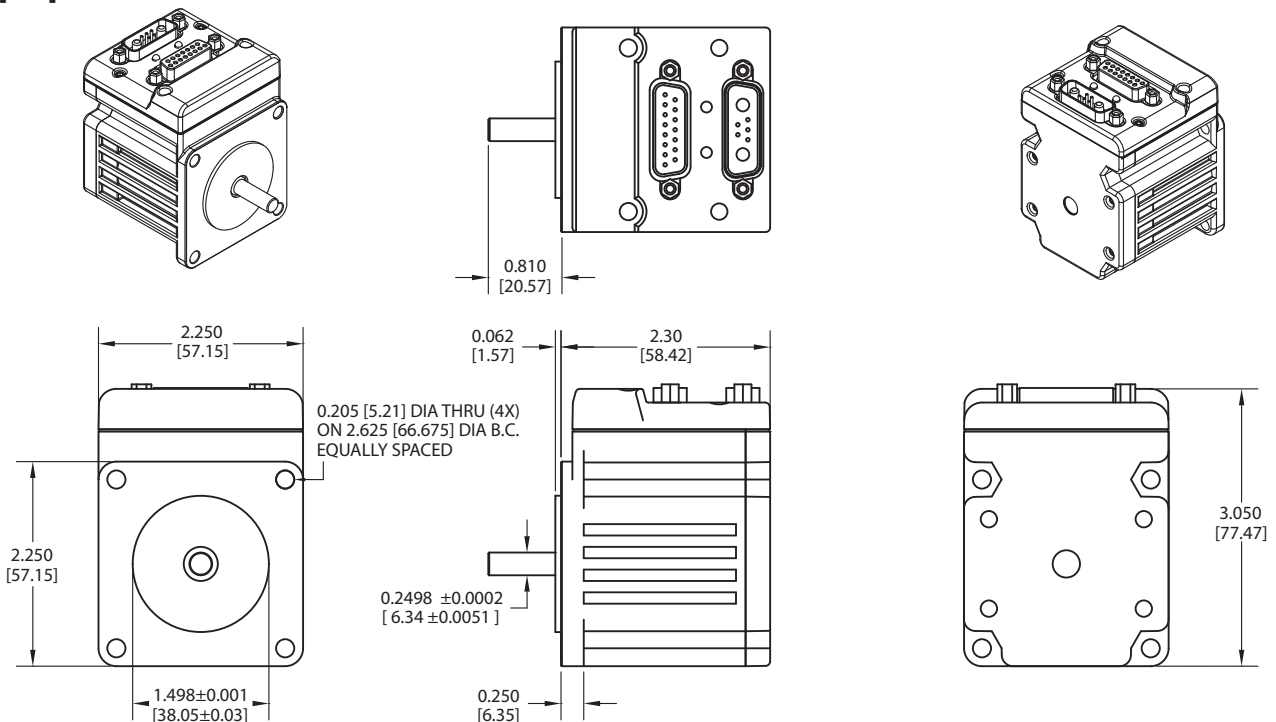

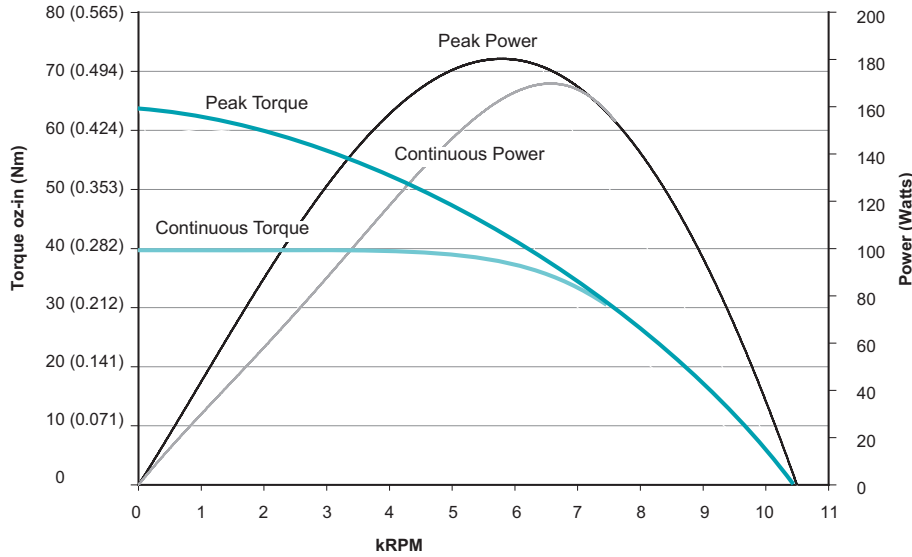

**SM23165D
at 48 VDC
at rise to 85°C**

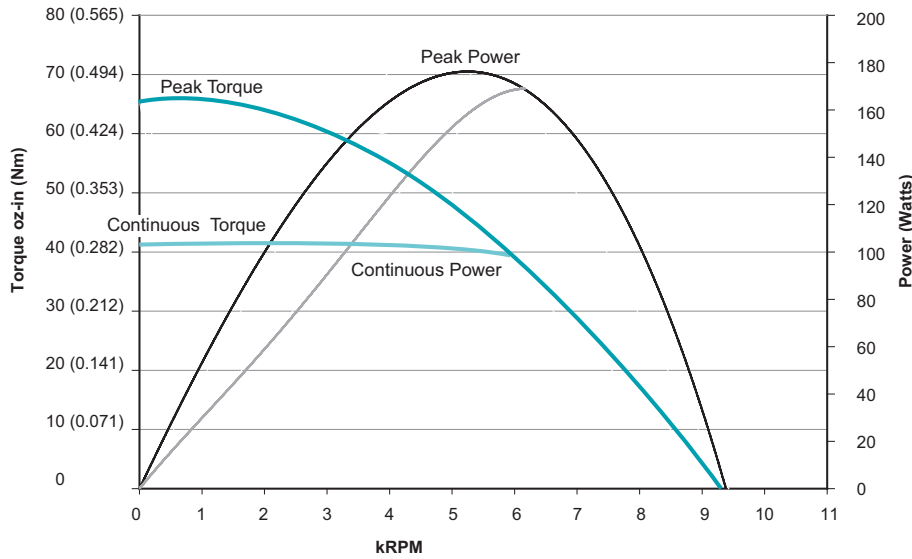

**SM23165D
at 42 VDC
at rise to 85°C**

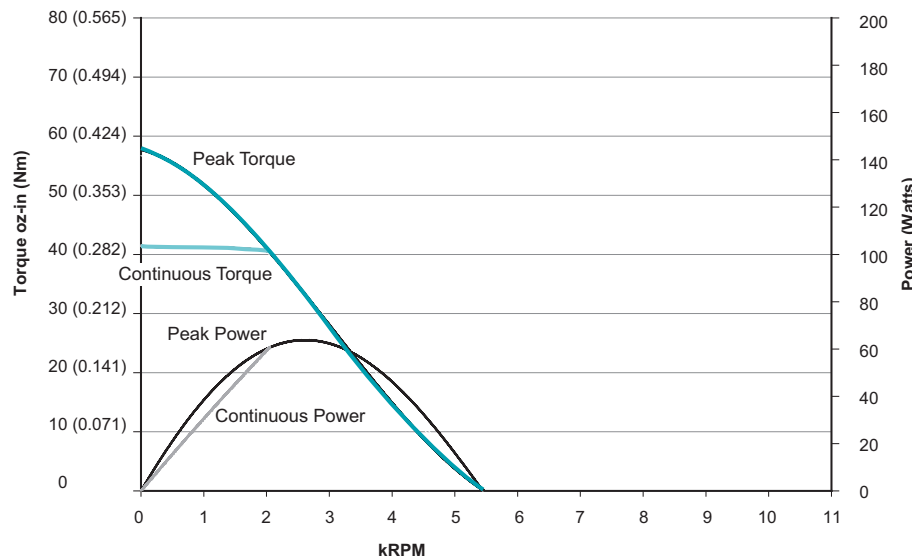

**SM23165D
at 24 VDC
at rise to 85°C**

All Torque curves based on 25°C ambient.
Motors were operated in Trap-Commutation Mode.
Please consult factory for Sine-Commutation Torque Curves.

OVERVIEW
MOTOR SPECIFICATIONS
LINEAR SYSTEMS
CONNECTIVITY
PERIPHERALS
IP 65 MODELS & CONNECTIVITY
POWER SUPPLIES & SHUNTS
GEAR HEADS
SOFTWARE
APPENDIX

SM23165DT		
Continuous Torque	4.61	in-lb
	74	oz-in
	0.52	N-m
Peak Torque	7.40	in-lb
	118	oz-in
	0.84	N-m
Nominal Continuous Power	204	Watt
No Load Speed	5,200	RPM
Continuous Current @ Nominal Power	6.1	Amps
Voltage Constant	9.08	V/kRPM
Winding Resistance	0.7	ohms
Encoder Resolution	4,000	Counts/Rev
Rotor Inertia	0.001	oz-in-sec ²
	0.706	10 ⁻⁶ Kg-m ²
Weight	1.3	lb
	0.59	kg
Shaft Diameter	0.250	in
	6.35	mm
Shaft, Radial Load	7	lb
	3.18	kg
Shaft, Axial Thrust Load	3	lb
	1.36	kg
DeviceNet Available	Yes	
ProfiBus Available	Yes	
CANopen Available	Yes	

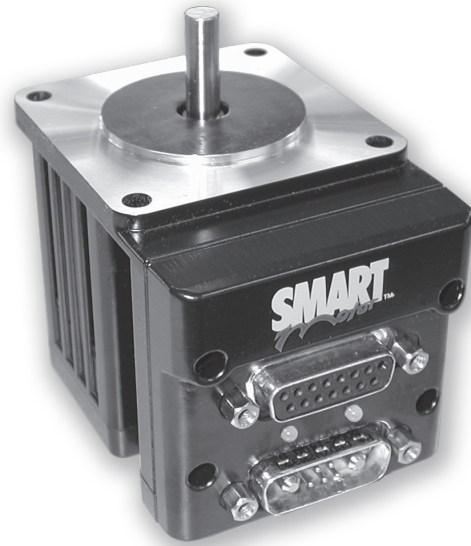

Animatics SmartMotor™ SM23165DT (No Options) CAD Drawing

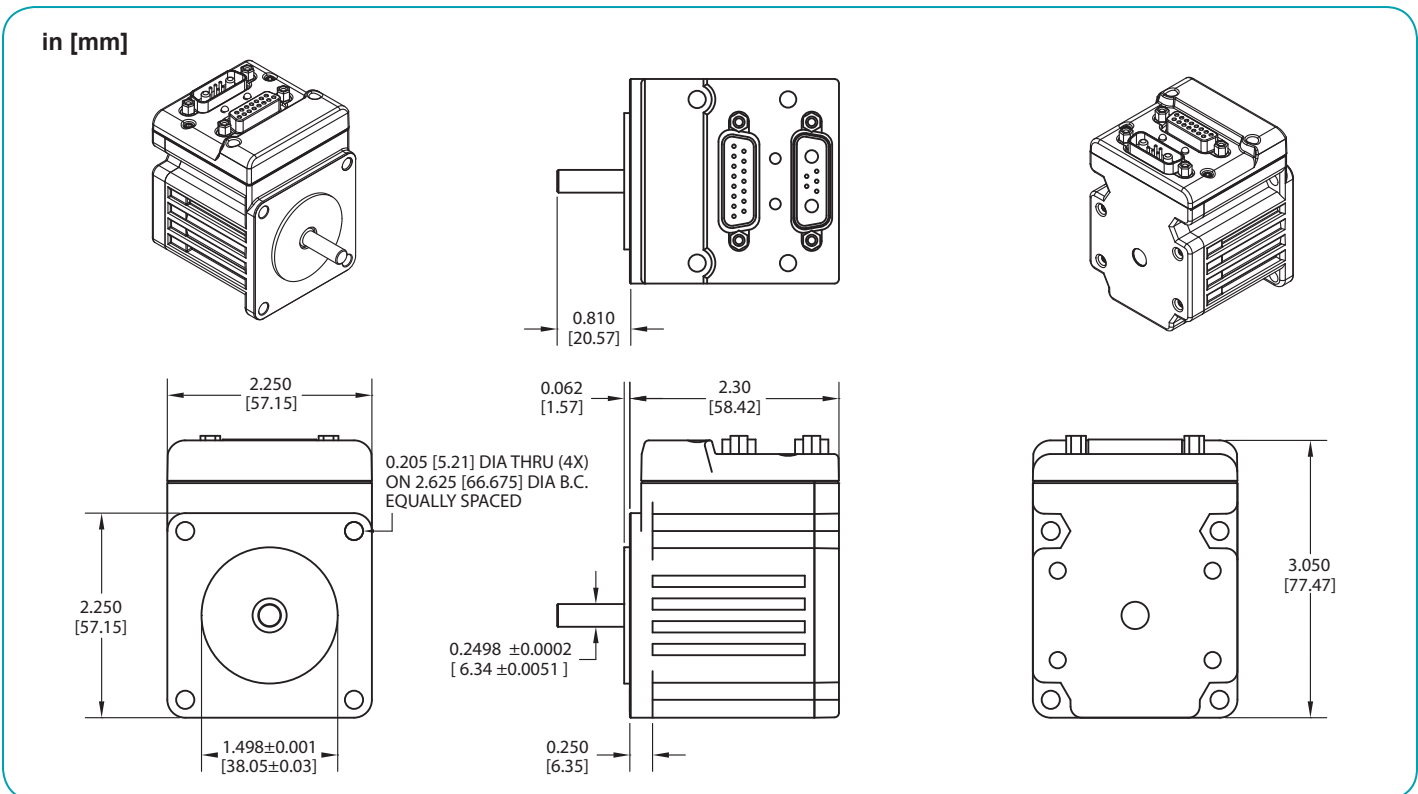

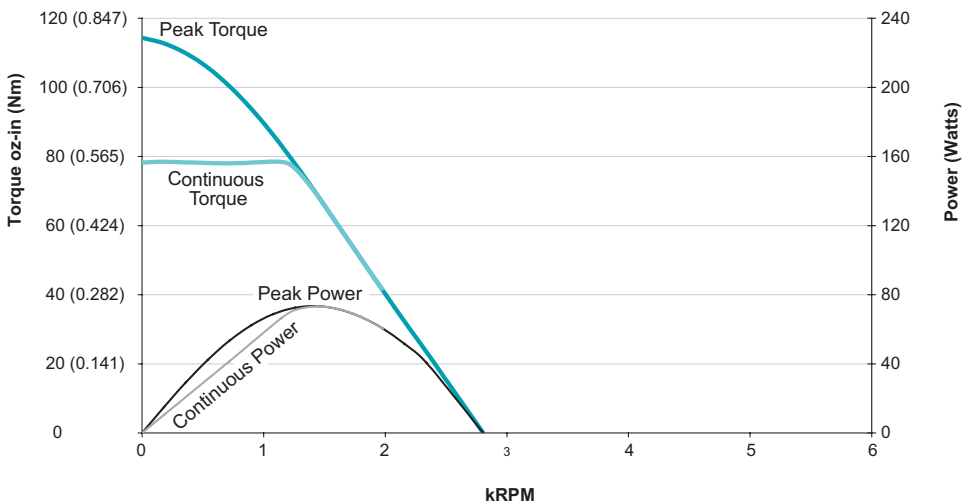
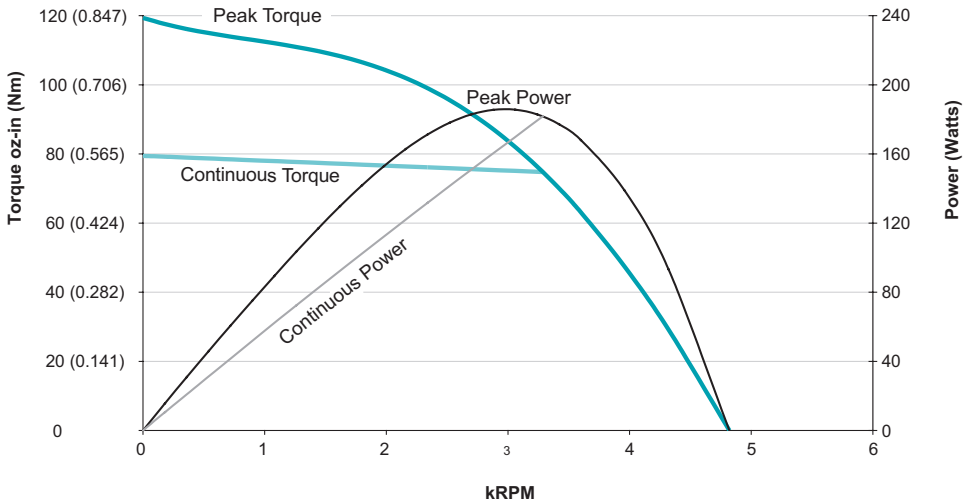
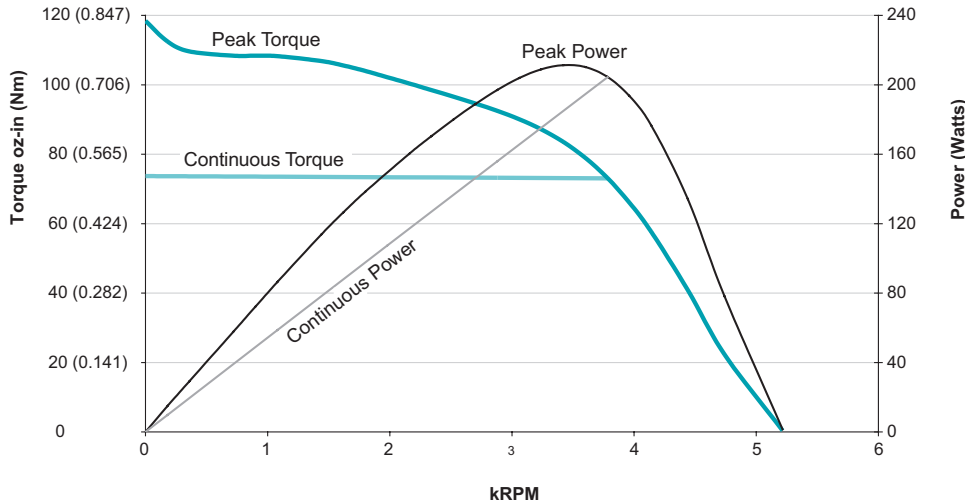

**SM23165DT
at 48 VDC
at rise to 85°C**

**SM23165DT
at 42 VDC
at rise to 85°C**

**SM23165DT
at 24 VDC
at rise to 85°C**

All Torque curves based on 25°C ambient.
Motors were operated in Trap-Commutation Mode.
Please consult factory for Sine-Commutation Torque Curves.

OVERVIEW
MOTOR SPECIFICATIONS
LINEAR SYSTEMS
CONNECTIVITY
PERIPHERALS
IP 65 MODELS & CONNECTIVITY
POWER SUPPLIES & SHUNTS
GEAR HEADS
SOFTWARE
APPENDIX

SM23375D		
Continuous Torque	2.86	in-lb
	46	oz-in
	0.32	N-m
Peak Torque	5.00	in-lb
	80	oz-in
	0.57	N-m
Nominal Continuous Power	191	Watt
No Load Speed	8,000	RPM
Continuous Current @ Nominal Power	5.6	Amps
Voltage Constant	5.62	V/kRPM
Winding Resistance	0.6	ohms
Encoder Resolution	4,000	Counts/Rev
Rotor Inertia	0.0019	oz-in-sec ²
	1.342	10 ⁻⁶ Kg-m ²
Weight	2.1	lb
	0.95	kg
Shaft Diameter	0.250	in
	6.35	mm
Shaft, Radial Load	7	lb
	3.18	kg
Shaft, Axial Thrust Load	3	lb
	1.36	kg
DeviceNet Available	Yes	
ProfiBus Available		
CANopen Available	Yes	



Animatics SmartMotor SM23375D (No Options) CAD Drawing

in [mm]

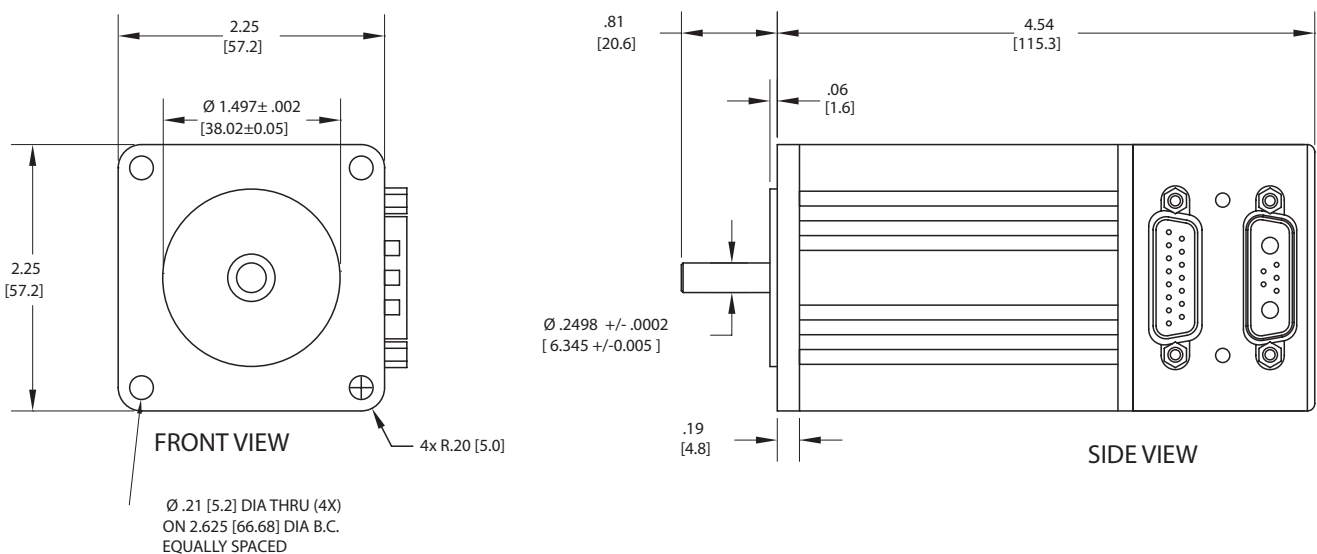

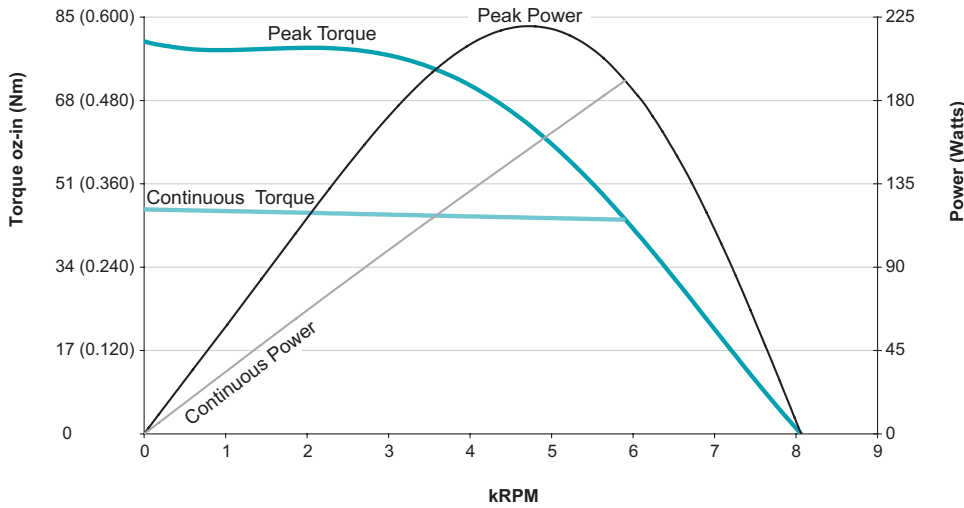

**SM23375D
at 48 VDC
at rise to 85°C**

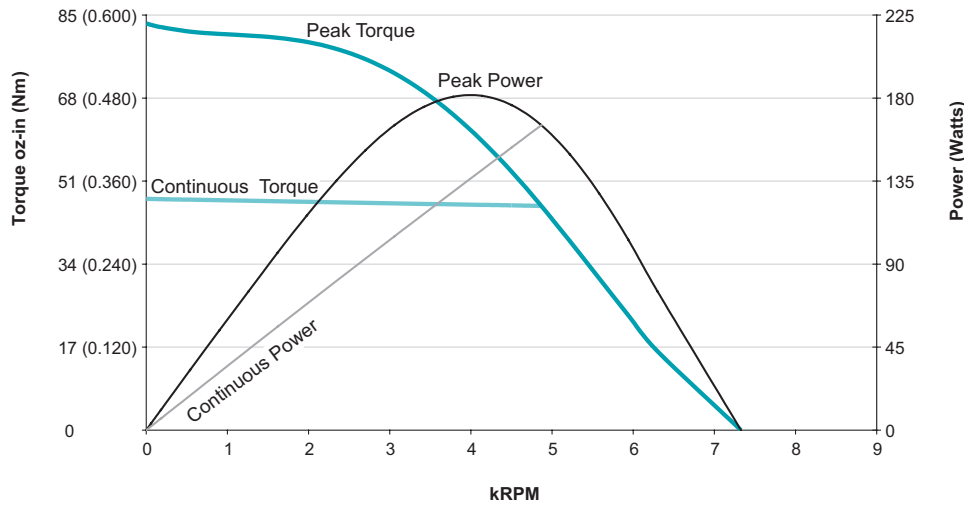

**SM23375D
at 42 VDC
at rise to 85°C**

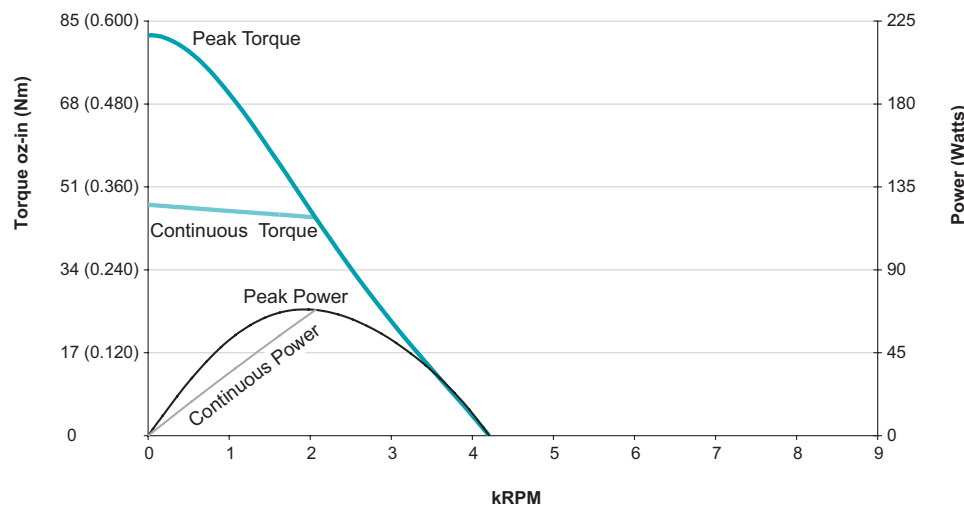

**SM23375D
at 24 VDC
at rise to 85°C**

OVERVIEW
MOTOR SPECIFICATIONS
LINEAR SYSTEMS
CONNECTIVITY
PERIPHERALS
IP 65 MODELS & CONNECTIVITY
POWER SUPPLIES & SHUNTS
GEAR HEADS
SOFTWARE
APPENDIX

SM23375DT		
Continuous Torque	5.18	in-lb
	83	oz-in
	0.59	N-m
Peak Torque	9.80	in-lb
	157	oz-in
	1.11	N-m
Nominal Continuous Power	186	Watt
No Load Speed	4,000	RPM
Continuous Current @ Nominal Power	5.9	Amps
Voltage Constant	10.95	V/kRPM
Winding Resistance	0.9	ohms
Encoder Resolution	4,000	Counts/Rev
Rotor Inertia	0.0019	oz-in-sec ²
	1.342	10 ⁻⁶ Kg-m ²
Weight	2.2	lb
	0.98	kg
Shaft Diameter	0.250	in
	6.35	mm
Shaft, Radial Load	7	lb
	3.18	kg
Shaft, Axial Thrust Load	3	lb
	1.36	kg
DeviceNet Available	Yes	
ProfiBus Available		
CANopen Available	Yes	



Animatics SmartMotor SM23375DT (No Options) CAD Drawing

in [mm]

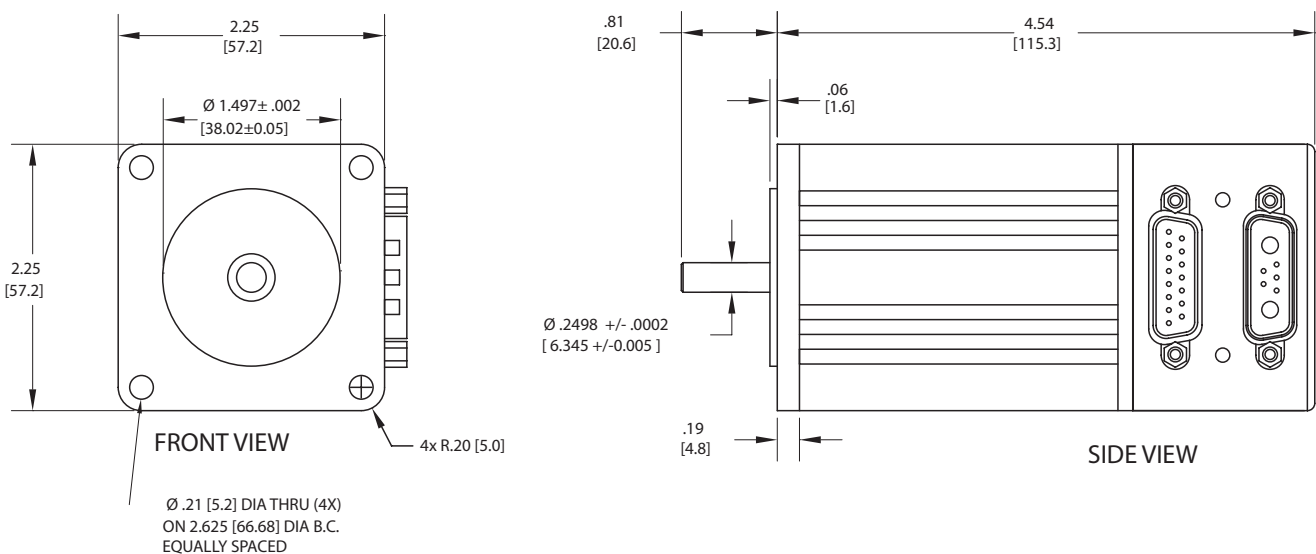

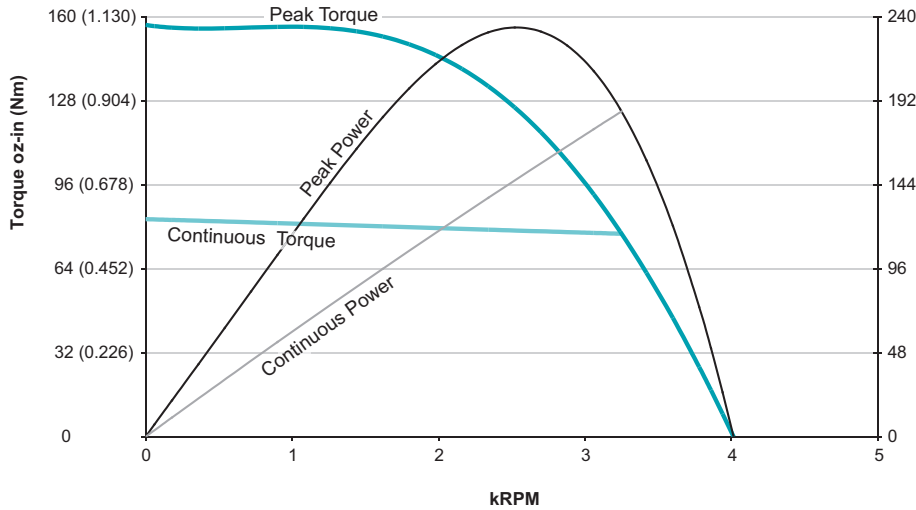

SM23375DT
at 48 VDC
at rise to 85°C

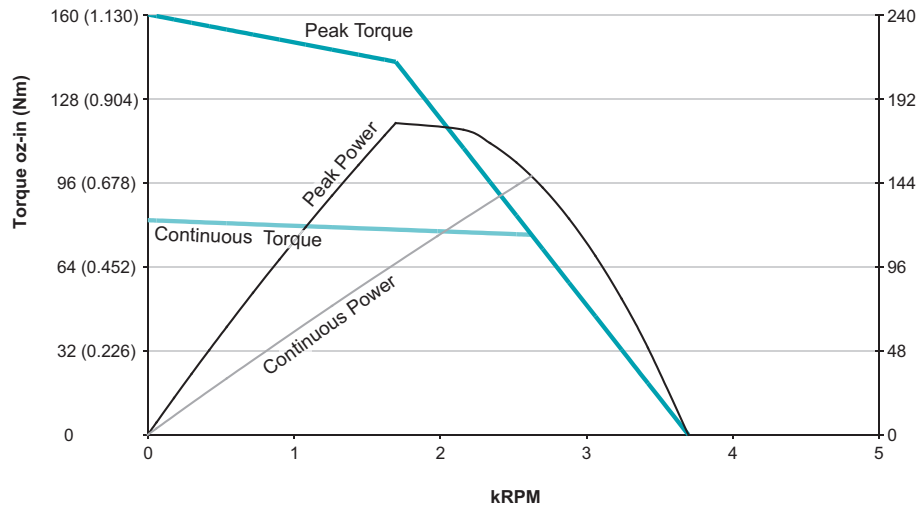

SM23375DT
at 42 VDC
at rise to 85°C

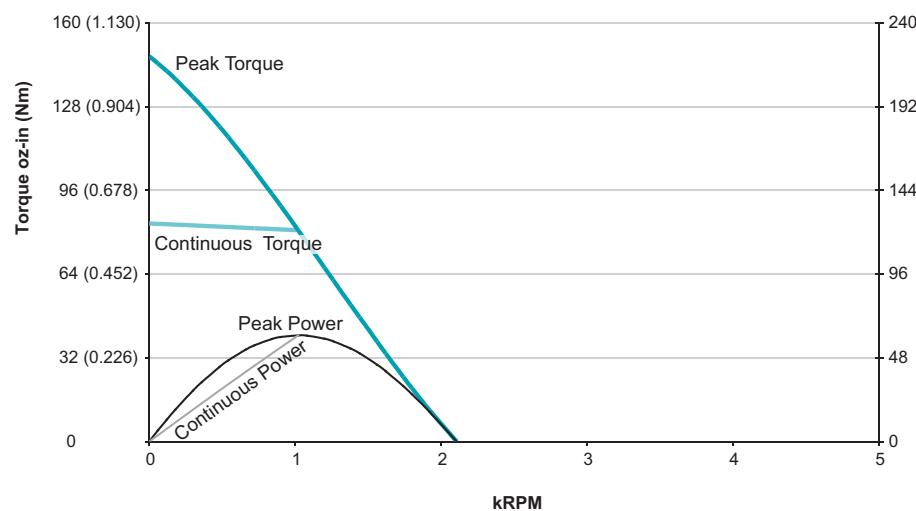

SM23375DT
at 24 VDC
at rise to 85°C

OVERVIEW
MOTOR SPECIFICATIONS
LINEAR SYSTEMS
CONNECTIVITY
PERIPHERALS
IP 65 MODELS & CONNECTIVITY
POWER SUPPLIES & SHUNTS
GEAR HEADS
SOFTWARE
APPENDIX

SM23205D		
Continuous Torque	2.96	in-lb
	47	oz-in
	0.33	N-m
Peak Torque	5.03	in-lb
	80	oz-in
	0.57	N-m
Nominal Continuous Power	226	Watt
No Load Speed	8,100	RPM
Continuous Current @ Nominal Power	6.6	Amps
Voltage Constant	6.6	V/kRPM
Winding Resistance	1.1	ohms
Encoder Resolution	4,000	Counts/Rev
Rotor Inertia	0.00184	oz-in-sec ²
	1.300	10 ⁻⁶ Kg-m ²
Weight	1.7	lb
	0.79	kg
Shaft Diameter	0.250	in
	6.35	mm
Shaft, Radial Load	7	lb
	3.18	kg
Shaft, Axial Thrust Load	3	lb
	1.36	kg
DeviceNet Available	Yes	
Profibus Available		
CANopen Available	Yes	

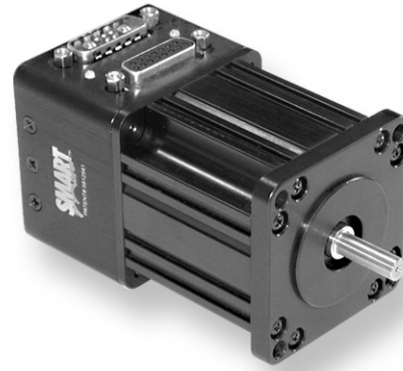

Animatics SmartMotor SM23205D (No Options) CAD Drawing

in [mm]

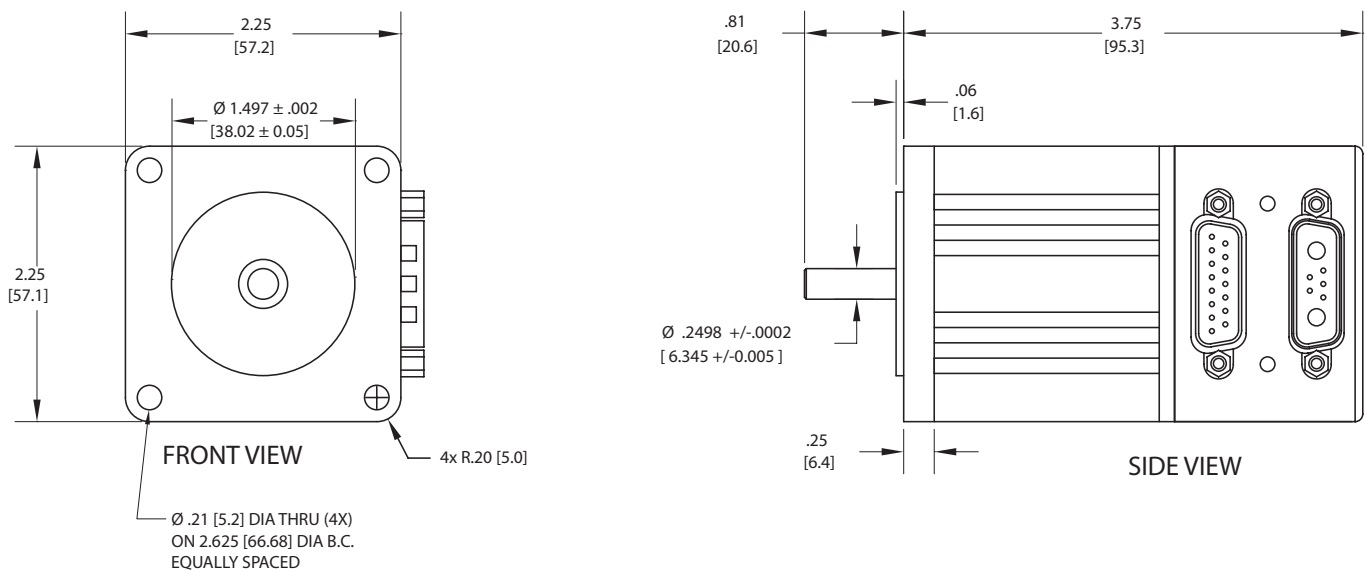

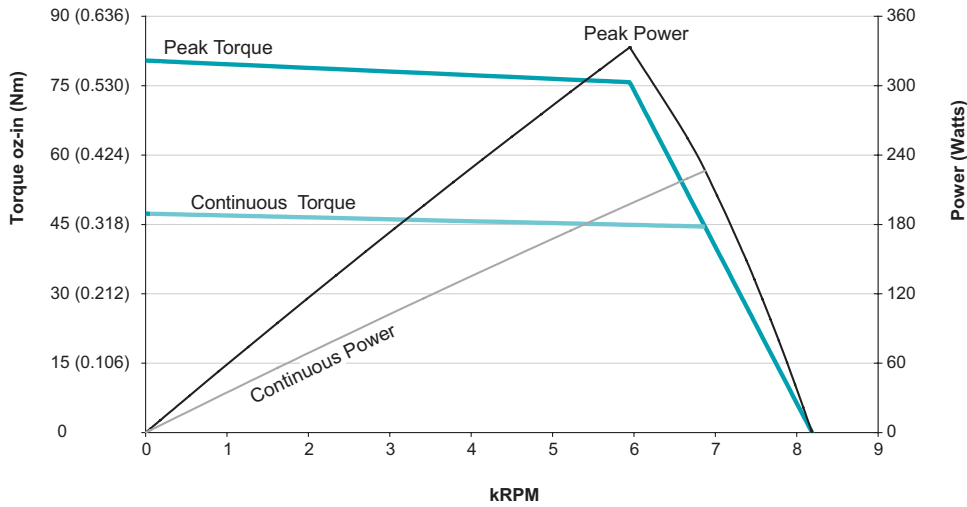

SM23205D
at 48 VDC
at rise to 85°C

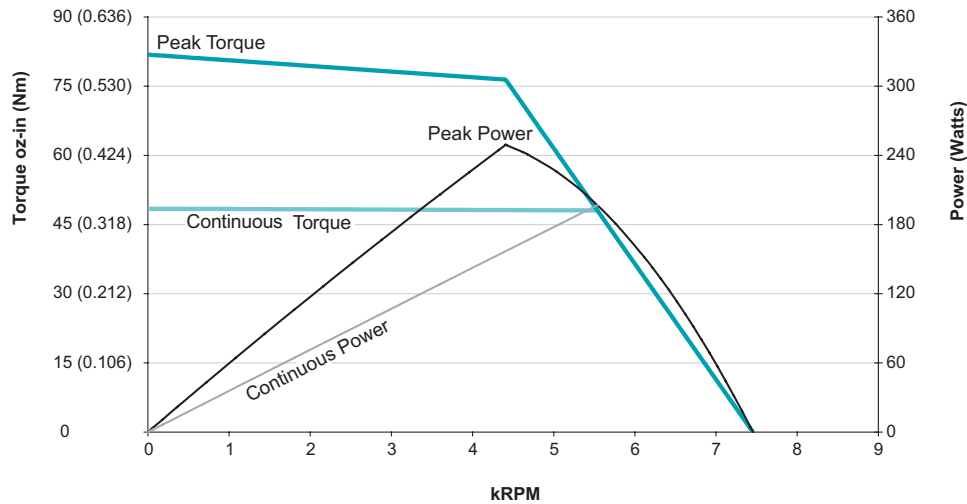

SM23205D
at 42 VDC
at rise to 85°C

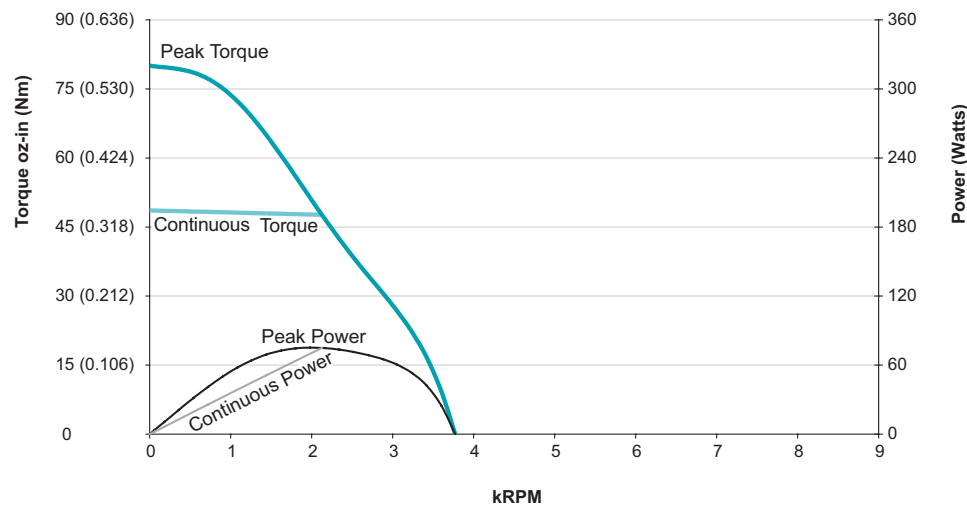

SM23205D
at 24 VDC
at rise to 85°C

OVERVIEW
MOTOR SPECIFICATIONS
LINEAR SYSTEMS
CONNECTIVITY
PERIPHERALS
IP 65 MODELS & CONNECTIVITY
POWER SUPPLIES & SHUNTS
GEAR HEADS
SOFTWARE
APPENDIX

SM23305D		
Continuous Torque	3.98	in-lb
	64	oz-in
	0.45	N-m
Peak Torque	6.86	in-lb
	110	oz-in
	0.77	N-m
Nominal Continuous Power	220	Watt
No Load Speed	5,600	RPM
Continuous Current @ Nominal Power	6.8	Amps
Voltage Constant	9.32	V/kRPM
Winding Resistance	1.2	ohms
Encoder Resolution	4,000	Counts/Rev
Rotor Inertia	0.00273	oz-in-sec ²
	1.928	10 ⁻⁵ Kg-m ²
Weight	2.3	lb
	1.03	kg
Shaft Diameter	0.250	in
	6.35	mm
Shaft, Radial Load	7	lb
	3.18	kg
Shaft, Axial Thrust Load	3	lb
	1.36	kg
DeviceNet Available	Yes	
ProfiBus Available		
CANopen Available	Yes	



Animatics SmartMotor SM23305D (No Options) CAD Drawing

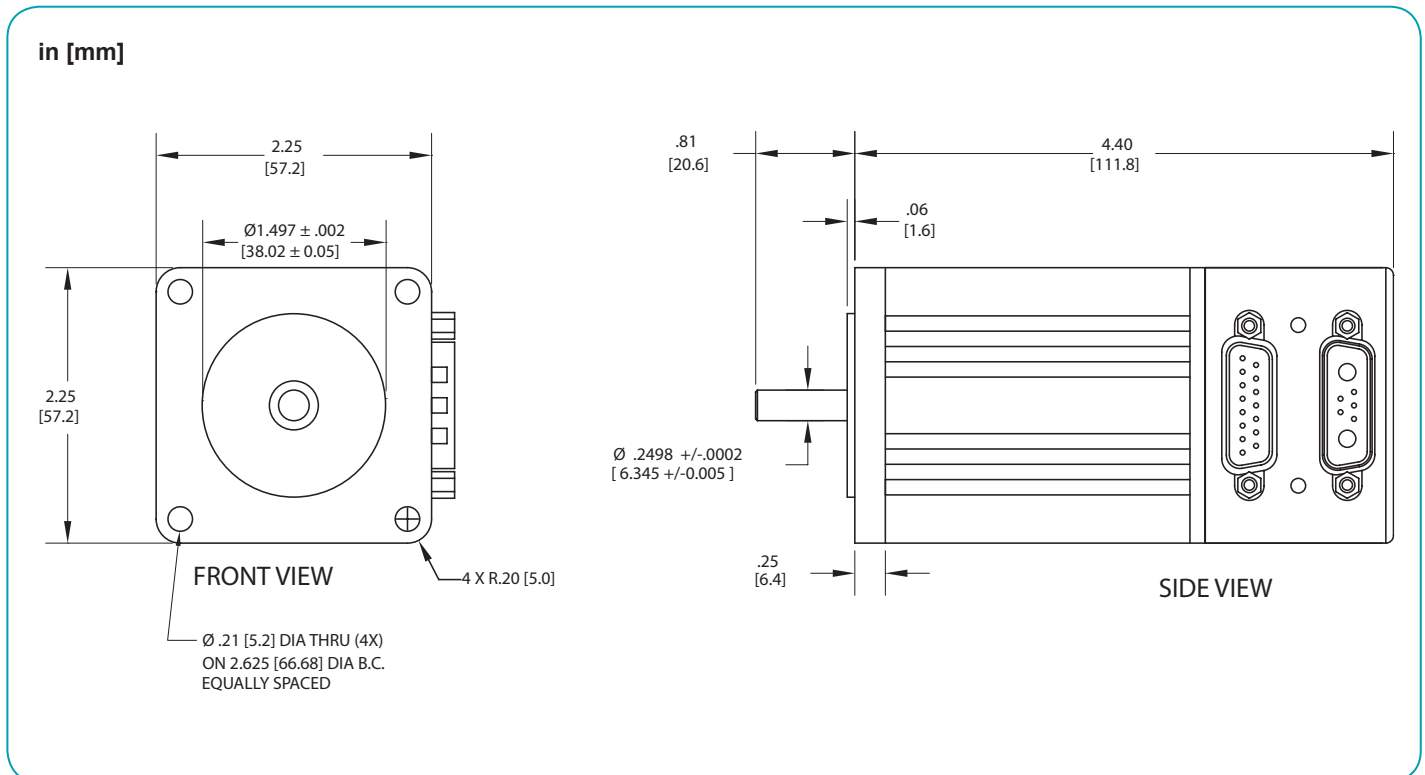

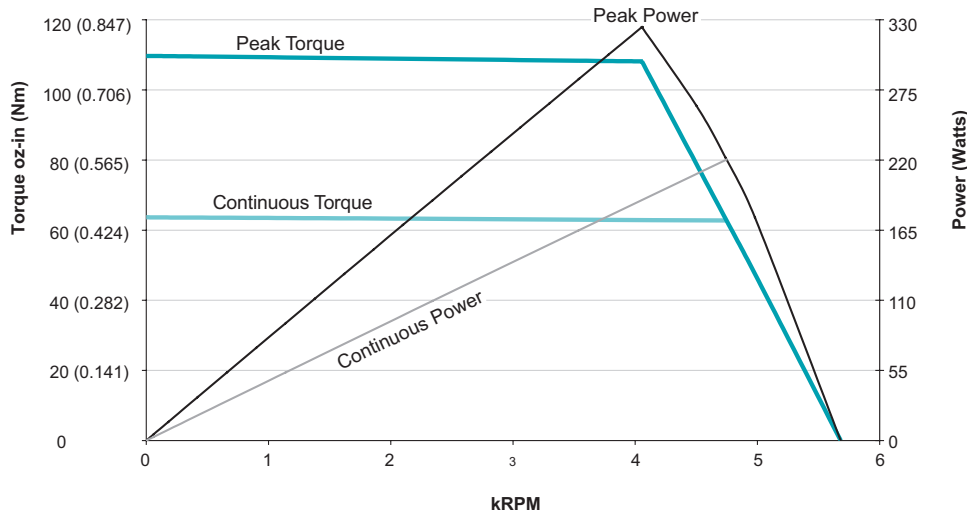

SM23305D
at 48 VDC
at rise to 85°C

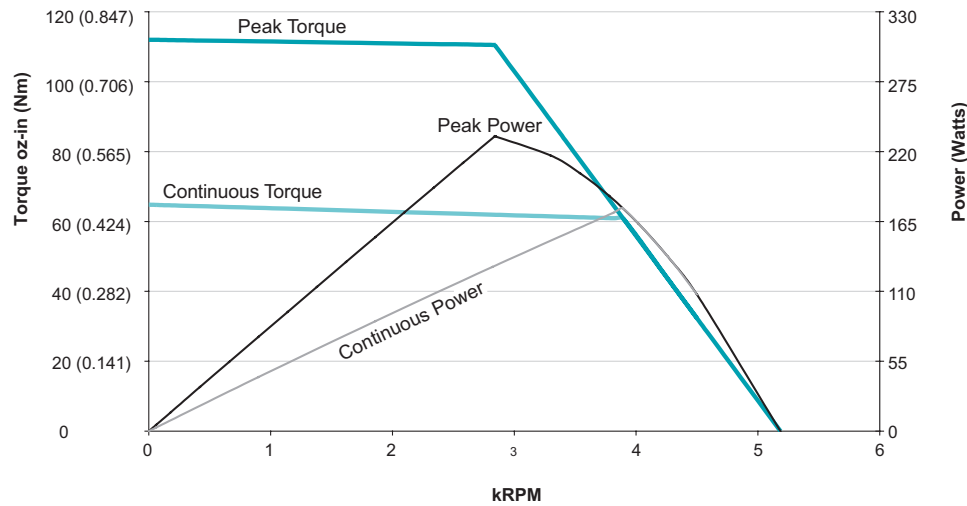

SM23305D
at 42 VDC
at rise to 85°C

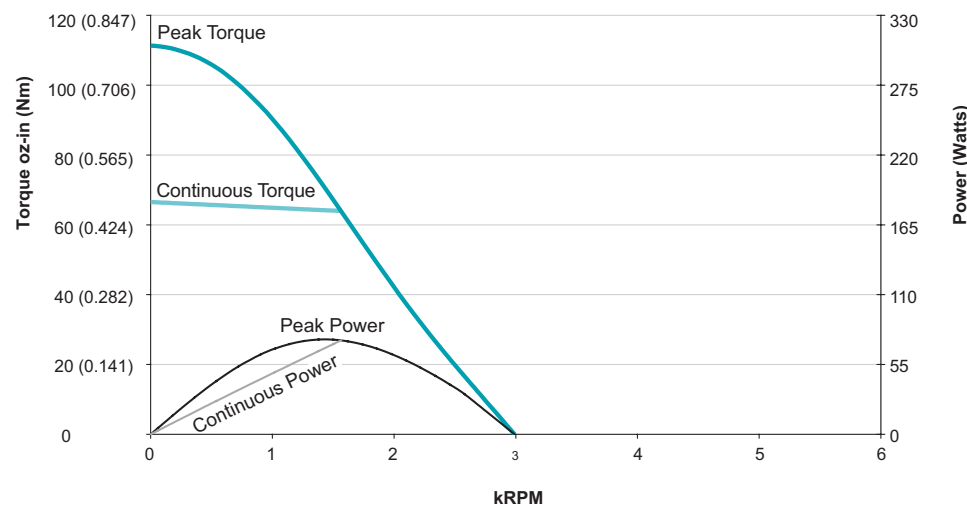

SM23305D
at 24 VDC
at rise to 85°C

OVERVIEW
MOTOR SPECIFICATIONS
LINEAR SYSTEMS
CONNECTIVITY
PERIPHERALS
IP 65 MODELS & CONNECTIVITY
POWER SUPPLIES & SHUNTS
GEAR HEADS
SOFTWARE
APPENDIX

SM23405D		
Continuous Torque	4.88	in-lb
	78	oz-in
	0.55	N-m
Peak Torque	8.04	in-lb
	129	oz-in
	0.91	N-m
Nominal Continuous Power	253	Watt
No Load Speed	5,300	RPM
Continuous Current @ Nominal Power	7.5	Amps
Voltage Constant	10.26	V/kRPM
Winding Resistance	1.0	ohms
Encoder Resolution	4,000	Counts/Rev
Rotor Inertia	0.00362	oz-in-sec ²
	2.557	10 ⁻⁶ Kg-m ²
Weight	2.8	lb
	1.27	kg
Shaft Diameter	0.250	in
	6.35	mm
Shaft, Radial Load	7	lb
	3.18	kg
Shaft, Axial Thrust Load	3	lb
	1.36	kg
DeviceNet Available	Yes	
ProfiBus Available		
CANopen Available	Yes	



Animatics SmartMotor SM23405D (No Options) CAD Drawing

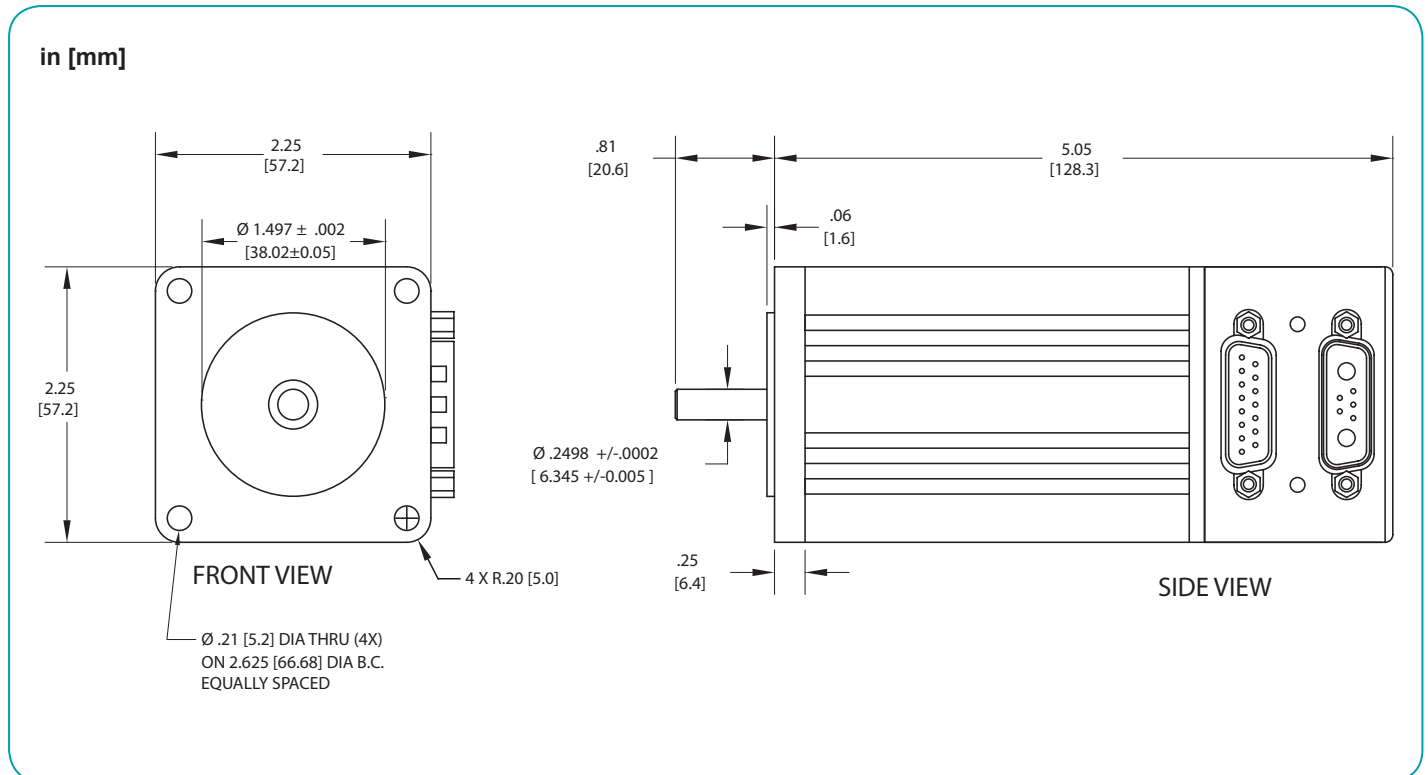

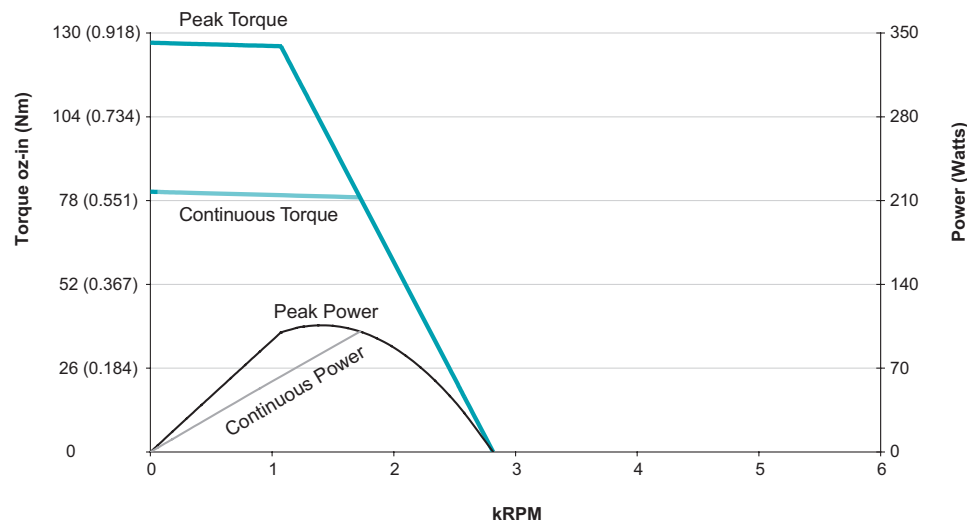
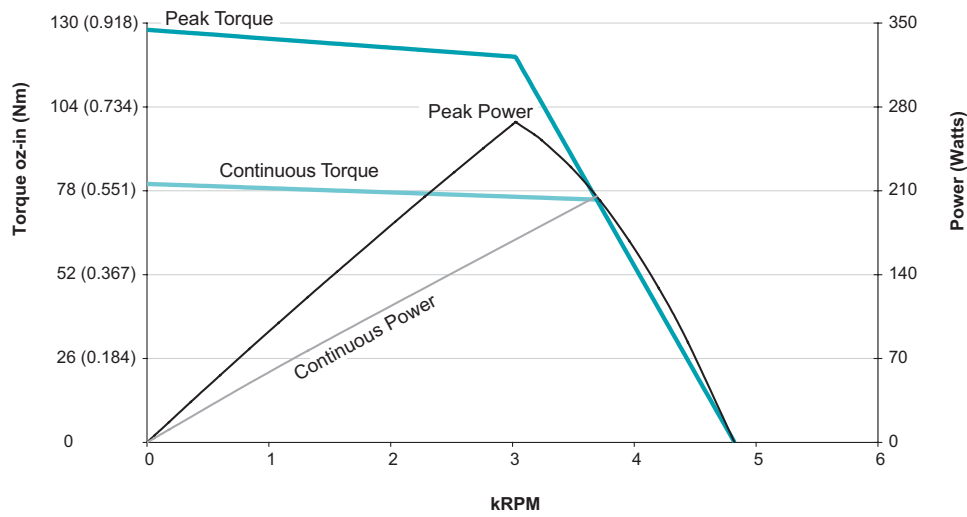
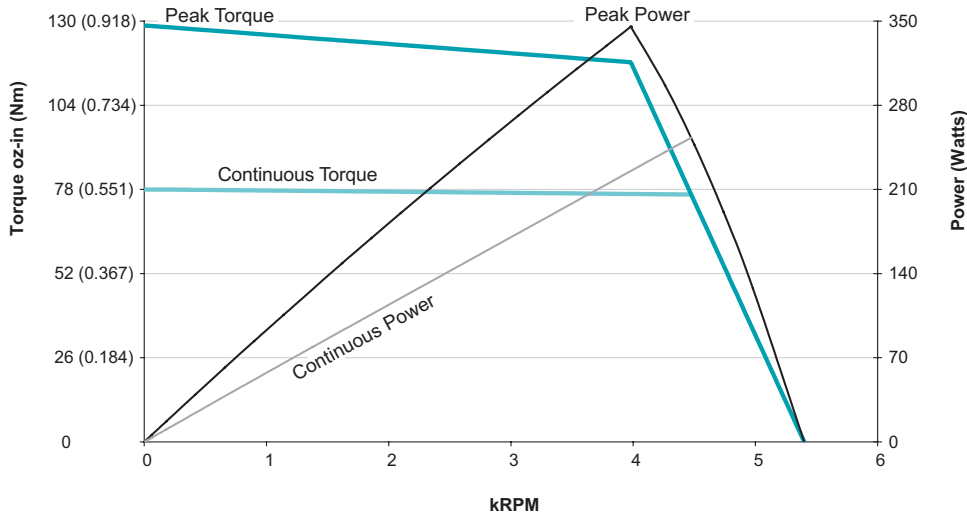

OVERVIEW
MOTOR SPECIFICATIONS
LINEAR SYSTEMS
CONNECTIVITY
PERIPHERALS
IP 65 MODELS & CONNECTIVITY
POWER SUPPLIES & SHUNTS
GEAR HEADS
SOFTWARE
APPENDIX

SM34165D		
Continuous Torque	9.67	in-lb
	155	oz-in
	1.09	N-m
Peak Torque	14.12	in-lb
	226	oz-in
	1.60	N-m
Nominal Continuous Power	235	Watt
No Load Speed	3,100	RPM
Continuous Current @ Nominal Power	7.4	Amps
Voltage Constant	15.5	V/kRPM
Winding Resistance	0.6	ohms
Encoder Resolution	8,000	Counts/Rev
Rotor Inertia	0.014	oz-in-sec ²
	9.890	10 ⁻⁶ Kg-m ²
Weight	5.0	lb
	2.27	kg
Shaft Diameter	0.375	in
	9.53	mm
Shaft, Radial Load	15	lb
	6.80	kg
Shaft, Axial Thrust Load	3	lb
	1.36	kg
DeviceNet Available	Yes	
ProfiBus Available	Yes	
CANopen Available	Yes	



Animatics SmartMotor™ SM34165D (No Options) CAD Drawing

in [mm]

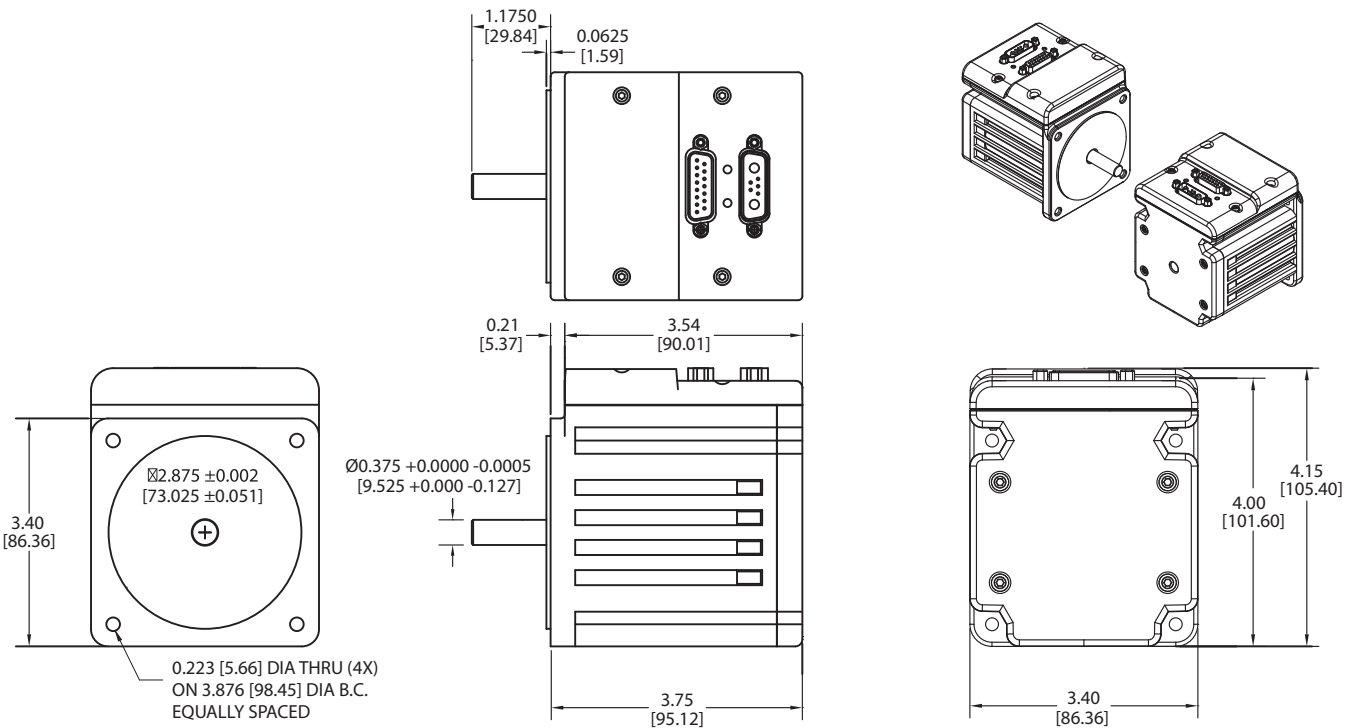

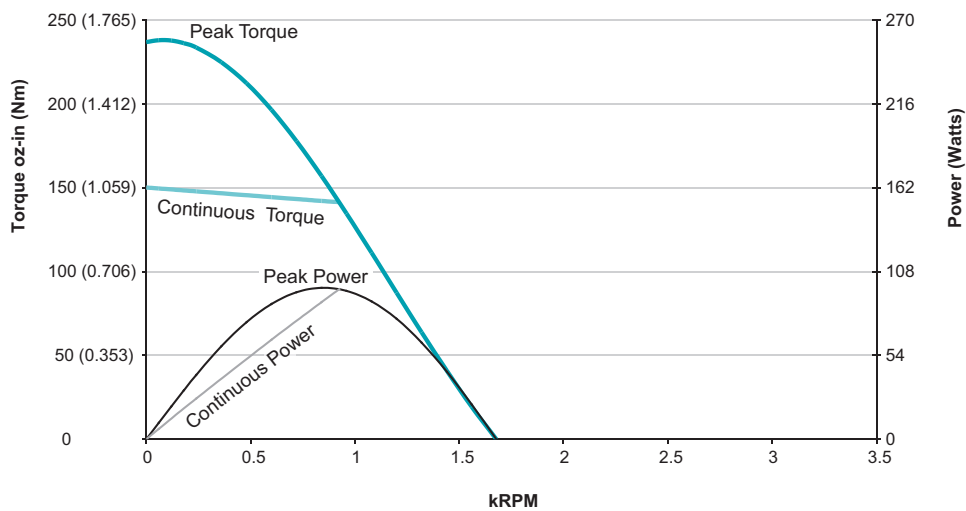
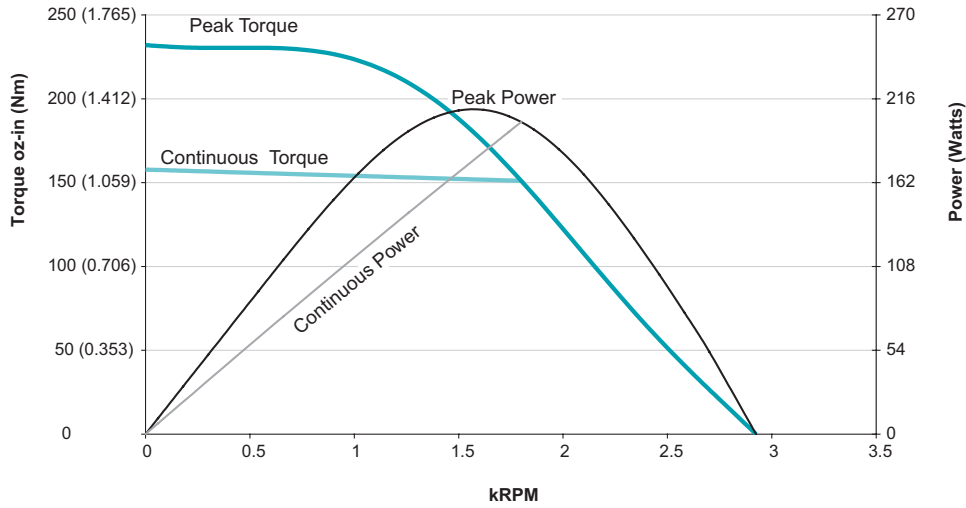
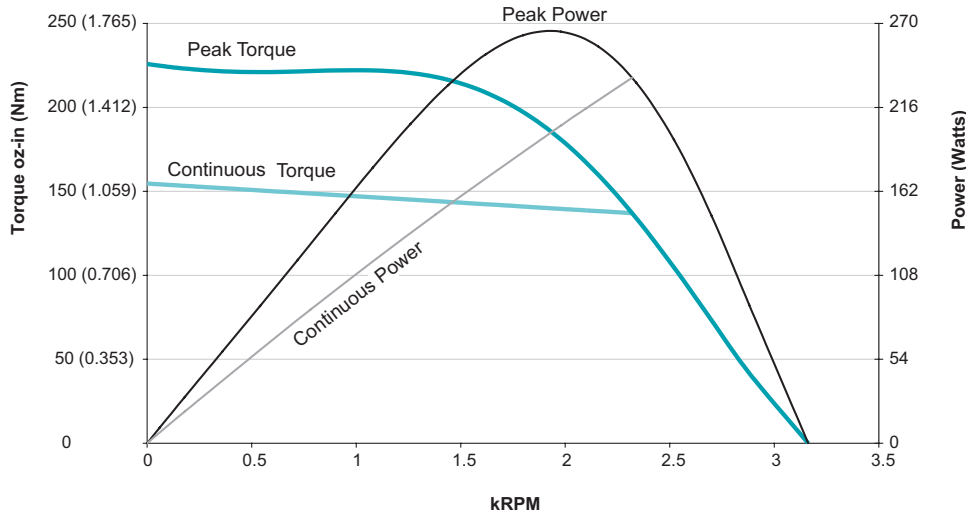

**SM34165D
at 48 VDC
at rise to 85°C**

**SM34165D
at 42 VDC
at rise to 85°C**

**SM34165D
at 24 VDC
at rise to 85°C**

All Torque curves based on 25°C ambient.
Motors were operated in Trap-Commutation Mode.
Please consult factory for Sine-Commutation Torque Curves.

OVERVIEW
MOTOR SPECIFICATIONS
LINEAR SYSTEMS
CONNECTIVITY
PERIPHERALS
IP 65 MODELS & CONNECTIVITY
POWER SUPPLIES & SHUNTS
GEAR HEADS
SOFTWARE
APPENDIX

SM34165DT		
Continuous Torque	12.83	in-lb
	205	oz-in
	1.45	N-m
Peak Torque	30.00	in-lb
	480	oz-in
	3.39	N-m
Nominal Continuous Power	615	Watt
No Load Speed	5,100	RPM
Continuous Current @ Nominal Power	15.5	Amps
Voltage Constant	8.9	V/kRPM
Winding Resistance	0.06	ohms
Encoder Resolution	8,000	Counts/Rev
Rotor Inertia	0.0142	oz-in-sec ²
	10.031	10 ⁻⁶ Kg-m ²
Weight	5.5	lb
	2.49	kg
Shaft Diameter	0.500	in
	12.70	mm
Shaft, Radial Load	30	lb
	13.61	kg
Shaft, Axial Thrust Load	3	lb
	1.36	kg
DeviceNet Available	Yes	
ProfiBus Available	Yes	
CANopen Available	Yes	



Animatics SmartMotor™ SM34165DT (No Options) CAD Drawing

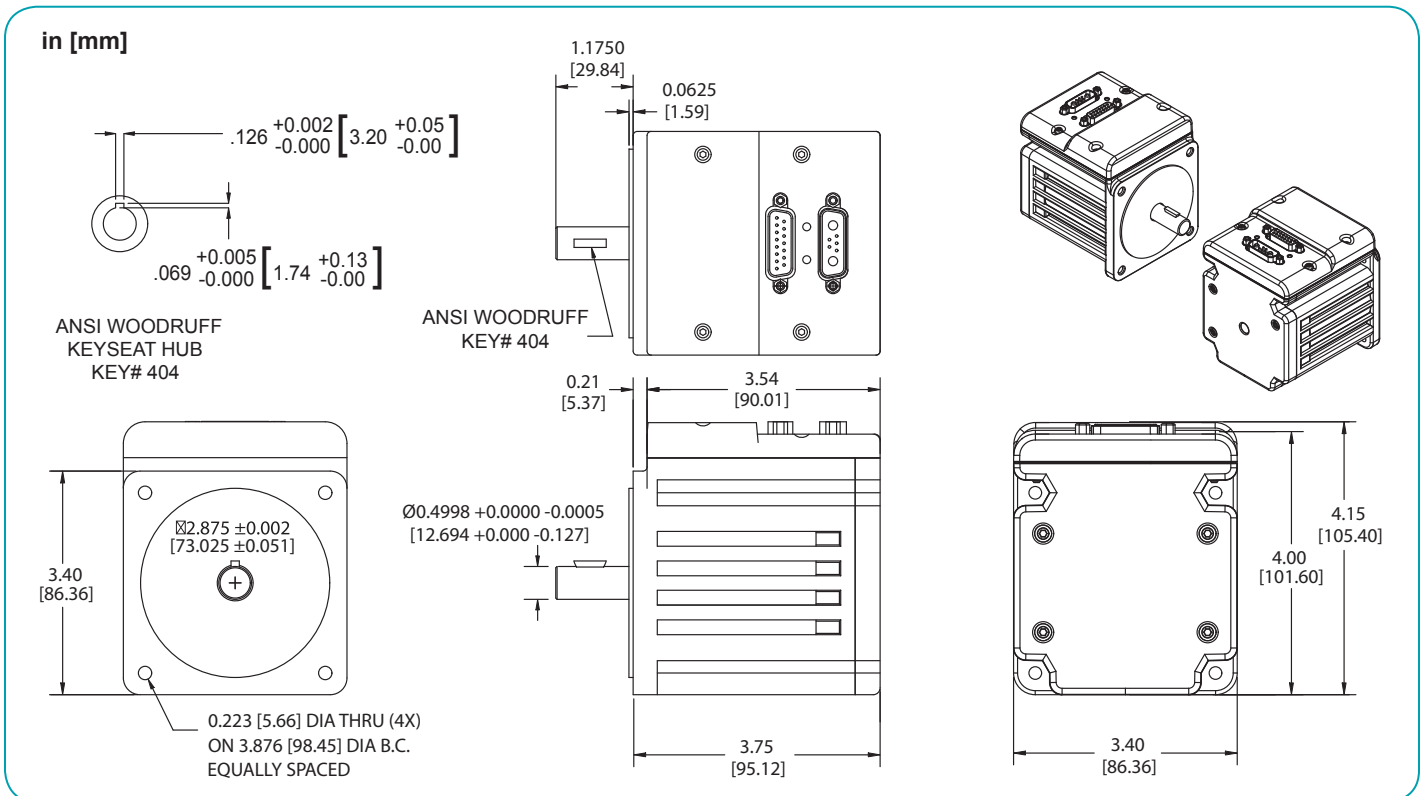

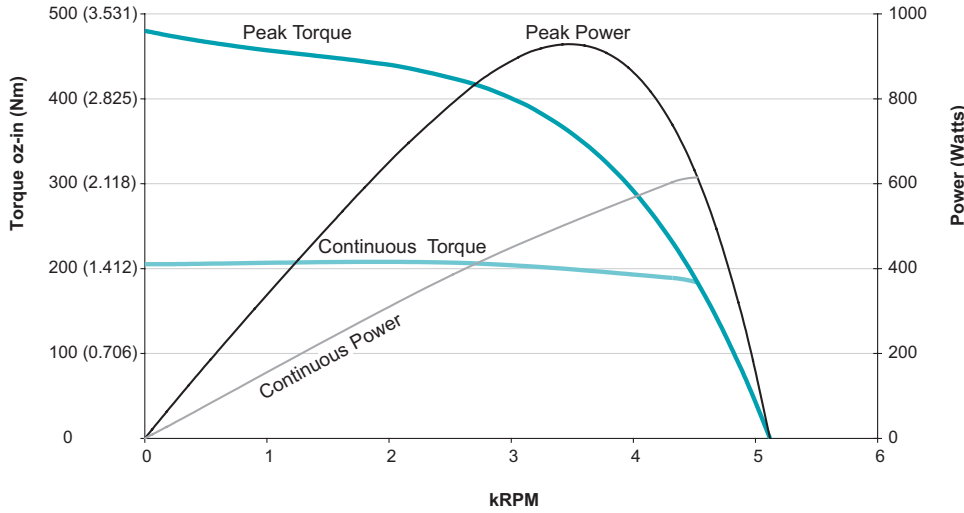

**SM34165DT
at 48 VDC
at rise to 85°C**

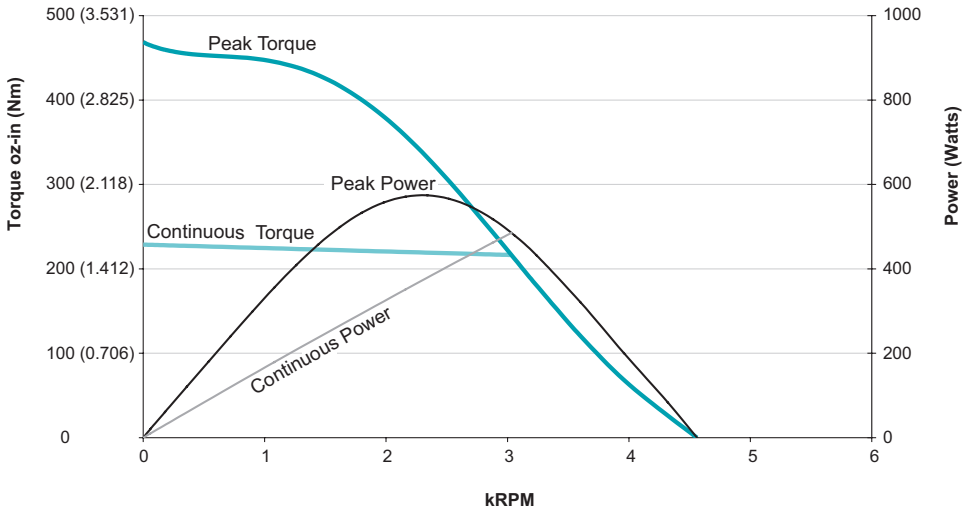

**SM34165DT
at 42 VDC
at rise to 85°C**

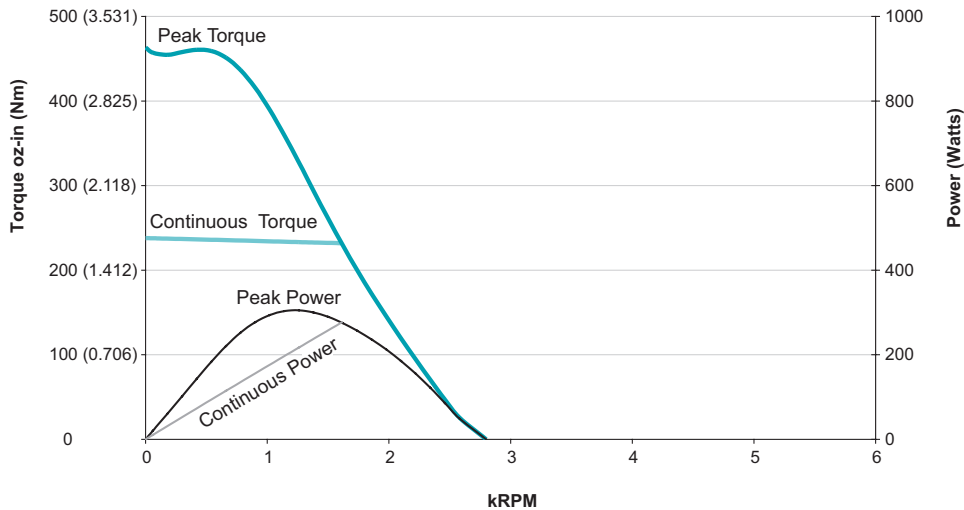

**SM34165DT
at 24 VDC
at rise to 85°C**

All Torque curves based on 25°C ambient.
Motors were operated in Trap-Commutation Mode.
Please consult factory for Sine-Commutation Torque Curves.

OVERVIEW
MOTOR SPECIFICATIONS
LINEAR SYSTEMS
CONNECTIVITY
PERIPHERALS
CONNECTIVITY
IP 65 MODELS & CONNECTIVITY
POWER SUPPLIES & SHUNTS
GEAR HEADS
SOFTWARE
APPENDIX

SM34205D		
Continuous Torque	7.91	in-lb
	126	oz-in
	0.89	N-m
Peak Torque	24.91	in-lb
	399	oz-in
	2.81	N-m
Nominal Continuous Power	324	Watt
No Load Speed	4,500	RPM
Continuous Current @ Nominal Power	9.4	Amps
Voltage Constant	10.8	V/kRPM
Winding Resistance	1.2	ohms
Encoder Resolution	8,000	Counts/Rev
Rotor Inertia	0.013	oz-in-sec ²
	9.183	10 ⁻⁶ Kg-m ²
Weight	3.5	lb
	1.59	kg
Shaft Diameter	0.375	in
	9.53	mm
Shaft, Radial Load	15	lb
	6.80	kg
Shaft, Axial Thrust Load	3	lb
	1.36	kg
DeviceNet Available	Yes	
ProfiBus Available		
CANopen Available	Yes	



Animatics SmartMotor SM34205D (No Options) CAD Drawing

in [mm]

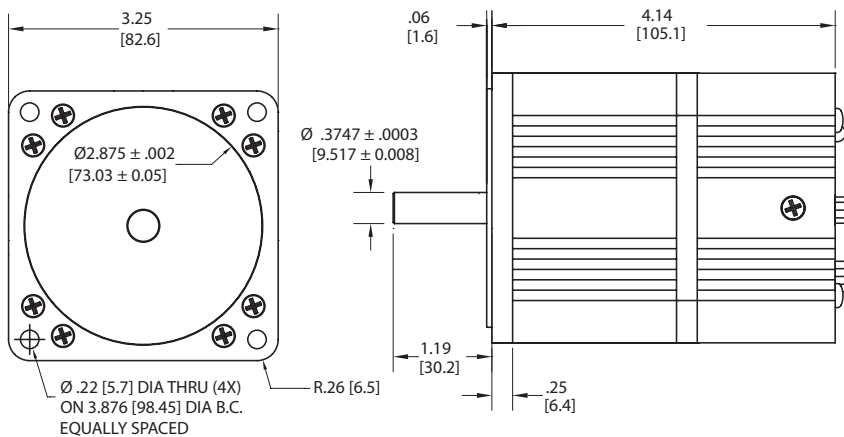

FRONT VIEW

SIDE VIEW

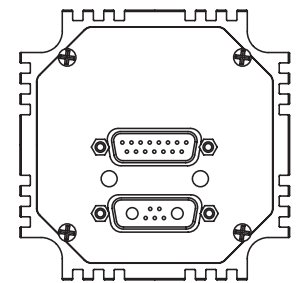

REAR VIEW

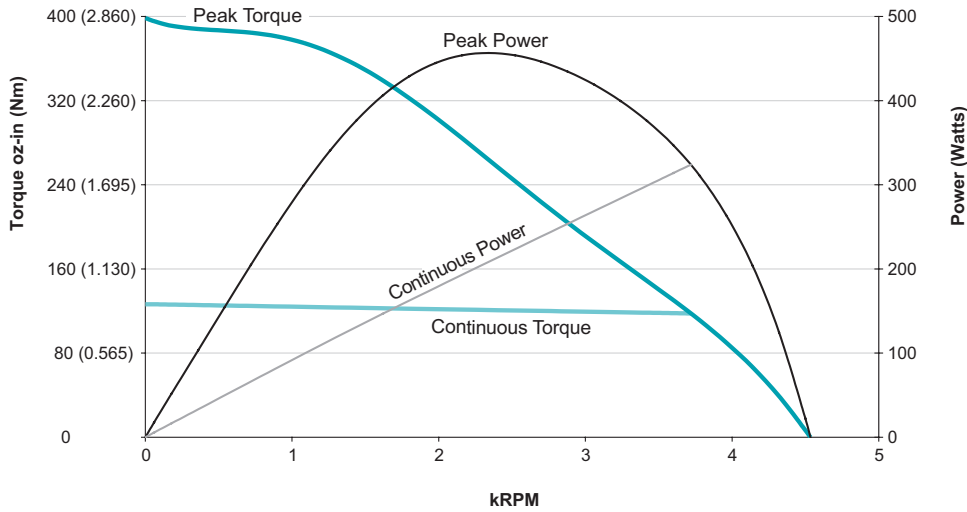

**SM34205D
at 48 VDC
at rise to 85°C**

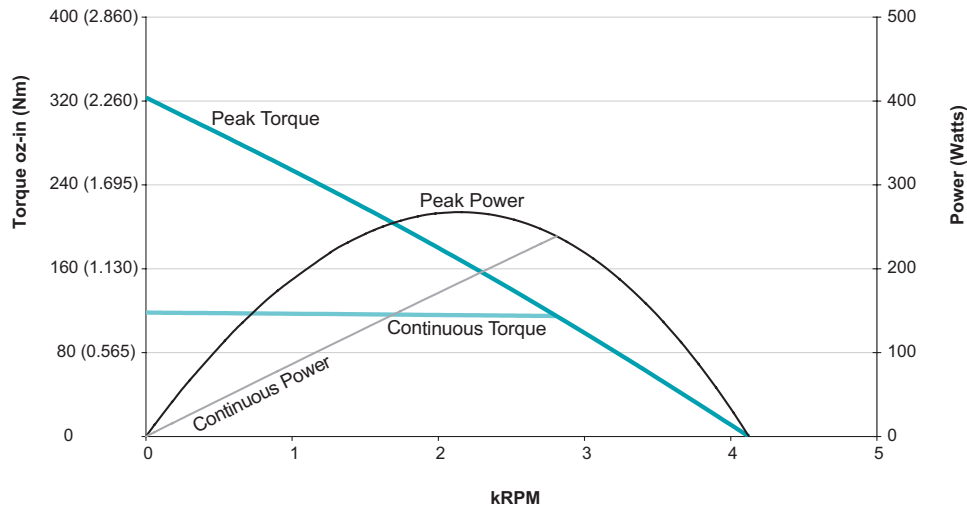

**SM34205D
at 42 VDC
at rise to 85°C**

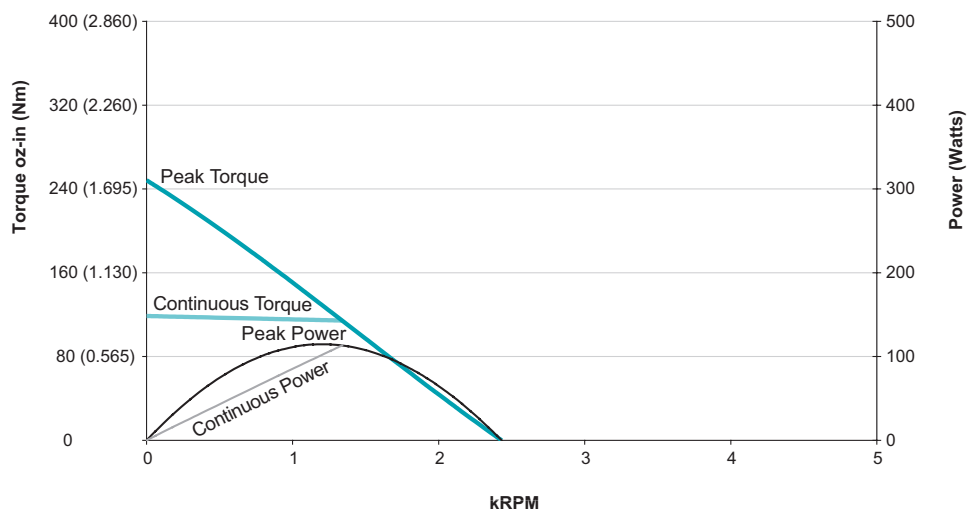

**SM34205D
at 24 VDC
at rise to 85°C**

OVERVIEW
MOTOR SPECIFICATIONS
LINEAR SYSTEMS
CONNECTIVITY
PERIPHERALS
IP 65 MODELS & CONNECTIVITY
POWER SUPPLIES & SHUNTS
GEAR HEADS
SOFTWARE
APPENDIX

SM34305D		
Continuous Torque	10.87	in-lb
	174	oz-in
	1.23	N-m
Peak Torque	34.75	in-lb
	556	oz-in
	3.93	N-m
Nominal Continuous Power	400	Watt
No Load Speed	4,100	RPM
Continuous Current @ Nominal Power	10.9	Amps
Voltage Constant	12.1	V/kRPM
Winding Resistance	0.9	ohms
Encoder Resolution	8,000	Counts/Rev
Rotor Inertia	0.019	oz-in-sec ²
	13.422	10 ⁻⁶ Kg-m ²
Weight	4.5	lb
	2.04	kg
Shaft Diameter	0.375	in
	9.53	mm
Shaft, Radial Load	15	lb
	6.80	kg
Shaft, Axial Thrust Load	3	lb
	1.36	kg
DeviceNet Available	Yes	
ProfiBus Available		
CANopen Available	Yes	



Animatics SmartMotor SM34305D (No Options) CAD Drawing

in [mm]

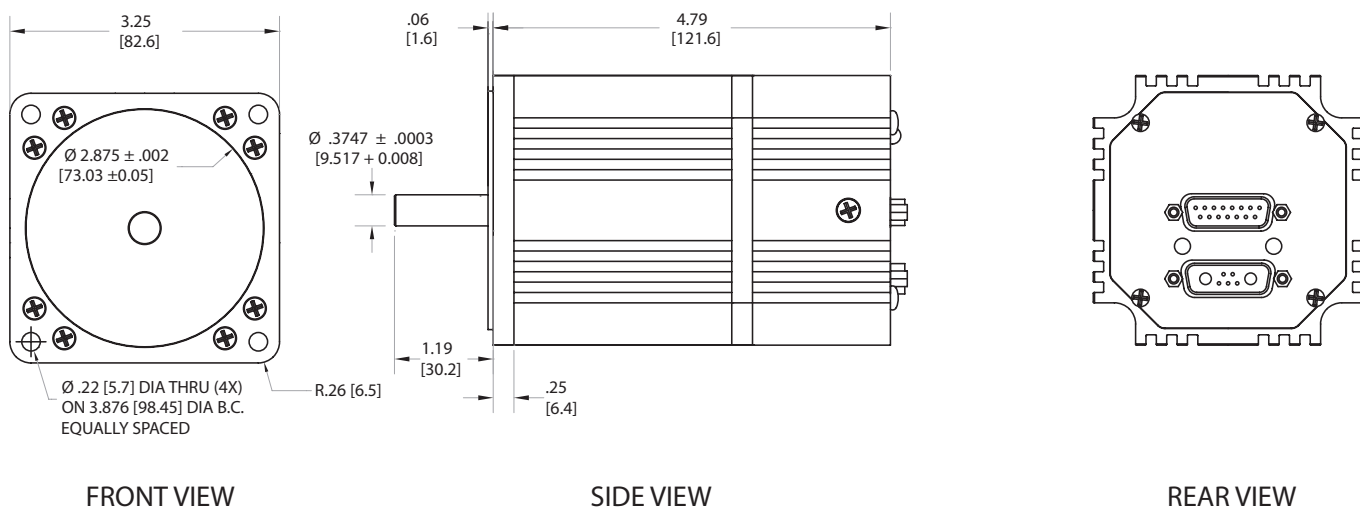

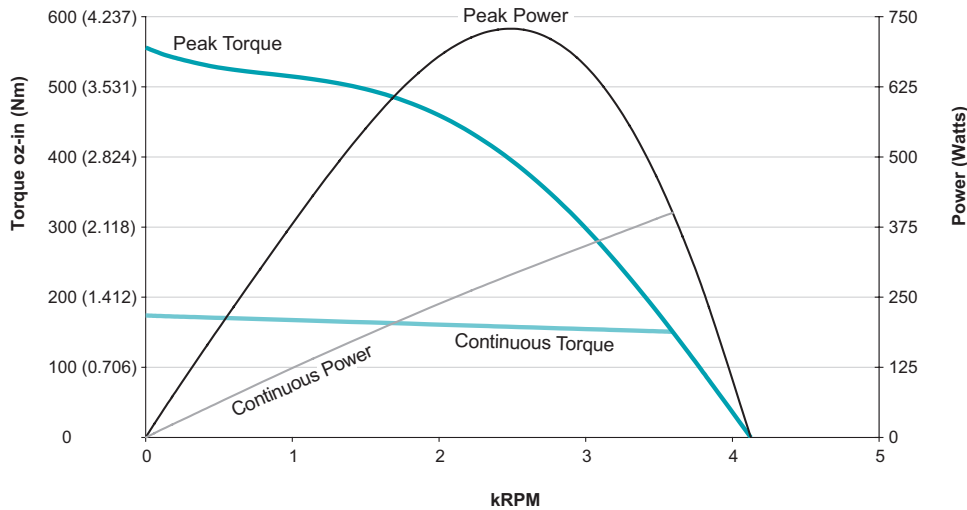

**SM34305D
at 48 VDC
at rise to 85°C**

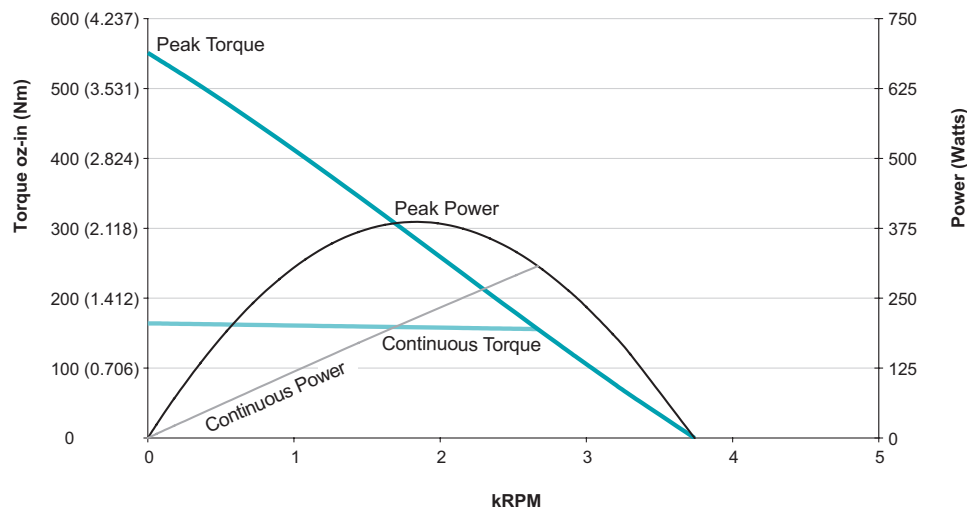

**SM34305D
at 42 VDC
at rise to 85°C**

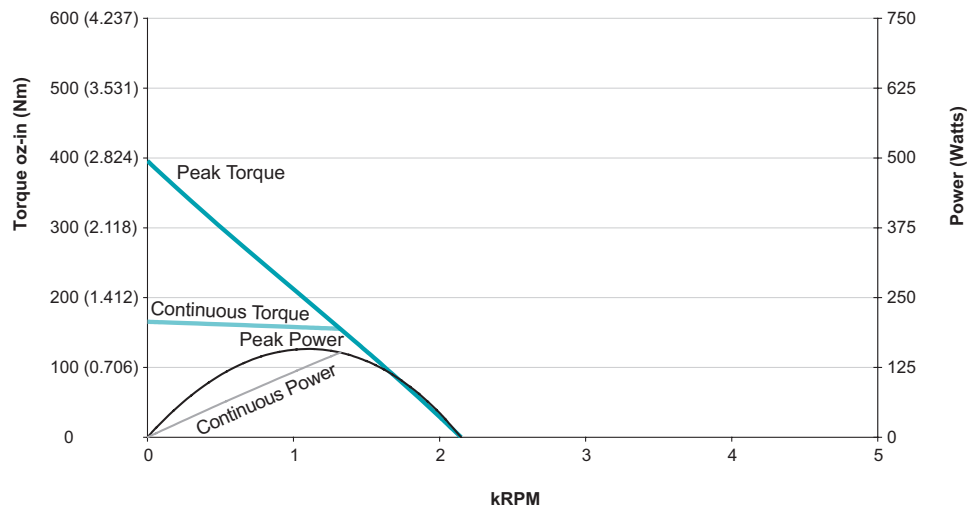

**SM34305D
at 24 VDC
at rise to 85°C**

OVERVIEW
MOTOR SPECIFICATIONS
LINEAR SYSTEMS
CONNECTIVITY
PERIPHERALS
IP 65 MODELS & CONNECTIVITY
POWER SUPPLIES & SHUNTS
GEAR HEADS
SOFTWARE
APPENDIX

SM34405D		
Continuous Torque	12.94	in-lb
	207	oz-in
	1.46	N-m
Peak Torque	40.38	in-lb
	646	oz-in
	4.56	N-m
Nominal Continuous Power	438	Watt
No Load Speed	3,800	RPM
Continuous Current @ Nominal Power	11.6	Amps
Voltage Constant	12.9	V/kRPM
Winding Resistance	0.6	ohms
Encoder Resolution	8,000	Counts/Rev
Rotor Inertia	0.025	oz-in-sec ²
	17.660	10 ⁻⁵ Kg-m ²
Weight	5.5	lb
	2.49	kg
Shaft Diameter	0.375	in
	9.53	mm
Shaft, Radial Load	15	lb
	6.80	kg
Shaft, Axial Thrust Load	3	lb
	1.36	kg
DeviceNet Available	Yes	
ProfiBus Available		
CANopen Available	Yes	



Animatics SmartMotor SM34405D (No Options) CAD Drawing

in [mm]

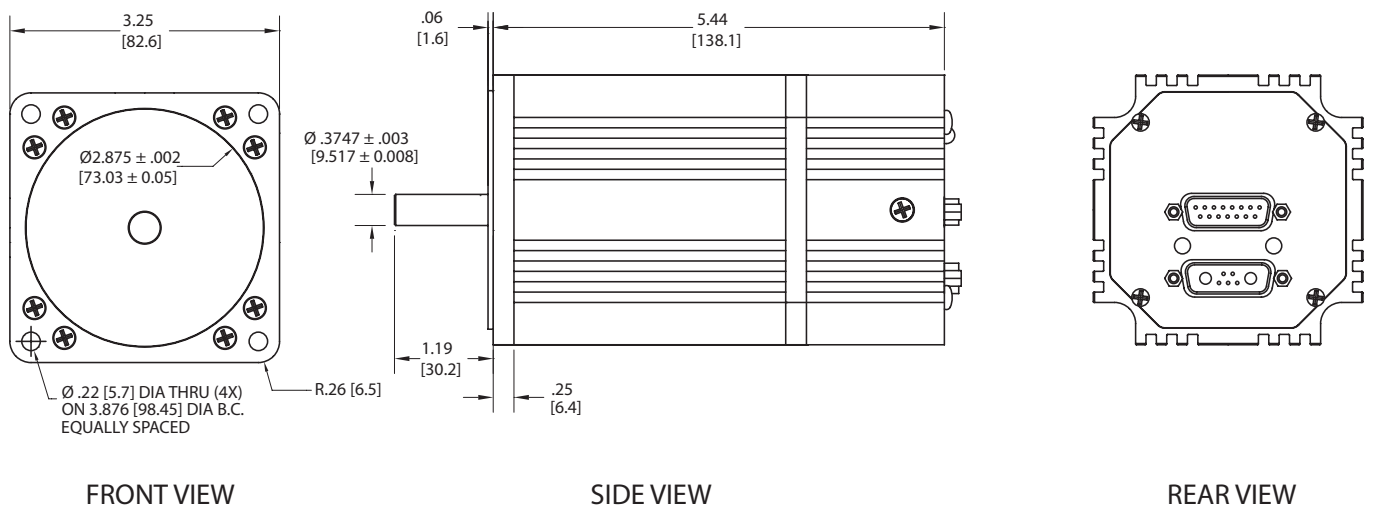

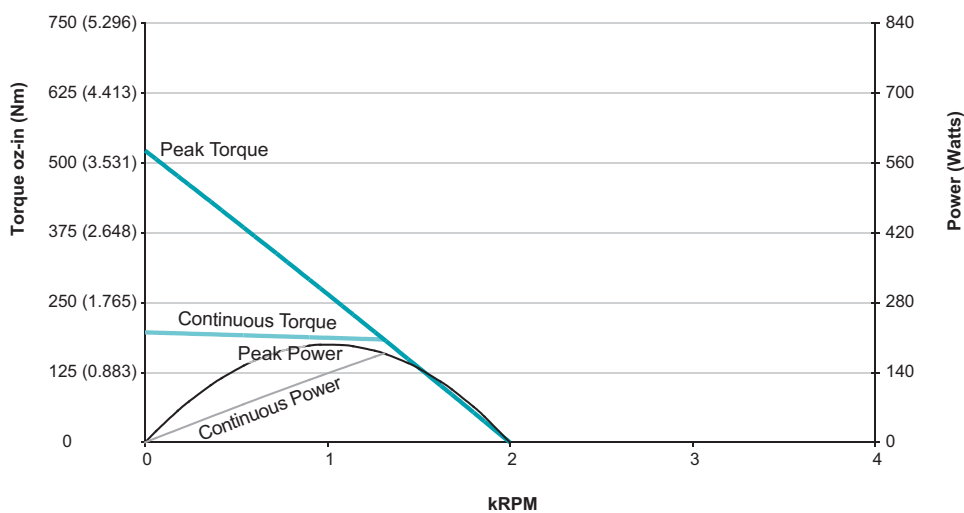
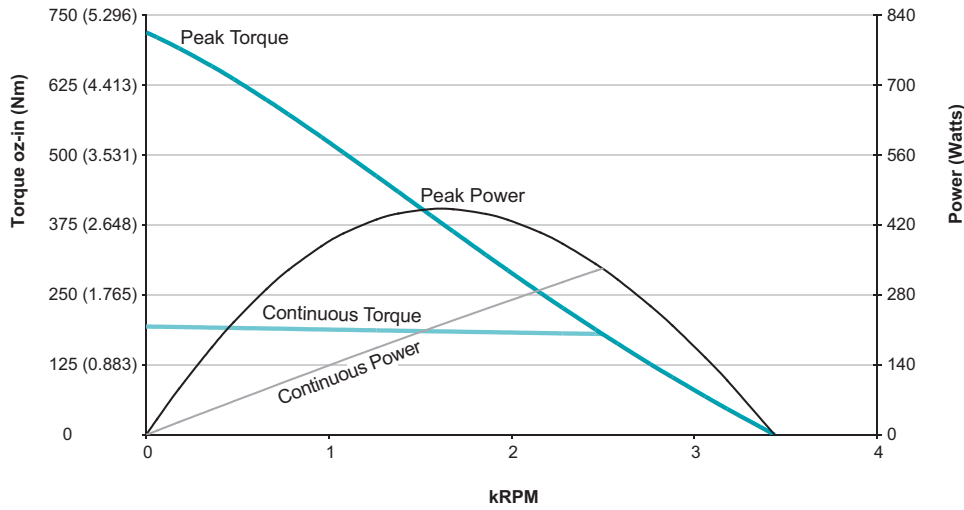
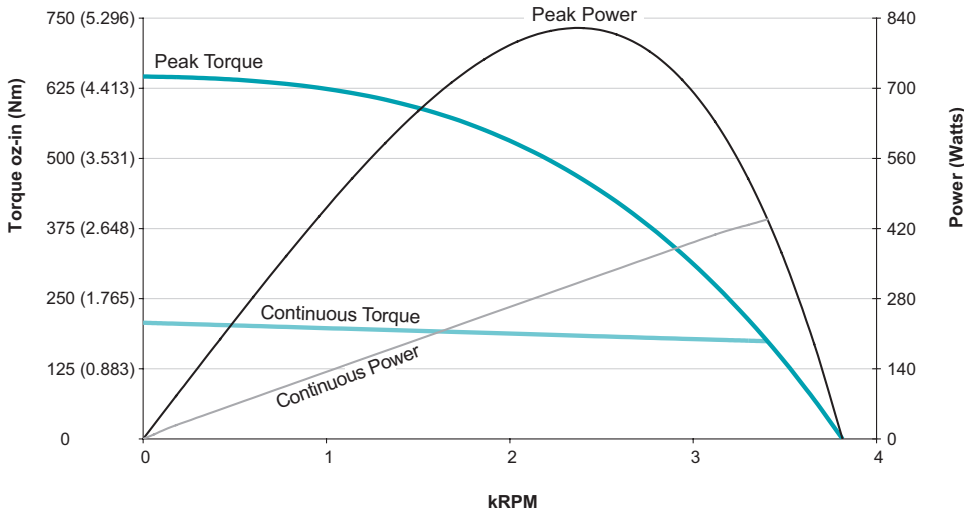

OVERVIEW
MOTOR SPECIFICATIONS
LINEAR SYSTEMS
CONNECTIVITY
PERIPHERALS
IP 65 MODELS & CONNECTIVITY
POWER SUPPLIES & SHUNTS
GEAR HEADS
SOFTWARE
APPENDIX

SM34505D		
Continuous Torque	16.34	in-lb
	261	oz-in
	1.85	N-m
Peak Torque	48.19	in-lb
	771	oz-in
	5.44	N-m
Nominal Continuous Power	527	Watt
No Load Speed	3,300	RPM
Continuous Current @ Nominal Power	14.1	Amps
Voltage Constant	13.7	V/kRPM
Winding Resistance	0.6	ohms
Encoder Resolution	8,000	Counts/Rev
Rotor Inertia	0.03	oz-in-sec ²
	21.192	10 ⁻⁵ Kg-m ²
Weight	6.5	lb
	2.95	kg
Shaft Diameter	0.375	in
	9.53	mm
Shaft, Radial Load	15	lb
	6.80	kg
Shaft, Axial Thrust Load	3	lb
	1.36	kg
DeviceNet Available	Yes	
ProfiBus Available		
CANopen Available	Yes	



Animatics SmartMotor SM34505D (No Options) CAD Drawing

in [mm]

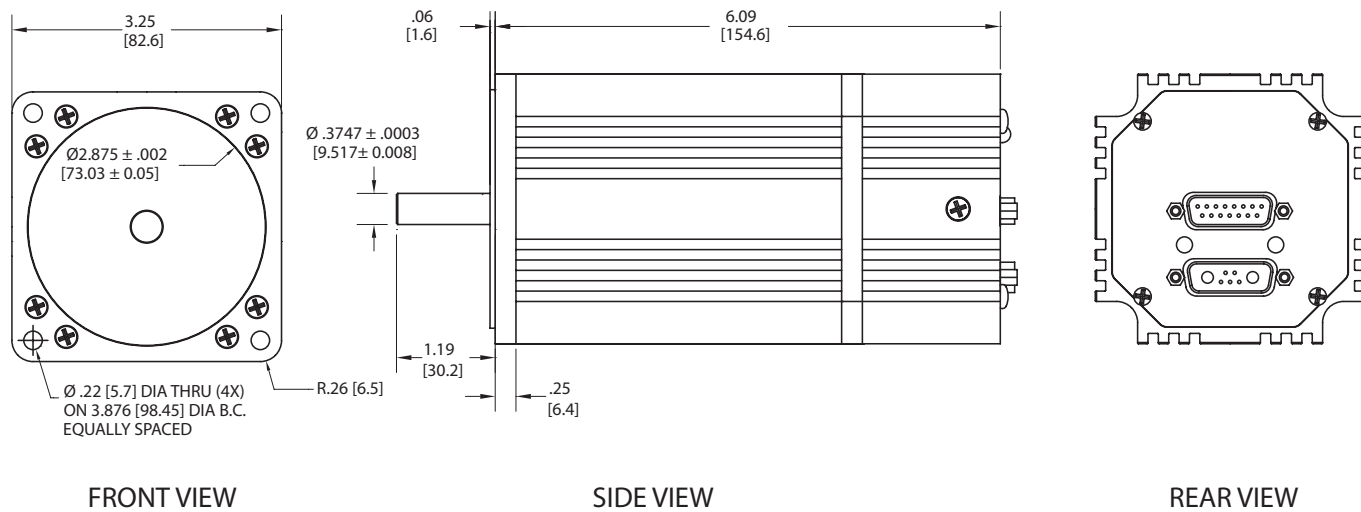

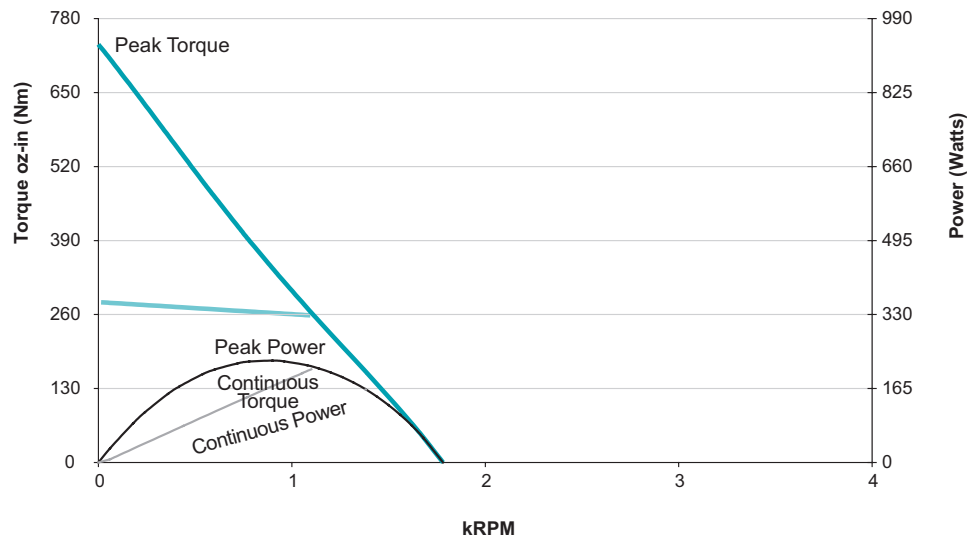
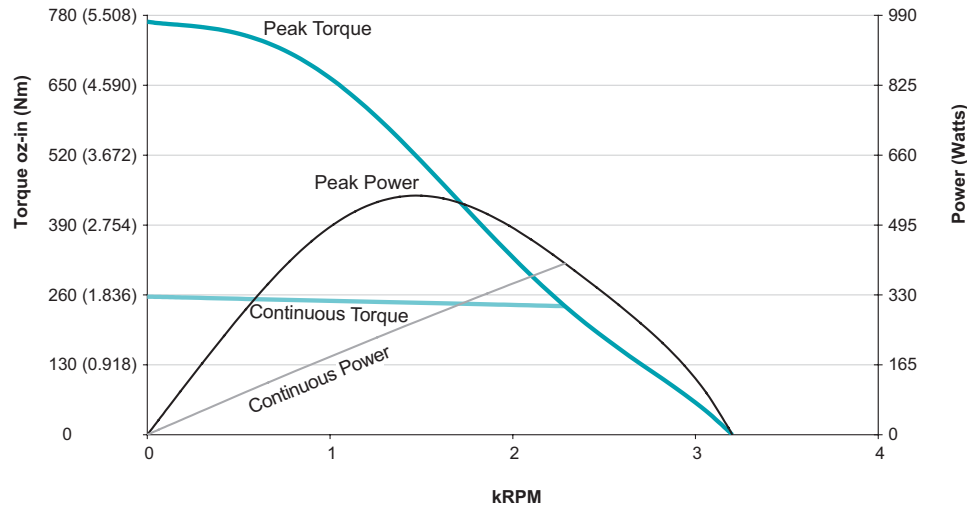
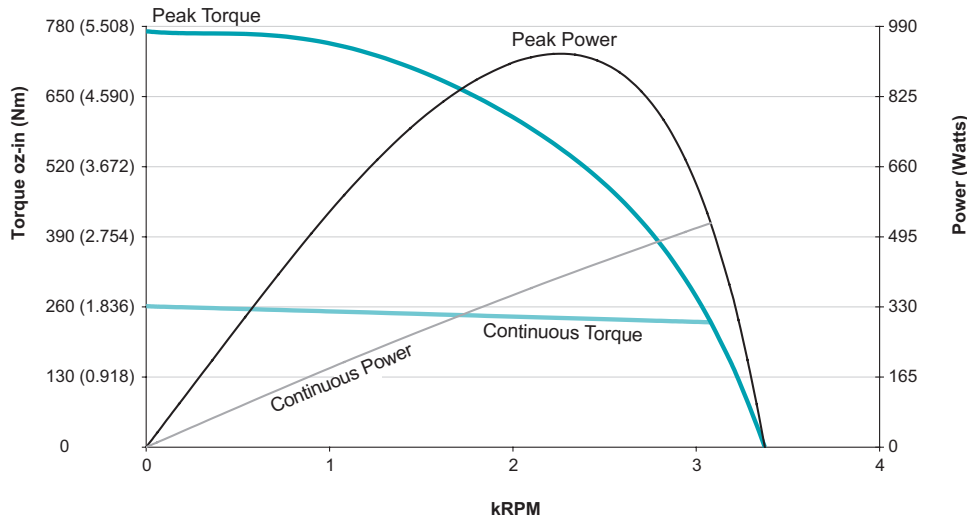

Animatics SmartMotor™ SM17205D

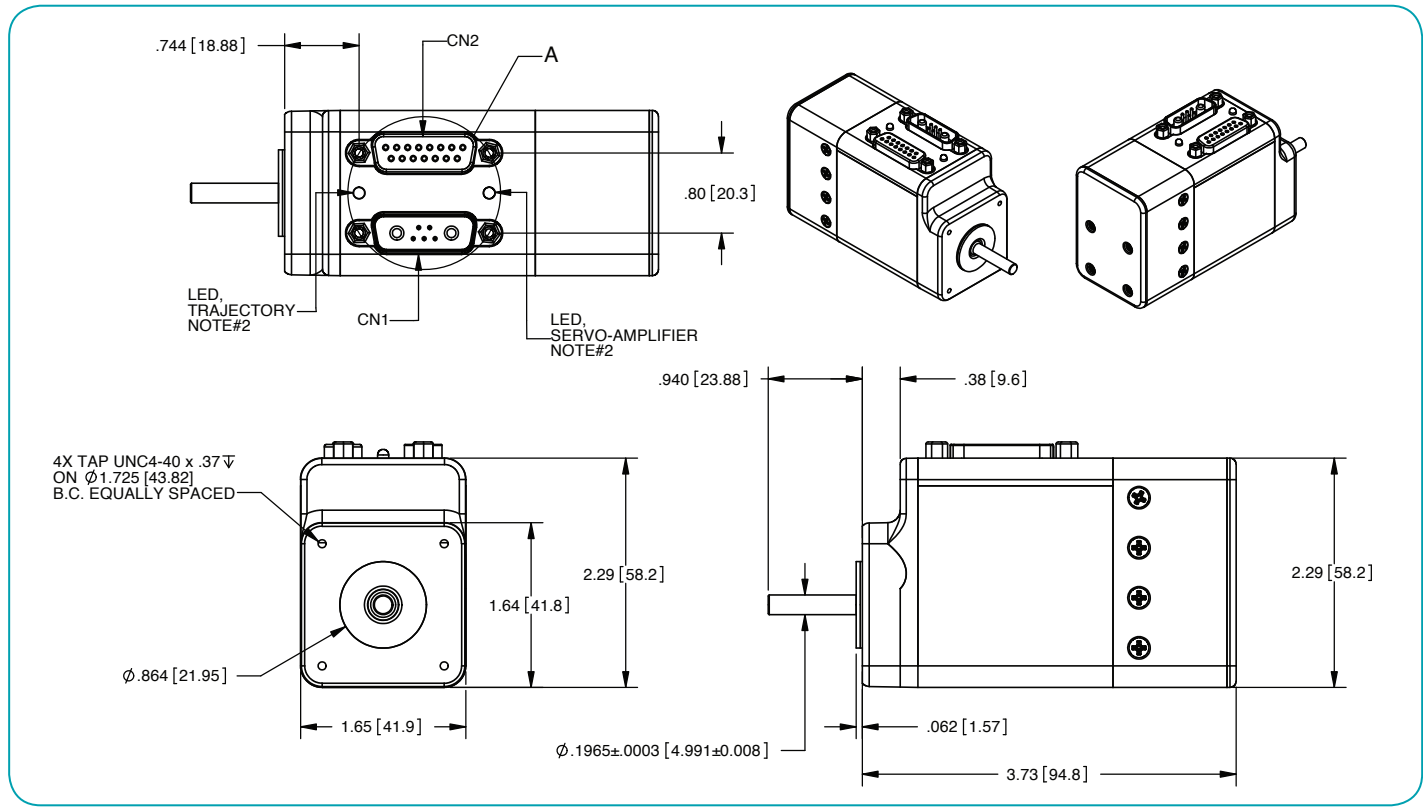

Animatics SmartMotor™ SM17205D-AD1

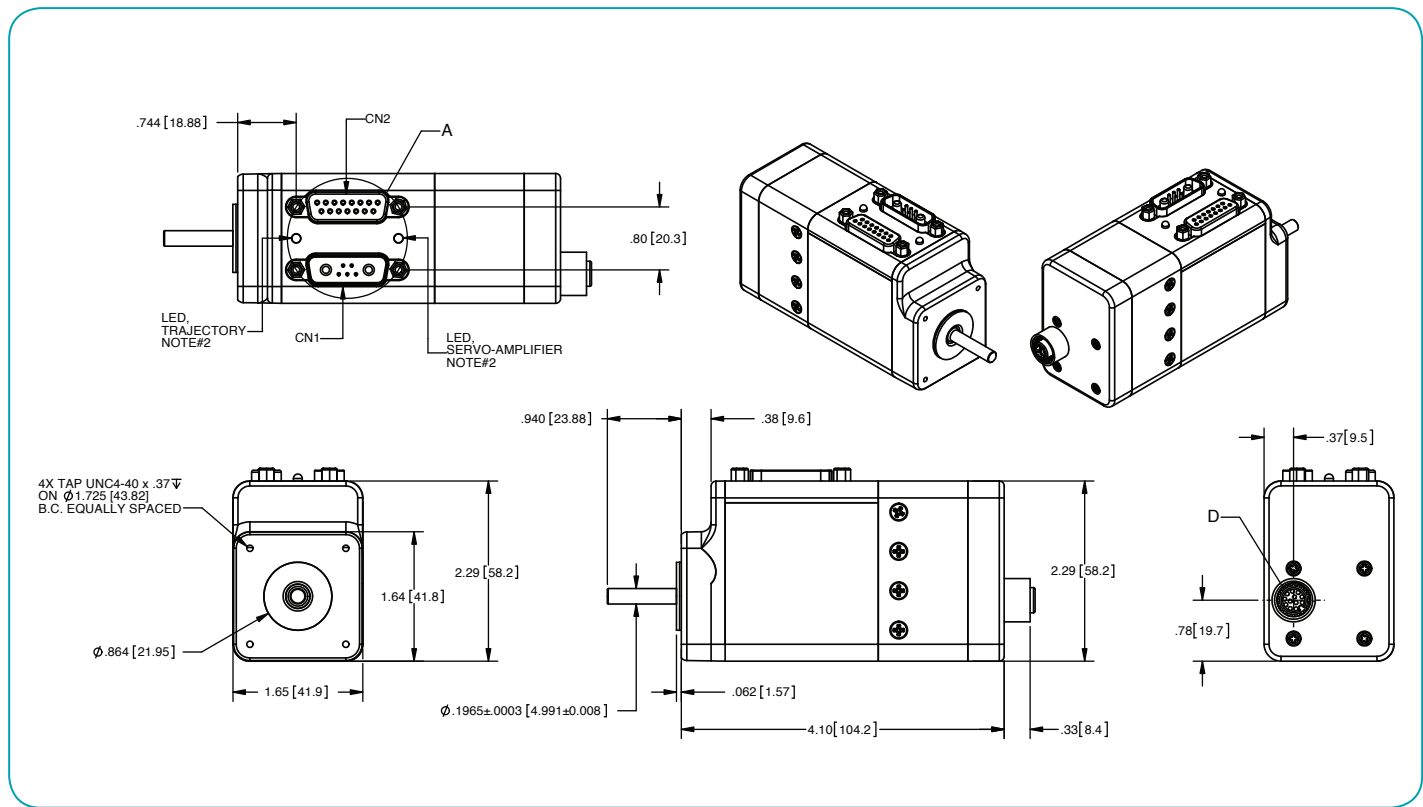

Animatics SmartMotor™ SM17205D-C

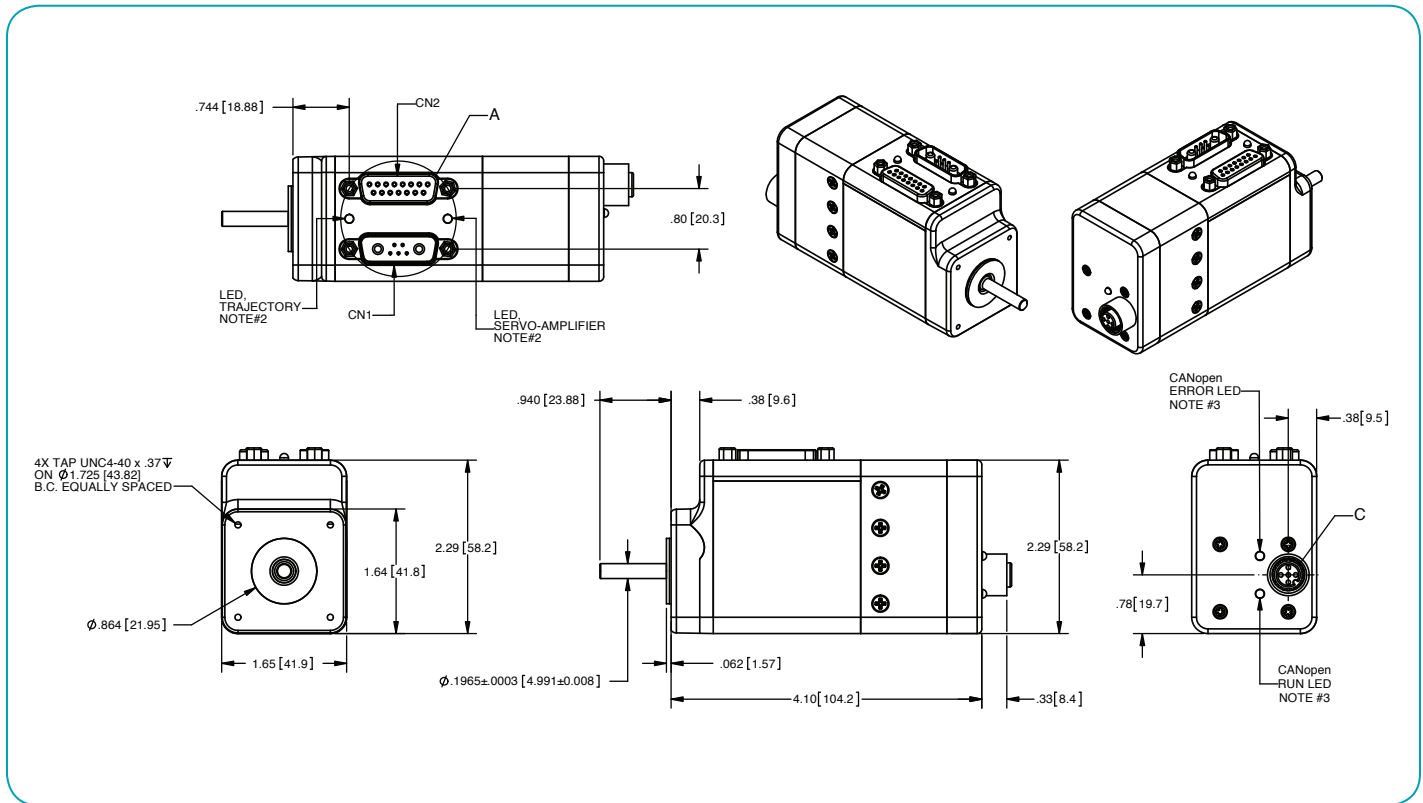

Animatics SmartMotor™ SM17205D-C-AD1

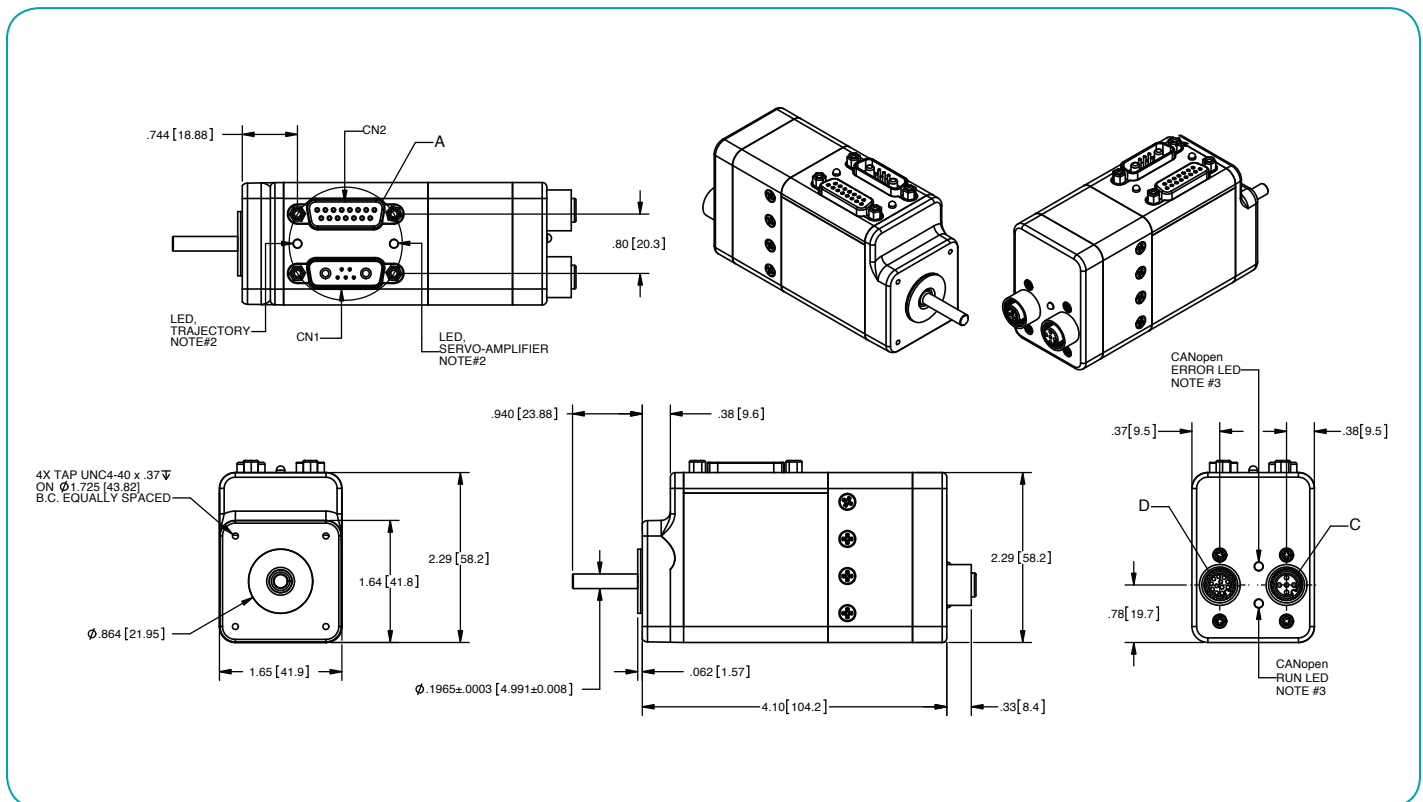

Animatics SmartMotor™ SM17205D-BRK

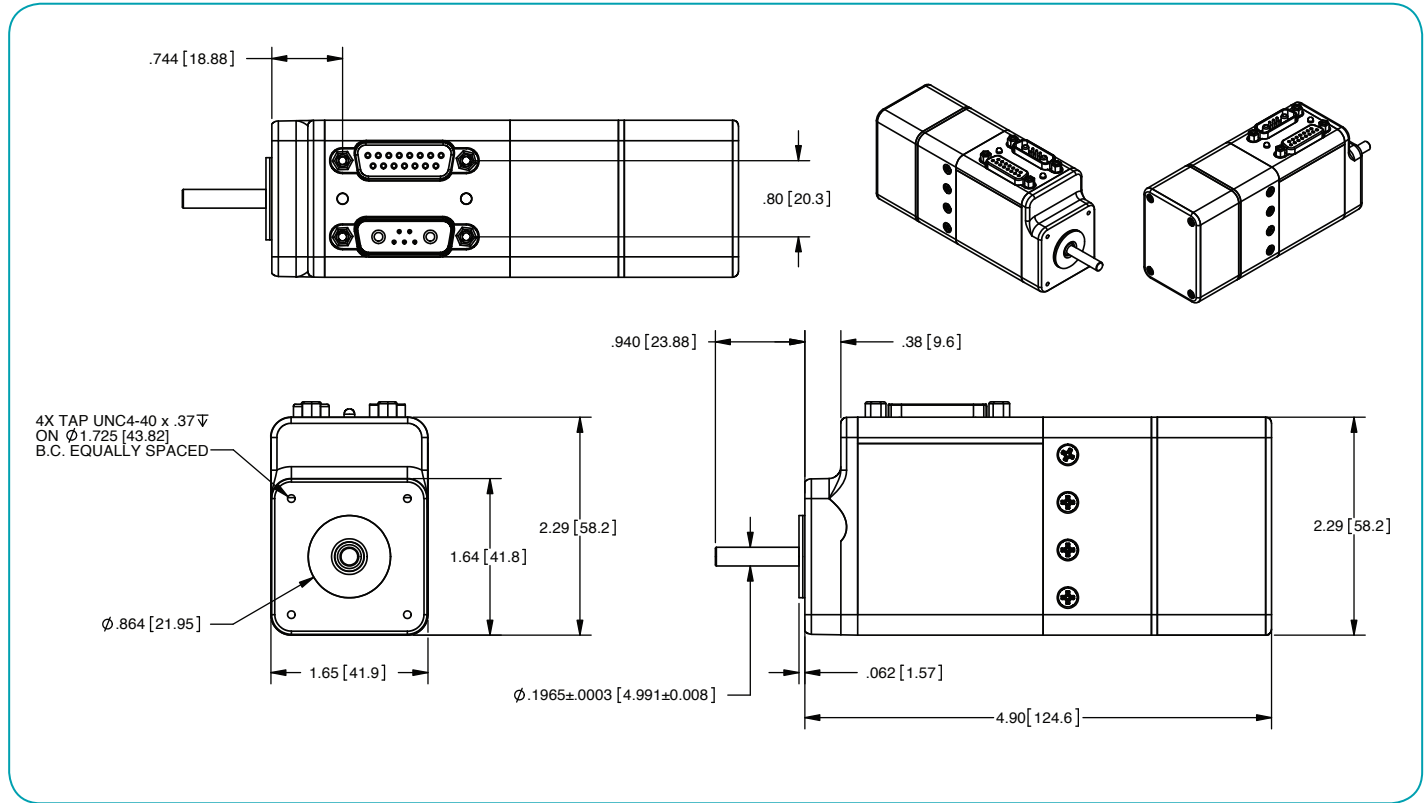

Animatics SmartMotor™ SM17205D-BRK-AD1

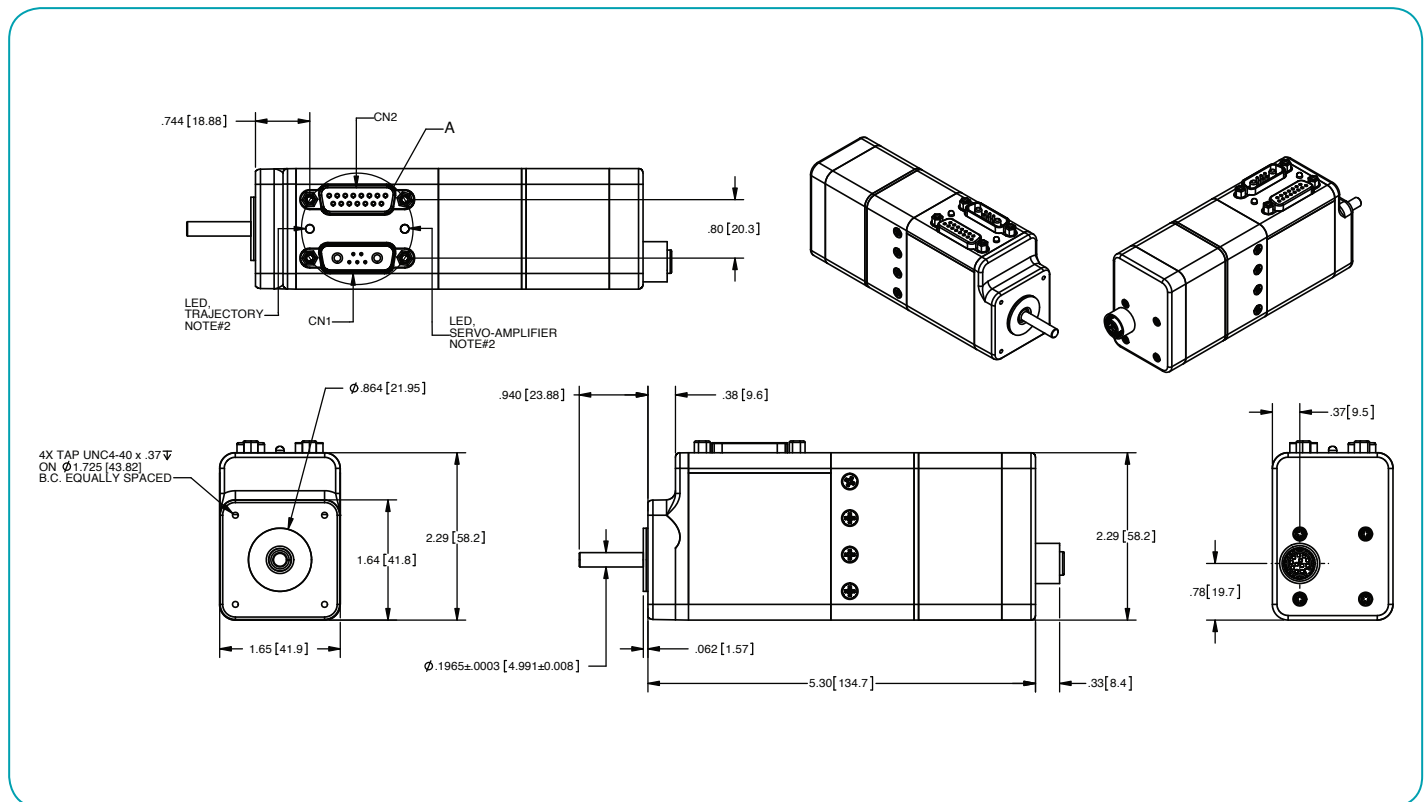

Animatics SmartMotor™ SM17205D-BRK-C

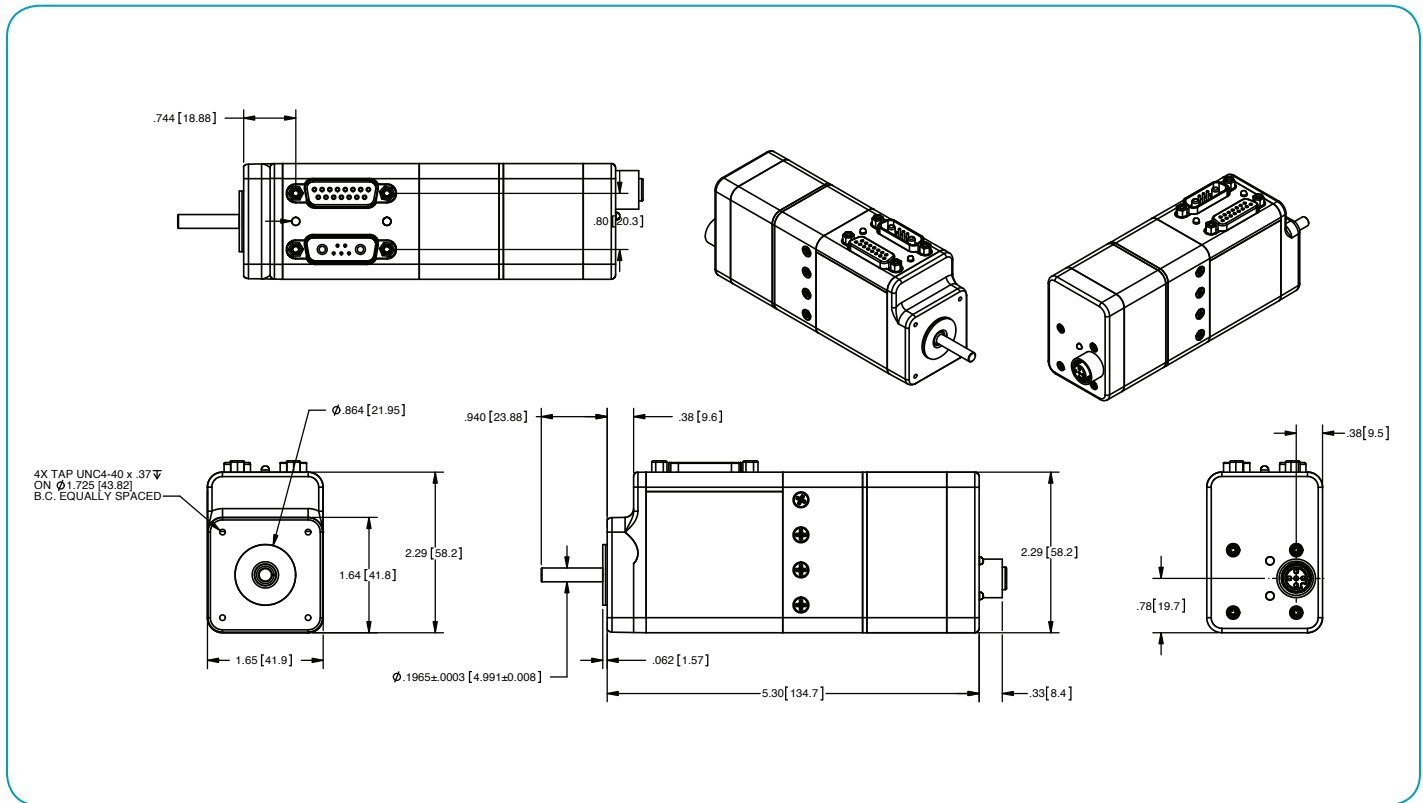

Animatics SmartMotor™ SM17205D-BRK -C-AD1

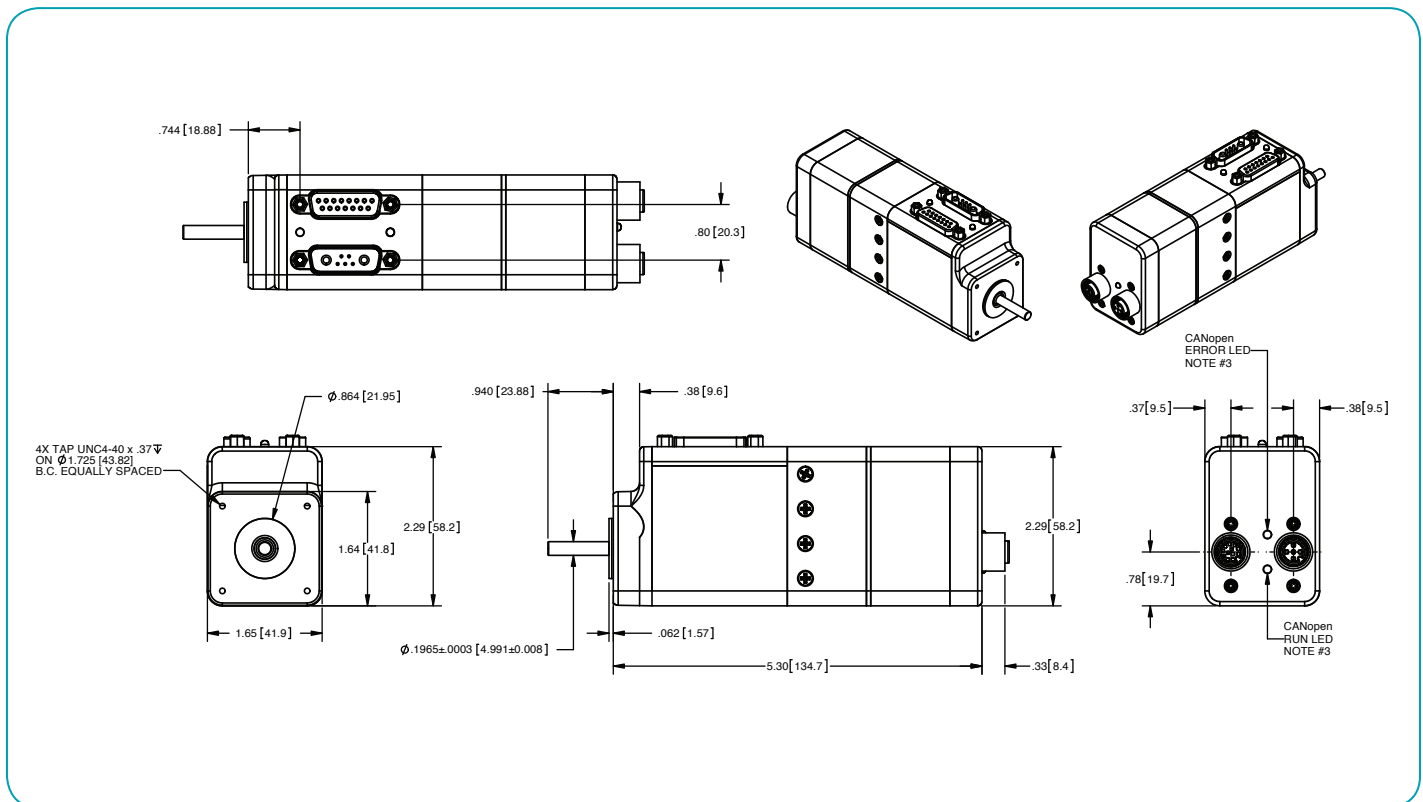

Animatics SmartMotor™ SM23165D/DT-AD1

in [mm]

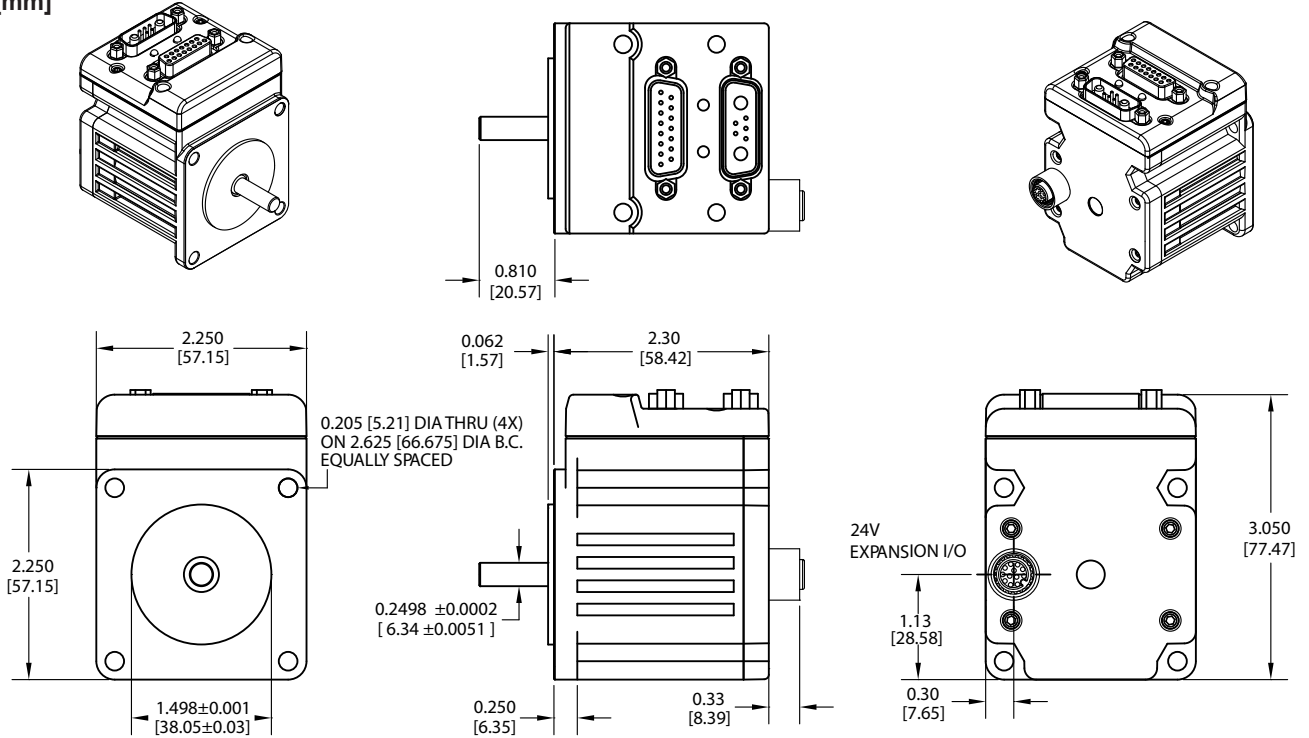

Animatics SmartMotor™ SM23165D/DT-C

in [mm]

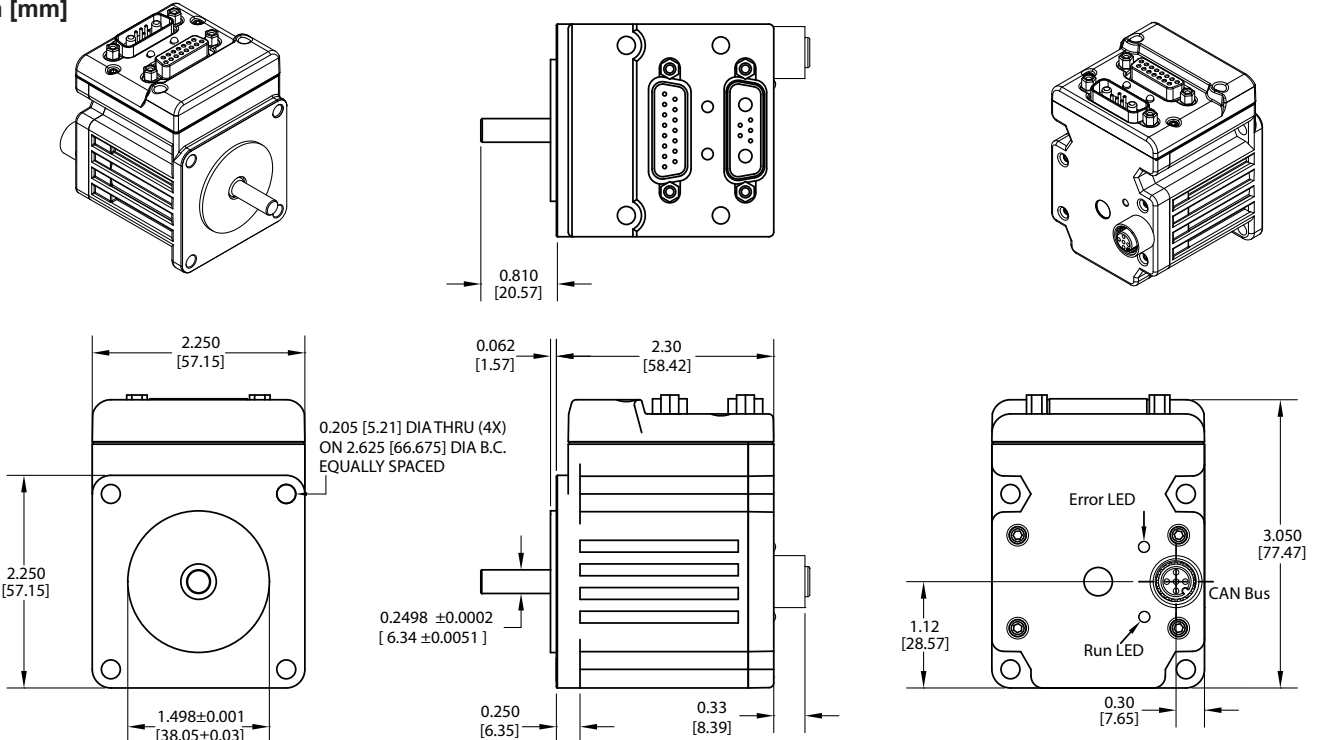

Animatics SmartMotor™ SM23165D/DT-C-AD1

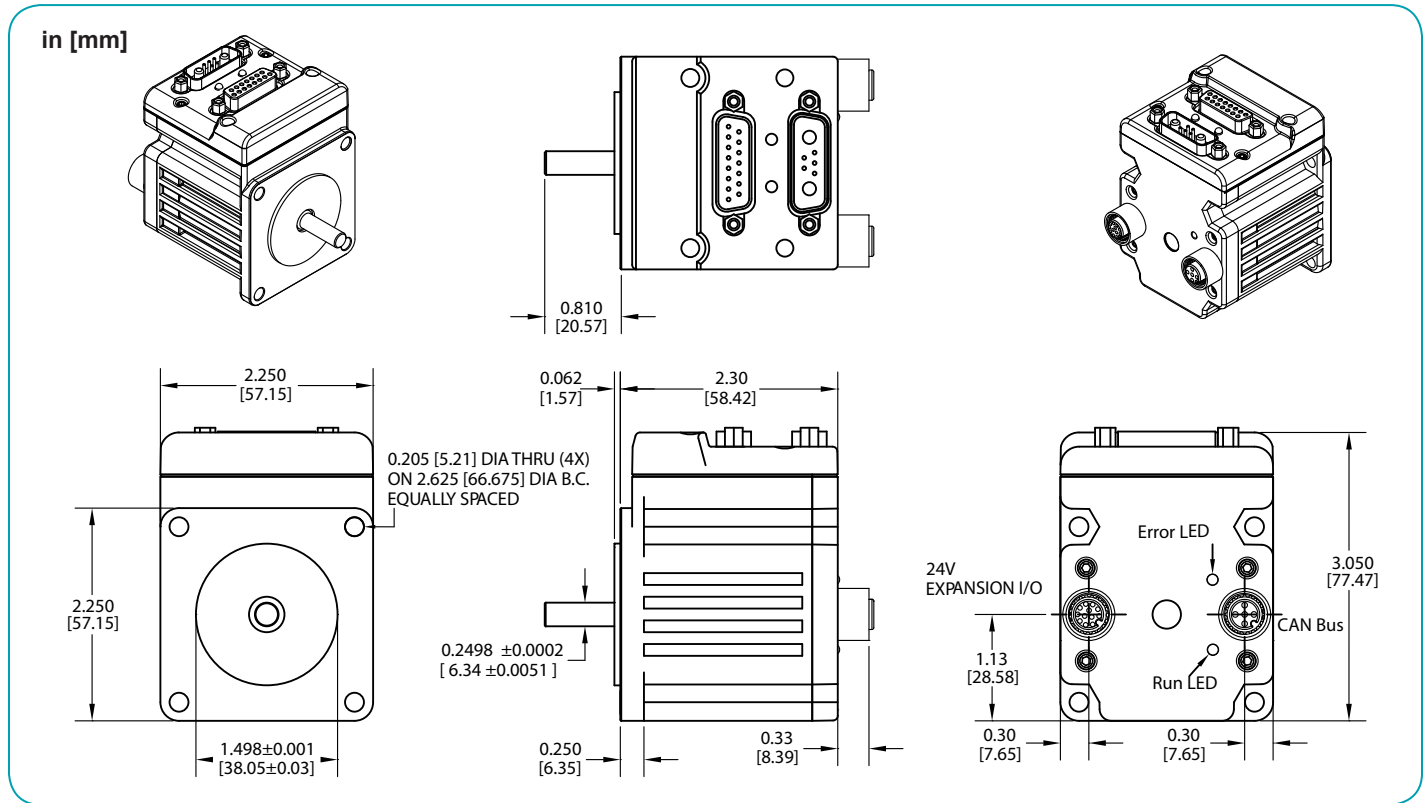

Animatics SmartMotor™ SM23165D/DT-BRK

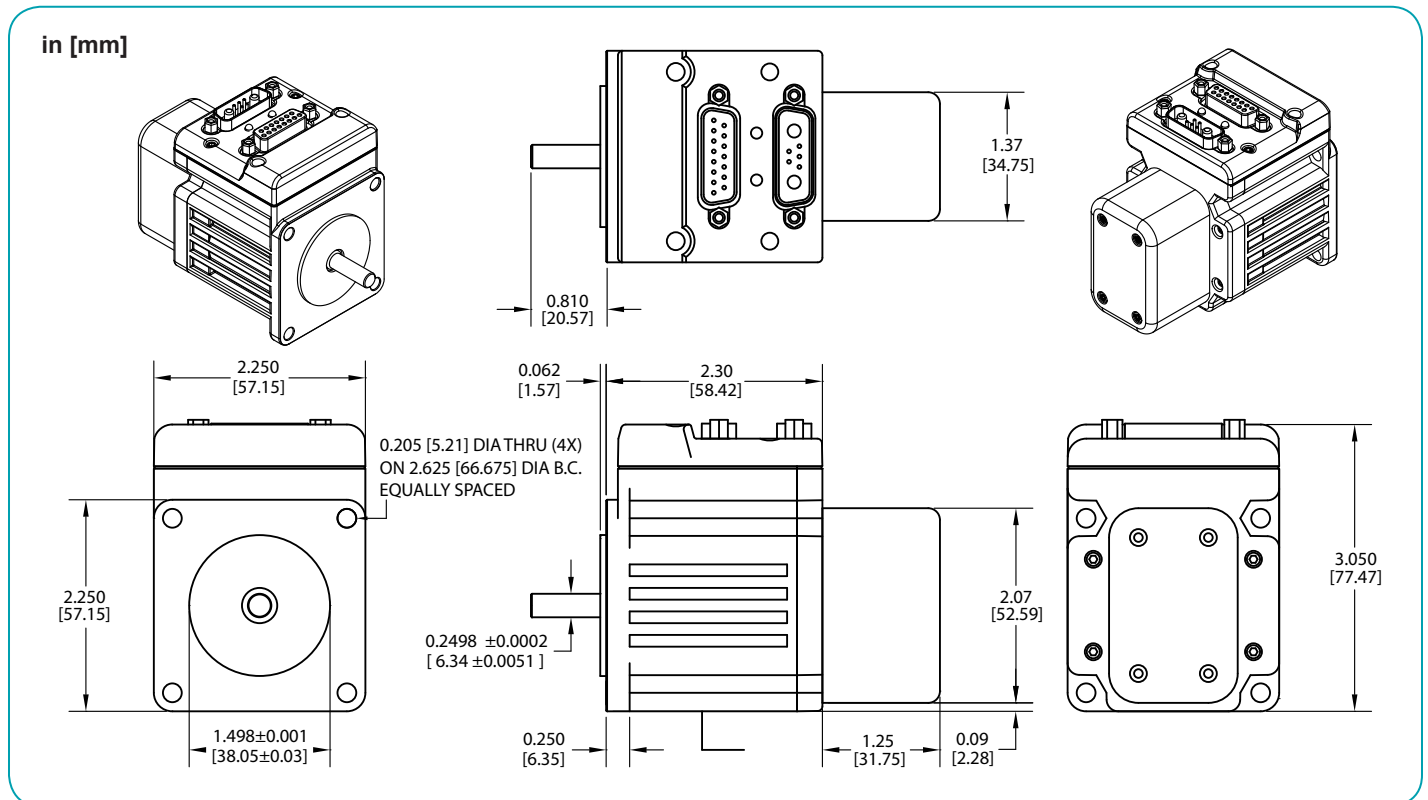

Animatics SmartMotor™ SM23x05D-AD1

in [mm]

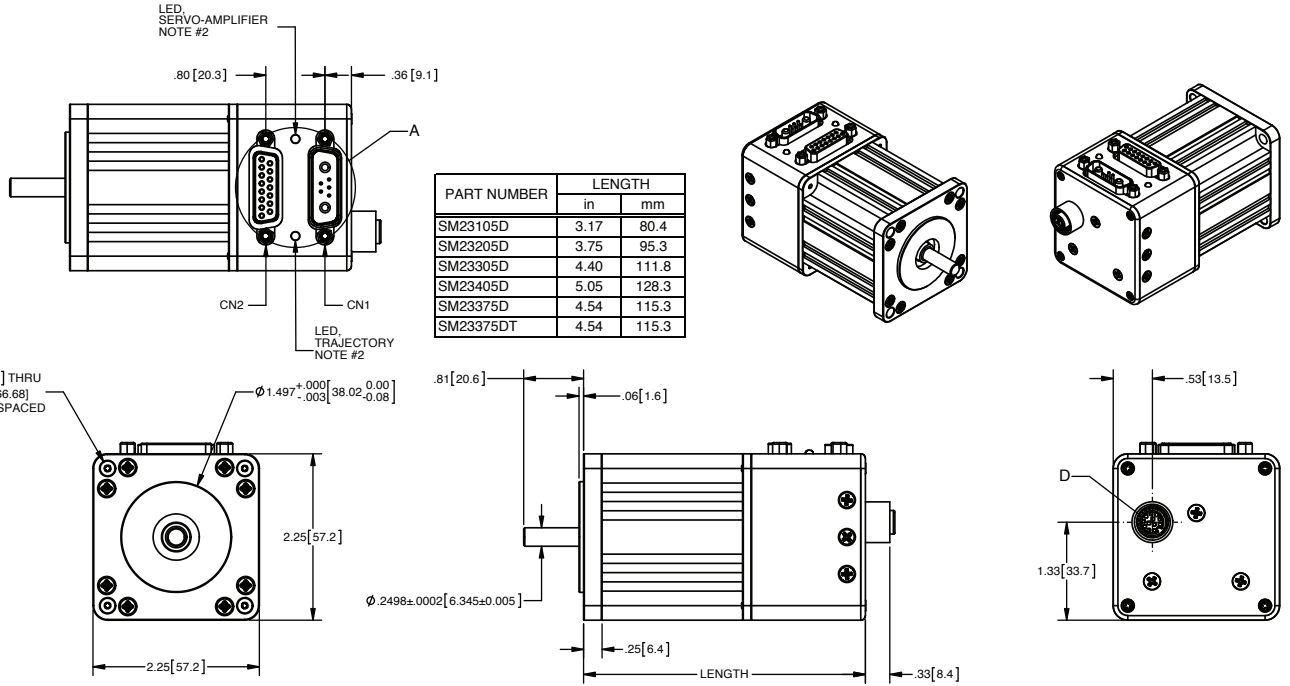

Animatics SmartMotor™ SM23x05D-C

in [mm]

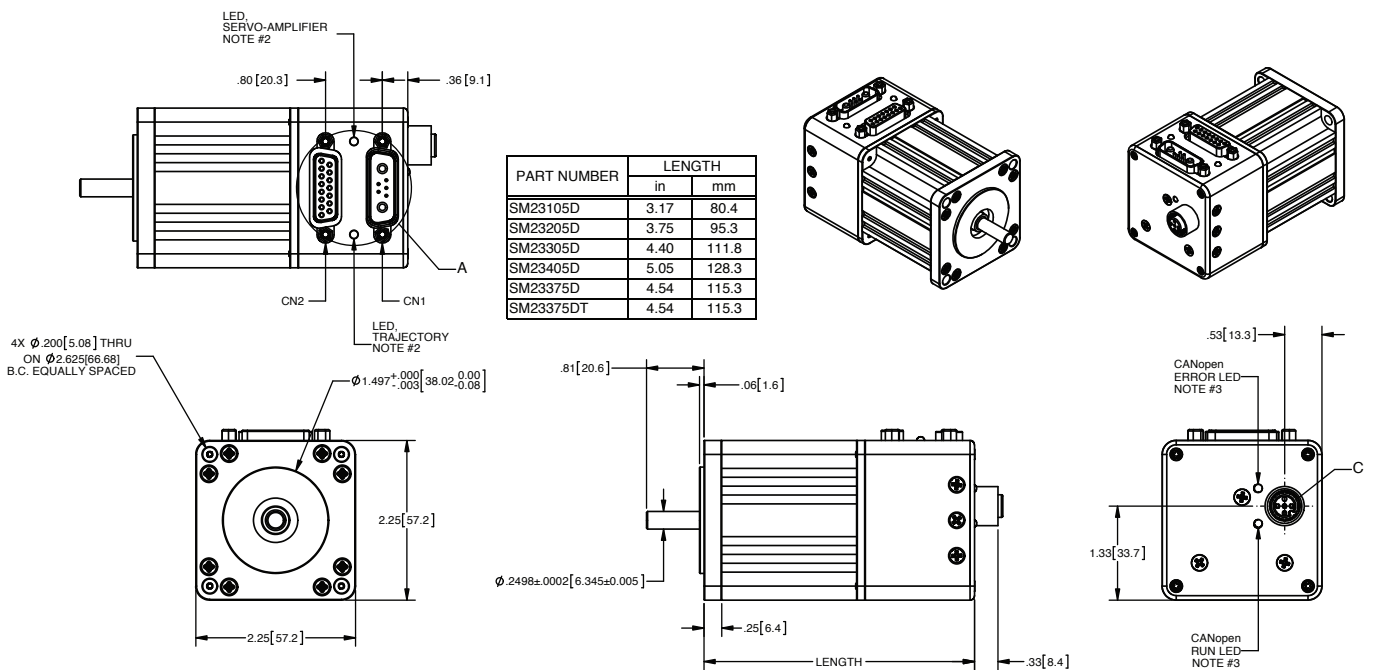

Animatics SmartMotor™ SM23x05D-C-AD1

in [mm]

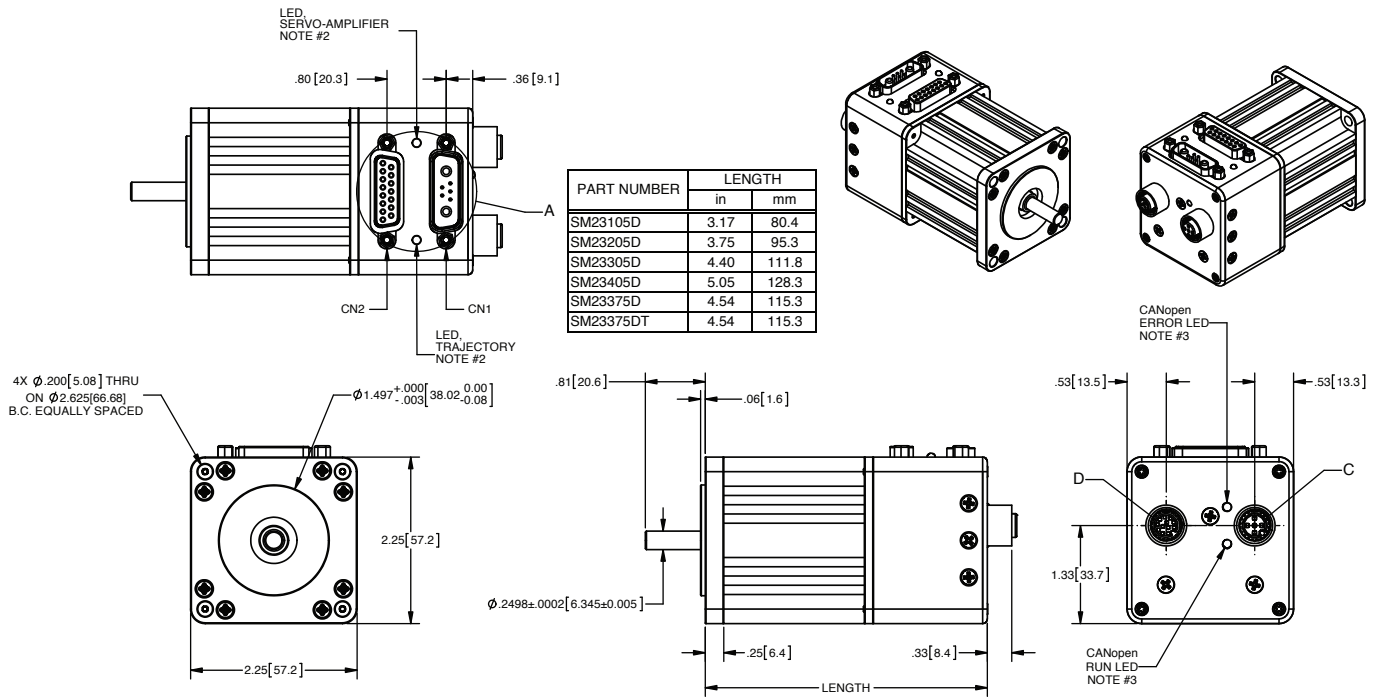

Animatics SmartMotor™ SM23x05D-BRK

in [mm]

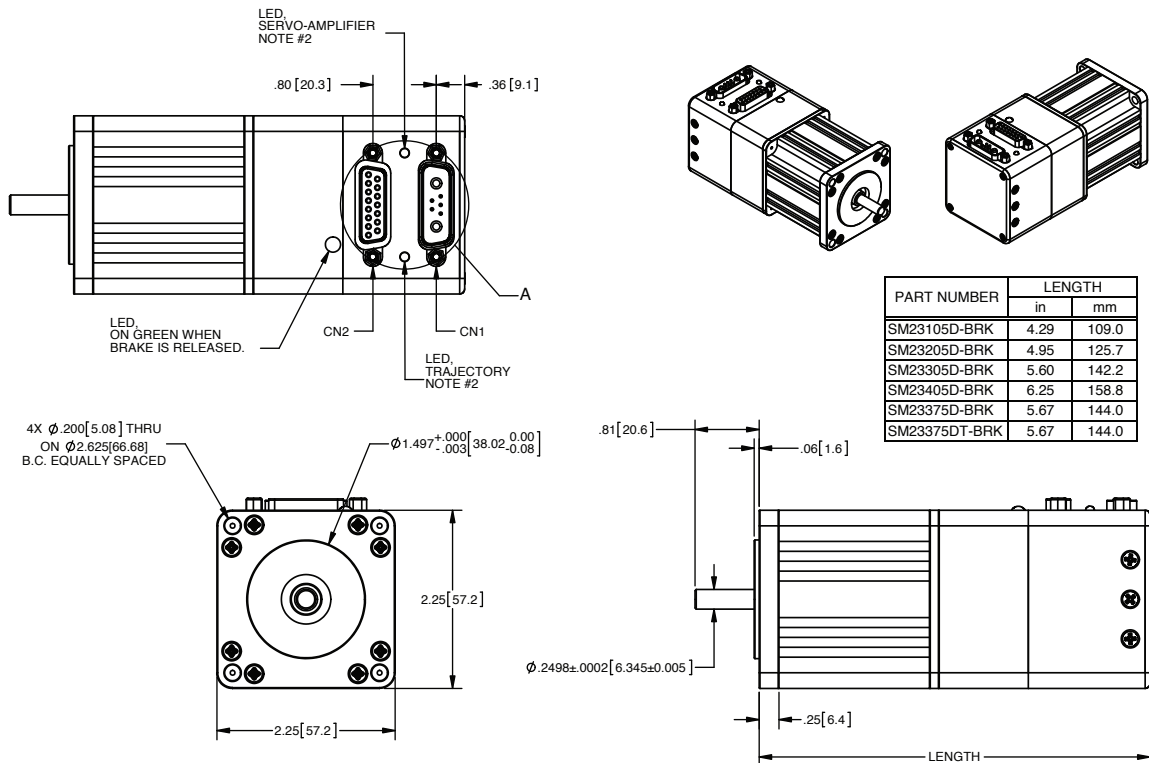

Animatics SmartMotor™ SM23x05D-BRK-AD1

in [mm]

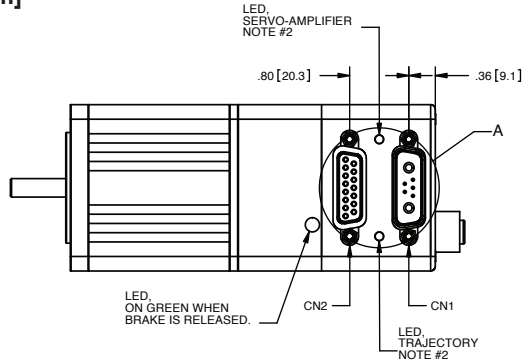

PART NUMBER	LENGTH	
	in	mm
SM23105D-BRK	4.29	109.0
SM23205D-BRK	4.95	125.7
SM23305D-BRK	5.60	142.2
SM23405D-BRK	6.25	158.8
SM23375D-BRK	5.67	144.0
SM23375DT-BRK	5.67	144.0

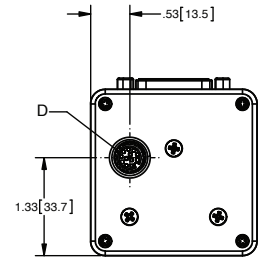
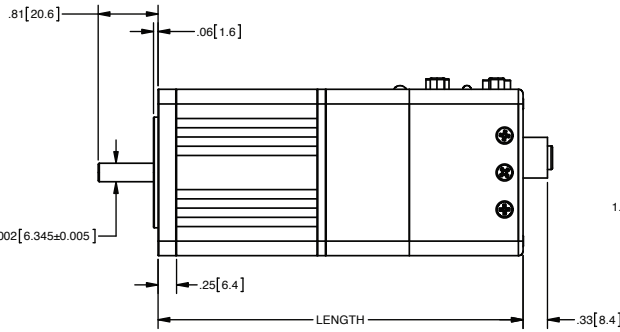
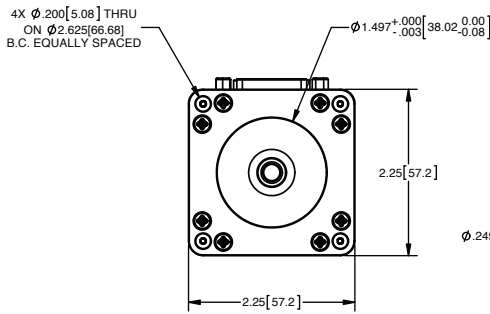
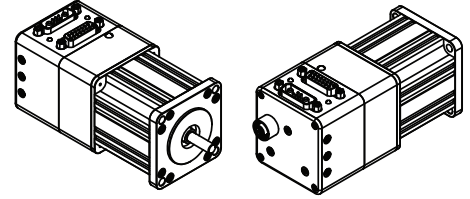

Animatics SmartMotor™ SM23x05D-BRK-C

in [mm]

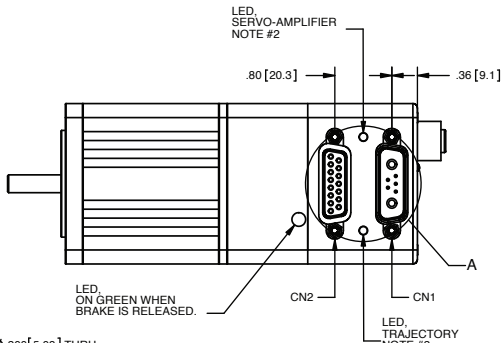

PART NUMBER	LENGTH	
	in	mm
SM23105D-BRK	4.29	109.0
SM23205D-BRK	4.95	125.7
SM23305D-BRK	5.60	142.2
SM23405D-BRK	6.25	158.8
SM23375D-BRK	5.67	144.0
SM23375DT-BRK	5.67	144.0

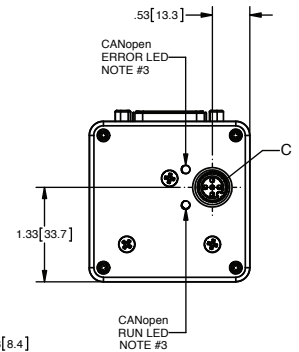
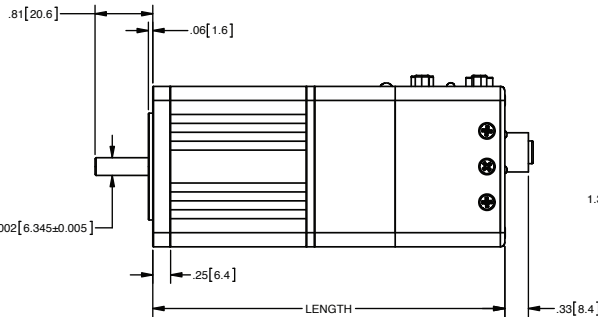
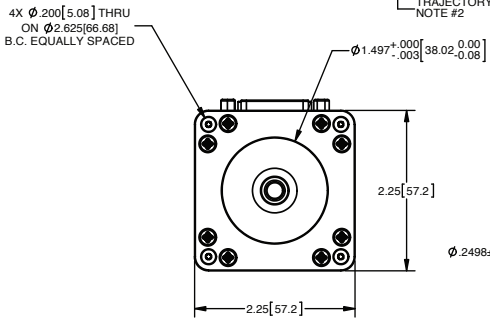
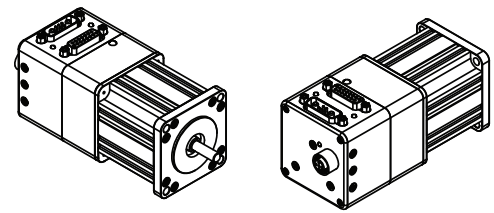

Animatics SmartMotor™ SM23x05D-BRK-C-AD1

in [mm]

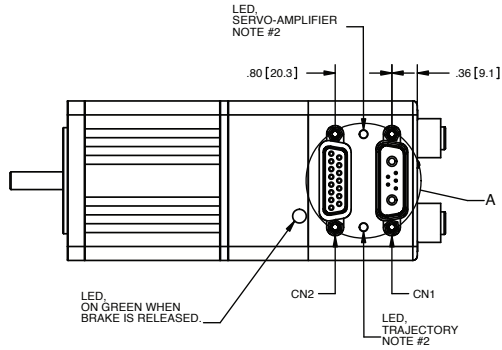

PART NUMBER	LENGTH	
	in	mm
SM23105D-BRK	4.29	109.0
SM23205D-BRK	4.95	125.7
SM23305D-BRK	5.60	142.2
SM23405D-BRK	6.25	158.8
SM23375D-BRK	5.67	144.0
SM23375DT-BRK	5.67	144.0

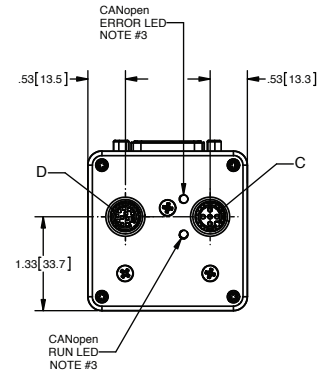
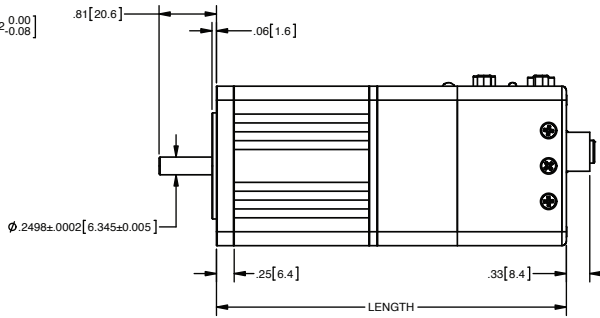
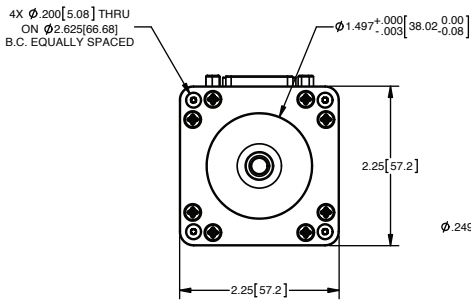
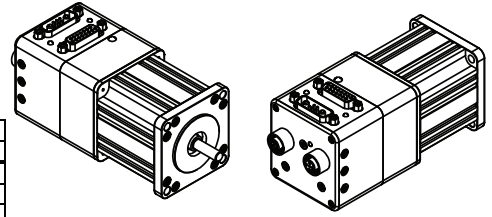

Animatics SmartMotor™ SM34165DT-AD1

in [mm]

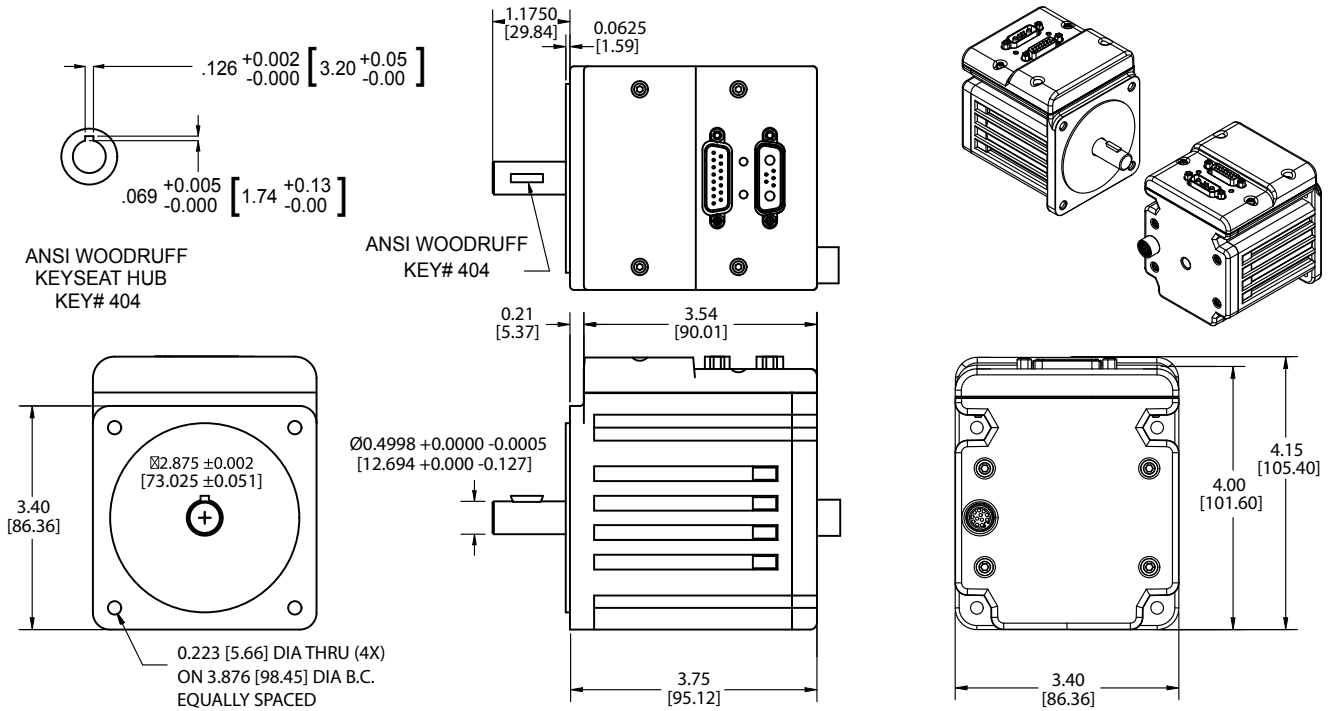

Animatics SmartMotor™ SM34165DT-C

in [mm]

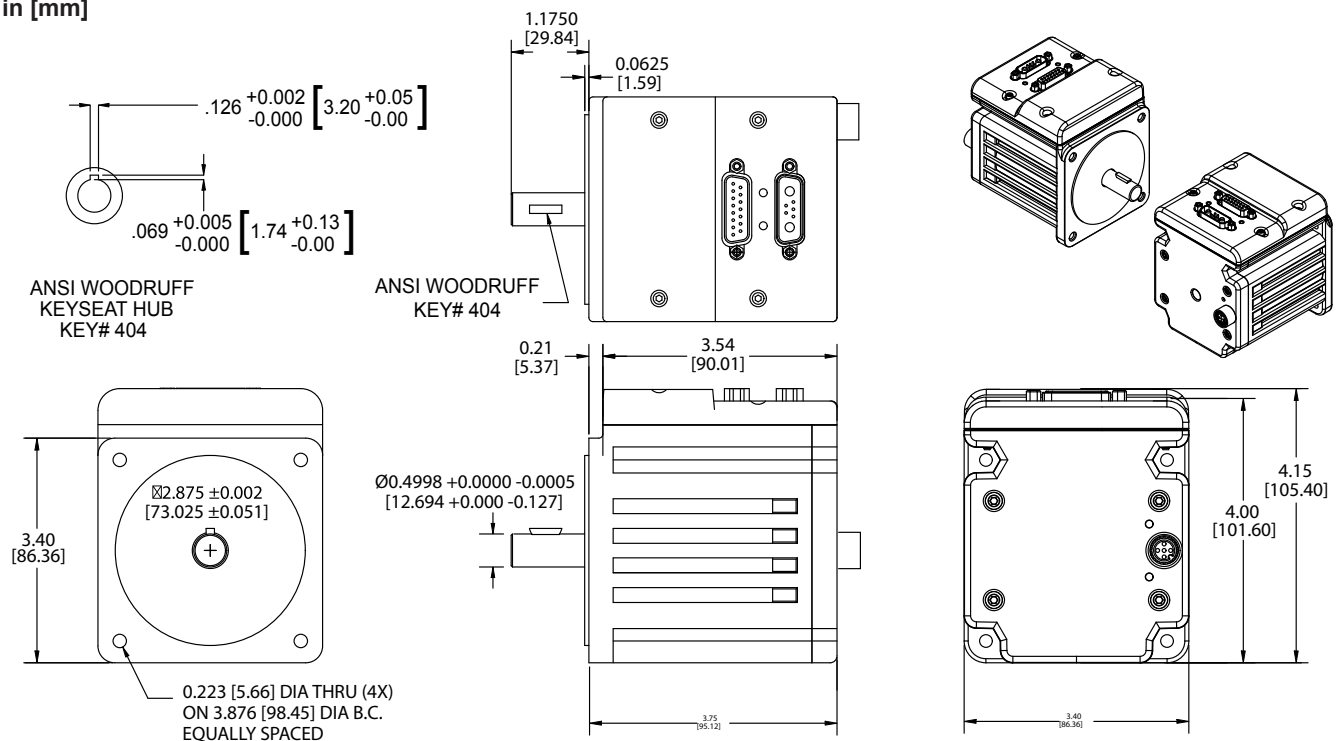

Animatics SmartMotor™ SM34165DT-C-AD1

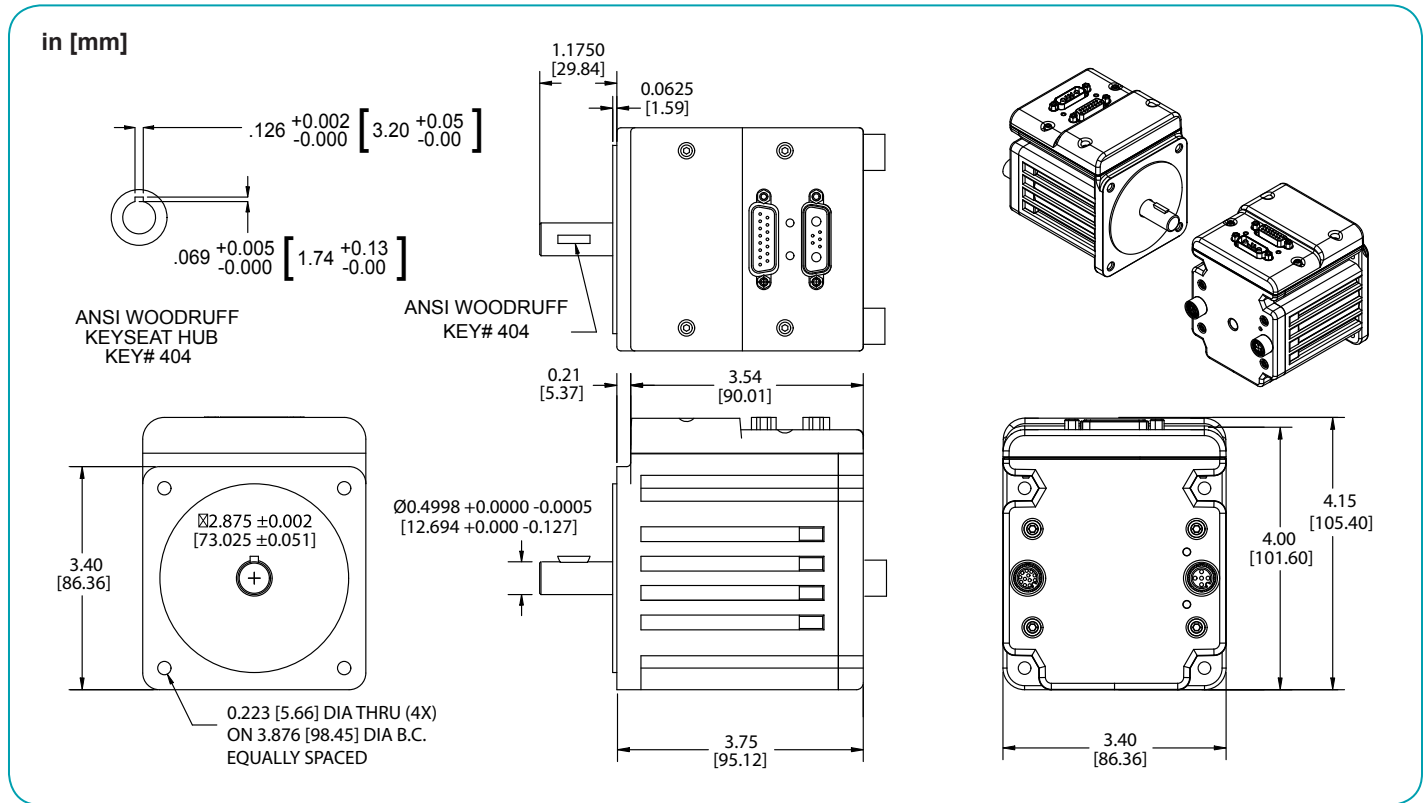

Animatics SmartMotor™ SM34165DT-BRK

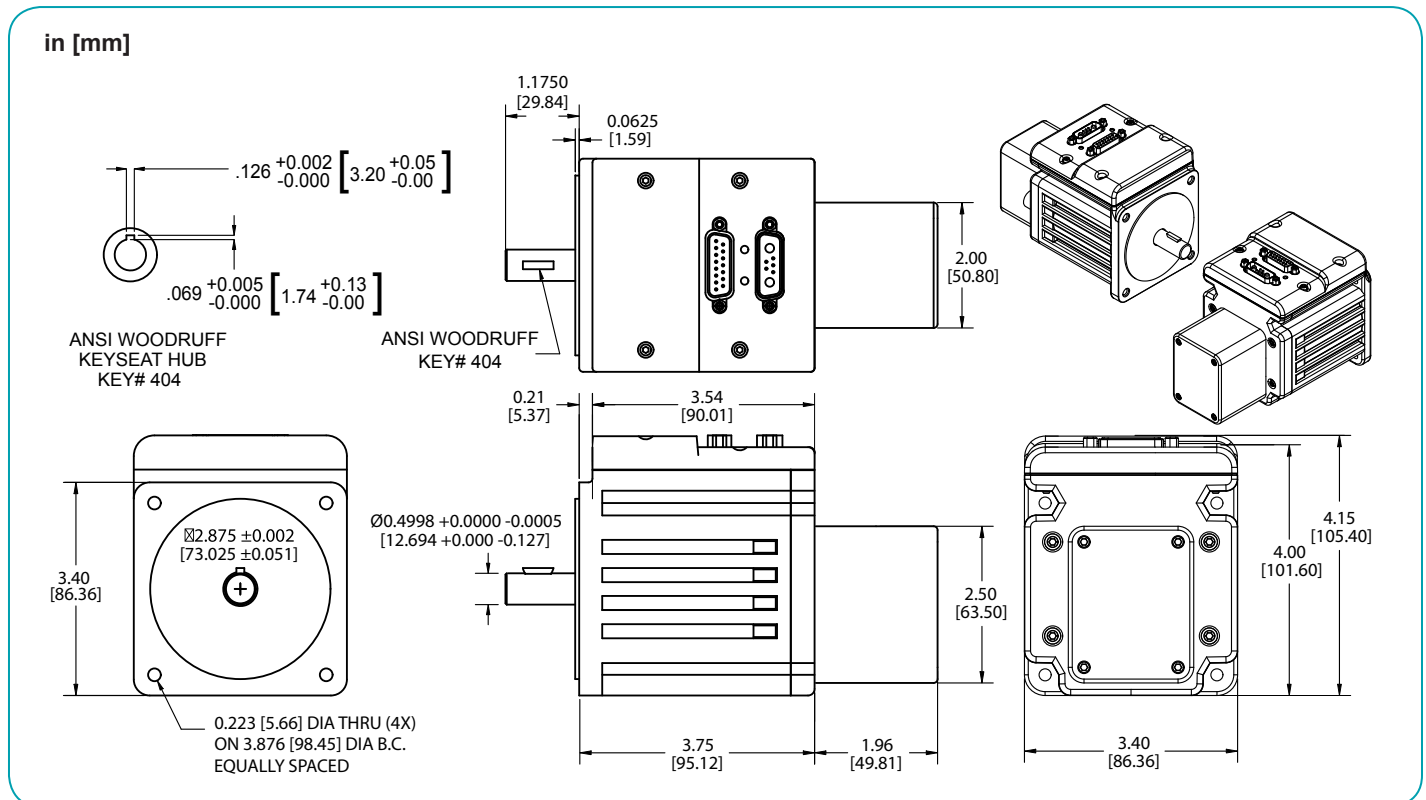

Animatics SmartMotor™ SM34165DT-BRK-AD1

in [mm]

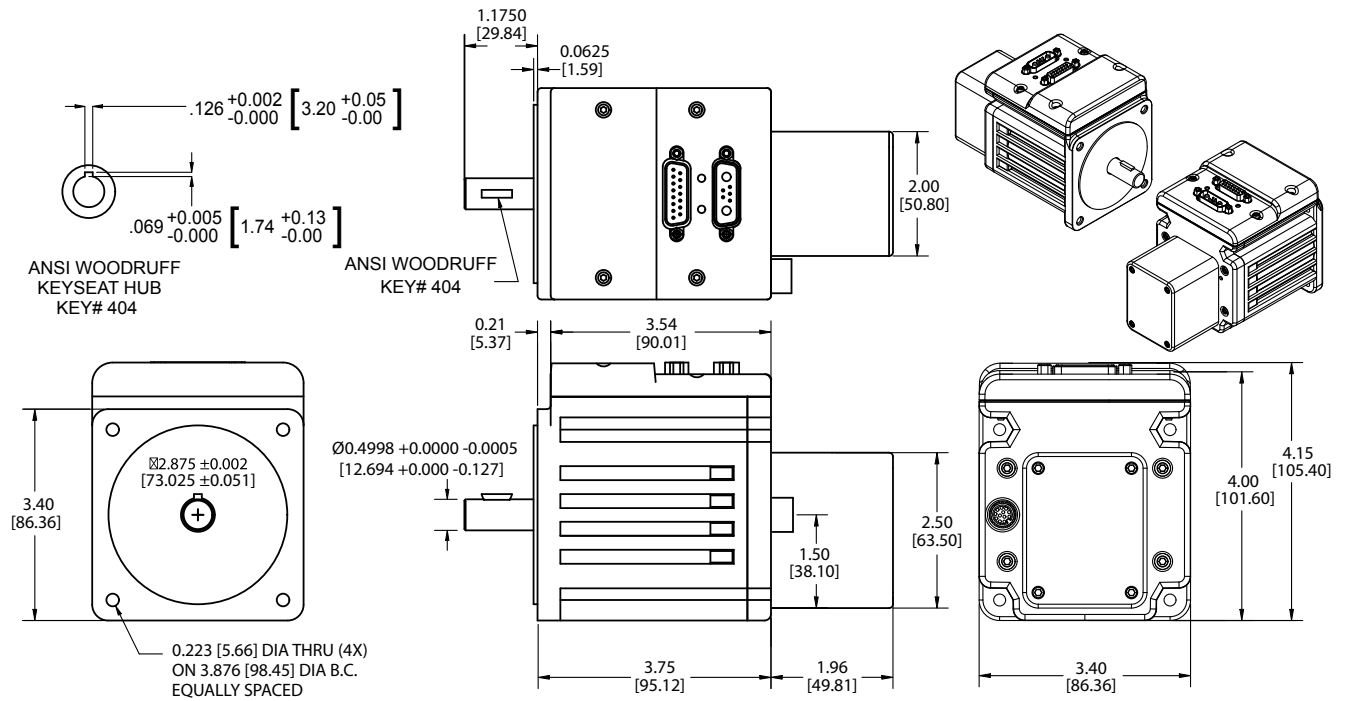

Animatics SmartMotor™ SM34165DT-BRK-C

in [mm]

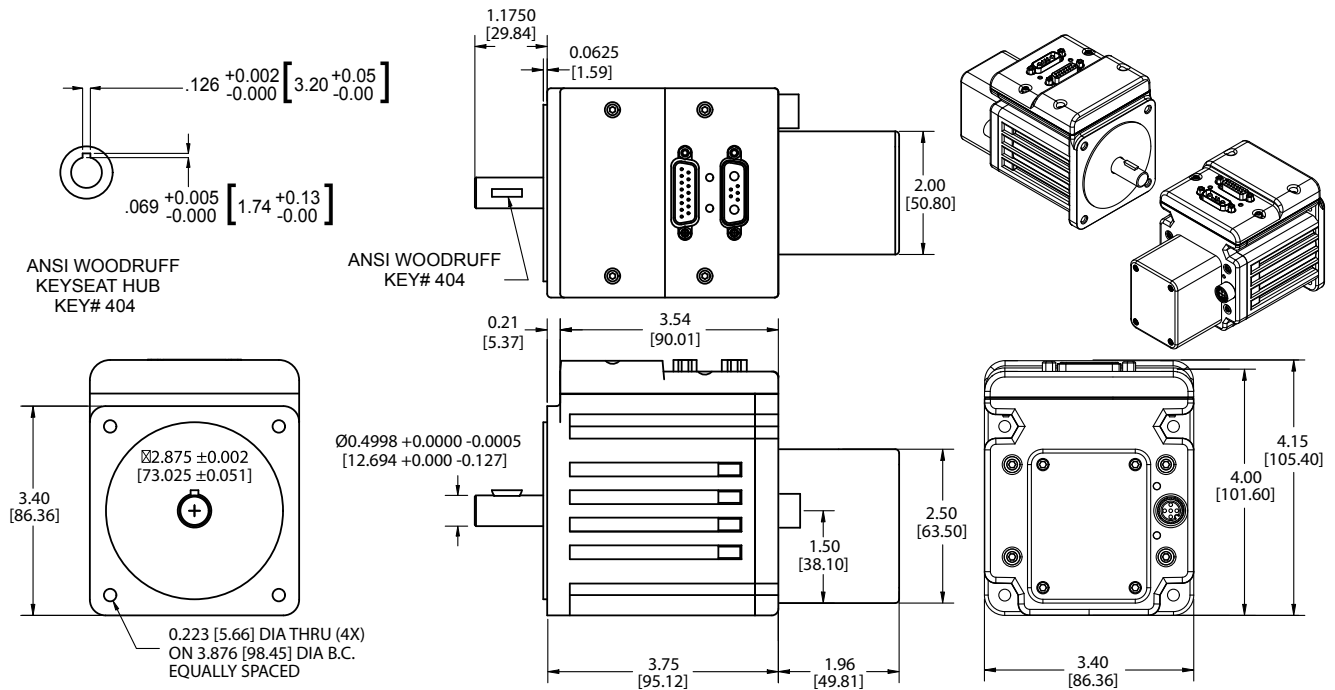

Animatics SmartMotor™ SM34165DT-BRK-C-AD1

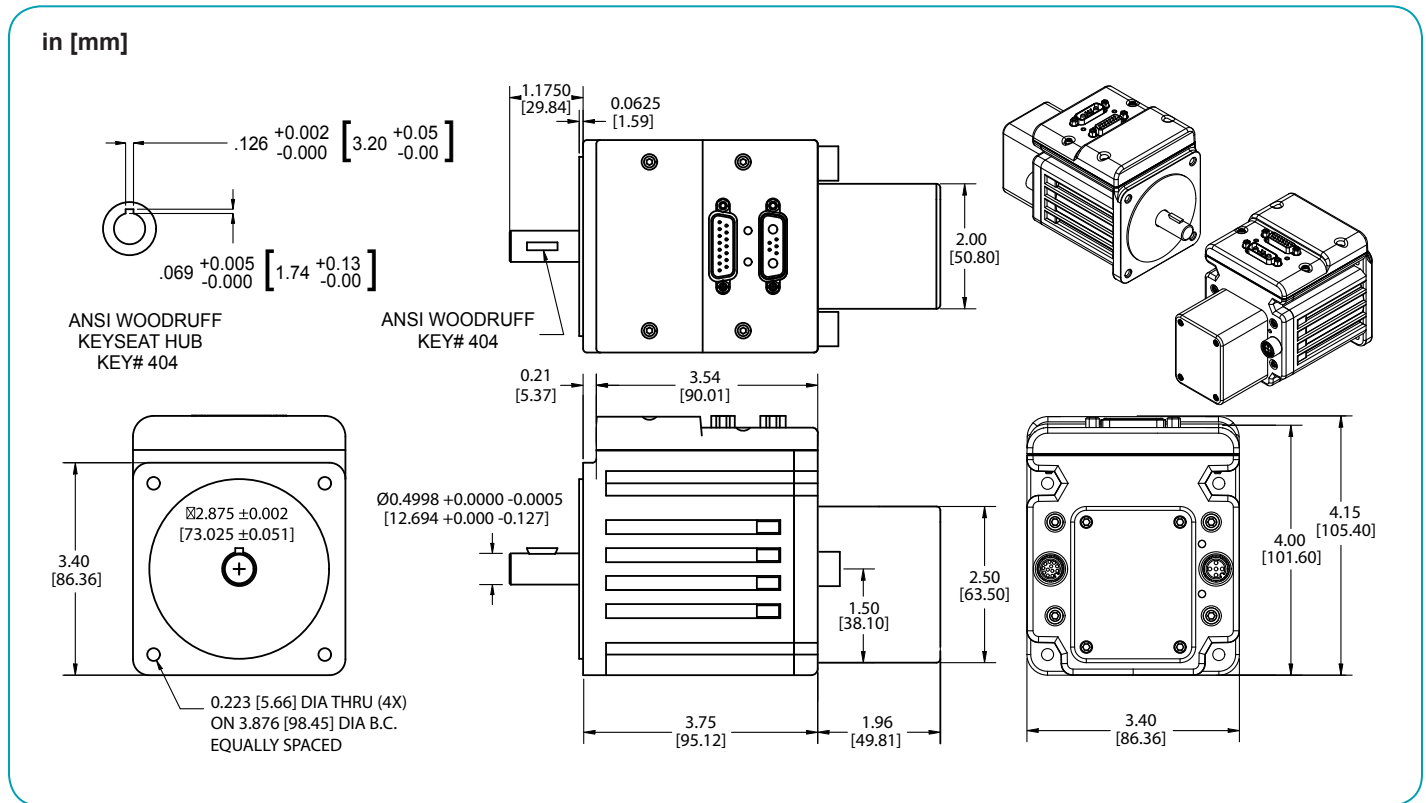

Animatics SmartMotor™ SM34165D-AD1

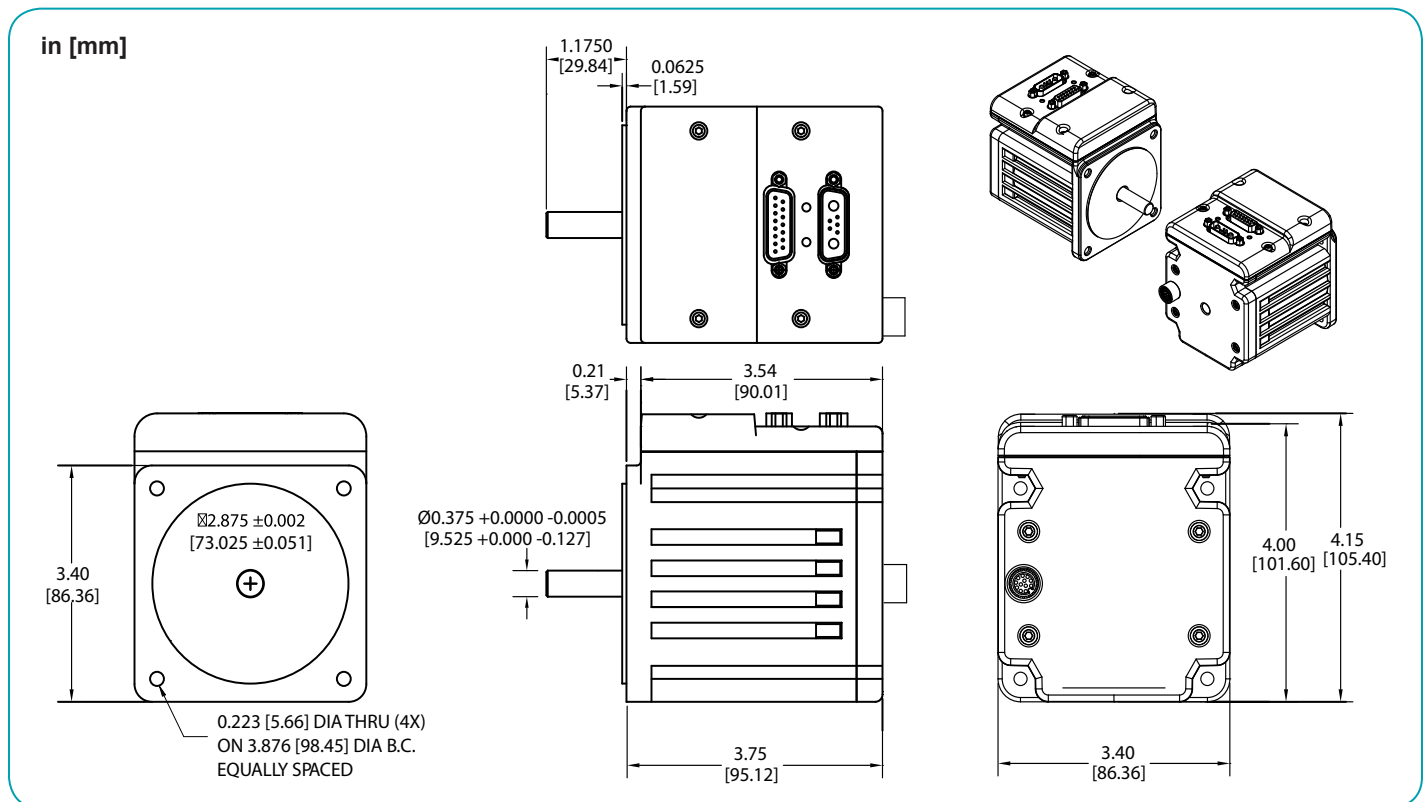

Animatics SmartMotor™ SM34165D-C

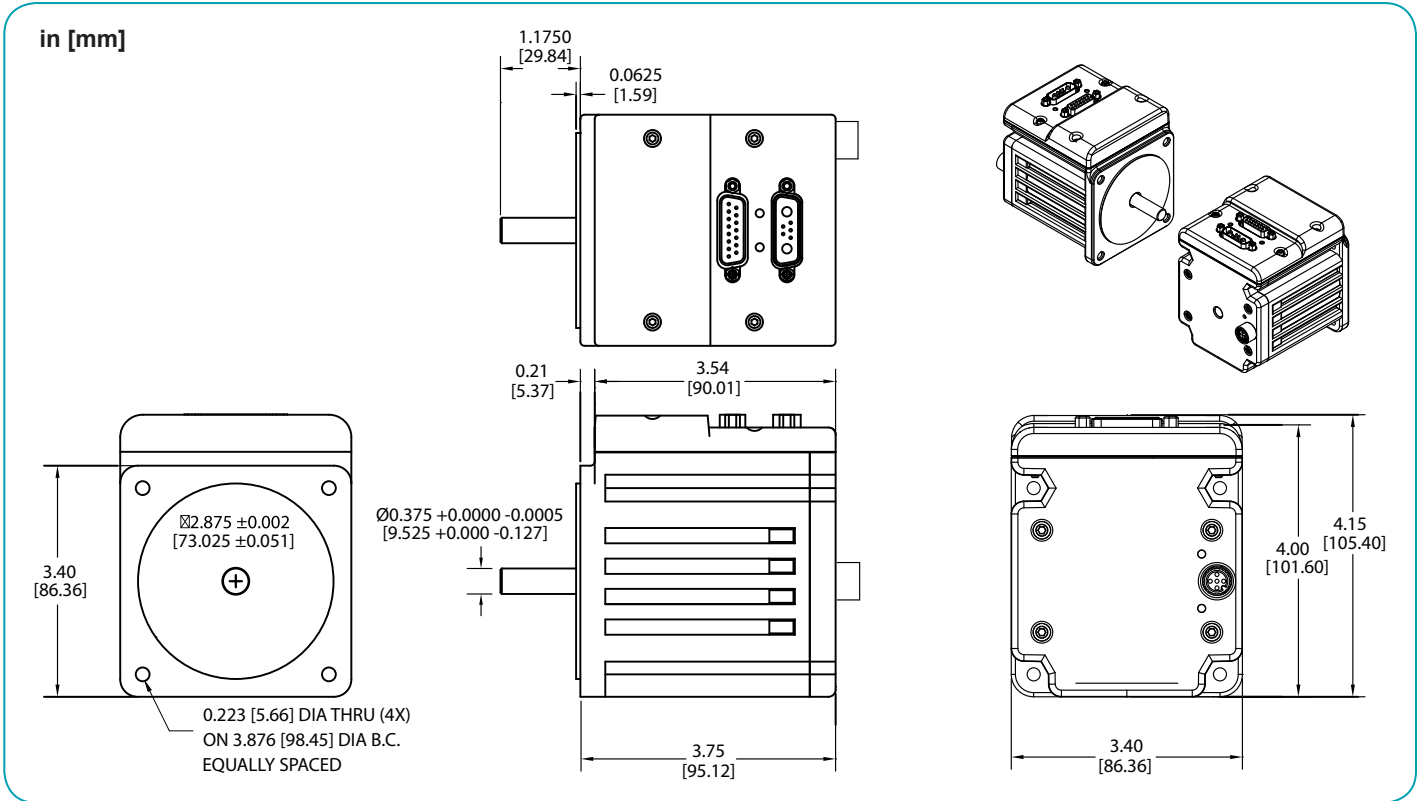

Animatics SmartMotor™ SM34165D-C-AD1

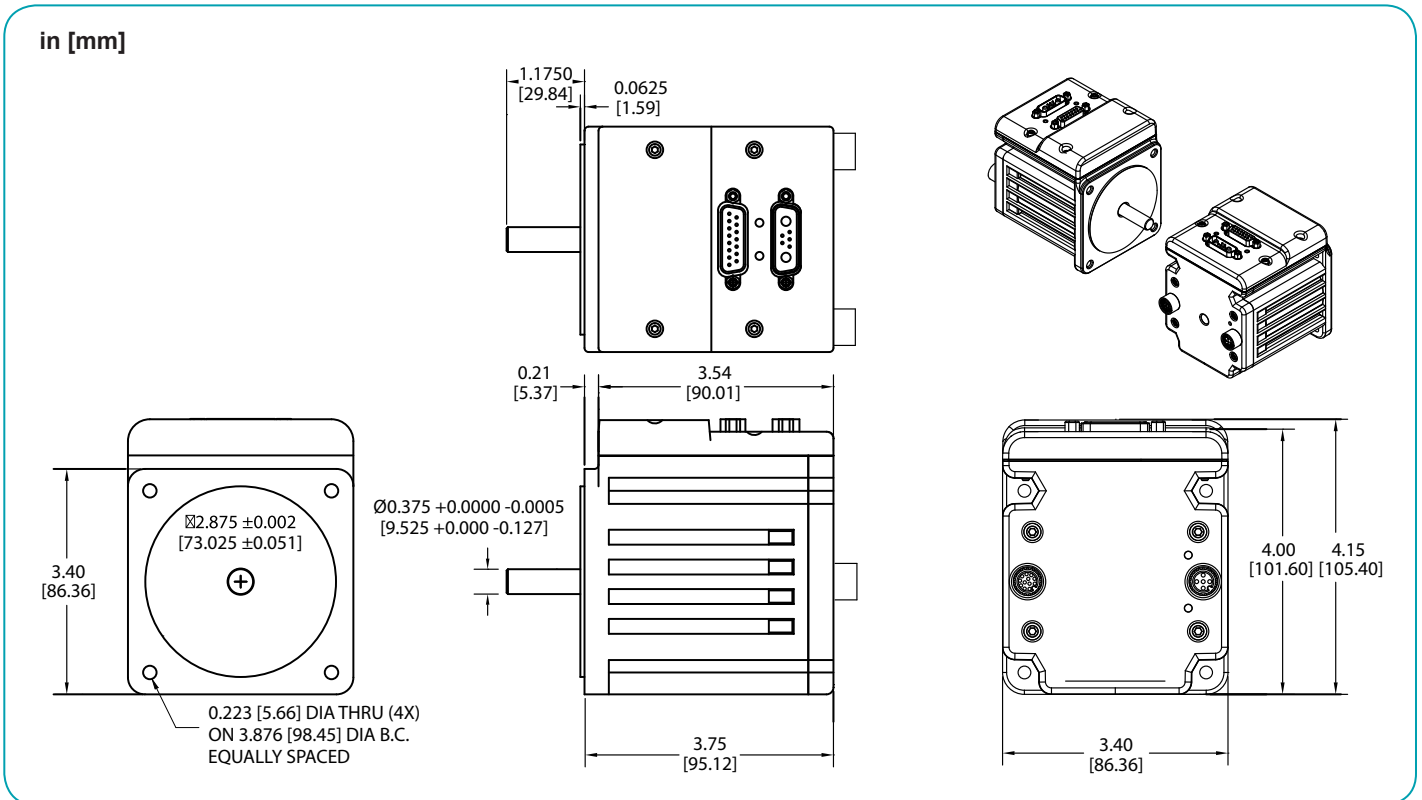

Animatics SmartMotor™ SM34165D-BRK

in [mm]

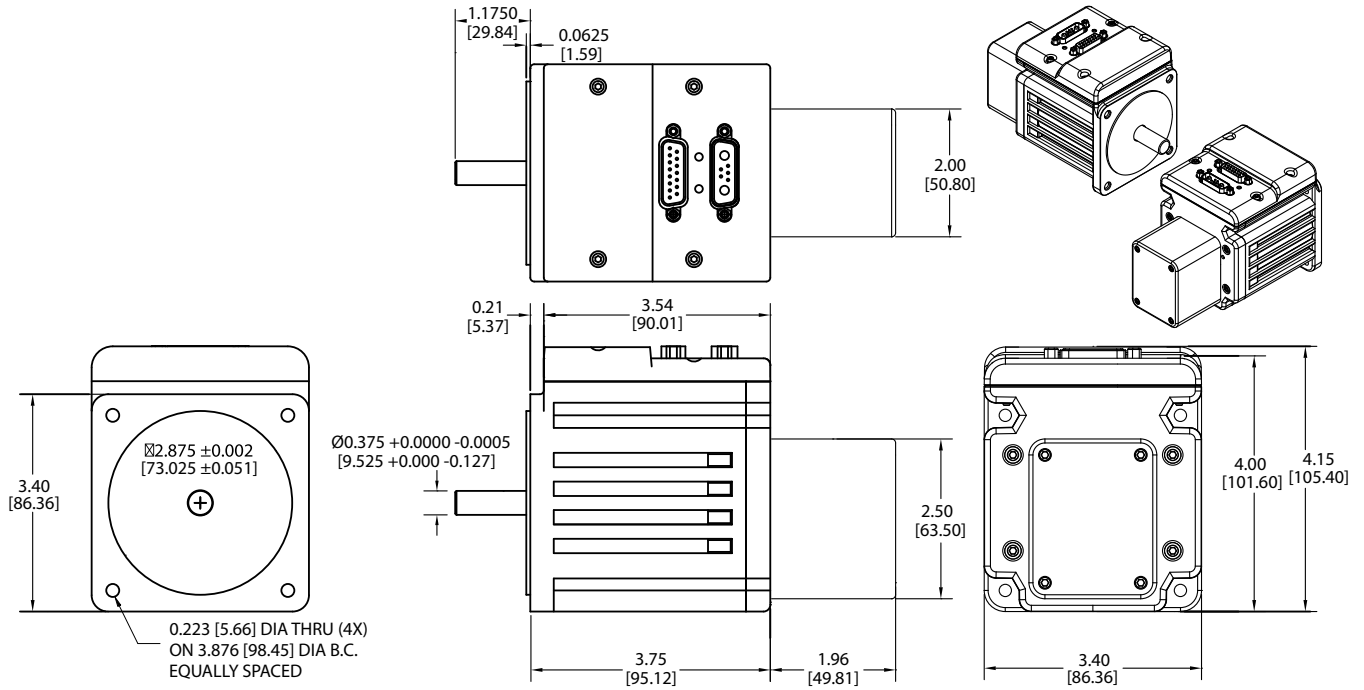

Animatics SmartMotor™ SM34165D-BRK-C-AD1

in [mm]

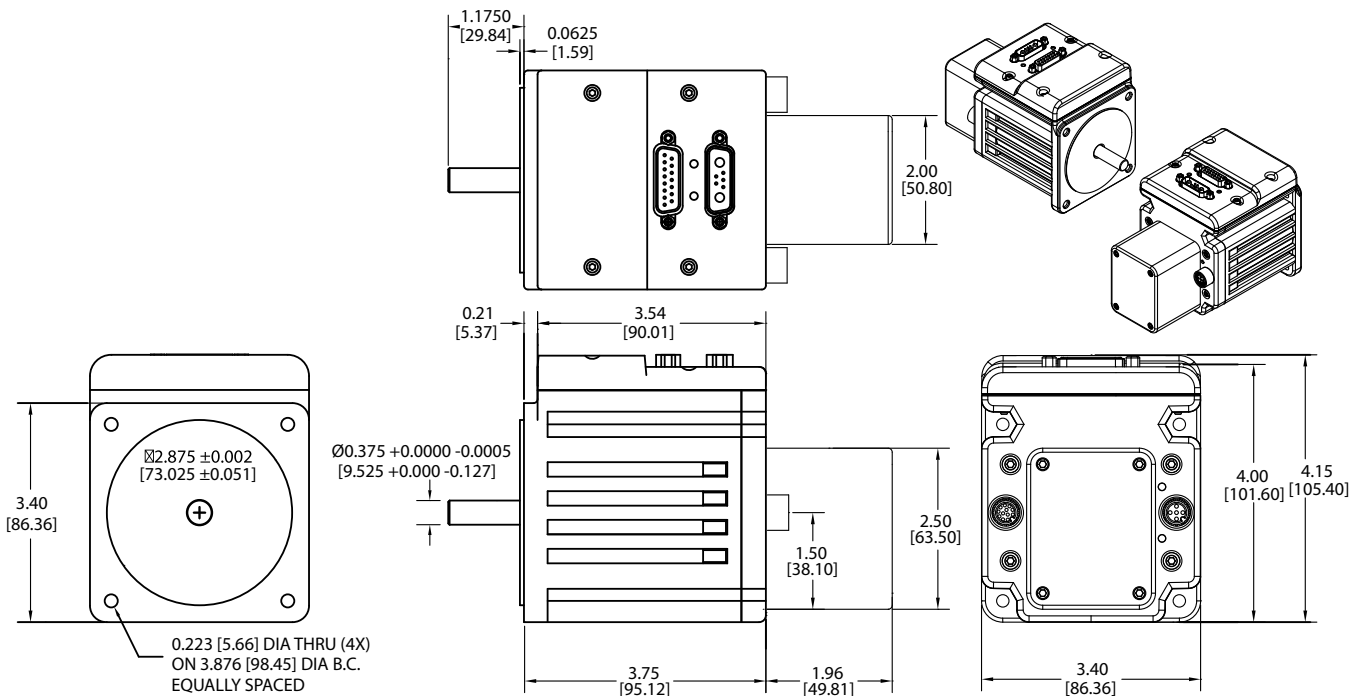

Animatics SmartMotor™ SM34165D-BRK-C

in [mm]

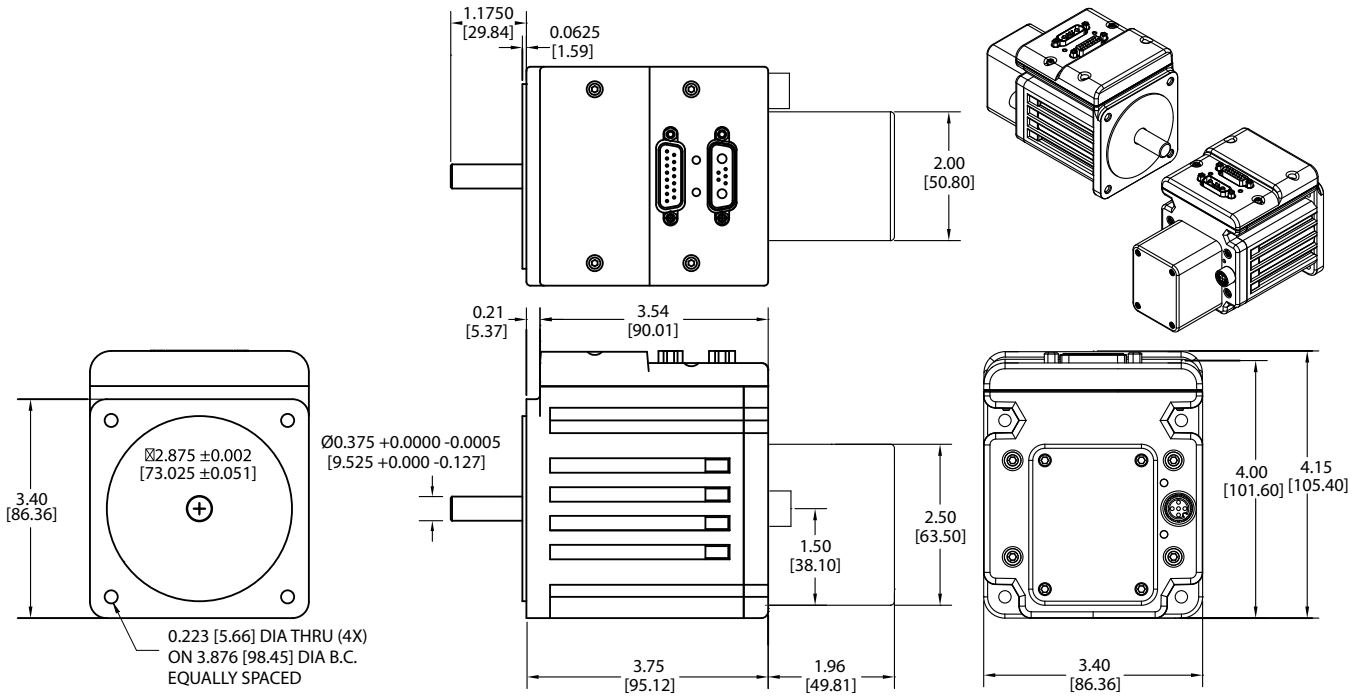

Animatics SmartMotor™ SM34165D-BRK-AD1

in [mm]

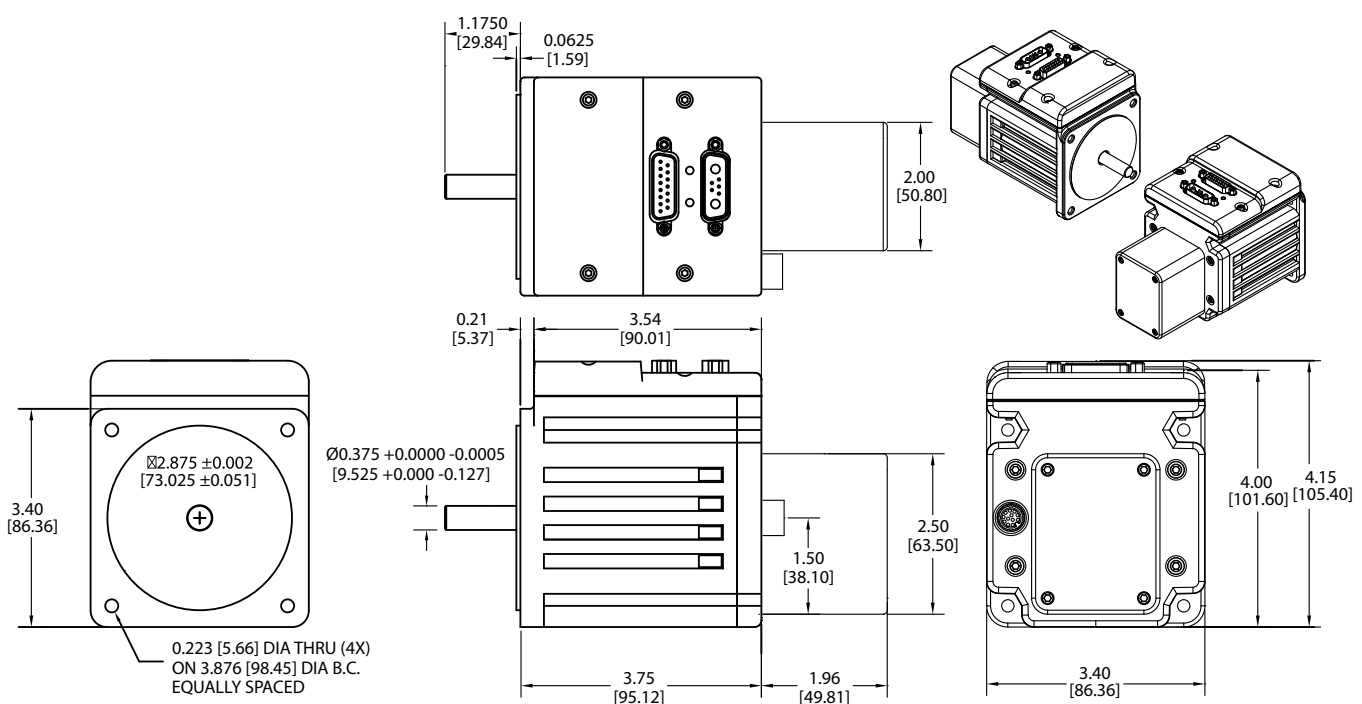

Animatics SmartMotor™ SM34x05D-AD1

in [mm]

PART NUMBER	LENGTH	
	in	mm
5M34105D	3.49	88.6
5M34205D	4.14	105.1
5M34305D	4.79	121.6
5M34405D	5.44	138.1
5M34505D	6.09	154.6

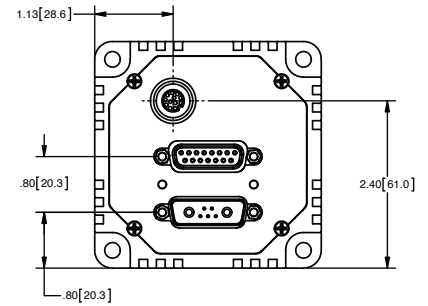
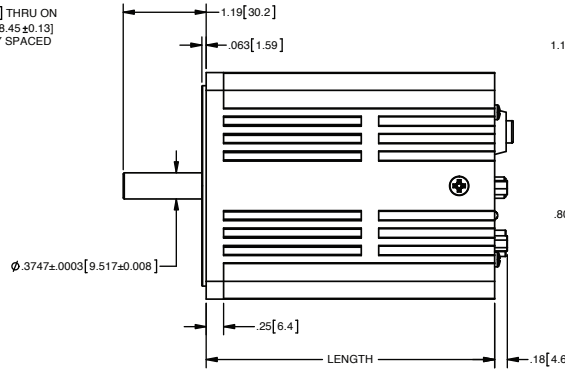
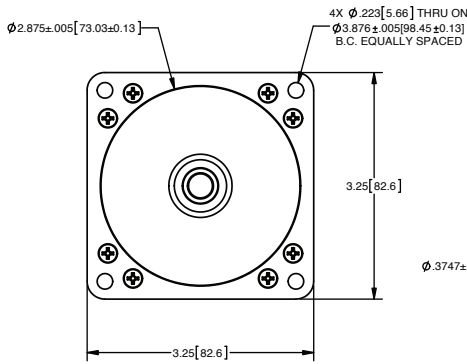
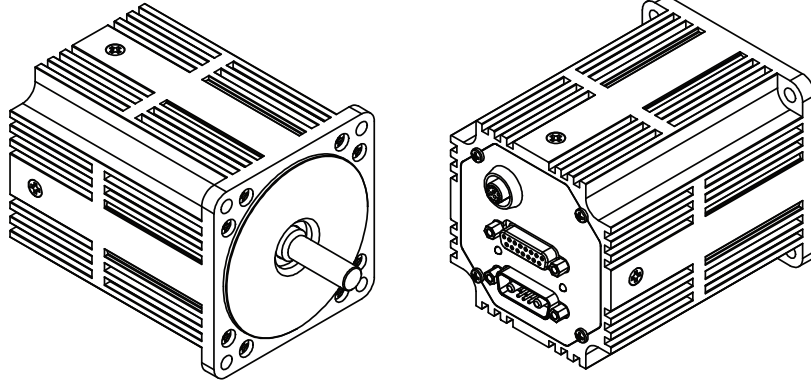

Animatics SmartMotor™ SM34x05D-C

in [mm]

PART NUMBER	LENGTH	
	in	mm
5M34105D	3.49	88.6
5M34205D	4.14	105.1
5M34305D	4.79	121.6
5M34405D	5.44	138.1
5M34505D	6.09	154.6

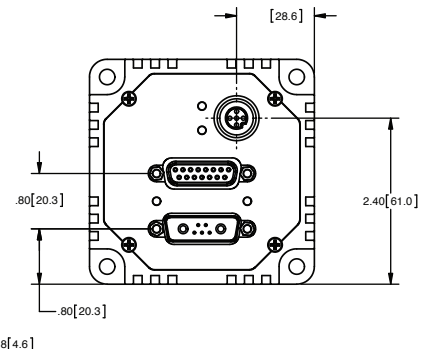
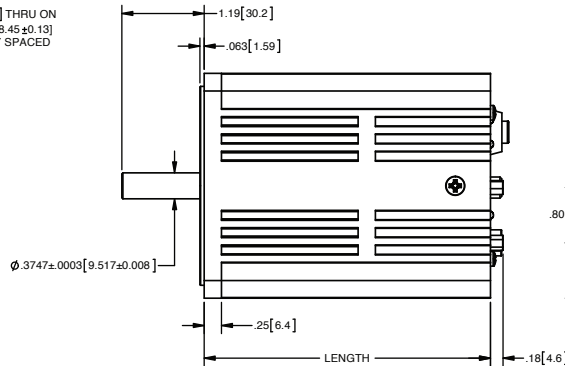
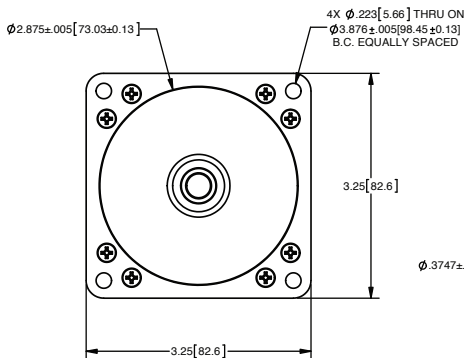
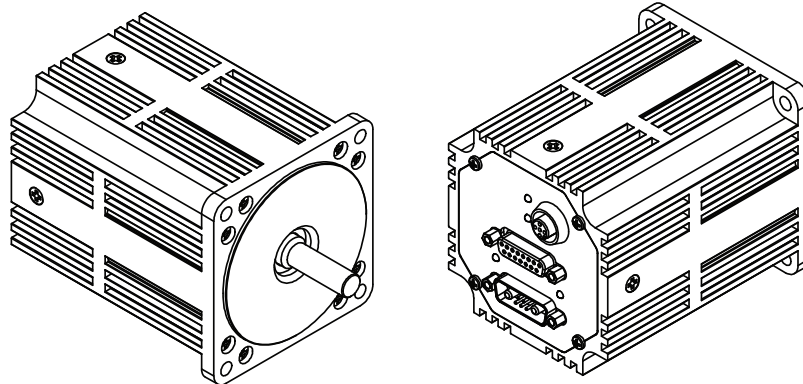

Animatics SmartMotor™ SM34x05D-C-AD1

in [mm]

PART NUMBER	LENGTH	
	in	mm
5M3410SD	3.49	88.6
5M3420SD	4.14	105.1
5M3430SD	4.79	121.6
5M3440SD	5.44	138.1
5M3450SD	6.09	154.6

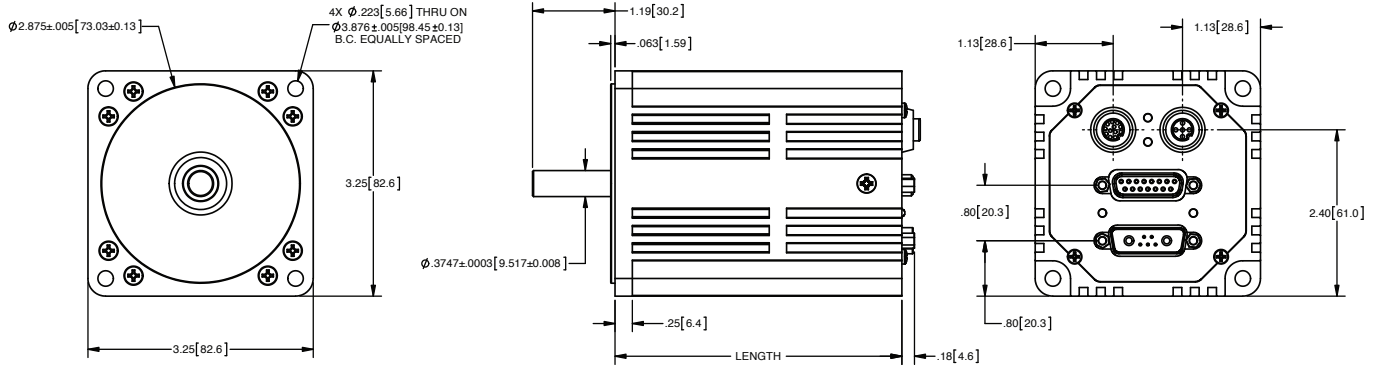
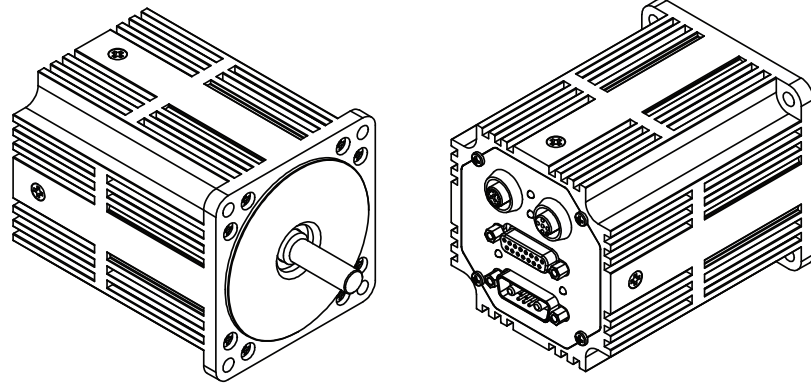

Animatics SmartMotor™ SM34x05D-BRK

in [mm]

PART NUMBER	LENGTH	
	in	mm
5M3410SD-BRK	5.44	138.1
5M3420SD-BRK	6.09	154.6
5M3430SD-BRK	6.74	171.1
5M3440SD-BRK	7.39	187.7
5M3450SD-BRK	8.04	204.2

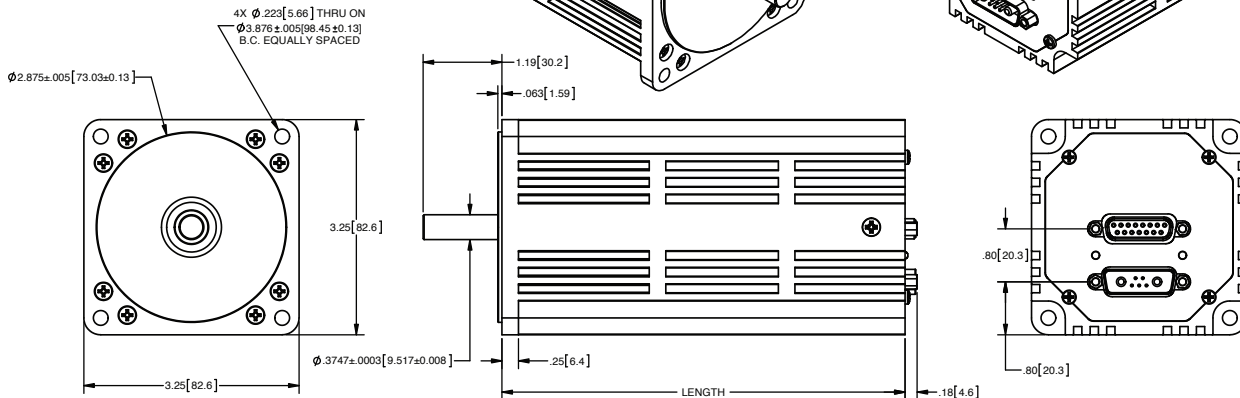
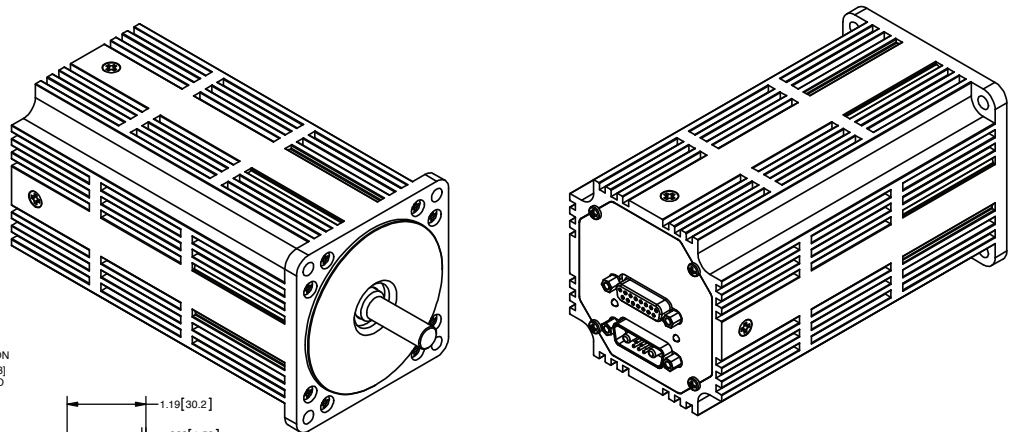

Animatics SmartMotor™ SM34x05D-BRK-AD1

in [mm]

PART NUMBER	LENGTH	
	in	mm
5M34105D-BRK	5.44	138.1
5M34205D-BRK	6.09	154.6
5M34305D-BRK	6.74	171.1
5M34405D-BRK	7.39	187.7
5M34505D-BRK	8.04	204.2

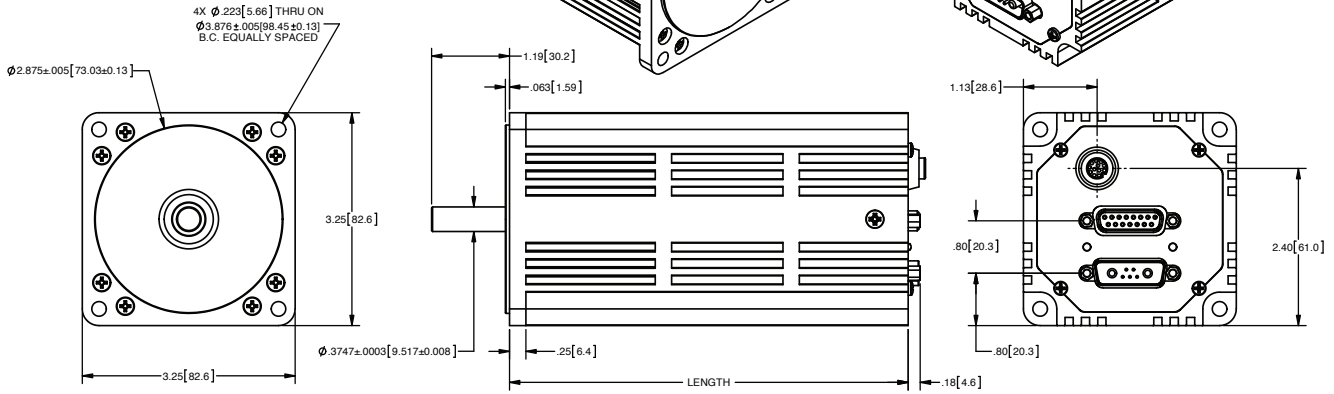

Animatics SmartMotor™ SM34x05D-BRK-C

in [mm]

PART NUMBER	LENGTH	
	in	mm
5M34105D-BRK	5.44	138.1
5M34205D-BRK	6.09	154.6
5M34305D-BRK	6.74	171.1
5M34405D-BRK	7.39	187.7
5M34505D-BRK	8.04	204.2

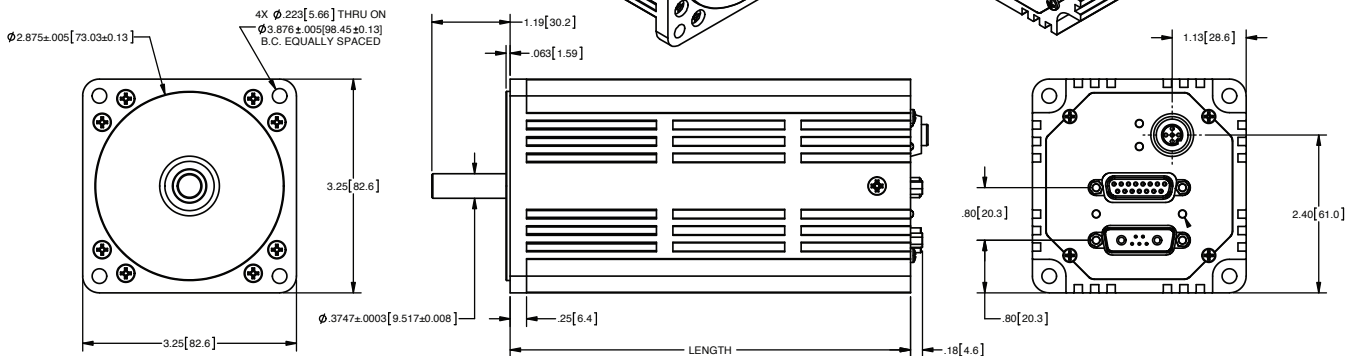

Animatics SmartMotor™ SM34x05D-BRK-C-AD1

in [mm]

PART NUMBER	LENGTH	
	in	mm
SM34105D-BRK	5.44	138.1
SM34205D-BRK	6.09	154.6
SM34305D-BRK	6.74	171.1
SM34405D-BRK	7.39	187.7
SM34505D-BRK	8.04	204.2

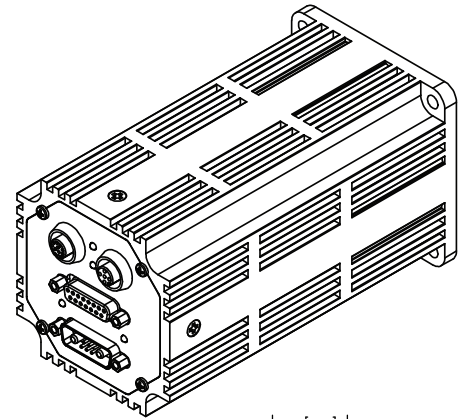
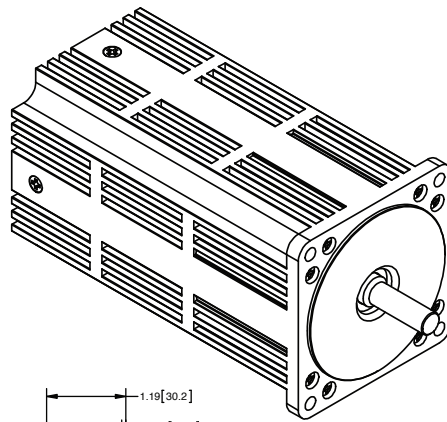

4X $\phi 2.23 [5.66]$ THRU ON
 $\phi 3.876 \pm .005 [98.45 \pm 0.13]$
 B.C. EQUALLY SPACED

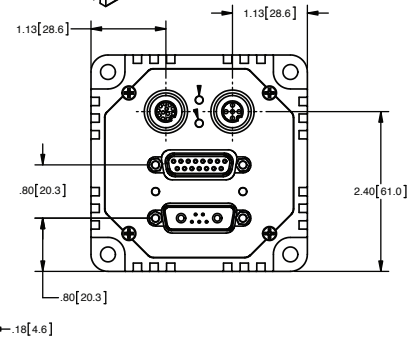
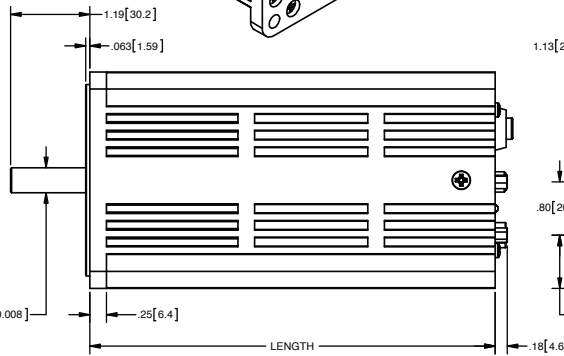
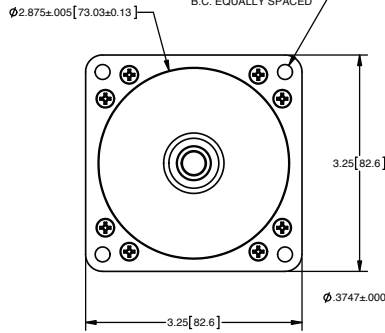

Download SmartMotor™ Specifications and More at www.animatics.com/support

On the Animatics website, we strive to provide all of the information you need to fully utilize all benefits of our products. From How-to Videos, interactive FAQs and Forums, and our Knowledge Base of white papers, articles and more, the Animatics website holds a myriad of knowledge free to you.

The Download Center in the Support section gives you access to SmartMotor drawings and specifications, actuator drawings and specifications, software downloads, SMI sample programs, and other product information. Download any product files in the following file formats: AutoCAD, SolidWorks, IGES, PDF CAD drawings and PDF specification sheets.

If you need a file you can't find on our website, feel free to contact support@animatics.com and we will find what you need.

Download Center

SmartMotor™ Drawings/Spec ▶
 Actuators Drawings/Spec ▶
 Software ▶
 SMI Sample Programs ▶
 Product Information ▶

Contact Tech Support

888.356.0357

Tech Support Form

Request a FREE catalog

The SmartMotor™ Companion

File Format	AutoCAD	SolidWorks	IGES	CAD Drawing	Spec
1700 Series					
SM17205D	SM17205D	SM17205D	SM17205D	SM17205D w/ 24V I/O w/ Brake w/ Brake & 24V I/O w/ Brake & CANopen & 24V I/O w/ CANopen w/ CANopen & 24V I/O	SM17205D
2300 Series					
SM23165D & SM23165DT	SM23165D/DT - w/ 24V I/O - w/ Brake - w/ CANopen - w/ CANopen & 24V I/O - w/ PROFIBUS	SM23165D/DT - w/ 24V I/O - w/ Brake - w/ CANopen - w/ CANopen & 24V I/O - w/ PROFIBUS	SM23165D/DT - w/ 24V I/O - w/ Brake - w/ CANopen - w/ CANopen & 24V I/O - w/ PROFIBUS	SM23165D/DT - w/ 24V I/O - w/ Brake - w/ CANopen - w/ CANopen & 24V I/O - w/ PROFIBUS	SM23165D SM23165DT
SM23375D & SM23375DT	SM23375D/DT - w/ 24V I/O - w/ Brake - w/ Brake & 24V I/O - w/ Brake & CANopen & 24V I/O - w/ CANopen - w/ CANopen & 24V I/O	SM23375D/DT - w/ 24V I/O - w/ Brake - w/ Brake & 24V I/O - w/ Brake & CANopen & 24V I/O - w/ CANopen - w/ CANopen & 24V I/O	SM23375D/DT - w/ 24V I/O - w/ Brake - w/ Brake & 24V I/O - w/ Brake & CANopen & 24V I/O - w/ CANopen - w/ CANopen & 24V I/O	SM23375D/DT - w/ 24V I/O - w/ Brake - w/ Brake & 24V I/O - w/ Brake & CANopen & 24V I/O - w/ CANopen - w/ CANopen & 24V I/O	SM23375D SM23375DT
SM23105D				SM23105D - w/ 24V I/O - w/ Brake - w/ Brake & 24V I/O - w/ Brake & CANopen & 24V I/O	

Table Top Robot (TTR)

OVERVIEW
MOTOR SPECIFICATIONS
LINEAR SYSTEMS
CONNECTIVITY
PERIPHERALS
IP 65 MODELS & CONNECTIVITY
POWER SUPPLIES & SHUNTS
GEAR HEADS
SOFTWARE
APPENDIX

TTR1 - **200** - **150** - **050B** - **C** - **10**

① ② ③ ④ ⑤ ⑥

① Series	② X stroke (mm)	③ Y stroke (mm)	④ Z stroke (mm)	⑤ Fieldbus	⑥ 24V I/O
TTR	N 200 400 600	150 350 550	N - None 50 150 250 B - Brake (Optional)	C (CANopen) D (DeviceNet)	10 - 10 Points 20 - 20 Points 30 - 30 Points

Table Top Robot (TTR)

Animatics Table Top Robots consist of an X Y (optional Z) ball screw driven Cartesian system.

Each System has 2 (or 3) SmartMotors pre-wired through a RS-232 serial daisy chain (with Combitronic™ optional). Designed as a pre-configured system of components, the TTR is ready to be controlled either via Host PC, PLC, HMI, or all stand alone with user defined downloaded programs.

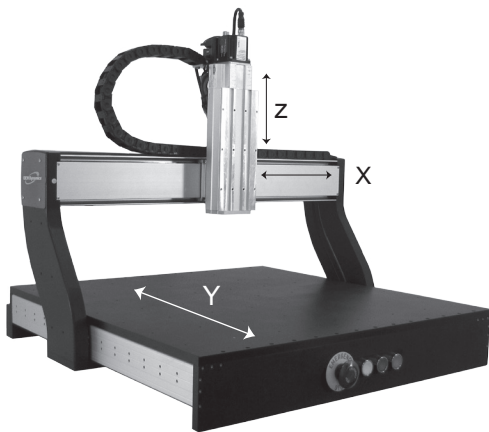

Features:

- Work area up to 600mmx550mmx250mm
- 120-240VAC 50./60hz Input
- E-Stop Drive Power
- Maintained control power
- 2.5mm/rev X and Y axis, 1600 counts/mm resolution
- 5mm/rev Z axis, 800 counts/mm resolution
- 275mm/sec X or Y, 550mm/sec Z
- Up to 45Kg load on Z Axis
- Optional up to 40 channels of Universal 24V I/O
- Optional Combitronic with CANopen or DeviceNet protocol

Application Videos

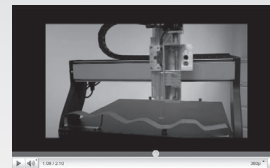

TTR Laser Distance Scanning

http://bit.ly/ttr_c



Linear Interpolation TTR & COMBITRONIC™

http://bit.ly/ttr_b



ANIMATICS®

on

You Tube

*Built with all  construction

User Interface

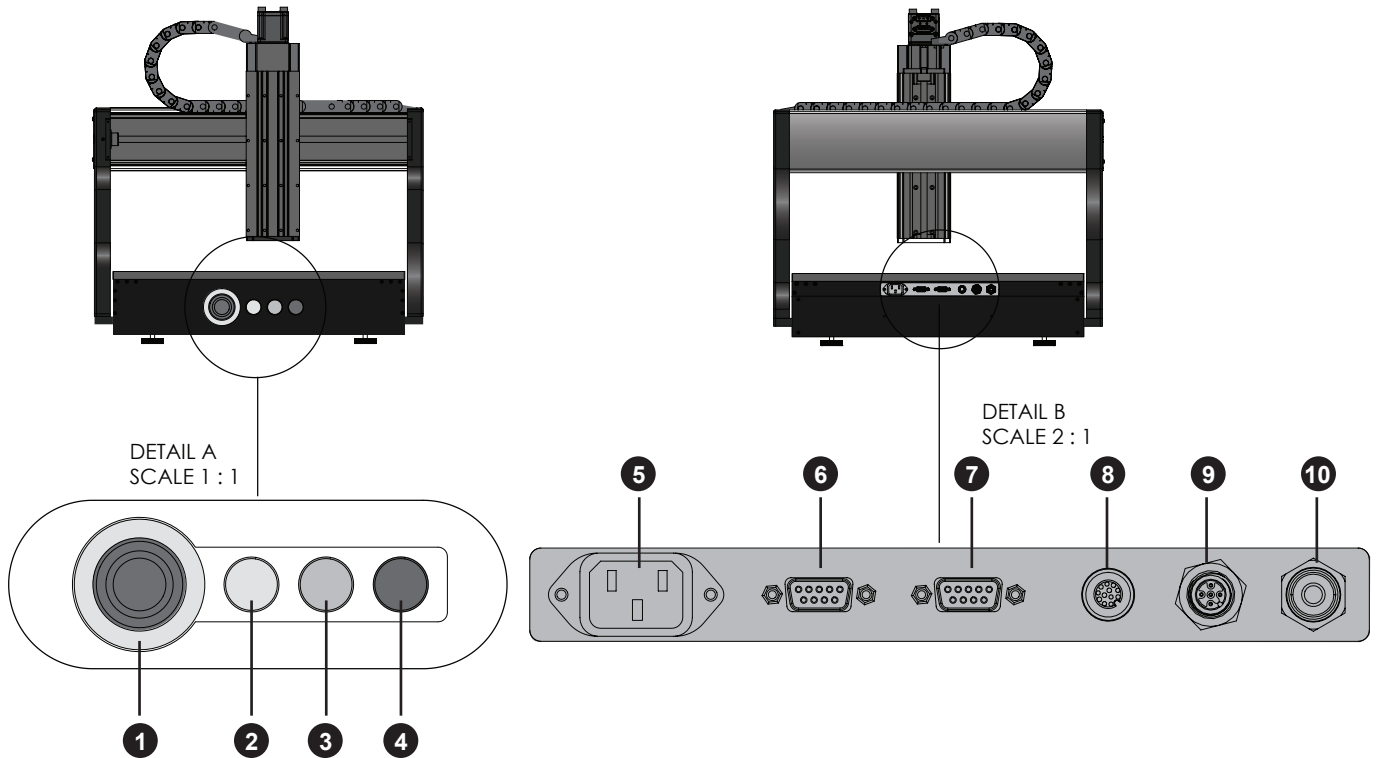

- 1** Emergency Stop (Red button) **2** Configurable (Yellow button) **3** Configurable (Green button)
- 4** Configurable (Blue button) **5** AC Power Input (88~264 VAC, 47~63 HZ) **6** RS232 Connector
- 7** D-sub 9pin Connector for end effector **8** 24 V I/O -10 total **9** CANopen / DeviceNet Connector
- 10** Air Supply Connector

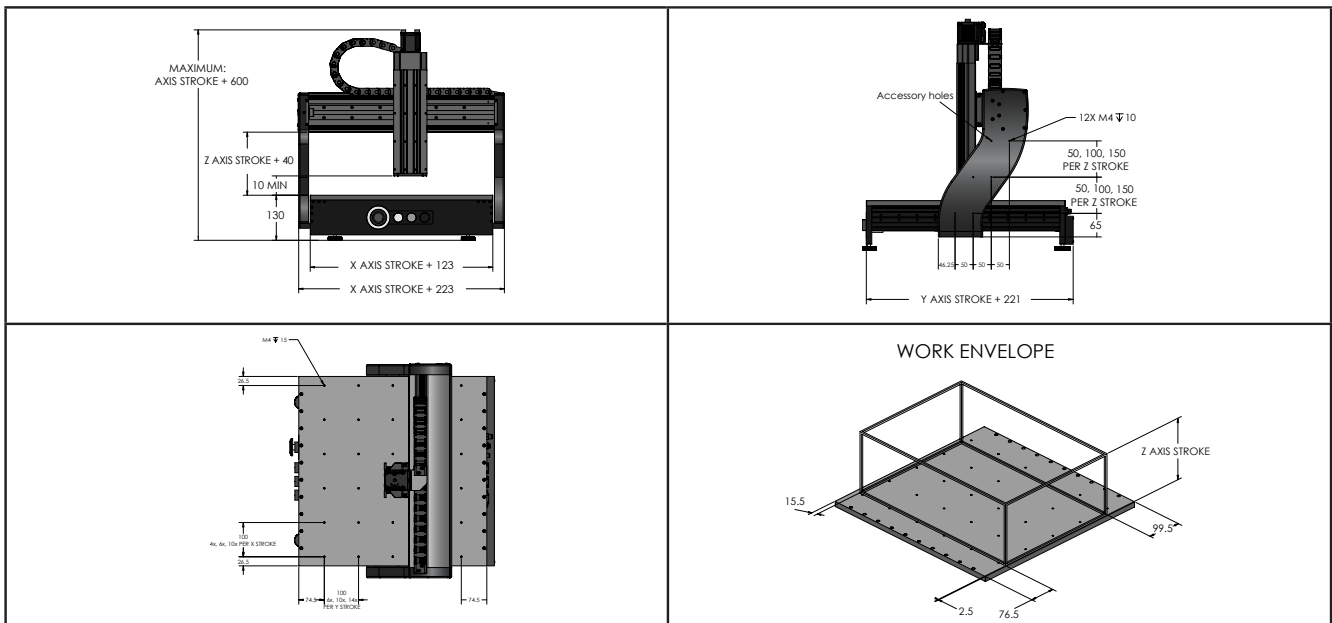

Specifications for 3-axis Systems

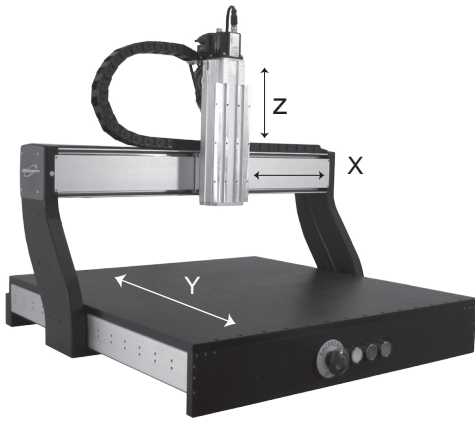

Axis Stroke Length (mm)			Max Speed (mm/s)*	Load Capability (kg)	Repeatability (mm)	Model Number
X	Y	Z				
200	150	50	400	45	0.016	TTR1-200-150-050-x-xx
200	350	50	400	45	0.016	TTR1-200-350-050-x-xx
200	550	50	400	45	0.016	TTR1-200-550-050-x-xx
200	150	150	400	45	0.016	TTR1-200-150-150-x-xx
200	350	150	400	45	0.016	TTR1-200-350-150-x-xx
200	550	150	400	45	0.016	TTR1-200-550-150-x-xx
200	150	250	400	45	0.016	TTR1-200-150-250-x-xx
200	350	250	400	45	0.016	TTR1-200-350-250-x-xx
200	550	250	400	45	0.016	TTR1-200-550-250-x-xx
400	150	50	400	45	0.016	TTR1-400-150-050-x-xx
400	350	50	400	45	0.016	TTR1-400-350-050-x-xx
400	550	50	400	45	0.016	TTR1-400-550-050-x-xx
400	150	150	400	45	0.016	TTR1-400-150-150-x-xx
400	350	150	400	45	0.016	TTR1-400-350-150-x-xx
400	550	150	400	45	0.016	TTR1-400-550-150-x-xx
400	150	250	400	45	0.016	TTR1-400-150-250-x-xx
400	350	250	400	45	0.016	TTR1-400-350-250-x-xx
400	550	250	400	45	0.016	TTR1-400-550-250-x-xx
600	150	50	400	45	0.016	TTR1-600-150-050-x-xx
600	350	50	400	45	0.016	TTR1-600-350-050-x-xx
600	550	50	400	45	0.016	TTR1-600-550-050-x-xx
600	150	150	400	45	0.016	TTR1-600-150-150-x-xx
600	350	150	400	45	0.016	TTR1-600-350-150-x-xx
600	550	150	400	45	0.016	TTR1-600-550-150-x-xx
600	150	250	400	45	0.016	TTR1-600-150-250-x-xx
600	350	250	400	45	0.016	TTR1-600-350-250-x-xx
600	550	250	400	45	0.016	TTR1-600-550-250-x-xx

* Maximum speed measured at no load

Specifications for 2-axis Systems

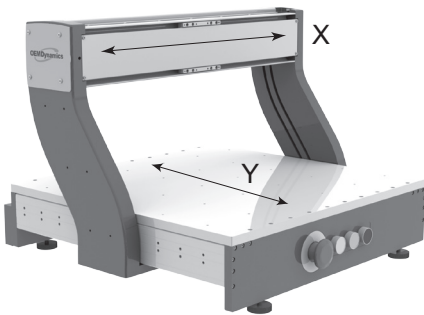

X-Y

Axis Stroke Length (mm)			Max Speed (mm/s)	Load Capability (kg)	Repeatability (mm)	Model Number
X	Y	Z				
200	150	-	400	45	0.016	TTR1-200-150-N-x-xx
200	350	-	400	45	0.016	TTR1-200-350-N-x-xx
200	550	-	400	45	0.016	TTR1-200-550-N-x-xx
400	150	-	400	45	0.016	TTR1-400-150-N-x-xx
400	350	-	400	45	0.016	TTR1-400-350-N-x-xx
400	550	-	400	45	0.016	TTR1-400-550-N-x-xx
600	150	-	400	45	0.016	TTR1-600-150-N-x-xx
600	350	-	400	45	0.016	TTR1-600-350-N-x-xx
600	550	-	400	45	0.016	TTR1-600-550-N-x-xx

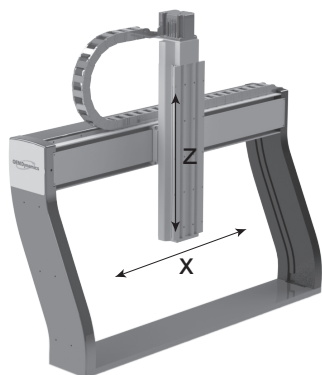

X-Z

Axis Stroke Length (mm)			Max Speed (mm/s)	Load Capability (kg)	Repeatability (mm)	Model Number
X	Y	Z				
200	-	50	400	45	0.016	TTR1-200-N-50-x-xx
200	-	50	400	45	0.016	TTR1-200-N-50-x-xx
200	-	50	400	45	0.016	TTR1-200-N-50-x-xx
400	-	150	400	45	0.016	TTR1-400-N-150-x-xx
400	-	150	400	45	0.016	TTR1-400-N-150-x-xx
400	-	150	400	45	0.016	TTR1-400-N-150-x-xx
600	-	250	400	45	0.016	TTR1-600-N-250-x-xx
600	-	250	400	45	0.016	TTR1-600-N-250-x-xx
600	-	250	400	45	0.016	TTR1-600-N-250-x-xx

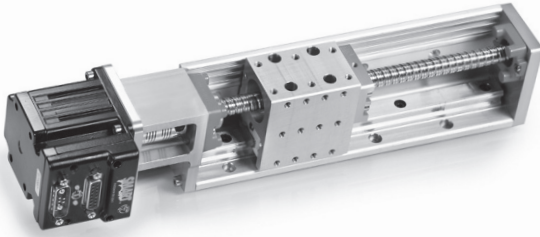

All OEM Dynamics™ Linear Integrated Systems are covered by Animatics patent #5,912,541 and other patents are in progress worldwide

OEM Dynamics is the Systems Integration division of Animatics Corporation. Its purpose is to couple proven Integrated Servo Controls with innovative designs in Linear Actuators to provide System Components and sub-assemblies for high-end automation. With over 20 years of application designs operating on production floors internationally, we offer high performance, low cost, reliable components and sub systems for industries including but not limited to:

- Consumable Product Packaging Machines
- Semiconductor Wafer and Chip Processing
- Biomedical Process and Control equipment
- Automotive Component Assembly and Testing
- CNC Wood and Metal Cutting Systems
- Aviation Testing and Control
- Nuclear Fuel Rod Handling Systems

OEM Dynamics is dedicated to deliver Component Level Products and Sub-System Assemblies with high performance and reliability at the lowest possible prices. Our coupled sub-systems allow you to just drop us in and go!

“Harmonic Linear Belt Drive Systems eliminate costly gear heads and brakes”

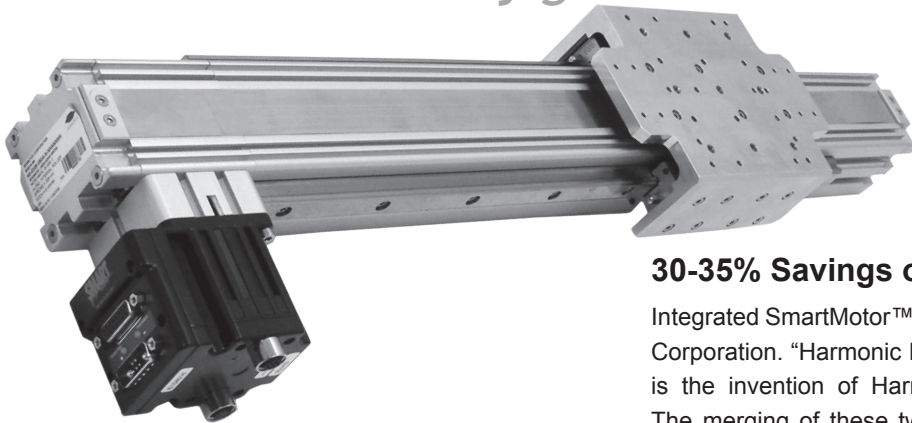

Low Cost Breakthrough!

Lowering cost without sacrificing quality, accuracy or system integrity is the number one topic and goal on the minds of the board of directors and management of every major company in the world. Today, the goal is achievable without resorting solely on the old fashioned cost cutting methods of reducing US. and European employees in favor of offshore suppliers. OEM Dynamics now has a fully integrated linear motion system that reduces costs by reducing system parts and components as well as engineering and assembly time - through innovation.

30-35% Savings on System Costs

Integrated SmartMotor™ technology is the invention of Animatics Corporation. “Harmonic Linear Drive™” belt actuator technology is the invention of Harmonic Linear Drives, Ltd. in England. The merging of these two technologies has shown to save as much as 35% when compared to the equivalent, conventional components. For any given axis of motion, this system design approach provides linear bearing load support, harmonic zero-backlash gear reduction, a true closed-loop brushless motor and digital drive, and a 32-bit programmable controller. The Intrinsic reduction provides a high resistance to back-driving, a benefit usually purchased in the form of a brake.

The SmartMotor eliminates a cabinet full of controls by building everything into the motor. The Harmonic Linear Drive™ eliminates a gear-head and brake by wrapping the belt around subtly different diameter pulleys in a way that produces inherent gear reduction using the Harmonic Principle. All told – this clever, compact combination uses fewer parts, increases reliability and markedly lowers the cost of your machine.

Understanding Part Numbers

Part Number Examples:

1. Overview

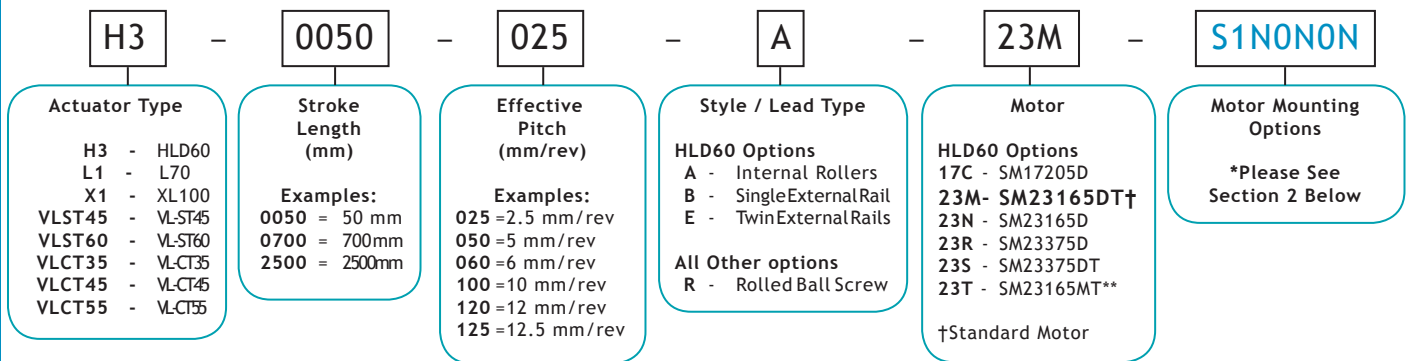

2. Motor Mounting Options (Last 7 or 8 Digits)

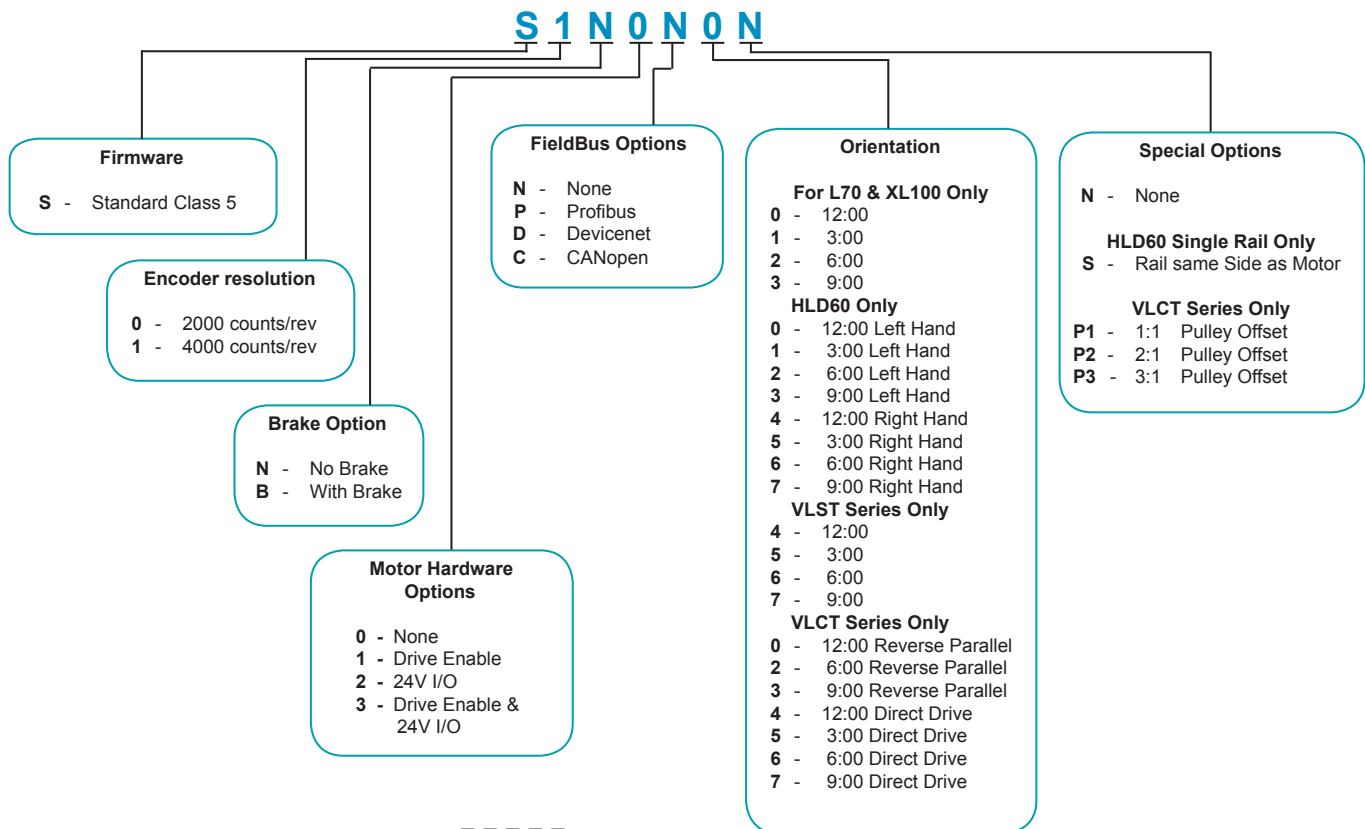

****Note:** Actuator not IP rated.

Note: Please note there are no "O's" in the part number, only zeros. Questions? Please see the website for Part Number Generator at www.oemdynamics.com or call 408.748.8721

Actuator Comparison Chart



		HLD60 with Internal Rollers				HLD60 with External Rail				HLD60 with Twin External Rails			
Type of Actuator		Harmonic Belt				Harmonic Belt				Harmonic Belt			
Standard Stroke Lengths	mm	100 – 600 mm in 50 mm steps				100 – 600 mm in 50 mm steps				100 – 600 mm in 50 mm steps			
		600 – 1000 mm in 100 mm steps				600 – 1000 mm in 100 mm steps				600 – 1000 mm in 100 mm steps			
		1000 – 3200 mm in 200 mm steps				1000 – 2800 mm in 200 mm steps				1000 – 2800 mm in 200 mm steps			
Unidirectional Repeatability	µm	<20											
Bi-directional Repeatability	µm	60 - 180											
Linear Accuracy	mm/mm	0.5 / 300				0.5 / 300				0.5 / 300			
Displacement/rev	mm/rev	2.5	5	10	12.5	2.5	5	10	12.5	2.5	5	10	12.5
Max linear speed ⁽¹⁾ (no load)	mm/sec	200	391	782	977	200	391	782	977	200	391	782	914
Continuous Thrust ⁽²⁾	N	450	420	185	135	450	420	185	135	450	400	160	105
Payload Mass	kg	45	42	18	13	45	42	18	13	45	40	16	10
Carriage Moments, Dynamic ⁽³⁾, (Static)													
Carriage Moments, M.a ⁽³⁾	Nm	1.0 (2.4)	0.80 (2.4)	0.6 (2.4)	0.55 (2.4)	19 (24)	15 (24)	12 (24)	11 (24)	180 (200)	144 (200)	114 (200)	106 (200)
Carriage Moments, M.b ⁽³⁾	Nm	3.2 (8)	2.5 (8)	2.0 (8)	1.9 (8)	72 (200)	57 (200)	45 (200)	42 (200)	144 (200)	113 (200)	89 (200)	84 (200)
Carriage Moments, M.c ⁽³⁾	Nm	3.2 (12)	2.5 (12)	2.0 (12)	1.9 (12)	72 (150)	57 (150)	45 (150)	42 (150)	144 (200)	113 (200)	89 (200)	84 (200)
Overall Length	mm	Stroke + 332				Stroke + 332				Stroke + 332			
Over-Travel	mm	25				25				25			
Unit Mass	kg	2.3 + 0.0031*(stroke, mm) + (motor mass, kg)				2.7 + 0.0044* (stroke, mm) + (motor mass, kg)				3.4 + 0.0057*(stroke, mm) + (motor mass, kg)			

Note: For part numbers please refer to our Website at www.oemdynamics.com

⁽¹⁾ Based on using SM2316DT @ 48V at no load. Please see pages 109-126 for details of thrust curves

⁽²⁾ Based on using SM2316DT @ 48V @ 3800 RPM. Please see pages 109-126 for details of thrust curves.

⁽³⁾ Based on a 15000 hr service life @ 75/150/300 & 375mm/s (1800 RPM) average speed at the given payload subject to routine lubrication.

OVERVIEW
MOTOR SPECIFICATIONS
LINEAR SYSTEMS
CONNECTIVITY
PERIPHERALS
CONNECTIVITY
IP 65 MODELS & CONNECTIVITY
SHUNTS
GEAR HEADS
SOFTWARE
APPENDIX

Actuator Comparison Chart



		L70		XL100		VL-ST				VL-CT		
Type of Ball Screw Actuator		Rodless Type		Rodless Type		Rodless Type				Rod Type		
Standard Stroke Lengths	mm	50 – 600 mm in 50 mm steps		50 – 600 mm in 50 mm steps		50 – 600 mm in 50 mm steps + 700mm				50 – 300 mm in 50 mm steps		
Unidirectional Repeatability	µm	3		3		20				20		
Bi-directional Repeatability	µm	16		16		40				40		
Ball Screw Lead Accuracy	mm/mm	0.1/300		0.1/300		0.21/300				0.21/300		
Displacement/rev	mm/rev	5	10	5	10	VL-ST45		VL-ST60		12		
						6	12	6	12			
Max linear speed ⁽⁴⁾	mm/sec	350 ⁽⁴⁾	910 ⁽⁴⁾	350 ⁽⁴⁾	910 ⁽⁴⁾	500 ⁽⁴⁾	1000 ⁽⁴⁾	500 ⁽⁴⁾	1000 ⁽⁴⁾	1000 ⁽⁴⁾		
Continuous Thrust ⁽⁵⁾	N	587	294	587	294	489	245	489	245	Pulley Reduction		
										1:1	2:1	3:1 ⁽⁶⁾
										262	524	786 ⁽⁶⁾
Payload Mass	kg	25	20	25	20	8	6.5	13	10	VL-CT35	VL-CT45	VL-CT55
										5.6	5.6	22
Carriage moments, Dynamic ⁽⁷⁾, (Static)												
Carriage Moments, M.a ⁽⁷⁾	Nm	5 (20)		25 (500)		4.47 (31)	3.44 (31)	11.47 (58)	9 (58)	0		
Carriage Moments, M.b ⁽⁷⁾	Nm	5 (20)		25 (500)		1.64 (12)	1.33 (12)	3.57 (25)	2.75 (25)	0		
Carriage Moments, M.c ⁽⁷⁾	Nm	5 (20)		25 (500)		1.64 (12)	1.33 (12)	3.57 (25)	2.75 (25)	0		
Overall Length	mm	Stroke + 182.5 + Motor		Stroke + 223.5 + Motor		See pages 16, 18, 20, 24, 26						
Over-Travel	mm	24.5		24		10				None		
Unit Mass	kg	1.29 + 0.00414*(stroke, mm) + (motor mass, kg)		2.657 + 0.0049*(stroke, mm) + (motor mass, kg)		See pages 16, 18, 20, 24, 26						

Note: For part numbers please refer to our Website at www.oemdynamics.com

⁽⁴⁾ Please see Ball Screw CRITICAL SPEED limitations on p.90 (L70) & p.92 (XL100), p.98 (VL-CT35), p.100(VL-CT45), p.102 (VL-CT55), p.94 (VL-ST45), p.96 (VL-ST60).

⁽⁵⁾ Based on using SM2316DT @ 48V @ 2000 RPM. Please see pages 109-126 for details of thrust curves.

⁽⁶⁾ Based on using the VL-CT55 with SM2316DT. Max thrust for the VL-CT35/45 is 565N.

⁽⁷⁾ Based on a 15000 hr service life @ 167mm/s & 333 mm/s (2000 RPM) average speed at the given payload for L70 and XL100 subject to routine lubrication.

⁽⁷⁾ Based on a 15000 hr service life @ 200 mm/s & 400mm/s (2000 RPM) average speed at the given payload for VL series subject to routine lubrication.



HLD60 with Internal Roller Specifications

Parameter	Value				Units
Configuration & Physical Parameters					
Motor	Animatics Size 23 Motors				-
Coupling	Flexible Jaw				-
Displacement/rev	2.5, 5, 10, 12.5				mm/rev
Position sensors	Optional Home & EOT limits				-
Stroke	100-600mm in 50mm steps 600-1000mm in 100mm steps 1000-3200mm in 200mm steps Custom lengths are available				mm
Overall length (L)	Stroke + 332				mm
Over-travel	25				mm
Unit mass	2.3 + 0.0031 x (stroke, mm) + (motor mass, kg)				kg
Performance					
Unidirectional repeatability	<20				µm
Bi-directional repeatability	60-180 (belt tension dependent)				µm
Accuracy *	0.5 per 300 stroke				mm/mm
Displacement/rev	2.5	5	10	12.5	mm/rev
Linear speed @ 4200RPM	175	350	700	875	mm/s
Payload Mass**	45	42	18	13	kg
Continuous Thrust (Fa)					
SM2315D @ 48V @ 4500RPM	115	40	-	-	N
SM2315DT @ 48V @ 3300RPM	450	245	100	70	N
SM23165D @ 48V @ 4500RPM	270	120	35	-	N
SM23165DT @ 48V @ 3800RPM	450	420	185	135	N
SM23375D @ 48V @ 4500RPM	175	70	10	-	N
SM23375DT @ 48V @ 3200 RPM	450	290	125	90	N
Load Rating, Dynamic ** (Static)					
Fb	56 (110)	44 (110)	35 (110)	33 (110)	N
Fc	56 (200)	44 (200)	35 (200)	33 (200)	N
Carriage moments, Dynamic ** (Static)					
M.a	1.0 (2.4)	0.8 (2.4)	0.6 (2.4)	0.55 (2.4)	Nm
M.b	3.2 (8)	2.5 (8)	2.0 (8)	1.9 (8)	Nm
M.c	3.2 (12)	2.5 (12)	2.0 (12)	1.9 (12)	Nm

*Consult factory if greater accuracy is required

**Based on a 15000HR service life

@ 75/150/300 & 375mm/s (1800 RPM) average speed at given payload
Subject to routine lubrication

All OEM Dynamics™ Linear Integrated Systems are covered by
Animatics patent #5,912,541 and other patents are in progress worldwide

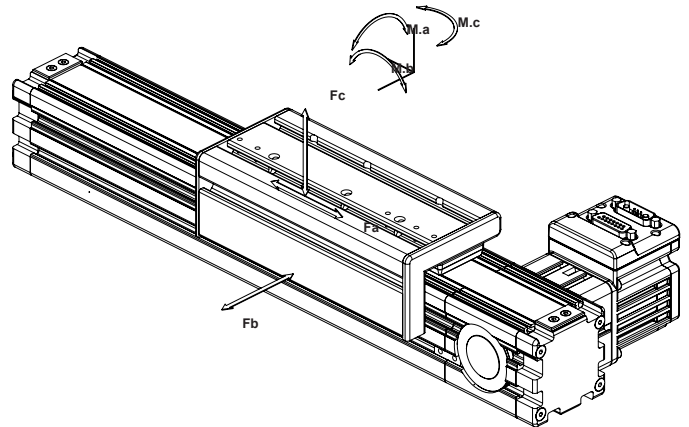

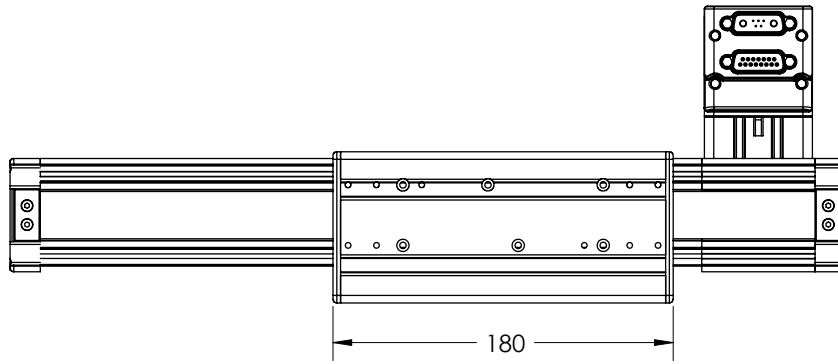

TOP VIEW

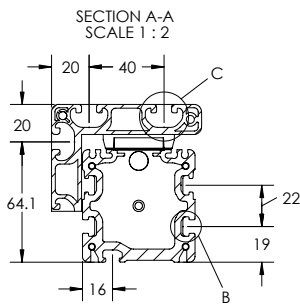

SIMPLE END VIEW

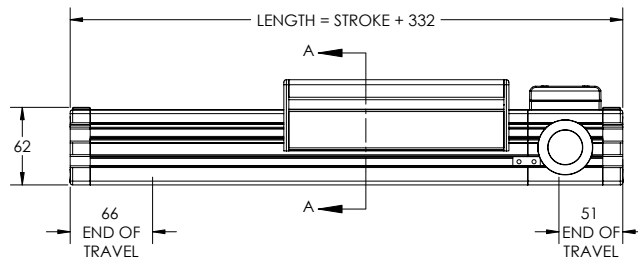

RIGHT SIDE VIEW

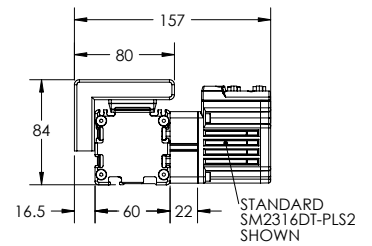

MOTOR END VIEW

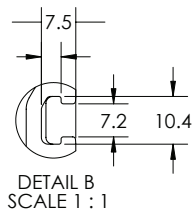

**DETAIL B
SCALE 1 : 1**

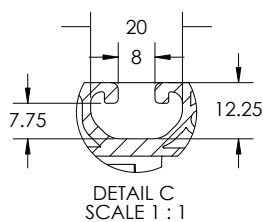

**DETAIL C
SCALE 1 : 1**

DETAILED END VIEW

Dimensions in millimeters

Note: For part numbers please refer to our Website at www.oemdynamics.com

Thrust Curve performance data in following section on pages 109-126.

HLD60 with External Rail Specifications

Parameter	Value				Units
Configuration & Physical Parameters					
Motor	Animatics Size 23 Motors				-
Coupling	Flexible Jaw				-
Displacement/rev	2.5, 5, 10, 12.5				mm/rev
Position sensors	Optional Home & EOT limits				-
Stroke	100-600mm in 50mm steps 600-1000mm in 100mm steps 1000-2800mm in 200mm steps Custom lengths are available				mm
Overall length (L)	Stroke + 332				mm
Over-travel	25				mm
Unit mass	2.73 + 0.00441 x (stroke, mm) + (motor mass, kg)				kg
Performance					
Unidirectional repeatability	<20				µm
Bi-directional repeatability	60-180 (belt tension dependent)				µm
Accuracy *	0.5 per 300 stroke				mm/mm
Displacement/rev	2.5	5	10	12.5	mm/rev
Linear speed @ 4200RPM	175	350	700	875	mm/s
Payload Mass**	45	42	18	13	kg
Continuous Thrust (Fa)					
SM2315D @ 48V @ 4500RPM	115	40	-	-	N
SM2315DT @ 48V @ 3300RPM	450	245	100	70	N
SM23165D @ 48V @ 4500RPM	270	120	35	-	N
SM23165DT @ 48V @ 3800RPM	450	420	185	135	N
SM23375D @ 48V @ 4500RPM	175	70	10	-	N
SM23375DT @ 48V @ 3200 RPM	450	290	125	90	N
Load Rating, Dynamic ** (Static)					
Fb	730 (1200)	580 (1200)	460 (1200)	430 (1200)	N
Fc	730 (1200)	580 (1200)	460 (1200)	430 (1200)	N
Carriage moments, Dynamic ** (Static)					
M.a	19 (24)	15 (24)	12 (24)	11 (24)	Nm
M.b	72 (200)	57 (200)	45 (200)	42 (200)	Nm
M.c	72 (150)	57 (150)	45 (150)	42 (150)	Nm

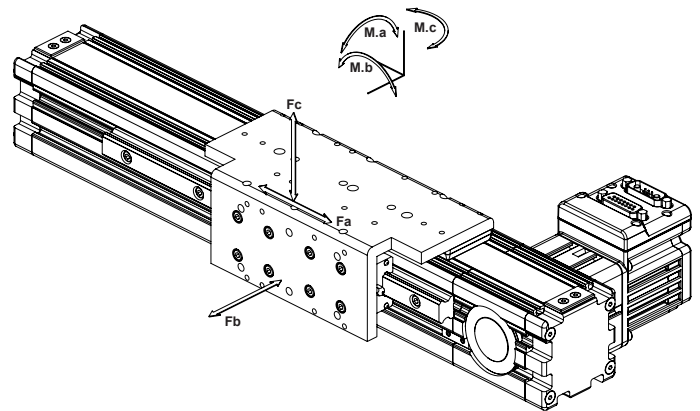

*Consult factory if greater accuracy is required

**Based on a 15000HR service life

@ 75/150/300 & 375mm/s (1800 RPM) average speed at given payload
Subject to routine lubrication

All OEM Dynamics™ Linear Integrated Systems are covered by Animatics patent #5,912,541 and other patents are in progress worldwide

OVERVIEW
MOTOR SPECIFICATIONS
LINEAR SYSTEMS
CONNECTIVITY
PERIPHERALS
IP 65 MODELS & CONNECTIVITY
POWER SUPPLIES & SHUNTS
GEAR HEADS
SOFTWARE
APPENDIX

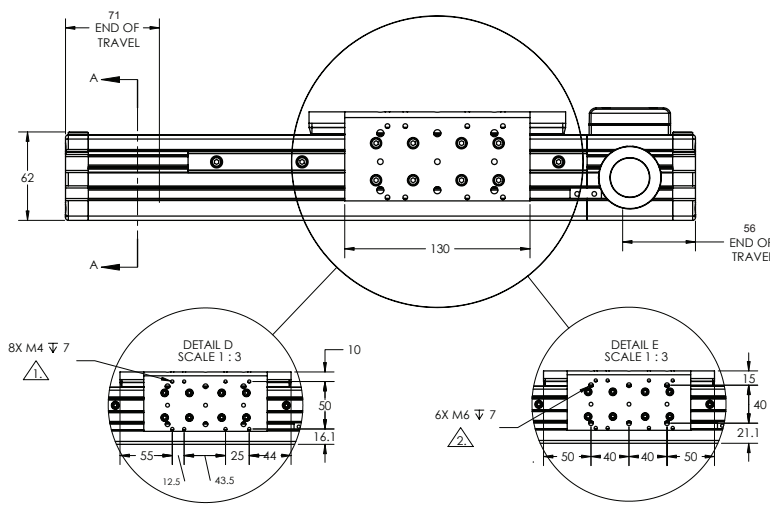
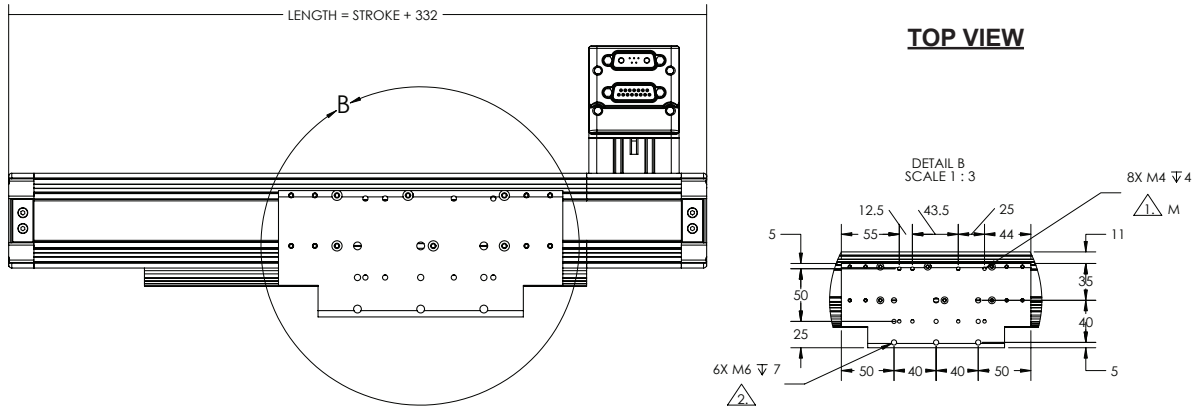

RIGHT SIDE VIEW

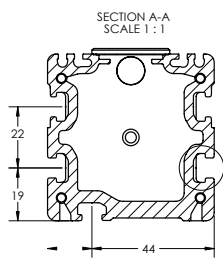

SIMPLE END VIEW

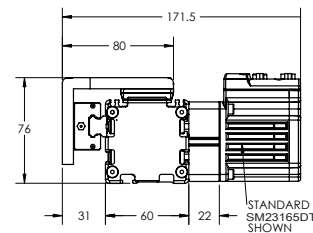
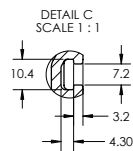

MOTOR END VIEW

NOTES:

- 1. M4 x 50 x 12.5 and M4 x 25 x 50 for mounting L70 actuator.
- 2. M6 x 40 x 40 standard bolt pattern for optional mounting accessories.

Dimensions in millimeters

Note: For part numbers please refer to our Website at www.oemdynamics.com

Thrust Curve performance data in following section on pages 109-126.

HLD60 with Twin External Rails Specifications

Parameter	Value				Units
Configuration & Physical Parameters					
Motor	Animatics Size 23 Motors				-
Coupling	Flexible Jaw				-
Displacement/rev	2.5, 5, 10, 12.5				mm/rev
Position sensors	Optional Home & EOT limits				-
Stroke	100-600mm in 50mm steps 600-1000mm in 100mm steps 1000-2800mm in 200mm steps Custom lengths are available				mm
Overall length (L)	Stroke + 332				mm
Over-travel	25				mm
Unit mass	3.4 + 0.0057 x (stroke, mm) + (motor mass, kg)				kg
Performance					
Unidirectional repeatability	<20				µm
Bi-directional repeatability	60-180 (belt tension dependent)				µm
Accuracy *	0.5 per 300 stroke				mm/mm
Displacement/rev	2.5	5	10	12.5	mm/rev
Linear speed @ 4200RPM	175	350	700	875	mm/s
Payload Mass**	45	40	16	10	kg
Continuous Thrust (Fa)					
SM2315D @ 48V @ 4500RPM	100	20	-	-	N
SM2315DT @ 48V @ 3300RPM	450	230	80	45	N
SM23165D @ 48V @ 4500RPM	260	100	-	-	N
SM23165DT @ 48V @ 3800RPM	450	400	160	135	N
SM23375D @ 48V @ 4500RPM	165	50	-	-	N
SM23375DT @ 48V @ 3200 RPM	450	275	105	65	N
Load Rating, Dynamic ** (Static)					
Fb	3000 (3000)	3000 (3000)	3000 (3000)	2800 (3000)	N
Fc	3000 (3000)	3000 (3000)	3000 (3000)	2800 (3000)	N
Carriage moments, Dynamic ** (Static)					
M.a	180 (200)	144 (200)	114 (200)	106 (200)	Nm
M.b	144 (200)	113 (200)	89 (200)	84 (200)	Nm
M.c	144 (200)	113 (200)	89 (200)	84 (200)	Nm

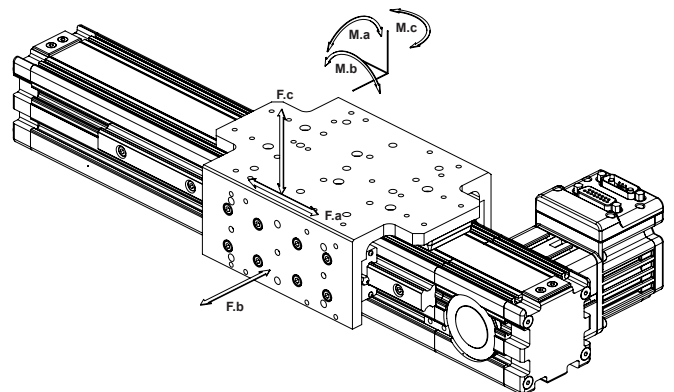
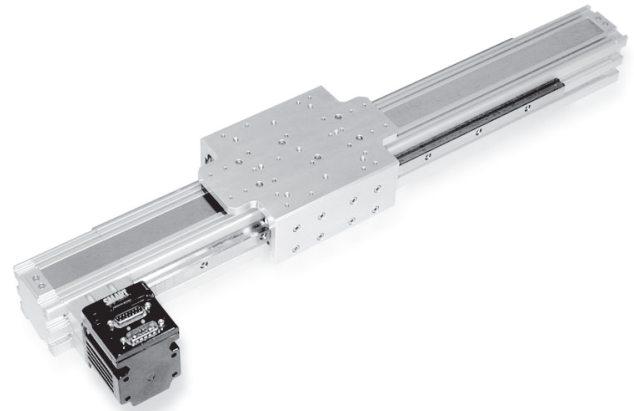

*Consult factory if greater accuracy is required

**Based on a 15000HR service life

@ 75/150/300 & 375mm/s (1800 RPM) average speed at given payload
Subject to routine lubrication

All OEM Dynamics™ Linear Integrated Systems are covered by Animatics patent #5,912,541 and other patents are in progress worldwide

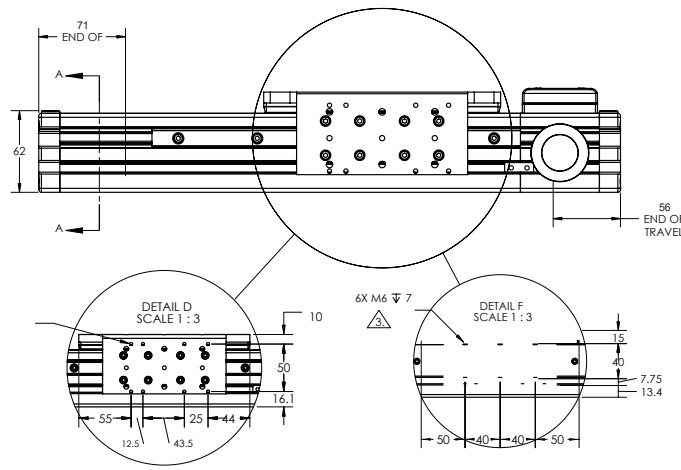
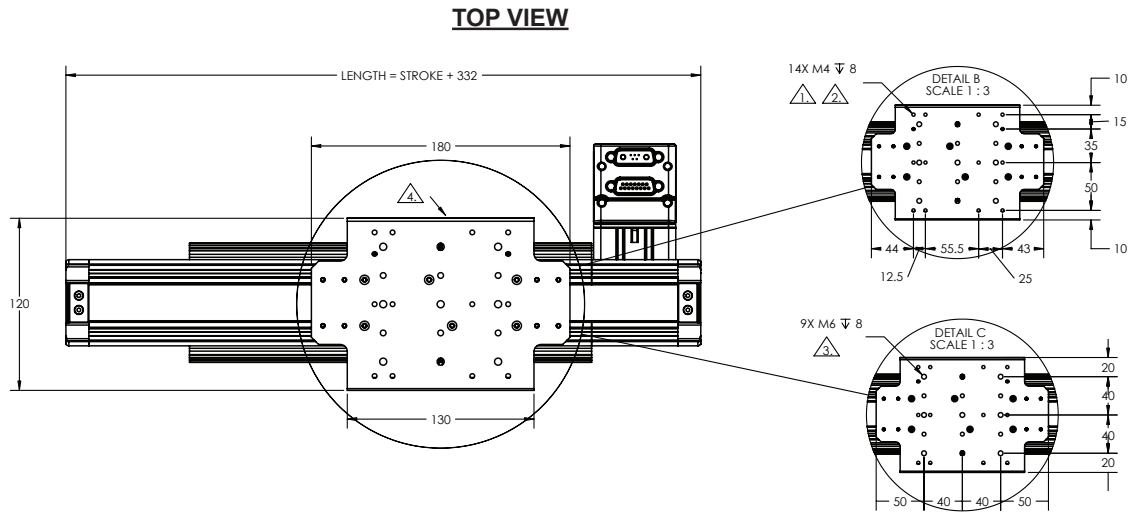

LEFT SIDE VIEW

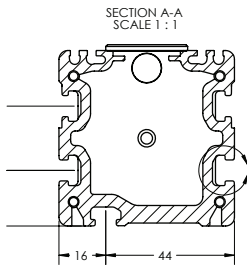

SIMPLE END VIEW

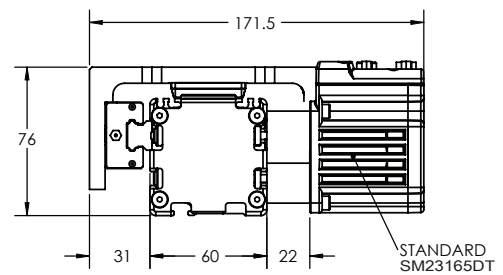

MOTOR END VIEW

- NOTES:**
- 1. M4 x 12.5 x 50 and M4 x 25 x 50 mounting holes for L70 actuator.
 - 2. M4 x 85 x 93 mounting holes for XL100 actuator.
 - 3. M6 x 40 x 40 standard bolt pattern for optional mounting accessories.
 - 4. Simple end (motor-side) has no mounting holes.

Dimensions in millimeters

Note: For part numbers please refer to our Website at www.oemdynamics.com

Thrust Curve performance data in following section on pages 109-126.

L70 Product Specifications

Parameter	Value	Units
Configuration & Physical Parameters		
Motor	Animatics SmartMotors Size 17 & 23	-
Coupling	Beam	-
Ball Screw Leads	5, 10	mm/rev
Position Sensors	Adjustable (3 max) NPN N/O or N/C	-
Stroke Lengths	Standard in 50mm increments to 600 Custom in 1mm increments to 600	mm
Overall Length	Stroke + 182.5 + Motor	mm
Over-Travel	24.5	mm
Unit Mass	1.29 + 0.00414 x (stroke, mm) + (motor mass, kg)	kg
Performance		
Unidirectional Repeatability	3	μm
Bi-directional Repeatability	16	μm
Ball screw Lead Accuracy	0.1/300	mm/mm
Load Rating, Dynamic* (Static)		
Payload Mass	25 or 20 (5 or 10 mm/rev lead)	kg
F. t, Thrust	200 (1140)	N
F.n, Carriage Normal	200 (400)	N
F.st, Carriage Side	200 (400)	N
F.ss, Carriage Side	100 (400)	N
M.a, Carriage Moment**	5 (20)	Nm
M.b, Carriage Moment**	5 (20)	Nm
M.c, Carriage Moment**	5 (20)	Nm

*Based on a basic desired service life of 15,000hr (7.5yrs single shift) @ 167 mm/s and 333mm/s (2000 RPM) average speed at given payload. Consult the factory if your application exceeds these values.

**Moment capacities given about center of carriage mounting surface.

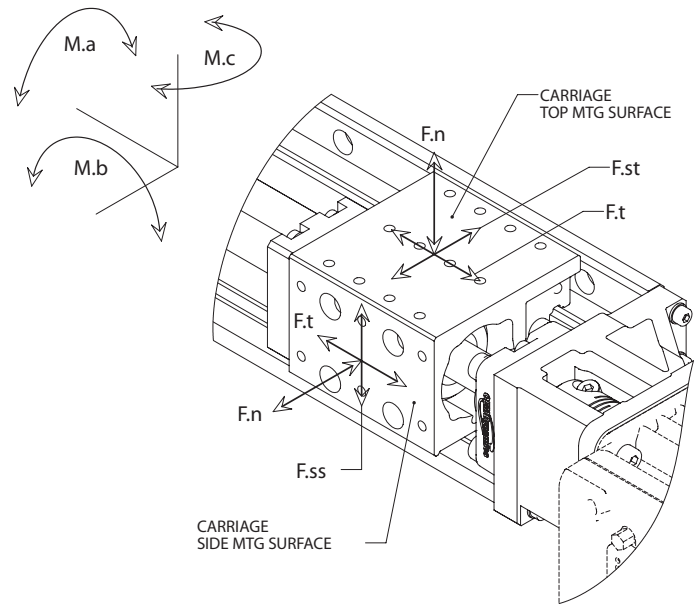
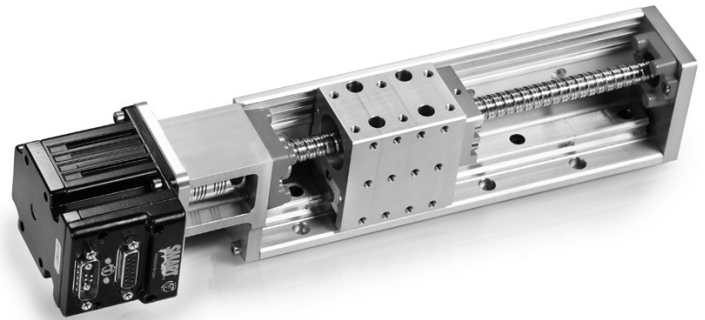

WARNING: Do not exceed these limits

L70 - Maximum Permissible Carriage Velocity

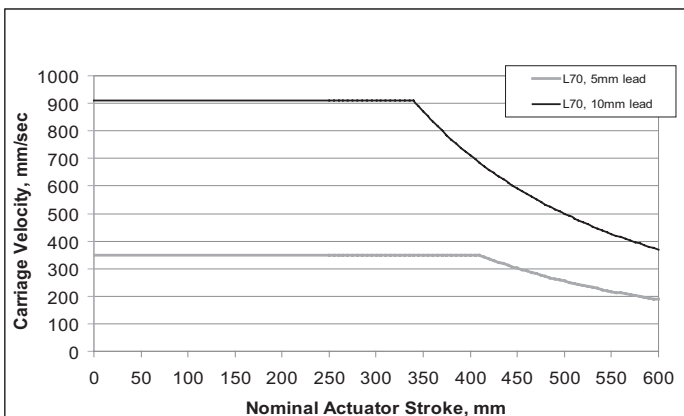

L70 - Maximum Permissible Screw Speed

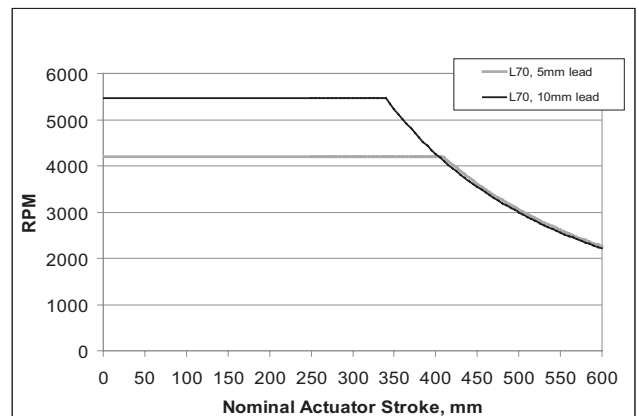

OVERVIEW
MOTOR SPECIFICATIONS
LINEAR SYSTEMS
CONNECTIVITY
PERIPHERALS
IP 65 MODELS & CONNECTIVITY
POWER SUPPLIES & SHUNTS
GEAR HEADS
SOFTWARE
APPENDIX

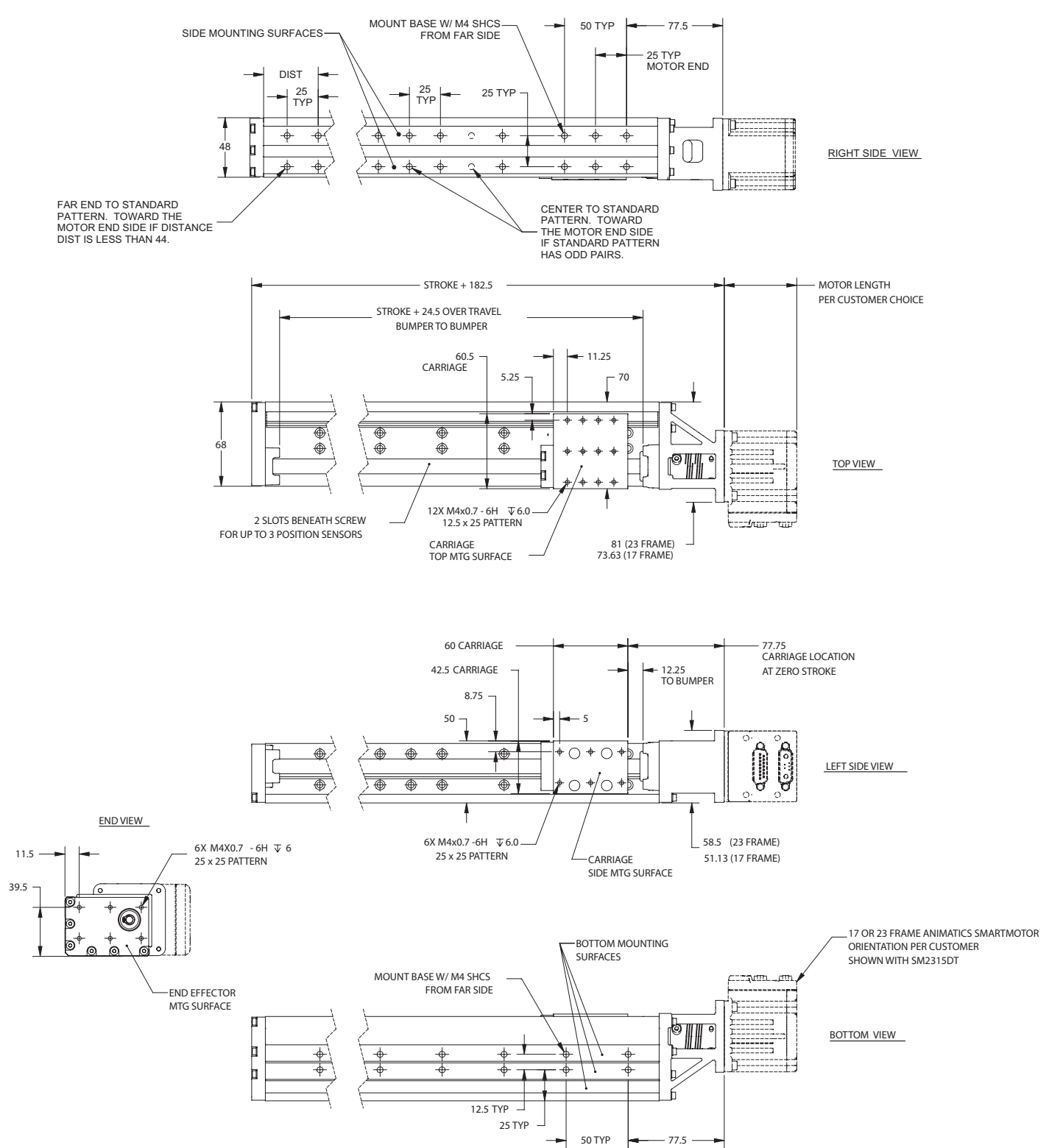

Dimensions in millimeters

Note: For part numbers please refer to our Website at www.oemdynamics.com

Thrust Curve performance data in following section on pages 109-126.

XL100 Product Specifications

Parameter	Value	Units
Configuration & Physical Parameters		
Motor	Animatics SmartMotors Size 17 & 23	-
Coupling	Beam	-
Ball Screw Leads	5, 10	mm/rev
Position Sensors	Adjustable (3 per side - 6 max)) NPN N/O or N/C	-
Stroke Lengths	Standard in 50mm increments to 600 Custom in 1mm increments to 600	mm
Overall Length	Stroke + 223.50 + Motor	mm
Over-Travel	24.5	mm
Unit Mass	2.657 + 0.0049 x (stroke, mm) + (motor mass, kg)	kg
Performance		
Unidirectional Repeatability	3	μm
Bi-directional Repeatability	16	μm
Ballscrew Lead Accuracy	0.1/300	mm/mm
Load Rating, Dynamic* (Static)		
Payload Mass	25 or 20 (5 or 10mm/rev lead)	kg
F. t, Thrust	200 (1140)	N
F.n, Carriage Normal	860 (15000)	N
F.st, Carriage Side	580 (1000)	N
M.a, Carriage Moment**	25 (500)	Nm
M.b, Carriage Moment**	25 (500)	Nm
M.c, Carriage Moment**	25 (500)	Nm

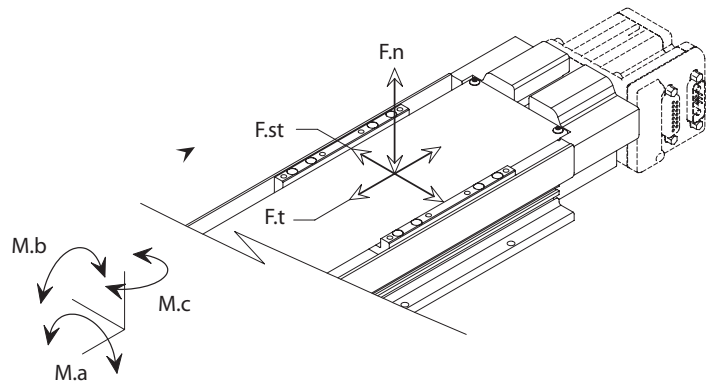

*Based on a basic desired service life of 15,000hr (7.5yrs single shift) @ 167 mm/s and 333mm/s (2000 RPM) average speed at given payload. Consult the factory if your application exceeds these values.
**Moment capacities given about center of carriage mounting surface.

WARNING: Do not exceed these limits

XL100 - Maximum Permissible Carriage Velocity

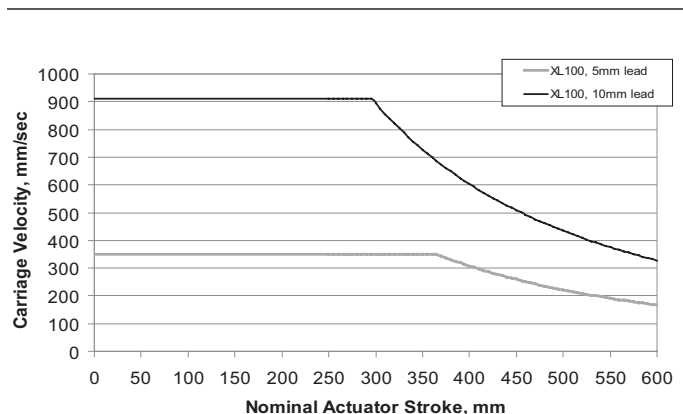

XL100 - Maximum Permissible Screw Speed

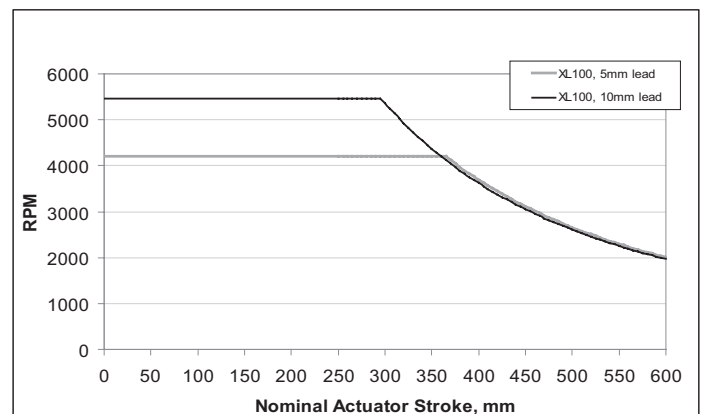

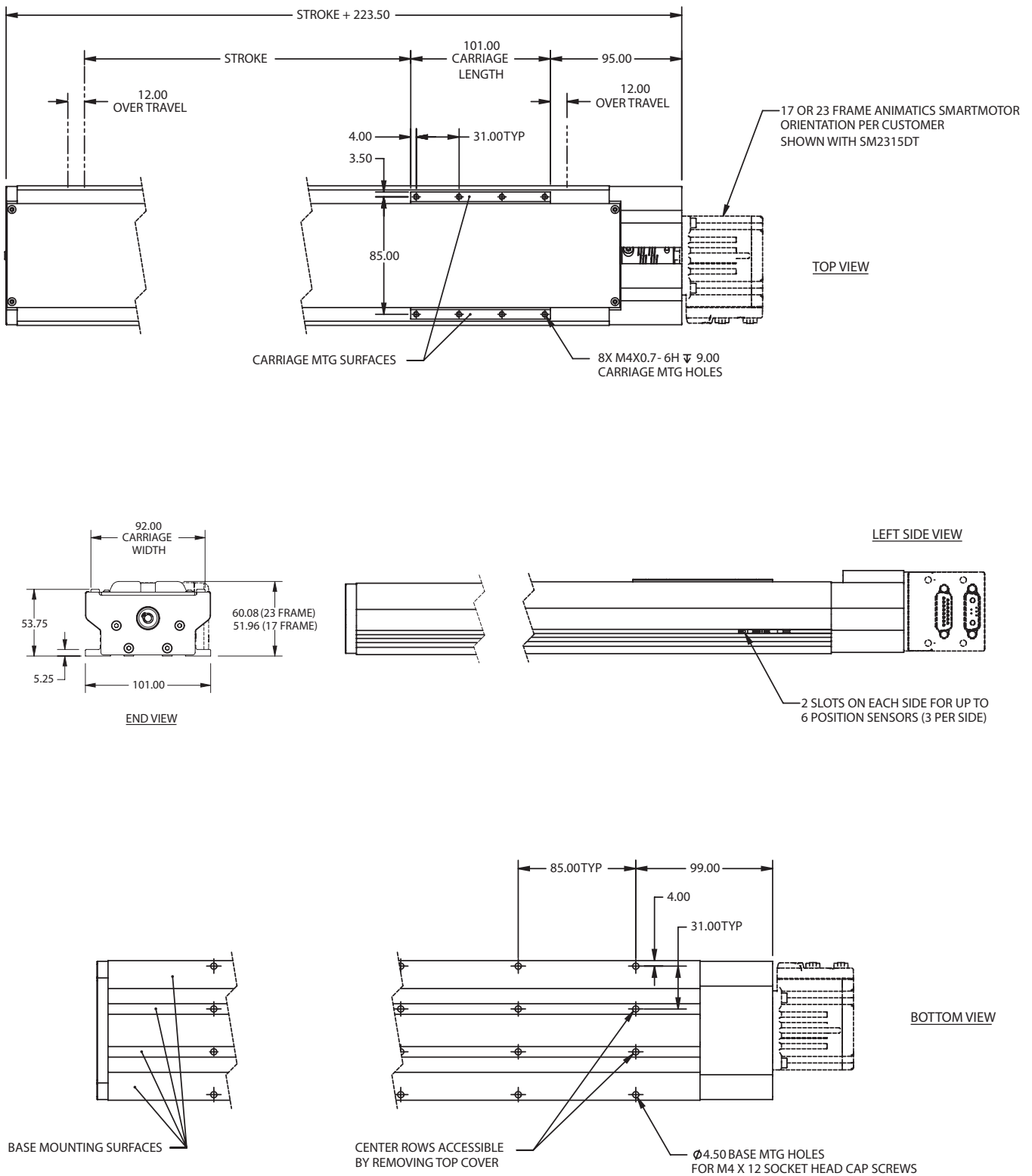

Dimensions in millimeters

Note: For part numbers please refer to our Website at www.oemdynamics.com

Thrust Curve performance data in following section on pages 109-126.

VL-ST45 Product Specifications

Parameter	Value	Units
Configuration & Physical Parameters		
Motor	Animatics SmartMotors Size 23	-
Coupling	Beam	-
Ball Screw Leads	6, 12	mm/rev
Position Sensors	consult factory	-
Stroke Lengths	50-500mm in 50mm steps	mm
Overall Length	Stroke + 222	mm
Over-Travel	Approx 10	mm
Unit Mass	1.38 + (stroke, mm)*0.0021	kg
Performance		
Unidirectional Repeatability	20	µm
Bi-directional Repeatability	40	µm
Accuracy	0.021/300	mm/mm
Max Velocity	up to 1000 (stroke dependant)	mm/s
Max Acceration	0.3	G
Leads	6 12	mm/rev
Payload Mass	8 6.5	kg
Rated Velocity	200 400	mm/s
Lifetime*	15000	hr
Load Rating, Dynamic* (Static)		
Max Continuous Thrust	488 245	N
Max Peak Thrust	660 330	N
M.a, Carriage Moment	4.47 (31) 3.44 (31)	N*m
M.b, Carriage Moment	1.64 (12) 1.33 (12)	N*m
M.b, Carriage Moment	1.64 (12) 1.33 (12)	N*m

* Based on operating at an average speed of the rated velocity at the given payload. The Lifetime will be significantly reduced operating above the Rated Velocity and/or given payload.



VL-ST45

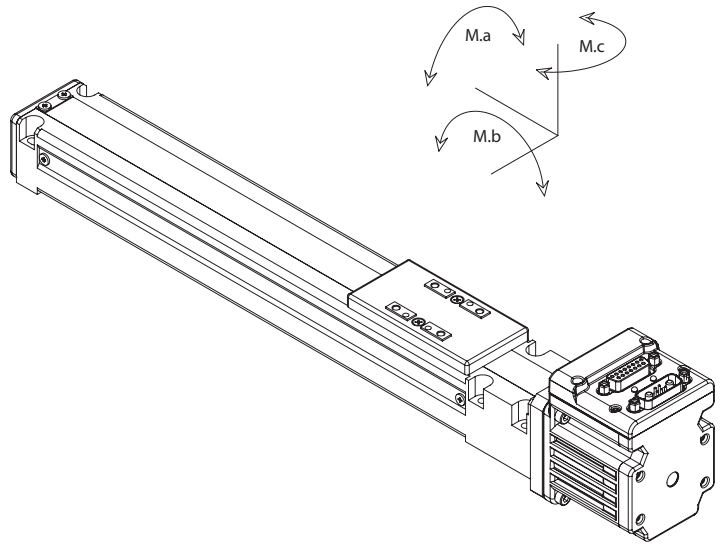

WARNING: Do not exceed these limits

VL-ST45 - Maximum Permissible Carriage Velocity

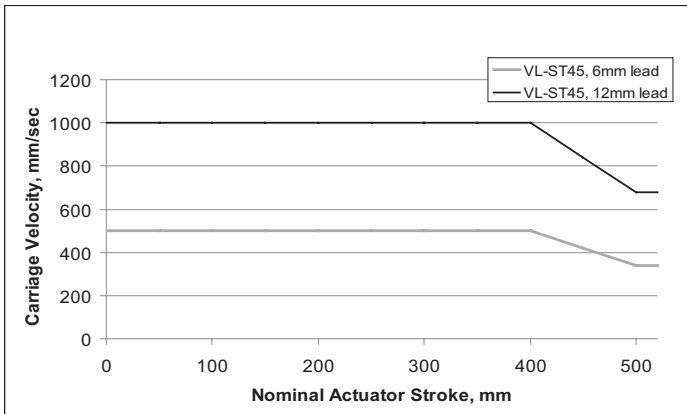

VL-ST series - Maximum Permissible Screw Speed

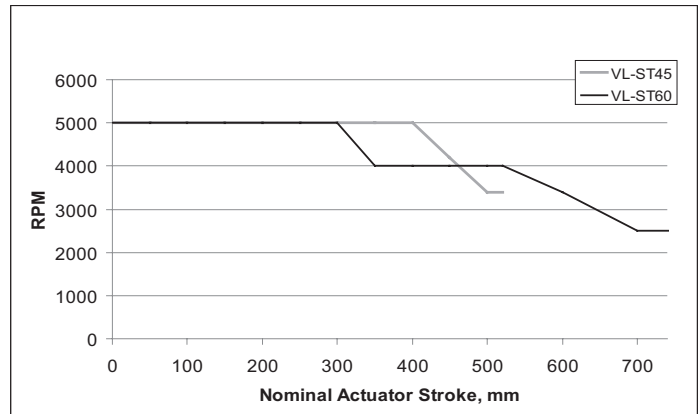

OVERVIEW | MOTOR SPECIFICATIONS | LINEAR SYSTEMS | CONNECTIVITY | PERIPHERALS | IP 65 MODELS & CONNECTIVITY | POWER SUPPLIES & SHUNTS | GEAR HEADS | SOFTWARE | APPENDIX

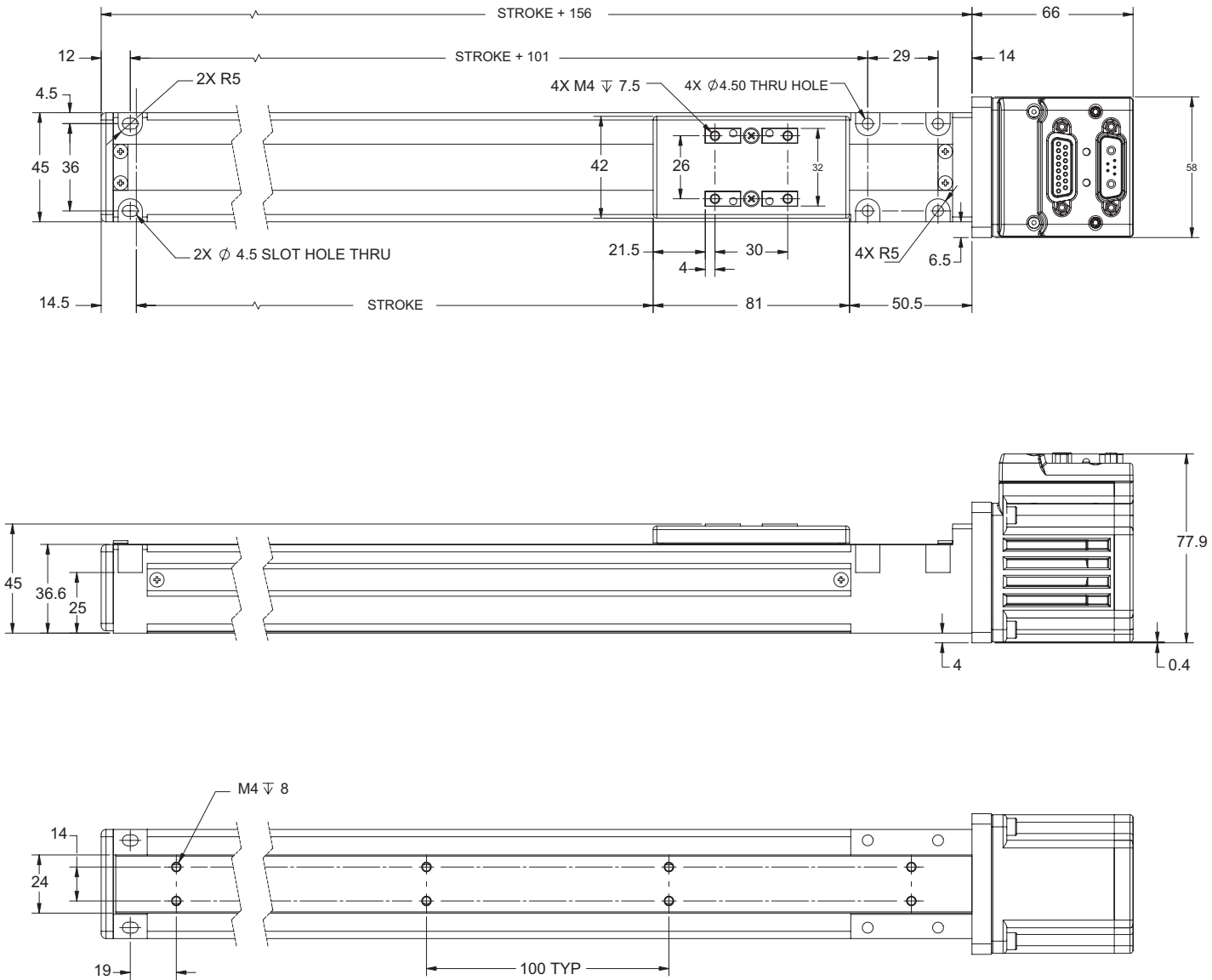

Dimensions in millimeters

Note: For part numbers please refer to our Website at www.oemdynamics.com

Thrust Curve performance data in following section on pages 109-126.

VL-ST60 Product Specifications

Parameter	Value	Units	
Configuration & Physical Parameters			
Motor	Animatics SmartMotors Size 23	-	
Coupling	Beam	-	
Ball Screw Leads	6, 12	mm/rev	
Position Sensors	consult factory	-	
Stroke Lengths	50-600mm in 50mm steps + 700mm	mm	
Overall Length	Stroke + 156 + motor	mm	
Over-Travel	Approx 10	mm	
Unit Mass	1.3349 + (stroke, mm)*0.0039	kg	
Performance			
Unidirectional Repeatability	20	µm	
Bi-directional Reapeatability	40	µm	
Accuracy	0.021/300	mm/mm	
Max Velocity	250 -1000 (stroke dependant)	mm/s	
Max Acceration	0.3	G	
Leads	6	12	mm/rev
Payload Mass	13	10	kg
Rated Velocity	200	400	mm/s
Lifetime*	15000	hr	
Load Rating, Dynamic* (Static)			
Max Continuous Thrust	491	245	N
Max Peak Thrust	788	394	N
M.a, Carriage Moment	11.47 (58)	9 (58)	N*m
M.b, Carriage Moment	3.57 (25)	2.75 (25)	N*m
M.b, Carriage Moment	3.57 (25)	2.75 (25)	N*m

* Based on operating at an average speed of the rated velocity at the given payload. The Lifetime will be significantly reduced operating above the Rated Velocity and/or given payload



VL-ST60

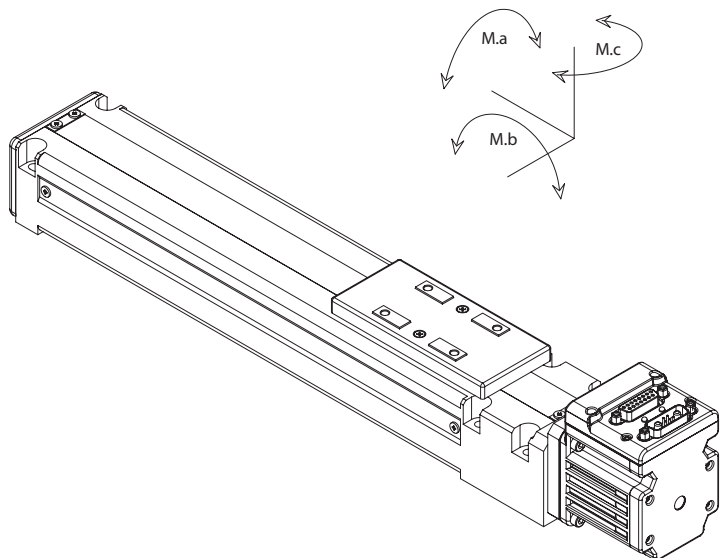

WARNING: Do not exceed these limits

VL-ST60 - Maximum Permissible Carriage Velocity

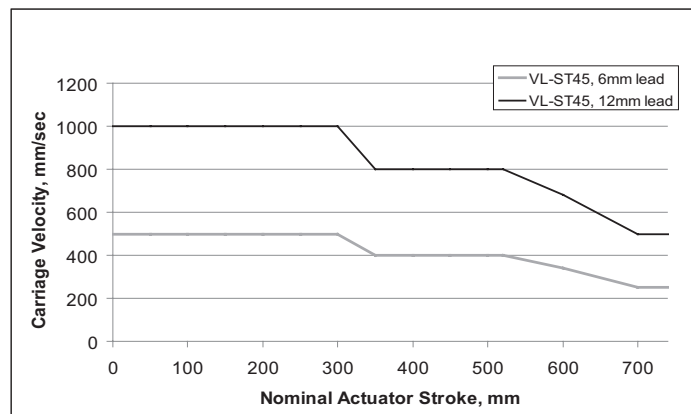

VL-ST series - Maximum Permissible Screw Speed

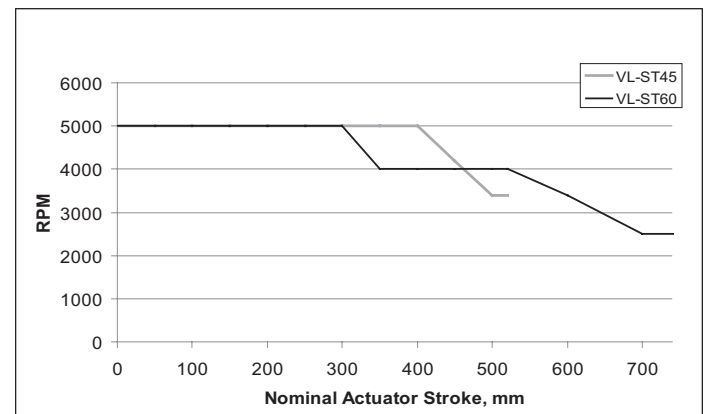

OVERVIEW MOTOR SPECIFICATIONS LINEAR SYSTEMS CONNECTIVITY PERIPHERALS IP 65 MODELS & CONNECTIVITY POWER SUPPLIES & SHUNTS GEAR HEADS SOFTWARE APPENDIX

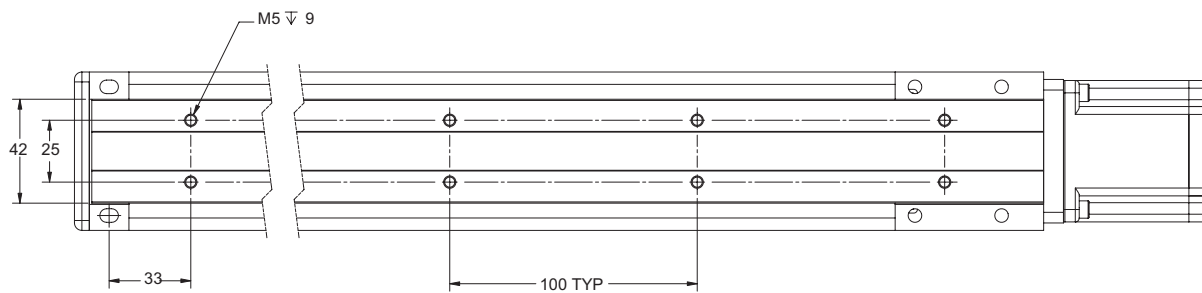
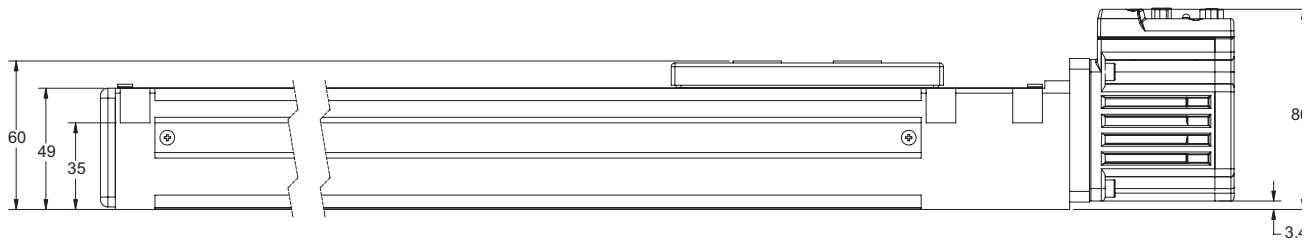
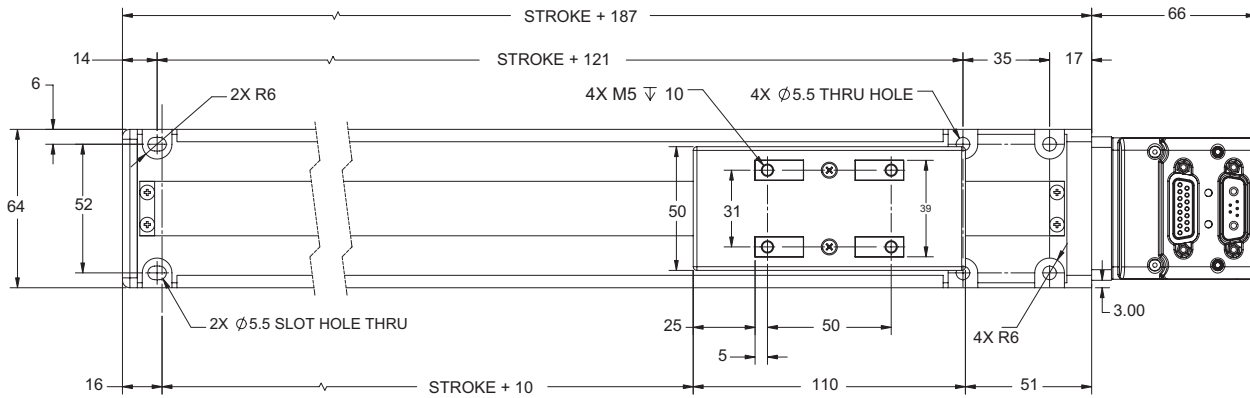

Dimensions in millimeters

Note: For part numbers please refer to our Website at www.oemdynamics.com

Thrust Curve performance data in following section on pages 109-126.

VL-CT35 Series Specifications

Parameter	Value	Units	
Configuration & Physical Parameters			
Motor	Animatics SmartMotors Size 23	-	
Coupling	Beam	-	
Ball Screw Leads	12	mm/rev	
Position Sensors	consult factory	-	
Stroke Lengths	50, 100 and 150	mm	
Overall Length	Stroke + 244.9	mm	
Over-Travel	0	mm	
Unit Mass	1.1667 + (stroke, mm)*0.003	kg	
Performance			
Unidirectional Repeatability	20	µm	
Bi-directional Reapeatability	40	µm	
Accuracy	0.021/300	mm/mm	
Max Velocity	470 -1000 (stroke dependant)	mm/s	
Max Acceration	0.3	G	
Payload Mass	5.6	kg	
Rated Velocity	400	mm/s	
Lifetime*	15000	hr	
Load Rating, Dynamic			
Using SM23165DT motor	Direct Drive	2:1 pulley**	-
Max Continuous Thrust	245	490	N
Max Peak Thrust	394	565	N

* Based on operating at an average speed of the rated velocity at the given payload. The Lifetime will be significantly reduced operating above the Rated Velocity and/or given payload.

**Please see pages 104 for pulley offset CAD drawings.



VL-CT35 series

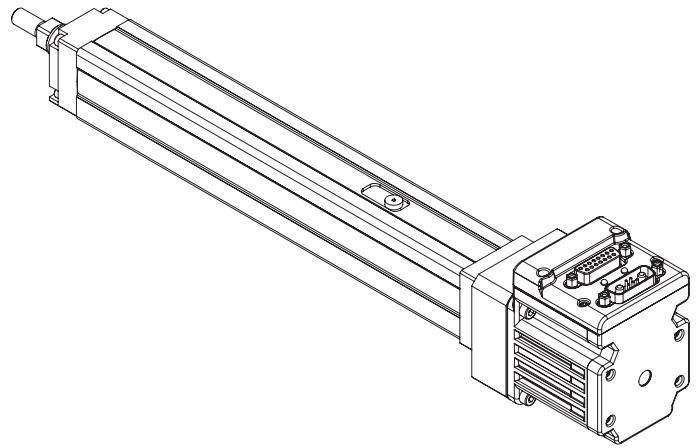

WARNING: Do not exceed these limits

VL-CT series - Maximum Permissible Carriage Velocity

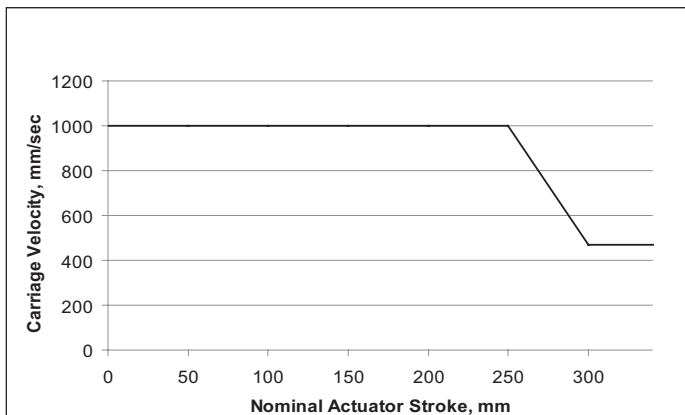

VL-CT series - Maximum Permissible Screw Speed

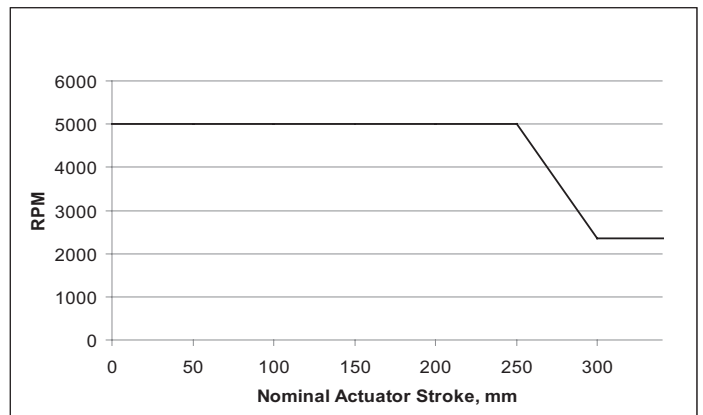

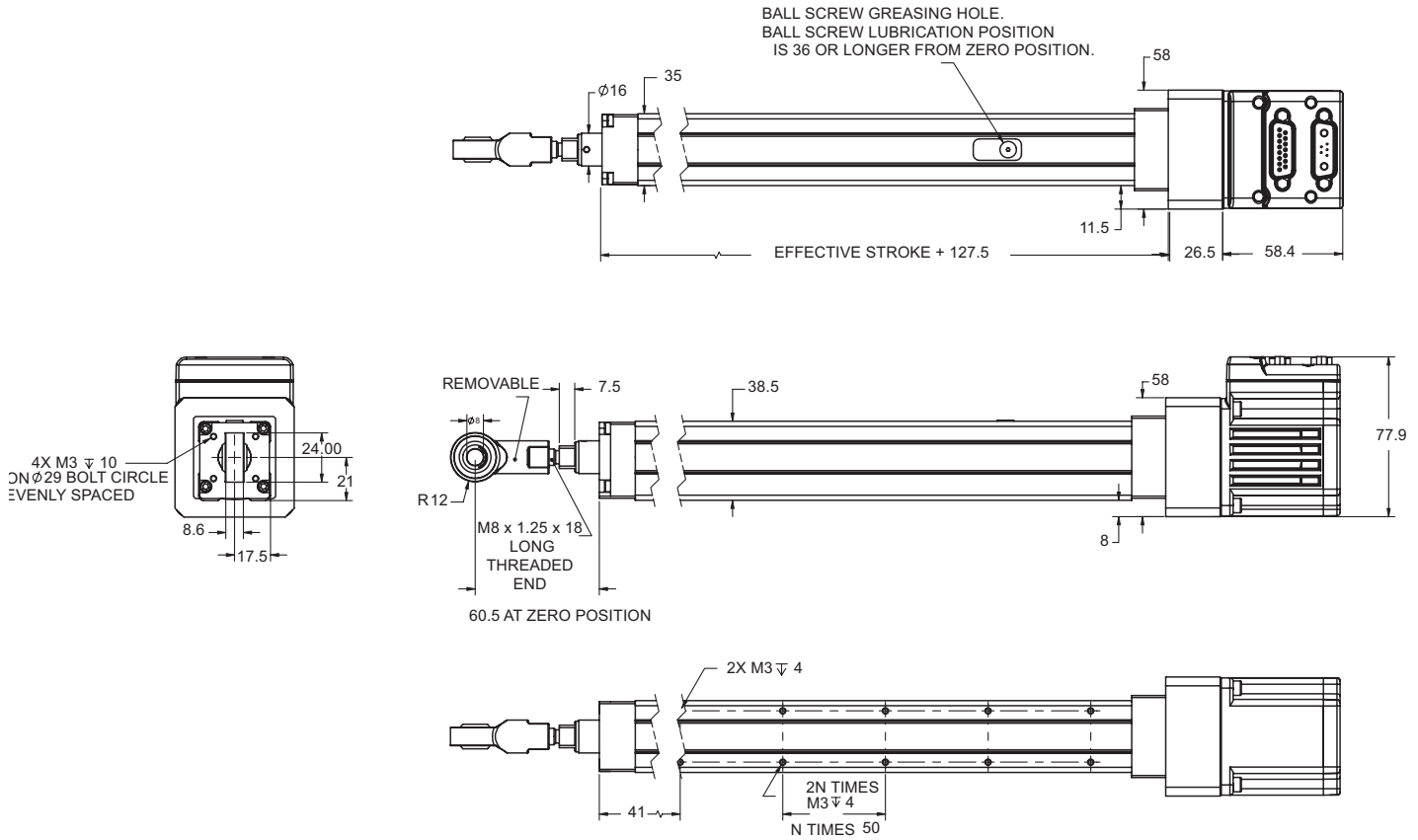

Dimensions in millimeters

Note: For part numbers please refer to our Website at www.oemdynamics.com

Thrust Curve performance data in following section on page 109-126.

VL-CT45 Series Specifications

Parameter	Value	Units	
Configuration & Physical Parameters			
Motor	Animatics SmartMotors NEMA 23	-	
Coupling	Beam	-	
Ball Screw Leads	12	mm/rev	
Position Sensors	consult factory	-	
Stroke Lengths	50, 100, 150 and 200	mm	
Overall Length	Stroke + 251.4	mm	
Over-Travel	0	mm	
Unit Mass	1.45 + (stroke, mm)*0.0052	kg	
Performance			
Unidirectional Repeatability	20	µm	
Bi-directional Reapeatability	40	µm	
Accuracy	0.021/300	mm/mm	
Max Velocity	470 -1000 (stroke dependant)	mm/s	
Max Acceration	0.3	G	
Payload Mass	5.6	kg	
Rated Velocity	400	mm/s	
Lifetime*	15000	hr	
Load Rating, Dynamic			
Using SM23165DT motor	Direct Drive	2:1 pulley**	-
Max Continuous Thrust	245	490	N
Max Peak Thrust	394	565	N

* Based on operating at an average speed of the rated velocity at the given payload. The Lifetime will be significantly reduced operating above the Rated Velocity and/or given payload..

**Please see pages 105 for pulley offset CAD drawings.



VL-CT45

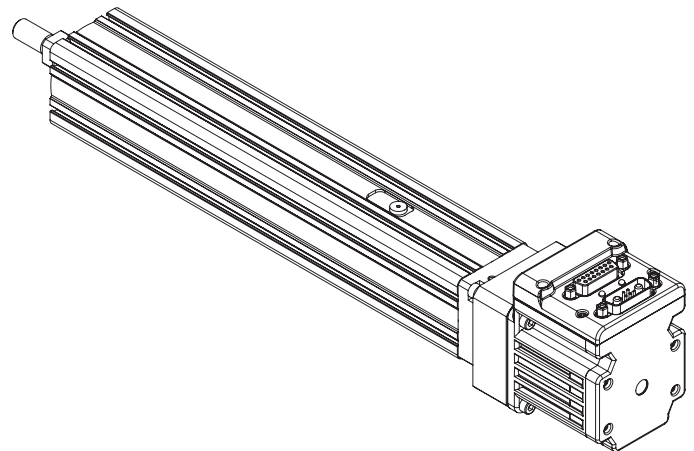

WARNING: Do not exceed these limits

VL-CT series - Maximum Permissible Carriage Velocity

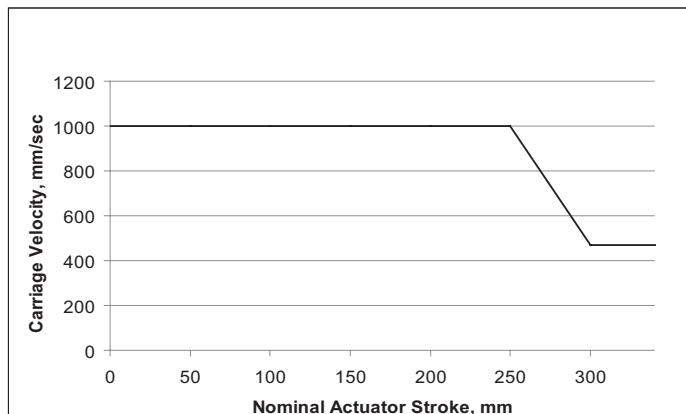

VL-CT series - Maximum Permissible Screw Speed

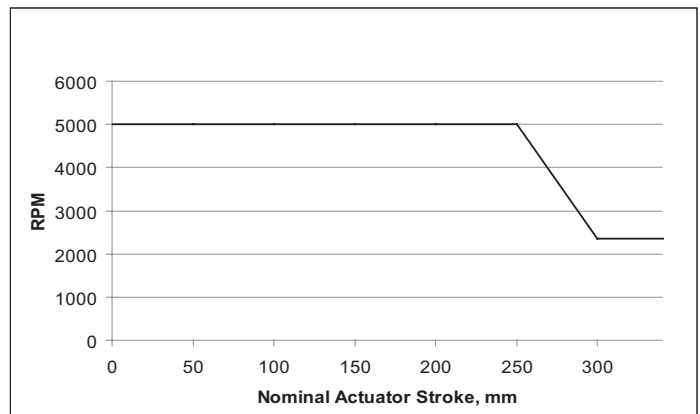

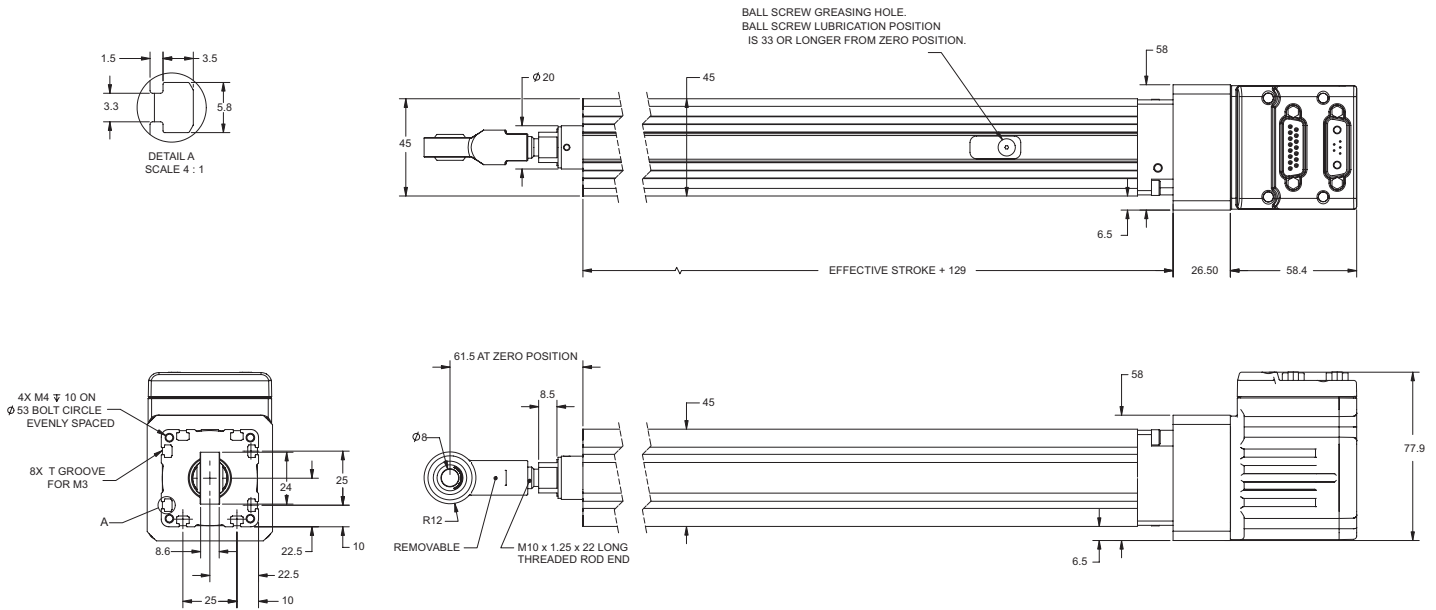

Dimensions in millimeters

Note: For part numbers please refer to our Website at www.oemynamics.com

Thrust Curve performance data in following section on page 109-126.

VL-CT55 Series Specifications

Parameter	Value	Units		
Configuration & Physical Parameters				
Motor	Animatics SmartMotors NEMA 23	-		
Coupling	Beam	-		
Ball Screw Leads	12	mm/rev		
Position Sensors	consult factory	-		
Stroke Lengths	50 - 300mm in 50mm steps	mm		
Overall Length	Stroke + 274.9	mm		
Over-Travel	0	mm		
Unit Mass	1.94 + (stroke, mm)*0.0075	kg		
Performance				
Unidirectional Repeatability	20	µm		
Bi-directional Reapeatability	40	µm		
Accuracy	0.021/300	mm/mm		
Max Velocity	470 -1000 (stroke dependant)	mm/s		
Max Acceration	0.3	G		
Payload Mass	22	kg		
Rated Velocity	400	mm/s		
Lifetime*	15000	hr		
Load Rating, Dynamic				
Using SM23165DT motor	Direct Drive	2:1 pulley**	3:1 pulley**	-
Max Continuous Thrust	262	490	737	N
Max Peak Thrust	394	788	1182	N

* Based on operating at an average speed of the rated velocity at the given payload. The Lifetime will be significantly reduced operating above the Rated Velocity and/or given payload.

**Please see pages 105 for pulley offset CAD drawings.



VL-CT55 series - Direct Drive

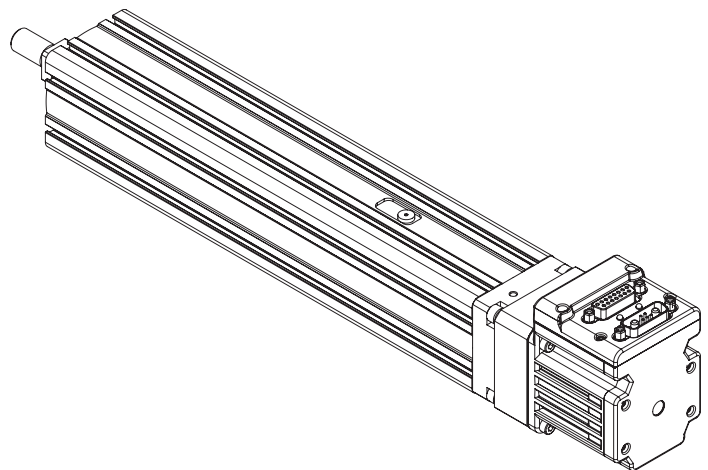

WARNING: Do not exceed these limits

VL-CT series - Maximum Permissible Carriage Velocity

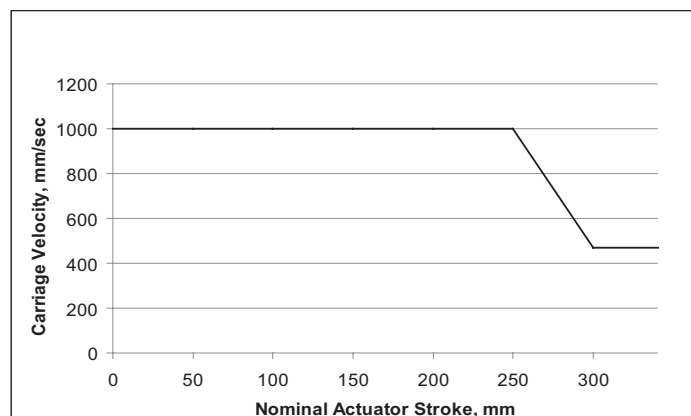

VL-CT series - Maximum Permissible Screw Speed

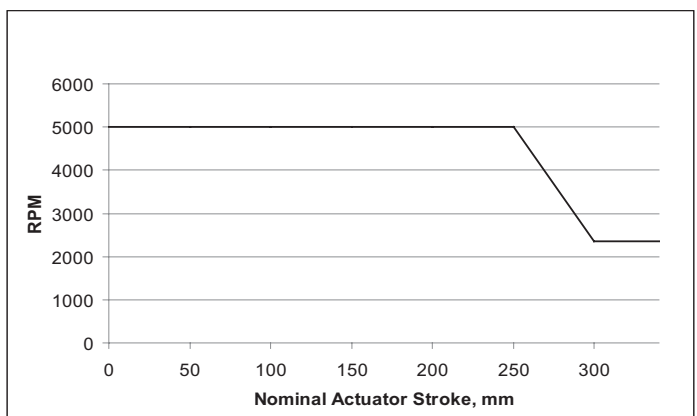

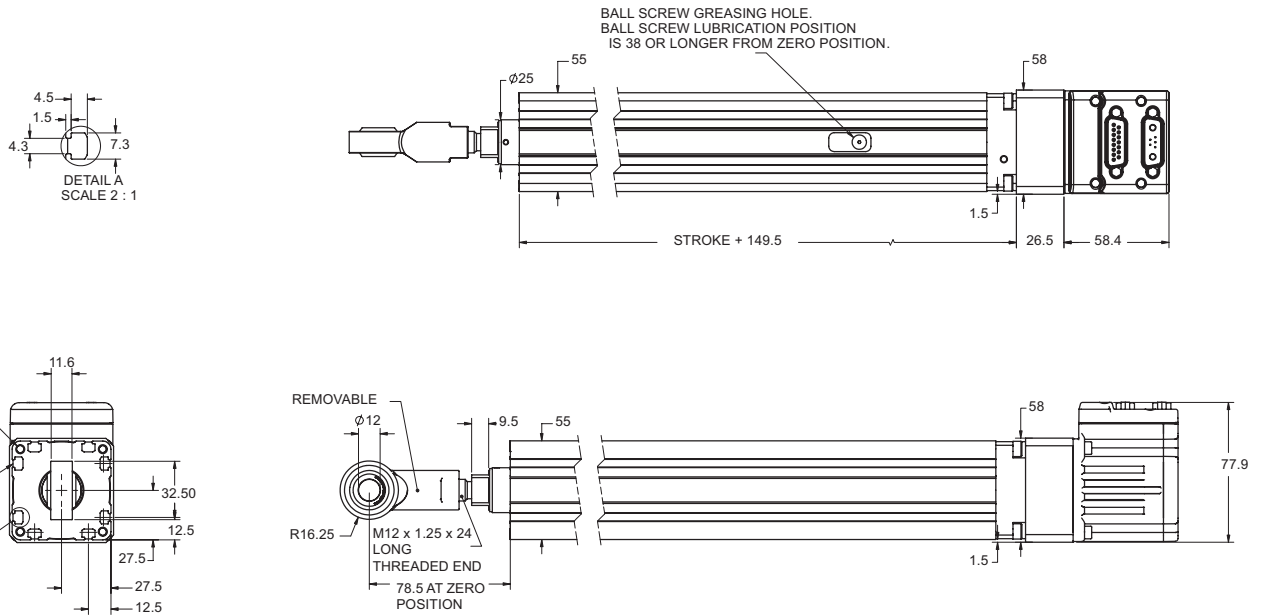

Dimensions in millimeters

Note: For part numbers please refer to our Website at www.oemdynamics.com

Thrust Curve performance data in following section on page 109-126

OVERVIEW
MOTOR SPECIFICATIONS
LINEAR SYSTEMS
CONNECTIVITY
PERIPHERALS
IP 65 MODELS & CONNECTIVITY
POWER SUPPLIES & SHUNTS
GEAR HEADS
SOFTWARE
APPENDIX

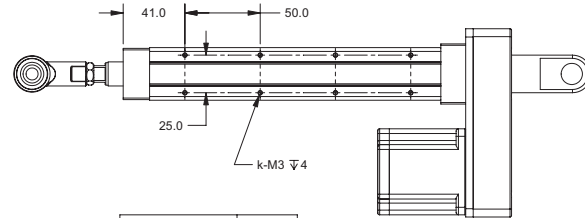
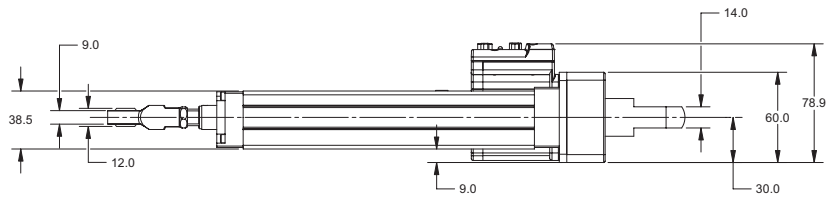
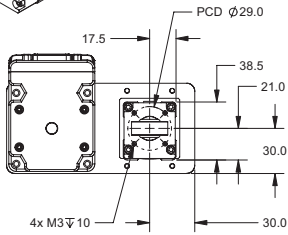
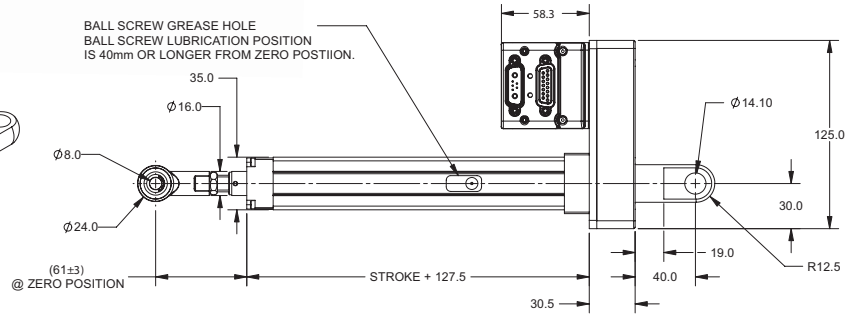
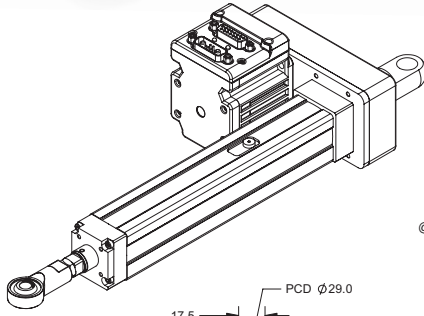
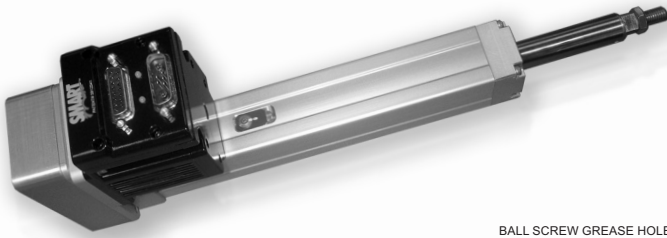

STROKE LENGTH	k
50	6
100	8
150	10

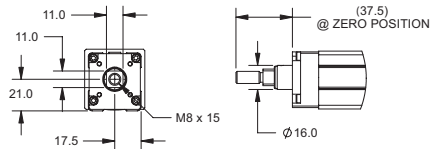

VL-CT35 with SM23165DT or SM23165D, with Pulley Offset

*Tie rods are available.

WARNING: Do not exceed these limits

VL-CT series - Maximum Permissible Carriage Velocity

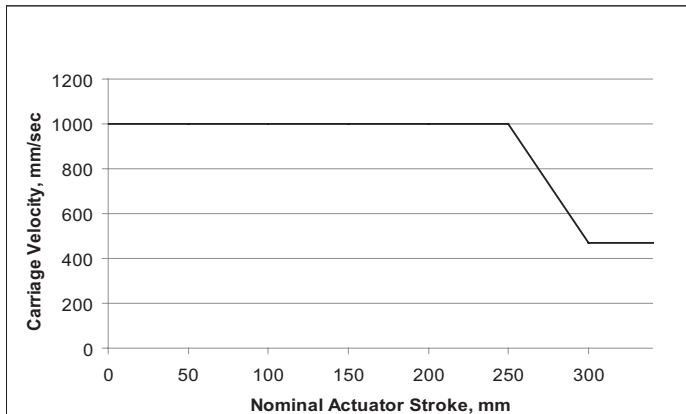

VL-CT series - Maximum Permissible Screw Speed

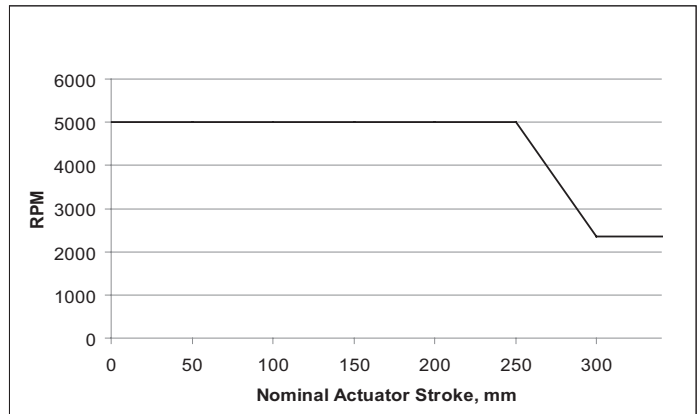

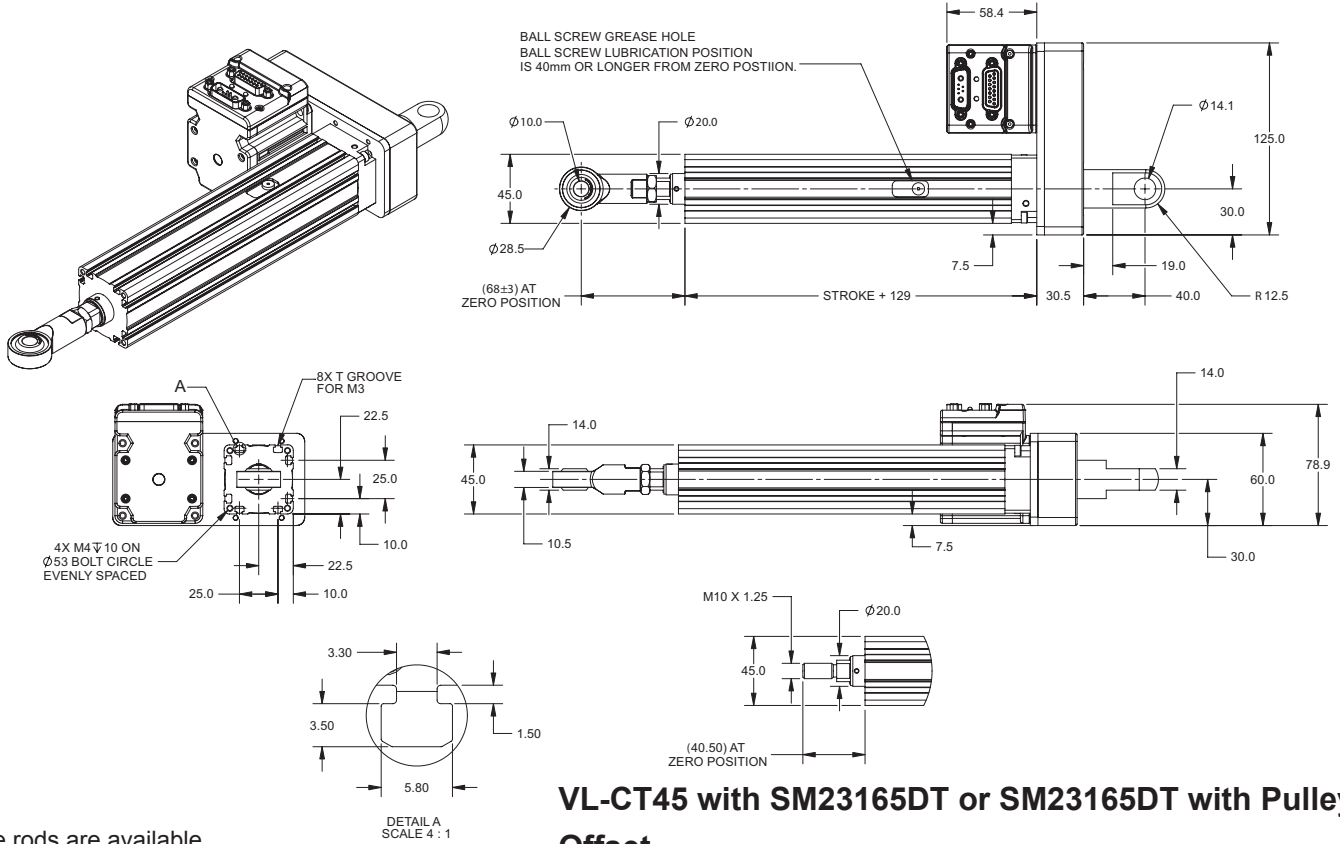

*Tie rods are available.

VL-CT45 with SM23165DT or SM23165DT with Pulley Offset

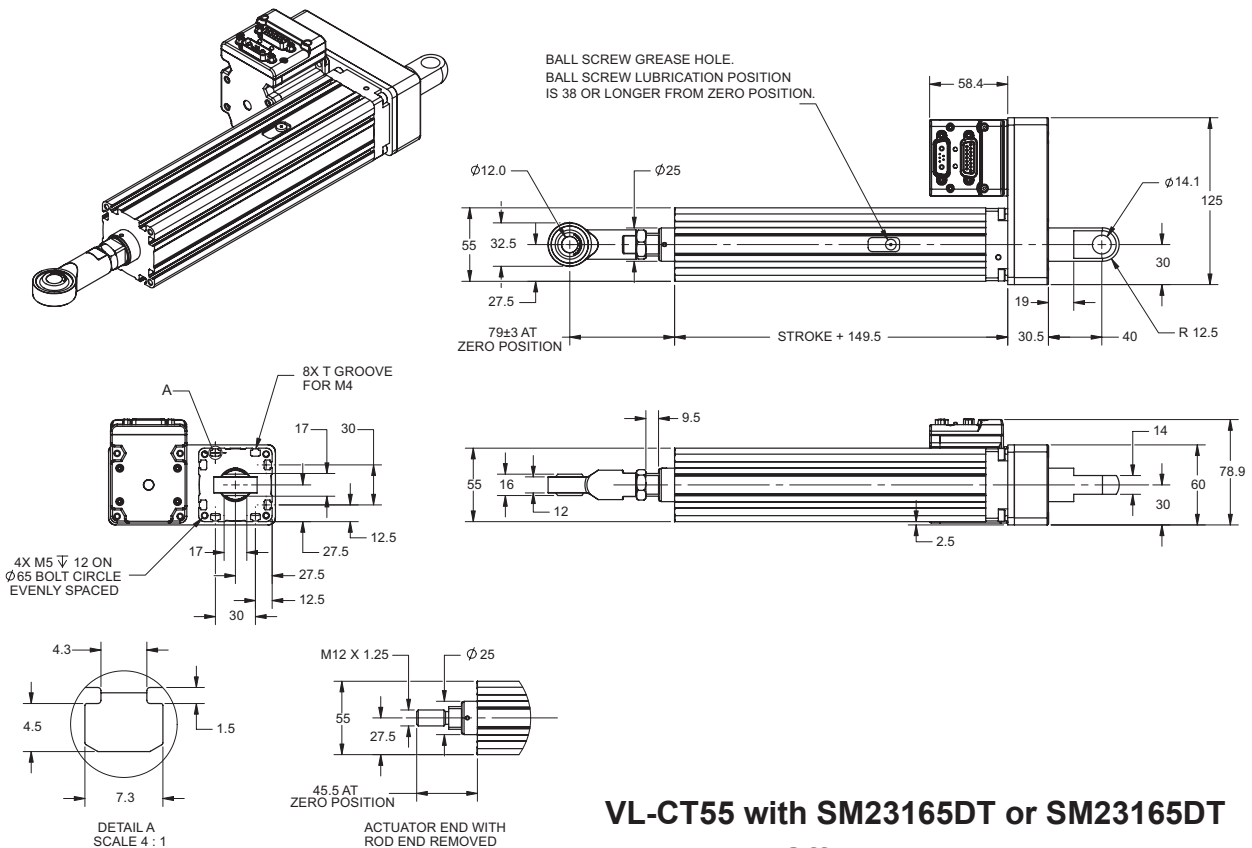

*Tie rods are available.

VL-CT55 with SM23165DT or SM23165DT with Pulley Offset

Multi-Axis Configurations

OVERVIEW

MOTOR SPECIFICATIONS

LINEAR SYSTEMS

CONNECTIVITY

PERIPHERALS

IP 65 MODELS & CONNECTIVITY

POWER SUPPLIES & SHUNTS

GEAR HEADS

SOFTWARE

APPENDIX

HLD60 Twin Rails with L70 2 Axis System

The configuration shown in the picture to the right includes 1 HLD actuator with twin external rails and 1 L70 actuator. This is a close up of the mounting plate which is available. Mounting plates are also available for mounting a XL100 to an HLD actuator.

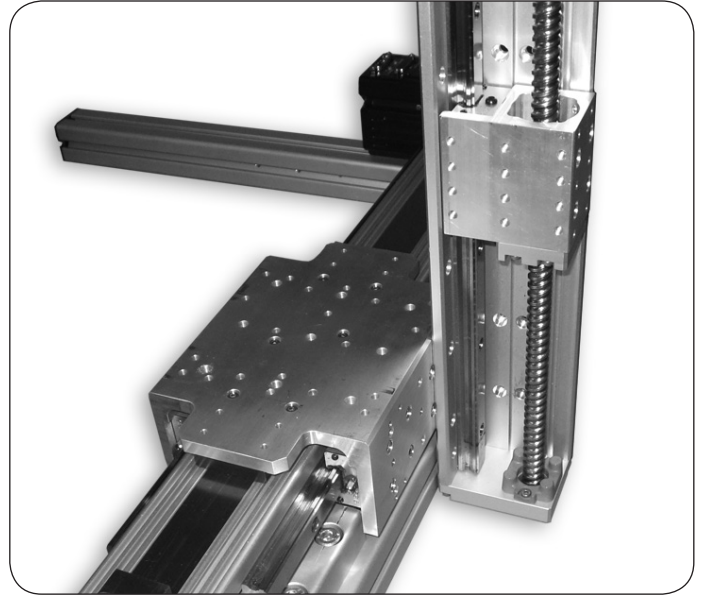

L70 Series 3 Axis X-Y-Z

The configuration shown in the picture to the right includes 4 L70 ball screw actuators. No mounting brackets are needed when mounting an L70 actuator to itself. SmartMotors™ have a mode follow option which will allow a Master and Slave axis.

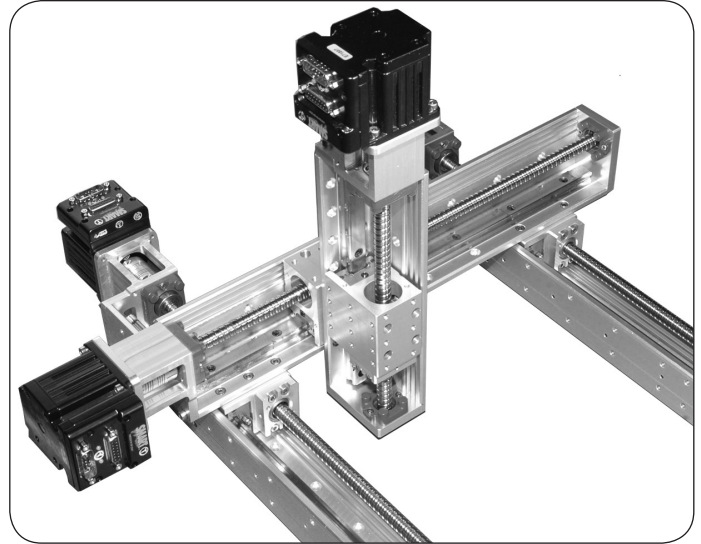

HLD60 with L70 3 Axis System

The configuration shown in the picture to the right includes 2 HLD actuators – 1 with a single external rail and 1 HLD actuator with twin external rails. Toe clamps are available for mounting the HLD actuators together. In this picture, there are 2 different sizes of toe clamps used.

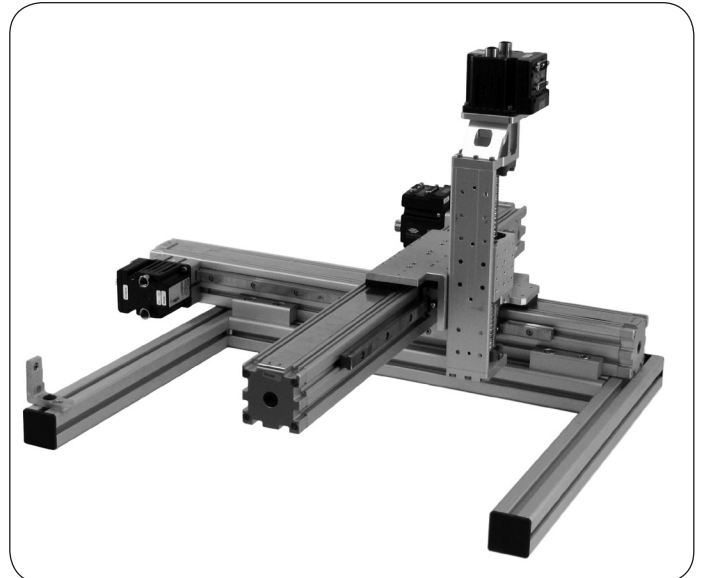

Note: We highly recommend all stand-alone multi-axis systems be ordered with Combitronic CAN interface option via -C or -DN part number add-in

Multi-Axis Configurations

L70 Series 2 Axis X-Y

The L70 series is designed with mounting holes for easy X-Y setup. The “L” shape provides a means to mount to either top or side of the carriage for up to 4 configurations of X-Y mounting.

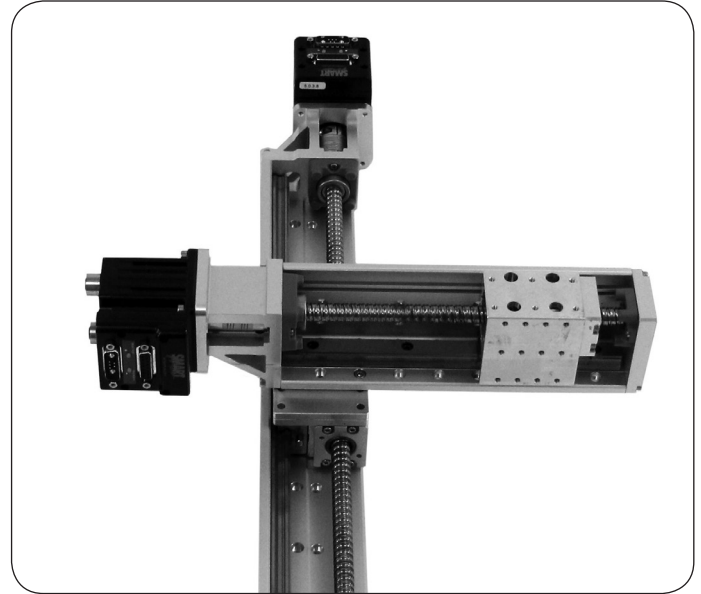

XL100 series 2-Axis X-Y

The XL100 series has mounting holes along the base of the extrusion to allow easy stacking without the need for a transition plate. Given the twin rail extended Moment loading capabilities, one axis can be fully cantilevered off of the other with <math><0.2\text{mm}</math> deflection at full load at 500mm.

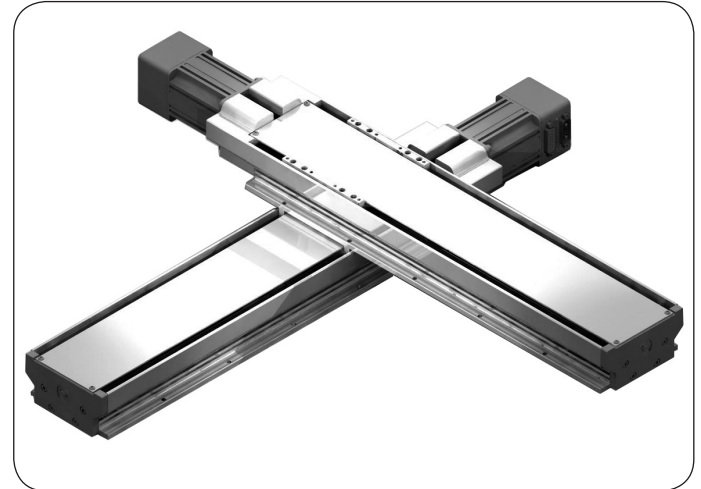

HLD60 with L70 2-Axis System

Direct mounting of an L70 actuator to an HLD actuator (except internal rollers) provides a compact secondary axis. This same setup can be in an X-Y or X-Z configuration.

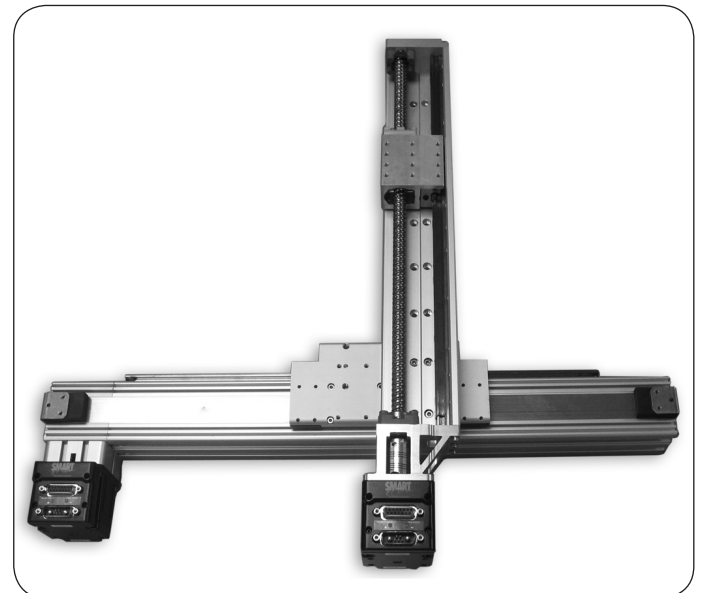

Note: We highly recommend all stand alone multi-axis systems be ordered with Combitronic CAN interface option via -C or -DN part number add-in

Considerations for Actuator Loading

Forces acting upon actuators consist of a combination of axial forces on any axis and a twisting force that may be applied due to offset loads.

Direct Forces placed on the Actuator

F.t. : Thrust Force operating in the direction of travel.

Mechanically Limiting Factor: For Lead Screw Actuators, this is typically the thrust bearings and/or lead nut.

For Harmonic Belt drives, the limiting factor is typically the belt. It may be based on shear strength of the belt teeth or on the actual tensile strength of the belt itself. In a welded belt, it would most likely be based on the weld strength of that belt.

F.st. : Side Thrust Force, acts upon the carriage from one side or the other.

The bearing support is typically the limiting factor. The choice of bearings and their orientation will greatly affect the maximum permissible force.

F.n. : Normal Force downward.

Similar to side force, the limit is based on the bearings and their orientation. It is very common to have a much higher normal downward force capacity than a side force capacity. Since Gravity typically plays a roll in Horizontal applications, most actuators are designed to deal with downward force effectively.

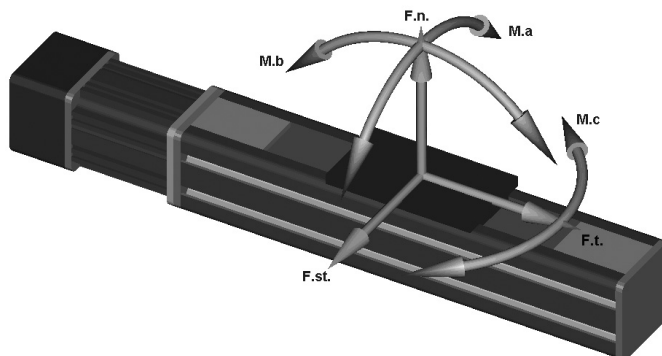

Moment Loading Forces:

This is the twisting force similar to a Moment arm force applying a torque to the supporting bearings.

To ensure long life of the actuator it is imperative to not exceed the Moment loading specifications.

In the above diagram, three Moment loads are depicted.

All three Moment loading forces may exist on a given application. It is important to remember that any offset load from the center surface of the actuator carriage will induce one or more of these Moment forces.

While accelerating, that Moment load may increase drastically.

For Example: Suppose in the above diagram, you place a load offset from the center of the carriage in upward direction. Any time the load is accelerated, the M.b. Moment loading will increase.

If the load is placed horizontally offset to one side or the other, dynamic motion will increase the M.c. component of Moment loading of that actuator.

The M.a. component is the only Moment loading that will not typically change with the dynamics of load motion. However, offset side loading is the greatest contributor to the M.a. component.

Understanding Thrust Curves

Actuator Thrust Curves are very similar to Servo Torque Curves, but relate to linear motion performance instead of shaft rotation performance. All thrust curves show continuous and peak performance based on the coupled system of Servo and Actuator together. The following examples show the 2 exceptions to the previous statement, where the actuators limitations are taken into account.

Note: The continuous thrust region is where the system should be operated, except for short hard accelerations required in your motion profile. Sustained Operation outside the continuous region will reduce the rated life on the actuator/integrated motor system. Please check the specifications of each actuator for limiting factors such as mechanical critical speed and thrust limits.

Limitation on Thrust Output Example

The curve to the right shows that there is a maximum amount of thrust the actuator can put out continuously and peak. That is why the curve abruptly flattens out (horizontal line) at speeds less than 150 mm/sec. This curve shows that the motor can provide more input torque than the actuator can handle at speeds less than 150 mm/sec.

Note: In this example, the maximum allowable thrust is limited to 550 N. Exceeding that could potentially damage the actuator even if the motor limits are not exceeded.

**HLD60 Single Rail/Internal Rollers
SM23165DT @ 48V, 2.5mm/rev**

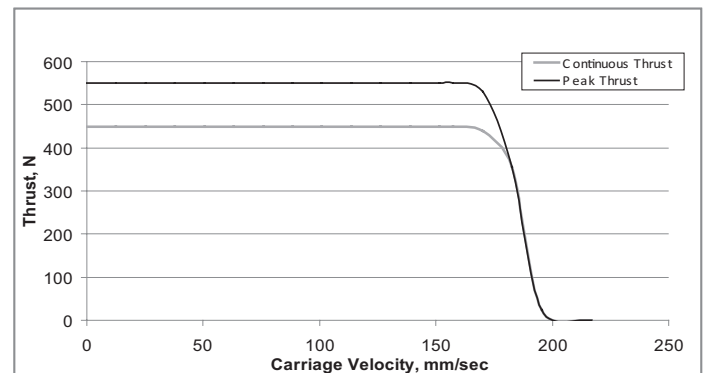

Limitation of Actuator's Speed Example

The curve to the right shows that at 500 mm/sec, the thrust abruptly goes to zero (the vertical line). This means that the actuator has a maximum carriage velocity of 500 mm/sec usually due to ball screw limitations.

Note: This speed limitation is mechanically based. It is possible to command a servo speed in excess of the Critical speed limits of the actuator. Doing so increases risk of damage and will shorten the life of the actuator.

VL-ST45 - SM2316D @ 48V, 6mm/rev lead ball screw

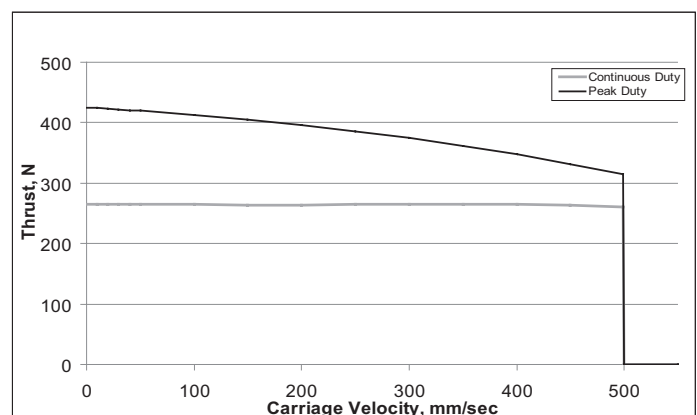

OVERVIEW
MOTOR SPECIFICATIONS
LINEAR SYSTEMS
CONNECTIVITY
PERIPHERALS
IP 65 MODELS & CONNECTIVITY
POWER SUPPLIES & SHUNTS
GEAR HEADS
SOFTWARE
APPENDIX

HLD60 Single Rail/Internal Rollers SM23165DT @ 48V, 2.5mm/rev

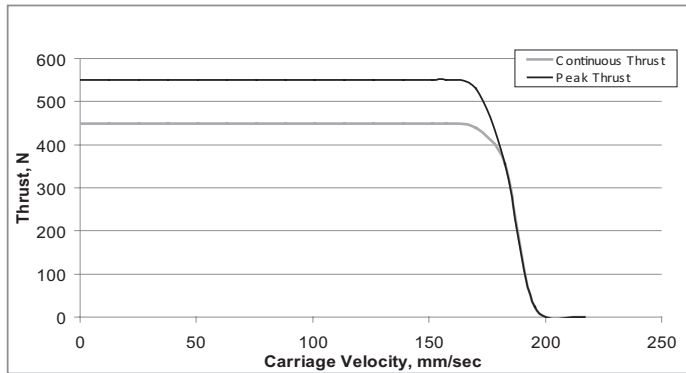

*450 N Dynamic Thrust Limit for Basic Service Life when operated at critical speed limits. **Please see pages 84-105 for lifetime information.

HLD60 Single Rail/Internal Rollers SM23165DT @ 48V, 5mm/rev

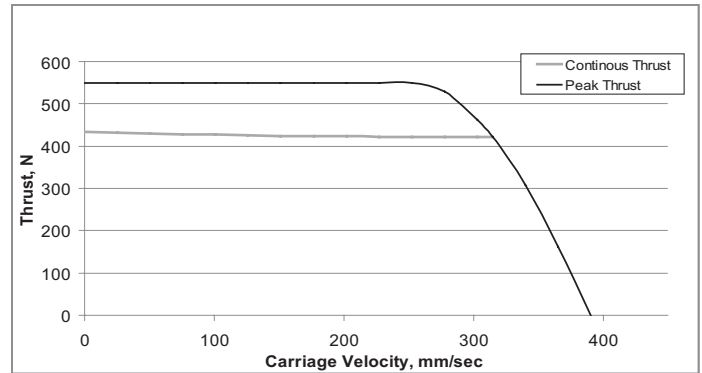

*420 N Dynamic Thrust Limit for Basic Service Life when operated at critical speed limits. **Please see pages 84-105 for lifetime information.

HLD60 Single Rail/Internal Rollers SM23165DT @ 42V, 2.5mm/rev

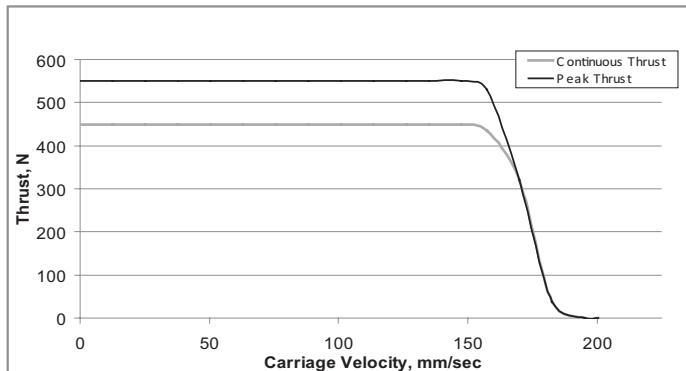

*450 N Dynamic Thrust Limit for Basic Service Life when operated at critical speed limits. **Please see pages 84-105 for lifetime information.

HLD60 Single Rail/Internal Rollers SM23165DT @ 42V, 5mm/rev

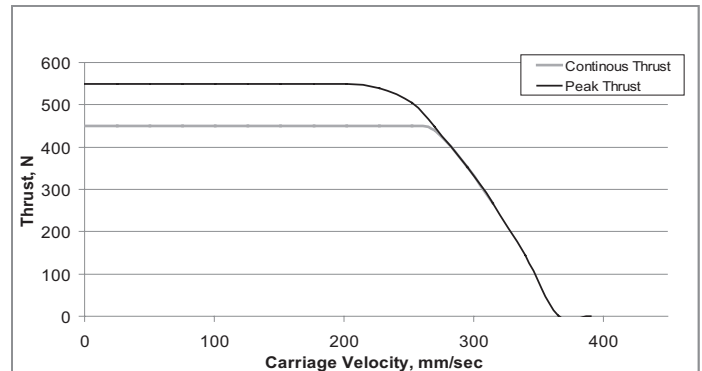

*420 N Dynamic Thrust Limit for Basic Service Life when operated at critical speed limits. **Please see pages 84-105 for lifetime information.

HLD60 Single Rail/Internal Rollers SM23165DT @ 24V, 2.5mm/rev

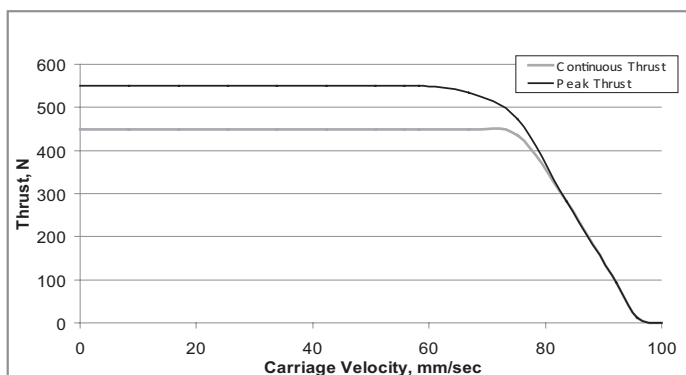

*450 N Dynamic Thrust Limit for Basic Service Life when operated at critical speed limits. **Please see pages 84-105 for lifetime information.

HLD60 Single Rail/Internal Rollers SM23165DT @ 24V, 5mm/rev

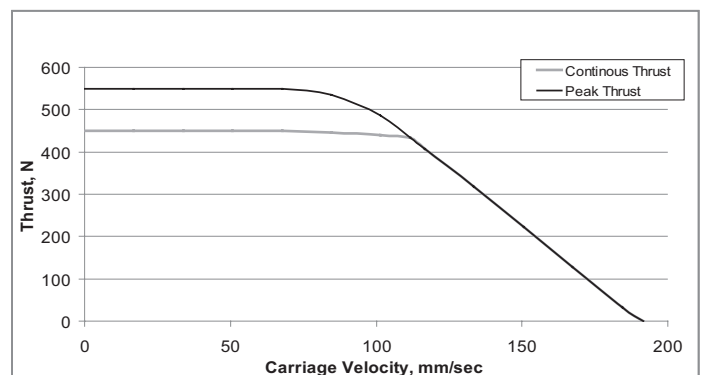

*420 N Dynamic Thrust Limit for Basic Service Life when operated at critical speed limits. **Please see pages 84-105 for lifetime information.

NOTE: Motor and Actuator specifications are subject to changes without notice. Consult Website and factory for latest data.

HLD60 Single Rail/Internal Rollers SM23165DT @ 48V, 10mm/rev

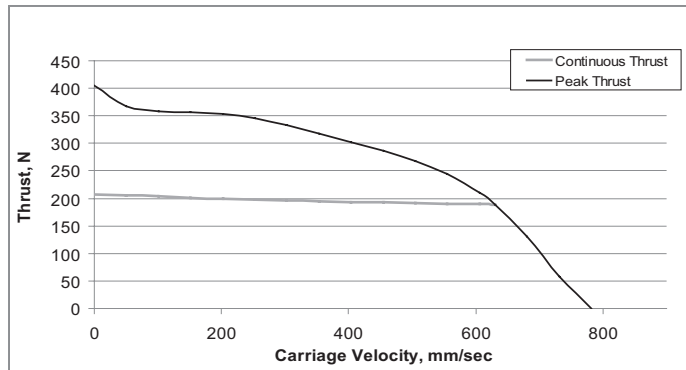

*185 N Dynamic Thrust Limit for Basic Service Life when operated at critical speed limits. **Please see pages 84-105 for lifetime information.

HLD60 Single Rail/Internal Rollers SM23165DT @ 48V, 12.5mm/rev

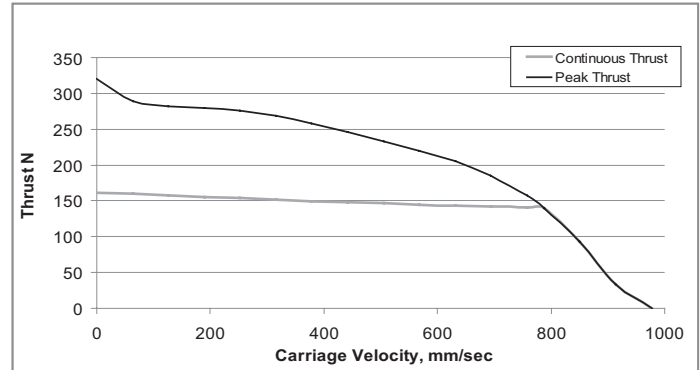

*135 N Dynamic Thrust Limit for Basic Service Life when operated at critical speed limits. **Please see pages 84-105 for lifetime information.

HLD60 Single Rail/Internal Rollers SM23165DT @ 42V, 10mm/rev

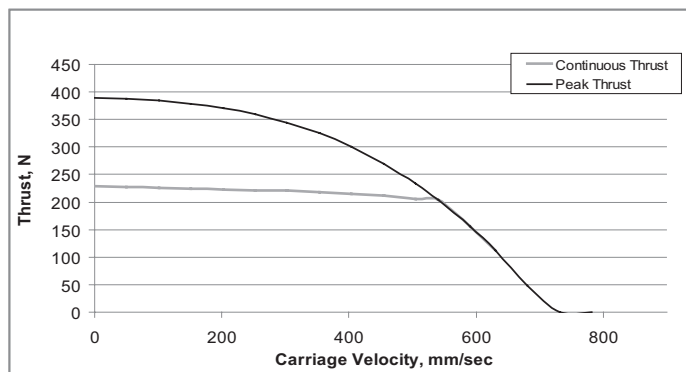

*185 N Dynamic Thrust Limit for Basic Service Life when operated at critical speed limits. **Please see pages 84-105 for lifetime information.

HLD60 Single Rail/Internal Rollers SM23165DT @ 42V, 12.5mm/rev

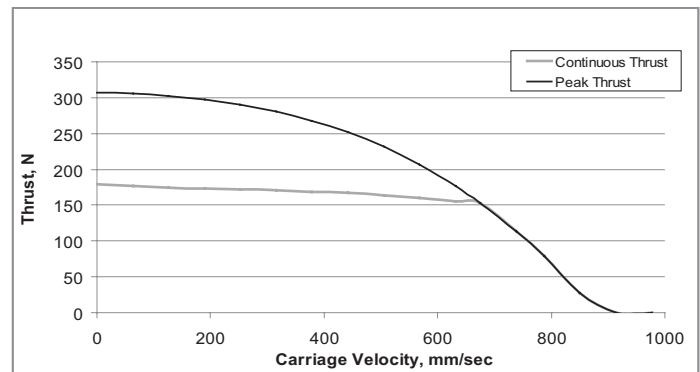

*135 N Dynamic Thrust Limit for Basic Service Life when operated at critical speed limits. **Please see pages 84-105 for lifetime information.

HLD60 Single Rail/Internal Rollers SM23165DT @ 24V, 10mm/rev

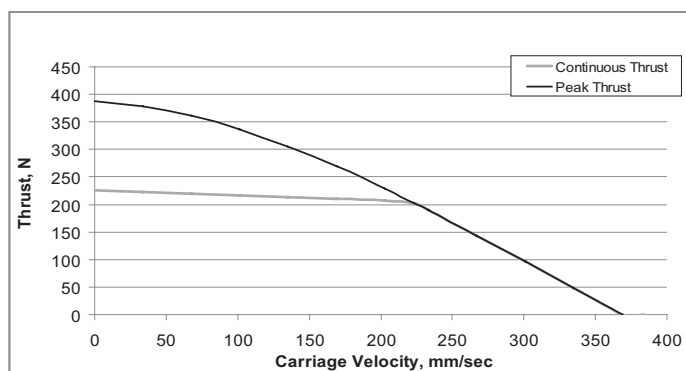

*185 N Dynamic Thrust Limit for Basic Service Life when operated at critical speed limits. **Please see pages 84-105 for lifetime information.

HLD60 Single Rail/Internal Rollers SM23165DT @ 24V, 12.5mm/rev

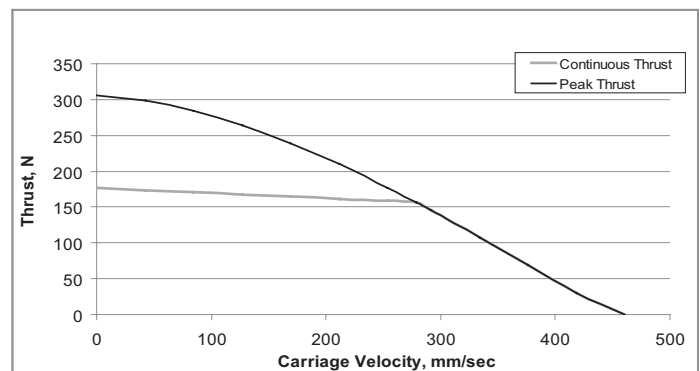

*135 N Dynamic Thrust Limit for Basic Service Life when operated at critical speed limits. **Please see pages 84-105 for lifetime information.

NOTE: Motor and Actuator specifications are subject to changes without notice. Consult Website and factory for latest data.

OVERVIEW
MOTOR SPECIFICATIONS
LINEAR SYSTEMS
CONNECTIVITY
PERIPHERALS
IP 65 MODELS & CONNECTIVITY
POWER SUPPLIES & SHUNTS
GEAR HEADS
SOFTWARE
APPENDIX

HLD60 Single Rail/Internal Rollers SM23165D @ 48V, 2.5mm/rev

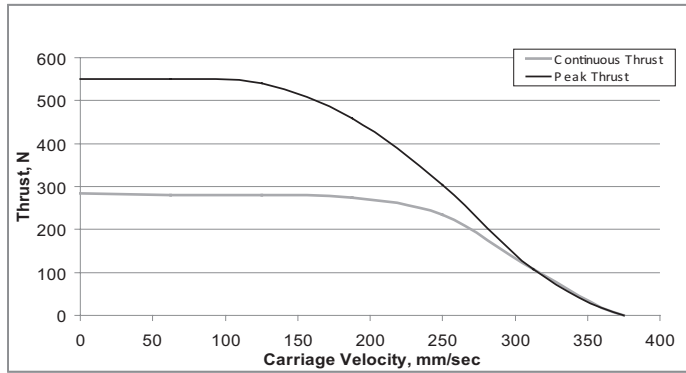

*284 N Dynamic Thrust Limit for Basic Service Life when operated at critical speed limits. **Please see pages 84-105 for lifetime information.

HLD60 Single Rail/Internal Rollers SM23165D @ 42V, 2.5mm/rev

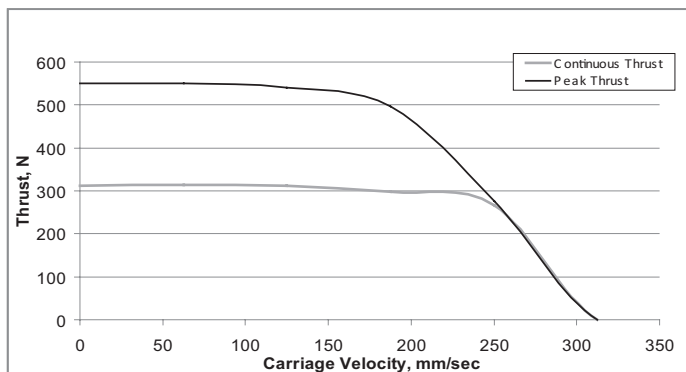

*284 N Dynamic Thrust Limit for Basic Service Life when operated at critical speed limits. **Please see pages 84-105 for lifetime information.

HLD60 Single Rail/Internal Rollers SM23165D @ 24V, 2.5mm/rev

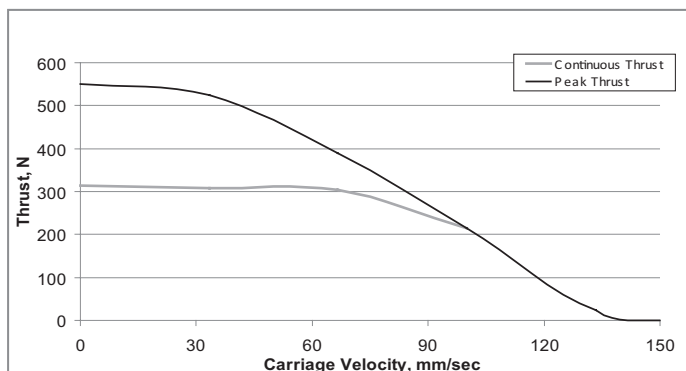

*284 N Dynamic Thrust Limit for Basic Service Life when operated at critical speed limits. **Please see pages 84-105 for lifetime information.

HLD60 Single Rail/Internal Rollers SM23165D @ 48V, 5mm/rev

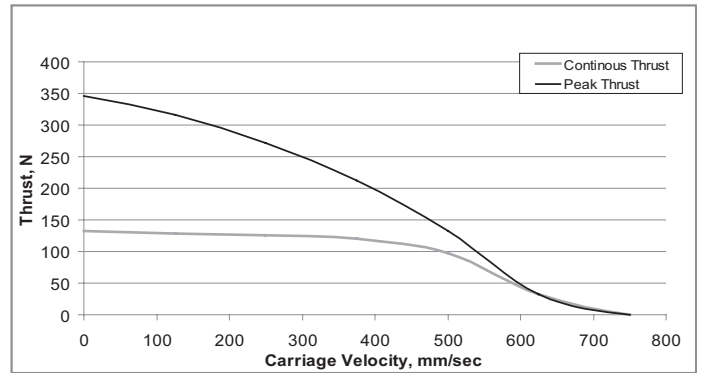

*132 N Dynamic Thrust Limit for Basic Service Life when operated at critical speed limits. **Please see pages 84-105 for lifetime information.

HLD60 Single Rail/Internal Rollers SM23165D @ 42V, 5mm/rev

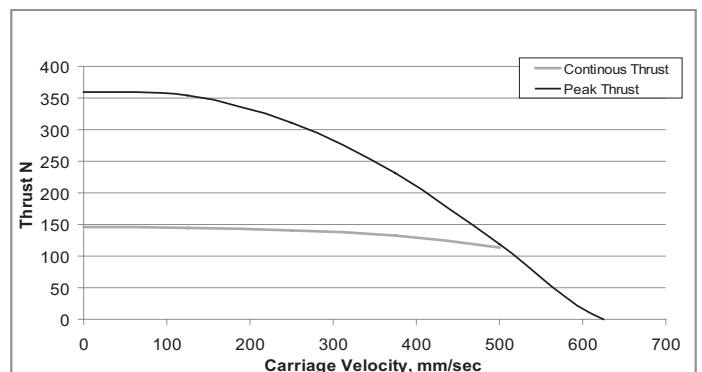

*132 N Dynamic Thrust Limit for Basic Service Life when operated at critical speed limits. **Please see pages 84-105 for lifetime information.

HLD60 Single Rail/Internal Rollers SM23165D @ 24V, 5mm/rev

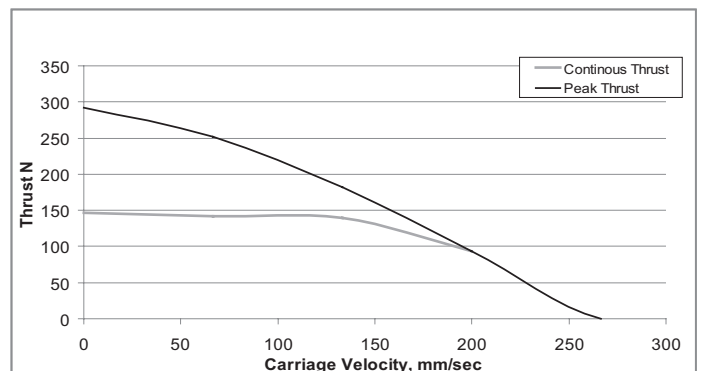

*132 N Dynamic Thrust Limit for Basic Service Life when operated at critical speed limits. **Please see pages 84-105 for lifetime information.

NOTE: Motor and Actuator specifications are subject to changes without notice. Consult Website and factory for latest data.

HLD60 Single Rail/Internal Rollers SM23165D @ 48V, 10mm/rev

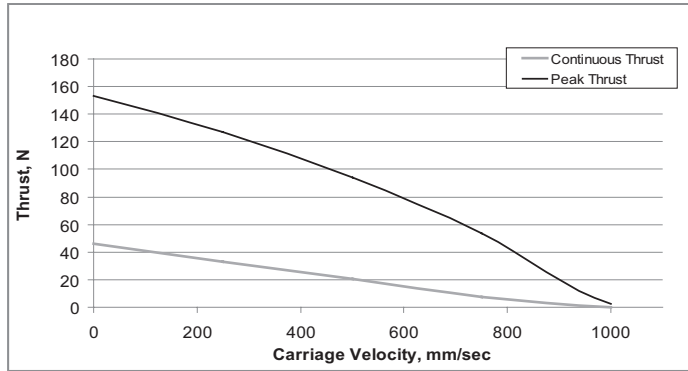

*45 N Dynamic Thrust Limit for Basic Service Life when operated at critical speed limits. **Please see pages 84-105 for lifetime information.

HLD60 Single Rail/Internal Rollers SM23165D @ 42V, 10mm/rev

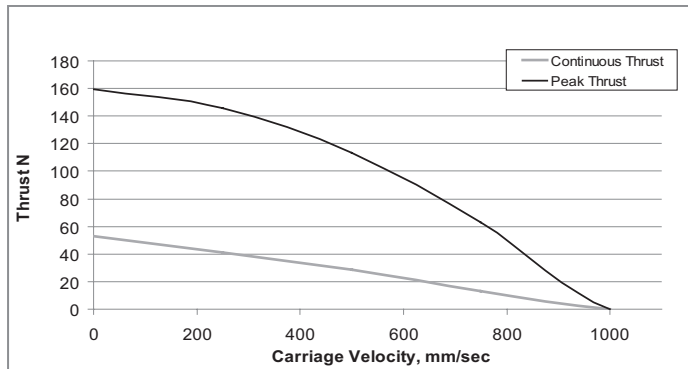

*45 N Dynamic Thrust Limit for Basic Service Life when operated at critical speed limits. **Please see pages 84-105 for lifetime information.

HLD60 Single Rail/Internal Rollers SM23165D @ 24V, 10mm/rev

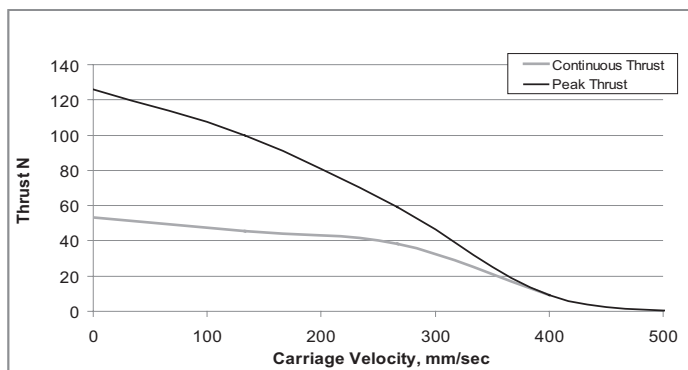

*45 N Dynamic Thrust Limit for Basic Service Life when operated at critical speed limits. **Please see pages 84-105 for lifetime information.

NOTE: Motor and Actuator specifications are subject to changes without notice. Consult Website and factory for latest data.

OVERVIEW
MOTOR SPECIFICATIONS
LINEAR SYSTEMS
CONNECTIVITY
PERIPHERALS
IP 65 MODELS & CONNECTIVITY
POWER SUPPLIES & SHUNTS
GEAR HEADS
SOFTWARE
APPENDIX

HLD60 Twin Rails - SM23165DT @ 48V, 2.5mm/rev

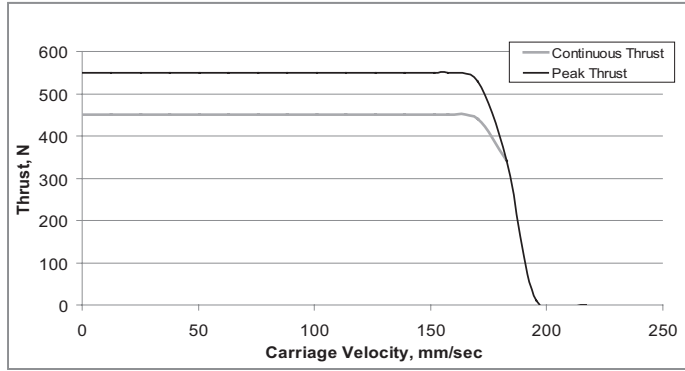

*450 N Dynamic Thrust Limit for Basic Service Life when operated at critical speed limits. **Please see page 84-105 for lifetime information.

HLD60 Twin Rails - SM23165DT @ 48V, 5mm/rev

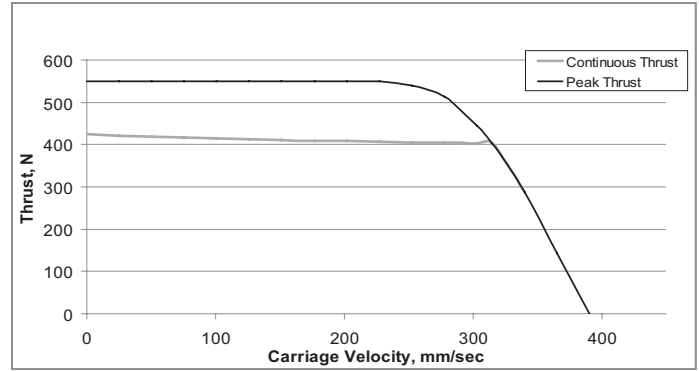

*400 N Dynamic Thrust Limit for Basic Service Life when operated at critical speed limits. **Please see page 84-105 for lifetime information.

HLD60 Twin Rails - SM23165DT @ 42V, 2.5mm/rev

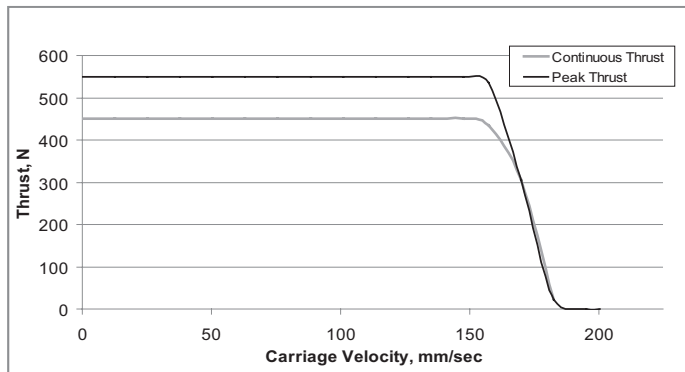

*450 N Dynamic Thrust Limit for Basic Service Life when operated at critical speed limits. **Please see page 84-105 for lifetime information.

HLD60 Twin Rails - SM23165DT @ 42V, 5mm/rev

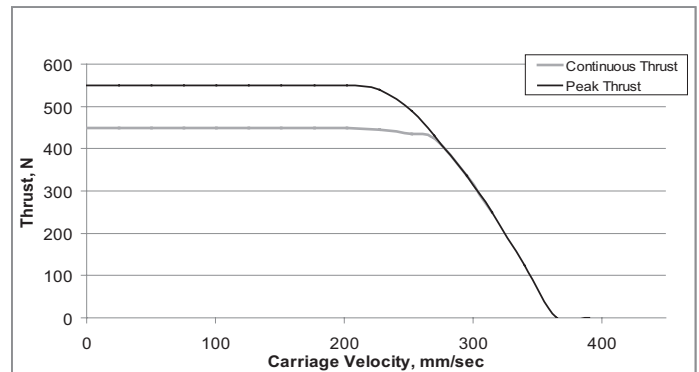

*400 N Dynamic Thrust Limit for Basic Service Life when operated at critical speed limits. **Please see page 84-105 for lifetime information.

HLD60 Twin Rails - SM23165DT @ 24V, 2.5mm/rev

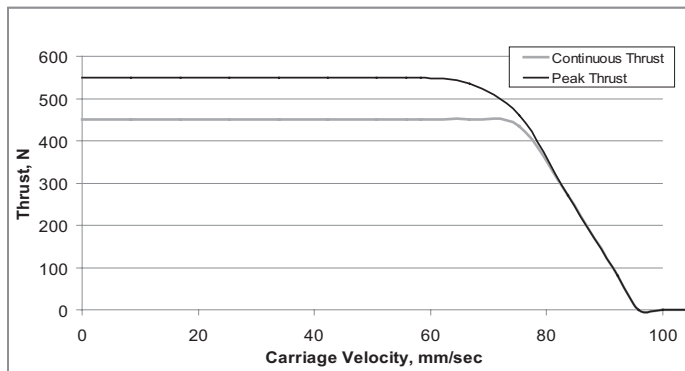

*450 N Dynamic Thrust Limit for Basic Service Life when operated at critical speed limits. **Please see page 84-105 for lifetime information.

HLD60 Twin Rails - SM23165DT @ 24V, 5mm/rev

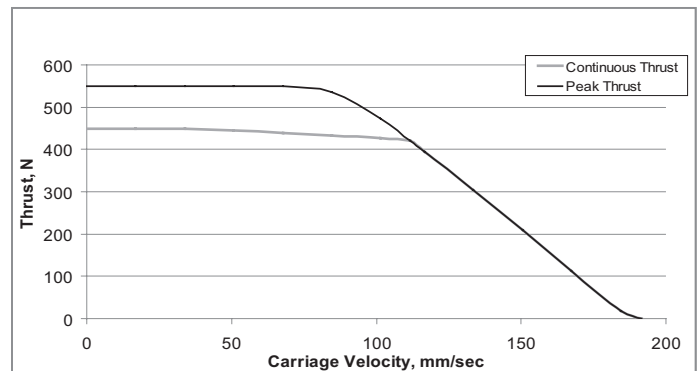

*400 N Dynamic Thrust Limit for Basic Service Life when operated at critical speed limits. **Please see page 84-105 for lifetime information.

NOTE: Motor and Actuator specifications are subject to changes without notice. Consult Website and factory for latest data.

HLD60 Twin Rails - SM23165DT @ 48V, 10mm/rev

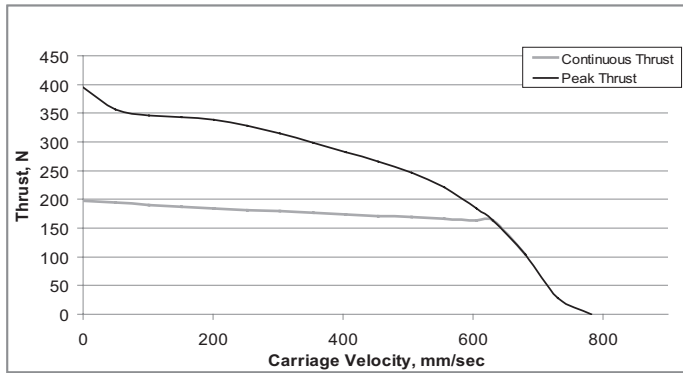

*160 N Dynamic Thrust Limit for Basic Service Life when operated at critical speed limits. **Please see page 84-105 for lifetime information.

HLD60 Twin Rails - SM23165DT @ 48V, 12.5mm/rev

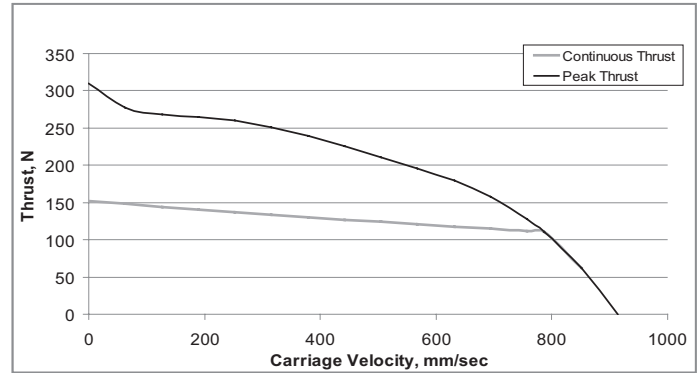

*105 N Dynamic Thrust Limit for Basic Service Life when operated at critical speed limits. **Please see page 84-105 for lifetime information.

HLD60 Twin Rails - SM23165DT @ 42V, 10mm/rev

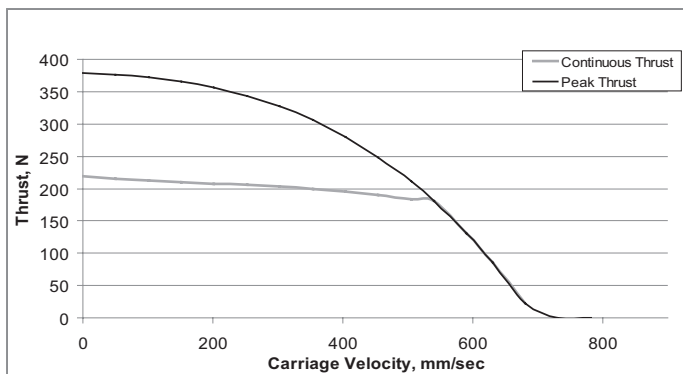

*160 N Dynamic Thrust Limit for Basic Service Life when operated at critical speed limits. **Please see page 84-105 for lifetime information.

HLD60 Twin Rails - SM23165DT @ 42V, 12.5mm/rev

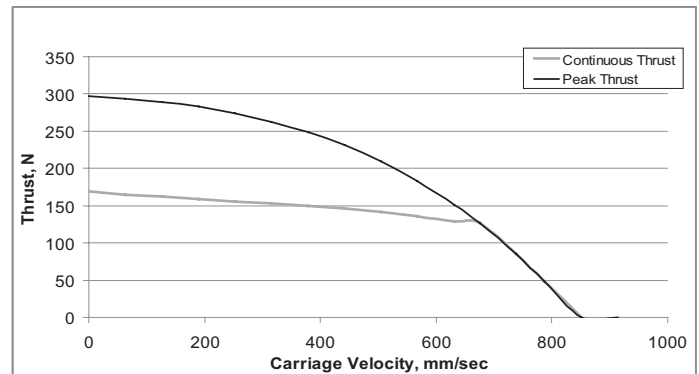

*105 N Dynamic Thrust Limit for Basic Service Life when operated at critical speed limits. **Please see page 84-105 for lifetime information.

HLD60 Twin Rails - SM23165DT @ 24V, 10mm/rev

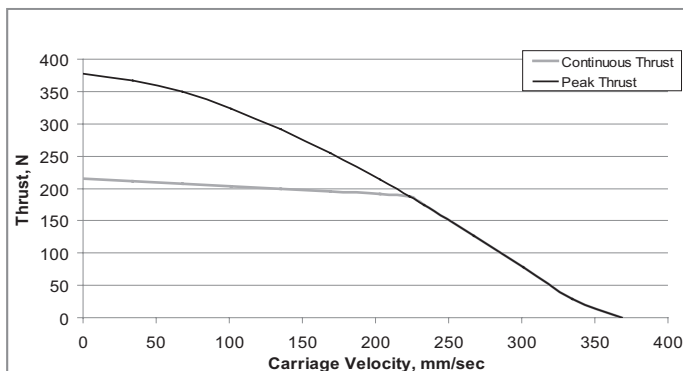

*160 N Dynamic Thrust Limit for Basic Service Life when operated at critical speed limits. **Please see page 84-105 for lifetime information.

HLD60 Twin Rails - SM23165DT @ 24V, 12.5mm/rev

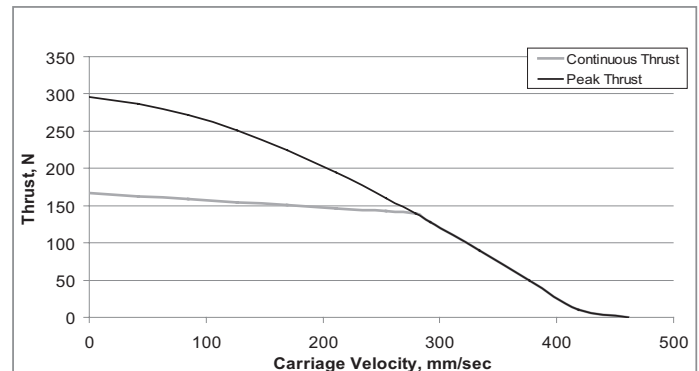

*105 N Dynamic Thrust Limit for Basic Service Life when operated at critical speed limits. **Please see page 84-105 for lifetime information.

NOTE: Motor and Actuator specifications are subject to changes without notice. Consult Website and factory for latest data.

OVERVIEW
MOTOR SPECIFICATIONS
LINEAR SYSTEMS
CONNECTIVITY
PERIPHERALS
IP 65 MODELS & CONNECTIVITY
POWER SUPPLIES & SHUNTS
GEAR HEADS
SOFTWARE
APPENDIX

HLD60 Twin Rails - SM23165D @ 48V, 2.5mm/rev

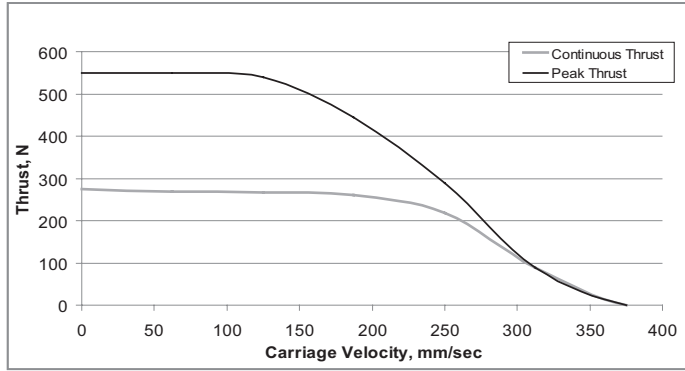

*274 N Dynamic Thrust Limit for Basic Service Life when operated at critical speed limits. **Please see page 84-105 for lifetime information.

HLD60 Twin Rails - SM23165D @ 48V, 5mm/rev

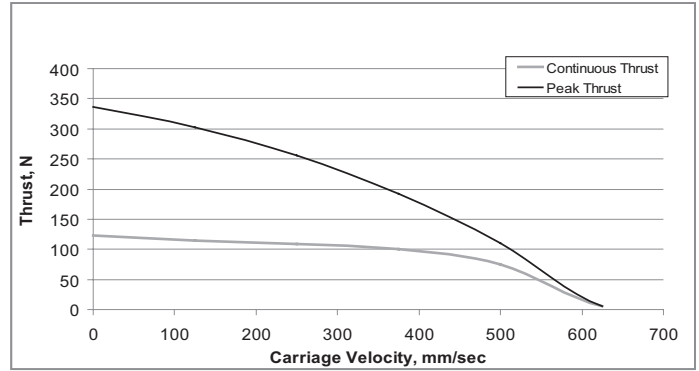

*122 N Dynamic Thrust Limit for Basic Service Life when operated at critical speed limits. **Please see page 84-105 for lifetime information.

HLD60 Twin Rails - SM23165D @ 42V, 2.5mm/rev

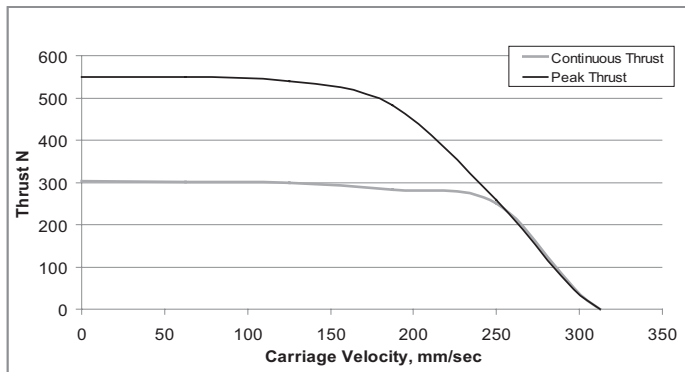

*274 N Dynamic Thrust Limit for Basic Service Life when operated at critical speed limits. **Please see page 84-105 for lifetime information.

HLD60 Twin Rails - SM23165D @ 42V, 5mm/rev

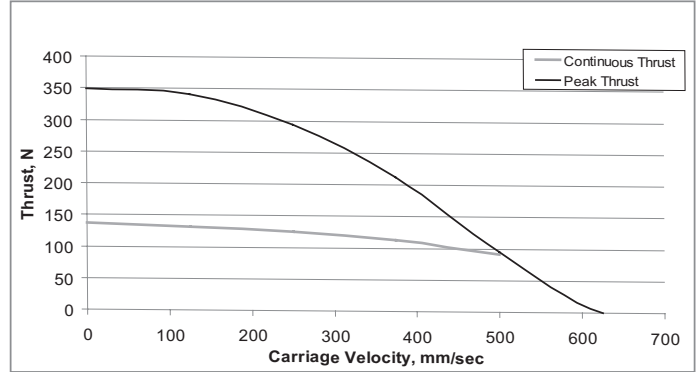

*122 N Dynamic Thrust Limit for Basic Service Life when operated at critical speed limits. **Please see page 84-105 for lifetime information.

HLD60 Twin Rails - SM23165D @ 24V, 2.5mm/rev

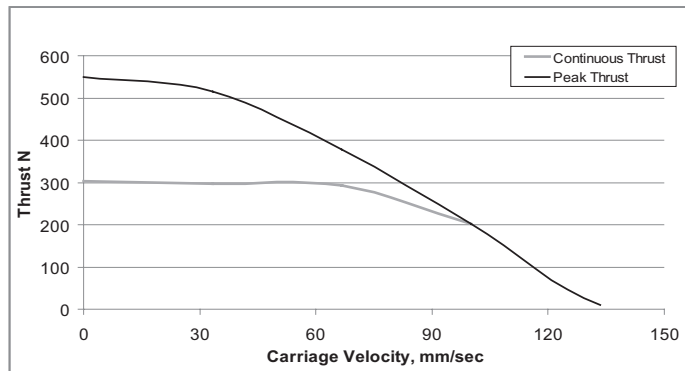

*274 N Dynamic Thrust Limit for Basic Service Life when operated at critical speed limits. **Please see page 84-105 for lifetime information.

HLD60 Twin Rails - SM23165D @ 24V, 5mm/rev

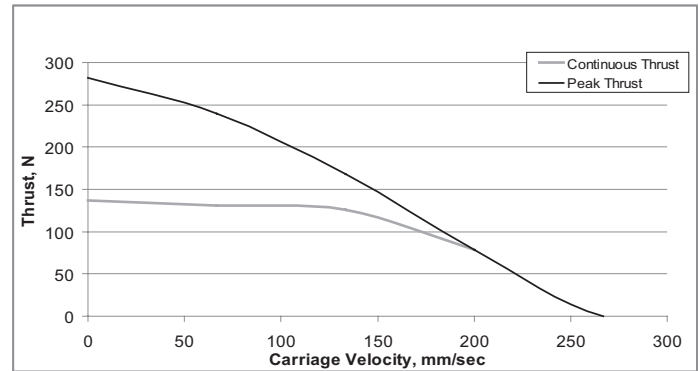

*122 N Dynamic Thrust Limit for Basic Service Life when operated at critical speed limits. **Please see page 84-105 for lifetime information.

NOTE: Motor and Actuator specifications are subject to changes without notice. Consult Website and factory for latest data.

HLD60 Twin Rails - SM23165D @ 48V, 10mm/rev

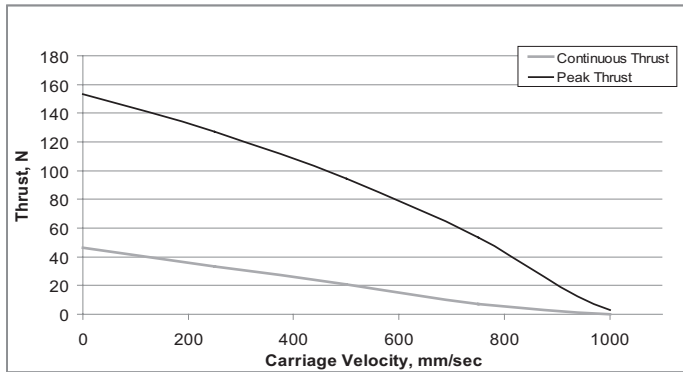

*45 N Dynamic Thrust Limit for Basic Service Life when operated at critical speed limits. **Please see page 84-105 for lifetime information.

HLD60 Twin Rails - SM23165D @ 42V, 10mm/rev

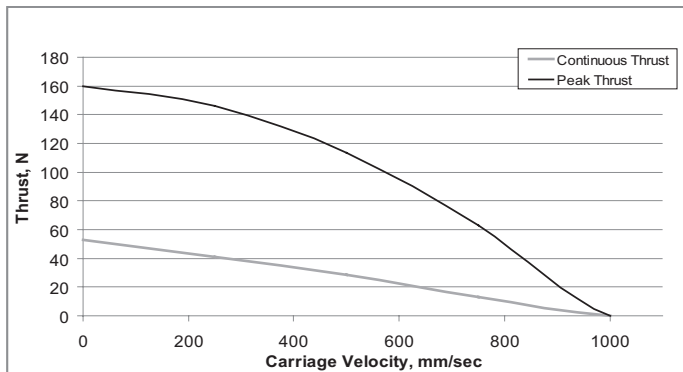

*45 N Dynamic Thrust Limit for Basic Service Life when operated at critical speed limits. **Please see page 84-105 for lifetime information.

HLD60 Twin Rails - SM23165D @ 24V, 10mm/rev

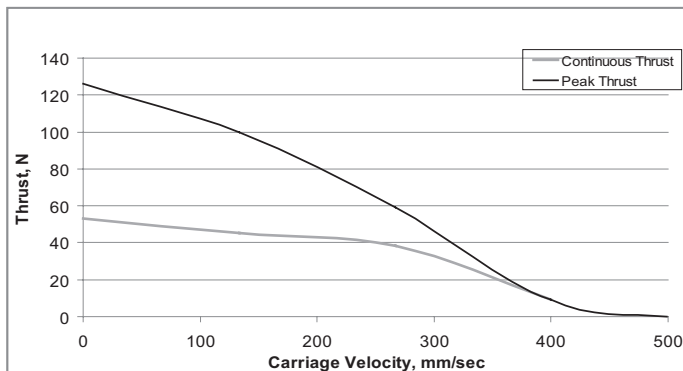

*45 N Dynamic Thrust Limit for Basic Service Life when operated at critical speed limits. **Please see page 84-105 for lifetime information.

NOTE: Motor and Actuator specifications are subject to changes without notice. Consult Website and factory for latest data.

OVERVIEW
MOTOR SPECIFICATIONS
LINEAR SYSTEMS
CONNECTIVITY
PERIPHERALS
IP 65 MODELS & CONNECTIVITY
POWER SUPPLIES & SHUNTS
GEAR HEADS
SOFTWARE
APPENDIX

L70/XL100 - SM23165DT @ 48V, 5mm/rev lead ball screw

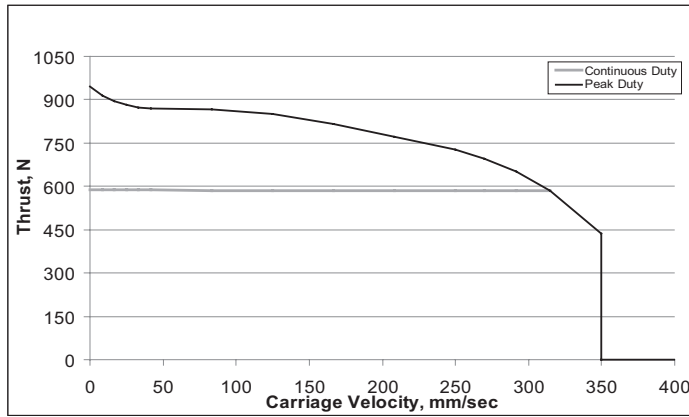

*200 N Dynamic Thrust Limit for Basic Service Life when operated at critical speed limits. **Please see pages 84-105 for lifetime information.

L70/XL100 - SM23165DT @ 48V, 10mm/rev lead ball screw

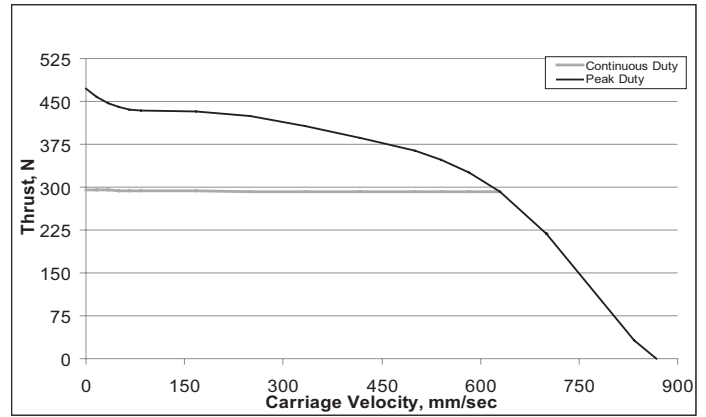

*200 N Dynamic Thrust Limit for Basic Service Life when operated at critical speed limits. **Please see pages 84-105 for lifetime information.

L70/XL100 - SM23165DT @ 42V, 5mm/rev lead ball screw

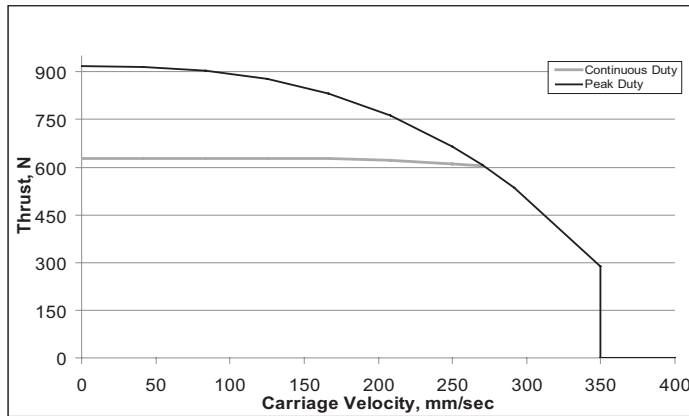

*200 N Dynamic Thrust Limit for Basic Service Life when operated at critical speed limits. **Please see pages 84-105 for lifetime information.

L70/XL100 - SM23165DT @ 42V, 10mm/rev lead ball screw

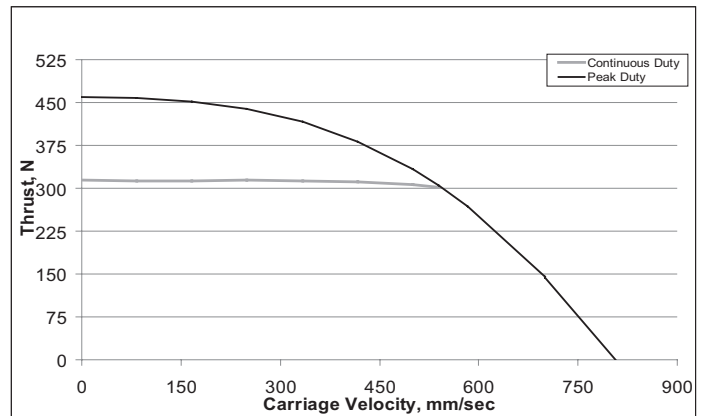

*200 N Dynamic Thrust Limit for Basic Service Life when operated at critical speed limits. **Please see pages 84-105 for lifetime information.

L70/XL100 - SM23165DT @ 24V, 5mm/rev lead ball screw

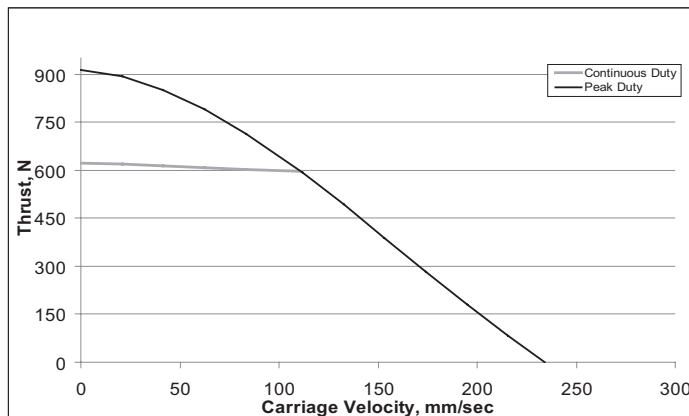

*200 N Dynamic Thrust Limit for Basic Service Life when operated at critical speed limits. **Please see pages 84-105 for lifetime information.

L70/XL100 - SM23165DT @ 24V, 10mm/rev lead ball screw

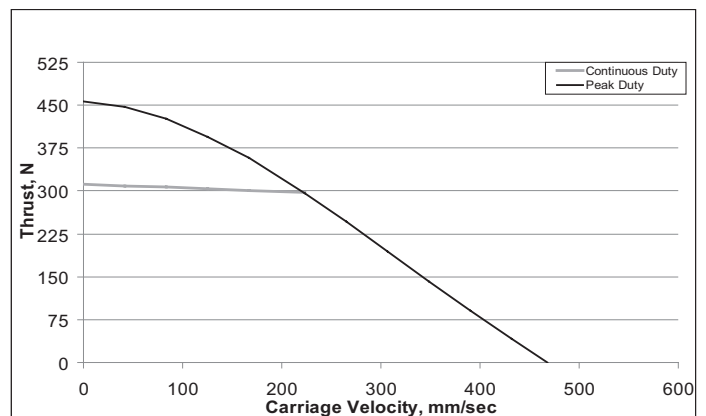

*200 N Dynamic Thrust Limit for Basic Service Life when operated at critical speed limits. **Please see pages 84-105 for lifetime information.

NOTE: Motor and Actuator specifications are subject to changes without notice. Consult Website and factory for latest data.

L70/XL100 - SM23165D @ 48V, 5mm/rev lead ball screw

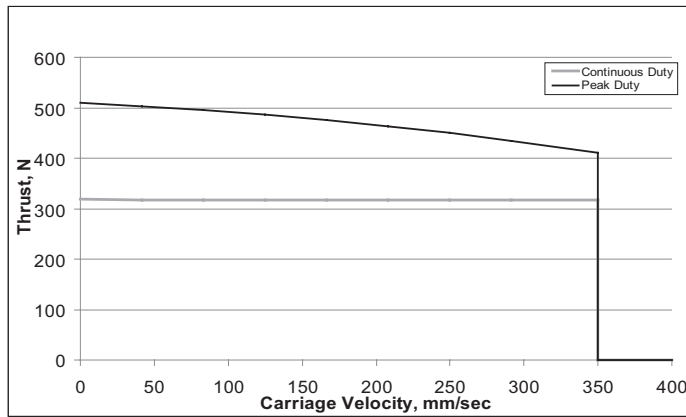

*200 N Dynamic Thrust Limit for Basic Service Life when operated at critical speed limits. **Please see pages 84-105 for lifetime information.

L70/XL100 - SM23165D @ 48V, 10mm/rev lead ball screw

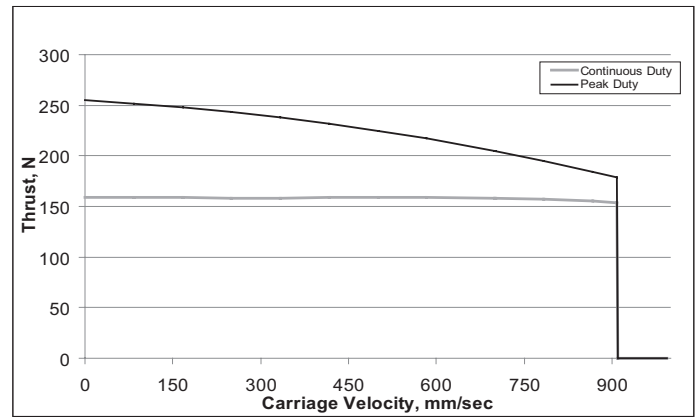

*200 N Dynamic Thrust Limit for Basic Service Life when operated at critical speed limits. **Please see pages 84-105 for lifetime information.

L70/XL100 - SM23165D @ 42V, 5mm/rev lead ball screw

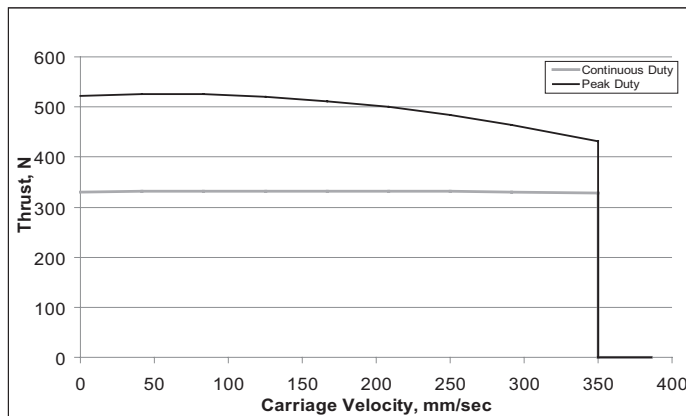

*200 N Dynamic Thrust Limit for Basic Service Life when operated at critical speed limits. **Please see pages 84-105 for lifetime information.

L70/XL100 - SM23165D @ 42V, 10mm/rev lead ball screw

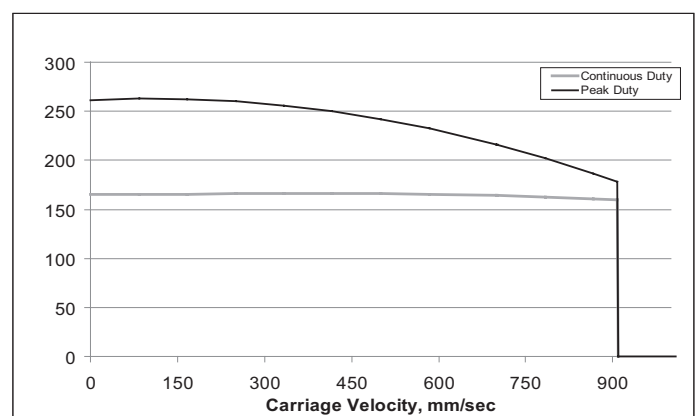

*200 N Dynamic Thrust Limit for Basic Service Life when operated at critical speed limits. **Please see pages 84-105 for lifetime information.

L70/XL100 - SM23165D @ 24V, 5mm/rev lead ball screw

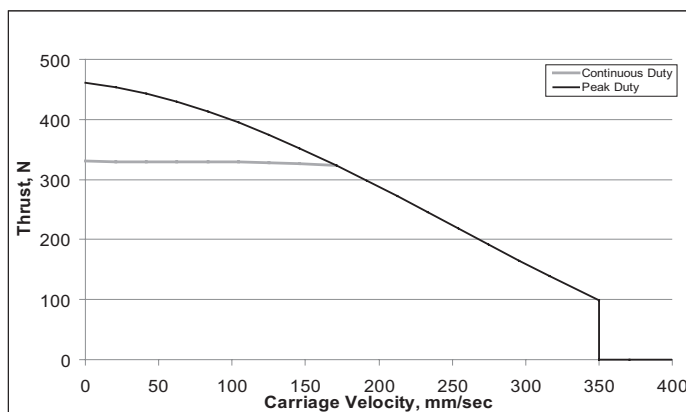

*200 N Dynamic Thrust Limit for Basic Service Life when operated at critical speed limits. **Please see pages 84-105 for lifetime information.

L70/XL100 - SM23165D @ 24V, 10mm/rev lead ball screw

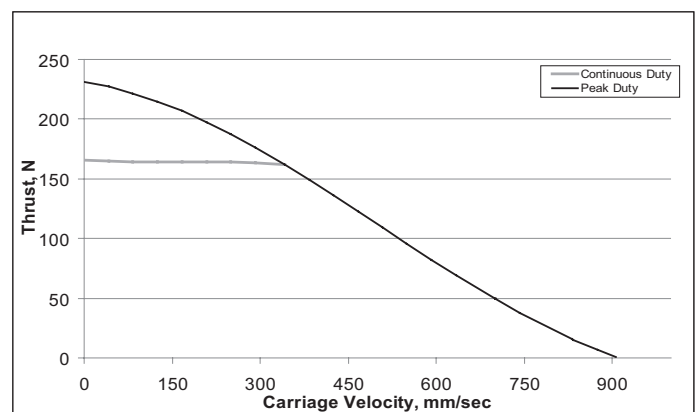

*200 N Dynamic Thrust Limit for Basic Service Life when operated at critical speed limits. **Please see pages 84-105 for lifetime information.

NOTE: Motor and Actuator specifications are subject to changes without notice. Consult Website and factory for latest data.

OVERVIEW
MOTOR SPECIFICATIONS
LINEAR SYSTEMS
CONNECTIVITY
PERIPHERALS
IP 65 MODELS & CONNECTIVITY
POWER SUPPLIES & SHUNTS
GEAR HEADS
SOFTWARE
APPENDIX

VL-CT series - SM23165DT @ 48V, Direct Drive & 1:1 Pulley Offset

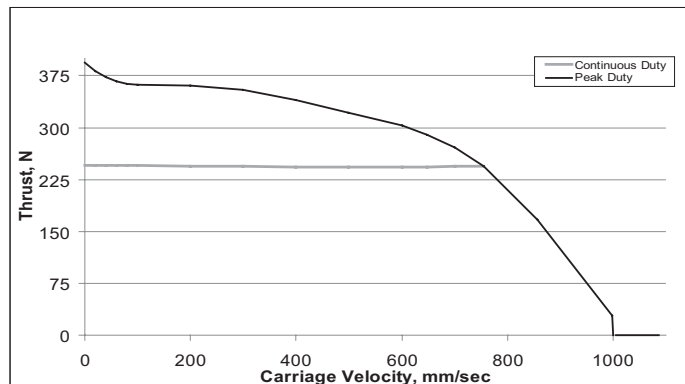

*220 N (VL-CT55) or 55 N (VL-CT35/45) Dynamic Thrust Limit for Basic Service Life when operated at critical speed limits

VL-CT series - SM23165D @ 48V, Direct Drive & 1:1 Pulley Offset

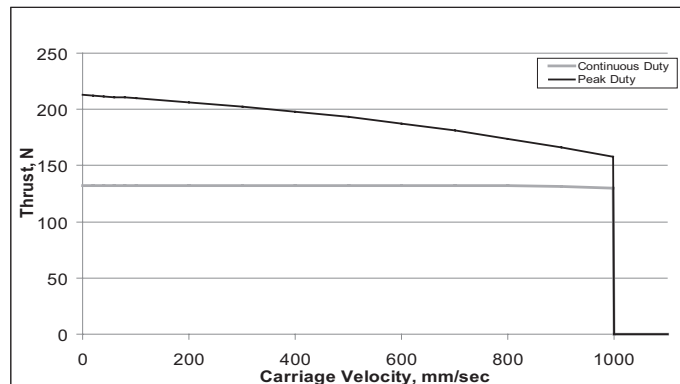

*132 N (VL-CT55) or 55 N (VL-CT35/45) Dynamic Thrust Limit for Basic Service Life when operated at critical speed limits

VL-CT series - SM23165DT @ 42V, Direct Drive & 1:1 Pulley Offset

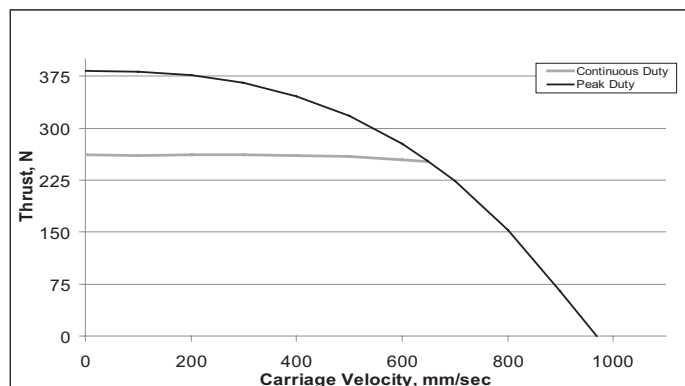

*220 N (VL-CT55) or 55 N (VL-CT35/45) Dynamic Thrust Limit for Basic Service Life when operated at critical speed limits

VL-CT series - SM23165D @ 42V, Direct Drive & 1:1 Pulley Offset

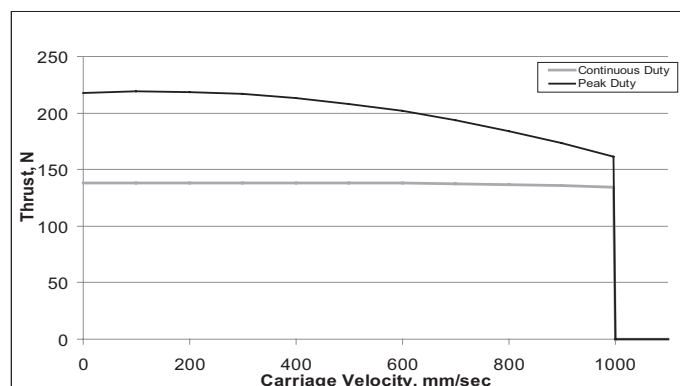

*132 N (VL-CT55) or 55 N (VL-CT35/45) Dynamic Thrust Limit for Basic Service Life when operated at critical speed limits

VL-CT series - SM23165DT @ 24V, Direct Drive & 1:1 Pulley Offset

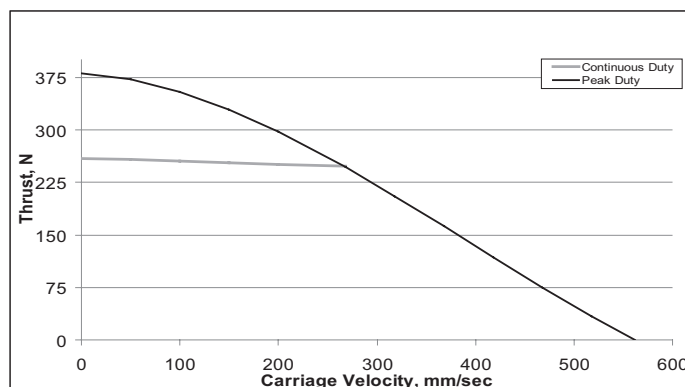

*220 N (VL-CT55) or 55 N (VL-CT35/45) Dynamic Thrust Limit for Basic Service Life when operated at critical speed limits

VL-CT series - SM23165D @ 24V, Direct Drive & 1:1 Pulley Offset

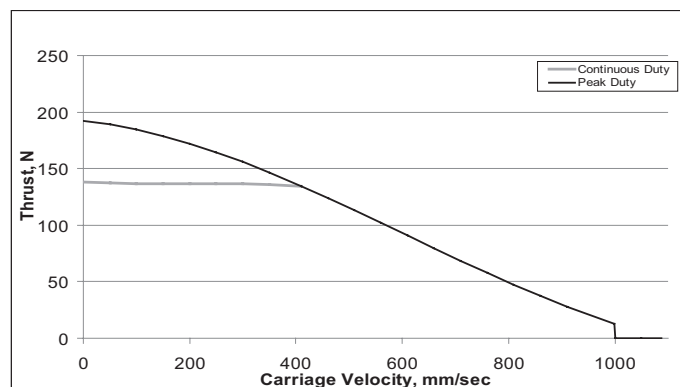

*132 N (VL-CT55) or 55 N (VL-CT35/45) Dynamic Thrust Limit for Basic Service Life when operated at critical speed limits

NOTE: Motor and Actuator specifications are subject to changes without notice. Consult Website and factory for latest data.

VL-CT35/45 - SM23165DT @ 48V, 2:1 pulley offset

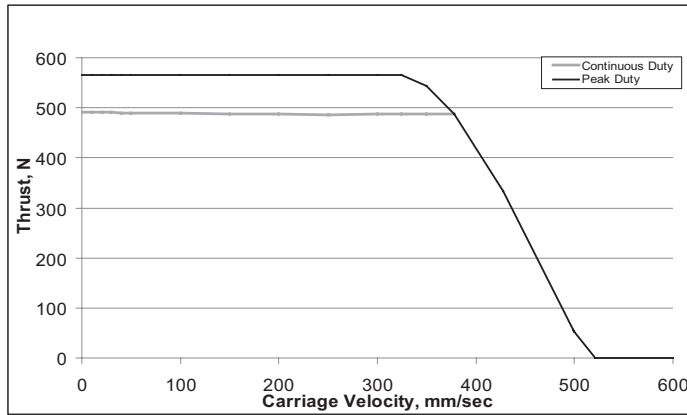

**Please see pages 84-105 for lifetime, moment loading and ball screw critical speed limitations for the VL Series actuators.

VL-CT series - SM23165D @ 48V, 2:1 pulley offset

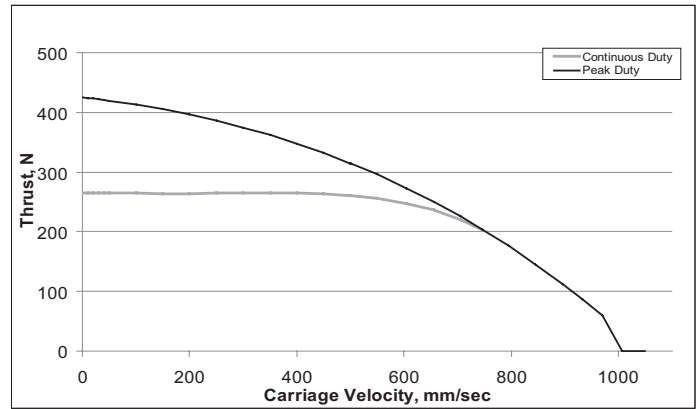

**Please see pages 84-105 for lifetime, moment loading and ball screw critical speed limitations for the VL Series actuators.

VL-CT35/45 - SM23165DT @ 42V, 2:1 pulley offset

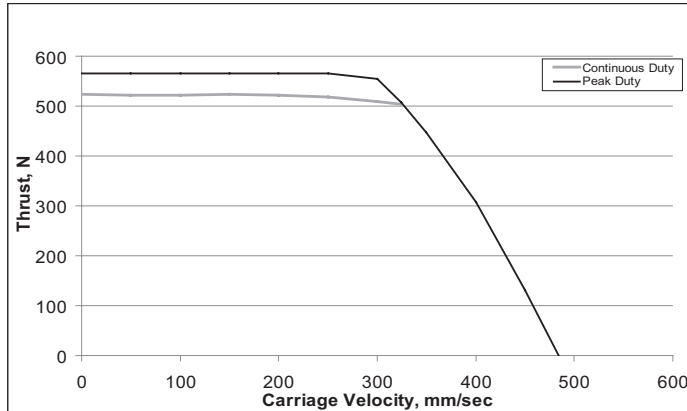

**Please see pages 84-105 for lifetime, moment loading and ball screw critical speed limitations for the VL Series actuators.

VL-CT series - SM23165D @ 42V, 2:1 pulley offset

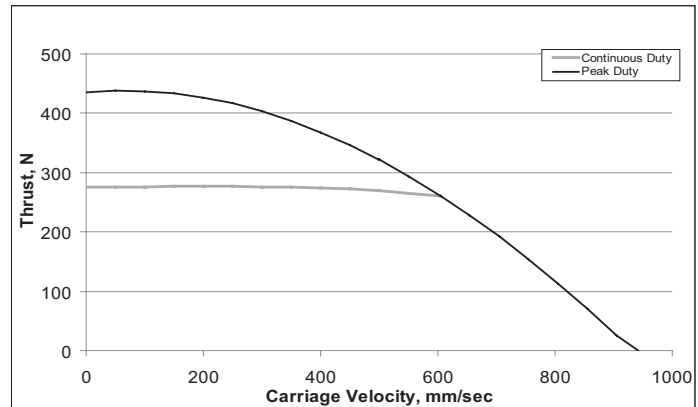

**Please see pages 84-105 for lifetime, moment loading and ball screw critical speed limitations for the VL Series actuators.

VL-CT35/45 - SM23165DT @ 24V, 2:1 pulley offset

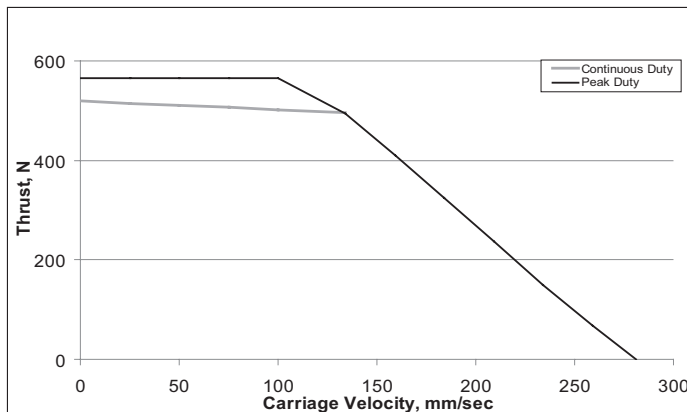

**Please see pages 84-105 for lifetime, moment loading and ball screw critical speed limitations for the VL Series actuators.

VL-CT series - SM23165D @ 24V, 2:1 pulley offset

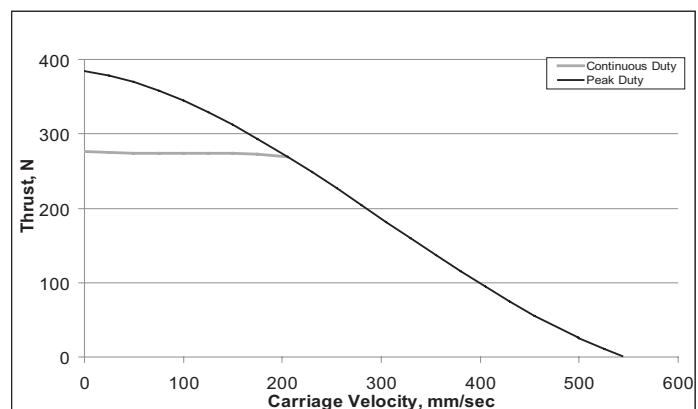

**Please see pages 84-105 for lifetime, moment loading and ball screw critical speed limitations for the VL Series actuators.

NOTE: Motor and Actuator specifications are subject to changes without notice. Consult Website and factory for latest data.

OVERVIEW
MOTOR SPECIFICATIONS
LINEAR SYSTEMS
CONNECTIVITY
PERIPHERALS
IP 65 MODELS & CONNECTIVITY
POWER SUPPLIES & SHUNTS
GEAR HEADS
SOFTWARE
APPENDIX

VL-CT55 - SM2316DT @ 48V, 3:1 pulley offset

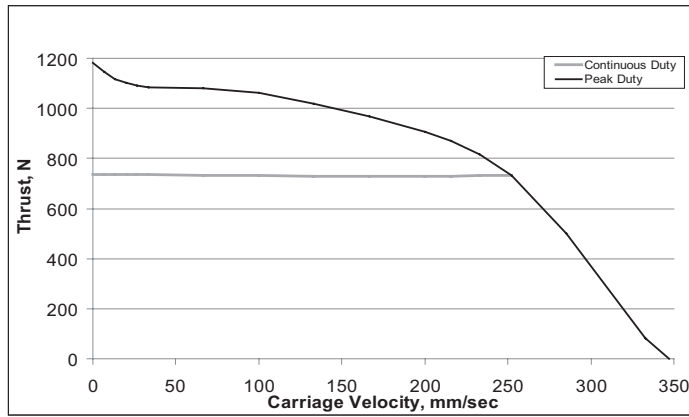

*15,000 hours of lifetime if operating at an average speed of 200 mm/s at or below a 28 kg load.

**Please see pages 84-105 for lifetime, moment loading and ball screw critical speed limitations for the VL Series actuators.

VL-CT55 - SM2316DT @ 42V, 3:1 pulley offset

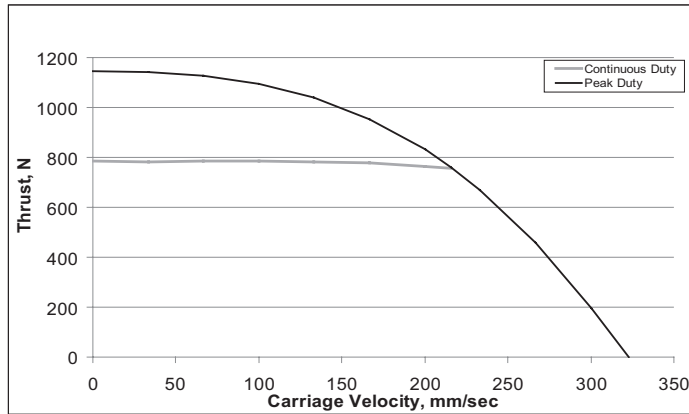

*15,000 hours of lifetime if operating at an average speed of 200 mm/s at or below a 28 kg load.

**Please see pages 84-105 for lifetime, moment loading and ball screw critical speed limitations for the VL Series actuators.

VL-CT55 - SM2316DT @ 24V, 3:1 pulley offset

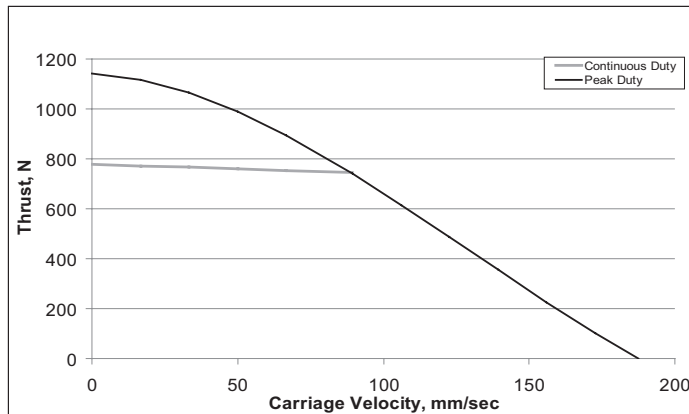

*15,000 hours of lifetime if operating at an average speed of 100 mm/s at or below a 35 kg load.

**Please see pages 84-105 for lifetime, moment loading and ball screw critical speed limitations for the VL Series actuators.

NOTE: Motor and Actuator specifications are subject to changes without notice. Consult Website and factory for latest data.

VL-CT35/45 - SM2316D @ 48V, 3:1 pulley offset

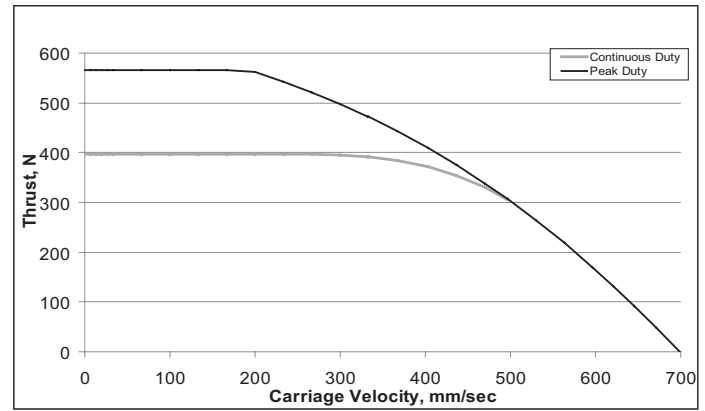

*Please see pages 84-105 for lifetime, moment loading and ball screw critical speed limitations for the VL Series actuators.

VL-CT35/45 - SM2316D @ 42V, 3:1 pulley offset

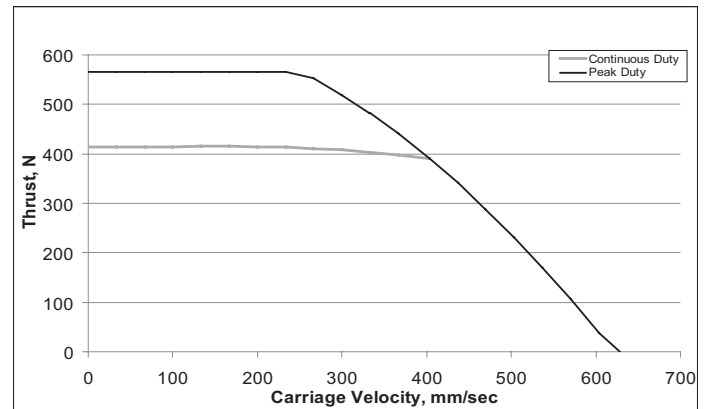

*Please see pages 84-105 for lifetime, moment loading and ball screw critical speed limitations for the VL Series actuators.

VL-CT35/45 - SM2316D @ 24V, 3:1 pulley offset

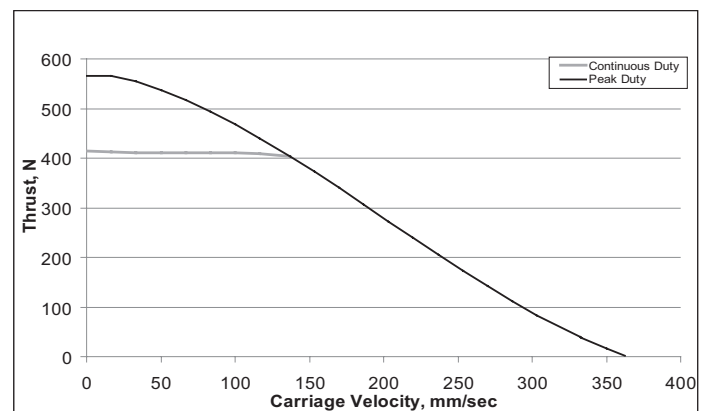

*Please see pages 84-105 for lifetime, moment loading and ball screw critical speed limitations for the VL Series actuators.

VL-ST45 - SM23165D @ 48V, 6mm/rev lead ball screw

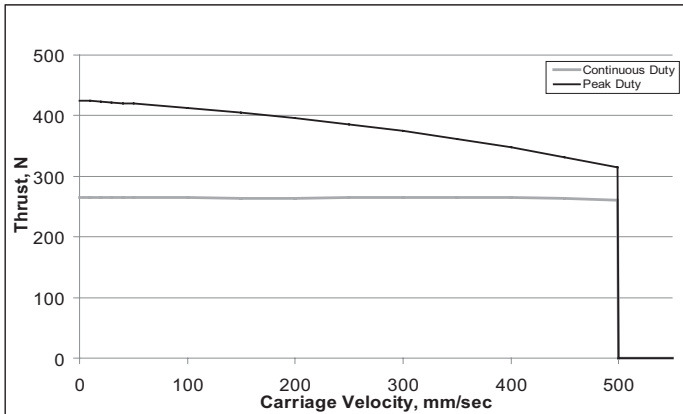

*80 N Dynamic Thrust Limit for Basic Service Life when operated at critical speed limits within average speed requirements stated on pages 84-105.

VL-ST45 - SM23165D @ 48V, 12mm/rev lead ball screw

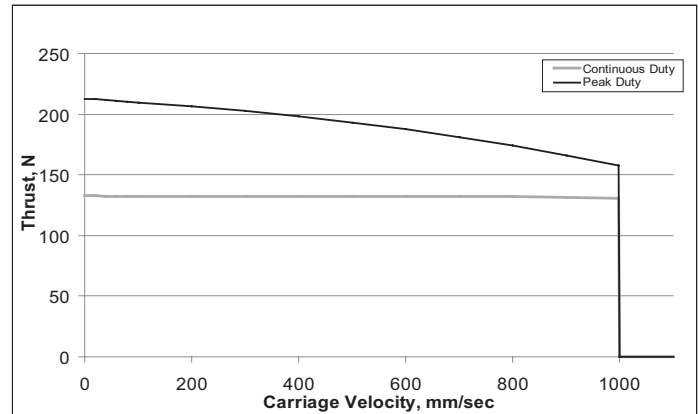

*65 N Dynamic Thrust Limit for Basic Service Life when operated at critical speed limits within average speed requirements stated on pages 84-105.

VL-ST45 - SM23165D @ 42V, 6mm/rev lead ball screw

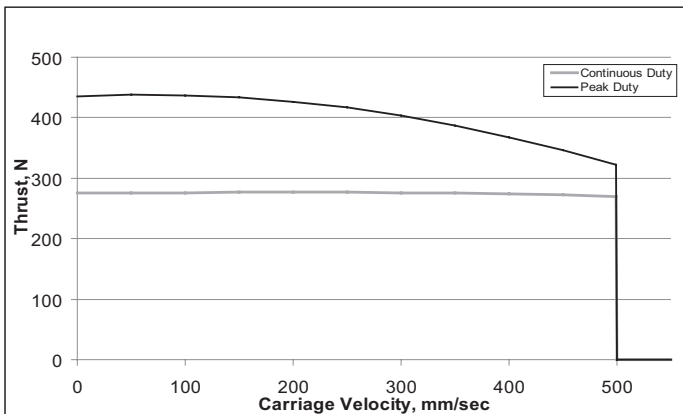

*80 N Dynamic Thrust Limit for Basic Service Life when operated at critical speed limits within average speed requirements stated on pages 84-105.

VL-ST45 - SM23165D @ 42V, 12mm/rev lead ball screw

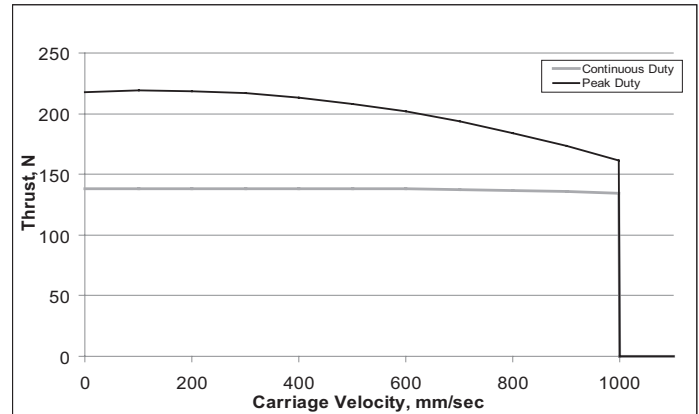

*65 N Dynamic Thrust Limit for Basic Service Life when operated at critical speed limits within average speed requirements stated on pages 84-105.

VL-ST45 - SM23165D @ 24V, 6mm/rev lead ball screw

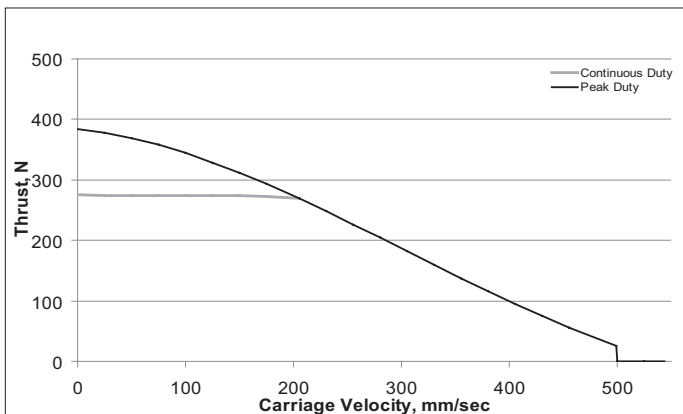

*80 N Dynamic Thrust Limit for Basic Service Life when operated at critical speed limits within average speed requirements stated on pages 84-105.

VL-ST45 - SM23165D @ 24V, 12mm/rev lead ball screw

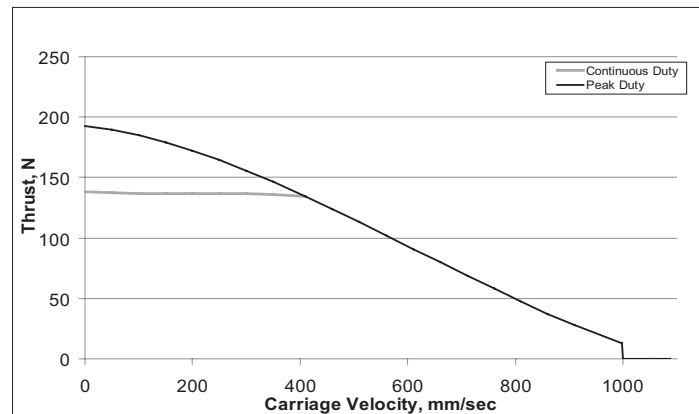

*65 N Dynamic Thrust Limit for Basic Service Life when operated at critical speed limits within average speed requirements stated on pages 84-105.

NOTE: Motor and Actuator specifications are subject to changes without notice. Consult Website and factory for latest data.

OVERVIEW
MOTOR SPECIFICATIONS
LINEAR SYSTEMS
CONNECTIVITY
PERIPHERALS
IP 65 MODELS & CONNECTIVITY
POWER SUPPLIES & SHUNTS
GEAR HEADS
SOFTWARE
APPENDIX

VL-ST45 - SM23165D @ 48V, 6mm/rev lead ball screw

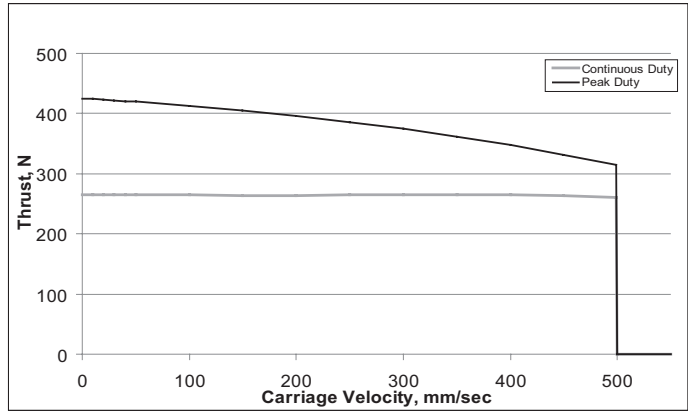

*80 N Dynamic Thrust Limit for Basic Service Life when operated at critical speed limits within average speed requirements stated on pages 84-105.

VL-ST45 - SM23165D @ 48V, 12mm/rev lead ball screw

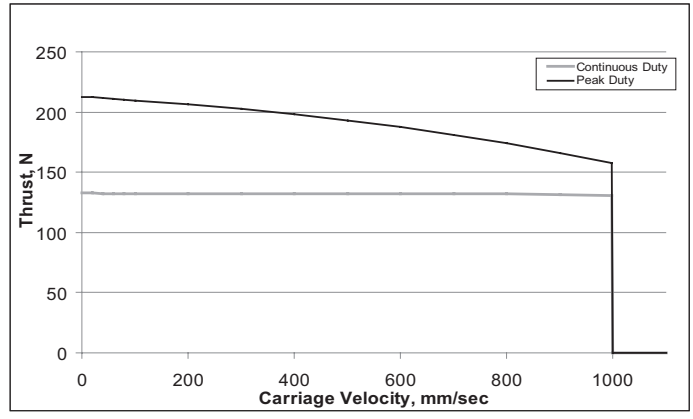

*65 N Dynamic Thrust Limit for Basic Service Life when operated at critical speed limits within average speed requirements stated on pages 84-105.

VL-ST45 - SM23165D @ 42V, 6mm/rev lead ball screw

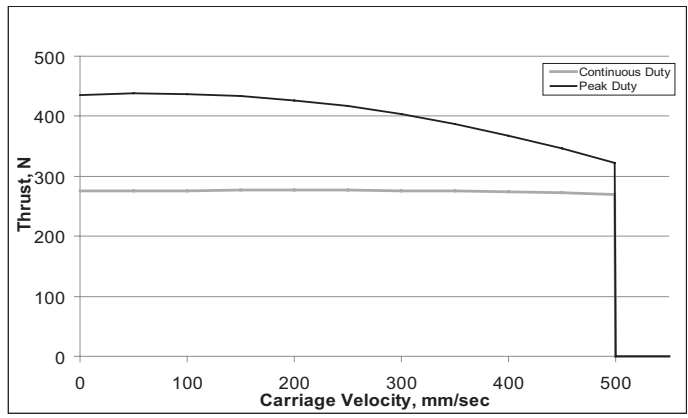

*80 N Dynamic Thrust Limit for Basic Service Life when operated at critical speed limits within average speed requirements stated on pages 84-105.

VL-ST45 - SM23165D @ 42V, 12mm/rev lead ball screw

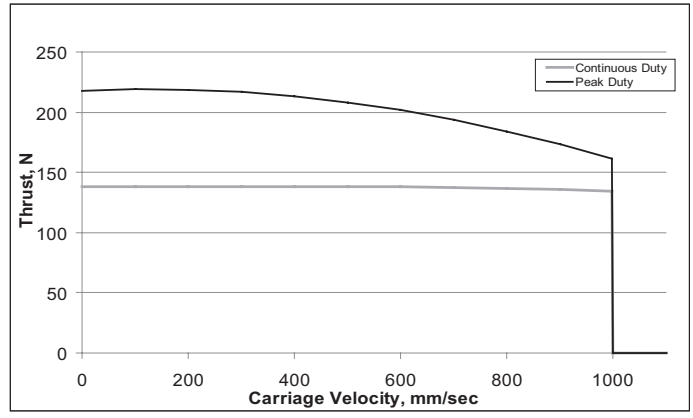

*65 N Dynamic Thrust Limit for Basic Service Life when operated at critical speed limits within average speed requirements stated on pages 84-105.

VL-ST45 - SM23165D @ 24V, 6mm/rev lead ball screw

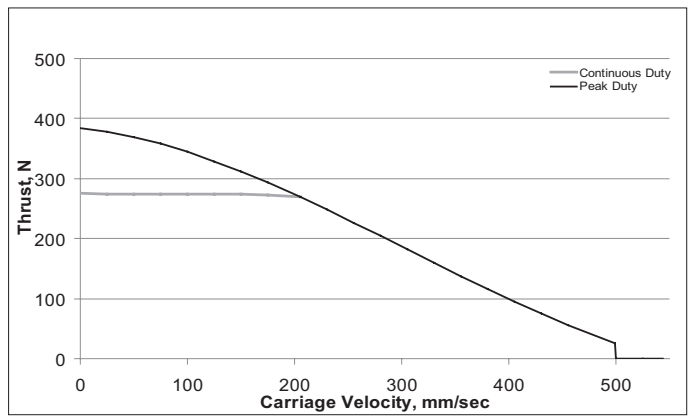

*80 N Dynamic Thrust Limit for Basic Service Life when operated at critical speed limits within average speed requirements stated on pages 84-105.

VL-ST45 - SM23165D @ 24V, 12mm/rev lead ball screw

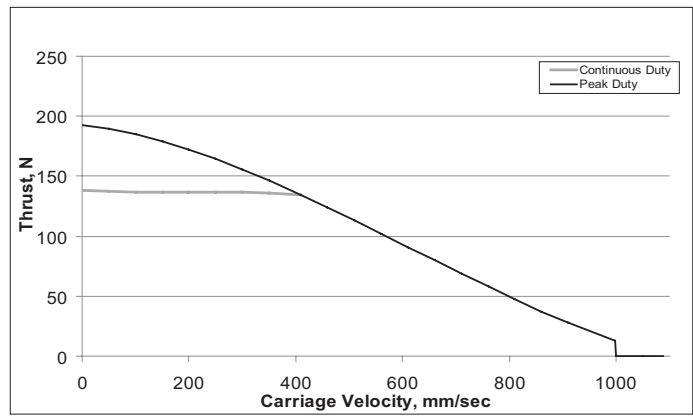

*65 N Dynamic Thrust Limit for Basic Service Life when operated at critical speed limits within average speed requirements stated on pages 84-105.

NOTE: Motor and Actuator specifications are subject to changes without notice. Consult Website and factory for latest data.

VL-ST60 - SM23165DT @ 48V, 6mm/rev lead ball screw

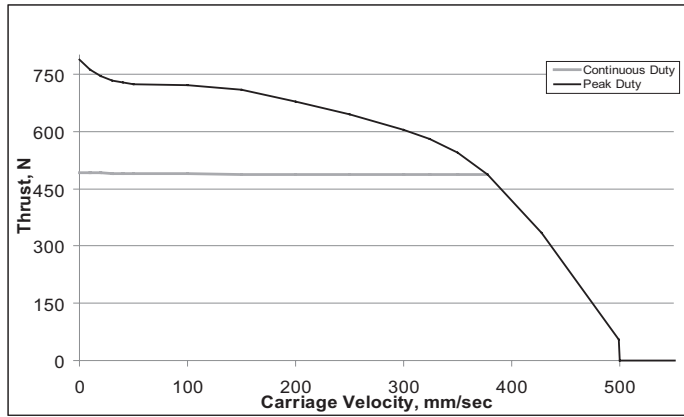

*130 N Dynamic Thrust Limit for Basic Service Life when operated at critical speed limits within average speed requirements stated on pages 84-105.

VL-ST60 - SM23165DT @ 48V, 12mm/rev lead ball screw

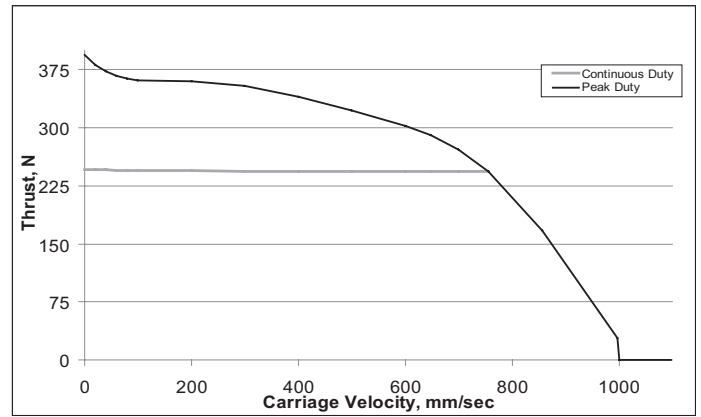

*100 N Dynamic Thrust Limit for Basic Service Life when operated at critical speed limits within average speed requirements stated on pages 84-105.

VL-ST60 - SM23165DT @ 42V, 6mm/rev lead ball screw

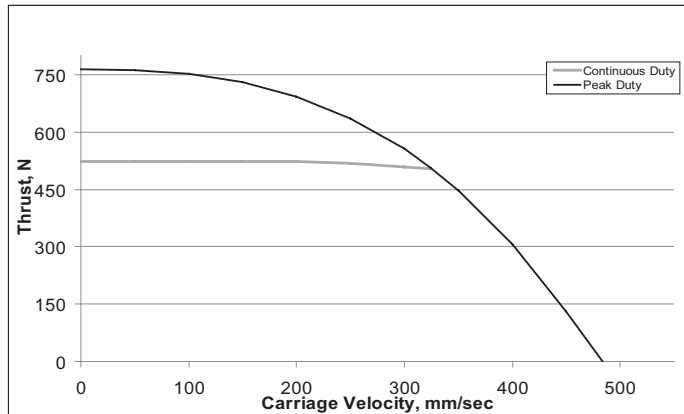

*130 N Dynamic Thrust Limit for Basic Service Life when operated at critical speed limits within average speed requirements stated on pages 84-105.

VL-ST60 - SM23165DT @ 42V, 12mm/rev lead ball screw

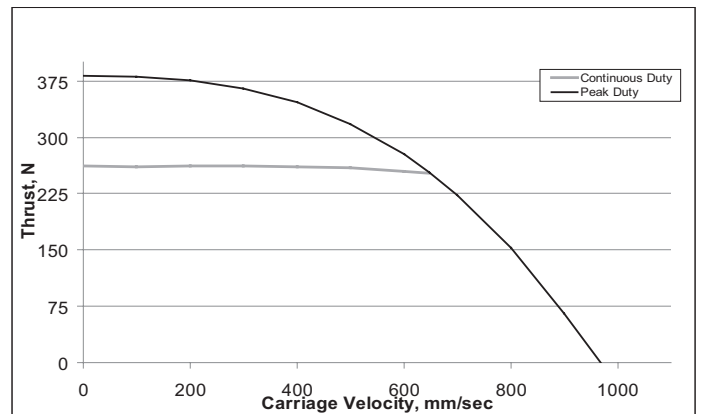

*100 N Dynamic Thrust Limit for Basic Service Life when operated at critical speed limits within average speed requirements stated on pages 84-105.

VL-ST60 - SM23165DT @ 24V, 6mm/rev lead ball screw

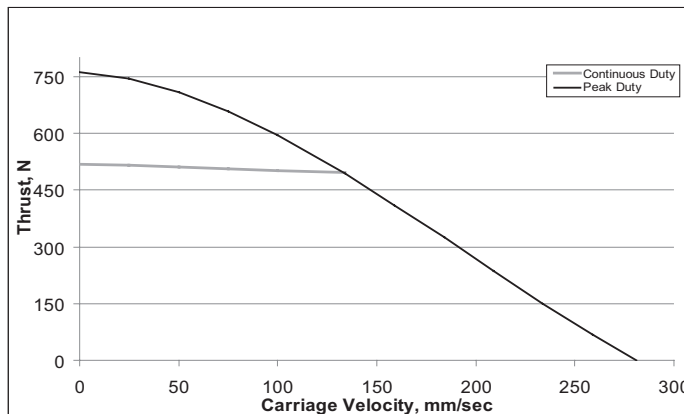

*130 N Dynamic Thrust Limit for Basic Service Life when operated at critical speed limits within average speed requirements stated on pages 84-105.

VL-ST60 - SM23165DT @ 24V, 12mm/rev lead ball screw

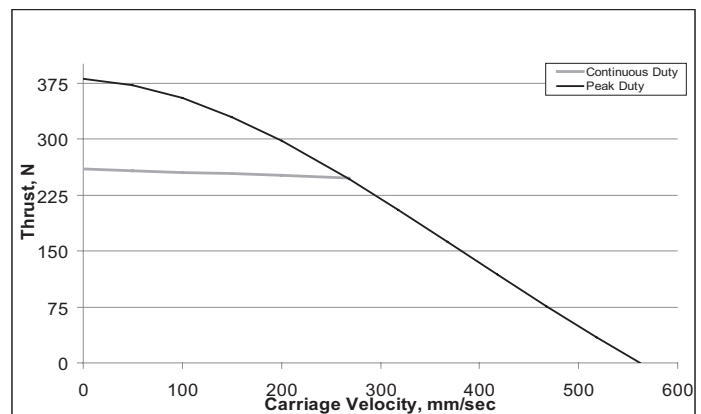

*100 N Dynamic Thrust Limit for Basic Service Life when operated at critical speed limits within average speed requirements stated on pages 84-105.

NOTE: Motor and Actuator specifications are subject to changes without notice. Consult Website and factory for latest data.

OVERVIEW
MOTOR SPECIFICATIONS
LINEAR SYSTEMS
CONNECTIVITY
PERIPHERALS
IP 65 MODELS & CONNECTIVITY
POWER SUPPLIES & SHUNTS
GEAR HEADS
SOFTWARE
APPENDIX

VL-ST60 - SM23165D @ 48V, 6mm/rev lead ball screw

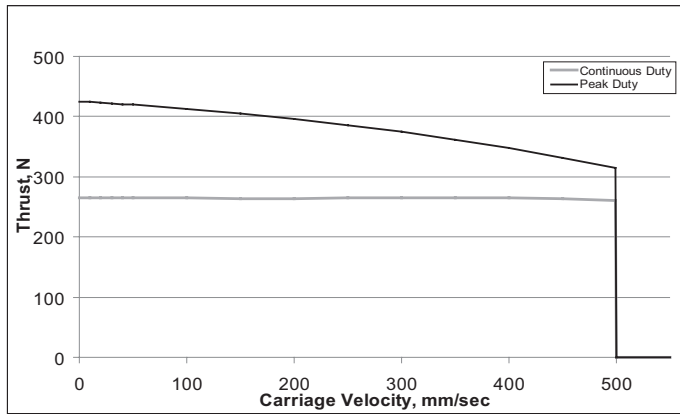

*130 N Dynamic Thrust Limit for Basic Service Life when operated at critical speed limits within average speed requirements stated on pages 84-105.

VL-ST60 - SM23165D @ 48V, 12mm/rev lead ball screw

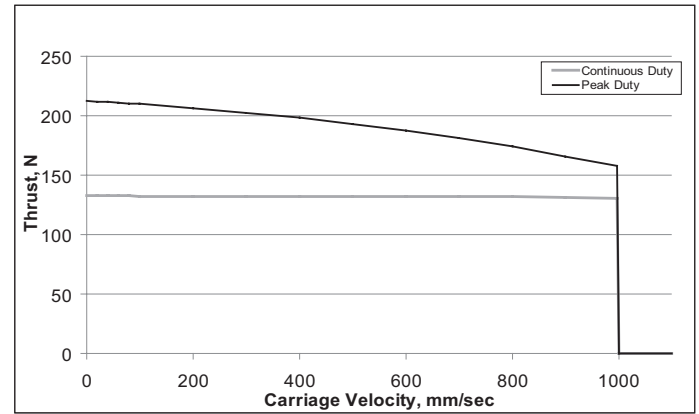

*100 N Dynamic Thrust Limit for Basic Service Life when operated at critical speed limits within average speed requirements stated on pages 84-105.

VL-ST60 - SM23165D @ 42V, 6mm/rev lead ball screw

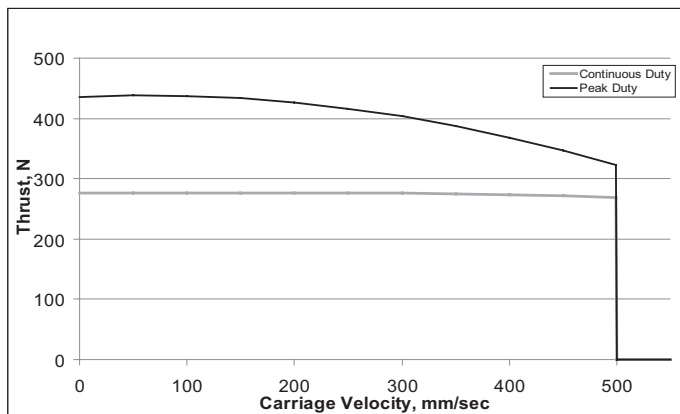

*130 N Dynamic Thrust Limit for Basic Service Life when operated at critical speed limits within average speed requirements stated on pages 84-105.

VL-ST60 - SM23165D @ 42V, 12mm/rev lead ball screw

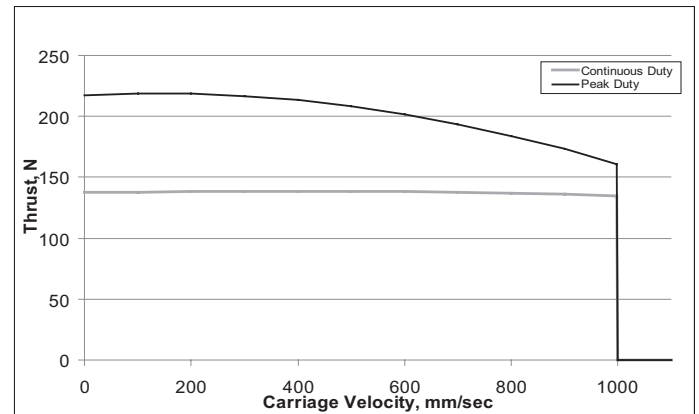

*100 N Dynamic Thrust Limit for Basic Service Life when operated at critical speed limits within average speed requirements stated on pages 84-105.

VL-ST60 - SM23165D @ 24V, 6mm/rev lead ball screw

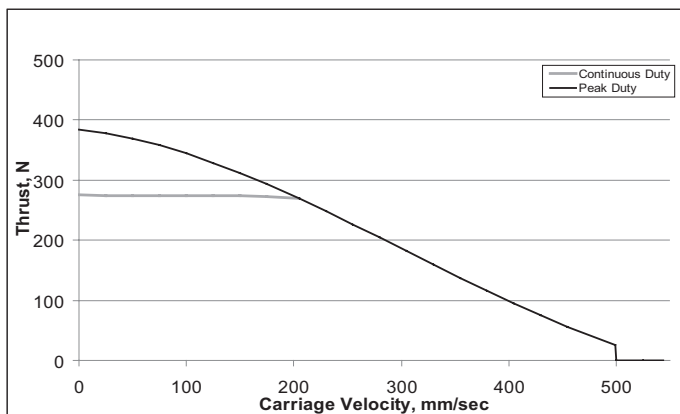

*130 N Dynamic Thrust Limit for Basic Service Life when operated at critical speed limits within average speed requirements stated on pages 84-105.

VL-ST60 - SM23165D @ 24V, 12mm/rev lead ball screw

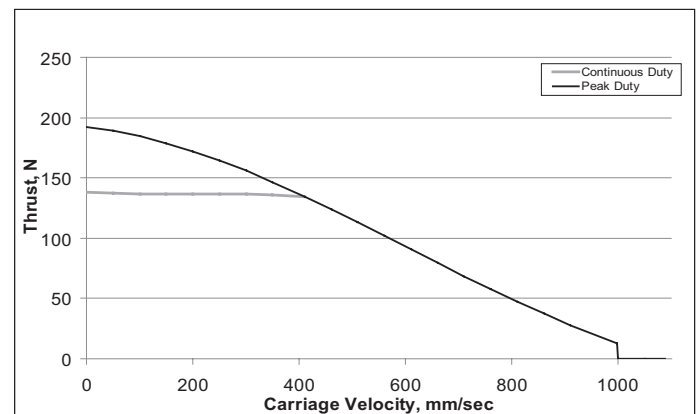

*100 N Dynamic Thrust Limit for Basic Service Life when operated at critical speed limits within average speed requirements stated on pages 84-105.

NOTE: Motor and Actuator specifications are subject to changes without notice. Consult Website and factory for latest data.

OEM Dynamics Website - www.oemdynamics.com

OEM Dynamics is getting ready to launch their new website! The new website will be cleaner, more efficient, and easier to navigate with the wealth of product and industry information you expect from Animatics. The new OEM Dynamics site will also feature sample programs, application guides, how-to videos and application videos.

Part Number Generator

Find the exact part number you need to place an order, including the new Class 5 SmartMotor™ to complete your linear motion system. Drop down menus and distinguished, individual categories ensure that the part number generated is precisely the one you will need with all of the options included.

The screenshot displays the OEM Dynamics website interface. At the top left is the OEM Dynamics logo. A navigation bar contains buttons for 'About Us', 'Actuators', 'Gantry', 'TT Robot', 'Support', and 'Sales Offices', along with a search box. Below the navigation bar is a breadcrumb trail: 'Supports > Knowledge Base > Actuators'. The main content area features a banner for 'Original Electro-Mechanical Solutions' with the tagline 'A member of the Animatics family'. Below the banner is a collection of various actuators and a large 'SMART Motor' logo. To the right is a 'Knowledge Base' sidebar with a list of links: 'Knowledge Base Home', 'Connection Map', 'SmartMotor™', 'Actuators', 'Power Supplies', and 'Software'. A large blue starburst graphic with the word 'NEW' is positioned in the lower right of the main content area. The footer contains a 'Q&A Forum' icon, an email icon with the address 'service@animatics.com', and a phone icon with the number '+1 408.748.8721'.

Introduction to Class 5 Connectivity

OVERVIEW
MOTOR SPECIFICATIONS
LINEAR SYSTEMS
CONNECTIVITY
PERIPHERALS
IP 65 MODELS & CONNECTIVITY
POWER SUPPLIES & SHUNTS
GEAR HEADS
SOFTWARE
APPENDIX

Power:

Each SmartMotor™ is operated from 24 to 48VDC. Some of the larger SmartMotor servos can draw high current.

It is highly recommended to use heavy gage wire to connect the larger motors. As a result, the “Add-A-Motor” is recommended for the 17 and 23 frame series only.

Communications:

Each SmartMotor has a primary RS-232 serial port and a secondary RS-485 port by re-assignment of ports E and F of the 7 I/O points. Up to 100 SmartMotor servos may be separately addressed and are identifiable on either RS-232 or RS-485.

The most common and cost effective solution is typically RS-232 serial communications. Under this structure, each motor is placed in an electrical serial connection such that the transmit line of one motor is connected to the receive line of the next. Each motor will be set to “echo” the incoming data to the next motor down with approximately 1 millisecond propagation delay. There is no signal integrity loss from one motor to the next, which results in highly reliable communications.

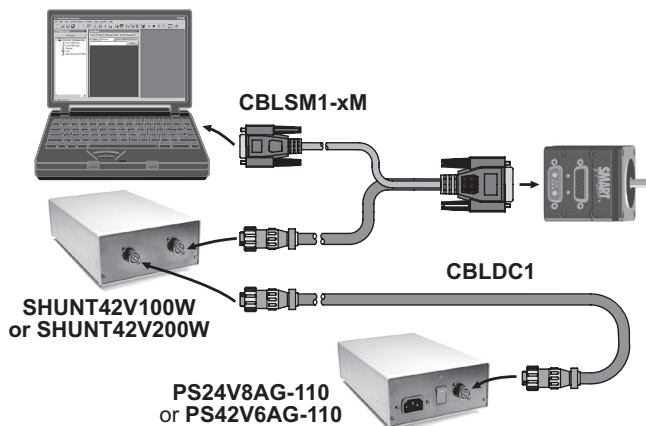

The following cables/devices are used for RS-232 and Power connectivity:

- CBLPWRCOM2-xM** Power and communications cable with flying leads or in conjunction with DIN-RS232 8 channel isolated communications board
- CBLSM1-xM** Power and communications cable with DB-9 serial connector and power supply connector that fits our enclosed power supplies
- CBLSM1-DEMO** Testing cable used with our PWR116 “laptop” type power supply
- CBLSM1-x-y-z** Custom length multi-drop RS-232 daisy chain cable

The following cables are used for RS-485 and Power connectivity:

- RS485-ISO** Converts primary RS-232 to isolated RS-485 (Note: uses Port G I/O pin)
- CBLSM2-x-y-z** Custom multi drop isolated RS-485 (multiple RS485-ISO adapters)

Interfacing with I/O devices:

Each SmartMotor has 7 TTL level user-configurable I/O. Each can be used as either inputs or outputs.

The following is a quick review of I/O interfacing connectivity options:

- CBLIO5V-xM** Direct connection to 5V TTL I/O
- CBLIO5V-xM via OPTO2** 24VDC isolation and conversion of 5V signals
- CBLIO5V-xM via DINIO7** Motor breakout board to industry standard OPTO relays
- CBLIO-ISO1-xM** Isolated 24VDC logic conversion cable

The following pages are a roadmap to motor connectivity. These pages show the physical layout of how cables are used including power, communications and I/O interconnection.

Class 5 Connector Pinouts

PIN	MAIN POWER	Specifications:	P1
1	I/O – 6 GP or “G” command	25mAmp Sink or Source 10Bit 0-5VDC A/D	Redundant connection on I/O connector
2	+5VDC out	50mAmps Max (total)	
3	RS-232 Transmit	Channel(0)	115.2KBaud Max
4	RS-232 Receive	Channel(0)	115.2KBaud Max
5	SIG Ground		
A1	Main Power: +20-48VDC		
A2	Ground		

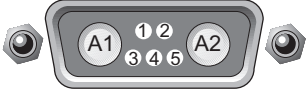

7W2 Combo D-sub Connector

PIN	I/O CONNECTOR (5VTTL I/O)	Specifications:	P2
1	I/O – 0 GP or Enc. A or Step Input	25mAmp Sink or Source 10Bit 0-5VDC A/D	1.5MHz max as Enc or Step input
2	I/O – 1 GP or Enc. B or Dir. Input	25mAmp Sink or Source 10Bit 0-5VDC A/D	1.5MHz max as Enc or Dir. Input
3	I/O – 2 Positive Over Travel or GP	25mAmp Sink or Source 10Bit 0-5VDC A/D	
4	I/O – 3 Negative Over Travel or GP	25mAmp Sink or Source 10Bit 0-5VDC A/D	
5	I/O – 4 GP or RS-485 A Channel(1)	25mAmp Sink or Source 10Bit 0-5VDC A/D	115.2KBaud Max
6	I/O – 5 GP or RS-485 B Channel(1)	25mAmp Sink or Source 10Bit 0-5VDC A/D	115.2KBaud Max
7	I/O – 6 GP or “G” command	25mAmp Sink or Source 10Bit 0-5VDC A/D	Redundant connection on Main Power Connector
8	Phase A Encoder Output		
9	Phase B Encoder Output		
10	RS-232 Transmit	Channel(0)	115.2KBaud Max
11	RS-232 Receive	Channel(0)	115.2KBaud Max
12	+5VDC Out	50mAmps Max (total)	
13	SIG Ground		
14	Ground		
15	Main Power: +20-48VDC	if -DE Option, Control Power separate from Main Power	

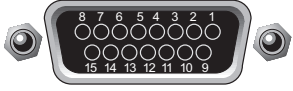

P2 DB-15 D-sub Connector

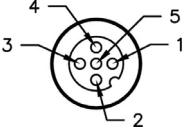
PIN	CAN bus	Connection:	P3
1	NC	NC	M12 5-PIN FEMALE END VIEW 
2	NC	NC	
3	GND_CAN	Isolated CAN ground	
4	CAN-H	1M Baud max	
5	CAN-L	1M Baud max	

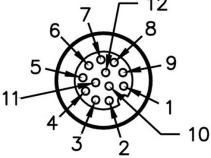
PIN	Isolated 24VDC I/O Connector	Max Load (sourcing)	P4
1	I/O – 16 GP	150mAmps	M12 12-PIN FEMALE END VIEW 
2	I/O – 17 GP	150mAmps	
3	I/O – 18 GP	150mAmps	
4	I/O – 19 GP	150mAmps	
5	I/O – 20 GP	300mAmps	
6	I/O – 21 GP	300mAmps	
7	I/O – 22 GP	300mAmps	
8	I/O – 23 GP	300mAmps	
9	I/O – 24 GP	300mAmps	
10	I/O – 25 GP	300mAmps	
11	+24Volts Input	18-32VDC	
12	GND-I/O		

Class 5 LEDs and Connectors

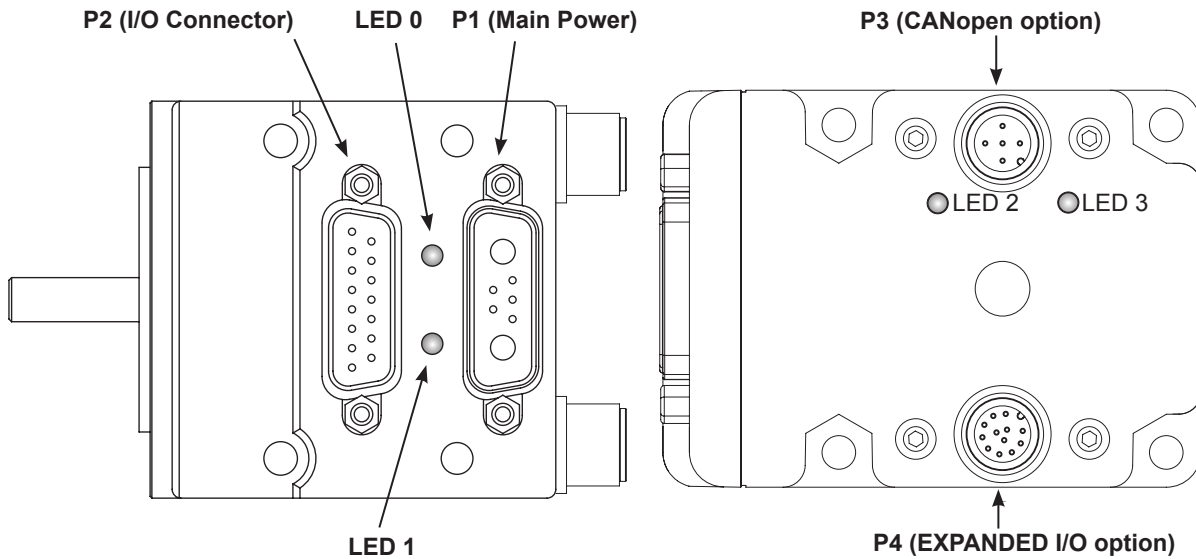

LED Status Power-up:

with no program
the travel limit inputs are not grounded:
LED0 will be solid red indicating the motor is
in a fault state due travel limit fault.
LED1 will be off

LED Status Power-up:

with no program
and the travel limits are hard wired to ground:
LED0 will be solid red for 500 milliseconds
and then begin flashing green.
LED1 will be off

LED Status Power-up:

with a program that only disables travel limits and
nothing else
LED0 will be solid red for 500 milliseconds
and then begin flashing green.
LED1 will be off

LED0: Drive Status
 OFF :No Power
 Solid green :Drive On
 Flashing green :Drive Off
 Flashing red :Watchdog Fault
 Solid red:Major Fault
 Alt. red/green :In Boot Load, Needs
 Firmware

LED1: Trajectory Status
 OFF :Not Busy
 Solid green :Drive On, Trajectory In
 Progress

LED2 CAN Bus Network Fault (Red LED)
 Off :No Error
 Single Flash. :At least One Error
 exceeded Limit
 Double Flash :Heartbeat or Guard Error
 Solid :Busy Off State

LED3: CAN Bus Network Status (Green LED)
 Blinking :Pre-Operational State,
 (during boot-up)
 Solid :Normal Operation
 Single :Device is in Stopped State

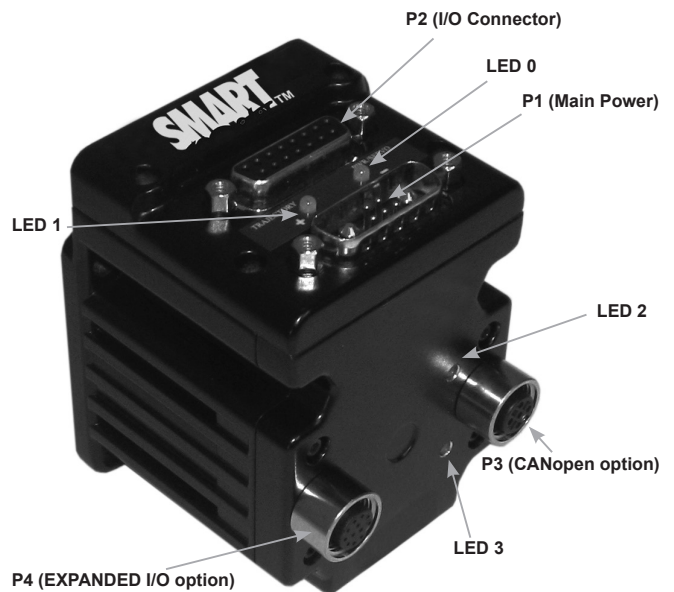

Class 5 Connection Maps

PIN	DESCRIPTION
1	A I/O
2	B I/O
3	C I/O
4	D I/O
5	E I/O
6	F I/O
7	G I/O
8	Encoder A Out
9	Encoder B Out
10	RS232 Transmit
11	RS232 Receive
12	+5V Out
13	Ground
14	Power Ground
15	Power

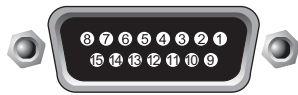

15 Pin D-Sub I/O

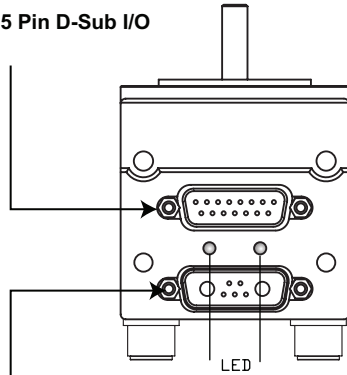

7 Pin Combo D-Sub Power & I/O



PIN	DESCRIPTION
A1	+20V to +48V DC
A2	Power Ground
1	Sync or I/O
2	+5V Out
3	RS232 Transmit
4	RS232 Receive
5	RS232 Ground

12 Pin Expanded I/O Connector

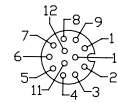

PIN	DESCRIPTION
1	I/O-16 GP
2	I/O-17 GP
3	I/O-18 GP
4	I/O-19 GP
5	I/O-20 GP
6	I/O-21GP
7	I/O-22 GP
8	I/O-23GP
9	I/O-24 GP
10	I/O-25 GP
11	+24 Volts Input
12	GND I/O

5 Pin CAN

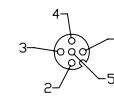

PIN	DESCRIPTION
1	NC
2	NC
3	GND CAN
4	CAN-H
5	CAN-L

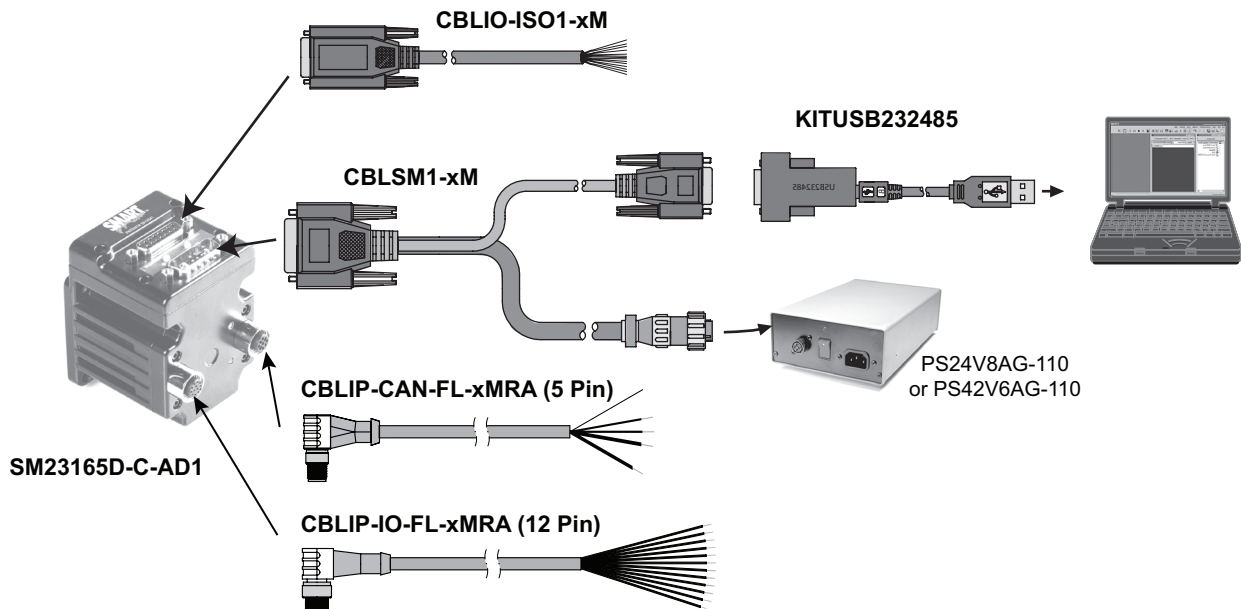

Class 5 Multi-Axis Connection Maps

RS232 Multidrop using Add-A-Motor Cable

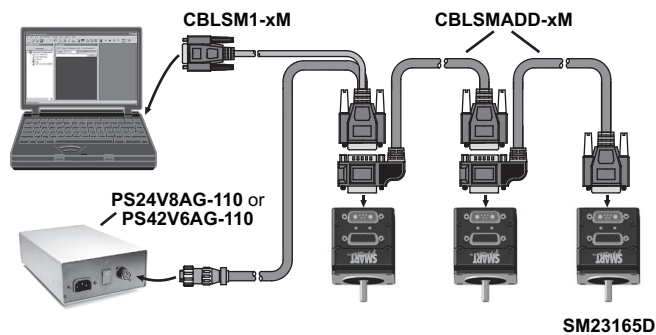

15 Amps maximum continuous load

CAN Bus Multidrop using CAN Bus Y Cables

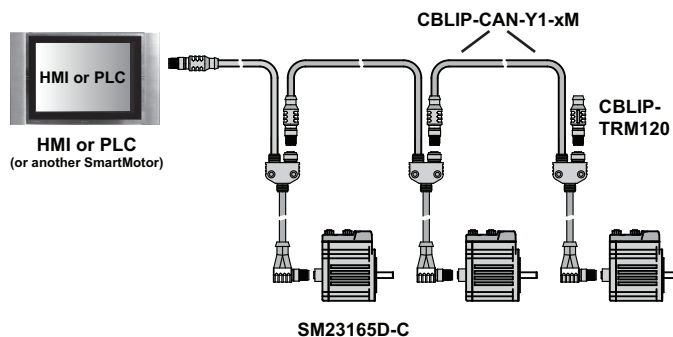

HIGHLY RECOMMENDED OPTION. PLEASE READ !

Hardware "DE" Option:

The DE option allows the controller and drive-amplifier to be powered from separate 24-48 VDC power supplies.

- Controller can be powered from a standard 24 VDC supply
- **Position will not be lost on loss-of-drive-power**
- **No need to re-home**
- Load surges will not cause power surge on controller
- Standard battery options are made simpler

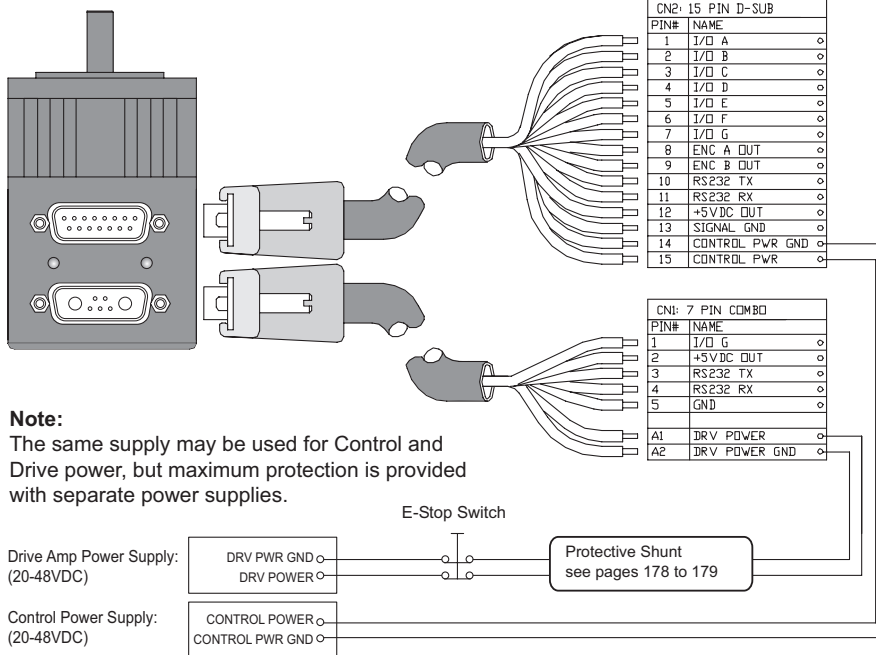

Note:
The same supply may be used for Control and Drive power, but maximum protection is provided with separate power supplies.

Note: All IP sealed SmartMotors are designed to always have separate drive and control power. As a result, no DE designation is available for IP sealed SmartMotors. Control power on IP sealed SmartMotors is rated for 24VDC, maximum of 32VDC.

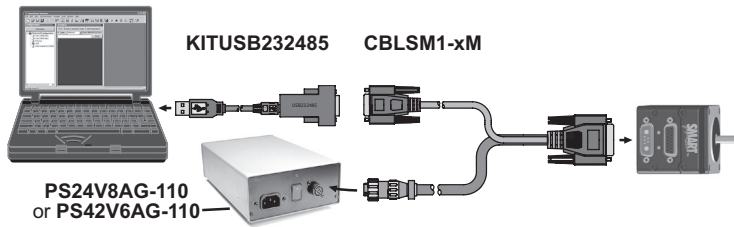

**RS-232 Communications
Using USB Adapter**

**RS-232 Communications with
Power Supply & Protective Shunt**

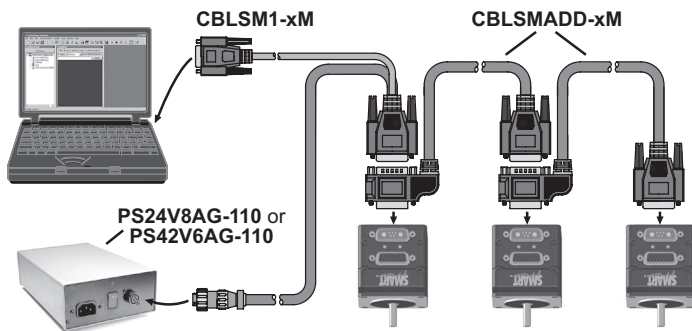
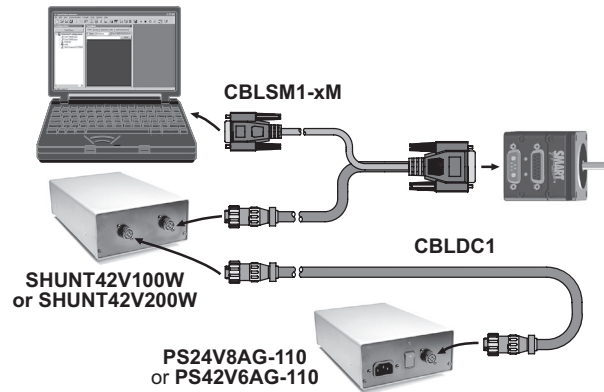

**RS-232 Multidrop using
Add-A-Motor™ Cables**

**RS-232 Multidrop using
Custom Order Cable**

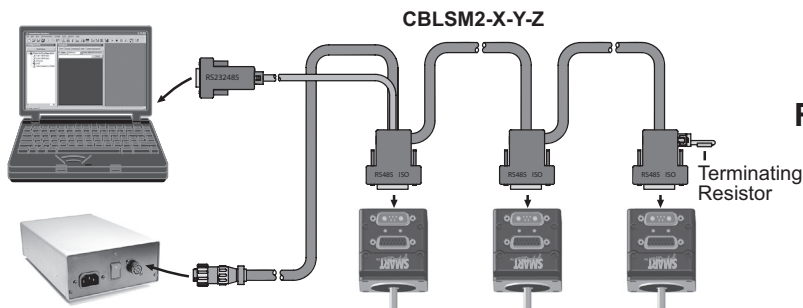
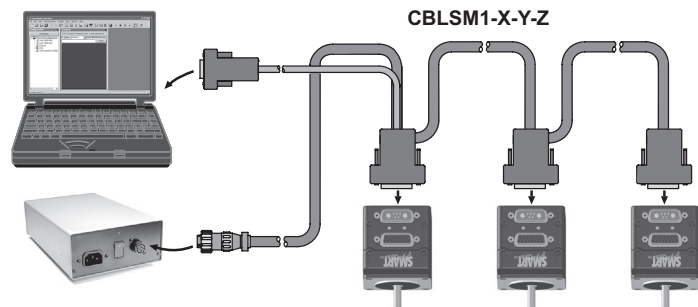

**RS-485 Isolated Communications
Using Custom Order Cable**

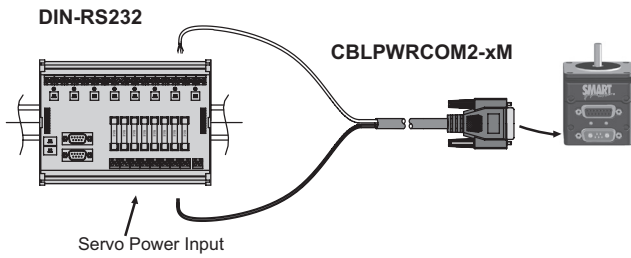

Isolated RS-232 Communications for up to 8 SmartMotor servos

Demonstration & Development Configurations

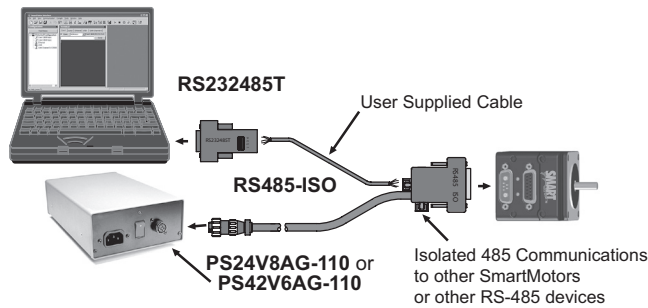
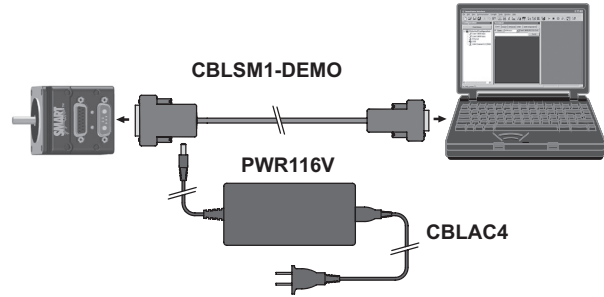

Isolated RS-485 Communications

Interfacing with 24V I/O Devices

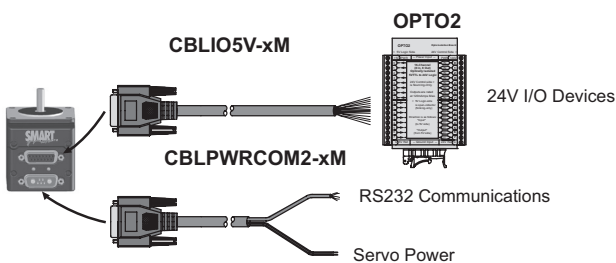
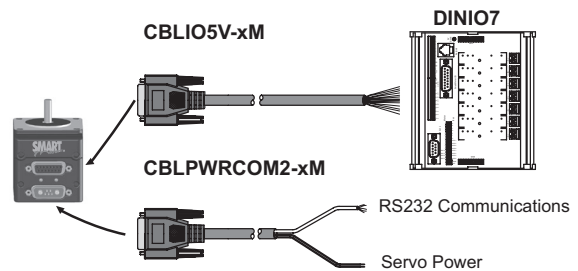
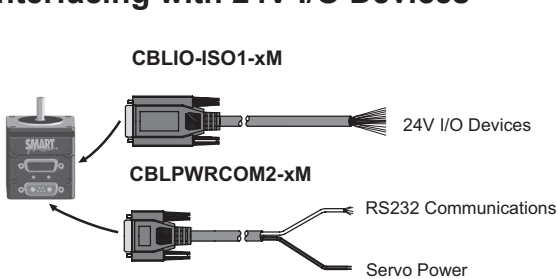

Recommended Power Supply

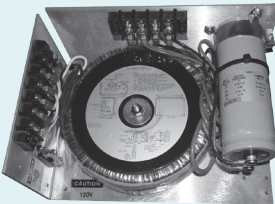

PS42V20AF series

Recommended Shunts



SHUNT42V100W-OF



SHUNT42V200W-OF

CBLSM1-3M

Power and Communications Cable for Main 7W2 Connector on Animatics SmartMotor™

CBLSM1 series is the main power and communications cable consisting of a 7W2 main motor connector split out to a pre-wired RS-232 DB-9 connector to plug directly into any standard PC serial port.

The power is split off and has a connector that plugs into our enclosed frame power supplies.

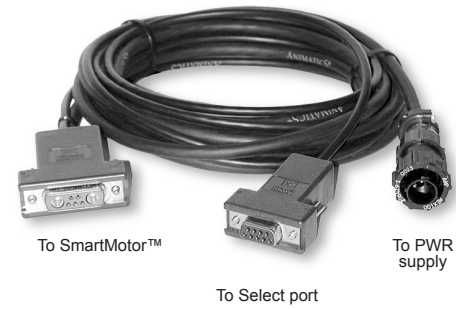

Standard Length

Part Number	Length
CBLSM1-3M	3 meters
CBLSM1-10M	10 meters

Custom Length

Part Number	Length
CBLSM1-x	x (in feet)

Note: Communications Shield is connected at the DB-9 end, but NOT the motor end. The power cable is connected at the motor connector shell but electrically isolated from the any internal electronic components.

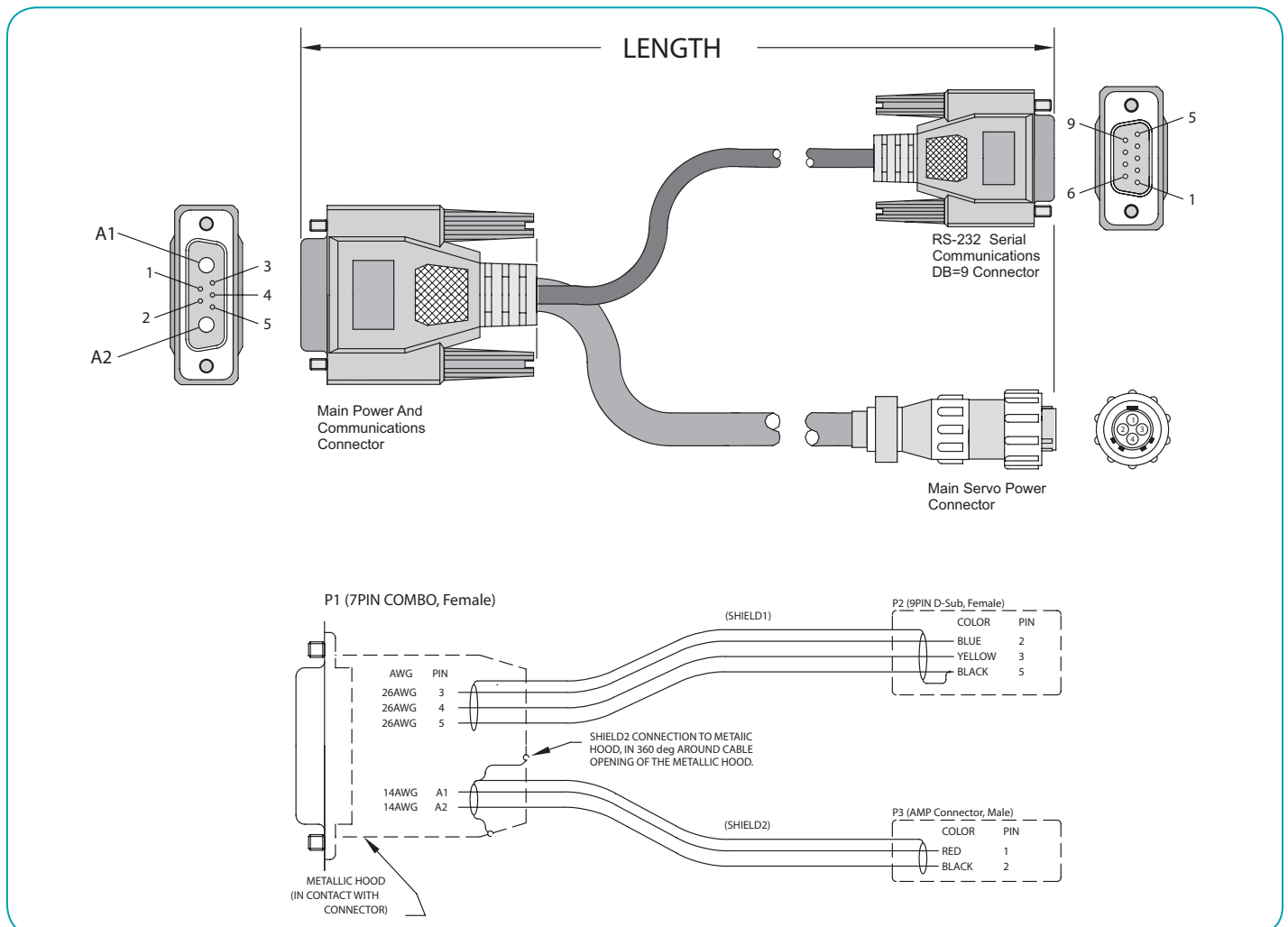

CBLPWRCOM2-xM

Power and Communications Cable (Flying Leads) for Main 7W2 Connector on Animatics SmartMotor™.

CBLPWRCOM2 series a Power and communications cable consisting of a 7W2 main motor connector with communications internally shielded from power and a full shield over entire length terminating at a metal jacket inside the over-molded connector.

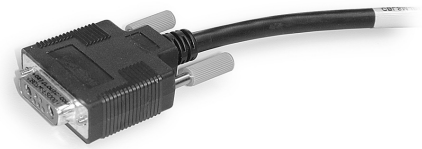

Part Number	Length
CBLPWRCOM2-3M	3 meters
CBLPWRCOM2-5M	5 meters
CBLPWRCOM2-10M	10 meters

Note: Communications Shield is connected at the DB-9 end, but NOT the motor end. The power cable is connected at the motor connector shell but electrically isolated from the any internal electronic components.

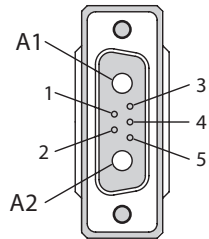
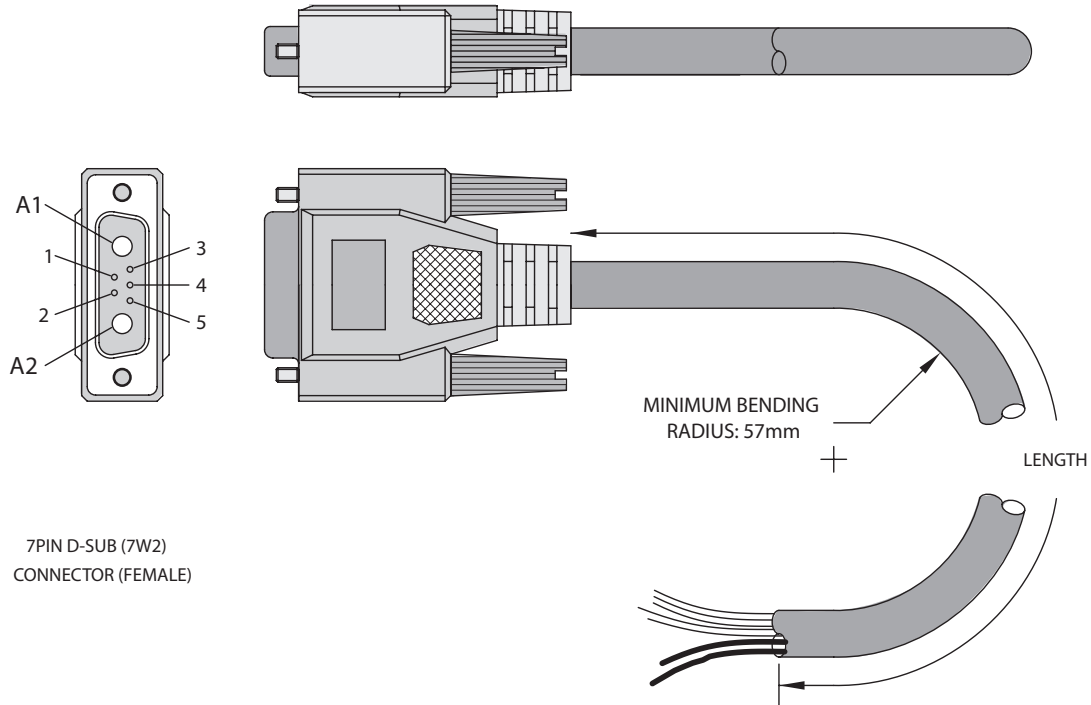

7PIN D-SUB (7W2)
CONNECTOR (FEMALE)

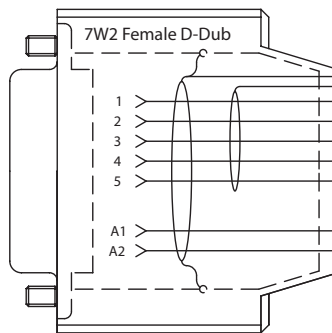

FLYING LEAD

PIN	FUNCTION	COLOR	AWG
1	G-SYN	WHITE	26
2	5VDC	RED	26
3	RS232 Tx	BLUE	26
4	RS232 Rx	YELLOW	26
5	SIG GND	BLACK	26
	SHIELD1		
A1	PWR	RED	14
A2	PWR GND	BLACK	14
	SHIELD2		

CBLSMADD-xM (Animatics™ “Add-A-Motor™” Cable)

Power and Communications Daisy Chain Cable for networking Power and Communications to multiple Animatics SmartMotor Servos.

CBLSMADD series is the main power and communications cable consisting of a feed-through 7W2 main motor connector split out to a single second motor 7W2 connector.

The cable is designed to allow ease of connection to multiple motors in a single RS-232 serial daisy chain network. The Main Power Ground wire is of a larger gauge to decrease noise emissions at the ground-plane level. The RS-232 Communications lines are internally shielded from the power lines.

Part Number	Length
CBLSMADD-0.3	0.3 meters
CBLSMADD-1.0	1 meters
CBLSMADD-3.0	3 meters
CBLSMADD-7.5	7.5 meters

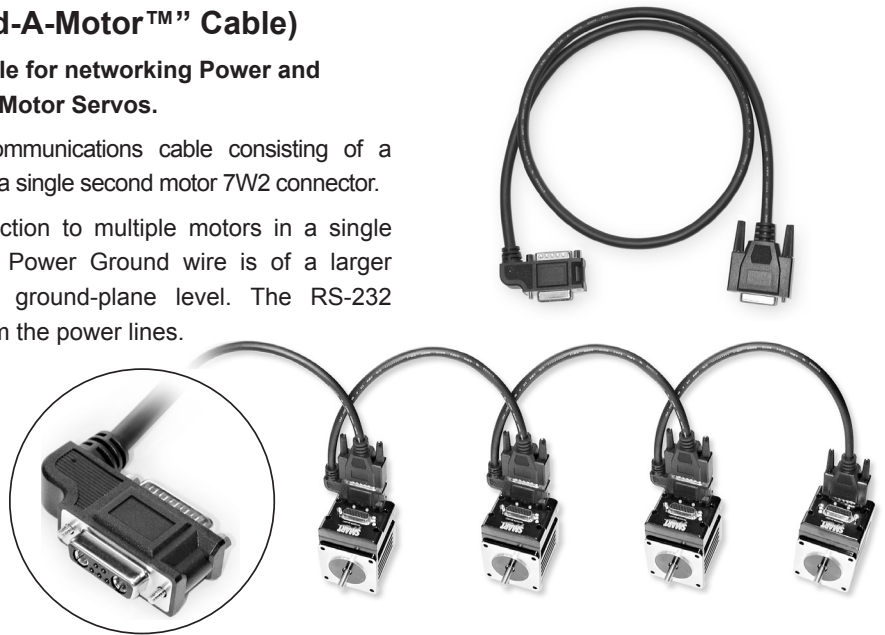

Note: Due to gauge of the main power lines, it is not recommended to use the “Add-A-Motor” cables with the larger 34 frame SmartMotor. If there is just one 34 frame SmartMotor in a system design, then it should be the first motor in the chain so as to minimize voltage drop effects over the entire network.

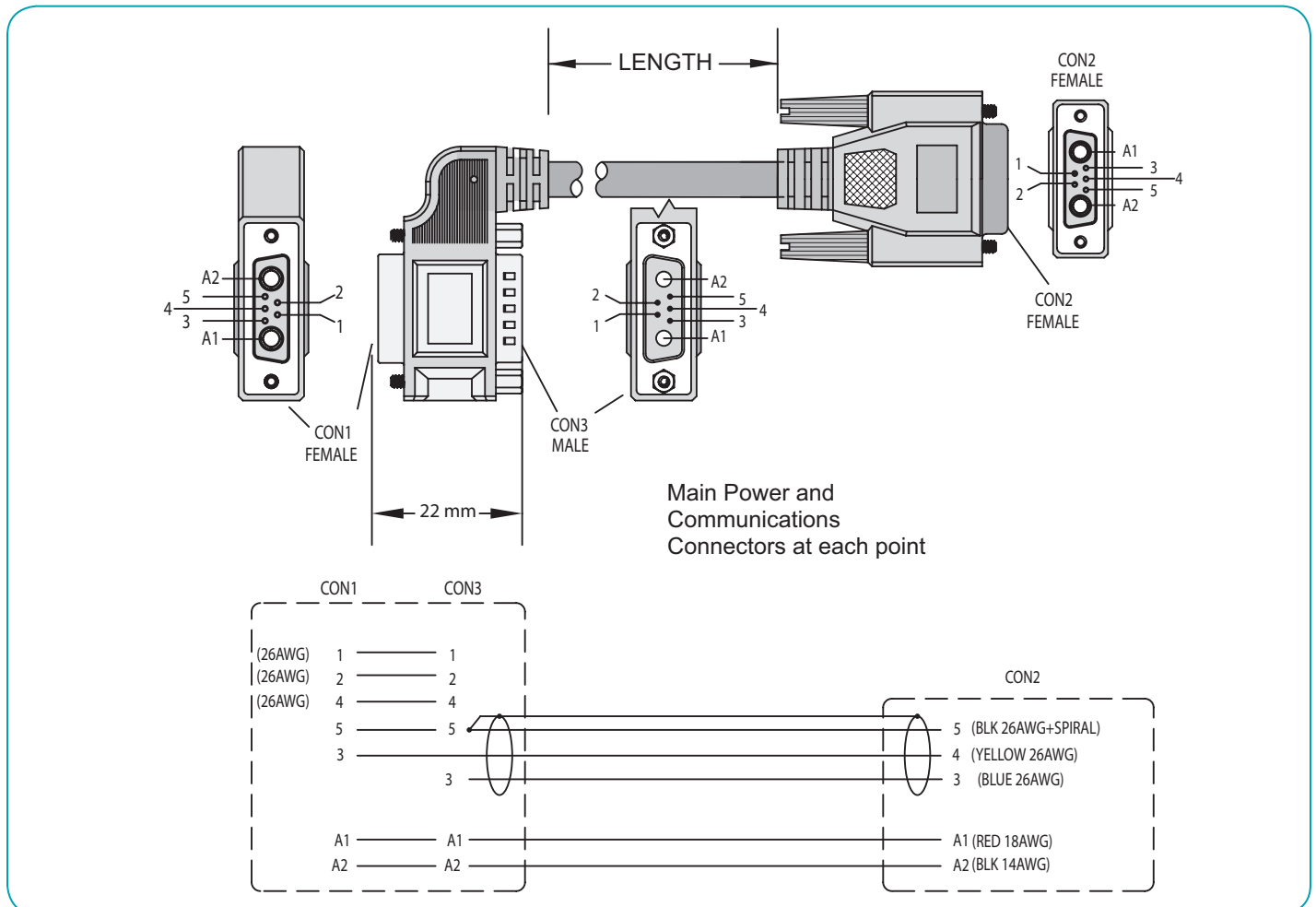

CBLIO5V 5V TTL I/O Interface Cable

Main I/O connector Cable (Flying Leads) for DB-15 Connector on Animatics SmartMotor™.

CBLIO5V series is for all 5VTTL I/O, communications, encoder output, and control power input (when needed for -DE option Motors).

The cable is organized in separately shielded twisted pairs to provide better noise immunity and lower emissions.



Part Number	Length
CBLIO5V-3M	3 meters
CBLIO5V-5M	5 meters
CBLIO5V-10M	10 meters

Note: The shields DO NOT have electrical contact with each other or the connector shell. This allows for proper grounding in the control cabinet or at termination point determined by user thereby eliminating ground loops.

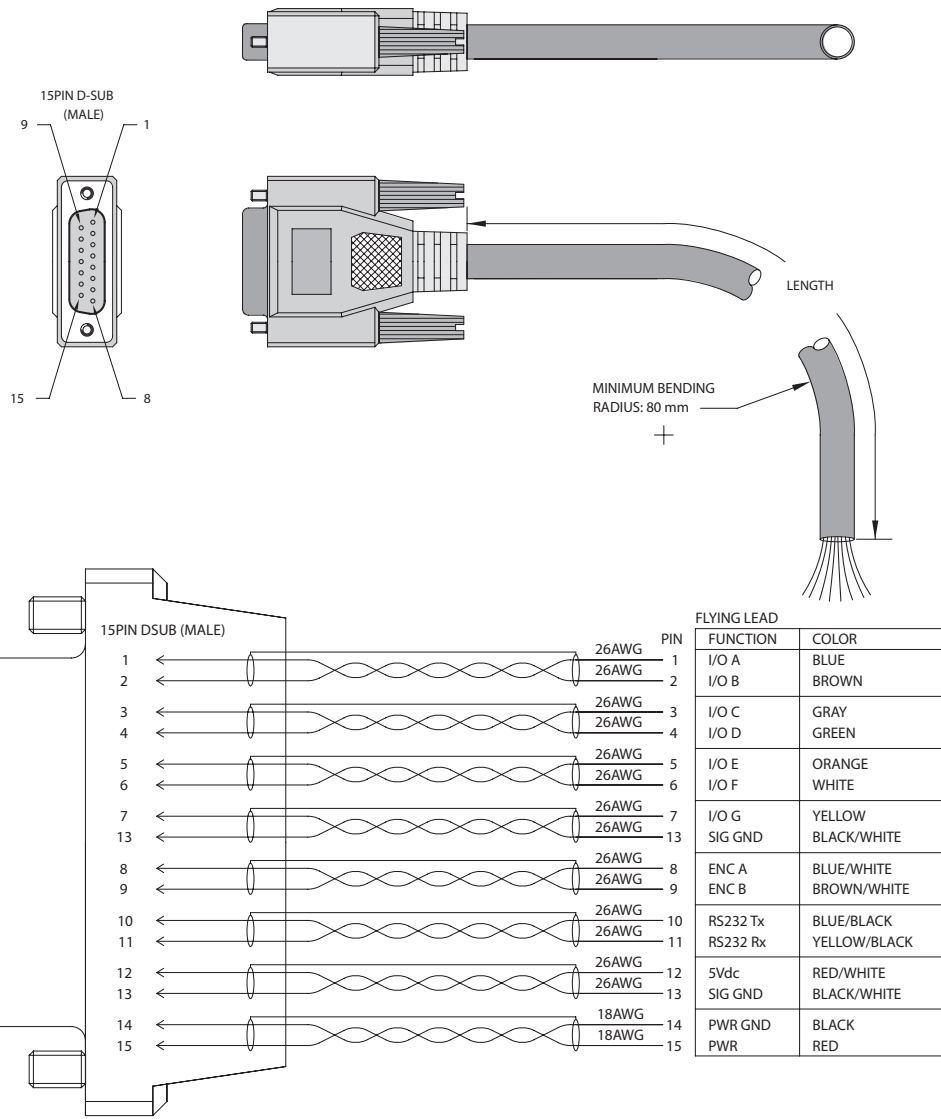

OVERVIEW
MOTOR SPECIFICATIONS
LINEAR SYSTEMS
CONNECTIVITY
PERIPHERALS
IP 65 MODELS & CONNECTIVITY
POWER SUPPLIES & SHUNTS
GEAR HEADS
SOFTWARE
APPENDIX

CBLIO-ISO1 24VDC TTL I/O Converter Cable

The CBLIO-ISO1 cable provide optically isolated 24VDC I/O interface to the controller.

The cable is user configurable as 4 inputs and 3 outputs OR 5 inputs and 2 outputs.

Additionally, this cable provides direct connection to:

- RS-232 Primary Communications Port (Ch. 0)
- Encoder Output
- Control Power Input



Part Number	Length
CBLIO-ISO1-3M	3 meter
CBLIO-ISO1-5M	5 meter
CBLIO-ISO1-10M	10 meter

It can be used with standard or DE option Animatics SmartMotor™

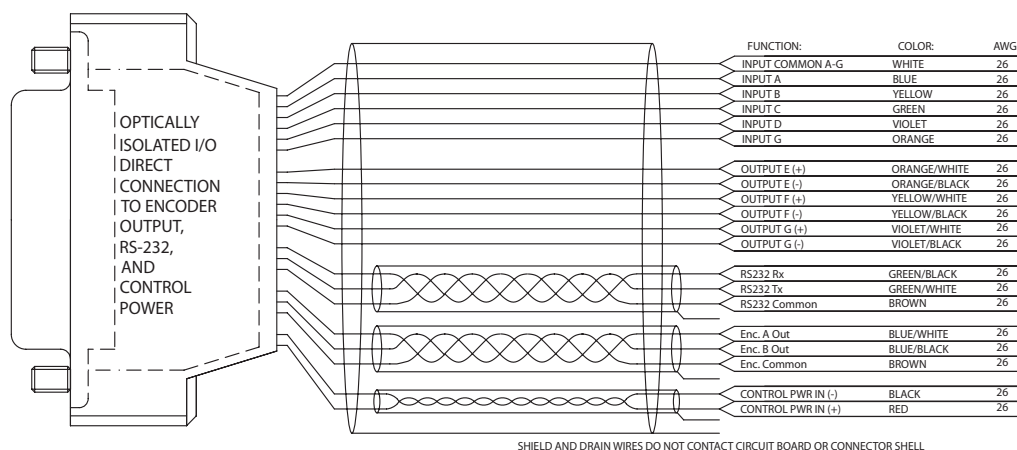
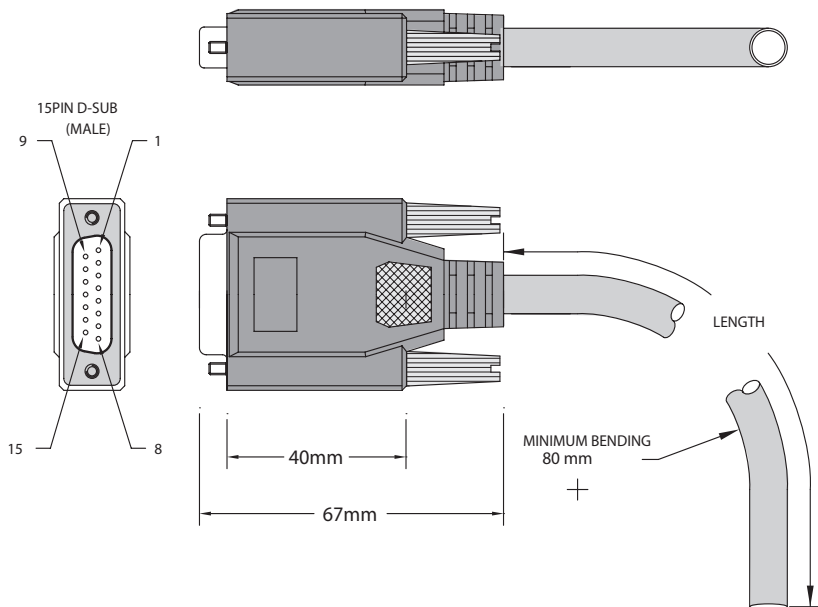

OVERVIEW
MOTOR SPECIFICATIONS
LINEAR SYSTEMS
CONNECTIVITY
PERIPHERALS
IP 65 MODELS & CONNECTIVITY
POWER SUPPLIES & SHUNTS
GEAR HEADS
SOFTWARE
APPENDIX

CAN Bus Flying Lead Cables, Right Angle Connector

The CAN FL1 cables are standard CAN bus communications cables rated to >1MB data transmission rate.

CBLIP series cables are sealed M12 threaded connector brass pins w/gold plating, maximum 4.0A 250V foil shield with black PVC jacket ~7.4mm dia.

Part Number	Description	Length
CBLIP-CAN-1MRA	Flying Lead Right Angle Connector	1 meter
CBLIP-CAN-3MRA	Flying Lead Right Angle Connector	3 meters
CBLIP-CAN-EXT-1M	CAN Bus Extension Cable	1 meter
CBLIP-CAN-EXT-2M	CAN Bus Extension Cable	2 meters
CBLIP-CAN-EXT-3M	CAN Bus Extension Cable	3 meters

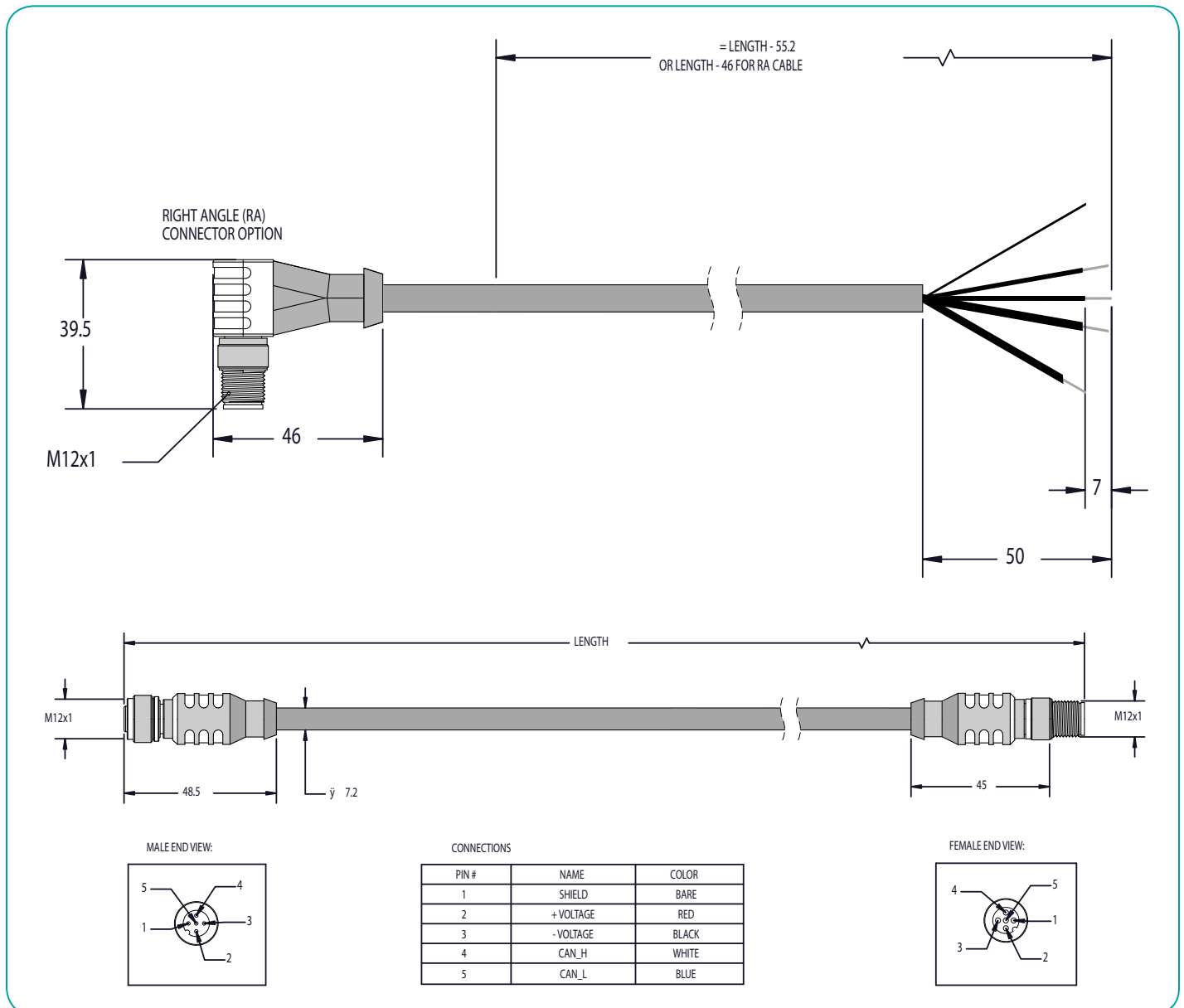

CAN Bus Y Cables, Right Angle Connector

The CAN Y1 series is meant for CAN bus communications connectivity between two motors with addition of a T-connector in line. Rated to >1MB data transmission rate.

This allows for cascading of multiple SmartMotor servos and the addition of a shunt resistor when required.

CBLIP series cables are sealed M12 threaded connector brass pins w/gold plating, maximum 4.0A 250V foil shield with black PVC jacket ~7.4mm dia.

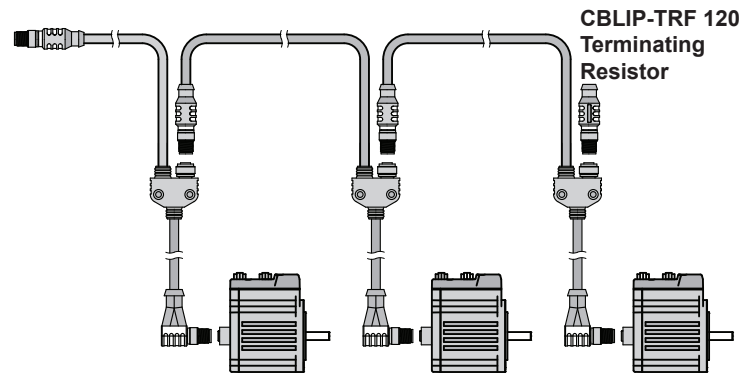

Right Angle Connector

Part Number	Length
CBLIP-CAN-Y1-0.5MRA	0.5 meters
CBLIP-CAN-Y1-1MRA	1 meters
CBLIP-CAN-Y1-3MRA	3 meters

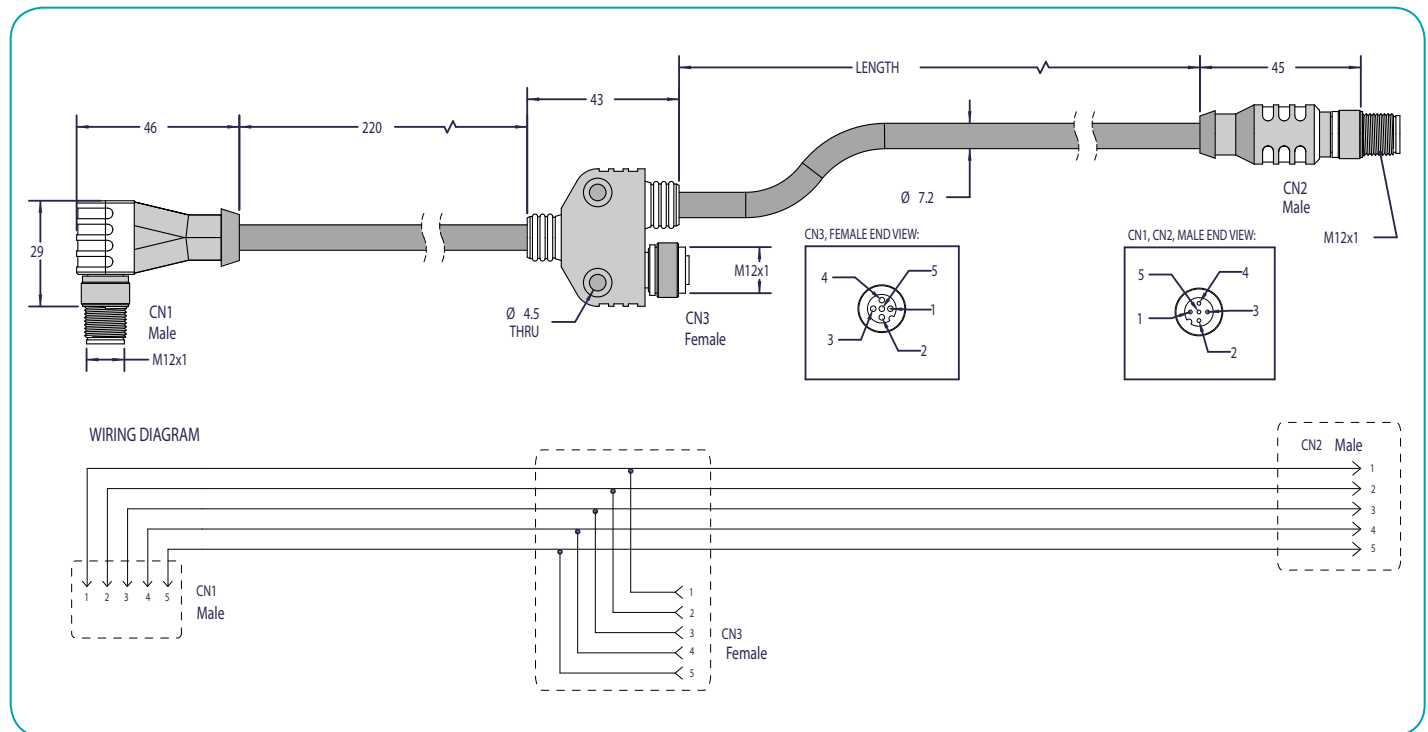

Note: At least one shunt resistor is required on ALL CAN bus networks. Please consult the factory for additional information.

CAN Bus T Connector and Shunts

OVERVIEW

MOTOR SPECIFICATIONS

LINEAR SYSTEMS

CONNECTIVITY

PERIPHERALS

IP 65 MODELS & CONNECTIVITY

POWER SUPPLIES & SHUNTS

GEAR HEADS

SOFTWARE

APPENDIX

"T" CONNECTOR FEMALE-FEMALE-MALE CBLIP-T-FFM

T connectors may be used in place of Y cables and in conjunction with CAN bus extension cables.

Shunt resistors **MUST BE** used to allow proper biasing of CAN Bus cables.

It is suggested to have at least one at furthest end of bus. Two may be required at opposing ends.

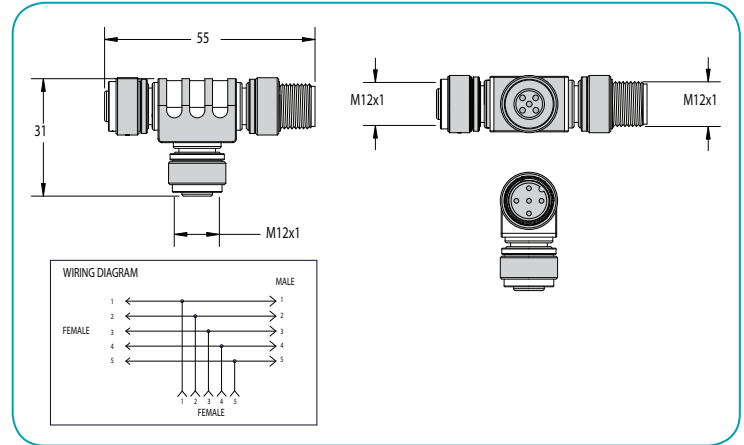

Female Terminating Resistor, 120 Ohms CBLIP-TRF120

Shunt resistors **MUST BE** used to allow proper biasing of CAN Bus cables.

It is suggested to have at least one at furthest end of bus. Two may be required at opposing ends.

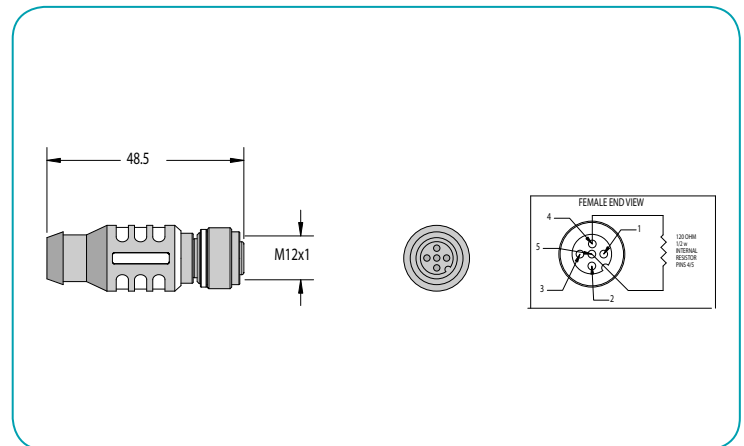

Male Terminating Resistor, 120 Ohms CBLIP-TRM120

Shunt resistors **MUST BE** used to allow proper biasing of CAN Bus cables.

It is suggested to have at least one at furthest end of bus. Two may be required at opposing ends.

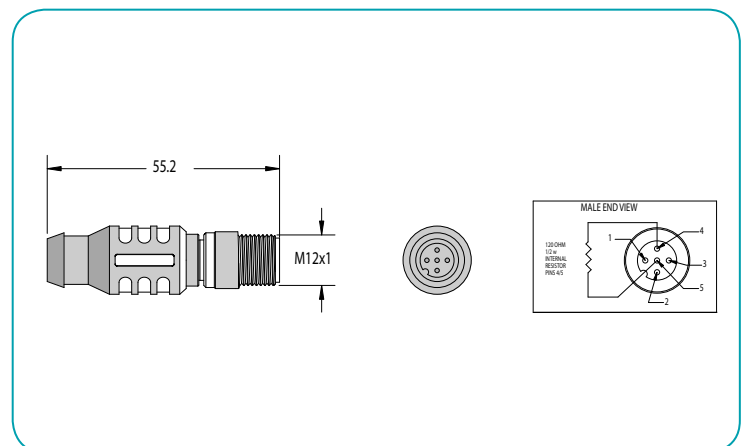

Note: At least one shunt resistor is required on ALL CAN bus networks. Please consult the factory for additional information.

Expanded I/O Cables for Non Sealed Motors W/-ADI Option

CBLIO-IO 24VDC TTL I/O Cable

The Expanded I/O cables are for use with the -AD1 expanded I/O option on all Class 5 non sealed SmartMotor™ servos. Each cable is a 12 conductor shielded cable. 2 conductors are for +24VDC I/O power. The other 10 are for 10 channels of I/O.

CBLIP series cables are sealed M12 threaded connector brass pins w/gold plating, maximum 4.0A 250V foil shield with black PVC jacket ~7.4mm dia.

Part Number	Description	Length
CBLIP-IO-FL-1MRA	Flying Lead Right Angle Connector	1 meter
CBLIP-IO-FL-3MRA	Flying Lead Right Angle Connector	3 meters
CBLIP-IO-EXT-1M	I/O Extension Cable	1 meters
CBLIP-IO-EXT-2M	I/O Extension Cable	2 meters
CBLIP-IO-EXT-3M	I/O Extension Cable	3 meters

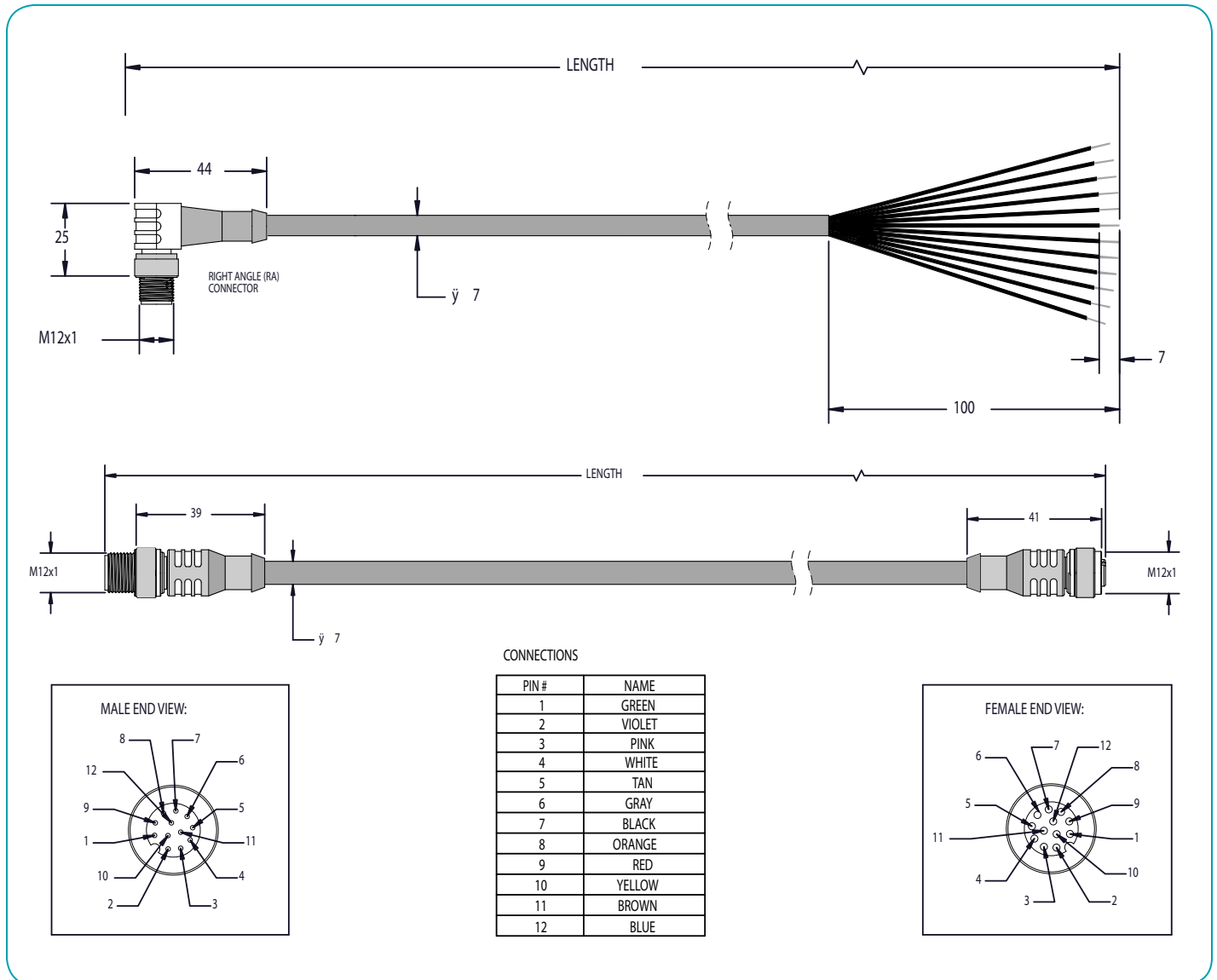

CBLSM1-X-Y-Z (Animatics Custom Build-to-Order)

Custom Multi-Motor Power and Communications Daisy Chain Cable for Networking Power and Communications to Multiple Animatics SmartMotor Servos

These cables are made to order where:

X = Cable length in Feet from the first motor to the Power and Serial connectors

Y = Number of Motors

Z = Distance in feet from one motor to the next

Note: This part numbering system does not allow for different length between each motor daisy chain network. The RS-232 Communications lines are in a separate shielded cable from the main power cable for optimum noise immunity.

Example:

CBLSM1- 10- 3- 5 would give you a 3-motor cable with 10 feet to the first motor and 5 feet between each motor.

Example of 3-Motor CBLSM1-X-Y-Z shown

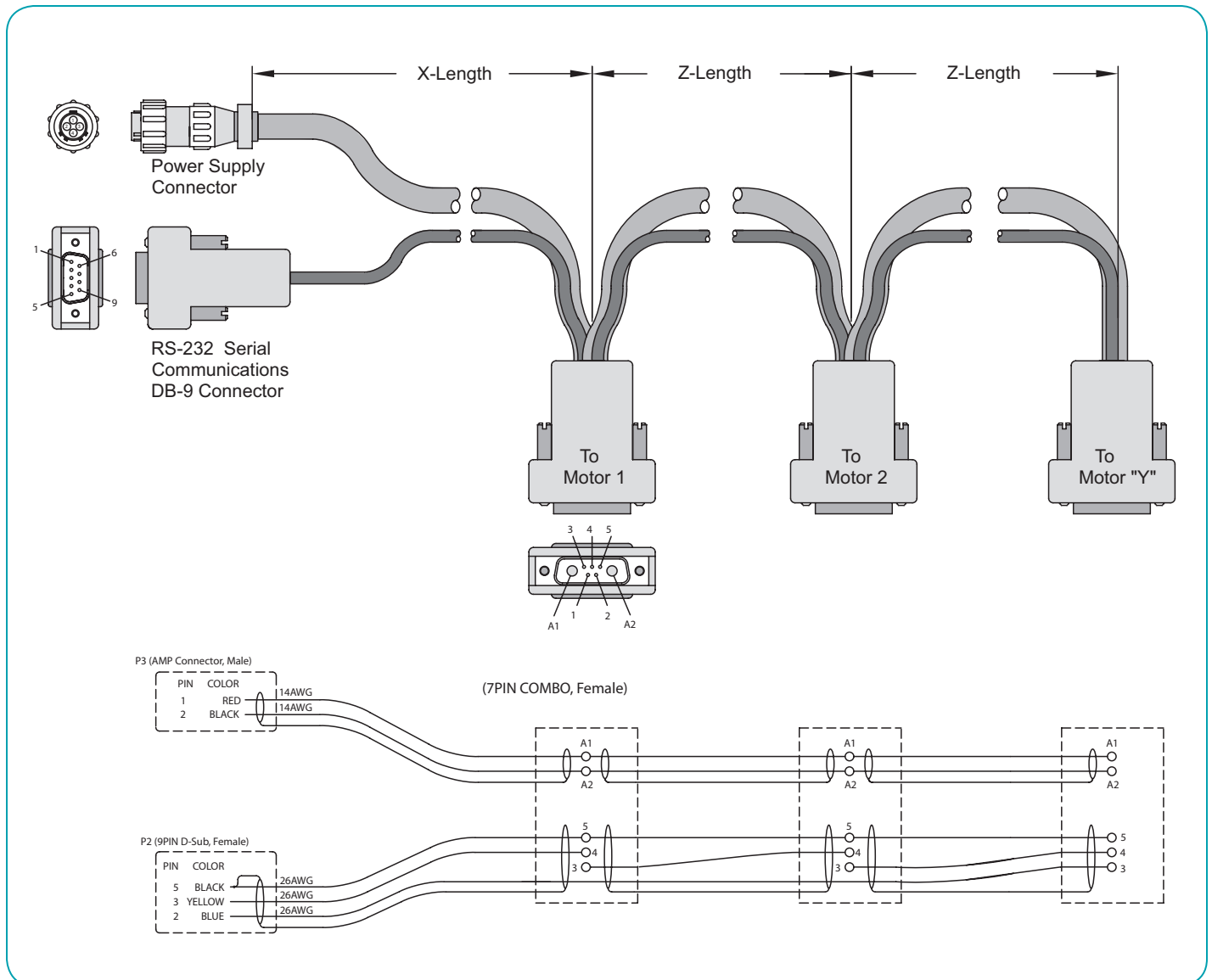

CBLSM2-X-Y-Z (Custom Build-to-Order)

Isolated RS-485 Multi-Drop Custom Cable

This cable makes use of the RS232485 converter at the host and a single RS485-ISO adapter at each motor.

The adapters have power hard wired and RS-485 wired together via jumper cables with a 4 pin G-grid Molex connect at each end.

As a result, it is easy to add or remove a given motor on the bus for setup and troubleshooting.

Since the RS485-ISO adapters are used, the entire Bus is isolated and shielded for maximum noise immunity in electrically harsh environments.

These cables are made to order where:

X = Cable length in Feet from the first motor to the Power and Serial connectors

Y = Number of Motors

Z = Distance in feet from one motor to the next

Note: This part numbering system does not allow for different length between each motor daisy chain network.

Example:

CBLSM2- 10- 3- 5 would give you a 3-motor cable with 10 feet to the first motor and 5 feet between each motor

Note: At least one shunt resistor is required on ALL CAN bus networks. Please consult the factory for additional information.

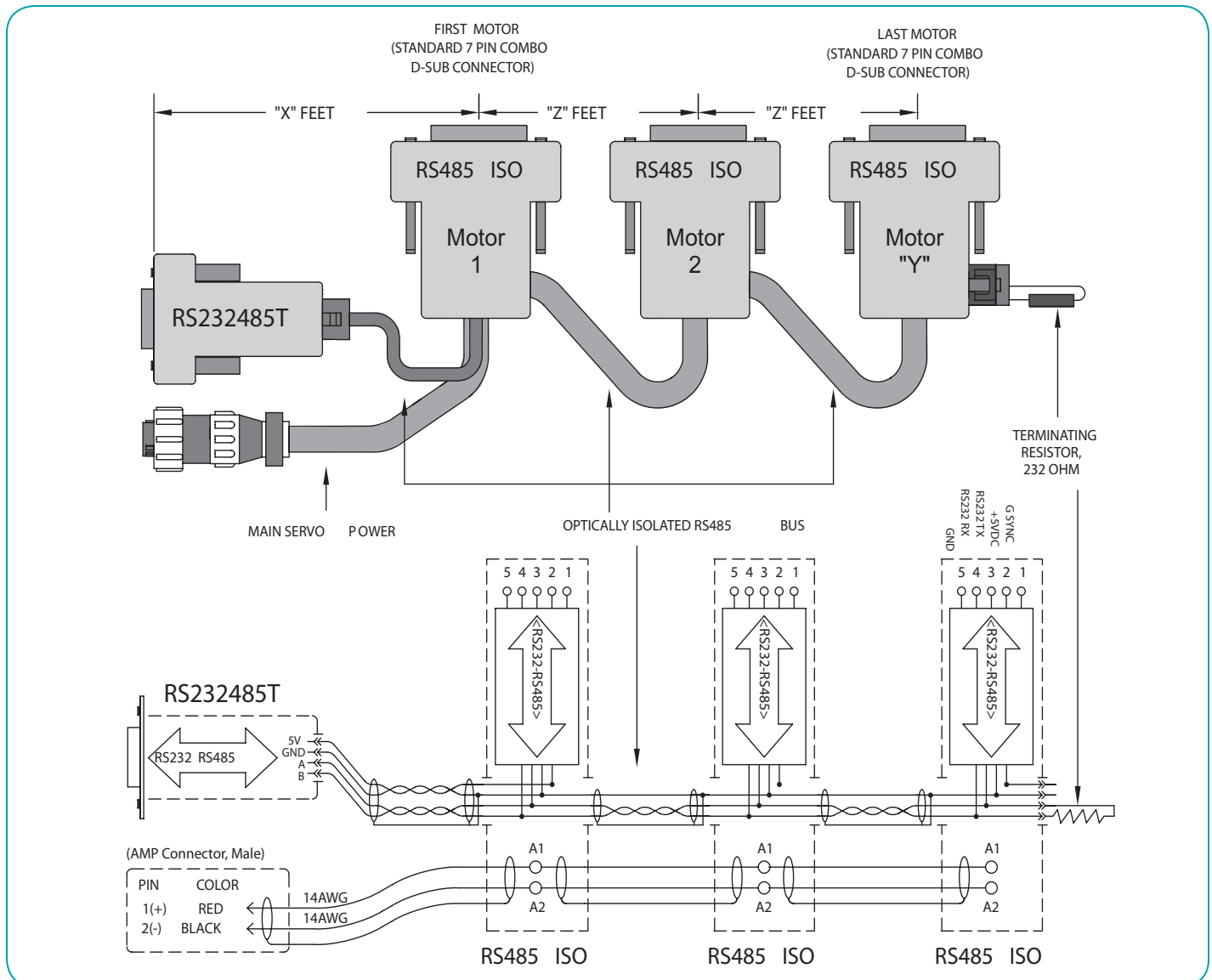

RS485-ISO

The RS485-ISO adapter provides electrically isolated conversion from RS-232 on the main 7W2 connector to RS-485. The adapter comes standard with a 10 Foot power cable and two parallel 4 pin Molex RS-485 connectors.

RS-485 provides improved noise immunity over cable lengths of up to 1,000 ft (305m). It also allows you to operate a network of up to 100 SmartMotor servos in parallel, rather than daisy-chaining the communications from one motor to the next.

The adapter draws power and ground from the SmartMotor main connector (pins 2 and 5). It does require the use of the main connector G-Synch line (pin 1) for Read-Write control of the 485 transceiver.

The RS485-ISO communications adapter can be ordered with or without the power cable (no cable P/N: RS485ISO-NOCBL).

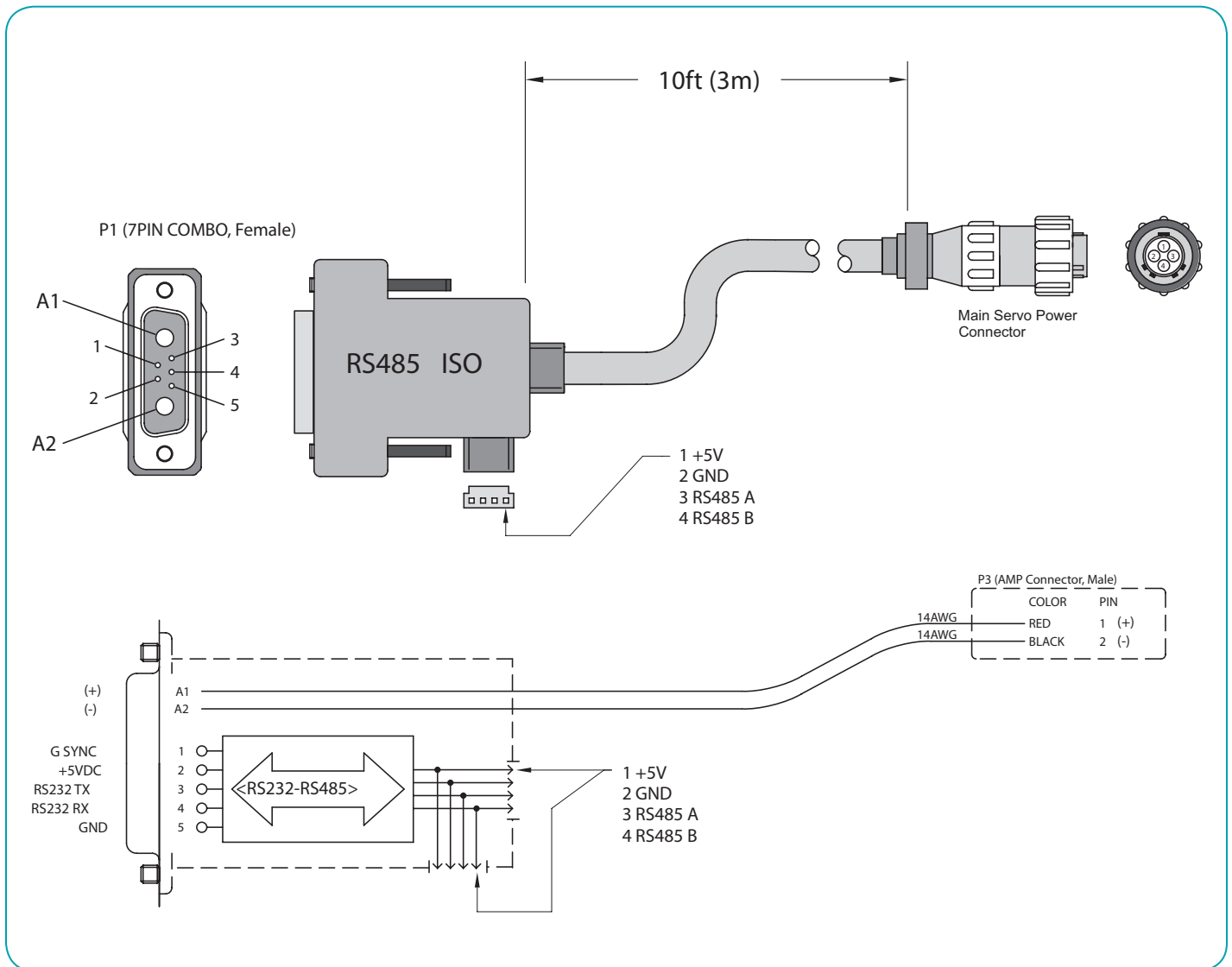

CBLSM1-DEMO

Training/Testing Power and Communications Cable for Main 7W2 Connector on Animatics SmartMotor™.

CBLSM1-Demo cable is only available in a fixed length of ~1 Meter. Similar to the CBLSM1-xM series, it consists of a 7W2 main motor connector split out to a pre-wired RS-232 DB-9 connector to plug directly into any standard PC serial port. The power to the motor is provided via a single 5mm diameter 2.1 mm center pin DC connector.

This connector accepts our PWR116V 24VDC power supply.

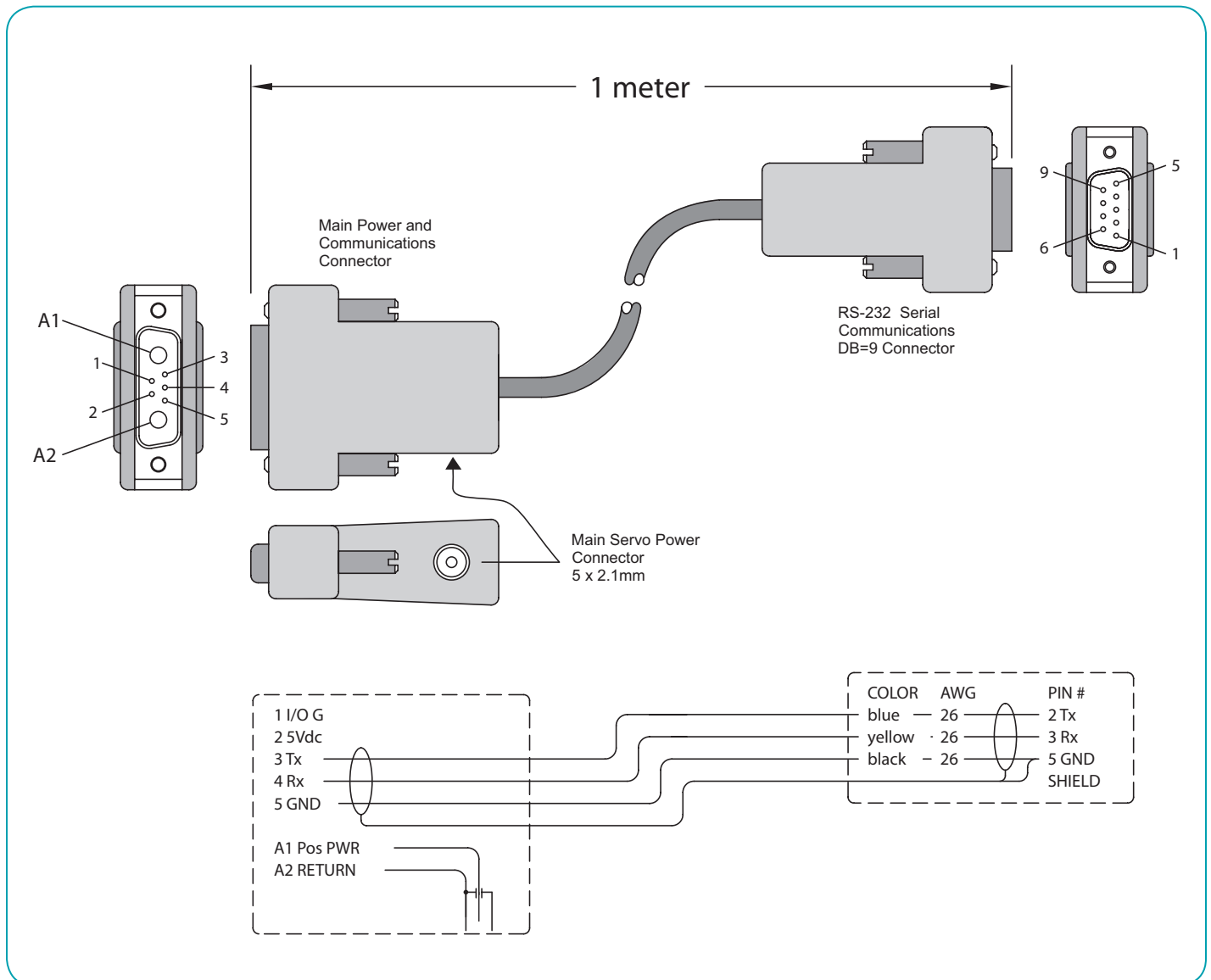

RS232485T

RS232485T is a non-isolated RS-232 to RS-485 communications adapter. It requires no drivers because it is hardware based only. The DB-9 connector can be plugged directly into a standard PC Serial port allowing the user to easily connect to and communicate with RS-485 devices.

Note: The 4-pin molex connector is designed to match the RS485ISO adapters below.

The connector can be removed to allow direct screw terminal connection as well.

Includes two KITDC3

(Proper RS-485 biasing must be used)

PIN#	FUNCTION:
1	5VDC
2	GND
3	RS485 A
4	RS485 B

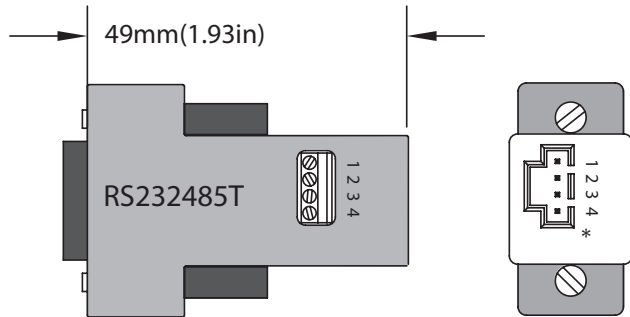

KITUSB232485

USB232485 is a non-isolated USB to RS-232 and RS-485 adapter. Available with Windows 98/2K/XP/Vista drivers.

This adapter plugs into standard USB port and provides either RS-232 or RS-485 communications. It is provided with ~1Meter standard USB cable.

Note: This is a single port device, it does not facilitate the use of both RS-232 AND RS-485 at the same time.

(Proper RS-485 biasing must be used in accordance with manual.)

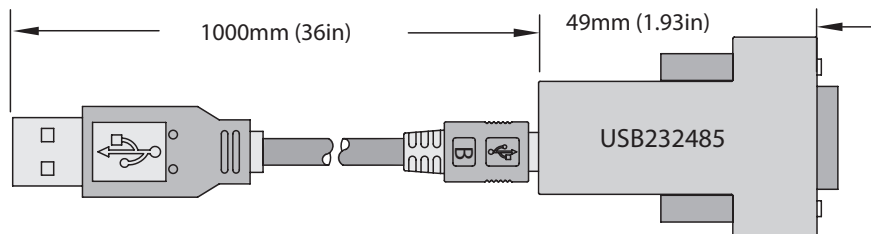

PIN#	FUNCTION:
1	RS485 A
2	RS232 Rx
3	RS232 Tx
4	+5Vdc
5	GND
9	RS485 B

New User Development Kits & Connectors

SMDEVPACK-D

SMDEVPACK-D is the introductory development package for the Animatics SmartMotor™. It is highly recommended for first time users and developers alike.

SMDEVPACK-D includes:

- UG-SM: Animatics SmartMotor User's Guide
- CD-SMI: SMI (SmartMotor Interface) software CD
- CBLSM1-3M: Power-Communications Cable
- KITSMDC3: D-Sub Connector kit
- KITDC1: DC power supply connector kit

NOTE: Connector kits above include all parts below on this page with exception of KITDC3



KITSMDC3		
Part	Description	Qty.
CN132	Connector, Male, 15 Pin D-sub NOTE: for I/O Connector	1
P104	Pin Contact Contact Size 20 Crimp Type, 24-20 AWG	20
CN141	Connector, 7W2 Combination 7 Pin DB-15 Shell Size 2	1
CN142	Socket Contact Solder Cup 14 AWG for 7W2 Combo Connector	2
CN149	Connector Hood For DB-15 Shell Size, EMI/Magnetic Shielded	1
P121	Pin Contact, Female Contact Size 20 Crimp Type, 24-20 AWG	20
CN121V	Connector, Female 9 Pin D-Sub	1
CN161	Connector Hood For DB-9 Shell Size EMI/Magnetic Shielded	2

KITDC1		
Part	Description	Qty.
CN114	Connector Shroud/Hood	1
CN119	4-Pin Connector NOTE: For enclosed Power Supplies & Shunts	1
P102	Pin, Crimp Type, Male 16-18AWG	4

KITDC3		
Part	Description	Qty.
KITDC3	4-Pin Molex Communication Connector Kit NOTE: Includes 4 female crimp pins	1

DINIO7

The **DINIO7** is a DIN Rail mount adapter that allows the Animatics SmartMotor™ to easily interface with popular Input/Output blocks like those produced by Gordos, Grayhill, OPTO-22™ and other manufacturers.

The DINIO7 has slots for seven industry standard OPTO Modules and can be used with either input or output modules.

The DINIO7 has a 9 pin connector for direct connection to a personal computer serial RS232 communications port and an AniLink™ network connector. It is also equipped with an expansion bus to allow it to interface with other Animatics DIN rail mount adapters. Wiring Input/Output up to your Animatics SmartMotor™ is made simple with the DINIO7 breakout board.

* Please consult with appropriate manufacturer for details

Cross Reference To Compatible Opto Modules

Mfg.*	DC Input	DC Output	AC Input	AC Output
Opto-22	G4-IDC5	G4-ODC5	G4-IAC5	G4-OAC5A
Grayhill	70G-IDC5	70G-ODC5A	70G-IAC5A	70G-OAC5A
Crydom	X4IDC5	X4ODC5	X4IAC5	X4OAC5
Gordos/ Crouzet	C4-IDC5	C4-ODC5	C4-IAC5	C4-OAC5
	(3-32VDC high side)		(120VAC high side)	

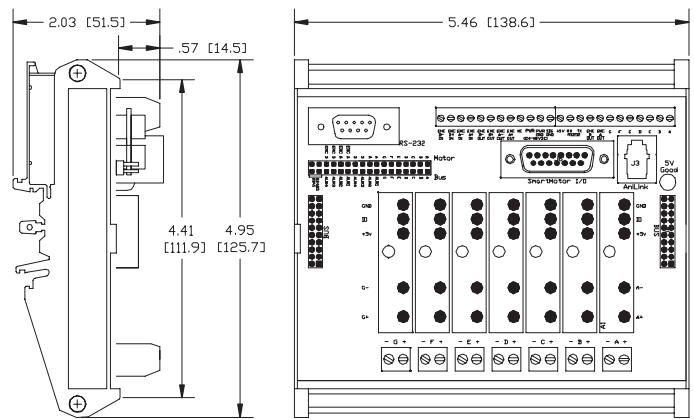
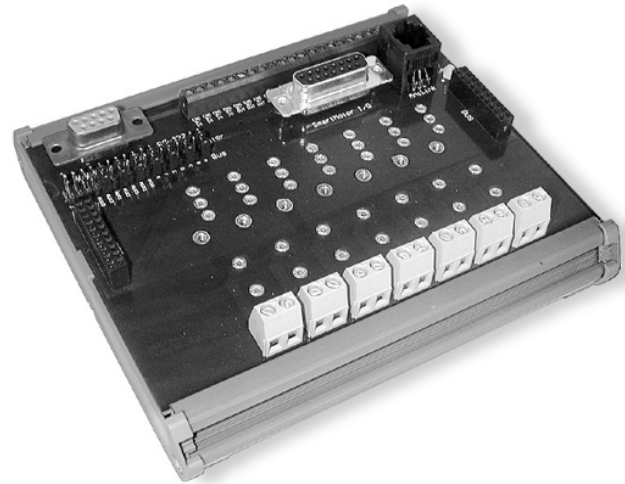

* All sizes are given in inches, sizes in brackets are in mm

Features

Benefits

DB-15 or screw terminal access to your SmartMotor	Easy connection for panel environment
AniLink port for expansion to other AniLink devices	Cascadable
7 main I/O buses to cross connect I/O to other motors	Flexible use
Aux buses to interconnect encoders between motors	Simplifies encoder connections
Jump-in RS485 terminal resistors	No added parts necessary for RS485 termination
On board DB-9 for fast RS232 access	May be used with standard RS232 extension cables

DIN-RS232

The **DIN-RS232** is a DIN Rail Mount breakout for the OEM and Legend Series RS232 communications. It allows a single Master to communicate with up to eight Animatics SmartMotors over RS232 without the loss of bandwidth typical of daisy chain propagation. Since this operation is nearly identical to the operation of an RS485 bus, the DIN-RS232 can also accommodate an RS485 master.

The DIN-RS232 master communications circuitry can take its power from any industry standard 24VDC power supply. The eight communications links to each of the Animatics SmartMotor™ breakouts are electrically isolated from the master, and are individually powered by its associated SmartMotor. This isolation can be critical to reliable systems where there may be ground bounce in the power runs between the motors.

The DIN-RS232 is able to transmit simultaneously to eight SmartMotors because all of the links are in parallel. This means that the eight transmit and receive lines are functionally tied together. For this reason, the user must treat the eight SmartMotors on this unit as if they were on a parallel communications bus, like RS485. While the user can transmit to all SmartMotors on the bus simultaneously, care must be taken to assure that no two SmartMotors reply at the same time. The DIN-RS232 also has a fused power bus to allow the convenient connection of SmartMotors to a central power input.

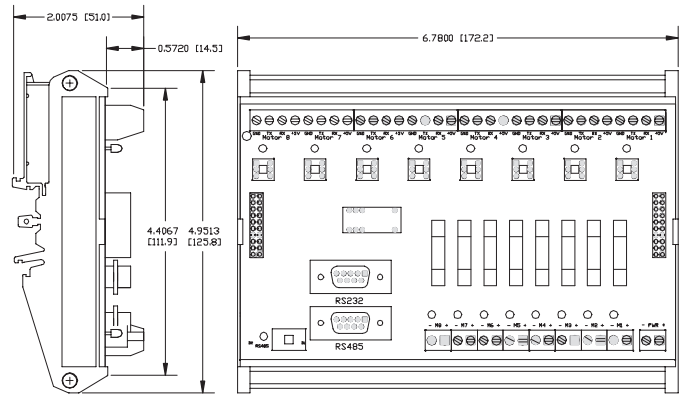
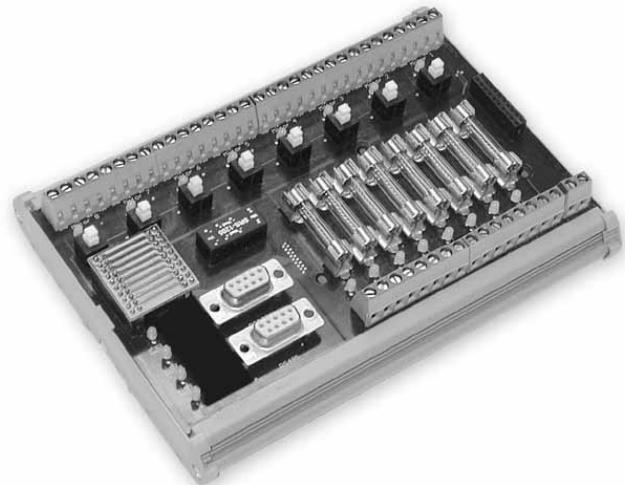

* All sizes are given in inches, sizes in brackets are in mm

Features

Benefits

Eight RS-232 communications ports
Isolated interface to eight SmartMotors without daisy chain propagation delay penalty.

Power bus
Fused interconnection to up to eight SmartMotors.

Selectable Master
Choose RS232 or RS485 to be the communications Master

Electrical

Power bus line voltage: 19V to 48VDC
Isolated communications bus power: 4.5V to 5.5V, 35 mA

Animatics OPTO2 — 16 Channel Opto-isolator Board

Optically isolates and converts signals between:

5VTTL logic and 24VDC Control Logic Systems

- 8 Input Channels
- 8 Output Channels
- Red Fail-Safe LED Indications
- Plug-in connectors
- DIN Rail Mount
- Only 0.84 Inches of rail space
- Shunt Diode protection for Inductive loads

5VDC Logic Side:

- Darlington Output Sinking
- 6.8VDC max input
- 120mA Max. 5VDC Load

24VDC Control Side:

- Darlington Output Sourcing
- 12 to 32VDC Working Range
- 120mA Max. Load @24VDC

Timing:

- 100 μ Second On/Off max.
- Max. continuous throughput: 250KHz @50% duty cycle square wave.

Sample Schematic of Inputs and Outputs:

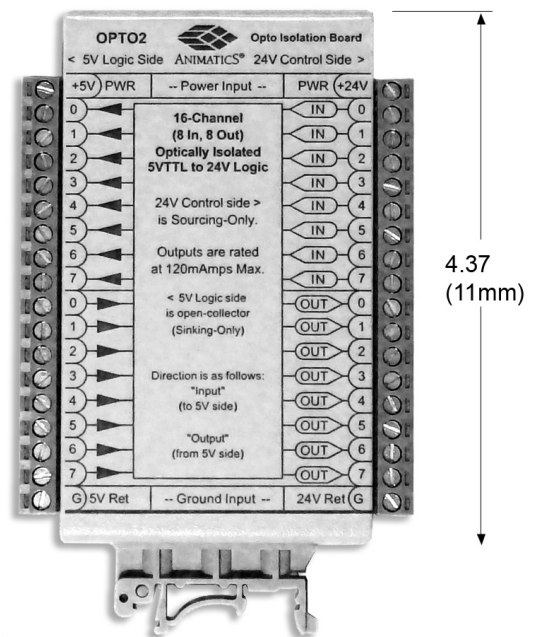
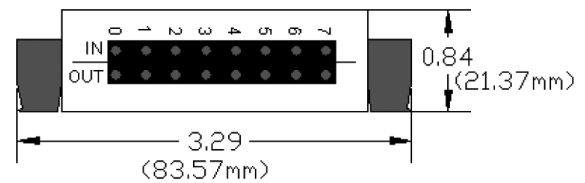
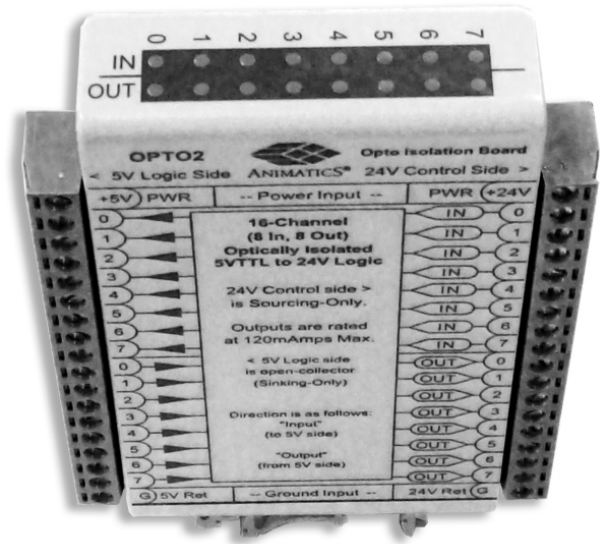
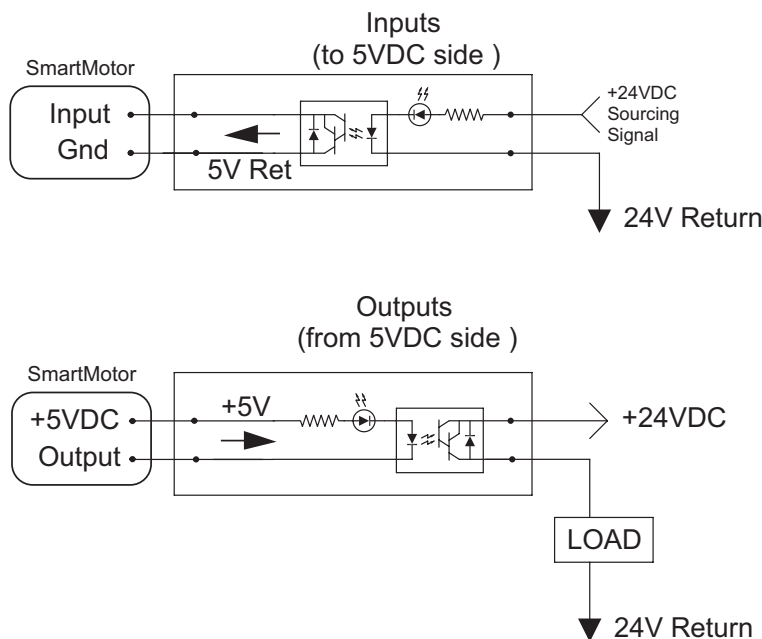

Notes



OVERVIEW
MOTOR SPECIFICATIONS
LINEAR SYSTEMS
CONNECTIVITY
PERIPHERALS
IP 65 MODELS & CONNECTIVITY
POWER SUPPLIES & SHUNTS
GEAR HEADS
SOFTWARE
APPENDIX

SmartBox™: The Handheld Diagnostics and Testing Interface is designed as an aid in test and development of Animatics SmartMotor™ applications. The SmartBox™ is small and compact in size but it offers big returns in convenience and time savings. Its portability and simple operation make it ideal for use at remote locations to run SmartMotor™ functions and for onsite testing.

The SmartBox Hardware consists of:

- Two-Color LED connected to Port C Output can be programmed for 3 states: OFF, ON (Green), or ON (Red)
- Three Position Toggle Switch (Go)-Off-(Sel.) spring return to center
- Analog Input Potentiometer Connected to Port D
- External Encoder Input w/1000 line encoder
- 4 Red LEDs, in two sets wired reverse parallel to Ports E and F to allow for any or all to be turned on or off.
- Cable with 15 pin D-sub I/O connector
- Power Input Jack on side (2.1x5mm)



Sample SmartMotor™ program available:

Select from a variety of pre-programmed modes using the Selector switch w/LED indication of Mode corresponding to the label on the side of the unit. This program allows simulation of the following:

- Mode Follow at 1:1 counts V following Encoder Knob
- Position Mode (Adjustable absolute commanded position)
- Velocity Mode (Continuously variable, bi-directional)
- Torque Mode (Continuously variable, bi-directional)
- Relative Mode (Adjustable distance)
- Fast Indexing (Self triggered with adjustable distance and dwell)
- Cam Mode
- Variable Gearing (Continuously adjustable gear ratio)
- Preset Moves (Pre-programmed multi-move profiles)

The SmartBox can test and demonstrate the following hardware connections including:

- Analog input
- Digital I/O
- Step and direction Input
- Encoder I/O

Note: Demonstration Program available for download at www.animatics.com.

Side and Back Cover Labels:

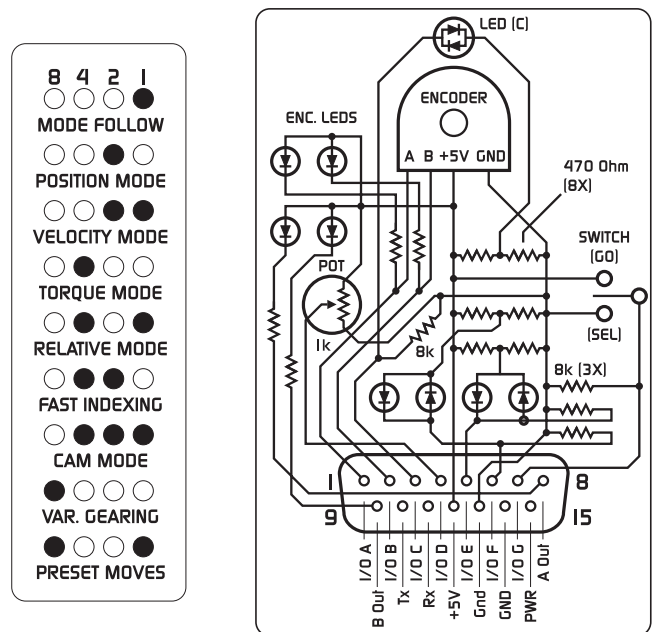

Mode Indicator Legend and schematic are printed on the SmartBox for easy reference

SmartBoxBCD™: Designed for use with SmartSelect™ Software, the Handheld Diagnostics and Testing Interface is similar to standard Animatics SmartBox, but is geared towards PLC I/O handshake simulation. It is intended for use as a means to simulate 5 inputs from a PLC and 2 outputs back to the PLC to aid in development of applications where only On/Off I/O triggering is used to control the SmartMotor™.

The SmartBoxBCD Hardware consists of:

- Two Bi-Color LEDs; one each connected to Ports E and F. Each can be set one of three states: OFF, ON (Green), or ON (Red)
- Five Three-Position Toggle Switches (On)-Off-(Momentary-On.) where center position is off. Connected to Ports A, B, C, D, and G
- Cable with 15 pin D-sub I/O connector
- Power Input Jack on side (2.1x5mm)



When Used with SmartSelect™ Software:

The SmartBoxBCD interface simulates:

- 4-bit binary Input from a PLC on ports A, B, C, and D
- “Go” input from a PLC on Port G
- Busy Output to PLC on Port E
- Fault Output to PLC on Port F

When the Motor receives a “Go” signal, the program responds to 1 of 16 preset move profiles as determined by the 4-bit binary input state of Ports A, B, C, and D. While moving, the “Busy” LED is Red, once done, it switches to Green. If a Fault occurs, the Fault LED switches from Green to Red.

The SmartBoxBCD allows complete set-up and test of a SmartMotor™ in conjunction with the Point-And-Click SmartSelect™ Programming Tool. In doing so, the entire Servo Control of a system can be set up and tested prior to PLC Programming or I/O connections. As a result, machine development time is reduced to a minimum.

Back Cover Label Shows internal Schematic:

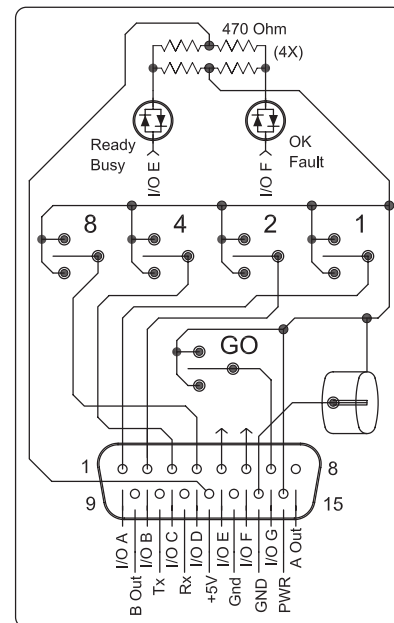

OVERVIEW
MOTOR SPECIFICATIONS
LINEAR SYSTEMS
CONNECTIVITY
PERIPHERALS
IP 65 MODELS & CONNECTIVITY
POWER SUPPLIES & SHUNTS
GEAR HEADS
SOFTWARE
APPENDIX

SmartMotor™ Series	SM34165MT-IP	
Continuous Torque @ 48V	12.58	in-lb
	201	oz-in
	1.42	N-m
Peak Torque	21.57	in-lb
	345	oz-in
	2.44	N-m
Nominal Continuous Power	448	Watt
	0.45	kW
	0.60	HP
No Load Speed	5,100	V/kRPM
Continuous Current @ Nominal Power	15.5	Amps
Voltage Constant	8.9	V/kRPM
Winding Resistance	0.06	ohms
Encoder Resolution	8000	Counts/Rev
Rotor Inertia	0.0142	oz-in-sec ²
	10.031	10 ⁻⁵ kg-m ²
Weight	6.0	lb
	2.72	kg
Shaft Diameter	0.50	in
	12.70	mm
Shaft, Radial Load	30	lb
	13.61	kg
Shaft, Axial Thrust Load	3	lb
	1.36	kg
DeviceNet Version	SM34165MT-IP-DN	
CANopen Version	SM34165MT-IP-C	



**IP67
Rated
Optional**



All New Class 5 Features and IP65 rated

- Complete barrier against dust and other harmful particles
- Longer motor life
- Splash protected* for wet environments unlike drip-proof competitors
- New industry capabilities such as food and beverage manufacturing and packaging, demanding outdoor conditions, and nautical machinery

* Not submersible

Animatics SmartMotor SM34165MT (No Options) CAD Drawing

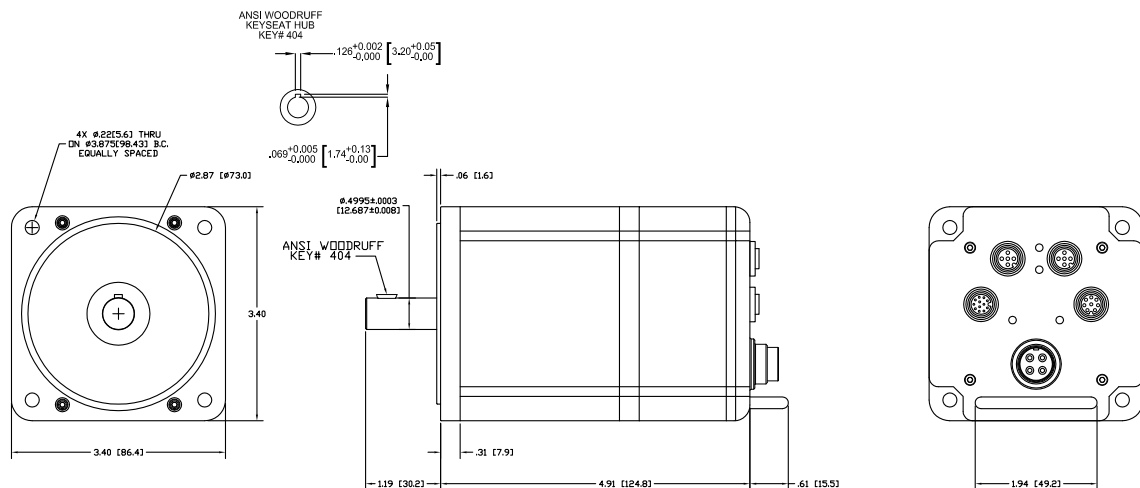

NOTE: Drive Power and Control Power are Separate Inputs. Control Power is rated to a maximum range of 18 to 32VDC. Drive Power is from 18 to 48VDC max.

IP 65 Models

With the release of Animatics' new IP65 rated SM34165MT-IP SmartMotor™, a wealth of new application possibilities have been exposed. This is the first harsh environment-rated product from Animatics, and the quality and durability of the SmartMotor integrated servo in combination with an IP65 rating (and an option for an IP67 rating) has added tremendous value to an already strong product series.



For the IP65 rated SmartMotor, not only is it completely dust tight but it's also protected from ingress of liquid that may occur from any angle, rendering no harmful effects on the electrical enclosure. The SM34165MT-IP can withstand splashing water, oil or food debris as well as rainy conditions. Conditions with high levels of humidity and condensation are no longer a problem. This makes the SM34165MT-IP with the IP65 rating the perfect integrated servo for food and beverage manufacturing and packaging, rugged outdoor conditions, as well as any wet processing environment.

In addition, the SM34165MT-IP has the option for upgrade to an IP67 rating. These products provide the same level of dust and particulate protection, with the added advantage of being submersible in water or other non-hazardous liquid

up to one meter deep for up to 30 minutes. From naval applications to watercraft to medical research, applications are endless for an IP65 and IP67 SmartMotor.

IP ratings are in accordance with the code defined in international standard IEC 60529. Instead of the vague descriptions of "waterproof", "water-resistant" or "dust-proof", the IP rating system provides a uniform, quantifiable set of standards to which each product is rigorously tested. The IP code refers to the degree of protection for the electrical enclosures on a machine against liquid, solid objects and particulates. The first number following "IP" refers to the level of protection of the hazardous parts and electrical enclosures against solid objects and particulates, and the second digit indicates the level of water resistance. The higher the first digit rating in the IP system, the smaller the foreign object that it is protected against. The SM34165MT is IP65 rated (with the option for IP67) and thus has the highest possible protection from solid matter: it is completely dust-tight. With this rating, any wood, concrete, wheat or grain, plaster or other material processing applications usually resulting in fine byproduct are completely accessible with the SM34165MT-IP.



Torque Curve

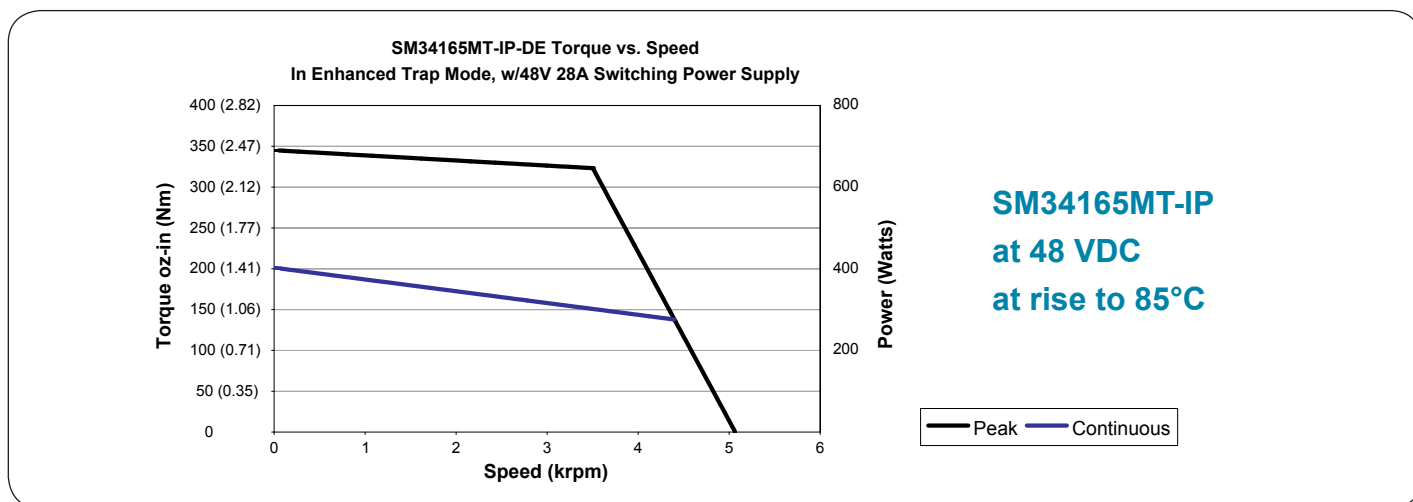

All torque curves were derived under dynamometer testing at an ambient temperature of 25°C with a heat rise of level shown for continuous curves. These are maximum values obtained for dyno tested torques as shown in the catalog which can be found at www.animatics.com.

Consult Factory or your nearest Automation Solution Provider (ASP) for Manual, Software and Accessories.

IP 65 Models

OVERVIEW

MOTOR SPECIFICATIONS

LINEAR SYSTEMS

CONNECTIVITY

PERIPHERALS

IP 65 MODELS & CONNECTIVITY

POWER SUPPLIES & SHUNTS

GEAR HEADS

SOFTWARE

APPENDIX

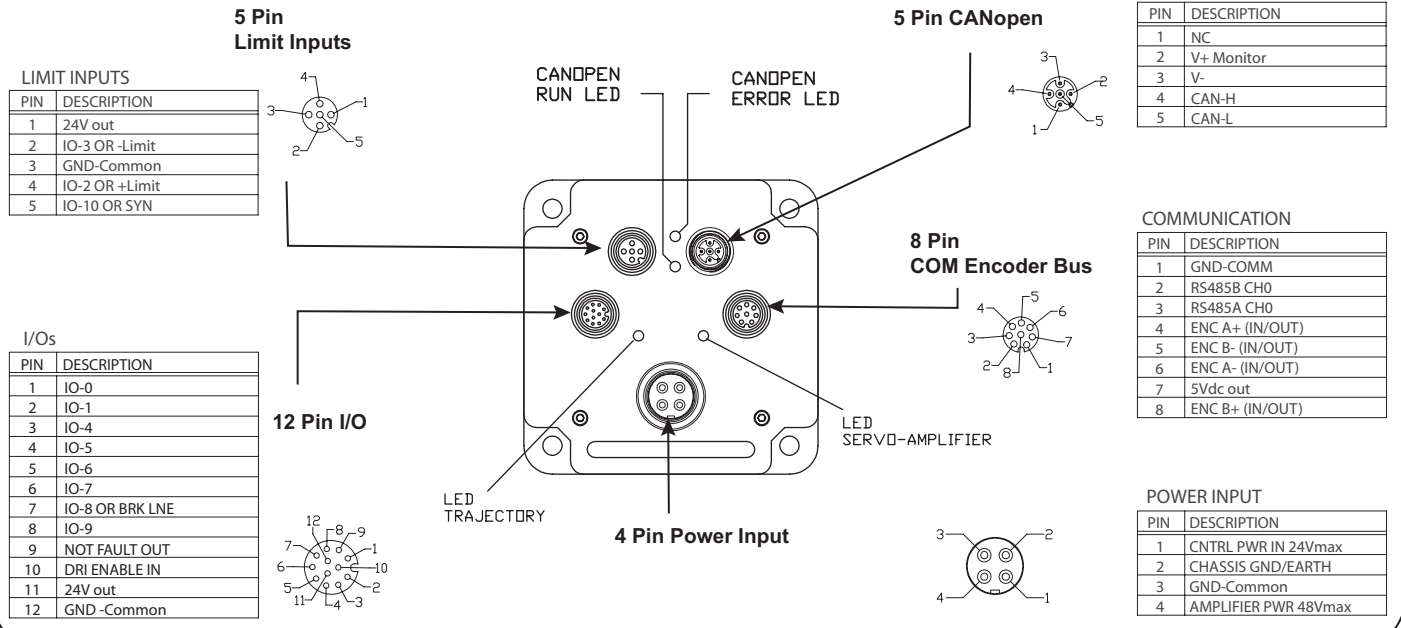

Note: LEDs operation for IP sealed motors is the same as described on p130 for standard motors.

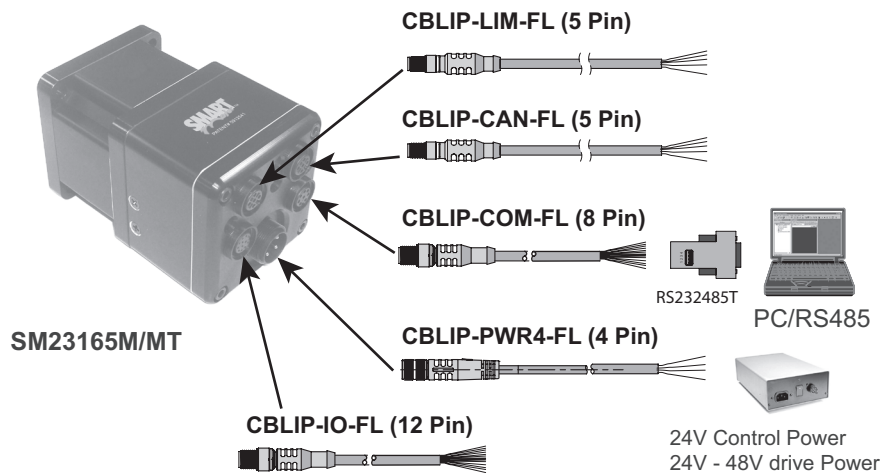
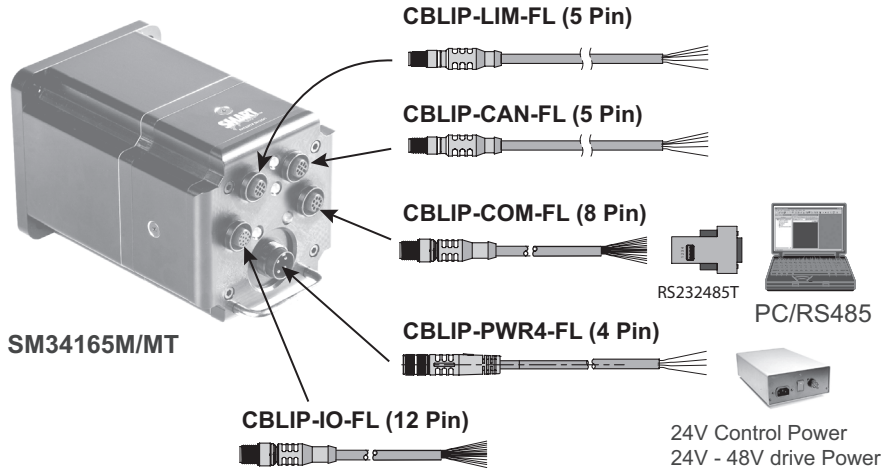

Class 5 Multi-Axis Connection Maps (IP 65 Sealed Models)

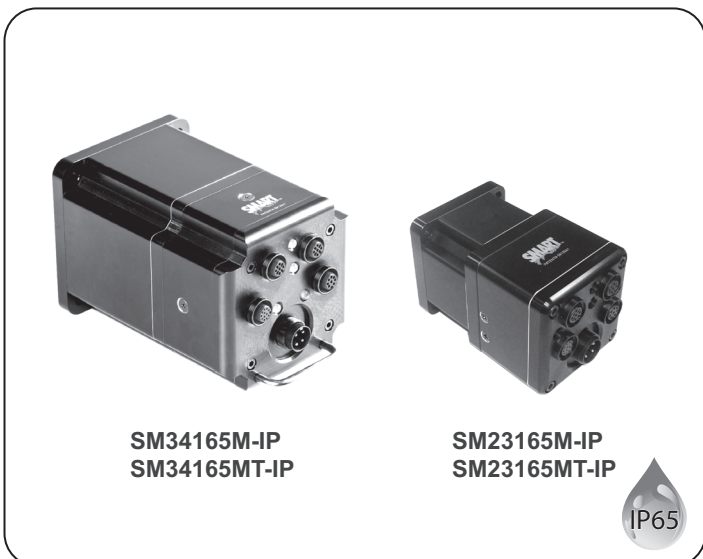
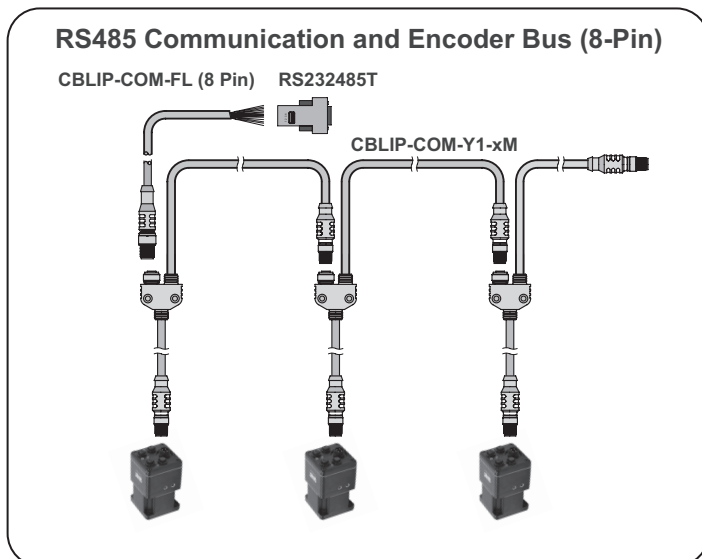
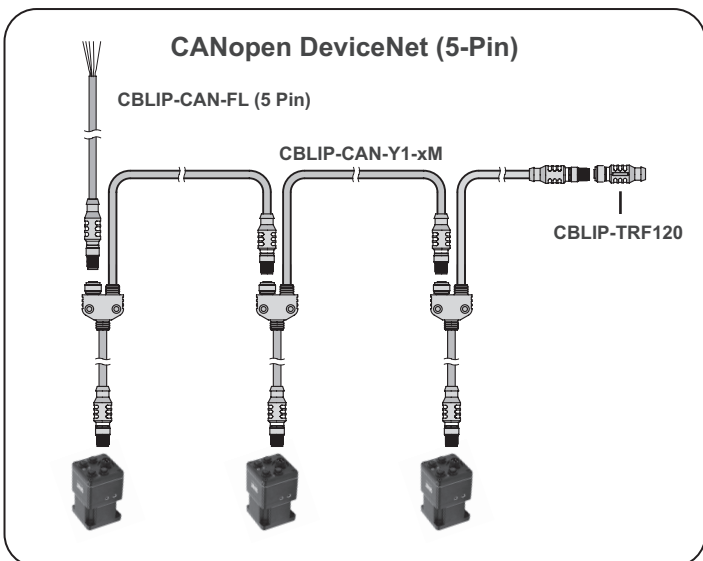
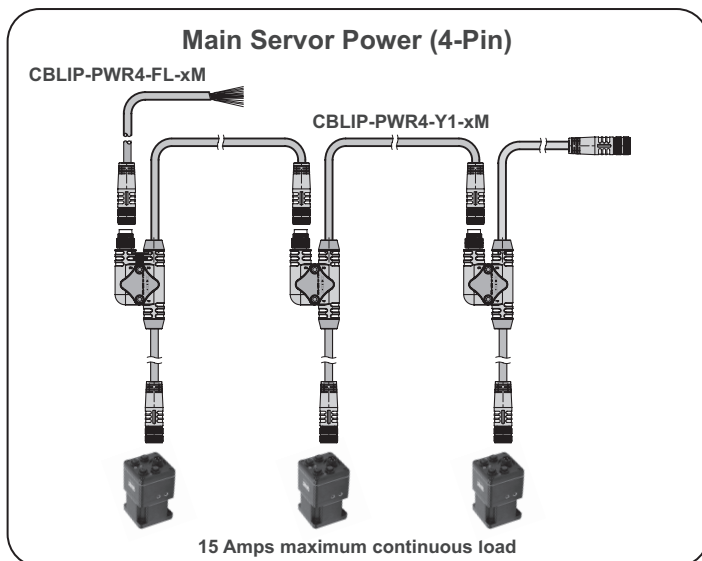

NOTE: Drive Power and Control Power are Separate Inputs. Control Power is rated to a maximum range of 18 to 32VDC. Drive Power is from 18 to 48VDC max.

PART NUMBER	DESCRIPTION
SM34165M	CANopen option (Standard)
SM34165M-IP	IP65 seal, CANopen option (Standard)
SM34165MT	CANopen option (Standard)
SM34165MT-IP	IP65 seal, CANopen option (Standard)
SM34165MT-DN	DeviceNet option
SM34165MT-IP-DN	IP65 seal (splash proof) and DeviceNet option
SM34165MT-IP67	IP67 seal (submersible) CANopen option (Standard)
SM34165MT-IP67-DN	IP67 seal (submersible) and DeviceNet option

Note: User can download their choice of CANopen or DeviceNet firmware from the Animatics website.

24V I/O and CAN or DN is Standard on all IP 65 sealed models

Drive and Control Power Cable

Main Power Input Cable supplies connection point to drive power and control power. This cable is required to power up all DC input sealed motors. Standard M16 threaded connector. Brass pins w/Gold Plating, Maximum 12.0A . Foil shield with Black PVC jacket ~7.4mm Dia.

Part Number	Description	Length
CBLIP-PWR-FL-1M	Flying Lead Strait Connector	1 meter
CBLIP-PWR-FL-3M	Flying Lead Strait Connector	3 meters
CBLIP-PWR-Y1-3MRA	Flying Lead Right Angle Connector	3 meters

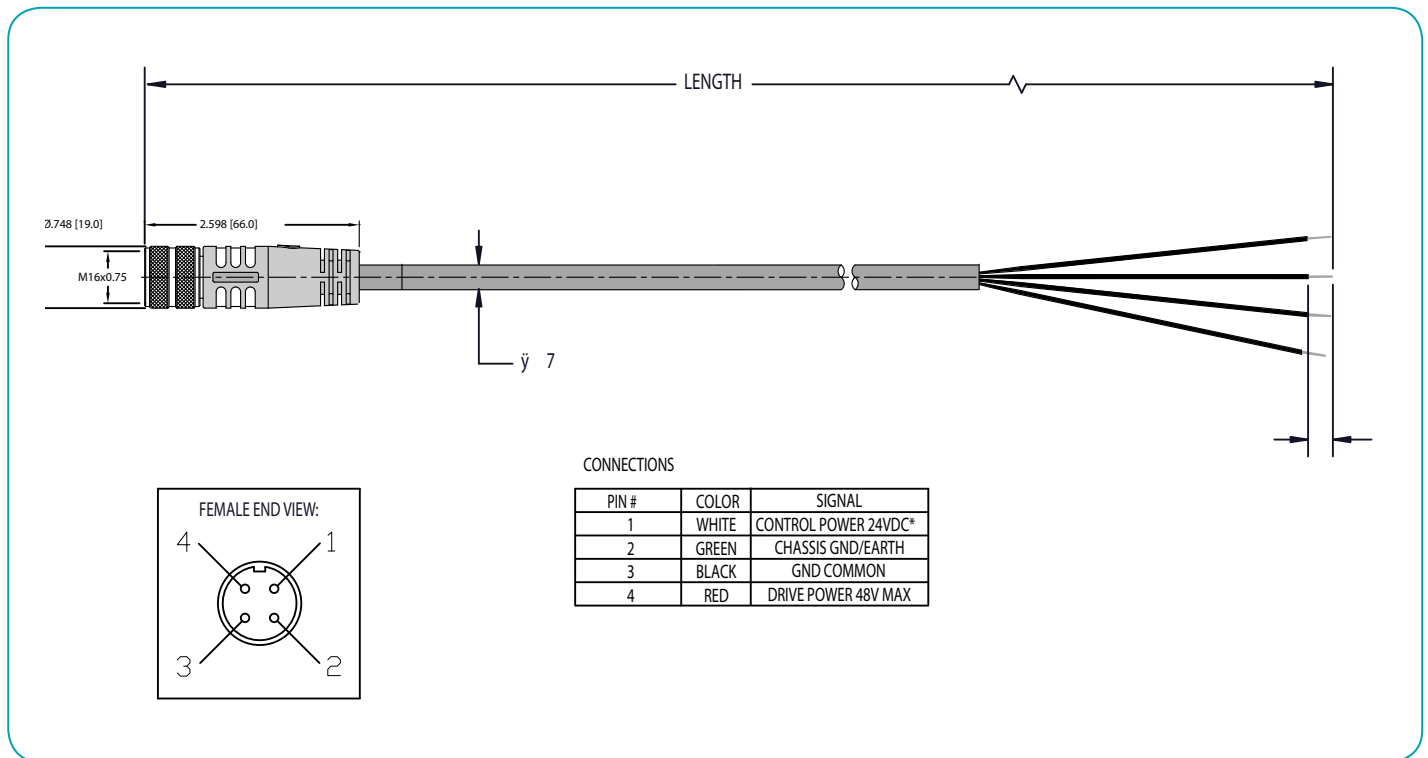

NOTE: Drive Power and Control Power are Separate Inputs. Control power is rated to a maximum range of 18 to 32VDC. Drive Power is from 18 to 48VDC max.

OVERVIEW
MOTOR SPECIFICATIONS
LINEAR SYSTEMS
CONNECTIVITY
PERIPHERALS
IP 65 MODELS & CONNECTIVITY
POWER SUPPLIES & SHUNTS
GEAR HEADS
SOFTWARE
APPENDIX

CBLIP-PWR4-1-xM (Animatics™ “Add-A-Motor™” Cable)

CBLIP-PWR4-Y1-xM Add-A-Motor cable for IP65 series motor Drive and Control Power Daisy chain cable for power distribution to multiple motors.

CBLIP-PWR4-Y1-xM series is the main power cable for IP65 motors featuring easy daisy chaining of both drive and control power to multiple motors.

This cable plugs into the M16 4 pin connector allowing split off to another cable and motor.

Part Number	Length
CBLIP-PWR4-Y1-0.5M	0.5 meters
CBLIP-PWR4-Y1-1.0M	1.0 meters
CBLIP-PWR4-Y1-3.0M	3.0 meters

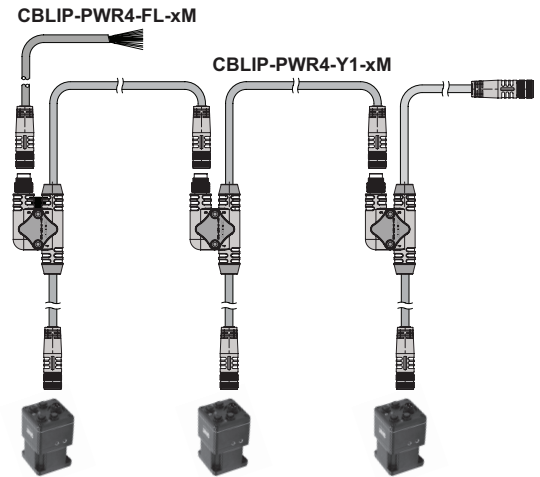

Note: Maximum of 15 Amps continuous RMS load per total daisy chain transmission line.

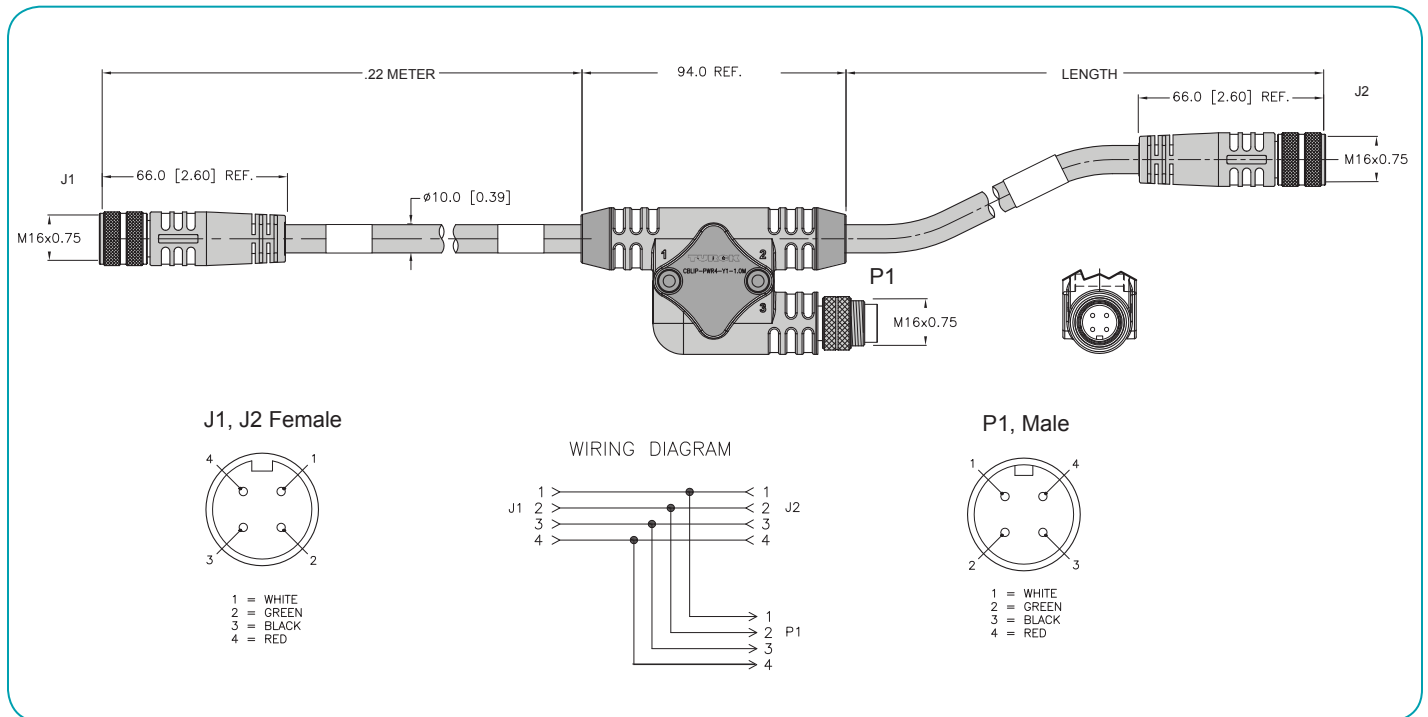

NOTE: Drive Power and Control Power are Separate Inputs. Control power is rated to a maximum range of 18 to 32VDC. Drive Power is from 18 to 48VDC max.

Communications and Encoder Bus Flying Lead Cable

This cable is required for basic communications to the main RS485 Port. The communications port also contains pins for the bi-directional encoder bus. Data rates rated to >1MHz. CBLIP-COM series cables are sealed M12 threaded connector, brass pins w / gold plating, maximum 2.0A. foil shield with black PVC jacket ~7.4mm dia.

Part Number	Description	Length
CBLIP-COM-FL-1M	Flying Lead Strait Connector	1 meter
CBLIP-COM-FL-3M	Flying Lead Strait Connector	3 meters
CBLIP-COM-FL-1MRA	Flying Lead Right Angle Connector	1 meter
CBLIP-COM-FL-3MRA	Flying Lead Right Angle Connector	3 meters
CBLIP-COM-EXT-1M	Comm. Extension Cable	1 meters
CBLIP-COM-EXT-2M	Comm. Extension Cable	2 meters
CBLIP-COM-EXT-3M	Comm. Extension Cable	3 meters

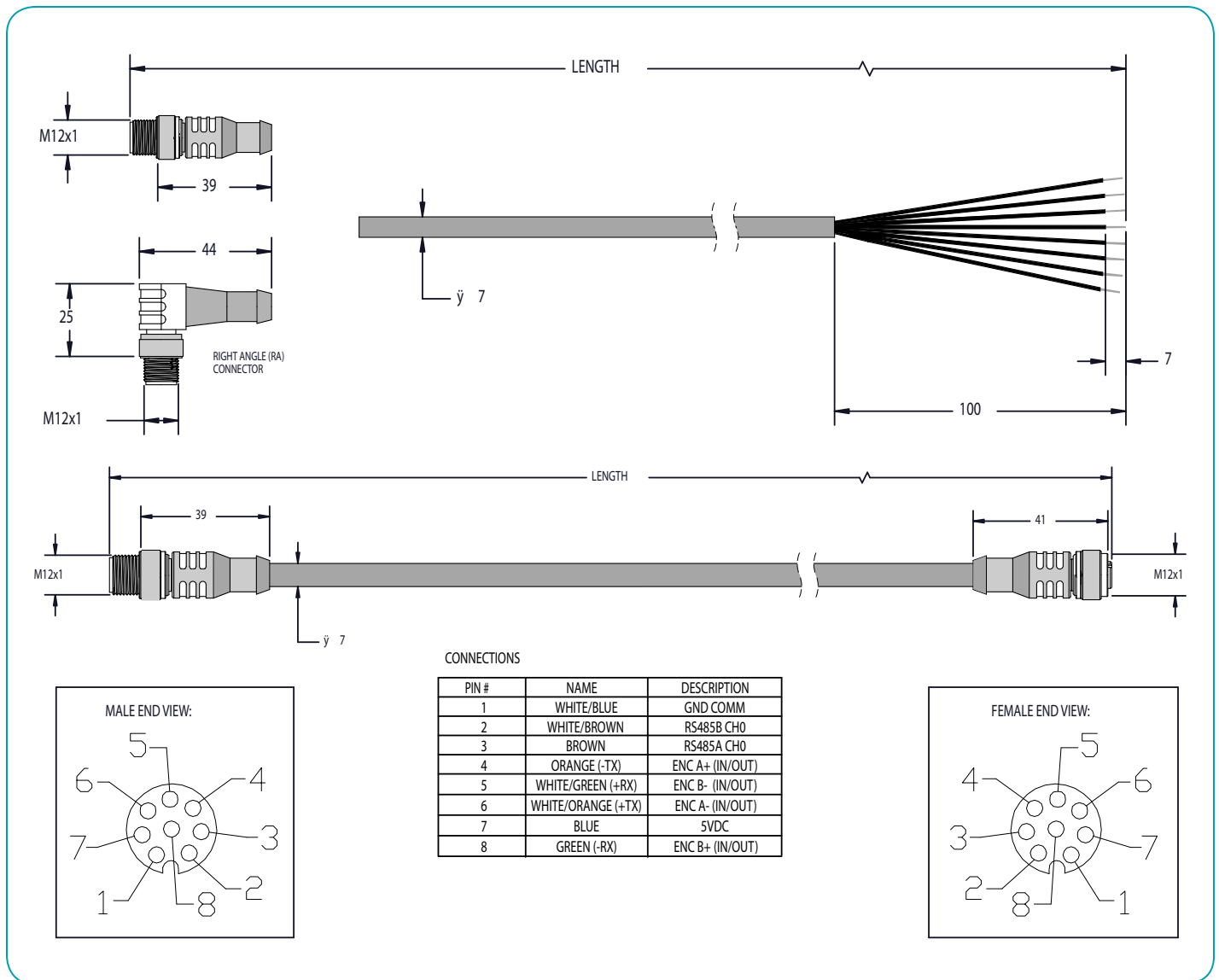

OVERVIEW
MOTOR SPECIFICATIONS
LINEAR SYSTEMS
CONNECTIVITY
PERIPHERALS
IP 65 MODELS & CONNECTIVITY
POWER SUPPLIES & SHUNTS
GEAR HEADS
SOFTWARE
APPENDIX

Communications and Encoder Bus Y Cable

This cable allows for daisy chain connection from one motor to the next. The communications port also contains pins for the bi-directional encoder bus. Data rates rated to >1MHz CBLIP-COM series cables are sealed M12 threaded connector brass pins w/ gold plating, maximum 2.0A. foil shield with black PVC jacket ~7.4mm dia.

Strait Connector

Part Number	Length
CBLIP-COM-Y1-0.5M	0.5 meters
CBLIP-COM-Y1-1M	1 meters
CBLIP-COM-Y1-3M	3 meters

Right Angle Connector

Part Number	Length
CBLIP-COM-Y1-0.5MRA	0.5 meters
CBLIP-COM-Y1-1MRA	1 meters
CBLIP-COM-Y1-3MRA	3 meters

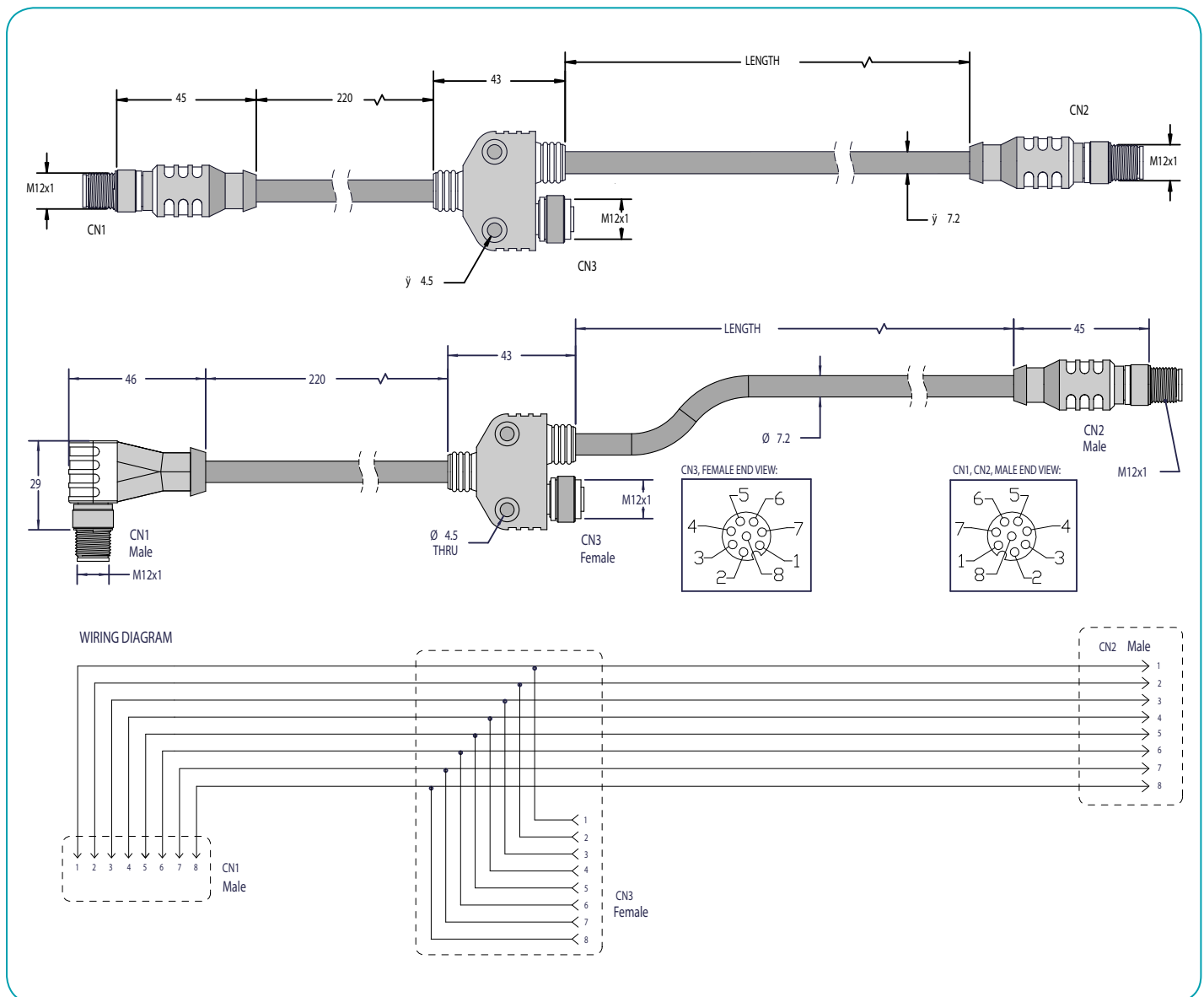

Travel Limit Input Cables

The Limit FL1 cables are standard unshielded cables intended for use with I/O signals only.

CBLIP series cables are sealed M12 threaded connector Brass pins w/Gold plating, Maximum 4.0A 250V Foil shield with Black PVC jacket ~7.4mm Dia.

Part Number	Description	Length
CBLIP-LIM-FL-1M	Flying Lead Strait Connector	1 meter
CBLIP-LIM-FL-3M	Flying Lead Strait Connector	3 meters
CBLIP-LIM-EXT-1M	Limit Bus Extension Cable	1 meter
CBLIP-LIM-EXT-2M	Limit Bus Extension Cable	2 meters
CBLIP-LIM-EXT-3M	Limit Bus Extension Cable	3 meters

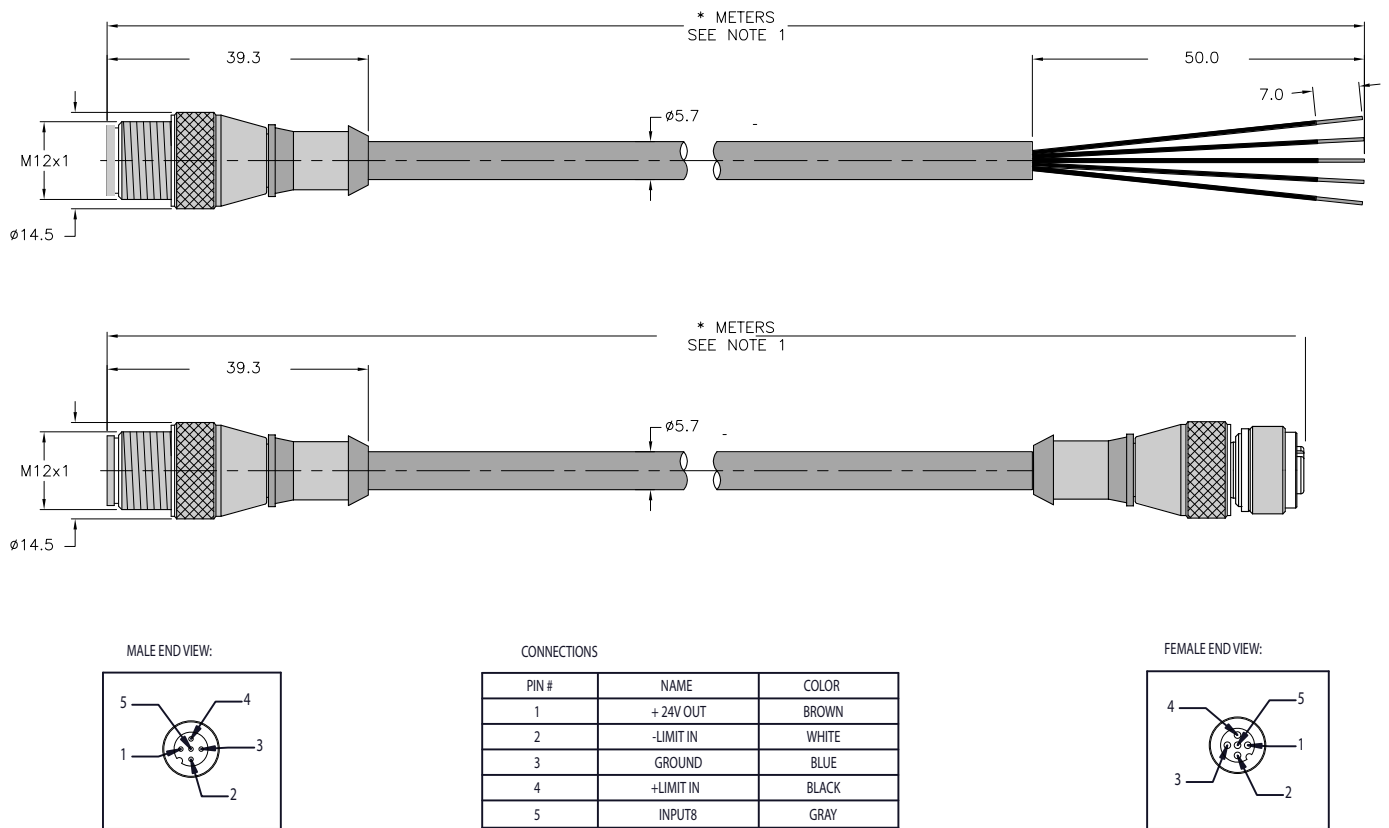

CBLIP-LIM-Y1-xM-xm (Animatics™ “Add-A-Motor™” Cable)

CBLIP-LIM-Y1 series cables are intended as a break out cable for the travel limit input connectors of the IP65 sealed SmartMotors. As seen below, this cable terminates to two PicoFast standard sensor connectors allowing direct field connection to various proximity sensors on the market.

Length options are based on connector 1 and 2 where the first length is for cable length to connector 1 and the second is for length to connector 2.

Part Number	Length
CBLIP-LIM-Y1-0.5M-1M	IP Limit Y Cable, 0.5 X 1.0 Meter
CBLIP-LIM-Y1-0.5M-2M	IP Limit Y Cable, 0.5 X 2.0 Meter
CBLIP-LIM-Y1-3M-3M	IP Limit Y Cable, 3.0 M X 3.0 Meter

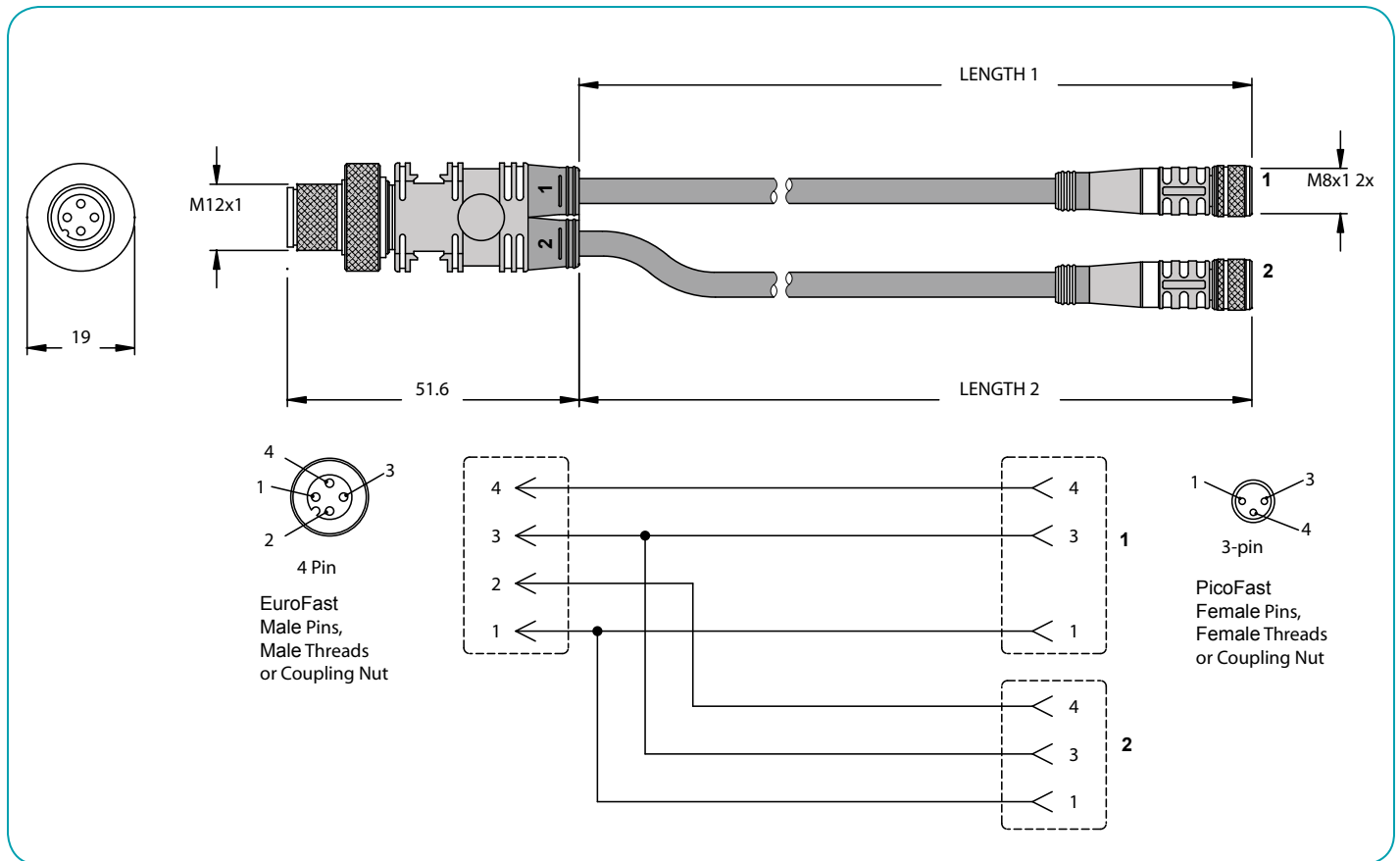

OVERVIEW
MOTOR SPECIFICATIONS
LINEAR SYSTEMS
CONNECTIVITY
PERIPHERALS
IP 65 MODELS & CONNECTIVITY
POWER SUPPLIES & SHUNTS
GEAR HEADS
SOFTWARE
APPENDIX

CAN Bus Flying Lead Cables, Straight

The CAN FL1 cables are standard CAN bus communications cables rated to >1MB data transmission rates. CBLIP series cables are sealed M12 threaded connector brass pins w / gold plating, maximum 4.0A. 250V foil shield with black PVC jacket ~7.4mm dia.

Part Number	Description	Length
CBLIP-CAN-FL-1M	Flying Lead Strait Connector	1 meter
CBLIP-CAN-FL-3M	Flying Lead Strait Connector	3 meters
CBLIP-CAN-EXT-1M	CAN Bus Extension Cable	1 meter
CBLIP-CAN-EXT-2M	CAN Bus Extension Cable	2 meters
CBLIP-CAN-EXT-3M	CAN Bus Extension Cable	3 meters

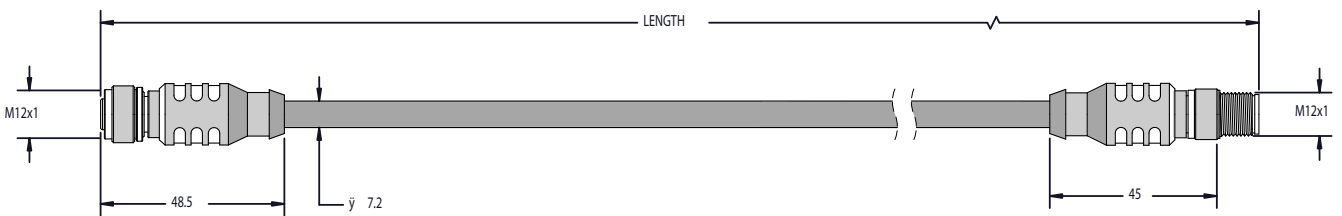
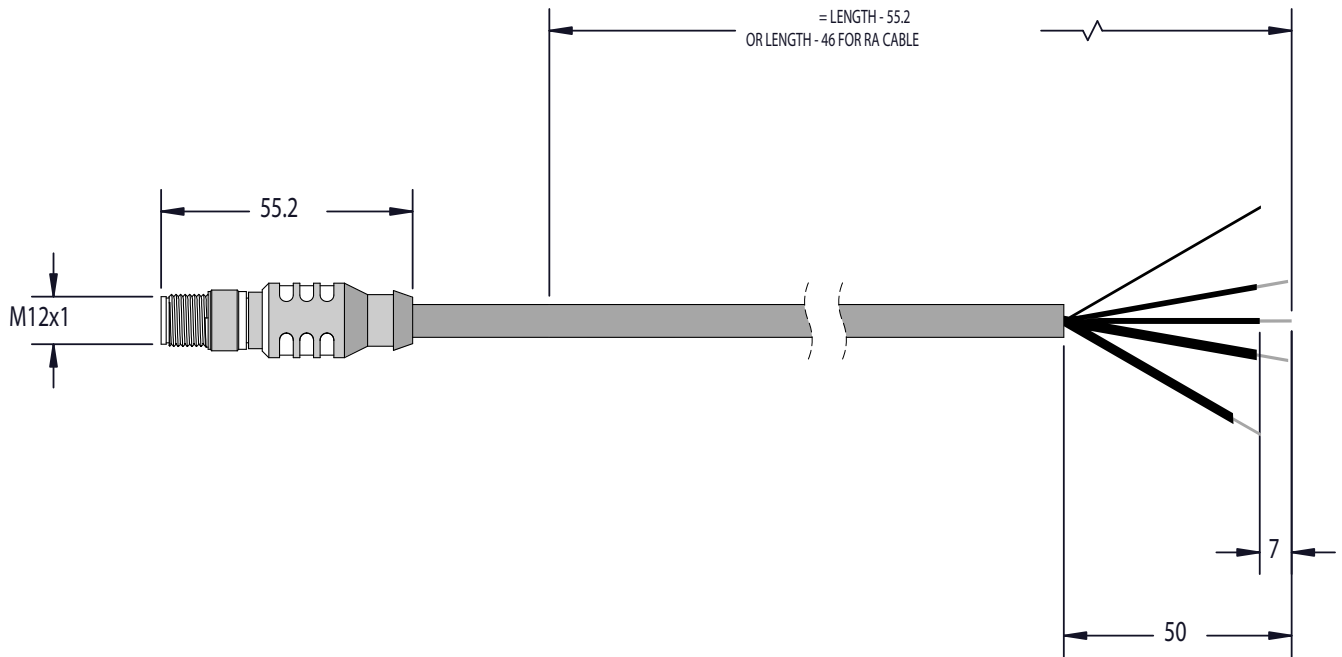

MALE END VIEW:

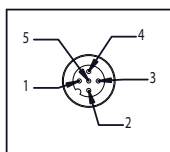

CONNECTIONS

PIN #	NAME	COLOR
1	SHIELD	BARE
2	+VOLTAGE	RED
3	-VOLTAGE	BLACK
4	CAN_H	WHITE
5	CAN_L	BLUE

FEMALE END VIEW:

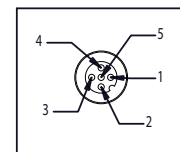

CAN Bus Y Cables, Straight Connector

The CAN Y1 series is meant for CAN Bus communications connectivity between two motors with the addition of a T-connector in line. Rated to >1MB data transmission rates.

This allows for cascading of multiple SmartMotor servos and the addition of a shunt resistor when required.

CBLIP series cables are sealed M12 threaded connector brass pins w / gold plating, maximum 4.0A. 250V foil shield with black PVC jacket ~7.4mm dia.

CANopen DeviceNet (5-Pin)

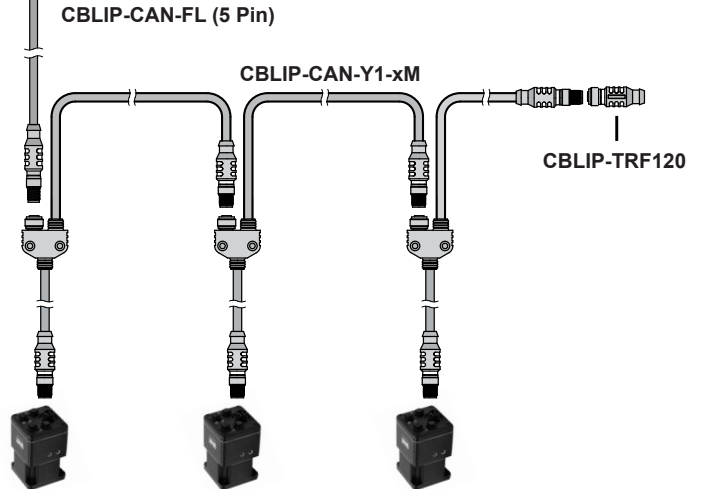

Strait Connector

Part Number	Length
CBLIP-CAN-Y1-0.5M	0.5 meters
CBLIP-CAN-Y1-1M	1 meters
CBLIP-CAN-Y1-3M	3 meters

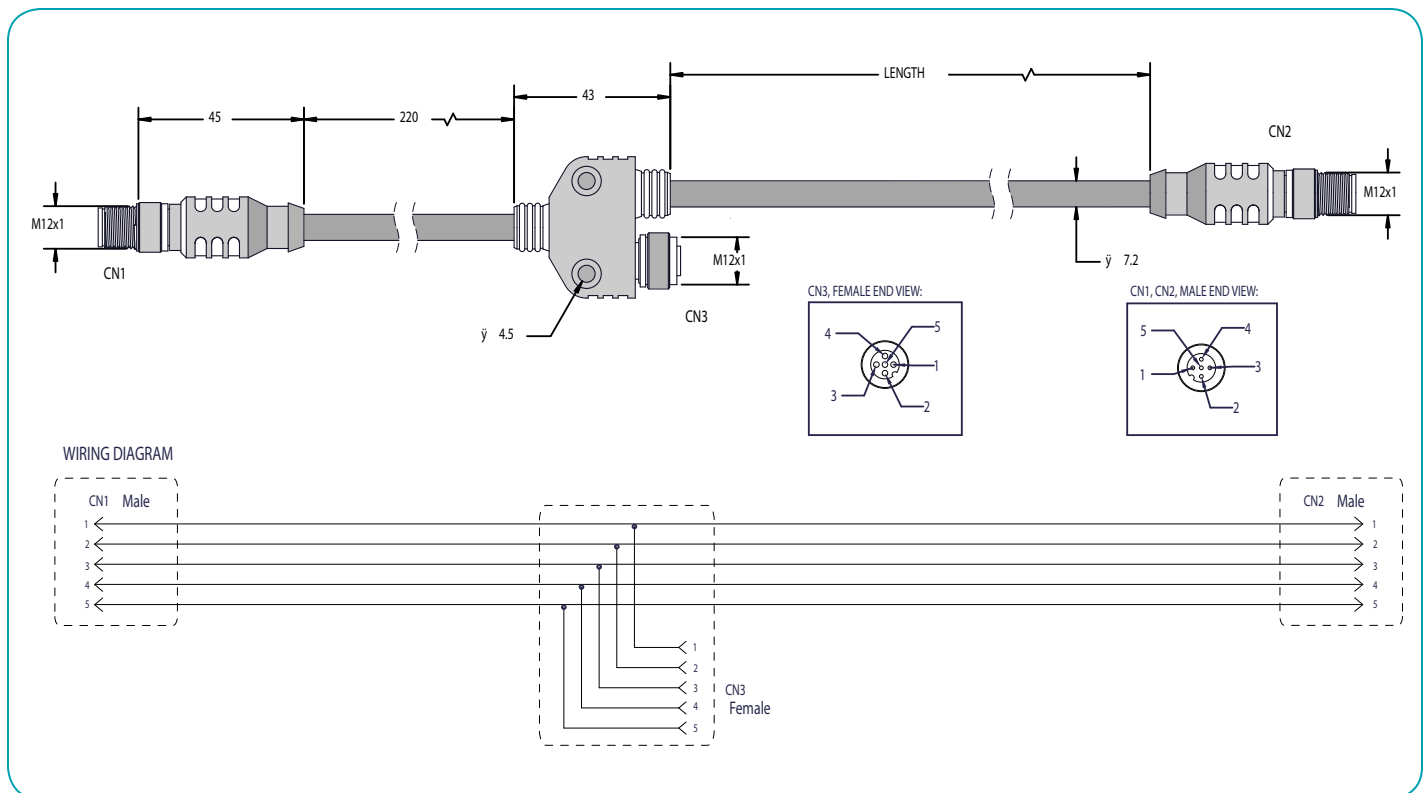

Note: At least one shunt resistor is required on ALL CAN bus networks. Please consult the factory for additional information.

I/O Cables (IP65 Models)

CBLIO-IO 24VDC TTL I/O Cable

The expanded I/O cables are for use with the -AD1 expanded I/O option on all Class 5 IP65 sealed SmartMotor servos. Each cable is a 12 conductor shielded cable. 2 conductors are for +24VDC I/O power. The other 10 are for 10 channels of I/O.

CBLIP series cables are sealed M12 threaded connector brass pins w / gold plating, maximum 4.0A. 250V foil shield with black PVC jacket ~7.4mm dia.

Part Number	Description	Length
CBLIP-IO-FL-1M	Flying Lead Strait Connector	1 meter
CBLIP-IO-FL-3M	Flying Lead Strait Connector	3 meters
CBLIP-IO-EXT-1M	I/O Extension Cable	1 meters
CBLIP-IO-EXT-2M	I/O Extension Cable	2 meters
CBLIP-IO-EXT-3M	I/O Extension Cable	3 meters

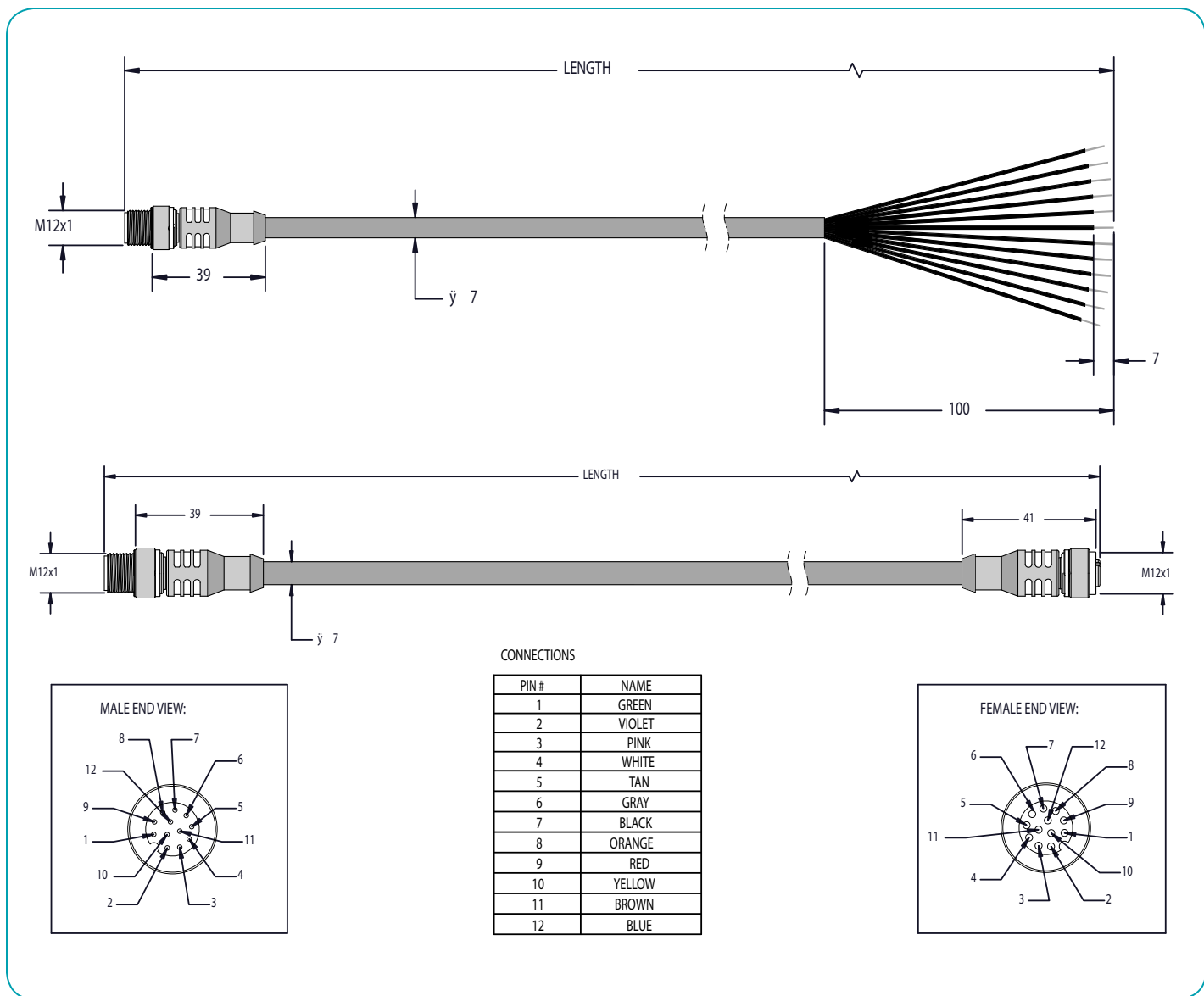

OVERVIEW
MOTOR SPECIFICATIONS
LINEAR SYSTEMS
CONNECTIVITY
PERIPHERALS
IP 65 MODELS & CONNECTIVITY
POWER SUPPLIES & SHUNTS
GEAR HEADS
SOFTWARE
APPENDIX

Notes



How to Choose Power Supplies

OVERVIEW
MOTOR SPECIFICATIONS
LINEAR SYSTEMS
CONNECTIVITY
PERIPHERALS
IP 65 MODELS & CONNECTIVITY
POWER SUPPLIES & SHUNTS
GEAR HEADS
SOFTWARE
APPENDIX

Which is better, Linear or Switcher Supplies?

Since servo motors are inductive they may run highly dynamic motion profiles. As a result, their current demand can vary widely. Surge currents from stand-still to maximum load may be extremely high, yet steady state current demand over time may be relatively mild. As a result, proper care should be taken when selecting power supplies.

Animatics offers two basic types of power supplies.

The chart to the right gives a brief comparison of the two types of supplies.

	Linear	Switcher
AC Input	Field selectable (120/240VAC)	Universal 90-240VAC
Power Factor Corrected	No	Yes
Relative Size	Big and bulky	Lightweight
Cooling	Ambient convection	Fan cooled
Surge Capacity	400%	5%
Voltage Regulation	15% Drop over range	0%, Fixed
Shunt Required ? ¹	Occasionally, but not typically	In most cases, highly recommended!

¹ See shunt section for more information!

As seen in the graph to the right, Linear (unregulated) supplies can handle large surge current loads. This is because Linear Supplies typically contain large output capacitors to handle those surges well.

Voltage regulation: Switchers are highly regulated supplies. They will maintain fixed voltage until they reach maximum load and then will “crowbar” to zero volts to protect the output stages. Linear supplies will slowly drop in output voltage while supplying more and more current.

This is the most fundamental difference between switchers and unregulated supplies.

Even though a switcher cannot handle the higher current surges, if it can output as much current as you would expect for a given servo application, then they will actually help the servo accelerate much faster because system voltage will be maintained at maximum level.

However, if your servo application requires surge currents in excess of 50 Amps or more, the switchers may not be cost effective. Getting 50 amps from an Animatics 20 Amp supply is easy. Getting 50 Amps from Animatics switchers would require placing multiple units in parallel, so it may not be cost effective to do so.

Voltage Drop Comparison

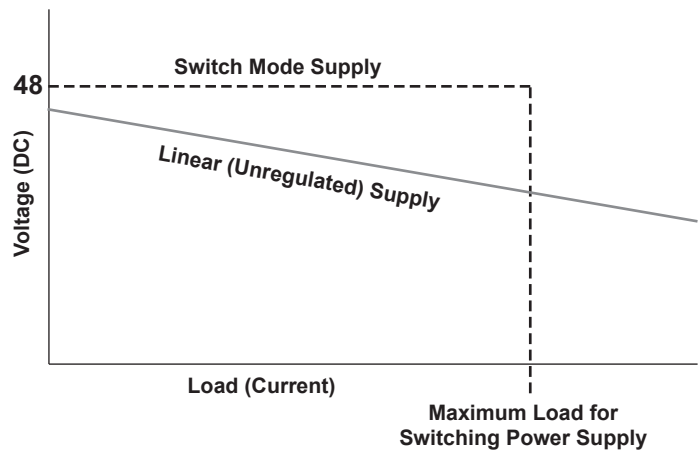

Warning: Improper Power Supply Sizing may result in Motor Position Error Faults, Motor Resets, and Machine Faults

Open Frame Linear Unregulated DC Power Supplies

Power Supplies:

- Linear Unregulated
- AC Input, DC output
- Screw Terminal Access
- Toroid Transformer for lower EMI

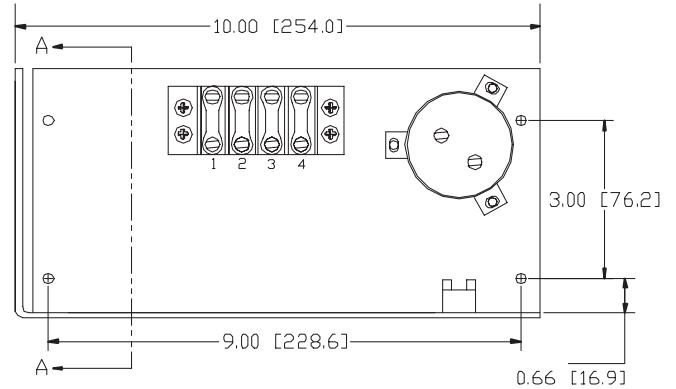
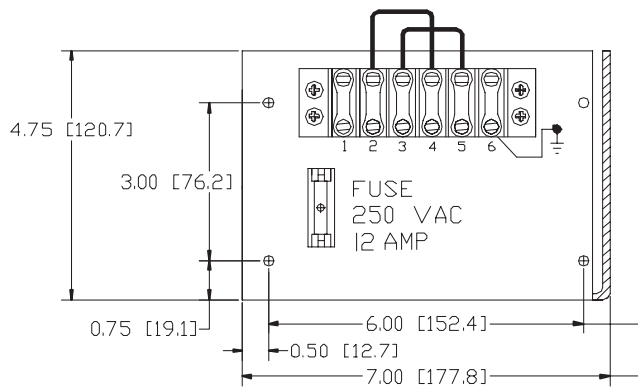

All sizes are given in inches, sizes in brackets are in mm

Part Number	Input Voltage and Frequency	No Load Output Voltage	Full Load Output		Nominal Wattage	Shunt	Weight(Nom.)
			Voltage	Current			
PS42V20AF110	120VAC 50/60Hz	44VDC	35VDC	20 Amps	680 W		16.5 lbs (7.5kg)
PS42V20AF220	240VAC 50/60Hz	44VDC	35VDC	20 Amps	680 W		16.5 lbs (7.5kg)
PS42V20AF110-S1	120VAC 50/60Hz	44VDC	35VDC	20 Amps	680 W	100 W	17 lbs (7.7kg)
PS42V20AF220-S1	240VAC 50/60Hz	44VDC	35VDC	20 Amps	680 W	100 W	17 lbs (7.7kg)
PS42V20AF110-S2	120VAC 50/60Hz	44VDC	35VDC	20 Amps	680 W	200 W	17 lbs (7.7kg)
PS42V20AF220-S2	240VAC 50/60Hz	44VDC	35VDC	20 Amps	680 W	200 W	17 lbs (7.7kg)

Warning: Improper Power Supply Sizing may result in Motor Position Error Faults, Motor Resets, and Machine Faults



OVERVIEW
MOTOR SPECIFICATIONS
LINEAR SYSTEMS
CONNECTIVITY
PERIPHERALS
IP 65 MODELS & CONNECTIVITY
POWER SUPPLIES & SHUNTS
GEAR HEADS
SOFTWARE
APPENDIX

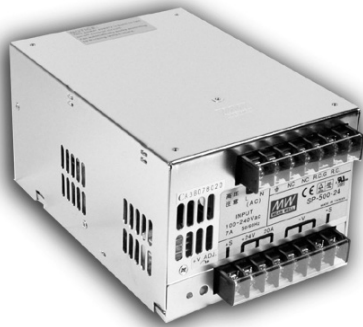

PFC500W-48 Features

- Universal AC input / Full range
- Built-in active PFC function, PF>0.95
- Protections: Short circuit / Overload/ Over voltage / Over temperature
- Forced air cooling by built-in DC fan
- Built-in cooling Fan ON-OFF control
- Built-in remote ON-OFF control
- Built-in remote sense function
- Fixed switching frequency at 110KHz
- 2 years warranty

OUTPUT	DC VOLTAGE	48V
	RATED CURRENT	10A
	CURRENT RANGE	0 ~ 10A
	RATED POWER	480W
	RIPPLE & NOISE (max) Note.2	3~mVp-p
	VOLTAGE ADJ. RANGE	41 ~ 56V
	VOLTAGE TOLERANCE Note.3	± 1.0%
	LINE REGULATION	± 0.5%
	LOAD REGULATION	± 0.5%
	SETUP, RISE TIME	1500 ms, 50 ms at full load
HOLD UP TIME (Typ.)	24 ms at full load	
INPUT	VOLTAGE RANGE Note.5	88 ~ 264VAC 124 ~ 370VDC
	FREQUENCY RANGE	47 ~ 63Hz
	POWER FACTOR (Typ.)	PF>0.95/230VAC PF>0.95/115VAC at full load
	EFFICIENCY(Typ.)	87%
	AC CURRENT (Typ.)	7A/115VAC 3.5A/230VAC
	INRUSH CURRENT (Typ.)	18A/115VAC 36A/230VAC
PROTECTION	OVER VOLTAGE	57.6 ~ 67.2V
FUNCTION	REMOTE CONTROL	RC+/RC-: Short = power on ; Open = power off
	WORKING TEMP.	-10 ~ +50°C (Refer to output load derating curve)
	WORKING HUMIDITY	20 ~ 90% RH non-condensing
ENVIRONMENT	STORAGE TEMP., HUMIDITY	-20 ~ +85°C, 10 ~ 95% RH
SAFETY & EMC (Note 4)	SAFETY STANDARDS	UL60950-1, TUV EN60950-1 approved
	WITHSTAND VOLTAGE	I/P-O/P:3KVAC I/P-FG:1.5KVAC O/P-FG:0.5KVAC
	ISOLATION RESISTANCE	I/P-O/P, I/P-FG, O/P-FG:100M Ohms/500VDC
	EMI CONDUCTION & RADIATION	Compliance to EN55022 (CISPR22) Class B
	HARMONIC CURRENT	Compliance to EN61000-3-2,-3
	EMS IMMUNITY	Compliance to EN61000-4-2,3,4,5,6,8,11; ENV50204, light industry level, criteria A
OTHERS	MTBF	133.4K hrs min. MIL-HDBK-217F (25°C)
	DIMENSION	170*120*93mm (L*W*H)
NOTE	<ol style="list-style-type: none"> 1. All parameters NOT specially mentioned are measured at 230VAC input, rated load and 25°C of ambient temperature. 2. Ripple & noise are measured at 20MHz of bandwidth by using a 12" twisted pair-wire terminated with a 0.1uf & 47uf parallel capacitor. 3. Tolerance: includes set up tolerance, line regulation and load regulation. 4. The power supply is considered a component which will be installed into a final equipment. The final equipment must be re-confirmed that it still meets EMC directives. 5. Derating may be needed under low input voltages. Please check the derating curve for more details. 	

Warning: Improper Power Supply Sizing may result it Motor Position Error Faults, Motor Resets, and Machine Faults

Mechanical Specifications

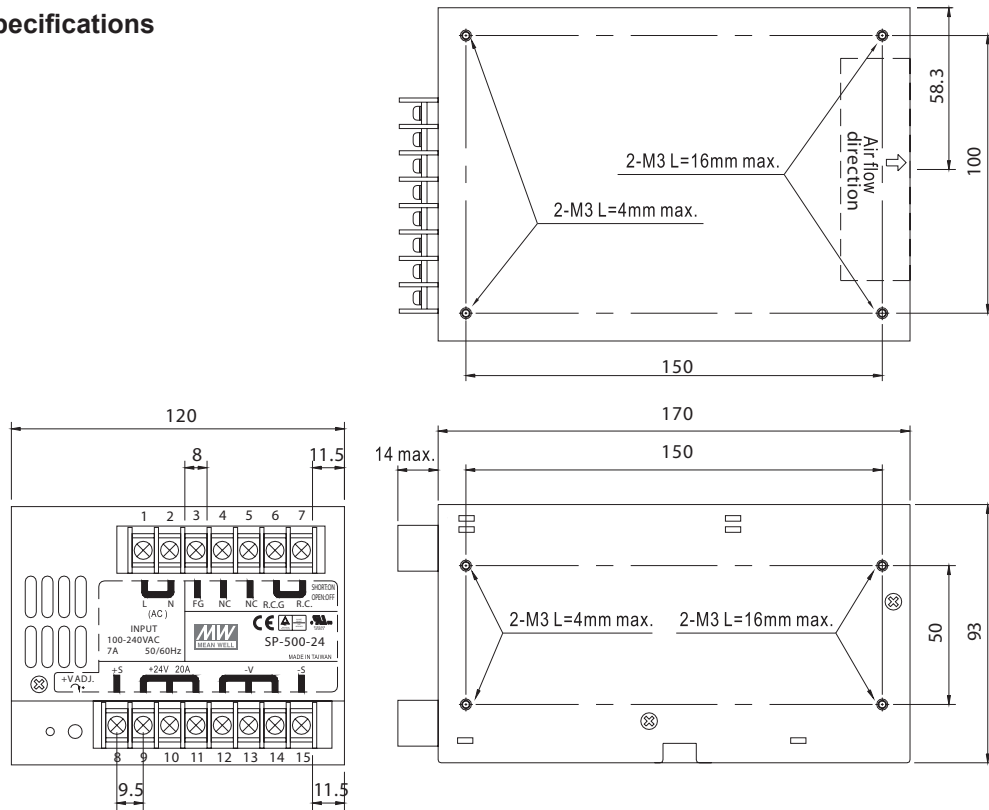

Terminal Pin No. Assignment

Pin No.	Assignment	Pin No.	Assignment
1	AC/L	7	R.C.
2	AC/N	8	+S
3	FG \perp	9~11	DC OUTPUT +V
4,5	NC	12~14	DC OUTPUT -V
6	R.C.G	15	-S

Output Derating vs. Input Voltage

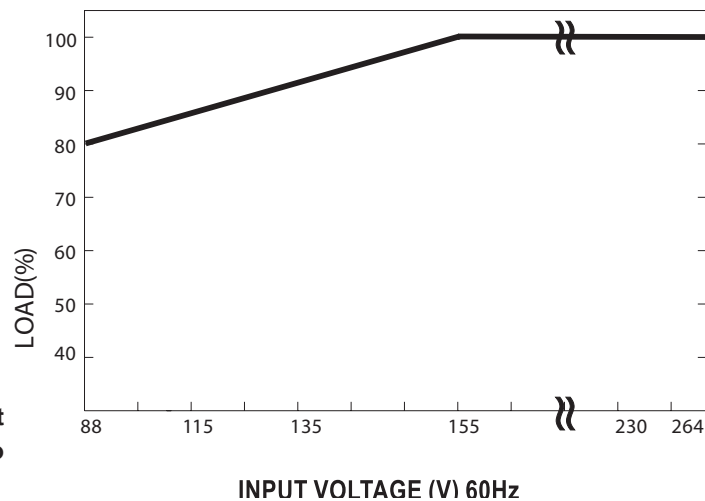

WARNING

The switcher supplies have an adjustable output trim pot. The output voltage **MUST BE** adjusted to $\leq 48\text{VDC}$.

Warning: Improper Power Supply Sizing may result in Motor Position Error Faults, Motor Resets, and Machine Faults



PFC1500W-48 Features:

- Universal AC input / Full range
- AC input active surge current limiting
- Built-in active PFC function, PF>0.95
- Protections: Short circuit / Overload / Over voltage / Over temperature
- Forced air cooling by built-in DC fan
- Built-in cooling fan ON-OFF control
- Built-in remote ON-OFF control
- Built-in remote sense function
- 2 year warranty

NOTE: Multiple units may be paralleled for additional power

OUTPUT	DC VOLTAGE	48V
	RATED CURRENT	32A
	CURRENT RANGE	0 ~ 32A
	RATED POWER	1536W
	RIPPLE & NOISE (max) Note.2	200mVp-p
	VOLTAGE ADJ. RANGE	43 ~ 56V
	VOLTAGE TOLERANCE Note.3	± 1.0%
	LINE REGULATION	± 0.5%
	LOAD REGULATION	± 0.5%
	SETUP, RISE TIME	1500ms, 100ms at full load
HOLD UP TIME (Typ.)	16 ms at full load	
INPUT	VOLTAGE RANGE Note.5	88 ~ 264VAC 124 ~ 370VDC
	FREQUENCY RANGE	47 ~ 63Hz
	POWER FACTOR (Typ.)	0.95/230VAC 0.98/115VAC at full load
	EFFICIENCY(Typ.)	91%
	AC CURRENT (Typ.)	17A/115VAC 8A/230VAC
	INRUSH CURRENT (Typ.)	30A/115VAC 60A/230VAC
	LEAKAGE CURRENT	<2.0mA/240VAC
PROTECTION	OVERLOAD Note.5	105 ~ 135% rated output power Protection type: Constant current limiting unit will shut down o/p voltage after 5 sec. Re-power to recover
	OVER VOLTAGE	57.6 ~ 67.2V Protection type: Shut down o/p voltage, recover automatically after temperature goes down
	OVER TEMPERATURE	95°C ± 5°C detect on heatsink of power transistor Protection type: Shut down o/p voltage, recovers automatically after temperature goes down
FUNCTION	AUXILIARY POWER (AUX)	12V@0.1A (Only for Remote ON/OFF control)
	REMOTE CONTROL	RC+/RC-: Short = power on ; Open = power off
	WORKING TEMP.	-10 ~ +50°C (Refer to output load derating curve)
	WORKING HUMIDITY	20 ~ 90% RH non-condensing
ENVIRON- MENT	WORKING TEMP.	-20 ~ +70°C (Refer to output load derating curve)
	WORKING HUMIDITY	20 ~ 90% RH non-condensing
	STORAGE TEMP., HUMIDITY	-40 ~ +85°C, 10 ~ 95% RH
	TEMP. COEFFICIENT	± 0.5%/°C (0 ~ 50 °C)
	VIBRATION	10 ~ 500Hz, 2G 10min./1cycle, 60min. each along X,Y,Z axis
SAFETY & EMC (Note 4)	SAFETY STANDARDS	UL60950-1, TUV EN60950-1 approved
	WITHSTAND VOLTAGE	I/P-O/P:3KVAC I/P-FG:1.5KVAC O/P-FG:0.5KVAC
	ISOLATION RESISTANCE	I/P-O/P, I/P-FG, O/P-FG:100M Ohms/500VDC
	EMI CONDUCTION & RADIATION	Compliance to EN55022 (CISPR22)
	HARMONIC CURRENT	Compliance to EN61000-3-2,-3
	EMS IMMUNITY	Compliance to EN61000-4-2,3,4,5,6,8,11; ENV50204, light industry level, criteria A
OTHERS	MTBF	62.6K hrs min. MIL-HDBK-217F (25°C)
	DIMENSION	278*127*83.5mm (L*W*H)
	PACKING	2.6Kg: 6PCS/16.6Kg/1.54CUFT
NOTE	<ol style="list-style-type: none"> 1. All parameters NOT specially mentioned are measured at 230VAC input, rated load and 25°C of ambient temperature. 2. Ripple & noise are measured at 20MHz of bandwidth by using a 12" twisted pair-wire terminated with a 0.1uf & 47uf parallel capacitor. 3. Tolerance: includes set up tolerance, line regulation and load regulation. 4. The power supply is considered a component which will be installed into a final equipment. The final equipment must be re-confirmed that it still meets EMC directives. 5. Derating may be needed under low input voltages. Please check the derating curve for more details. 	

Warning: Improper Power Supply Sizing may result in Motor Position Error Faults, Motor Resets, and Machine Faults

Mechanical Specifications

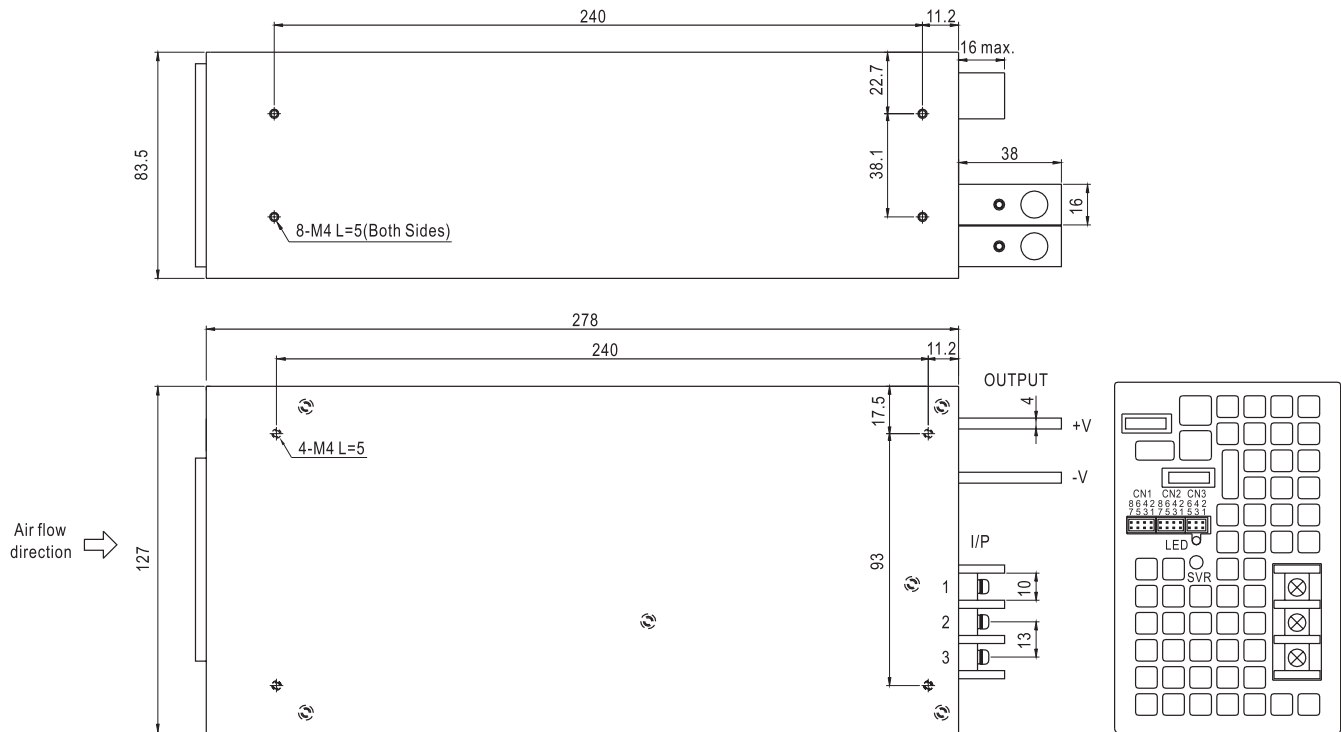

AC Input Terminal Pin No. Assignment

Pin No.	Assignment
1	FG \perp
2	AC/N
3	AC/L

Control Pin No. Assignment(CN1, CN2) : HRS DF11-8DP-2DS or equivalent

Pin No.	Assignment	Pin No.	Assignment	Mating Housing	Terminal
1	RCG	4	TRIM	HRS DF11-8DS or equivalent	HRS DF11-**SC or equivalent
2	RC2	6	LS(Current Share)		
3,5,7	-S	8	+S		

RCG: Remote ON/OFF Ground

RC2: Remote ON/OFF

-S : -Remote Sensing

TRIM: Adjustment of Output Voltage

LS: Load Share

+S: +Remote Sensing

Control Pin No. Assignment(CN3) : HRS DF11-6DP-2DS or equivalent

Pin No.	Assignment	Pin No.	Assignment	Mating Housing	Terminal
1	P OK GND	4	AUXG	HRS DF11-6DS or equivalent	HRS DF11-**SC or equivalent
2	P OK	5	RC1		
3	RCG	6	AUX		

P OK GND: Power OK Ground

P OK: Power OK Signal

RCG: Remote ON/OFF Ground

AUXG: Auxiliary Ground

RC1: Remote ON/OFF

AUX: Auxiliary Output

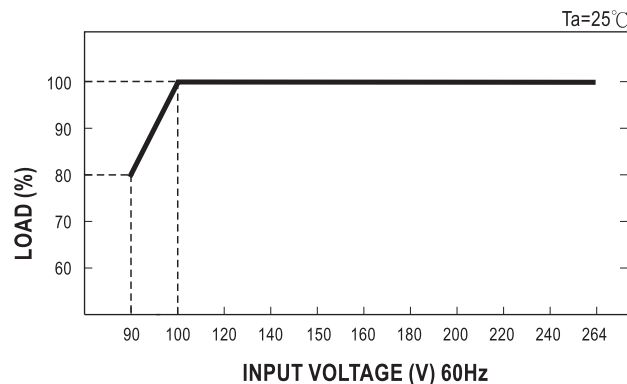

⚠ WARNING

The switcher supplies have an adjustable output trim pot. The output voltage **MUST BE** adjusted to $\leq 48\text{VDC}$.

Enclosed DC Power Supplies

- Enclosed linear unregulated power supplies
- PC-type AC power cord
- 4 pin AMP connector on output
- Internally fused on both primary and secondary side
- Toroid transformer for minimal voltage drop and minimal EMI



Includes AC Power Cord and KITDC1 connector kit

Part Number	Input Voltage	Hz AC	No Load Voltage	Full Load		Nominal Wattage	Weight (Nom.)
				Voltage	Current		
PS24V8AG-110	110VAC	60	25 VDC	19 VDC	8 Amps	152 W	6.5 lbs (3 kg)
PS42V6AG-110	110VAC	60	46 VDC	38.7 VDC	6.5 Amps	251 W	7 lbs (3.2 kg)
PS42V6A-220CE	220 VAC	50-60	46 VDC	38.7 VDC	6.5 Amps	251 W	7 lbs (3.2 kg)

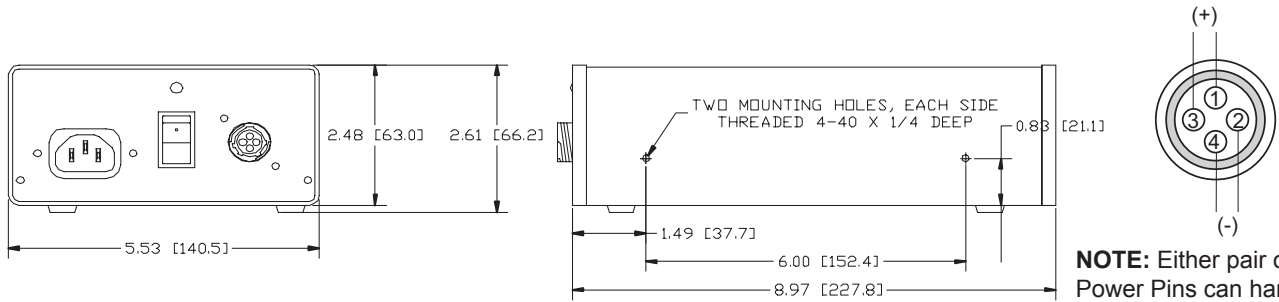

* All sizes are given in inches, sizes in brackets are in mm

NOTE: Either pair of Power Pins can handle full load rating

PWR116V

Enclosed Laptop Type Power Supply

This Power Supply connects directly to:

- CBLSM1-DEMO
- SmartBox™
- SmartBox BCD™

It is ideal for desktop testing of the SmartMotor™ and will easily run an unloaded SmartMotor for programming and evaluation testing.

Input: 100-240VAC 50/60Hz
 Output: 24VDC, 2.5Amps, 60 Watts
 Connector Type: 2.1x5mm coax DC Power Connector
 Cable Length: ~1meter
 RoHS/CE Certified



CBLAC1

AC Power Cable for PWR116V Power Supply above.

Standard 3 prong US AC plug

~1 Meter length



Warning: Improper Power Supply Sizing may result in Motor Position Error Faults, Motor Resets, and Machine Faults

Introduction to Shunts

Animatics offers several shunt options for use with DC input servo motors.

Shunts are needed to protect the servo controller and drive stages from over voltage.

Over voltage sources originate from the following:

- Back EMF due to back driving the motors
- Sudden or hard decelerations
- Hard stop crashes (immediate deceleration to zero speed)
- Vertical load drops

The shunts actually add an additional load to the DC bus automatically when voltage exceeds the trigger level by connecting large load resistors across the bus. Trigger voltage is typically 49.5VDC. As a result, the shunts will work with any of the supplies we offer.

WARNING

The switcher supplies have an adjustable output trim pot. If used with our shunts, the output voltage MUST BE adjusted to $\leq 48\text{VDC}$ to insure the shunts do not stay gated on.

The Real story about Back EMF:

Generally speaking, Back EMF is the voltage generated in a motor when it spins. This voltage is typically proportional to speed. However, this is a general rule. The truth is that the Back EMF voltage is proportional to the rate of change of magnetic flux in the windings of the stator. As a result, constant speeds produce constant and predictable voltages. However, sudden changes due to decelerations or hard stop crashes cause an immediate change in magnetic flux or even a total instantaneous collapse. As a result, voltages can go 5 to 10 times higher than spinning the motor at its maximum speed.

For this reason alone it is highly recommended to use a shunt in all vertical load applications or any case where the motors could be stopped quickly or back driven suddenly.

We offer both open frame and enclosed shunts in 100Watt and 200Watt capacities. The shunts are all automatic and get their power from the DC bus they are attached to. They simply need to be placed in parallel with the DC bus.

WARNING

1. Shunts cannot be placed in parallel with each other to increase capacity. The shunt with the slightly lower trigger voltage will trigger first while the other shunt never triggers at all. Please consult factory for information on how to deal with larger shunt requirements.

2. Shunts should always be placed between the motor input and any disconnect or e-stop relay to insure protection of the motor when power is not applied or e-stop relay contacts are open.



Open Frame Shunts

SHUNT42V100WOF and SHUNT42V200WOF

- Can be used with Power supplies that have an output of 48VDC or less
- Automatic Gate-On when Voltage Exceeds 49.5VDC
- Easy direct parallel connection to power supply



SHUNT42V100W-OF



SHUNT42V200W-OF

Part Number	TRIGGER VOLTAGE	DROP OUT VOLTAGE	CURRENT DRAW WHEN GATED ON	WATTS	EFFECTIVE BUS LOAD
SHUNT42V100WOF	49.5VDC RISING	48.5VDC FALLING	4 AMPS	100W	12.5 OHMS
SHUNT42V200WOF	49.5VDC RISING	48.5VDC FALLING	8 AMPS	200W	6.25 OHMS

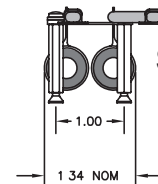
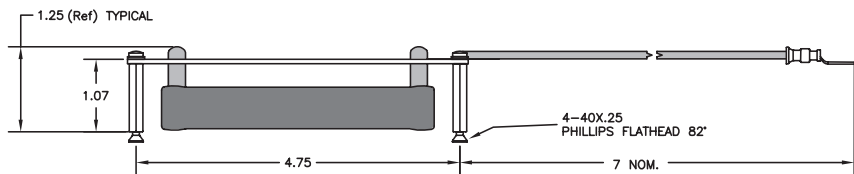
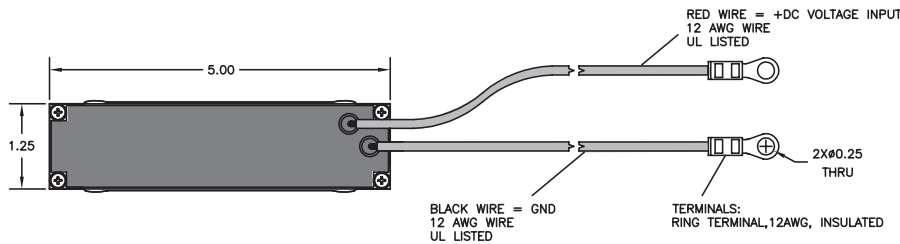

SHUNT42V100WOF

BETWEEN 24V/48V AND PWR GND.
 6 CONNECTIONS: RED WIRE +DC VOLTAGE INPUT
 BLACK WIRE -DC VOLTAGE INPUT
 7 USE PROPER ELECTRICAL SAFETY PRECAUTIONS.
 8 ALL DIMENSIONS ARE NOMINAL, UNLESS OTHERWISE SPECIFIED

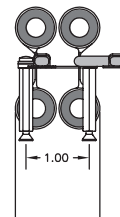
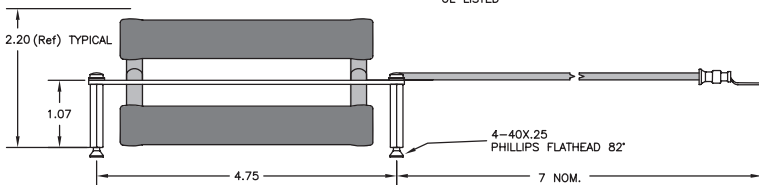
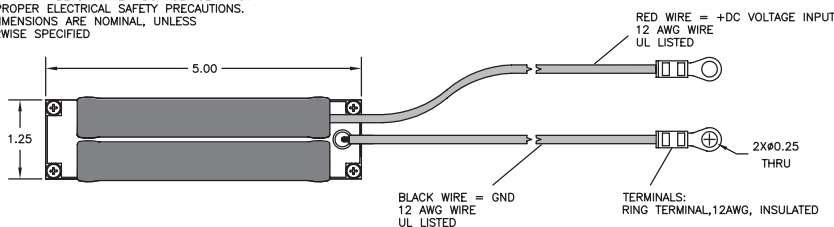

SHUNT42V200WOF

Note: Any time an E-Stop switch is placed on the DC power line to the motor, a Shunt **MUST BE** installed between the E-Stop switch and the motor connector to ensure protection against over voltage!



Warning ! If the shunt is connected to an adjustable power supply, the output voltage **MUST BE** set at or below 48VDC. If the output voltage is sustained above the trip point of the shunt, over heating and damage may result.

Enclosed Shunts

- Enclosed Shunt
- Matching 4 pin AMP connector to enclosed power supply.
- Automatically gate on at $\geq 49.5\text{VDC}$
- Powered from DC bus
- May be connected in parallel with any supply $\leq 48\text{VDC}$.



Part Number	TRIGGER VOLT-AGE	DROP OUT VOLT-AGE	CURRENT DRAW WHEN GATED ON	WATTS	EFFECTIVE BUS LOAD
SHUNT42V100W	49.5VDC RISING	48.5VDC FALLING	4 AMPS	100W	12.5 OHMS
SHUNT42V200W	49.5VDC RISING	48.5VDC FALLING	8 AMPS	200W	6.25 OHMS

Includes connector kits

Use with cable CBLDC1 below

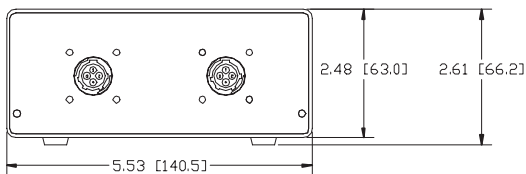

* All sizes are given in inches, sizes in brackets are in mm

Note: Any time an E-Stop switch is placed on the DC power line to the motor, a Shunt **MUST BE** installed between the E-Stop switch and the motor connector to ensure protection against over voltage!

CBLDC1



Power Supply Cables

Part Number	Connection	Cable Type	Connector Type(s)	Length(s)
CBLAC1	AC Line Cord for power supply	Power	N/A	6 ft (1.8m)
CBLDC1	DC Cable for Enclosed Shunt	DC	4-Pin AMP	1.5ft (0.45M)
CBLSMYPWR-T	Multiple SM - power supply	Y	4 Pin AMP	2 ft (0.61m)

Moment Of Inertia:

A basic understanding of Moment of Inertia serves well in ensuring proper motor sizing. It is one thing to look at static points on torque curves, but it is altogether different when considering the dynamic aspects of loads being accelerated at high rates.

The Inertial mass of an object is a measure of its resistance to a change in its velocity.

The Moment of Inertia of an object is at a point of reference of rotation, which is at the pivot point or axis of rotation.

The Moment of Inertia can therefore be thought of as a measure of the resistance to any change in rotational speed.

For linear systems, the rate of change of speed (acceleration) is proportional to the force applied. Double the mass and the force needs to be doubled for the same acceleration. Similarly for rotational systems, the angular acceleration of the load is proportional to the torque applied. Double the Moment of Inertia and the torque needs to be doubled for the same angular acceleration. Moment of Inertia is therefore a measure of a load's resistance to angular speed change; of how much effort (torque) is required to cause acceleration or deceleration.

Matching Motor To Load:

A common rule of thumb for SmartMotor™ sizing is that the load should have no more than 10 times the Moment of Inertia of the motor rotor that is driving it. This gives a good starting point and

typically allows for safe sizing over a wide range of applications.

Since a rotating load wants to maintain the same velocity, then when a motor attempts to accelerated or decelerate the load, it must overcome the Moment of Inertia of that load by applying enough torque to accelerate it or decelerate it.

It takes more torque to change speed than it does to maintain a given speed.

In the same manner, for the motor to slow down a load, the load's Moment of Inertia will keep the motor going the same speed and will, in effect, back-drive the motor turning it into a generator.

In extreme cases, this can result in over-voltage damage to the Drive stage.

How to Improve Moment of Inertia Ratio Between Motor and Load :

Adding gear reduction to a motor gives it more leverage to prevent back driving and also gives it a better advantage in accelerating a load up to speed.

For any given change in gear reduction, you get a proportional change in speed and static torque but you get a squared change in acceleration and dynamic rate of change of torque. The result is that by adding gear ratio you gain a squared decrease in the ratio of Moment of Inertia between motor and load.

Therefore the motor has a greater advantage in both accelerating and decelerating the load. It adds protection against damage to the system as a whole.

Lower System Cost

To give an idea of how much effect you get from additional gear reduction, take a look at the example below. This is an actual photo of the before-and-after drive system of a given application. The larger motor with low gear reduction and larger pulley was replaced by the smaller Animatics SmartMotor™ with much higher gear reduction and smaller pulley. The result was a smoother operating machine with higher resolution and better acceleration, increasing throughput and improving quality.

Optimize gear reduction to improve load dynamics and motor efficiency & reduce system cost

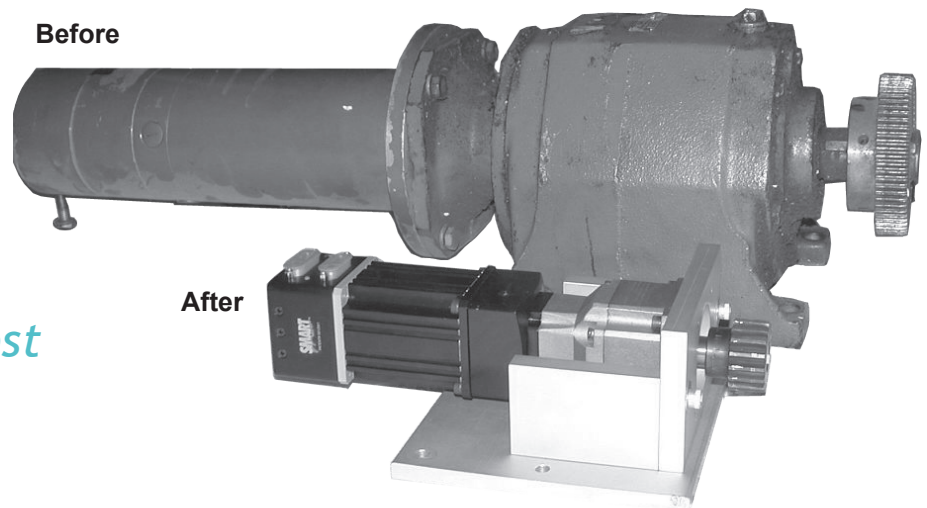

Introduction to Gearheads

All units are precision ground planetary gear sets capable of sustained servo input speed. They can be ordered by themselves, or pre-mounted to the SmartMotor™ prior to shipment.

Each gearhead has a non-captive input pinion gear. This means the pinion is mounted onto the motor shaft and the gearhead is then mounted onto the motor flange.

Torque throughput on in-line (straight) gearheads are limited by input pinion diameters.

Typically the 7:1 ratio single-stage and 28:2 ratio two-stage gearheads have the higher torque ratings.

10:1 and 100:1 gearhead input pinions are very small and great care should be taken not to exceed maximum torque ratings for those gear ratios.

All right angle gearhead torque levels are limited by the right angle beveled gear sets. This is why all gear ratios show the same torque limits within that series.

All gearheads are limited to a maximum of 5000 RPM input pinion speed. This limit is due to differential speed across the input pinion bearings and lubrication flow. Exceeding 5000 RPM for any sustained amount of period will GREATLY decrease the life of the gearhead and will not be covered by warranty. However, for typical servo applications, there is no issue with reaching 5000RPM on each machine cycle peak speeds.

Please consult the factory for axial and radial load specifications. Load ratings are speed dependant and are charted across curves.

All specifications are subject to change without notice. Please consult the factory or website for latest data and CAD drawings.

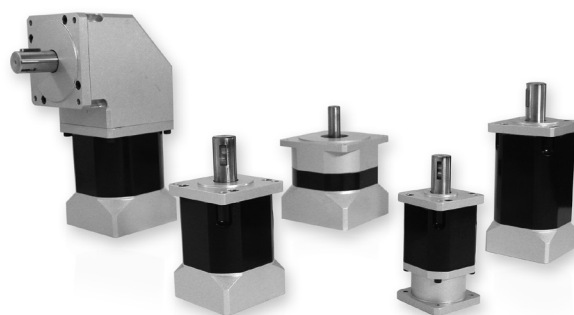

Gearhead Series	Backlash (arc-minutes)	
	Single Stage	Two Stage
High Performance (S)	3	7
OEM Series (SP)	6	10
Right Angle (RAP)	7	11

Note: These are the low backlash values.

Animatics provides three series of gearheads. The above chart is a quick reference to backlash specs.

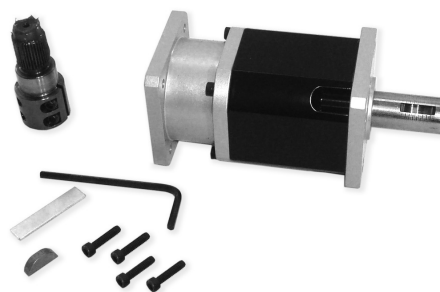

Each gearhead is shipped with appropriate mounting hardware, fasteners, Allen key and pinion gap gauge.

2 Stage Gearheads Shown

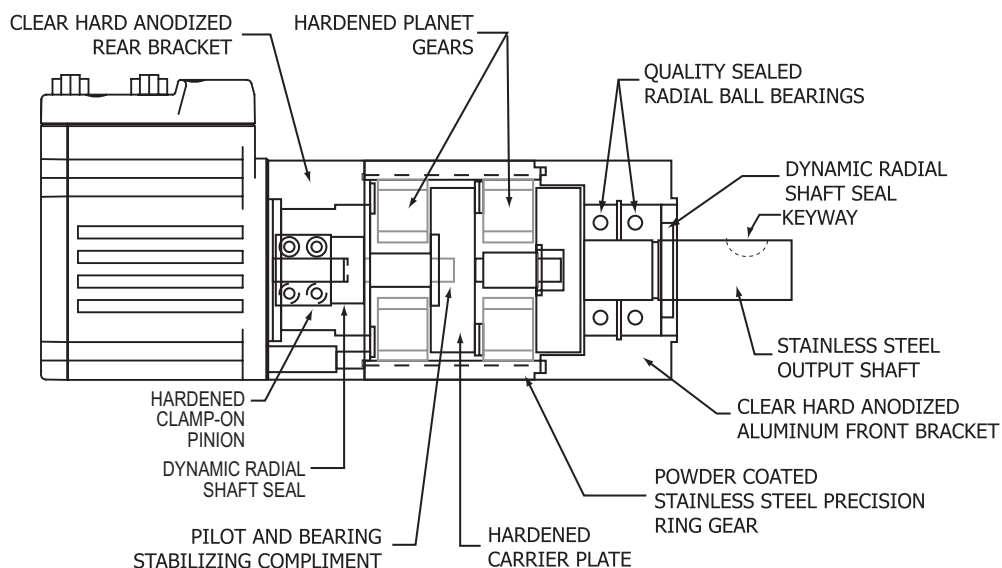

OVERVIEW
MOTOR SPECIFICATIONS
LINEAR SYSTEMS
CONNECTIVITY
PERIPHERALS
CONNECTIVITY
IP 65 MODELS & CONNECTIVITY
POWER SUPPLIES & SHUNTS
GEAR HEADS
SOFTWARE
APPENDIX

DIMENSION "L"

Single Stage = 2.869±.015
Double Stage = 3.738±.015

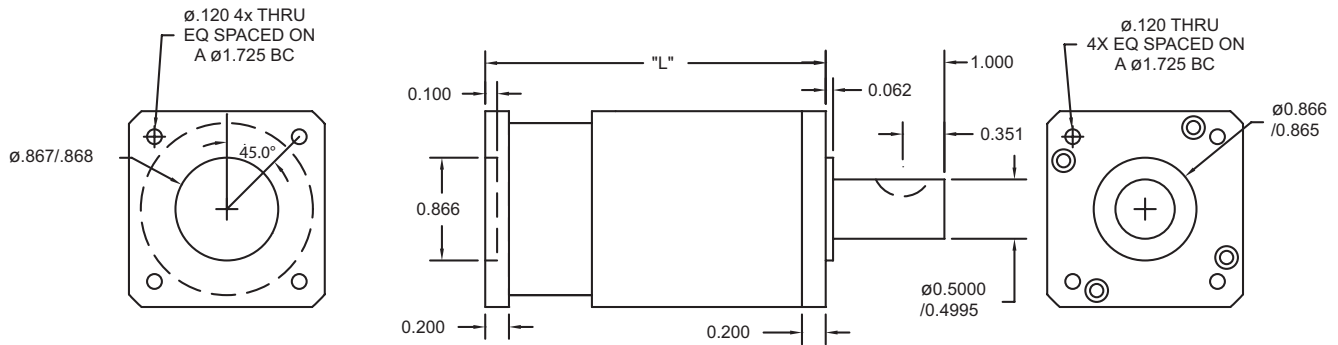

NOTE: Dimensions in Inches

Part #	Ratio	Continuous output torque at 1500 rpm input (in-lbs)	Continuous output torque at 3500 rpm input (in-lbs)	Continuous output torque at 5000 rpm input (in-lbs)	Gearhead inertia at input (lb-in-sec ²)
Single Stage					
GH17P3	3:1	197	140	115	3.25 x 10 ⁻⁵
GH17P4	4:1	177	136	116	1.60 x 10 ⁻⁵
GH17P5.5	5.5:1	157	129	113	1.10 x 10 ⁻⁵
GH17P7	7:1	143	122	110	9.56 x 10 ⁻⁶
GH17P10	10:1	113	101	93	8.36 x 10 ⁻⁶
Double Stage					
GH17P16	16:1	211	194	182	1.59 x 10 ⁻⁵
GH17P22	22:1	216	201	193	1.10 x 10 ⁻⁶
GH17P28	28:1	218	207	199	9.54 x 10 ⁻⁶
GH17P40	40:1	220	212	207	8.35 x 10 ⁻⁶
GH17P49	49:1	158	154	152	9.44 x 10 ⁻⁶
GH17P55	55:1	183	177	175	8.31 x 10 ⁻⁶
GH17P70	70:1	160	156	154	8.30 x 10 ⁻⁶
GH17P100	100:1	122	120	119	8.29 x 10 ⁻⁶

General Specifications

Construction Type	Ratio	Standard Backlash (arc-minutes)	Low Backlash (arc-minutes)	Efficiency	Weight (lbs)	Maximum Tested Input rpm
Single Stage	3:1 to 10:1	6	3	90%	1.14	5000
Double Stage	16:1 to 100:1	10	7	85%	1.62	5000

PEAK TORQUE: 15% above continuous rating. **NOTE:** Repeated peak torque loading may cause failure.

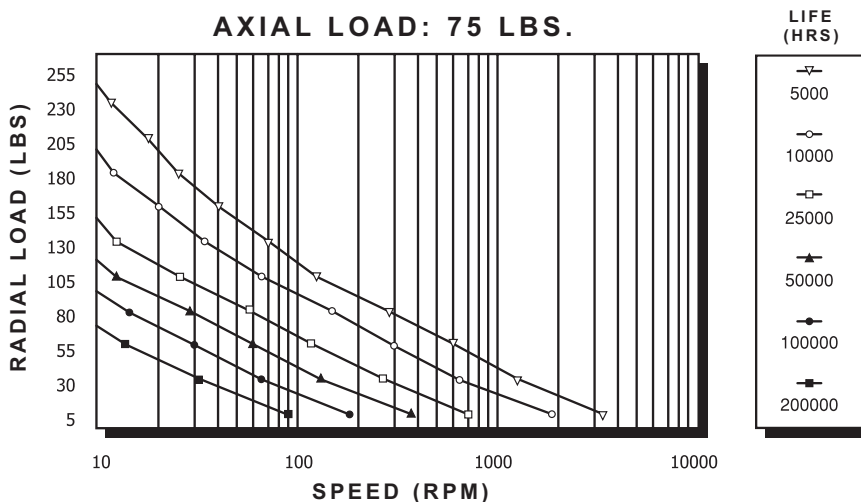
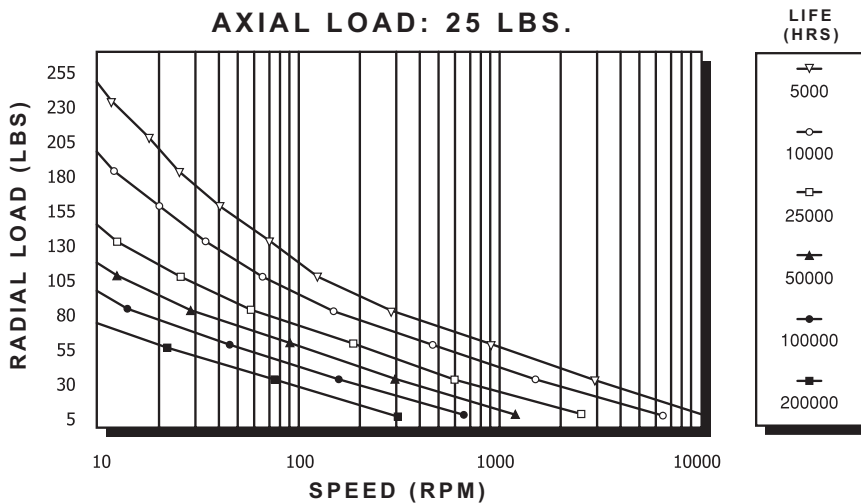
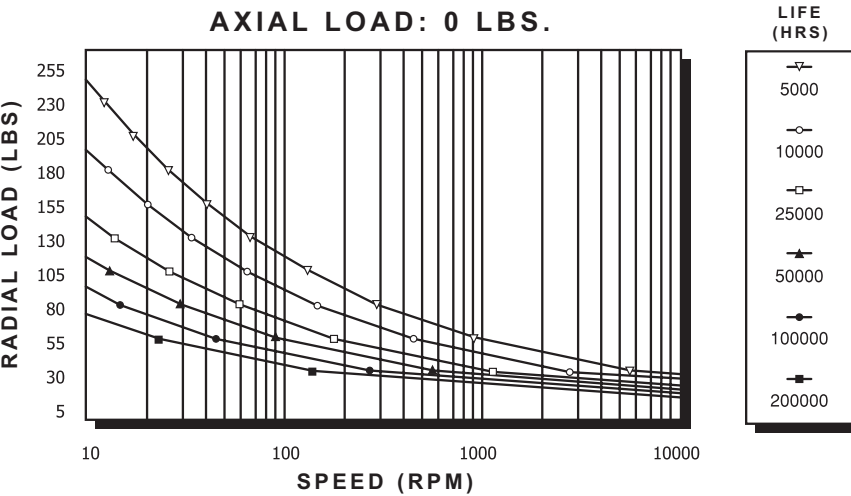

SPEED (RPM) refers to the gearheads output shaft speed.

LIFE (HRS) = (# of lifetime revolutions) ÷ (60 x rpm)

F_{RADIAL} is calculated at 1/2 the shaft length.

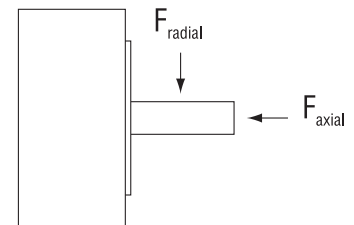

OVERVIEW
MOTOR SPECIFICATIONS
LINEAR SYSTEMS
CONNECTIVITY
PERIPHERALS
IP 65 MODELS & CONNECTIVITY
POWER SUPPLIES & SHUNTS
GEAR HEADS
SOFTWARE
APPENDIX

DIMENSION "L"

Single Stage (3:1 to 10:1) = $3.146 \pm .015$
 Double Stage (16:1 to 100:1) = $4.249 \pm .015$

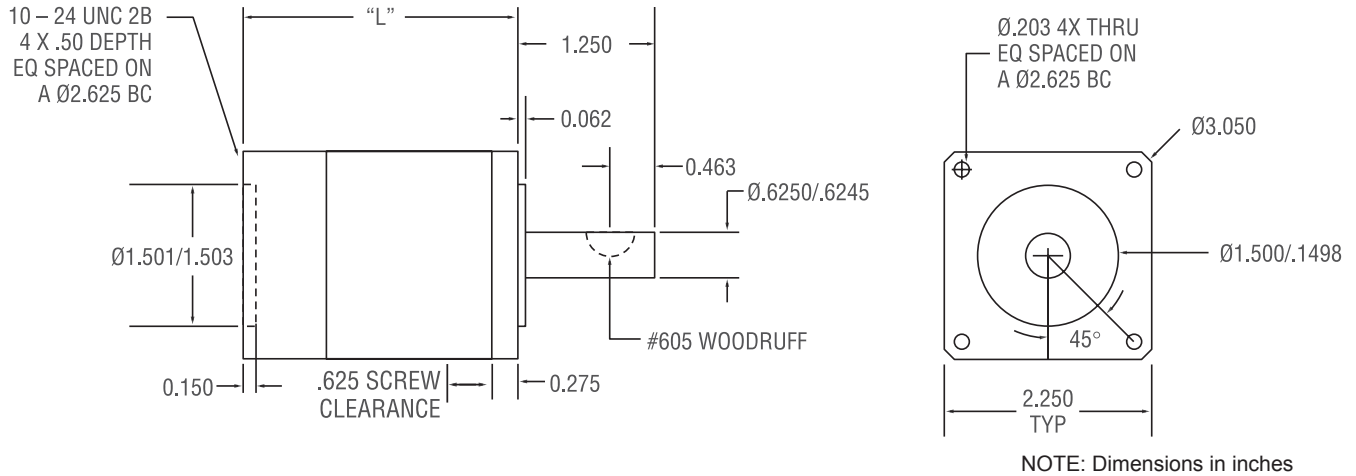

Part #	Ratio	Continuous output torque at 1500 rpm input (in-lbs)	Continuous output torque at 3500 rpm input (in-lbs)	Continuous output torque at 5000 rpm input (in-lbs)	Gearhead inertia at input (lb-in-sec ²)
Single Stage					
GH23P3	3:1	442	292	232	1.22×10^{-4}
GH23P4	4:1	410	294	242	5.24×10^{-5}
GH23P5.5	5.5:1	373	288	247	2.65×10^{-5}
GH23P7	7:1	344	279	245	1.93×10^{-5}
GH23P10	10:1	277	238	215	1.35×10^{-5}
Double Stage					
GH23P16	16:1	521	463	427	5.32×10^{-5}
GH23P22	22:1	536	490	460	2.70×10^{-5}
GH23P28	28:1	545	506	481	1.96×10^{-5}
GH23P40	40:1	553	525	506	1.36×10^{-5}
GH23P49	49:1	400	385	375	1.90×10^{-5}
GH23P55	55:1	460	443	432	1.34×10^{-5}
GH23P70	70:1	404	393	385	1.33×10^{-5}
GH23P100	100:1	308	303	298	1.33×10^{-5}

General Specifications

Construction Type	Ratio	Standard Backlash (arc-minutes)	Low Backlash (arc-minutes)	Efficiency	Weight (lbs)	Maximum Tested Input rpm
Single Stage	3:1 to 10:1	6	3	90%	2.29	5000
Double Stage	16:1 to 100:1	10	7	85%	3.42	5000

PEAK TORQUE: 15% above continuous rating. **NOTE:** Repeated peak torque loading may cause failure.

WARNING: Gearheads on this page not compatible with SM23165M and SM23165MT

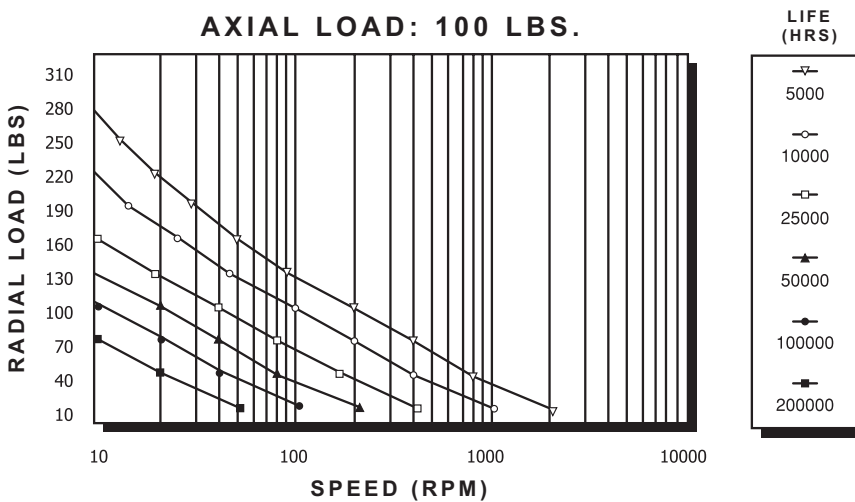
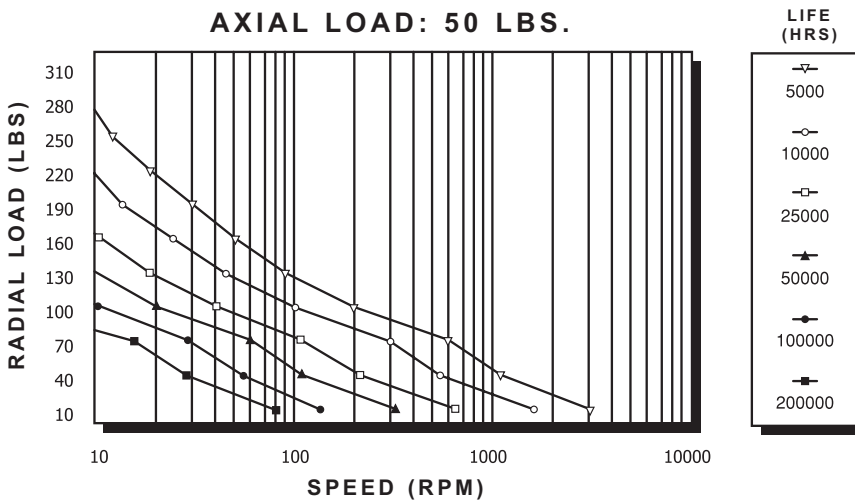
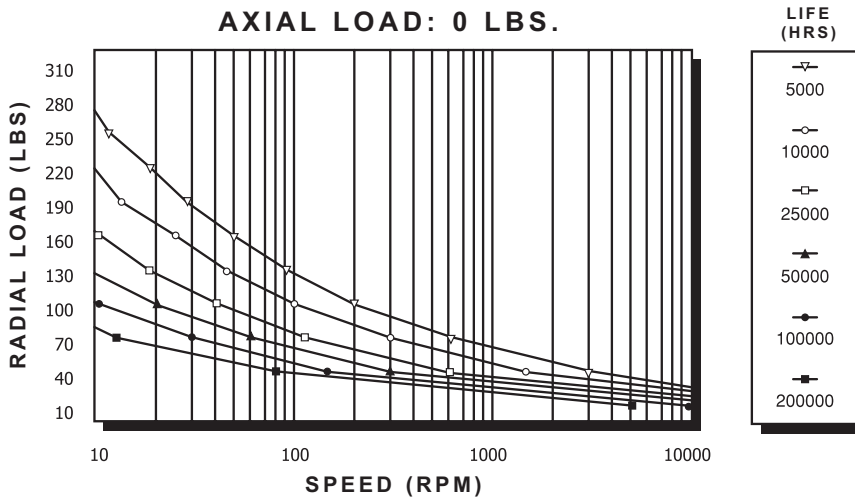

SPEED (RPM) refers to the gearheads output shaft speed.

LIFE (HRS) = (# of lifetime revolutions) ÷ (60 x rpm)

F_{RADIAL} is calculated at 1/2 the shaft length.

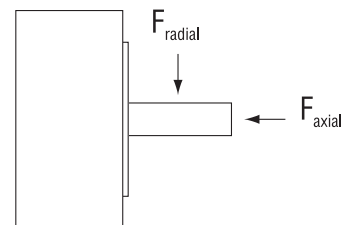

OVERVIEW
MOTOR SPECIFICATIONS
LINEAR SYSTEMS
CONNECTIVITY
PERIPHERALS
CONNECTIVITY
IP 65 MODELS & CONNECTIVITY
POWER SUPPLIES & SHUNTS
GEAR HEADS
SOFTWARE
APPENDIX

DIMENSION "L"

Single Stage (3:1 to 10:1) = 4.063 ± .015

Double Stage (16:1 to 100:1) = 5.431 ± .015

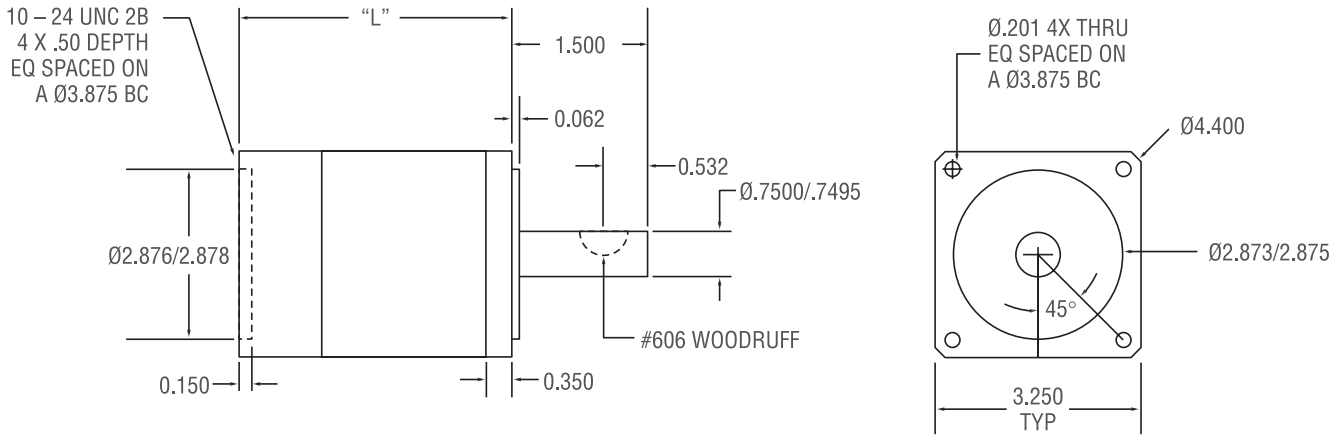

Part #	Ratio	Continuous output torque at 1500 rpm input (in-lbs)	Continuous output torque at 3500 rpm input (in-lbs)	Continuous output torque at 5000 rpm input (in-lbs)	Gearhead inertia at input (lb-in-sec ²)
Single Stage					
GH34P3	3:1	1010	615	475	6.77 x 10 ⁻⁴
GH34P4	4:1	972	643	513	2.77 x 10 ⁻⁴
GH34P5.5	5.5:1	913	657	543	1.51 x 10 ⁻⁴
GH34P7	7:1	859	653	554	1.11 x 10 ⁻⁴
GH34P10	10:1	707	575	505	7.90 x 10 ⁻⁵
Double Stage					
GH34P16	16:1	1350	1145	1027	2.86 x 10 ⁻⁴
GH34P22	22:1	1401	1234	1133	1.55 x 10 ⁻⁴
GH34P28	28:1	1432	1293	1203	1.11 x 10 ⁻⁴
GH34P40	40:1	1469	1362	1293	8.04 x 10 ⁻⁵
GH34P49	49:1	1067	1010	971	1.11 x 10 ⁻⁴
GH34P55	55:1	1228	1165	1123	7.94 x 10 ⁻⁵
GH34P70	70:1	1081	1040	1010	7.90 x 10 ⁻⁵
GH34P100	100:1	827	805	790	7.87 x 10 ⁻⁵

⚠ WARNING - Please read when using with SM34165DT and SM34165MT Series Motor:
 All gearheads above come standard with 3/8 inch diameter input shaft. For Gearheads which require 0.5 inch shaft input, please add "-0.5" to part number. Example: GH34P3-0.5 will give you a half inch input shaft diameter.

General Specifications

Construction Type	Ratio	Standard Backlash (arc-minutes)	Low Backlash (arc-minutes)	Efficiency	Weight (lbs)	Maximum Tested Input rpm
Single Stage	3:1 to 10:1	6	3	90%	5.67	5000
Double Stage	16:1 to 100:1	10	7	85%	8.41	5000

PEAK TORQUE: 15% above continuous rating. **NOTE:** Repeated peak torque loading may cause failure.

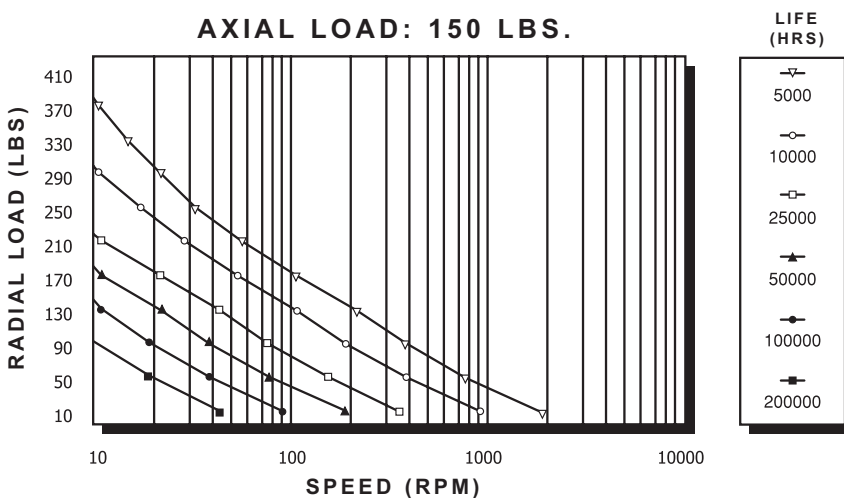
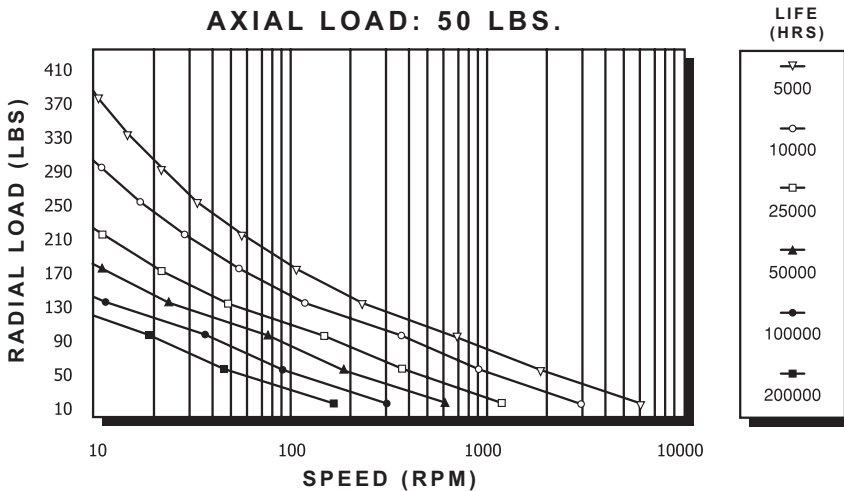
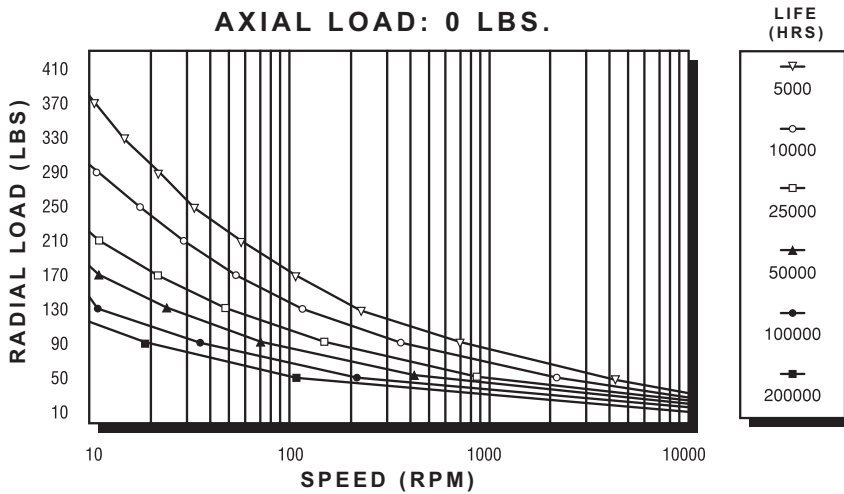

SPEED (RPM) refers to the gearheads output shaft speed.

LIFE (HRS) = (# of lifetime revolutions) ÷ (60 x rpm)

F_{RADIAL} is calculated at 1/2 the shaft length.

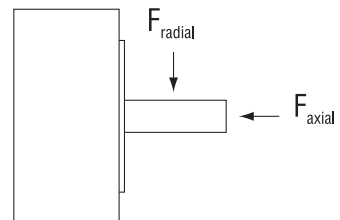

OVERVIEW
MOTOR SPECIFICATIONS
LINEAR SYSTEMS
CONNECTIVITY
PERIPHERALS
CONNECTIVITY
IP 65 MODELS & CONNECTIVITY
POWER SUPPLIES & SHUNTS
GEAR HEADS
SOFTWARE
APPENDIX

DIMENSION "L"
Single Stage (4:1 to 10:1) = 2.17± .015
Double Stage (16:1 to 100:1) = 2.78 ± .015

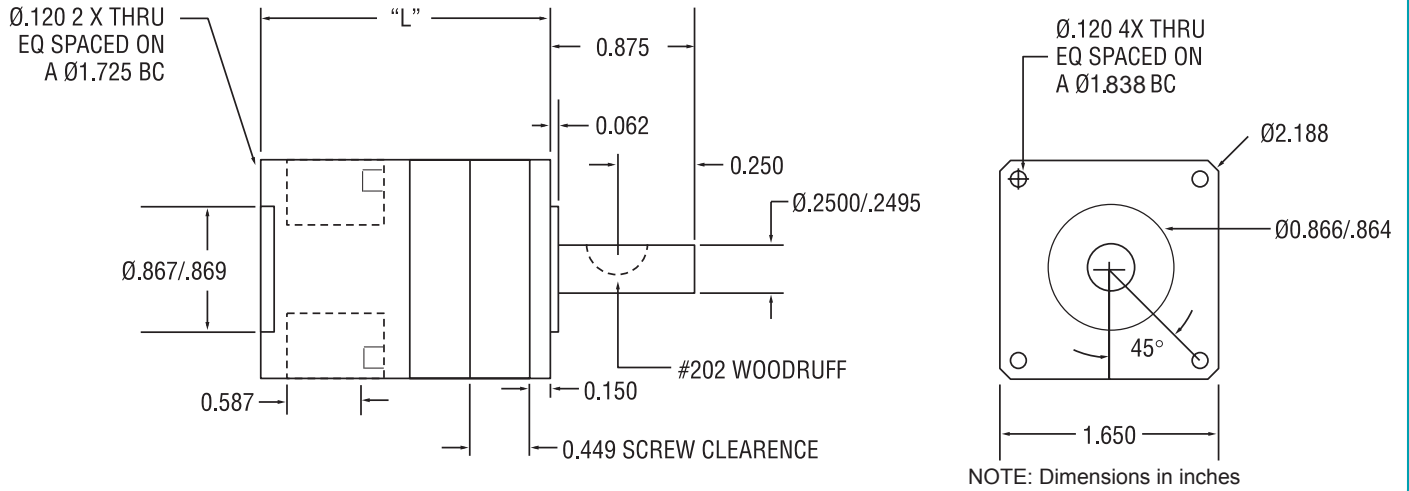

Part #	Ratio	Continuous output torque at 1500 rpm input (in-lbs)	Continuous output torque at 3500 rpm input (in-lbs)	Continuous output torque at 5000 rpm input (in-lbs)	Gearhead inertia at input (lb-in-sec ²)
Single Stage					
GH17SP004	4:1	75	57	49	1.28 x 10 ⁻⁵
GH17SP007	7:1	60	51	46	7.65 x 10 ⁻⁶
GH17SP010	10:1	48	43	39	6.69 x 10 ⁻⁶
Double Stage					
GH17SP016	16:1	81	74	70	1.27 x 10 ⁻⁵
GH17SP028	28:1	83	79	76	7.63 x 10 ⁻⁶
GH17SP049	49:1	61	59	58	7.55 x 10 ⁻⁶
GH17SP070	70:1	61	60	59	6.64 x 10 ⁻⁶
GH17SP100	100:1	47	46	46	6.63 x 10 ⁻⁶

General Specifications

Construction Type	Ratio	Standard Backlash (arc-minutes)	Low Backlash (arc-minutes)	Efficiency	Weight (lbs)	Maximum Tested Input rpm
Single Stage	4:1 to 10:1	12	6	95%	0.59	5000
Double Stage	16:1 to 100:1	16	10	90%	0.88	5000

PEAK TORQUE: 15% above continuous rating. **NOTE:** Repeated peak torque loading may cause failure.

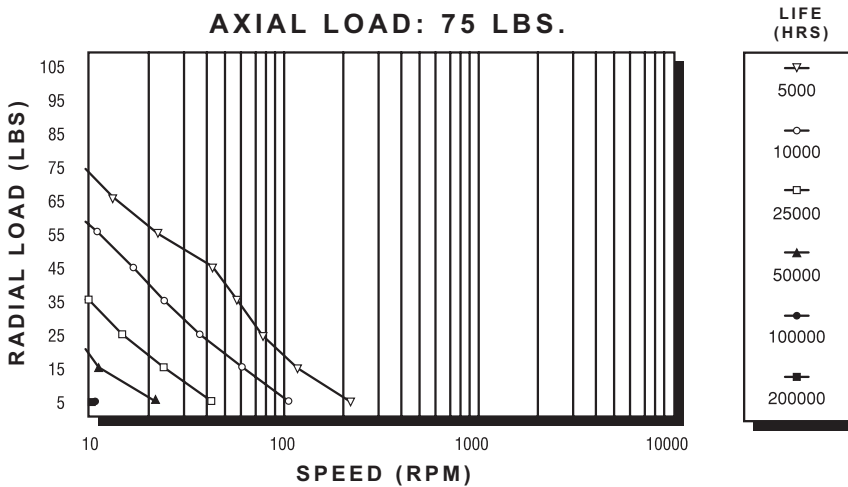
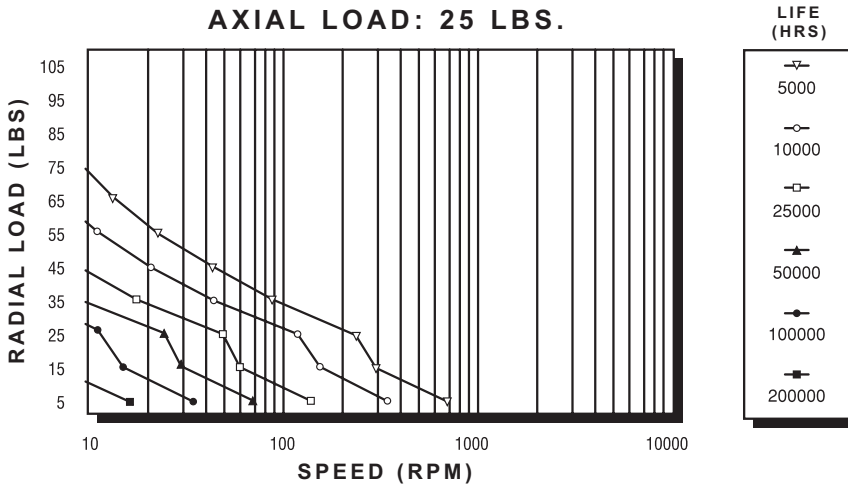
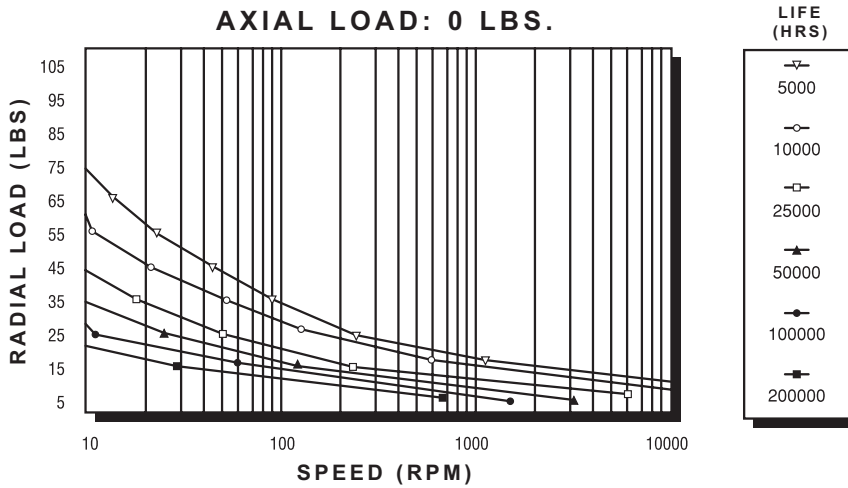

SPEED (RPM) refers to the gearheads output shaft speed.

LIFE (HRS) = (# of lifetime revolutions) ÷ (60 x rpm)

F_{RADIAL} is calculated at 1/2 the shaft length.

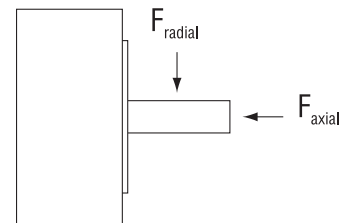

OVERVIEW
MOTOR SPECIFICATIONS
LINEAR SYSTEMS
CONNECTIVITY
PERIPHERALS
CONNECTIVITY
IP 65 MODELS & CONNECTIVITY
POWER SUPPLIES & SHUNTS
GEAR HEADS
SOFTWARE
APPENDIX

DIMENSION "L"

Single Stage (4:1 to 10:1) = 2.436 ± .015
Double Stage (16:1 to 100:1) = 3.029 ± .015

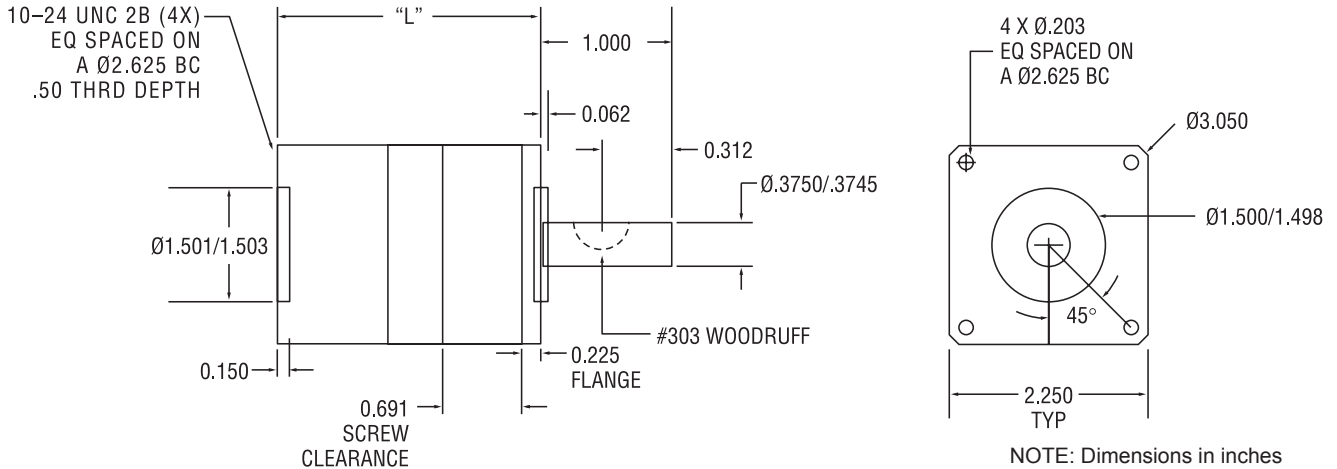

Part #	Ratio	Continuous output torque at 1500 rpm input (in-lbs)	Continuous output torque at 3500 rpm input (in-lbs)	Continuous output torque at 5000 rpm input (in-lbs)	Gearhead inertia at input (lb-in-sec ²)
Single Stage					
GH23SP004	4:1	185	133	109	4.19 x 10 ⁻⁵
GH23SP007	7:1	155	126	110	1.54 x 10 ⁻⁵
GH23SP010	10:1	125	107	97	1.08 x 10 ⁻⁵
Double Stage					
GH23SP016	16:1	214	190	175	4.26 x 10 ⁻⁵
GH23SP028	28:1	223	208	197	1.57 x 10 ⁻⁵
GH23SP049	49:1	164	158	154	1.52 x 10 ⁻⁵
GH23SP070	70:1	166	161	158	1.06 x 10 ⁻⁵
GH23SP100	100:1	126	124	122	1.06 x 10 ⁻⁵

General Specifications

Construction Type	Ratio	Standard Backlash (arc-minutes)	Low Backlash (arc-minutes)	Efficiency	Weight (lbs)	Maximum Tested Input rpm
Single Stage	4:1 to 10:1	12	6	95%	1.55	5000
Double Stage	16:1 to 100:1	16	10	90%	1.95	5000

PEAK TORQUE: 15% above continuous rating. **NOTE:** Repeated peak torque loading may cause failure.

WARNING: Gearheads on this page not compatible with SM23165M and SM23165MT

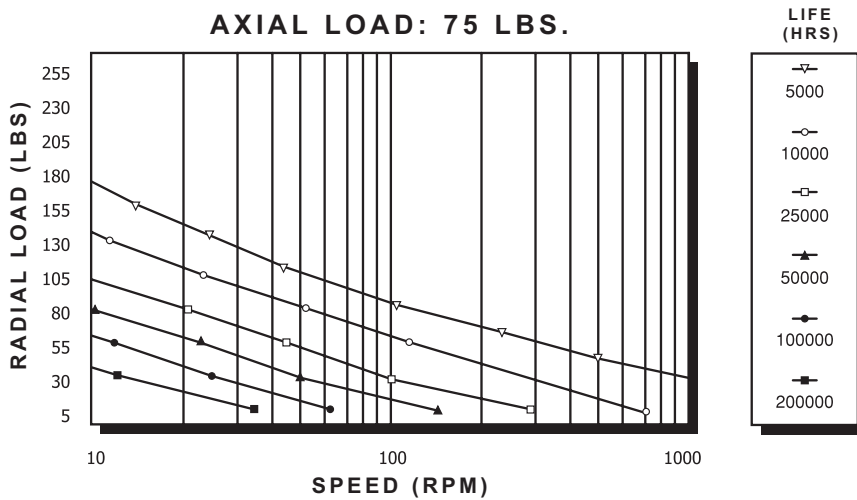
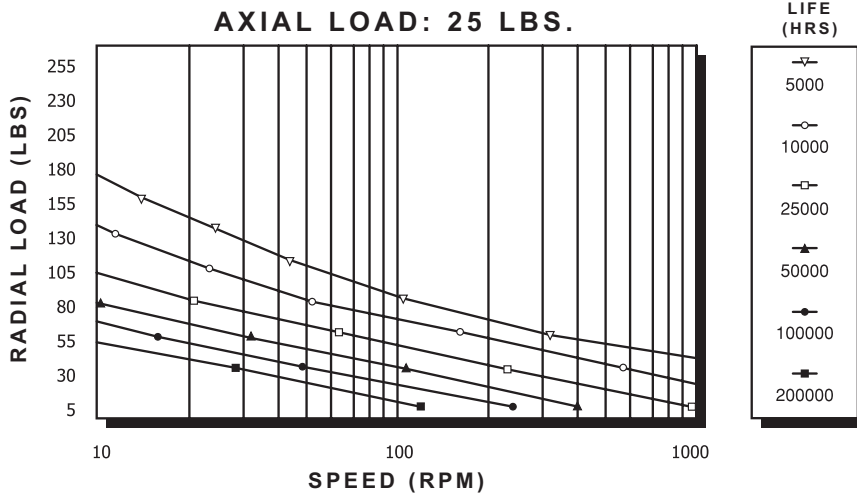
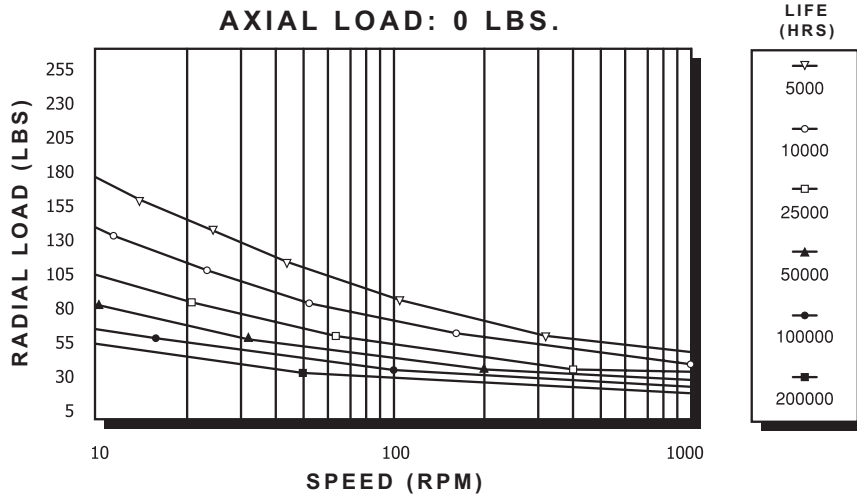

SPEED (RPM) refers to the gearheads output shaft speed.

LIFE (HRS) = (# of lifetime revolutions) ÷ (60 x rpm)

F_{RADIAL} is calculated at 1/2 the shaft length.

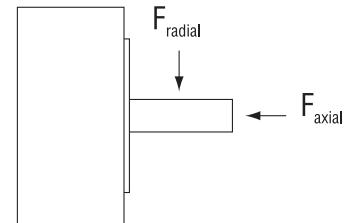

OVERVIEW
MOTOR SPECIFICATIONS
LINEAR SYSTEMS
CONNECTIVITY
PERIPHERALS
IP 65 MODELS & CONNECTIVITY
POWER SUPPLIES & SHUNTS
GEAR HEADS
SOFTWARE
APPENDIX

DIMENSION "L"

Single Stage (4:1 to 10:1) = 3.229 ± .015
Double Stage (16:1 to 100:1) = 4.087 ± .015

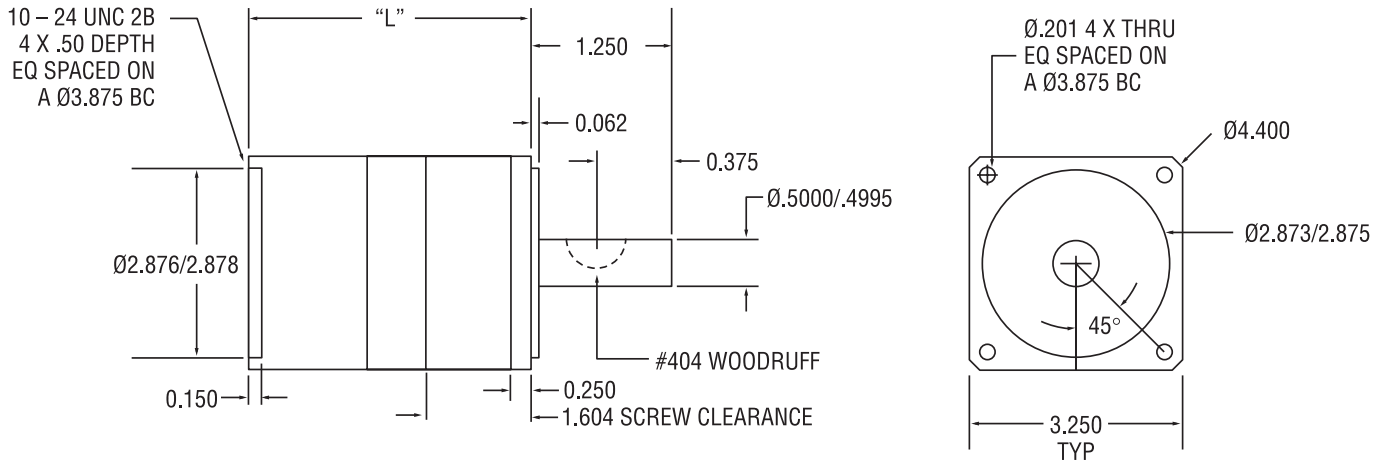

NOTE: Dimensions in inches

Part #	Ratio	Continuous output torque at 1500 rpm input (in-lbs)	Continuous output torque at 3500 rpm input (in-lbs)	Continuous output torque at 5000 rpm input (in-lbs)	Gearhead inertia at input (lb-in-sec ²)
Single Stage					
GH34SP004	4:1	529	350	279	1.28 x 10 ⁻⁴
GH34SP007	7:1	467	355	301	7.65 x 10 ⁻⁵
GH34SP010	10:1	384	313	275	6.69 x 10 ⁻⁵
Double Stage					
GH34SP016	16:1	667	566	508	1.27 x 10 ⁻⁴
GH34SP028	28:1	670	639	595	7.63 x 10 ⁻⁵
GH34SP049	49:1	528	499	480	7.55 x 10 ⁻⁵
GH34SP070	70:1	534	514	499	6.64 x 10 ⁻⁵
GH34SP100	100:1	409	398	391	6.63 x 10 ⁻⁵

⚠ WARNING - Please read when using with SM34165DT and SM34165MT Series Motor:
All gearheads above come standard with 3/8 inch diameter input shaft. For gearheads which require 0.5 inch shaft input, please add "-0.5" to part number. Example: GH34SP004-0.5 will give you a half inch input shaft diameter.

General Specifications

Construction Type	Ratio	Standard Backlash (arc-minutes)	Low Backlash (arc-minutes)	Efficiency	Weight (lbs)	Maximum Tested Input rpm
Single Stage	4:1 to 10:1	12	6	95%	3.67	5000
Double Stage	16:1 to 100:1	16	10	90%	5.10	5000

PEAK TORQUE: 15% above continuous rating. **NOTE:** Repeated peak torque loading may cause failure.

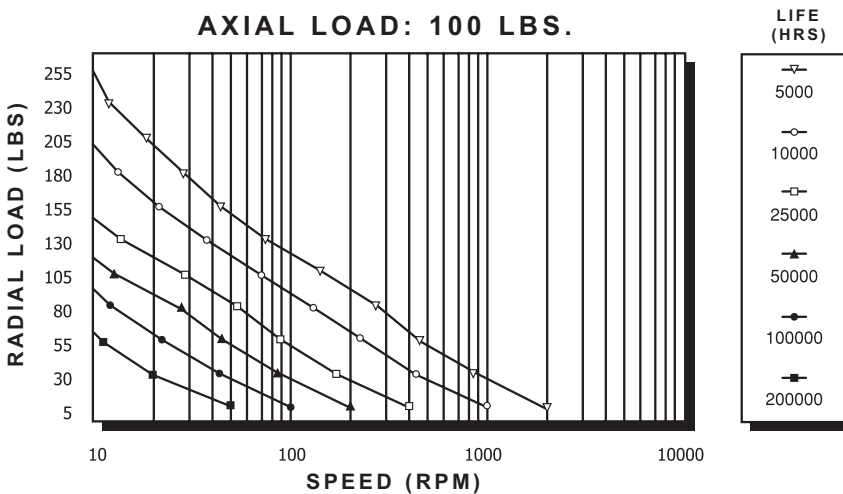
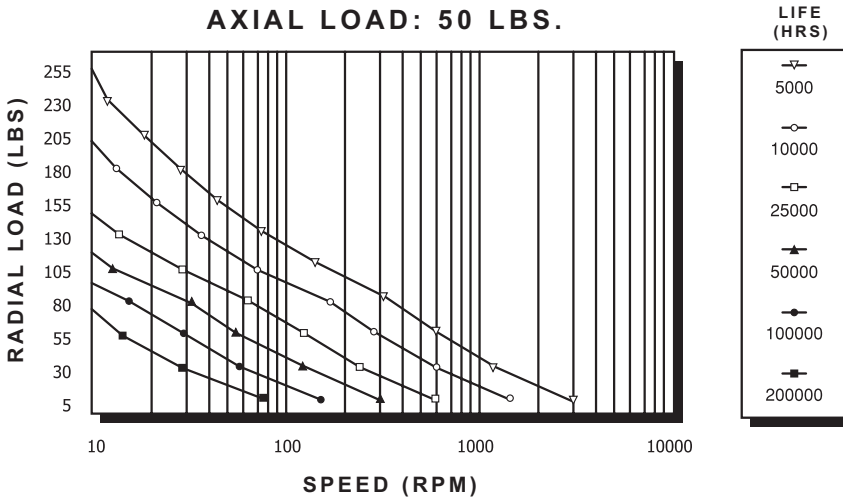
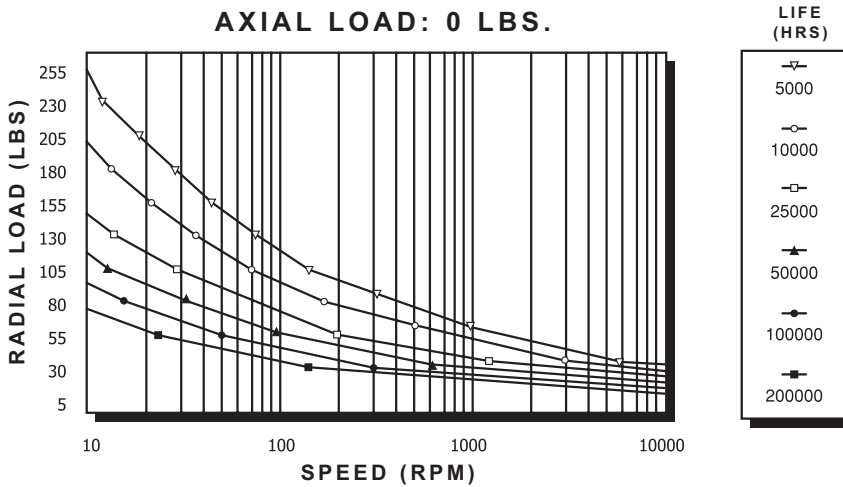

SPEED (RPM) refers to the gearheads output shaft speed.

LIFE (HRS) = (# of lifetime revolutions) ÷ (60 x rpm)

F_{RADIAL} is calculated at 1/2 the shaft length.

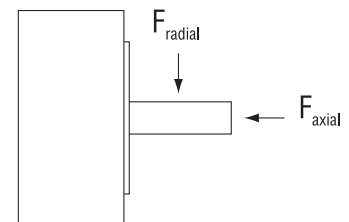

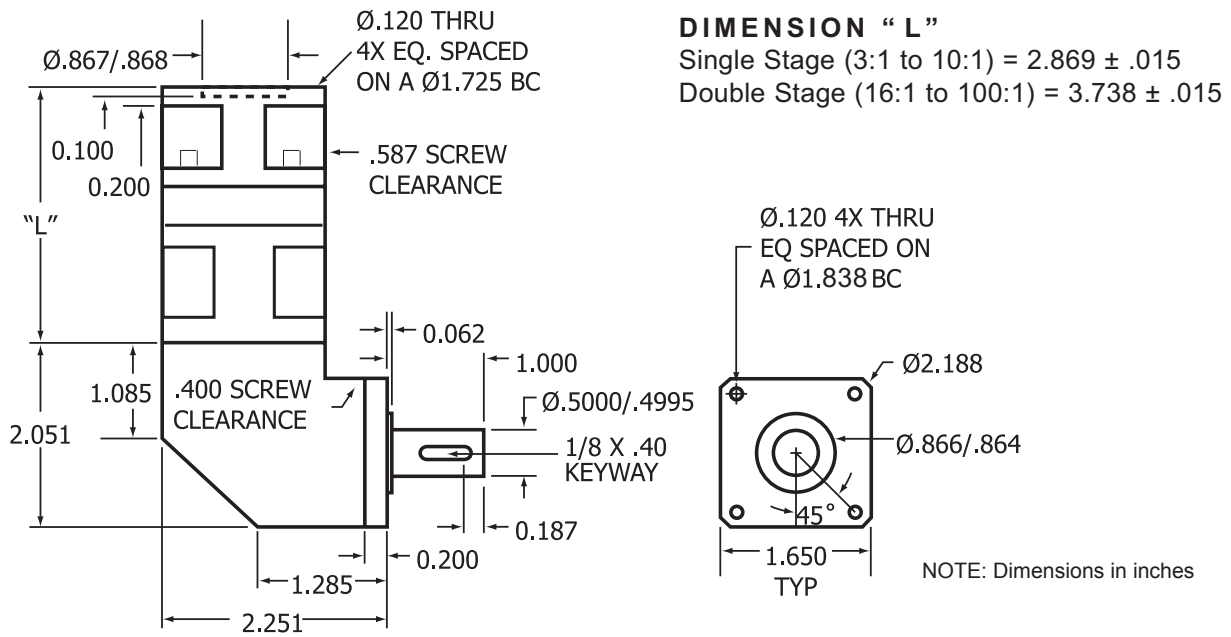

Part #	Ratio	Continuous output torque at 1500 rpm input (in-lbs)	Continuous output torque at 3500 rpm input (in-lbs)	Continuous output torque at 5000 rpm input (in-lbs)	Gearhead inertia at input (lb-in-sec ²)
Single Stage					
GH17RAP3	3:1	80	80	80	4.96 x 10 ⁻⁵
GH17RAP5.5	5.5:1	80	80	80	1.61 x 10 ⁻⁵
GH17RAP7	7:1	80	80	80	1.27 x 10 ⁻⁵
GH17RAP10	10:1	80	80	80	9.90 x 10 ⁻⁶
Double Stage					
GH17RAP16	16:1	100	100	100	1.65 x 10 ⁻⁵
GH17RAP22	22:1	100	100	100	1.13 x 10 ⁻⁵
GH17RAP55	55:1	100	100	100	8.36 x 10 ⁻⁶
GH17RAP100	100:1	100	100	100	8.31 x 10 ⁻⁶

Construction Type	Ratio	Standard Backlash (arc-minutes)	Low Backlash (arc-minutes)	Efficiency	Weight (lbs)	Maximum Tested Input rpm
Single Stage	3:1 to 10:1	10	7	90%	1.96	5000
Double Stage	16:1 to 100:1	14	11	85%	2.44	5000

PEAK TORQUE: 15% above continuous rating. **NOTE:** Repeated peak torque loading may cause failure.

OVERVIEW
MOTOR SPECIFICATIONS
LINEAR SYSTEMS
CONNECTIVITY
PERIPHERALS
CONNECTIVITY
IP 65 MODELS & CONNECTIVITY
POWER SUPPLIES & SHUNTS
GEAR HEADS
SOFTWARE
APPENDIX

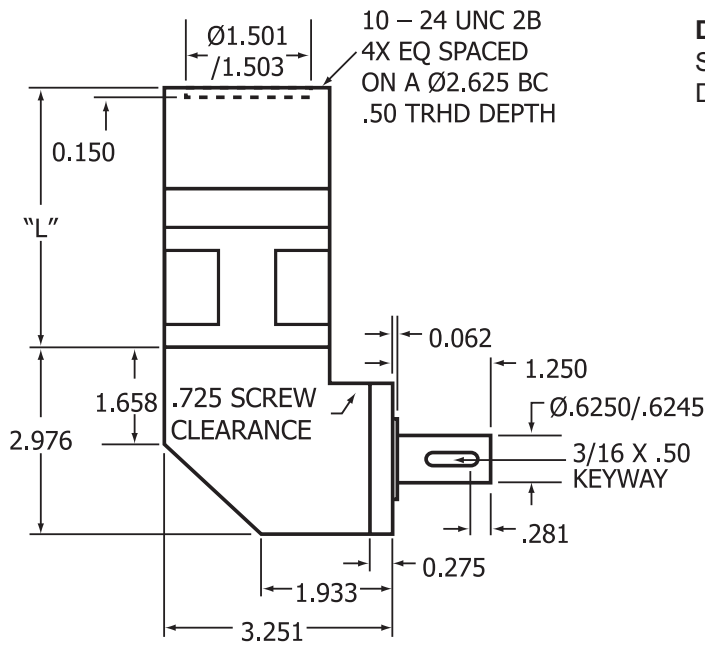

DIMENSION "L"

Single Stage (3:1 to 10:1) = $3.146 \pm .015$
 Double Stage (16:1 to 100:1) = $4.249 \pm .015$

Part #	Ratio	Continuous output torque at 1500 rpm input (in-lbs)	Continuous output torque at 3500 rpm input (in-lbs)	Continuous output torque at 5000 rpm input (in-lbs)	Gearhead inertia at input (lb-in-sec ²)
Single Stage					
GH23RAP3	3:1	280	280	232	2.94×10^{-4}
GH23RAP5.5	5.5:1	280	280	247	7.77×10^{-5}
GH23RAP10	10:1	277	238	215	2.90×10^{-5}
Double Stage					
GH23RAP16	16:1	350	350	350	5.93×10^{-5}
GH23RAP22	22:1	350	350	350	3.02×10^{-5}
GH23RAP55	55:1	350	350	350	1.39×10^{-5}
GH23RAP100	100:1	308	303	298	1.35×10^{-5}

Construction Type	Ratio	Standard Backlash (arc-minutes)	Low Backlash (arc-minutes)	Efficiency	Weight (lbs)	Maximum Tested Input rpm
Single Stage	3:1 to 10:1	10	7	90%	4.87	5000
Double Stage	16:1 to 100:1	14	11	85%	6.00	5000

PEAK TORQUE: 15% above continuous rating. **NOTE:** Repeated peak torque loading may cause failure.

WARNING: Gearheads on this page not compatible with SM23165M and SM23165MT

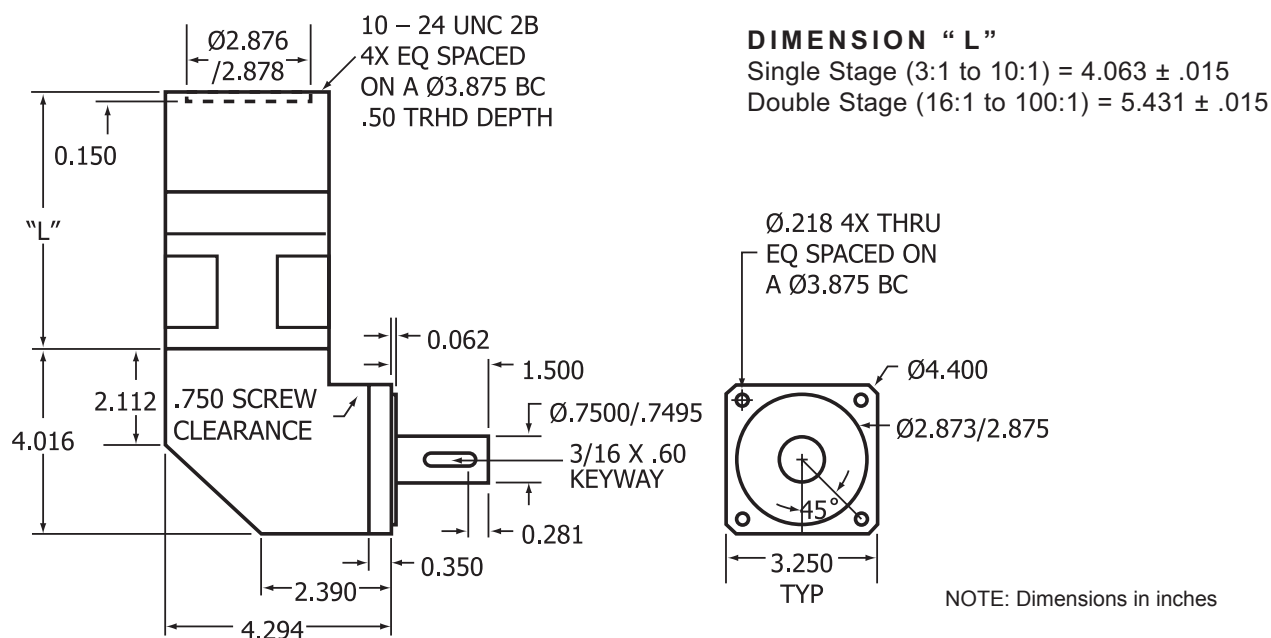

Part #	Ratio	Continuous output torque at 1500 rpm input (in-lbs)	Continuous output torque at 3500 rpm input (in-lbs)	Continuous output torque at 5000 rpm input (in-lbs)	Gearhead inertia at input (lb-in-sec ²)
Single Stage					
GH34RAP3	3:1	525	525	475	1.20 x 10 ⁻³
GH34RAP5.5	5.5:1	525	525	525	3.08 x 10 ⁻⁴
GH34RAP10	10:1	525	525	505	1.26 x 10 ⁻⁴
Double Stage					
GH34RAP16	16:1	656	656	656	3.05 x 10 ⁻⁴
GH34RAP22	22:1	656	656	656	1.65 x 10 ⁻⁴
GH34RAP55	55:1	656	656	656	8.10 x 10 ⁻⁵
GH34RAP100	100:1	656	656	656	7.92 x 10 ⁻⁵

⚠ WARNING - Please read when using with SM34165DT and SM34165MT Series Motor:
All gearheads above come standard with 3/8 inch diameter input shaft. For gearheads which require 0.5 inch shaft input, please add "-0.5" to part number. Example: GH34RAP3-0.5 will give you a half inch input shaft diameter.

Construction Type	Ratio	Standard Backlash (arc-minutes)	Low Backlash (arc-minutes)	Efficiency	Weight (lbs)	Maximum Tested Input rpm
Single Stage	3:1 to 10:1	10	7	90%	11.89	5000
Double Stage	16:1 to 100:1	14	11	85%	14.62	5000

PEAK TORQUE: 15% above continuous rating. **NOTE:** Repeated peak torque loading may cause failure.

Animatics SmartMotor Software

SMI (SmartMotor Interface) is used for communicating with SmartMotor servos and developing downloadable code and SMI includes many tools for diagnostics.

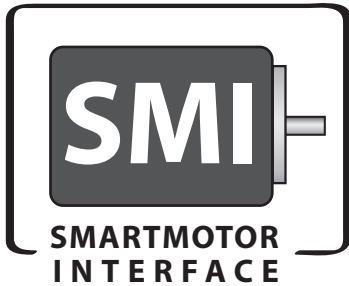

Animatics recently introduced **SmartSizer™**, a new load sizing software tool to aid in SmartMotor selection for any given load.

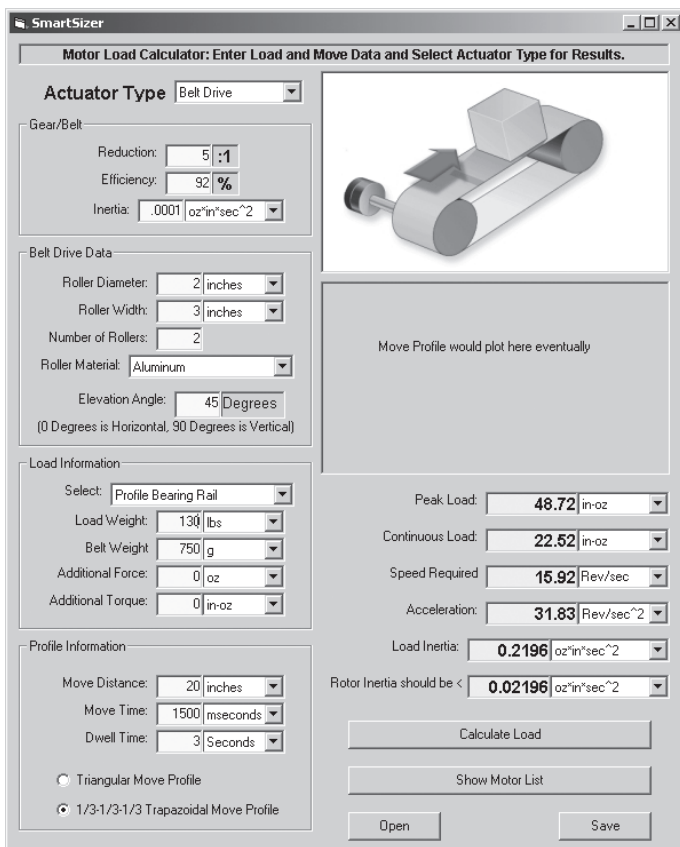

In one simple, single page format, the tool allows the user to fill in values to calculate load torque imposed on a given motor. All input data has a drop down unit selection, allowing you to easily mix and match standard and metric units together.

SMNC (SmartMotor Numerical Control) is a CNC based package that has been upgraded to interface with newer Class 5 SmartMotor servos over CANopen CIA 402 IP (Interpolation protocol).



With Class 5 SmartMotor servos and 1MB bandwidth CANopen interfacing, SmartMotor position data packets may be updated at sub-millisecond rates allowing Class 5 SmartMotor servos to be used in high speed CNC systems such as laser engraving and micro machining.



SMI Engine The SMI Engine is a .dll file that comes free with any SMI software download and install and is an active support tool for C and VB programmers. The IntegMotorInterface.dll file may be used with Microsoft, Borland, Python and other compilers as well as used as an Active X add-in in Labview.

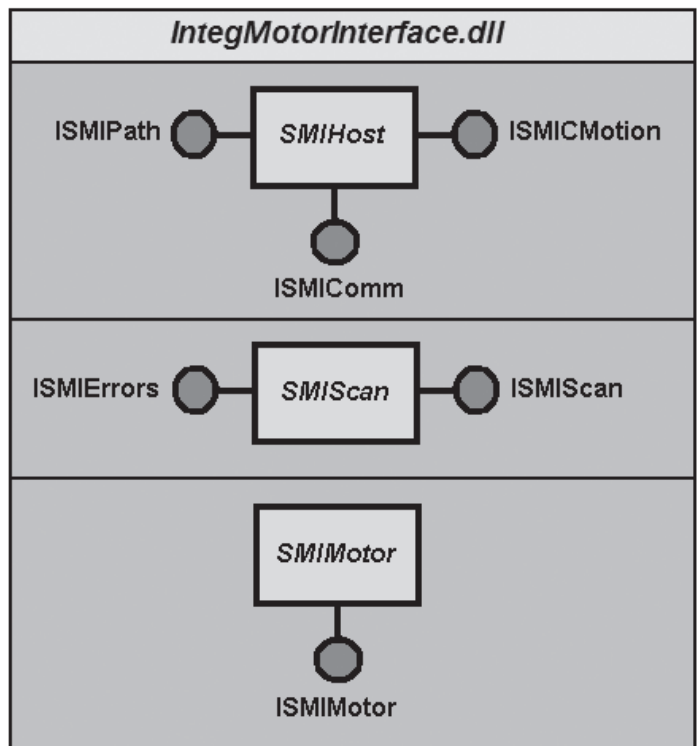

OVERVIEW
MOTOR SPECIFICATIONS
LINEAR SYSTEMS
CONNECTIVITY
PERIPHERALS
IP 65 MODELS & CONNECTIVITY
POWER SUPPLIES & SHUNTS
GEAR HEADS
SOFTWARE
APPENDIX

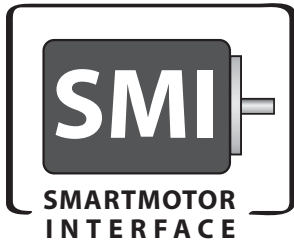

Free Download from Website

Animatics' SMI™ software provides an easy-to-use Microsoft Windows compatible interface to your Animatics SmartMotor™. Using SMI, you can define multi-axis motion control for 1 to 100 SmartMotor. SMI includes a terminal program, program editor, and source level debugger.

Standard SMI features include a Tools menu to set PID tuning parameters and plot the step response, motor info and dynamic status tracking, and online help and documentation. The latest release of SMI can open multiple windows for program editing, instantly address multiple motors, and upload programs from

motors. Simply write and download your application to the configured SmartMotor and reboot the motor to start your application working.

Download SMI at no cost from the Animatics web site (www.animatics.com) or from the product CD-ROM, and use the installation wizard to install SMI, SMIEngine™, and Coordinated Motion.

Features in SMI

The latest release of SMI adds extensive user interface improvements, functional enhancements, and new utilities that help you develop, test, run, and deploy your Animatics SmartMotor™ applications.

Projects Feature. Do you need to put an SMI project on hold? You can save your communications, configuration, and preferences settings with the new Project option. The Project menu option allows you to manage and save your workspace settings and applications configuration settings.

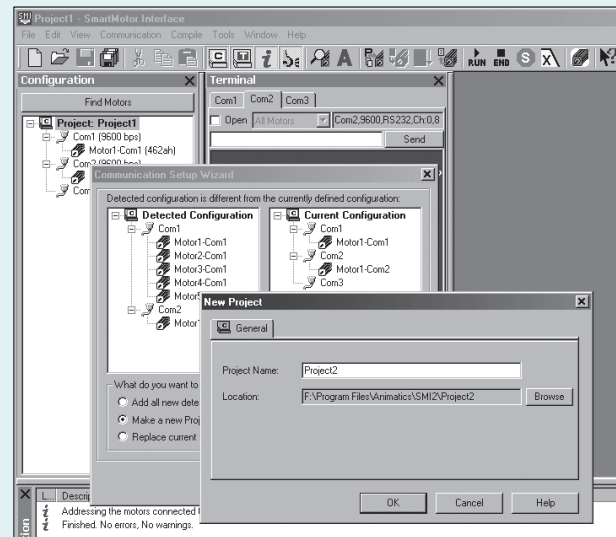

Communications with Ethernet, CANopen, RS-232 and RS-485 SmartMotor™

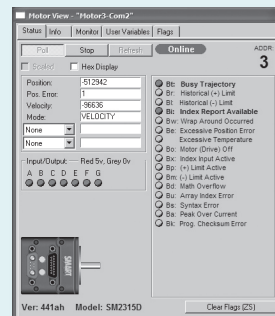
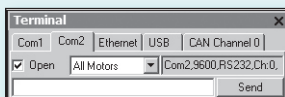

The Polling Window

Interface has special user-defined polling features to help you monitor important functions conveniently. Monitor different status bits, variables, and I/O from any motor in a chain, even during application execution.

The **Information window** displays error and information messages and allows you to go directly to the message's source location.

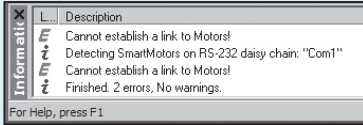

```
UCI      'set port C as input
V=100000 'set speed
A=100    'set accel
MV       'set to velocity mode
G
WHILE Bt
  IF Bo
    BREAK
  ENDF
LOOP
END
```

Editor window
Uses different colors for different code elements, such as keywords or comments

The **Terminal** window creates a tabbed page for each port so you can communicate with individual or multiple SmartMotor™.

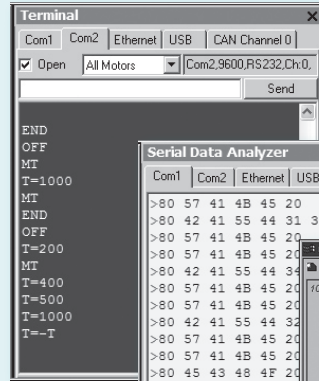

The **Serial Data Analyzer** displays data transfers between your computer and Animatics SmartMotor™. You can filter the data to display only the information you want; for example, choose to display transmitted data, received data, or echoed data.

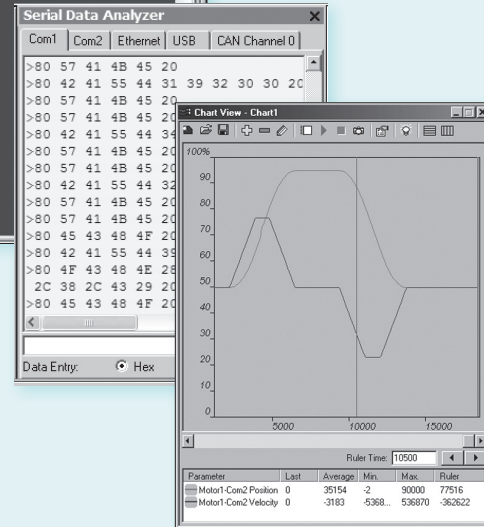

The **Chart View** is a collection of user-defined motor parameters (Chart Items) that you can select to monitor during motor operation in a dynamic graphical display.

SmartMotor™ Playground. Would you like to be able to see and modify your motion control settings on-the-fly? With SMI you can. The Playground automatically detects connected motors and gathers data in the Motor Info tab. In the SMI Playground you can modify Torque, Velocity, and Position settings in real-time. Using numerical values for input or the interactive interface with drag and drop, sliders, and radio buttons, you can see the results immediately.

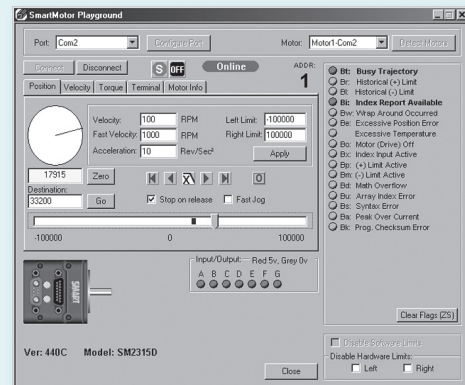



SMNC™, Animatics' G-Code based servo motion control software, uses numeric control to deliver multi-axis contouring for your Animatics SmartMotor™ applications. SMNC provides a set of features that are comparable to any CNC system, including a user interface that is similar in appearance to a traditional CNC system. Review the table in this section to see the G and M Codes that are supported by SMNC software.

SMNC Communicates with SmartMotors via RS-232, RS-485, and CANopen.

SMNC fully supports Class 5 SmartMotors. SMNC now takes advantage of higher bandwidth RS232 Contouring Mode at up to 115.3 Kbaud and even fast CANopen CIA 402 IP (Optional Interpolation Protocol) for up to 1Mb data transfer rates with PVT (Position-Velocity-Time) data packet rates down to 400 microseconds per axis.

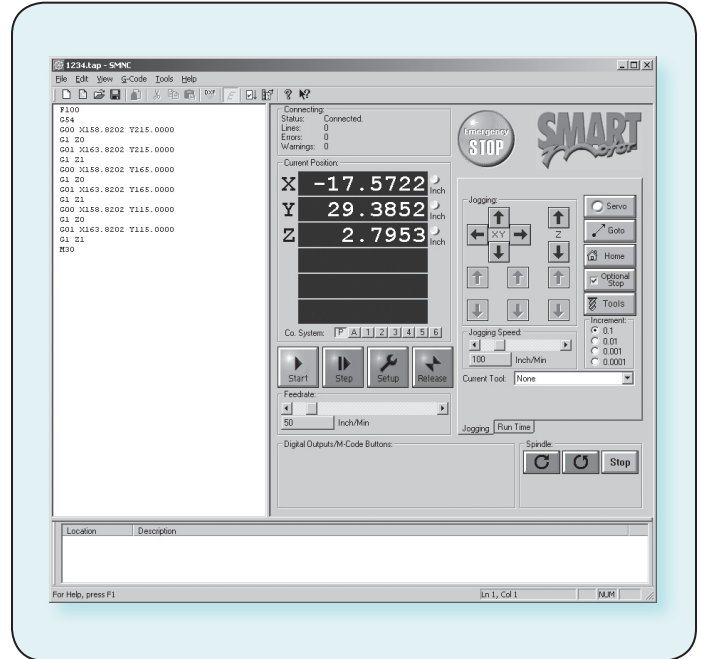

SMNC standard features include:

- Linear and circular motion control of multiple axes
- Configures SmartMotors across multiple serial ports
- Converts CAD-DXF files into motion control G and M Codes
- Duplication of axis motion for gantry systems
- Smooth control of acceleration and deceleration for sensitive curvilinear motion
- Large numerical display
- 6 axis control, includes axis Mimic and Spindle
- User-definable M-Codes for digital output
- Displays source code during execution
- Writes and edits any G-Code program in the source view, with added support for:
 - 3D linear movements
 - CW and CCW Circular movements
 - CW and CCW Helical Movements
 - Wait, Pause, definable M-Codes, Spindle Commands and more
- Defines up to 40 M-Code commands and views their status during execution
- Imports graphic files with DXF format and converts them to G-Code programs
- Exports G-Code programs to Coordinated Motion Files
- Checks and runs a G-Code program or Coordinated Motion file
- Checks features during G-Code program execution:
 - Feed Hold
 - Single step
 - Reset (End)
 - Emergency stop
- Jogs the device using the Jog Buttons, and moves it to any location using the Go To utility on the Panel view
- Controls the Spindle using related buttons on the Panel View. The Spindle can be a SmartMotor or any other type of motor controlled by M-Codes and digital outputs
- Sets any connected SmartMotor in Coordinated Motion Mode, Spindle Mode, Mimic Mode, Rotary/Vector Mode, or Uncoordinated Mode

SMNC™ provides full user control over standard motion parameters and table (work area) dimensions. Additional control includes the ability to custom tailor how motion responds through tight corners and small arcs and circles allowing for smooth transition through the entire path.

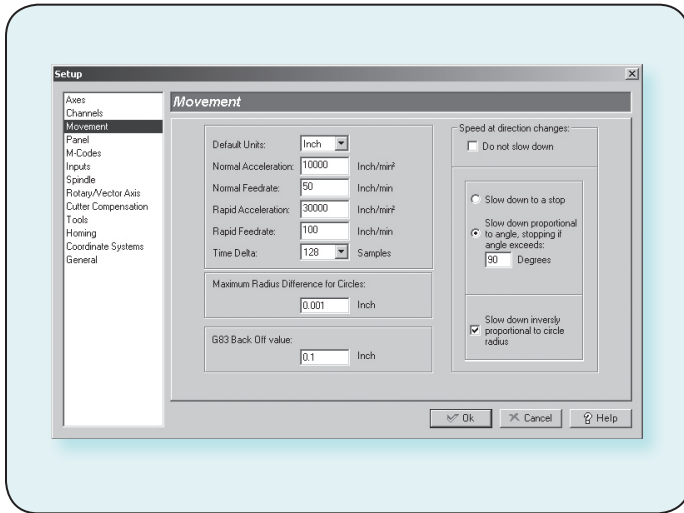

Cutter compensation has options to either ignore holes, skip holes or enter holes as shown below. Additional parameters allow for automatic Z axis control through the holes and the ability to warn the end user when regions are adversely affected.

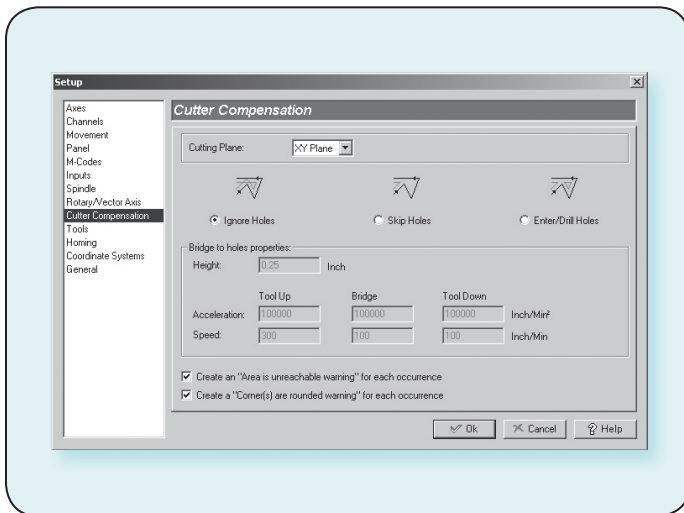

New features:

- Define up to 30 Inputs to perform SMNC functions, such as Start, Reset, and Feed Hold, or as interlocks.
- Define up to 10 different tools. The current tool can be changed in a G-Code program.
- Password protection to control user access for many features.
- Define up to 7 different coordinate systems (G56-G59, G154)
- Customizable homing methods.

G and M codes supported by SMNC

Codes	Description
G0	Rapid Linear movement
G1	Normal Linear movement
G2	Clockwise circular movement
G3	Counterclockwise circular movement
G4	Wait
G17	Select the X-Y plane for circular movements
G18	Select the X-Z plane for circular movements
G19	Select the Y-Z plane for circular movements
G20	Change units to inch
G21	Change units to millimeter
G28	Return to the 1st Reference point
G30	Return to the 2nd Reference point
G40	Cancel cutter compensation
G41	Start cutter compensation left
G42	Start cutter compensation right
G43	Start tool length compensation
G49	Cancel tool length compensation
G54	Use preset coordinate system 1
G55	Use preset coordinate system 2
G56	Use preset coordinate system 3
G57	Use preset coordinate system 4
G58	Use preset coordinate system 5
G59	Use preset coordinate system 6
G80	Cancel Modal Motion (Used with canned cycles)
G81	Canned cycle: drilling
G82	Canned cycle: drilling with dwell
G83	Canned cycle: peck drilling
G85	Canned cycle: boring, no dwell, feed out
G89	Canned cycle: boring dwell feed out
G90	Change coordinate system to absolute
G91	Change coordinate system to incremental
G92	Change the logical origin
G98	Initial level return mode in Canned cycle
G99	Retract-point level return mode in Canned cycle
G101	Move the rotary axis
G154	Use preset coordinate system 7
D	Change the tool index for cutter compensation (G40, G41, G42)
F	Change the Feed rate (Normal Speed)
H	Change the tool index for tool length compensation (G43, G49)
S	Change the Spindle Speed
T	Current tool index (M6)
M0	Pause
M1	Optional Stop
M2	End of program
M3	Turn on Spindle Clockwise
M4	Turn on Spindle Counterclockwise
M5	Turn off Spindle
M6	Change current Tool
M8	Turn on the Coolant
M9	Turn off the Coolant
M30	End of program and force turning off all of digital outputs
M99	End the program and restart it

SMIEngine

Free Download from www.animatics.com

Animatics' SMIEngine™ is a source code module library created as a software tool for the Windows Operating System environment. It comes free with the installation of the SMI software.

The installation includes source code examples written in: Borland C++, Microsoft C++, Visual C, VB and VBA (Excel).

SMIEngine is based on the Windows Component Object Model (COM) and works with:

- Microsoft C++
- Borland C++
- Microsoft Visual Basic (VB)
- VBA (Visual Basic for Applications)
- MS.Net environment
- Borland Delphi
- Pascal
- Python
- LabView (when installed as an Active-X component)

Note about Windows Vista: With the release of Microsoft Vista, the name of the dll file changes from SMEEngine.dll to IntegMotorInterface.dll. Other than the name change, all internal definitions have remained the same and are fully backwards compatible to existing applications with no need to change the body of the source code.

Using SMIEngine, you can perform the following tasks:

- Configure PC serial ports
- Address Animatics SmartMotors™ through selected serial ports
- Send commands to the motors and receive motor responses that allow you to:
 - Control and change modes of operation
 - Update or change motion parameters and variables
 - Gather real-time data from motors for online diagnostics
 - Control the motors using Coordinated Motion (Contouring or Host Mode)
 - Create circular and linear path coordinates used for Coordinated Motion
- Work with downloadable SmartMotor code to:
 - Scan user program source files (.sms) for errors
 - Create an executable SmartMotor compiled user program file (.smx)
 - Download and upload compiled user programs to and from motors
 - Create a list of errors in a user program and provide an interface for navigating through errors

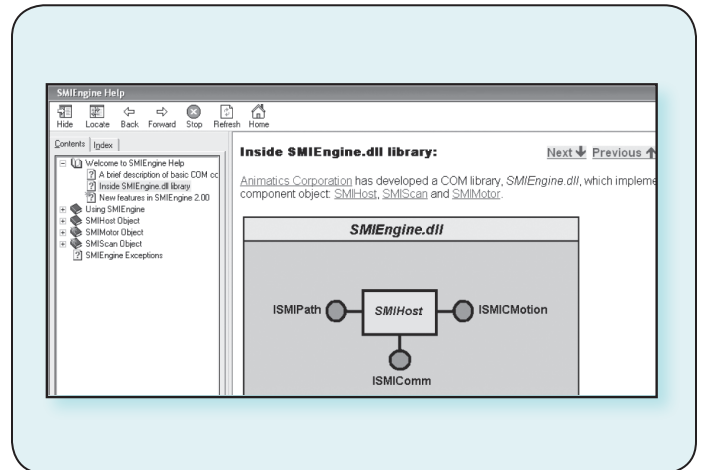

Optimizing the SMIEngine for Multi-Axis coordinated Motion Control:

Multiple Instances of the SMIEngine can be run at the same time for each communications port that is open. In doing so, the application can maximize usage of communications bandwidth to each SmartMotor or each set of motors. Highly effective and efficient applications can be created to control CNC machines via a PC.

Appendix Contents

Application Sizing Equations pg. 204 & 205

Calculating actual load imposed on the servo is imperative to proper motor sizing. Calculating total Power aids in sizing of power supplies.

Motor sizing equations are provided to aid in system design.

Common equations for calculating load torque include belt drive, Bal Screw and Rack & Pinion mechanical systems.

Motion Glossary pg. 206-208

If you have read a term in the catalog that you are not familiar with, or you need to brush up on your motion control terminology, turn to the motion glossary for definitions of terms used throughout the catalog and on www.animatics.com This glossary of terms is written specifically for Animatics' SmartMotor servos and other products and provides a wealth of information that you would not find searching the term in your average dictionary.

Command Set Overview pg. 210-212

This is your go to reference for all commands that you would need to work a SmartMotor. This section includes communication commands, program flow commands, I/O commands, math commands, motion commands, status commands and variable commands. Some of the commands have a *(Combitronic logo) designation beneath them, meaning the commands with this designation require Combitronic with the CANopen or DeviceNet product configuration option in order to execute the command. These commands will only work with Class 5 SmartMotor servos. You can also find sample SMI programs to download that feature many of the commands at www.animatics.com/support.

Frequently Asked Questions (FAQ) pg. 213-215

The FAQ section is authored based on inquiries to our sales, tech support and part number experts. It is highly suggested that you read through the FAQ section prior to purchasing your SmartMotor and other Animatics products to ensure you have everything you need to correctly run and connect your SmartMotor. Many common issues regarding troubleshooting can be easily solved by reading through the FAQ and warning section before contacting Animatics technical support.

Controls, Warnings and Cautions pg. 216 & 217

Please read the controls, warnings and cautions sections carefully. Much of the information in this section will save you the time and money of contacting Animatics for an RMA in the future. It is highly suggested that you read this section before purchasing your SmartMotor and other Animatics products to ensure you have everything you need to correctly run and connect your

SmartMotor. Topics range from mechanical brakes and power supplies to SmartMotor hardware and control limitations. You can also find valuable information to aid in troubleshooting on the Forum at www.animatics.com/support.

Animatics Conformity Statement pg. 218

Animatics Warranty Statement pg. 219

Animatics SmartMotor Success Checklist pg. 220

The SmartMotor Success Checklist on page 220 is an easy, step-by-step guide to assure success in using the Animatics SmartMotor to maximize your system's reliability. You can check your system design and implementation against our checklist and then keep the page handy to document your settings. If needed, you may also send it along with any motors that are being returned to Animatics for inspection or repair.



Application Sizing Equations

OVERVIEW
MOTOR SPECIFICATIONS
LINEAR SYSTEMS
CONNECTIVITY
PERIPHERALS
CONNECTIVITY
IP 65 MODELS & CONNECTIVITY
POWER SUPPLIES & SHUNTS
GEAR HEADS
SOFTWARE
APPENDIX

Calculating Power: the Real Story

Unit of electrical power where : Watts =(volts)(amps) or $W=V \cdot A$
Watts are a unit consisting of time since amps are a measure of electron flow per unit time.

For this reason, Torque cannot be directly equated with Watts or Horsepower without consideration of RPM where revolutions per minute contains time that would cancel out the time in watts to give you torque. This is why Horsepower is a useless unit of measure when sizing SmartMotor for motion control applications!

One horsepower equals 746 watts and has nothing to do with torque by itself!!!!

Formula for Power to Torque:

$$\text{Power (HP)} = \text{Power (Watts)} \times 746$$

$$\text{Power (Watts)} = \frac{N(\text{RPM}) \times T(\text{ft-lbs})}{7.04}$$

$$\text{Power (HP)} = \frac{N(\text{RPM}) \times T(\text{ft-lbs})}{5252}$$

Torque required will be: _____

$$T(\text{ft-lbs}) = \frac{\text{Power (Watts)} \times 7.04}{N(\text{RPM})}$$

$$T(\text{ft-lbs}) = \frac{\text{Power (HP)} \times 5252}{N(\text{RPM})}$$

All references on the right side of this page are used in the formulas on page 205.

Typical Friction Coefficients ($F_{fr} = \mu W_L \cos \gamma$)

Materials	μ	Mechanism	μ
Steel on Steel	~0.58	Ball Bushings	<0.01
Stl. on Stl. (greased)	~0.15	Linear Bearings	<0.01
Aluminum on Steel	~0.45	Dove-Tail Slides	~0.2++
Copper on Steel	~0.30	Gibb Ways	~0.5++
Brass on Steel	~0.35		
Plastic on Steel	~0.15-0.25		

Symbol	Definition	SI	English
C_G	Circumference of Gear	m (or cm)	in (or ft)
$C_{P:1,2,3}$	Circumference of Pulleys, 1, 2, or 3	"	"
D_G	...(pitch dia.) of Gear	"	"
D_{PM}	...(pitch dia.) of Pulleys on Motor	"	"
$D_{P:1,2,3}$...(pitch dia.) of Pulleys 1, 2, or 3	"	"
e	efficiency of mechanism or reducer	%	%
F	Forces due to	N	lb
F_{Fr}	...friction ($F_{fr} = mWL \cos g$)	"	"
F_g	...gravity ($F_g = WL \sin g$)	"	"
F_p	...Push or Pull forces	"	"
g	gravity accel constant	9.80 m/s ²	386 in/s ²
J	mass moment of inertia for	kg-m ²	lb-in ²
J_C	...Coupling	g-cm ²	oz-in ²
J_G	...Gear	etc.	or
J_L	...Load " in-lb-s ²		
$J_{L \rightarrow M}$...Load reflected to Motor	"	or
J_M	...Motor	"	in-oz-s ²
$J_{P:1,2,3}$...Pulley or sprocket 1, 2, or 3	"	"
J_{Total}	...Total of all inertias	"	"
J_S	...lead Screw	"	"
N_r	Number ratio of reducer	none	none
P_G	Pitch of Gear, sprocket or pulley	teeth/m	teeth/inch
P_S	Pitch of lead Screw	revs/m	revs/inch
T	Torque...(for "required" Calculations)	Nm	in-lb
T_L	...at Load (not yet reflected to motor)	"	"
T_P	...due to Preload on screw nut, etc.	"	"
V_L	linear Velocity of Load	m/s	in/s
ω_M	angular/rotational velocity of Motor	rad/s	rps or rpm
W_L	Weight of Load	kg	lb
W_B	Weight of Belt (or chain or cable)	"	"
W_T	Weight of Table (or rack & moving parts)	"	"
θ	rotation...	revs	revs
$\theta_{a,c,or d}$	rotation during accel, decel, etc.	"	"
θ_L	rotation of Load	"	"
θ_M	rotation of Motor	"	"
μ	coefficient of friction	none	none
γ	load angle from horizontal	degrees	degrees

Application Sizing Equations

Motion Mechanism and Motion Equations

Gearing

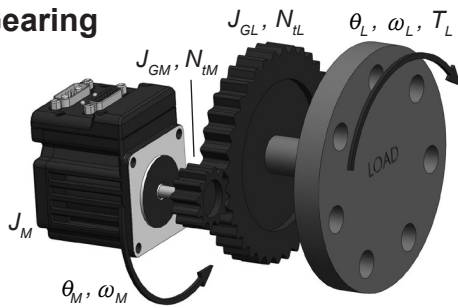

$$N_r = \frac{N_{GL}}{N_{GM}}$$

$$\theta_M = N_r \times \theta_L$$

$$\omega = N_r \times \omega_L$$

Inertia, Torque Equations

$$J_{Total} = J_M + J_{GM} + J_{GL-M} + J_{L-M}$$

$$J_{GL-M} = \left(\frac{1}{N_r}\right)^2 \times \frac{J_{GL}}{e} \quad J_{L-M} = \left(\frac{1}{N_r}\right)^2 \times \frac{J_L}{e}$$

$$T_{L-M} = \frac{T_L}{N_r \times e}$$

Rack & Pinion

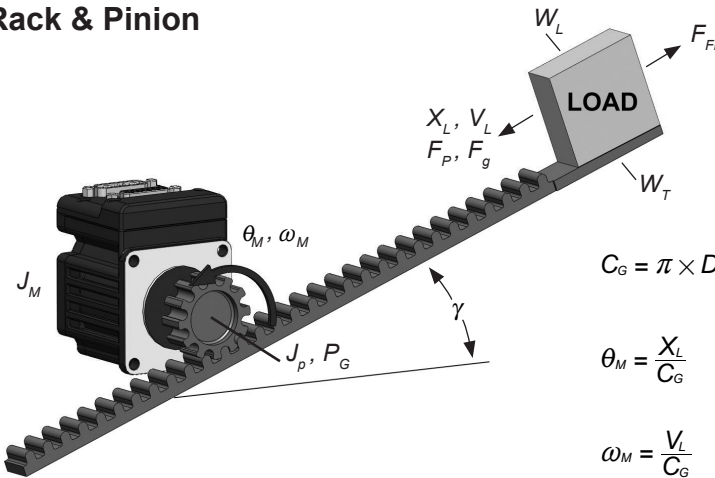

$$C_G = \pi \times D_G = \frac{N_i}{P_G}$$

$$\theta_M = \frac{X_L}{C_G}$$

$$\omega_M = \frac{V_L}{C_G}$$

$$J_{Total} = J_M + J_G + J_{L-M}$$

$$J_{L-M} = \frac{(W_L + W_T)}{g \times e} \times \left(\frac{D_G}{2}\right)^2$$

$$F_g = (W_L + W_T) \times \sin \gamma$$

$$F_{fr} = \mu \times (W_L + W_T) \times \cos \gamma$$

$$T_{L-M} = \left(\frac{F_p = F_g + F_{fr}}{e}\right) \times \left(\frac{D_G}{2}\right)$$

Belt Drive

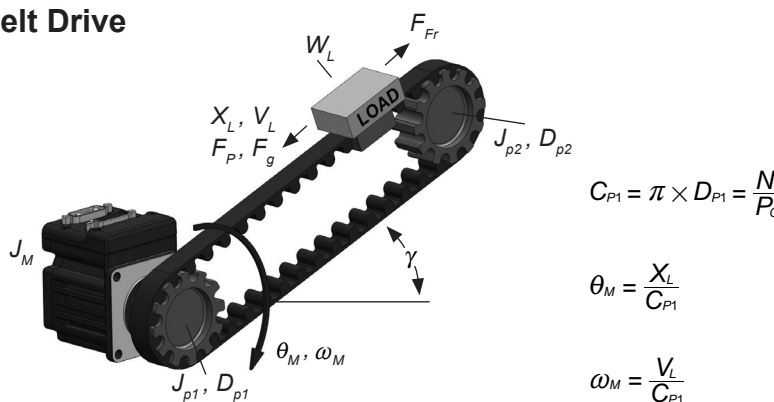

$$C_{P1} = \pi \times D_{P1} = \frac{N_i}{P_G}$$

$$\theta_M = \frac{X_L}{C_{P1}}$$

$$\omega_M = \frac{V_L}{C_{P1}}$$

$$J_{Total} = J_M + J_{P1} + \left(\frac{D_{P1}}{D_{P2}}\right)^2 J_{P2} + J_{Load}$$

$$J_{L-M} = \frac{(W_L + W_B)}{g \times e} \times \left(\frac{D_{P1}}{2}\right)^2$$

$$F_g = (W_L + W_B) \times \sin \gamma \quad F_{fr} = \mu \times (W_L + W_T) \times \cos \gamma$$

$$T_{L-M} = \left(\frac{F_p + F_g + F_{fr}}{e}\right) \times \left(\frac{D_{P1}}{2}\right)$$

Leadscrew

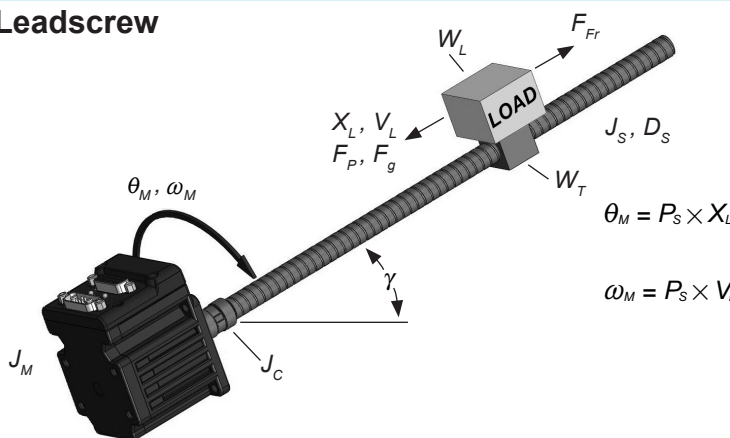

$$\theta_M = P_s \times X_L$$

$$\omega_M = P_s \times V_L$$

$$J_{Total} = J_M + J_C + J_S + J_{L-M}$$

$$J_{L-M} = \frac{(W_L + W_T)}{g \times e} \times \left(\frac{1}{2\pi \times P_s}\right)^2$$

$$F_g = (W_L + W_T) \times \sin \gamma \quad F_{fr} = \mu \times (W_L + W_T) \times \cos \gamma$$

$$T_{L-M} = \left(\frac{F_p + F_g + F_{fr}}{2\pi \times P_s \times e}\right) + T_P$$

Acceleration

A change in velocity as a function of time. Acceleration usually refers to increasing velocity, and deceleration to decreasing velocity.

Accuracy

A measure of the difference between expected position and actual position of a motor or mechanical system. Motor accuracy is usually specified as an angle representing the maximum deviation from expected position.

Ambient Temperature

The temperature of the cooling medium, usually air, immediately surrounding the motor or another device.

Angular Accuracy

The measure of shaft positioning accuracy on a servo or stepping motor.

Back EMF

The voltage generated when a permanent magnet motor is rotated. This voltage is proportional to motor speed and is present regardless of whether the motor winding(s) are energized or de-energized.

Breakaway Torque

The torque required to start a machine in motion. Almost always greater than the running torque.

Brushless Motor

Class of motors that operate using electronic commutation of phase currents, rather than electromechanical (brush-type) commutation. Brushless motors typically have a permanent magnet rotor and a wound stator.

Closed Loop

A broadly applied term, relating to any system in which the output is measured and compared to the input. The output is then adjusted to reach the desired condition. In motion control, the term typically describes a system utilizing a velocity and/or position transducer to generate correction signals in relation to desired parameters.

Cogging (Cogging Torque)

A term used to describe non-uniform angular velocity. Cogging appears as a jerkiness, especially at low speeds.

Commutation

A term which refers to the action of steering currents or voltages to the proper motor phases so as to produce optimum motor torque. Proper commutation means the relationship of the Rotor to the Stator must be known at all times.

1. In brush type motors, commutation is done electromechanically via the brushes and commutator.
2. In brushless motors, commutation is done by the switching electronics using rotor position information obtained by Hall sensors, single turn absolute encoder, or a resolver.

Controller

A term describing a functional block containing an amplifier, power supplies, and possibly position-control electronics for operating a servomotor or step motor.

Current at Peak Torque (IPK) (Amperes)

The amount of input current required to develop "peak torque". This is often outside the linear torque/current relationship.

Current, Rated

The maximum allowable continuous current a motor can handle without exceeding motor temperature limits.

Detent Torque

The maximum torque that can be applied to an un-energized step motor without causing continuous rotating motion.

Duty Cycle

For a repetitive cycle, the ratio of on time to total cycle time. Duty cycle (%) = $[\text{On time} / (\text{On time} + \text{Off time})] \times 100\%$

Dynamic Braking

A passive technique for stopping a permanent magnet brush or brushless motor. The motor windings are shorted together through a resistor which results in motor braking with an exponential decrease in speed.

Efficiency

The ratio of power output to power input.

Electrical Time Constant (te) (Seconds)

The time required for current to reach 63.2% of its final value for a fixed voltage level. Can be calculated from the relationship $t_e = L/R$ where L is inductance (henries) and R is resistance (ohms).

Encoder

A feedback device which converts mechanical motion into electronic signals. The most commonly used, rotary encoders, output digital pulses corresponding to incremental angular motion. For example, a 1000-line encoder produces 1000 pulses every mechanical revolution. The encoder consists of a glass or metal wheel with alternating transparent and opaque stripes, detected by optical sensors to produce the digital outputs.

Feedback

A signal which is transferred from the output back to the input for use in a closed loop system.

Form Factor

The ratio of RMS current to average current. This number is a measure of the current ripple in a SCR or other switch-mode type of drive. Since motor heating is a function of RMS current while motor torque is a function of average current, a form factor greater than 1.00 means some fraction of motor current is producing heat but not torque.

Four Quadrant

Refers to a motion system which can operate in all four quadrants; i.e., velocity in either direction and torque in either direction. This means that the motor can accelerate, run, and decelerate in either direction.

Friction

A resistance to motion caused by contact with a surface. Friction can be constant with varying speed (Coulomb friction) or proportional to speed (viscous friction).

Hall Sensor

A feedback device which is used in a brushless servo system to provide information for the amplifier to electronically commutate the motor. The device uses a magnetized wheel and hall effect sensors to generate the commutation signals.

Holding Torque

Sometimes called static torque, holding torque specifies the maximum external torque that can be applied to a stopped, energized motor without causing the rotor to rotate. Generally used as a figure of merit when comparing motors.

Horsepower

A Unit of measure of Power. One horsepower is equal to 746 watts. The measurement of Rotatry power must take speed and torque into account. Horsepower is a measure of a motor's torque and speed capability.

Formula: $HP = \text{Torque (lb-in.)} \times \text{Speed (RPM)} / 63,025$
 $HP = \text{Torque (lb-ft.)} \times \text{Speed (RPM)} / 5,252$
 $HP = \text{Volts} \times \text{Amps} \times \text{Efficiency} / 746$

Inductance (L) (mH - millihenries line-to-line)

The electrical equivalent to mechanical inertia; that is, the property of a circuit, which has a tendency to resist current flow when no current is flowing, and when current is flowing has a tendency to maintain that current flow.

Inductance (mutual)

Mutual inductance is the property that exists between two current carrying conductors or coils when magnetic lines of force from one link with those of the other.

Inertia

The property of an object to resist change in velocity unless acted upon by an outside force. Higher inertia objects require larger torques to accelerate and decelerate. Inertia is dependent upon the mass and shape of the object.

Inertial Match

For most efficient operation, the system coupling ratio should be selected so that the reflected inertia of the load is equal to the rotor inertia of the motor.

Open-loop

A system in which there is no feedback. Motor motion is expected to faithfully follow the input command. Stepping motor systems are an example of open-loop control.

Overload Capacity

The ability of a drive to withstand currents above its continuous rating. It is defined by NEMA as 150% of the rated full-load current for "standard industrial DC motors" for one minute.

Peak torque (Tpk) (lb-in.)

The maximum torque a brushless motor can deliver for short periods of time. Operating permanent magnet motors above the maximum torque value can cause demagnetization of the rare-earth magnets. This is an irreversible effect that will alter the motor characteristics and degrade performance. This is also known as peak current. Not to be confused with system peak torque, which is often determined by amplifier peak current limitations, where peak current is typically two times continuous current.

Poles

Refers to the number of magnetic poles arranged on the rotor of the brushless motor. Unlike an AC motor, the number of poles has no direct relationship to the base speed of the motor.

Power

The rate at which work is done. In motion control, power is equal to torque multiplied by speed.
Power (watts) = force x distance/time. Power= voltage x current

Power Factor

Ratio of true power (kW) to apparent power (kVA).

Pulse Rate

The frequency of the step pulses applied to a step motor driver. The pulse rate, multiplied by the resolution of the motor/driver combination (in steps per revolution), yields the rotational speed in revolutions per second.

Pulse Width Modulation (PWM)

Pulse width modulation (PWM), describes a switch-mode (as opposed to linear) control technique used in amplifiers and drivers to control motor voltage and current.

Regeneration

The action during motor braking, in which the motor acts as a generator and takes kinetic energy from the load, converts it to electrical energy, and returns it to the amplifier.

Repeatability

The degree to which a parameter such as position or velocity can be duplicated.

Resolution

The smallest increment into which a parameter can be broken down. For example, a 1000 line encoder has a resolution of 1/1000 of a revolution.

Resonance

Oscillatory behavior caused by mechanical or electromechanical harmonics and limitations.

Ringing

Oscillation of a system following a sudden change in state.

RMS Current - Root Mean Square Current

In an intermittent duty cycle application, the RMS current is equal to the value of steady state current which would produce the equivalent motor heating over a period of time.

RMS Torque - Root Mean Square Torque

In an intermittent duty cycle application, the RMS torque is equal to the value of steady state torque which would produce the equivalent motor heating over a period of time.

Rotor

The moving part of the motor, consisting of the shaft and magnets. These magnets are analogous to the field winding of a brush-type DC motor.

Settling Time

The time required for a parameter to stop oscillating or ringing and reach its final value.

Speed

Describes the linear or rotational velocity of a motor or other object in motion.

Stall Torque

The amount of torque developed with voltage applied and shaft locked, or not rotating. Also known as locked-rotor torque.

Stator

The non-moving part of the motor. Specifically, it is the iron core with the wire winding in it that is pressed into the frame shell. The winding pattern determines the voltage constant of the motor.

Stiffness

The ability to resist movement induced by an applied torque. Stiffness is often specified as a torque displacement curve, indicating the amount a motor shaft will rotate upon application of a known external force when stopped.

Torque

A measure of angular force which produces rotational motion. This force is defined by a linear force multiplied by a radius; e.g. lb-in. Formula: Torque (lb-ft.) = 5,250 x HP/RPM

Torque Constant (KT = lb-ft./A)

An expression of the relationship between input current and output torque. For each ampere of current, a fixed amount of torque is produced.

NOTE: Torque constants ARE NOT linear over the operating range of a motor. They apply best at ~75% of no load maximum speed or where the peak and continuous torque curves meet.

Torque-to-Inertia Ratio

Defined as the motor's holding torque divided by the inertia of its rotor. The higher the ratio, the higher a motor's maximum acceleration capability will be.

Velocity

The change in position as a function of time. Velocity has both a magnitude and sign.

Voltage Constant (KE) (V/kRPM peak, line-to-line)

May also be termed Back-EMF constant. When a motor is operated, it generates a voltage proportional to speed, but opposing the applied voltage. The shape of the voltage waveform depends upon the specific motor design. For example, in a brushless motor, the wave shape may be trapezoidal or sinusoidal in nature.

Reference Key:

- # - is the IO Bit Number
- m - is the mask value of which bits are affected
- W - defines it as a word (16 bits)
- expression - an expression must contain no more than a total maximum of 32 operators, values, and parenthesis.
- value - a number, variable or math expression with one operand
- constant - means a fixed integer
- gen# Trajectory generator number: 1 or 2
- i - Interrupt number , valid values are from 0 to 7

Communication Commands:

- ADDR=expression** Set motor's serial communications address. Applies for both RS232 and RS485
- BAUD(x)=y** This allows for COM0 or COM1 to be changed, x is the channel (0 or 1) and y is baud rate
- CADDR=expression** Set CAN address, can be different from serial address, default is 63
- CBAUD=expression** Set CAN baud rate, default is 125000
- CCHN(RS2,0)** Close communication channel command
- ECHO** Must be used to insure all data received in one motor will be echoed to next motor
- ECHO_OFF** Default, turn communication's echo off
- GETCHR** Get the next character from channel 0
- GETCHR1** Get the next character from channel 1
- LEN** Number of characters in channel 0 buffer
- LEN1** Number of characters in channel 1 buffer
- RCADDR** Reports CAN address
- RCBAUD** Reports CAN baud rate
- RCHN(0)** Report channel 0 error bits
- RCHN(1)** Report channel 1 error bits
- SILENT** Ignore print commands to channel 0 from user program
- SILENT1** Ignore print commands to channel 1 from user program
- SLEEP** Ignore commands for channel 0 except the WAKE command
- SLEEP1** Ignore commands for channel 1 except the WAKE command
- STDOUT=0** Sets internal report commands to RS232 (default)
- STDOUT=1** Sets internal report commands to RS485
- TALK** Enable prints for channel 0 from user program
- TALK1** Enable prints for channel 1 from user program
- WAKE** Wake for channel 0
- WAKE1** Wake for channel 1

Program Flow Commands:

- CASE expression** Switch case statement
- C constant** Subroutine label, e.g. C10 for subroutine 10, must have a RETURN for each C label
- DEFAULT** Default action for switch case statement
- DITR(i)** Individual interrupt disable

- EITR(i)** Individual interrupt enable
- ELSEIF expression** Used for IF statements to test another condition, if expression is true, then execute code
- END** End program execution
- ENDIF** End statement for IF code structures
- ENDS** Command for end of switch case statement
- GOSUB(value)** Call a subroutine, value up to 999
- GOTO(value)** Jump program execution to a label, value up to 999
- IF expression** Conditional Test, expression can be multiple math operations
- ITR(i, status_wrd#, bit#, s ,label#)** Interrupt setup
- ITRD** Global interrupt scanner disable
- ITRE** Global interrupt scanner enable
- LOOP** Loop command for while loops
- PAUSE** Pause program execution, used for interrupts
- RESUME** Resume program execution
- RETURN** Return from subroutine
- RETURNI** Return from interrupt
- RUN** Start program execution
- RUN?** Wait at this point for RUN command before program starts to execute
- STACK** Resets all GOSUB stack returns and Interrupts
- SWITCH expression** Switch case statement
- TWAIT** Wait for trajectory to complete, only used in program
- TWAIT(gen#)** Wait for trajectory generator (gen#) to complete it's move
- TSWAIT** Wait for synchronized trajectory to complete, down loaded program only * **COMBITRONIC™**
- WAIT=expression** Set wait time in milliseconds
- WHILE expression**
- LOOP** While loop format

I/O Commands:

- EIGN(#)** Assign a single I/O point as general use input
- EIGN(W,0)** Assign all local I/O as general use inputs
- EIGN(W,0,12)** Assign inputs 2 and 3 as general use inputs at once (disabling over-travel limits)
- EIGN(W,0,m)** Assign a masked word-sized set of local I/O as general use inputs at once
- EILN** Set port C (I/O-2) as negative over travel limit
- EILP** Set port D (I/O-3) as positive over travel limit
- EIRE** Set I/O 6 to capture external encoder's current value
- EIRI** Set I/O 6 to capture internal encoder's current value
- EISM(6)** Issue (G) when local input 6 goes low
- EOBK(#)** Configure a given output to control an external brake
- IN(#)** x=IN(#), assign the state of a specific I/O to a variable (x in this case)
- IN(W,0)** x=IN(W,0), assign the state of the first word of local I/O to the variable x
- INA(A,#)** x=INA(A,#), raw analog reading: 10 bit resolution spanned over signed 16 bit range

* **COMBITRONIC™** These commands require Combitronic with -C or -DN product configuration option to execute.



Command Set Overview

OVERVIEW
MOTOR SPECIFICATIONS
LINEAR SYSTEMS
CONNECTIVITY
PERIPHERALS
IP 65 MODELS & CONNECTIVITY
POWER SUPPLIES & SHUNTS
GEAR HEADS
SOFTWARE
APPENDIX

INA(V,#)	x=INA(V,#), input voltage in millivolts of analog input value for a given I/O defined by #
INA(V1,#)	x=INA(V1,#), scaled 0-5 VDC reading in millivolts directly, 3456 would be 3.456 VDC
OC(#)	x=OC(#), individual output status, bit 1 if output is being driven
OC(W,#)	x=OC(W,#), block output status, bit 1 if output is being driven
OF(#)	x=OF(#), returns present fault state for I/O defined by #
OF(L,#)	x=OF(W,#), returns bit mask fault latched for I/O points
OF(W,#)	x=OF(W,#), returns bit mask of present faulted I/O points
OR(value)	Reset output (turn off)
OS(value)	Set output (turn on)
OUT(#)=expression	if expression LSB = 1, then it's true(1), otherwise it's false (0)

Math Commands:

-	Subtract
!	Bitwise exclusive OR
!=	Not equal to
%	Modulo (remainder) division
&	Bitwise AND
*	Multiply
/	Divide
^	Power limited to 4th power and below, integers only
	Bitwise inclusive OR
+	Add
<	Less than
<=	Less than or equal to
==	Equal to
>	Greater than
>=	Greater than or equal to
ABS(value)	Absolute Value
ACOS(value)	Arc Cosine
ASIN(value)	Arc Sine
ATAN(value)	Arc Tangent
COS(value)	Cosine
FABS(value)	Floating point absolute value
FSQRT(value)	Floating point square root
RANDOM=expression	Set the random seed value 0 to 2 ³¹ - 1
RRANDOM	Report the next available random number in the range 0 to 2 ³¹ - 1
SIN(value)	Sine
SQRT(value)	Square Root
TAN(value)	Tangent
TMR(x,t)	Sets timer x for t milliseconds

Motion Commands:

ADT=expression	Set the accel/decel at once for a move
-----------------------	--

ADTS=expression	Set sync accel/decel at once for a move * COMBITRONIC™
Ai(0)	Arm index rising edge of internal encoder
Ai(1)	Arm index rising edge of external encoder
Aij(0)	Arm index rising edge then falling edge internal encoder
Aij(1)	Arm index rising edge then falling edge external encoder
Aj(0)	Arm index falling edge of internal encoder
Aj(1)	Arm index falling edge of external encoder
Aji(0)	Arm index falling edge then rising edge internal encoder
Aji(1)	Arm index falling edge then rising edge external encoder
AMPS=expression	Current limit value. 0-1023
AT=expression	Set the acceleration target for a move
ATS=expression	Set sync acceleration target for a move * COMBITRONIC™
BREAK	Break out of while loop
BRKENG	Manually Engage the brake
BRKRLS	Manually Release the brake
BRKSRV	Brake Servo, engage the brake when the drive is not active (default)
BRKTRJ	Brake Trajectory
CTR(0)	Present value of internal encoder
CTR(1)	Present value of external encoder
DEL=expression	Set maximum allowable derivative error limit
DT=expression	Set the deceleration target for a move
DTS=expression	Set sync deceleration for a move * COMBITRONIC™
EL=expression	Set maximum allowable following error limit
ENC1	Enable external encoder for servo
ENC0	Enable internal encoder for servo
F	Set tuning values
G	Go, initiates all buffered modes of operation
G(gen#)	Go, initiate motion in trajectory generator (gen#)
GS	Go synchronized, initiates linear interpolated moves * COMBITRONIC™
KA=expression	Feed forward gain
KD=expression	Derivative gain coefficient
KG=expression	Gravity offset
KI=expression	PID integral gain
KL=expression	PID integral limit
KP=expression	PID proportional gain
KS=expression	Differential sample rate
KV=expression	Velocity feed forward gain
MC	Initiate electronic camming
MC(2)	Set Trajectory Generator 2 to run in electronic camming
MDB	Enable TOB when in one of the 2 trapezoidal modes
MDE	Set motor to enhanced trapezoidal mode commutation by using encoder
MDS	Set motor to sine mode commutation

* **COMBITRONIC™** These commands require Combitronic with -C or -DN product configuration option to execute.



Command Set Overview

MDT	Set motor to trapezoidal mode commutation using hall sensors (default mode)	SLN=expression	Set the negative software travel limit
MFA(value)	Accel over <i>value</i> master distance. Default is zero (off)	SLP=expression	Set the positive software travel limit
MFD(value)	Decel over <i>value</i> master distance. Default is zero (off)	T=expression	Set the commanded torque while in MT mode
MFDIV=expression	Assign Incoming counts Divisor	TH=expression	Set maximum allowable thermal limit (degrees C)
MFMUL=expression	Assign Incoming counts Multiplier	VT=expression	Set the velocity target for a move
MFO	Initiate and zero counter, but do not follow	VTS=expression	Set synchronized velocity target for a move * COMBITRONIC™
MFR	Select follow mode using quadrature encoder input.	X	Decelerate to a stop at present deceleration rate
MFR(2)	Set Trajectory Generator 2 to run in Mode Follow Ratio (electronic Gearing)	X(gen#)	Decelerate to a stop , trajectory generate (gen#)
MFSLEW(value)	Stay at slew for <i>value</i> distance, then decel	<hr/>	
MINV(0)	Default motor commutation direction	Status Commands:	
MINV(1)	Invert commutation, shaft rotates opposite direction	Ba	<i>Over current bit, status word 0, bit 4 status word 1, bit 3</i>
MP	Initiate Position Mode	Be	<i>Excessive position error, status word 0, bit 6</i>
MP(1)	Set Trajectory Generator 1 to run in Position Mode	Bh	<i>Excessive temperature occurred, status word 0, bit 5</i>
MS0	Initiate and zero counter, but do not follow	Bi(0)	<i>Rising Edge Capture on Encoder 0 (internal), status word 1, bit 2</i>
MSR	Calculate Mode Step Ratio and prepare to follow	Bi(1)	<i>Rising Edge Capture on Encoder 1 (external), status word 1, bit 6</i>
MT	Initiate Torque Mode (Open Loop)	Bj(0)	<i>Falling Edge Capture on Encoder 0 (internal), status word 1, bit 7</i>
MTB	Enable mode torque brake	Bj(1)	<i>Falling Edge Capture on Encoder 1 (external), status word 1, bit 7</i>
MV	Initiate Velocity Mode	Bk	<i>Main program checksum error, program is corrupt and cannot run, status word 2, bit 15</i>
MV(1)	Set Trajectory Generator 1 to run in Velocity Mode	Bl	<i>Left (-) over travel limit, status word 0, bit 13</i>
O=expression	Set origin, set present position to some value	Bls	<i>Left (-) over travel software limit occurred, status word 1, bit 13</i>
O(gen#)=expression	Set origin for move gen# to some value	Bm	<i>Left (-) over travel limit active, status word 0, bit 15</i>
OFF	Turn the amplifier off	Bms	<i>Left (-) over travel software limit active, status word 1, bit 15</i>
OSH=expression	Origin shift of position counter on the fly	Bo	<i>Motor is off, status word 0, bit 1</i>
OSH(gen#)=expression	Shift origin for move gen# by some value	Bp	<i>Right (+) over travel limit active, status word 0, bit 14</i>
PID1	Set default PID update rate	Bps	<i>Right (+) over travel software limit active, status word 1, bit 14</i>
PID2	Set default PID/2 update rate	Br	<i>Right (+) over travel limit, status word 0, bit 12</i>
PID4	Set default PID/4 update rate	Brs	<i>Right (+) over travel software limit occurred, status word 1, bit 12</i>
PID8	Set default PID/8 update rate	Bs	<i>Command Syntax error note, status word 2, bit 14</i>
PML=expression	Sets the position modulo limit wrap value	Bt	<i>Trajectory in progress, status word 0, bit 2</i>
PMT=expression	Set the position modulo target	Bv	<i>Velocity limit, status word 0, bit 7</i>
PRT=expression	Set the relative target position	Bw	<i>Wrap around occurred, position wrapped through +/- 2^31, status word 3, bit 3</i>
PRTS=(dist1;axis1,dist2;axis2,dist3;axis3)	Set synchronized relative target position * COMBITRONIC™	Bx(0)	<i>Hardware index input probe state for internal encoder, status word 1, bit 8</i>
PRTSS=(dis1;axis)	Set supplemental synchronized relative target position * COMBITRONIC™	Bx(1)	<i>Hardware index input probe state for external encoder, status word 1, bit 9</i>
PT=expression	Set the absolute target position	CLK=expression	<i>System Clock value in milliseconds</i>
PTS=(dist1;axis1,dist2;axis2,dist3;axis3)	Set synchronized absolute target position * COMBITRONIC™	ERRC	<i>Get most recent command error code</i>
PTSS=(dis1;axis)	Set supplemental synchronized absolute target position * COMBITRONIC™	ERRW	<i>Where/Who commanded most recent error</i>
S	Instantly stop motor	FSA ()	<i>FSA(0,0) is default, sets all types of faults to result in MTB</i>
S(gen#)	Instantly stop trajectory generator (gen#)	RAC	<i>Report commanded acceleration</i>
SLD	Disable software travel limits	RAT	<i>Report target acceleration</i>
SLE	Enable software travel limits		
SLM (0)	Make a soft limit only trigger the flag, but not cause a fault		
SLM (1)	Make a soft limit trigger the flag and cause a fault (default mode)		

* **COMBITRONIC™** These commands require Combitronic with -C or -DN product configuration option to execute.



Command Set Overview

OVERVIEW
MOTOR SPECIFICATIONS
LINEAR SYSTEMS
CONNECTIVITY
PERIPHERALS
IP 65 MODELS & CONNECTIVITY
POWER SUPPLIES & SHUNTS
GEAR HEADS
SOFTWARE
APPENDIX

Ra	Report value of variable 'a'
Rab[0]	Report value of ab[0]
Raf[0]	Report floating point value of af[0]
Ral[0]	Report value of al[0]
Raw[0]	Report value of aw[0]
REPTR	Reports EEPROM pointer value
RCKS	Report Checksum
RB_(sw,b)	Report status bit, b, from status word, sw
RCLK	Report system clock in milliseconds
RCTR(0)	Report present value of internal encoder
RCTR(1)	Report present value of external encoder
RDEA	Report actual derivative error
RDEL	Report commanded derivative error limit
RDT	Report target deceleration
REA	Report actual following error
REL	Report commanded following error limit
RI (0)	Report where the rising edge of the internal index was detected
RI (1)	Report where the rising edge of the external index was detected
RIN(#)	Report the state of a I/O
RIN(W,0)	Report the first word of local I/O
RINA(A,#)	Reports analog input value for a given I/O defined by #
RINA(V,#)	Reports voltage level (scaled from supply) of analog input value for a given I/O defined by #
RINA(V1,#)	Reports voltage level (scaled 0-5 VDC) of analog input value for a given I/O defined by #
RJ(0)	Report where the falling edge of the internal index was detected
RJ(1)	Report where the falling edge of the external index was detected
RMFDIV	Report Divisor
RMFMUL	Report Multiplier
RMODE	Report mode of operation
RPA	Report present actual position
RPC	Report present commanded position
RPC(gen#)	Report commanded position for trajectory generator (gen#)
RPMA	Report the current modulo counter
RPML	Report position modulo limit
RPMT	Report the most recent setting of PMT (position modulo target)
RPRA	Report actual relative position
RPRC	Report commanded relative position
RPRT	Report present relative target position
RPT	Report present target position
RRES	Report encoder resolution of motor
RSLN	Report value of negative software limit
RSLP	Report value of positive software limit
RSP	Report sampling rate and firmware version
RSP1	Report firmware revision date
RTH	Report maximum allowable thermal limit

RTMR(x)	Report timer x (present time left in milliseconds)
RT	Report commanded torque
RVC	Report commanded velocity
RVT	Report target velocity
RUIA	Reports current (Amps=UIA/100)
RUJA	Reports bus voltage (Volts=UJA/10)
RVA	Report actual velocity
RW(value)	Report status word
Z_(sw,b)	Clears/zeros status word bits
Za	Reset over current bit
Ze	Reset position error bit
Zh	Reset over temperature bit
Zl	Reset left(-) historical limit bit
Zls	Reset left(-) software historical limit bit
Zr	Reset right(+) historical limit bit
Zrs	Reset right(+) software historical limit bit
Zs	Reset syntax error bit
ZS	Clear all errors, reset system latches to power up state
Zw	Reset wraparound bit

Variable Commands:

a=expression	Variable, 32 bit signed integers, a-z, aa-zz, aaa-zzz, 78 total variables
ab[x]=expression	Array variables, 8 bit byte arrays, x can be 0-203
af[x]=expression	Floating point array variables, x can be 0-7
al[x]=expression	Array variables, 32 bit long arrays, x can be 0-50
aw[x]=expression	Array variables, 16 bit word arrays, x can be 0-101
EPTR=expression	EEPROM pointer, non-volatile memory, use before VLD and VST commands
VLD(variable,quantity)	Load values from EEPROM to variables starting at EPTR location
VST(variable,quantity)	Store values to EEPROM from variables starting at EPTR location

Other Commands:

LOCKP	Disable program (EEPROM) upload
UPLOAD	Upload the program
OCHN(RS2,0,N,9600,1,8,C,1000)	Default: (RS232,chan=0, no parity, 9600 baud,1 stopbit, 8 databits, command,1000 ms timeout)
PRINT("Hello World",#13)	Print command to say "Hello World", see print section for more detailed examples
PRINT1("Hello World",#13)	Print command to say "Hello World" on channel 1, see print section for more detailed example

Note: See users guide for complete list of commands and full syntax.

Many commands such as Cam mode and dual trajectory mode commands are not fully explained here.

Downloading and Uploading Programs

Why will SMI2 not let me download to a SmartMotor™ that is moving or running a program?

Due to safety concerns, the new SMI2 software forces you to turn off the SmartMotor™ holding current or stop a running program prior to download to prevent possible unexpected motion. Let's suppose you have a program that places the SmartMotor™ in Velocity mode or Torque Mode and then you try to download without first tuning off the motor. During travel, it will crash into the end stop while downloading. For safe operation we want to ensure the SmartMotor is in the OFF condition.

When I start a download, the motor stops everything it was doing. Why?

When SMI starts a download of a new program, it issues the END command to stop prior code from running. This is to prevent processor memory pointer errors while the EEPROM header portion is being re-written. It is also for safety reasons.

Is there a way to prevent someone from uploading a program?

Yes. You can protect your program from being seen or copied by sending LOCKP to the motor via serial port. The LOCKP command is a means of locking the program. It does not prevent a user from downloading a new program, but it does prevent them from seeing the program you have downloaded.

I/O Handling

Since the I/O is non-isolated 5 VTTL, are there any options for 24 VDC I/O?

Yes, there are a few options Animatics provides cables with built in 5 V to 24 V isolated logic circuits right in the connector hood. This allows the user to have a choice of either 4 Inputs and 3 Outputs or 5 Inputs and 2 Outputs at 24 VDC. They can be set as sinking or sourcing. The CBLIO-ISO1 series cable can be purchased in lengths from 3 to 10 meters. The DINIO7 is a DINrail mount breakout board that also provides a means of isolation using Industry Standard Opto-22, Gordos, or Grahill I/O modules such as ODC, IDC, OAC and IAC series. The DINIO7 also allows interconnection to other motors and their I/O via a built-in back plane.

Are there any Expanded I/O options?

Yes. Each Class 5 SmartMotor has the-AD1 option providing an additional 10 channels of isolated 24V sourcing I/O. This option will appear as an additional 12 pin 12mm connector where 24VDC must be supplied to make it work. Each channel may be configured as Sourcing Input, Sourcing Output, or 10 bit analog input. As analog inputs, they may be read over the range of 0-5VDC or zero to full supply rail. The Analog reading returns either raw binary value or millivolts directly.

All I/O pins are reverse voltage, over current, and short circuit

protected. A fault on an I/O pin requires a down power reset.

What type of electrical protection/isolation does each I/O pin have?

Each I/O pin has a 100 Ohm series current-limit resistor tied to a 5.6 VDC over-voltage limiting zener diode. The user ties into the 100 Ohm resistor directly. The connection between the 100 Ohm resistor and zener diode ties in directly to the CPU pin. This is why the motors are limited to 5 VTTL I/O logic levels only. Animatics does, however, provide 24 VDC I/O adapters and adapter cables for converting the 5 VDC I/O to optically isolated 24 VDC logic for connection to PLCs and other equipment. Please visit the Animatics website and search under Cables and Accessories.

Power Supplies

Which is better, Linear or Switcher Supplies?

Linear supplies are better suited for inductive loads. SmartMotor™ servos are inductive loads. Linear supplies can handle high current surges typically caused by starting and stopping of servo motors.

However, linear supplies have what is known as voltage droop.

This is characteristic of voltage dropping down with an increase in load. Typically, unregulated toroidal transformer supplies will drop 4 to 7% and E-Core types (the big square transformers) are >10%. Switchers have no voltage droop until they reach maximum load. Then they just drop completely to zero volts.

However, since they maintain a tight control over voltage up to the trip point, they can typically aid greatly in reaching maximum speed and acceleration of a given servo. However, the switching supply must be sized for the maximum expected peak current draw of the motor system. A linear supply only needs to be sized for continuous load. Linear supplies have a large capacitance to supply much higher current surges when needed, so this is more of an application specific question.

What concerns are there with maximizing voltage on the supply?

The higher the voltage, the faster the SmartMotor can move and the faster it can accelerate. This is a good thing. However, in conjunction with this, the higher the voltage, the closer you get to a peak voltage that can cause over-voltage breakdown of the controller. Also, the higher the voltage, the faster a rate of change of current can occur. It is a risk with any application to get faster response by moving towards a higher voltage.

Typically speaking, it is the dynamics of sudden changes that increases risk by a "x²" factor whereas the continuous load risk is only a direct ratio increase. This is because rate-of-change in current is proportional to acceleration which is the square of velocity, i.e. x². For safety sake, a 42 VDC supply for a 48 VDC system gives good margin with little speed losses.

How do I size Power Supplies?

The quick answer is "more is better".

First, be sure you have the correct SmartMotor for the job. Once that has been done, take the nominal power rating for that motor and you should size a LINEAR supply to provide about 10% more power to allow for longer sustained current loads. Any LINEAR supply will typically provide more than enough peak current. This is where sizing gets tricky with Switch-Mode Power supplies. "SWITCHERS" typically come with some rated voltage and current.

For example: 48 VDC at 6 Amps.

Well, that is just it...this can provide 48 VDC nailed to the wall all the way up to 6 Amps, but if any more current is applied, the power supply will drop out to zero VDC and typically reset. Any time you wish to use switchers, you need to take the peak expected load of the motor and size the switcher's continuous rating for that contingency.

As a rule of thumb, any 23 NEMA Frame SmartMotor™ can pull as much as 12 Amps instantaneous. Most 23 Frame SmartMotor servos will not pull more than about 9 Amps instantaneous. A 10 Amp switcher can supply any 23 frame SmartMotor for MOST applications. With a 34 frame SmartMotor will require a 20 Amp continuous rating to be sure you will not get a tripped power supply. 34 frame SmartMotor can pull as much as 40 Amps or more for a few milliseconds, so as originally stated: "Bigger is better," especially when it comes to switchers.

Back EMF

How do I protect against Back EMF?

Short Answer: Don't back-drive the SmartMotor.

The problem is back-driving the SmartMotor isn't the only means to produce Back EMF. Read the FAQ on "What is Back EMF and where does it come from?" The best way to protect against Back EMF is to use a shunt such as the active 48 VDC 100 Watt shunt supplied by Animatics. It drops a 100 Watt load onto the bus any time bus voltage exceeds 49.5 VDC. It removes the load when bus voltage goes back down below 46 VDC.

It will work with Switching or Linear supplies as long as no-load voltage does not stay above 48 VDC. Otherwise the shunt will be on all the time. Another method of protection is to use a mechanical brake controlled by the brake commands in the motor. The SmartMotor can respond to a fault and send a signal to the brake within 250µseconds to help hold the shaft from back driving. None of these ideas help against hitting a hard stop. Please read the next FAQ for more.

What is Back EMF and where does it come from?

Back EMF is the voltage generated when a rotor is moving within the stator of any motor. It is literally the motor acting as

a generator. There is a common rule that Back EMF or voltage generated is proportional to velocity. This is true in a constant velocity condition only. Back EMF is actually proportional to the rate of change of magnetic flux (magnetic field strength) inside the stator windings of the motor. The faster the rate of change, the higher the voltage rises. In other words, RPM of the motor shaft does not have to be that high to have very high voltages created.

Take any relay coil or solenoid valve coil in a 24 VDC system for example. When it is energized, the magnetic field pulls in the contactor or pilot valve. The magnetic flux reaches saturation and a DC electromagnet is then formed. When the power is removed from the coil, the magnetic flux rapidly collapses because there is no forward voltage to maintain it. Since the circuit is not electrically open, there is nothing to prevent the magnetic flux from collapsing rapidly at a hyperbolic rate. The result is something called "inductive-kick".

The "The inductive-kick" or spike in voltage for a 24 VDC coil can reach very high voltages and currents on the order of 100 times that of the original applied voltage, i.e. 2400 VDC! This is why it is very common to place reverse polarity diodes across relay coils and solenoid valve coils. It protects the system from high voltage spikes. The same thing occurs when a SmartMotor hits a hard stop. Suddenly, the rate of change of magnetic flux in the stator windings skyrockets upward because the rotor stopped moving. This sudden change causes an excessive voltage and current spike in the controller and can damage components.

What can we do about it? Practically speaking, not much. We could design the drive stage to be able to take the hit of a fast hard stop, but the drive stage would be very large. The controller would have a lot more components in it and the practicality of it would be diminished. The SmartMotor would grow in size for the same torque output to three times larger. This is just not practical.

I was told the SmartMotor™ failed due to over-voltage, but I never back drove it or ran it fast...

HARD STOP CRASHES:

The best recommendation for preventing damage to the SmartMotor/controller in the case of hitting a hard stop is to place a limit switch near the hard stop that trips the motor off line just prior to hitting the stop. The best way to prevent it beyond that is to prevent the cause of hitting the hard stop in the first place.

If this is due to jogging the SmartMotor in Velocity Mode and not letting the jog switch in time, then jog in Position Mode instead and use the "X" or "S" command to stop the SmartMotor when the jog switch is released. In any case, ***much care should be taken to be sure the SmartMotor is not intentionally or unintentionally allowed to hit a hard stop while under normal speeds and load conditions.***

⚠ Warning: Improper Power Supply Sizing may result in Motor Position Error Faults, Motor Resets, and Machine Faults ⚠

Communications

I have a SmartMotor that will not communicate no matter what I try. What should I do?

It is possible to unintentionally write and download a program that will lock up the CPU or prevent serial communications. If you power it up and there is one or more LED lit up, then try the following: Isolate the SmartMotor such that you have a single motor power and communications cable between the SmartMotor and the PC. Connect the motor to the PC serial port, but DO NOT power up the SmartMotor. In other words, have the power supply either disconnected or turned off. Then start up the SMI software and click on the TOOLS drop-down menu.

Under TOOLS, click on "Communications Lock-up Recovery" and a pop-up window will tell you to do what is described above. Then click NEXT. The Lock-up recovery utility will begin transmitting multiple "E" characters to the motor. It will tell you to power-up the SmartMotor at this point.

Then it will wait about one second and attempt to establish communications. If it does establish communications, it will tell you and then prompt you to either clear the program or upload a new program. At this point, it is advisable to clear the EEPROM to down-power reset the motor and reestablish communications normally. This way you will know if it was just a program issue or a hardware issue.

If you apply power and there are no LEDs lit up on the motor, then there is a major problem with it electrically. It will have to be sent back for repair.

Occasionally I lose communications and don't know why. What could be causing this?

Here are some general things to consider:

- Shielding and grounding must be done properly to insure good signal integrity.
- Long character strings should be avoided. The receive buffer is only 16 bytes long.
- Never use the shield as the ground reference connection for RS-232 or RS-485.
- Make sure there are no non-terminating strings being transmitted. If a string is not followed by a carriage return or space character, the SmartMotor will hang indefinitely while waiting on the terminating character. It is done this way to allow priority to the serial ports over any downloaded program execution.

How far can I transmit on RS-232 or RS-485?

"RS" in the RS-232 and RS-485 specification means "Recommended Standard." Not every company or chip manufacturer actually meets the "RS." The IEEE specification states that RS-232 single-ended signal is SUPPOSED to be +/-12 VDC or a 24 VDC swing from logic zero to logic 1. The specification for RS-485 is +/-5 VDC differential. By voltage levels, RS-232 will logically be able to transmit much further.

By noise immunity, a differential signal should be able to reach its destination "cleaner". The reality is similar to the following analogy: a clean whisper can't be heard a mile away, but a loud guttural voice can. RS-232 can transmit further but RS-485 transmits cleaner.

Also note that the higher the voltage level, the higher the induced noise must be to overcome the signal, so RS-232 isn't so bad after all. As far as actual distance goes, there are applications in the field running 250 feet on RS-232. RS-485 can't drive the cables well enough to go beyond 100 feet without experiencing loading problems. Also, RS-485 is a parallel bus. The more motors you add, the shorter the overall practical distance due to bus loading. RS-232 is serial. Therefore, one motor transmits directly to only one "receive" buffer. This means compounded bus loading does not occur, another reason RS-232 can actually transmit further.

I'm using Profibus between multiple SmartMotors and the communication sometimes drops out or does not initialize in the first place. What might be the cause?

First, Check your baud rate and cable lengths between nodes:

To use baud rates at or above 1.5 Mbps, special connectors ARE required. These connectors must have built in inductors in order to run these higher rates over Profibus. Additionally, the minimum cable length between two node MUST BE 1M (3 feet). If the cable is too short, reflected impedance can cause loss of communications data packets and spurious node errors. Branch lines are not permitted when using Baud rates greater than 1.5 Mbps. For more about Profibus and the SmartMotor, see page 23.



WARNING

Important Information, please read carefully

Class 5 SmartMotor™ servos may be used as upgrades to replace older Class 4 series SmartMotor Servos. However, there are some syntax differences. The SMI software has a code converter that will convert Class 4 code for you. However, it may require manual editing to maintain proper distances, velocities and accelerations.

Additionally it may require changes to following error limits and PID tuning parameters. Please consult the User's Guide and help files as necessary.

Note: It is not recommended to mix Class 4 and Class 5 motors on the same serial daisy chain.

Do not run Class 4 motors in contouring mode with Class 5 motors on the same daisy chain. It WILL NOT WORK!

SmartMotor Hardware and Control Limitations

Each SmartMotor is an integrated motion controller, drive amplifier and motor.

As with any motion controller, care should be taken with regard to connections, communications, and control. Proper grounding and shielding techniques should be observed and utilized.

Standard SmartMotor Controller & Drive Specifications:

All standard SmartMotor servos should be powered from 18VDC to 48VDC. Under no circumstances should they be allowed to run off of any higher voltages. Lower voltages could cause a brownout shutdown of the CPU or what would appear as a down power reset under sudden load changes. If power is reversed on any standard SmartMotor, immediate damage WILL occur and the SmartMotor will no longer operate.

Note: During hard fast decelerations, a SmartMotor can pull up supply voltages to the point of damage if a shunt resistor pack is not used.

NOTE (For IP SEALED MOTORS):

Drive Power and Control Power are Separate Inputs. Control power is rate max range of 18 to 32VDC.
Drive Power is from 18 to 48VDC max.

CPU Power:

All SmartMotor servos have an internal 5VDC power supply to run the internal CPU. This supply can be easily damaged if an external voltage source of a higher potential is applied. Do not exceed 5VDC on and I/O pin or 5VDC pin on any SmartMotor.

I/O Restrictions and Limitations:

Each on-board I/O pin has a minimum amount of protection consisting of a 100-Ohm current limit resistor and a 5.6VDC Zener diode. Each I/O pin also has a 5Kohm pull-up resistor. When assigned as outputs, they act as a push-pull amplifier that drives hard to either the positive or negative 5VDC rail. This means they are not open-collector I/O pins. Each I/O pin can sink and source up to 25mA. Exceeding this could result in damage

to the I/O port.

Communications:

Each SmartMotor has a 2 wire RS-232 port. This port meets IEEE standards with full +/- 12VDC potential on the transmit line. Proper serial ground signal referencing and shielding techniques should be used. Under no circumstances should the shield of a cable be used for the RS-232 ground reference. This could result in noise or corrupt data as well as ground loops that could damage the serial port chip set.

Each SmartMotor boots up default to the ECHO_OFF state. This means that nothing received is transmitted or echoed back out.

This is important to remember in serial "daisy-chain" set-ups. They also boot-up defaulted to base address zero meaning they will listen and respond to any incoming valid SmartMotor commands.

Hardware Protection Faults:

All Class 5 SmartMotor protection faults (over Current and over Temp) result in dynamic braking on error. This means the windings are shorted out to dissipate power as fast as possible.

WARNING

All motors WILL trip on thermal limit at 85Deg.C. They will not reset until cooling back down below 80Deg.C. The SmartMotor should be operated between 0 and 85Deg.C. The non-condensating. In other words, reaching dew-point can cause moisture to condense on the encoder disk causing loss of integrity of position feedback. SmartMotor should not be started up cold below zero Deg. C.

Software Protection Faults:

Limit switch inputs and position error limits are both "software" protection faults. This means they are not firmware unchangeable. The effects of Limit Switches and Position Error can be changed via valid software commands or set-up parameters.

Position Error is predicated by a value set by the user and can drastically effect SmartMotor response under varying load conditions and tuning. Limit switches can be set up to cause the SmartMotor to servo in place instead of free wheel. Refer to specific firmware addenda for various limit switch options and capabilities.

Motor Torque Limits: AMPS Command and T (Torque) Command

Motor T (torque) command is only for use in Mode Torque (MT). It has no effect on motor operation outside of Mode Torque.

The AMPS command has effect over all other modes of operation. It limits absolute maximum power available from the drive amp to the motor windings as a function of percent duty cycle of PWM (Pulse Width Modulation). The AMPS command should be used when it is desired to limit motor torque to a sensitive or torque input limited load. It may also be used to reduce the chance of reaching peak over current errors on high acceleration applications.



WARNING

Important Information, please read carefully

Error Handling, Motor Status Bits & Internal Conditions:

SmartMotors have many 16 Bit status words that contain interrupt registers triggered by selected events. These events include Position Errors reached, Over Current reached, Limit Switch conditions, Syntax errors and so on. In addition, in the newer SmartMotor servos, Bus Voltage, Drive Current, and SmartMotor Temperature are also available. By proper use of these status bits very simple and very flexible error handling can be achieved. Motors can be made to respond under varying load conditions in different ways and recover from any given software or hardware fault in a controlled manner.

Switching Power Supplies:

Most switchers will go into an OFF state on over-voltage. Few of them have a buck-regulator that prevents over-voltage. The ones that do are very costly and large. Always use a Shunt when using a switching power supply to aid in suppression of bus overvoltage. Switching power supplies should be sized to provide maximum expected current for the entire motor system under the worst load considerations. This is because switchers have no "reserve" like linear power supplies do. When they reach maximum current, they shut down or reset.

Warning: Improper Power Supply Sizing may result in Motor Position Error Faults, Motor Resets, and Machine Faults

Mechanical Brakes:

Any time the load can be easily back driven or is in a vertical orientation, an electromechanical fail-safe brake is highly recommended. Under no situation should a PLC or external controller be used to control a fail-safe brake on a servo. The response time will be diminished to the point of defeating protection. Instead, use the SmartMotor interrupt control features stated here:

Use the EOBK() command in conjunction with the BRKTRJ or BRKSRV commands:

- EOBK() command can assign the brake function to any I/O pin. value is -1 to disable.
- BRKENG - engage brake immediately, disable drive
- BRKRLS - release brake immediately. Warning: motor may freewheel.
- BRKTRJ - motor engages brake at end of trajectory. Releases when new move started.
- BRKSRV - motor engages brake when drive turned off due to OFF command or fault.

In making use of selected commands from above, the brake will get a signal to engage (be de-energized) within 250 to 500 microseconds of its trip condition. Using the PLC will cause a delay of anywhere from 4 to 10 milliseconds due to scan time, process time and brake release time. By then, the current in the control could have already well exceeded limits.

Position Error Limits:

Let's suppose you have a maximum allowable position error limit of 1000 encoder counts. The SmartMotor can hit a hard stop and go up to 999 encoder counts into position error before a trip condition is met.

The time it takes to get to that position error may be slow or fast depending on the speed you are moving.

Set "EL" to the lowest value possible to allow continued machine operation without spurious position error faults occurring.

Amplifier Tuning:

Let's suppose you have "tight" tuning of $KP > 3000$ or so and $KD > 20000$ or so. This is just an example of slightly tight tuning, but not too high. The higher the numbers, the faster motor current will rise under a given increase in position error. Collectively, with the above mentioned facts about "E" maximum allowed position error, the current may rise much faster. It is best to ratio acceptable tuning values with good Position Error values so as to maintain the lowest running position error with the lowest value of "EL" possible. The ironic thing here is that usually to get decrease following error implies increasing tuning. This is true, but for example: KV (velocity feed forward) and KA (acceleration feed forward) are better means to achieve this goal.

These tuning values lower position error while moving without increasing motor current because they shift the motor position command forward in the trajectory for the entire move, compared to during the dynamics of changes in moves. As a result, you get lower peak currents in the motor.

Power Supply Voltage Levels:

The higher the voltage, the faster the motor can move and the faster it can accelerate. This is a good thing, but in conjunction with faster acceleration, the higher the voltage, the closer to a peak voltage for over-voltage breakdown of the controller. Also, the higher the voltage, the faster a rate of change of current can occur. It is a risk with any application to get faster response by moving towards a higher voltage. Typically speaking, it is the dynamics of sudden changes that increases risk by a "x²" factor whereas the continuous load risk is only a direct ratio increase. This is because rate-of-change in current is proportional to acceleration which is the square of velocity, i.e. x^2 . For safety sake, a 42VDC supply for a 48VDC system gives good margin with little speed losses.

NOTE: Drive Power and Control Power are Separate Inputs. Control power is rate max range of 18 to 32VDC.

Drive Power is from 18 to 48VDC max.

Firmware Safety Control Options:

The firmware has the ability to suppress Back-EMF voltages any time the calculated trajectory has been exceeded by actual motor motion. In other words, the processor is looking at where it should be compared to where it actually is. Any time the motor exceeds dynamic position per calculated trajectory, the drive amplifier shunts power to maintain dynamic position control. As a result, excessive currents are suppressed at a rate of response of ~250 micro seconds.

Additionally, if the motor faults out for either Position Error, Travel Limit, or Thermal Limits, it will automatically short out the windings and dynamically stop the shaft.



Conformity Statement

OVERVIEW
MOTOR SPECIFICATIONS
LINEAR SYSTEMS
CONNECTIVITY
PERIPHERALS
IP 65 MODELS & CONNECTIVITY
POWER SUPPLIES & SHUNTS
GEAR HEADS
SOFTWARE
APPENDIX

Animatics Corporation and subsidiaries, collectively "Animatics", assembles and/or manufactures products and systems which are components of machines and final systems that are made by other companies. As such, Animatics considers that it is exempt from the standards applicable to such final machine and systems builders. Nonetheless, as an accommodation only, Animatics has used standards as outlined herein as a part of its quality assurance program.

Animatics Corporation and subsidiaries product and systems designs and engineering is done to standards such as CE, EU, DIN, and the like. Such standards include Applied Harmonized Standards and Applied National Standards and electrical (under 50V), mechanical and machine design standards. The following are some of the standards applicable to our products and systems known as the SmartMotor™, Servida™, OEM Dynamics™, and private labeled rotary and linear systems and accessories.

ELECTRICAL

EMC

EN 50081-1:1992, *Electromagnetic compatibility-Generic emission standard*

CISPR 22:1987/ EN55022:1987, Class A, *Limits and methods of measurement of radio interference characteristics of information technology equipment.*

EN 50082-1:1994, *Electromagnetic compatibility- Generic immunity standard*

EN 61000-4-2, *Electrostatic discharge immunity test*

EN 61000-4-3, *Radiated, radio frequency electro-magnetic field immunity test*

EN 61000-4-4, *Electrical fast transient/burst immunity test*

EN 61010-1:1993 *Safety requirements for electrical equipment for measurement, control, and Laboratory use.*

MACHINERY (including linear products and systems such as actuators, slides, stages, etc.)

According to EC Directive on Machinery 98/37/EG

According to EC Directive on Machinery EMC 2004/108/EC
Applied Harmonized Standards

EN ISO 12100-1:2003-11

Safety of machinery-Basic concepts, general principles for design

Part 1: Basic terminology, methodology

Part 2: Technical principles

Applied National Standards and technical specifications, especially:

World sourced components are made to:

DIN, ABEC, ISO, CE and so called UL applicable standards such as:

UR 1004

EN 12020-2:2001;

ISO 3408-3-1992; ISO-7380-A; ISO230-2,

DIN912A2; DIN7984-A2;

ASME Y14.5M-1994; ASME Y14.41-2003.

Comment: 1) Products can be made to comply with CE Medical Device Directive S2-93, TUV mark applications, and more. More information on conformity standards may be found at www.animatics.com/literature. 2) Animatics uses or has used independent testing laboratories such as a) Underwriters Laboratories Inc. ("UL"), b) Bay Area Compliance Labs ("BACL") and other U.S. and European companies to supplement its own testing capabilities. For more information go to <http://animatics.com/web/literature.html>

January 31, 2011

James V. Hawkins

President, Animatics Corporation



Warranty Statement

Animatics warrants to Customer that Products purchased hereunder will conform to the applicable manufacturer's specifications for such Products and that any value-added work performed by Animatics on such Products will conform to applicable Customer's specifications relating to such work for a period of 1-2 years from the date of purchase. Animatics makes no other warranty, express or implied, with respect to the Products.

IN PARTICULAR, ANIMATICS MAKES NO WARRANTY RESPECTING THE MERCHANTABILITY OF THE PRODUCTS OR THEIR SUITABILITY OR FITNESS FOR ANY PARTICULAR PURPOSE OR USE OR RESPECTING INFRINGEMENT. However, Animatics will transfer to Customer whatever transferable warranties and indemnities Animatics receives from the manufacturer of whatever transferable warranties and indemnities Animatics receives from the manufacturer of the Products. With respect to value-added work by Animatics which does not meet applicable Customer's specifications, Animatics'

liability is limited (at Animatics election) to (1) refund of Customer's purchase price for such Products (without interest), (2) repair of such Products, or (3) replacement of such Products; provided, however, that such Products must be returned to Animatics, along with acceptable evidence of purchase, within twenty (20) days from date of delivery, transportation charges prepaid.

CUSTOMER SHALL NOT IN ANY EVENT BE ENTITLED TO, AND ANIMATICS SHALL NOT BE LIABLE FOR INDIRECT, SPECIAL, INCIDENTAL OR CONSEQUENTIAL DAMAGES OF ANY NATURE INCLUDING, WITHOUT BEING LIMITED TO, LOSS OF PROFIT, PROMOTIONAL OR MANUFACTURING EXPENSES, OVERHEAD, INJURY TO REPUTATION OR LOSS OF CUSTOMERS. CUSTOMER'S RECOVERY FROM ANIMATICS FOR ANY CLAIM SHALL NOT EXCEED CUSTOMER'S PURCHASE PRICE FOR THE PRODUCTS IRRESPECTIVE OF THE NATURE OF THE CLAIM WHETHER IN CONTRACT, TORT WARRANTY, OR OTHERWISE.

USE OF PRODUCTS IN LIFE SUPPORT AND NUCLEAR APPLICATIONS.

Products sold by Animatics are not designed for use in life support or nuclear applications. Animatics' customers using or selling Products for use in life support or nuclear applications do so at their own risk, agree that Animatics and the manufacturer of the Products are not liable, in whole or in part, for any claim or damage arising from such use, and agree to fully indemnify,

defend and hold harmless Animatics and the manufacturer of the Products from and against any and all claims, damages, loss, cost, expense or liability arising out of or in connection with the use or performance of Products in life support or nuclear applications.

All integrated motor products made by Animatics are covered by patent number 5,912,541.

Patents are in progress worldwide on all Harmonic Drive Products and all rights are reserved as to OEM Dynamics linear products and systems.

Actuators and Harmonic Linear Drive units have a 1 year warranty

SmartMotors have a 2 year warranty



The Animatics name and logo, the Animatics logo are registered trademarks of Animatics Corporation incorporated in the U.S.A. and other countries. Animatics™, OEMDynamics™, AniLink™, Animatics Legend Series™, Animatics OEM Series™, Harmonic Linear Drive™, Integrated SmartMotor™, JenCNC™, RTC 1000™, RTC 3000™, RTC 4000™, SmartActuator™, SmartBox™, SmartBoxBCD™, SmartMachine Systems™, SmartMotor™, Smart Select™, Smart Select Interface™, Smart Select Software™, SmartTechnologies™, SMEngine™, SMNC™, and Servida™ are trademarks of Animatics Corporation incorporated in the U.S.A.

All other trademarks mentioned herein are the property of their respective companies.

Information subject to change. © 2011, Animatics Corporation, Inc. All rights reserved. Printed in the U.S.A.

Follow these easy rules to assure success in using the Animatics SmartMotor™ to maximize your system's reliability. Please take a minute to see that your system design and implementation pass the test. Keep this page handy to document your settings and send it along with any motors returned for inspection or repair.

1. Power supply selection is very important.

- Provide for a means to keep the SmartMotor's voltage below 48 VDC by...
 - operating at 48 VDC or less as nominal or,
 - using a shunt near the motor or,
 - adding a shunt to a switching power supply or,
 - operating at 48 VDC or less and adding a shunt for a vertical application.

NOTE: Drive Power and Control Power are Separate Inputs. Control power is rated to a maximum range of 18 to 32VDC. Drive Power is from 18 to 48VDC max.

2. Proper electrical interfacing is essential.

- Refrain from creating any ground loops with the communications by...
 - isolating the ground prong of the host PC for a single motor application or,
 - isolating the motor's power supply for a single motor application or,
 - using a communication isolation product to protect each axis or,
 - operating only smaller motors at low power, like short SM23s or smaller.
 - this does not apply when employing no serial communications at all.
- Refrain from creating any ground loops with the SmartMotor's I/O by...
 - using the main or 5V power at the motor to operate any sensors or,
 - using an opto-coupler to interface to the inputs or outputs or,
 - using an I/O isolation product or,
 - operating only smaller motors at low power, like short SM23s or smaller.
 - this does not apply when employing no I/O connections at all.



3. Properly sizing an Animatics SmartMotor™ for the application is critical.

- Determine that the motor selected has the torque to handle the friction.
- Determine that the motor selected has the torque to support any vertical component of the load.
- Determine that the motor selected has the torque to accelerate the load.
- Determine that the motor's rotor inertia is properly matched to the load.

4. Considering the thermal environment for the SmartMotor is important.

- Consider the ambient temperature and avoid applications above 70°C ambient.
- Maximize the heat sinking capability of the motor's mount to any extent possible.

5. Proper mechanical and environmental implementation is needed.

- Assure motor shaft loading is within axial and radial limits. 
- Be certain that the motor does not get exposed to fluids or excessive moisture. 
- Insure relative humidity is <30% and non condensing.

Noise Filtering may be necessary

Ports 0, 1, 2, 3, and 6 are all classified as high speed input.

- 1. Ports 0 and 1:** Ports 0 and 1 may be configured as Phase A and B encoder input or Step and Direction input. To ensure proper operation when following external encoders, it is strongly advised to use Line Driver encoders or encoders with true push-pull drive capability. This allows up to 1.5MHz input frequency. Open Collector output encoders will not work above 20KHz or so typically due the inability to drive input capacitance well enough.
- 2. Ports 2 and 3:** Both Ports 2 and 3 default as Over Travel Limit inputs. They can be triggered by a negative edge transition as fast as 5 microseconds allowing optimum fail safe detection of over-travel. However, as a result, in noisy systems, it may require capacitive filtering to prevent false triggers from static or other induced noise.
- 3. Port 6:** Port 6 defaults as the "sync" or synchronous trigger input. This means any time it goes low, the processor issues a "G" command. The purpose of this is to allow pre-condition setup of motion profiles and then via hardware input the user may synchronize multiple motor/axis starts at the exact same time. However, similar to the Over Travel limit inputs, Port 6 can detect input pulses down to 5 microseconds. To ensure no false triggers, some system installs may require capacitive filtering to avoid false triggers. In all cases above, typical filtering is via 10 to 100 picofarad ceramic capacitors tied from the input pin to ground. This is only a recommendation; system characteristic may vary depending on surrounding equipment.



United States

Animatics Corporation
3200 Patrick Henry Drive
Santa Clara, CA 95054
USA

Phone: +1 408 748 8721
Fax: +1 408 748 8725
www.animatics.com
www.smartmotor.com
www.oemdynamics.com

Germany

Animatics GmbH
In der Neuen Welt 8/G5
87700 Memmingen
Germany

Phone: +49 (0) 8331 9278355
Fax: +49 (0) 8331 9278356
www.animatics.de
www.servida.de
www.servida.com

Japan

Kichijoji Nagatani City Plaza 601
1-20-1, Kichijojihoncho
Musashino-Shi, Tokyo 180-0004
Japan

Phone: +81 (0) 422 20 1251
Fax: +81 (0) 422 27 2764
www.animatics.jp
www.smartmotor.com



ANIMATICS®

Defining the future in motion control