

# IA240/241 Hardware User's Manual

---

Seventh Edition, July 2009

[www.moxa.com/product](http://www.moxa.com/product)

**MOXA**<sup>®</sup>

© 2009 Moxa Inc. All rights reserved.  
Reproduction without permission is prohibited.

# IA240/241 Hardware User's Manual

Any software described in this manual is furnished under a license agreement and may be used only in accordance with the terms of that agreement.

## Copyright Notice

Copyright © 2009 Moxa Inc.  
All rights reserved.  
Reproduction without permission is prohibited.

## Trademarks

MOXA is a registered trademark of Moxa Inc.  
All other trademarks or registered marks in this manual belong to their respective manufacturers.

## Disclaimer

Information in this document is subject to change without notice and does not represent a commitment on the part of Moxa.

Moxa provides this document “as is,” without warranty of any kind, either expressed or implied, including, but not limited to, its particular purpose. Moxa reserves the right to make improvements and/or changes to this manual, or to the products and/or the programs described in this manual, at any time.

Information provided in this manual is intended to be accurate and reliable. However, Moxa assumes no responsibility for its use, or for any infringements on the rights of third parties that may result from its use.

This product might include unintentional technical or typographical errors. Changes are periodically made to the information herein to correct such errors, and these changes are incorporated into new editions of the publication.

## Technical Support Contact Information

**[www.moxa.com/support](http://www.moxa.com/support)**

### Moxa Americas:

Toll-free: 1-888-669-2872

Tel: +1-714-528-6777

Fax: +1-714-528-6778

### Moxa China (Shanghai office):

Toll-free: 800-820-5036

Tel: +86-21-5258-9955

Fax: +86-10-6872-3958

### Moxa Europe:

Tel: +49-89-3 70 03 99-0

Fax: +49-89-3 70 03 99-99

### Moxa Asia-Pacific:

Tel: +886-2-8919-1230

Fax: +886-2-8919-1231

# Table of Contents

<b>Chapter 1</b>	<b>Introduction .....</b>	<b>1-1</b>
	Overview.....	1-2
	Package Checklist.....	1-2
	Product Features .....	1-3
	Product Hardware Specifications .....	1-3
	Hardware Introduction .....	1-4
	Appearance.....	1-4
	Dimensions.....	1-5
	LED Indicators .....	1-5
	Reset-type Buttons .....	1-5
	Real Time Clock.....	1-6
	Placement Options .....	1-6
	DIN-Rail Mounting .....	1-6
	Wall Mounting (optional).....	1-7
	Hardware Connection Description.....	1-8
	Wiring Requirements .....	1-8
	Connecting the Power .....	1-8
	Grounding the IA240/241.....	1-9
	Connecting to the Network.....	1-9
	Connecting to a Serial Device .....	1-9
	Connecting to the Console Port.....	1-10
	PCMCIA (IA241 only).....	1-10
	SD Interface.....	1-10
	USB .....	1-10
	DI/DO.....	1-10

Thank you for purchasing the Moxa IA240/241 RISC-based industrial ready-to-run embedded computer. This product's features include four RS-232/422/485 serial ports, dual 10/100 Mbps Ethernet ports, 4 digital input channels and 4 digital output channels, a PCMCIA interface for wireless LAN communication, and SD interface and USB ports for mass storage disk expansion. These features make the IA240/241 series ideal for your embedded applications.

This manual introduces the hardware of the IA240/241 series embedded computers. After a brief introduction of the hardware features, the manual focuses on installation and hardware configuration with device interfaces.

The following topics are covered in this chapter:

- ❑ **Overview**
  - Package Checklist
  - Product Features
  - Product Hardware Specifications
- ❑ **Hardware Introduction**
  - Appearance
  - Dimensions
  - LED Indicators
  - Reset-type Buttons
  - Real Time Clock
- ❑ **Placement Options**
  - DIN-Rail Mounting
  - Wall Mounting (optional)
- ❑ **Hardware Connection Description**
  - Wiring Requirements
  - Connecting the Power
  - Grounding the IA240/241
  - Connecting to the Network
  - Connecting to a Serial Device
  - Connecting to the Console Port
  - PCMCIA (IA241 only)
  - SD Interface
  - USB
  - DI/DO

## Overview

The IA240/IA241 embedded computers, which are ideal for industrial automation applications, feature 4 RS-232/422/485 serial ports, dual Ethernet ports, 4 digital input channels, 4 digital output channels, and a PCMCIA cardbus and SD socket in a compact, IP30 protected, industrial-strength rugged casing. The DIN-Rail vertical form factor makes the IA240/241 a cost effective solution for installation in small cabinets. This space-saving solution also facilitates easy wiring, and is the best choice of front-end embedded controller for industrial applications.

In addition to the standard model, the IA240/IA241 also comes in wide temperature models. The IA240-T and IA241-T have an operating temperature range of -40 to 75°C, and are appropriate for harsh industrial automation environments. The industrial mechanism of the IA240/IA241 design provides robust, reliable computing. Due to the RISC-based architecture, the IA240/IA241 will not generate too much heat while being used. The high communication performance and fanless design make the IA240/IA241 ideal for industrial automation environments.

The IA240/241 embedded computers use a Moxa ART ARM9, 32-bit, 192 MHz RISC CPU. Unlike the X86 CPU, which uses a CISC design, the RISC design architecture and modern semiconductor technology provide the IA240/241 with a powerful computing engine and communication functions, but without generating a lot of heat. The built-in 16 MB NOR Flash ROM and 64 MB SDRAM give you enough memory to run your application software directly on the IA240/241. As the dual LAN ports are built right into the Moxa ART ARM9 CPU, the IA240/241 is an ideal communication platform for Network Security applications. If your application requires placing the IA240/241 at a site that is not located near an Ethernet LAN connection, you can connect to the network by using the IA240/241's PCMCIA port to attach a wireless LAN card. For applications that require an even longer transmission distance, use the GPRS or UMTS cards.

## Package Checklist

All models of the IA240/241 series are shipped with the following items:

- 1 IA240/241 Embedded Computer
- Wall-Mounting Kit
- DIN-Rail Mounting Kit (attach to the product's casing)
- Quick Installation Guide
- Document & Software CD
- Cross-over Ethernet cable
- CBL-RJ45M9-150: 150 cm, 8-pin RJ45 to Male DB9 serial port cable
- CBL-RJ45F9-150: 150 cm, 8-pin RJ45 to Female DB9 console port cable
- Universal Power Adapter
- Product Warranty Statement

*NOTE: Notify your sales representative if any of the above items are missing or damaged.*

## Product Features

- Moxa ART 32-bit ARM9 industrial communication processor
- 64 MB RAM on-board, 16 MB Flash Disk
- 4 RS-232/422/485 serial ports
- 4-ch digital input and 4-ch digital output
- Dual 10/100M Ethernet for redundant networking
- PCMCIA, wireless LAN Expansion (supports 802.11b/g)
- SD socket for storage expansion
- Ready-to-Run Linux Communication Platform
- “Software Lock” function to protect your application program
- DIN-Rail installation; wall-mount installation is also possible
- Robust, fanless design; IP30 protection mechanism
- -40 to 75°C wide temperature models available

## Product Hardware Specifications

	IA241 / IA241-T	IA240 / IA240-T
<b>CPU</b>	Moxa “ART” ARM9 32-bit CPU 192 MHz	
<b>RAM</b>	64 MB	
<b>Flash</b>	16 MB	
<b>OS</b>	Linux	
<b>LAN</b>	Auto-sensing 10/100 Mbps x 2 with built-in 1.5 KV magnetic isolation protection; RJ45 Connector	
<b>Serial Ports</b>	RS-232/422/485 × 4, RJ45 Connector	
<b>Serial Protection</b>	15 KV ESD for all signals	
<b>Data Bits</b>	5, 6, 7, 8	
<b>Stop Bits</b>	1, 1.5, 2	
<b>Parity</b>	None, Even, Odd, Space, Mark	
<b>Flow Control</b>	RTS/CTS, XON/XOFF, RS-485 ADDC™	
<b>Speed</b>	50 bps to 921.6 Kbps	
<b>Serial Console</b>	RS-232 × 1, RJ45 Connector	
<b>DI/DO</b>	DI × 4, DO × 4	
<b>USB 2.0 Hosts</b>	1	
<b>PCMCIA</b>	Cardbus × 1**	N/A
<b>Storage Expansion</b>	SD × 1***	
<b>Watchdog Timer</b>	Yes	
<b>Real Time Clock</b>	Yes	
<b>Buzzer</b>	Yes	
<b>Reset Button</b>	HW Reset × 1, Reset to Default × 1	
<b>Power Input</b>	12 to 48 VDC	
<b>Power Consumption</b>	7W	
<b>Dimensions (W x D x H)</b>	60 × 100 × 137 mm	
<b>Weight</b>	500 g	430 g
<b>Operating temperature</b>	-10 to 60°C, (14 to 140°F), 5 to 95% RH -40 to 75°C, (-40 to 167°F) is optional (for -T models)	
<b>Storage temperature</b>	-20 to 80°C, (-4 to 176°F), 5 to 95% RH -40 to 85°C, (-40 to 185°F) is optional (for -T models)	
<b>Anti-Vibration</b>	1 g @ IEC-68-2-6, sine wave(resonance search), 5-500 Hz, 1 Oct/min, 1 cycle, 13 mins 17 sec/axis	

<b>Regulatory Approvals</b>	EMC: CE Class A, FCC Class A; Safety: UL, cUL, TÜV
<b>Warranty</b>	5 years

- \* USB Client function is reserved for future enhancement
- \*\* PCMCIA is designed for 802.11b/g wireless LAN card expansion
- \*\*\* SD is designed for Flash memory card expansion

## Hardware Introduction

### Appearance

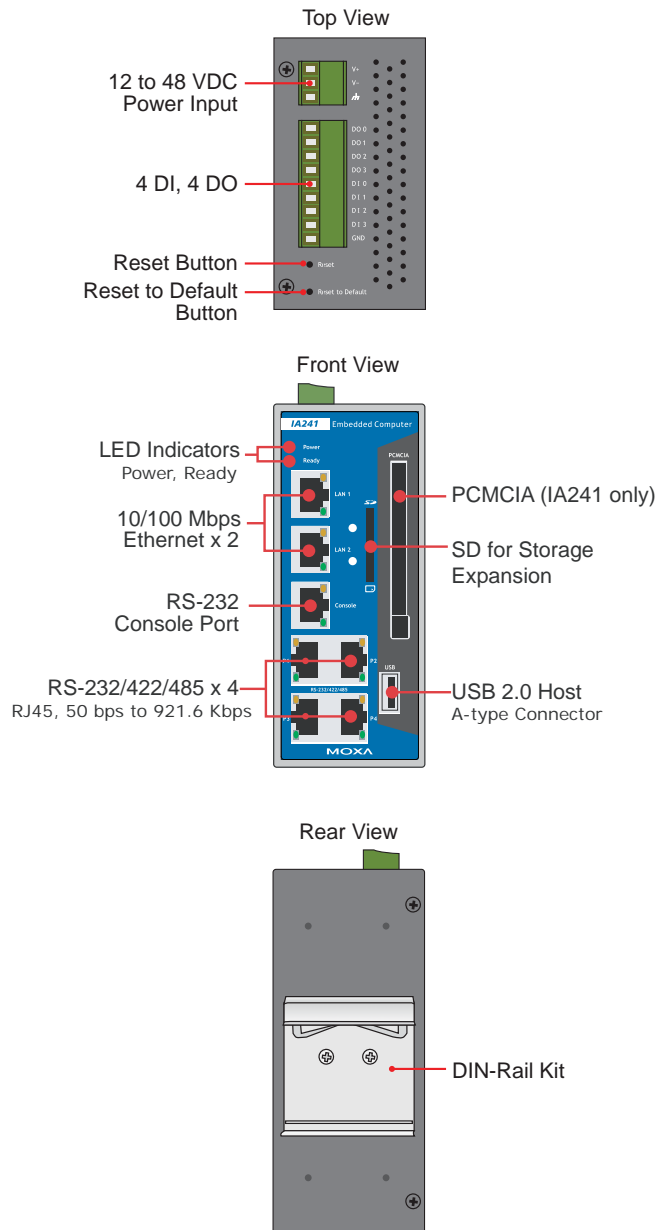

## Dimensions

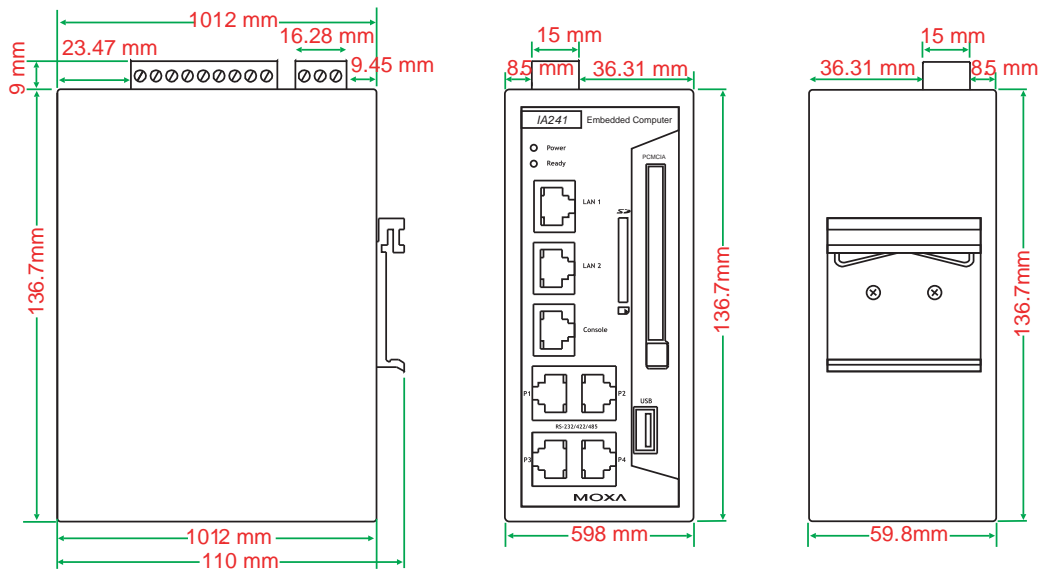

## LED Indicators

The IA240/241 has 16 LED indicators on the front panel. Refer to the following table for information about each LED.

LED Name	Color	Meaning
Power	Red	Power is ON.
Ready	Green	OS is ready and functioning normally (after booting up).
LAN1, LAN2	Orange	10 Mbps Ethernet connection
	Green	100 Mbps Ethernet connection
Console	Orange	Console port is receiving RX data from the serial device.
	Green	Console port is transmitting TX data to the serial device.
P1, P2, P3, P4,	Orange	Serial port is receiving RX data from the serial device.
	Green	Serial port is transmitting TX data to the serial device.

## Reset-type Buttons

The IA240/241 has two reset-type buttons. The button labeled **Reset** has the same effect as switching off the power and then switching the power back on. The button labeled **Reset to default** returns the IA240/241 to the factory default parameter configuration.

### Reset Button

Pressing the **Reset** button initiates a hardware reboot. The button plays the same role as a desktop PC's reset button.

In normal use, you should NOT use the **Reset** Button. You should only use this function if the software is not working properly. To reset an embedded Linux system, always use the software reboot command `/>reboot` to protect the integrity of data being transmitted or processed.



## Reset to Default Button

Press the **Reset to Default** button continuously for at least 5 seconds to load the **factory default configuration**. After the factory default configuration has been loaded, the system will reboot automatically. The **Ready** LED will blink on and off for the first 5 seconds, and then maintain a steady glow once the system has rebooted.

We recommend that you only use this function if the software is not working properly and you want to load factory default settings. To reset an embedded Linux system, always use the software reboot command `/>reboot` to protect the integrity of data being transmitted or processed. The **Reset to Default** button is not designed to hard reboot the IA240/241.



### ATTENTION

#### Reset to Default preserves user's data

The **Reset to Default** button will NOT format the user directory and erase the user's data. Pressing the Reset to default button will only load the configuration file. All files in the `/etc` directory will revert to their factory defaults, but other User Data will still exist in the Flash ROM.

## Real Time Clock

The IA240/241's real time clock is powered by a lithium battery. We strongly recommend that you do not replace the lithium battery without help from a qualified Moxa support engineer. If you need to change the battery, contact the Moxa RMA service team.



### WARNING

There is a risk of explosion if the battery is replaced by an incorrect type.

## Placement Options

### DIN-Rail Mounting

The aluminum DIN-Rail attachment plate is already attached to the product's casing. To attach the plate to IA240/241, make sure that the stiff metal spring is facing the top of the IA240/241, as shown in the following figures.

**STEP1:** Insert the top of the DIN-Rail into the slot just below the stiff metal spring.

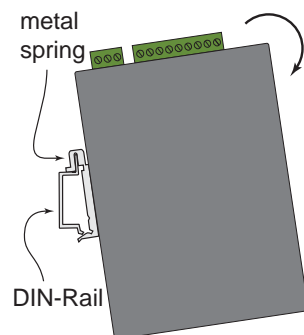

**STEP2:** The DIN-Rail attachment unit will snap into place as shown.

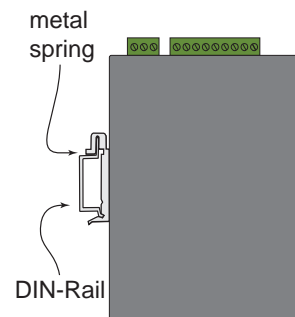

To remove the IA240/241 from the DIN-Rail, simply reverse Steps 1 and 2.

## Wall Mounting (optional)

For some applications, you will find it convenient to mount IA240/241 on the wall, as depicted by the following illustrations.

**STEP 1:**

Remove the aluminum DIN-Rail attachment plate from IA240/241's rear panel, and then attach the wall mount plates, as shown by the figures at the right.

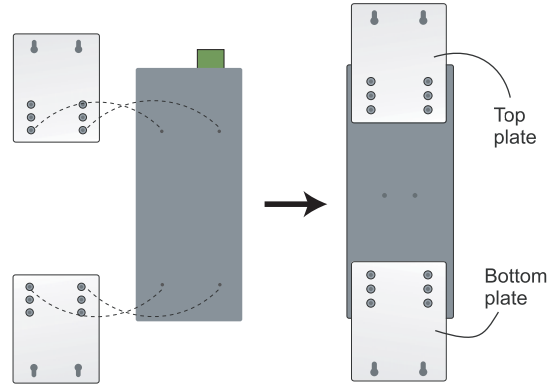

**STEP 2:**

Mounting IA240/241 on the wall requires 4 screws. Use the switch, with wall mount plates attached, as a guide to mark the correct locations of the 4 screws. The heads of the screws should be less than 6.0 mm in diameter, and the shafts should be less than 3.5 mm in diameter, as shown by the figure at the right.

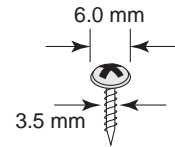

**NOTE** Before tightening the screws into the wall, make sure the screw head and shank size are suitable by inserting the screw into one of the keyhole-shaped apertures of the Wall Mounting Plates.

Do not screw the screws in completely—leave about 2 mm to allow room for sliding the wall mount panel between the wall and the screws.

**STEP 3:**

Once the screws are fixed on the wall, insert the four screw heads through the large parts of the keyhole-shaped apertures, and then slide IA240/241 downwards, as indicated. Tighten the four screws for added stability.

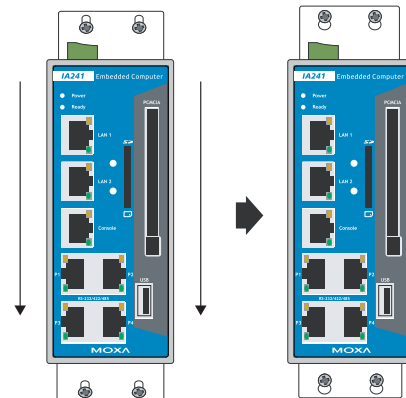

## Hardware Connection Description

This section describes how to connect the IA240/241 to serial devices for first time testing purposes. We cover **Wiring Requirements**, **Connecting the Power**, **Grounding the IA240/241**, **Connecting to the Network**, **Connecting to a Serial Device**, **Connecting to the Console Port**, **PCMCIA**, **SD Socket**, **USB**, and **DI/DO**.

### Wiring Requirements



#### ATTENTION

##### **Safety First!**

Be sure to disconnect the power cord before installing and/or wiring your IA240/241.

##### **Wiring Caution!**

Calculate the maximum possible current in each power wire and common wire. Observe all electrical codes dictating the maximum current allowable for each wire size.

If the current goes above the maximum ratings, the wiring could overheat, causing serious damage to your equipment.

##### **Temperature Caution!**

Be careful when handling the IA240/241. When plugged in, the IA240/241's internal components generate heat, and consequently the outer casing may feel hot to the touch.

You should also observe the following common wiring guidelines:

- Use separate paths to route wiring for power and devices. If power wiring and device wiring paths must cross, make sure the wires are perpendicular at the intersection point.  
**NOTE:** Do not run signal or communication wiring and power wiring in the same wire conduit. To avoid interference, wires with different signal characteristics should be routed separately.
- You can use the type of signal transmitted through a wire to determine which wires should be kept separate. The rule of thumb is that wiring that shares similar electrical characteristics can be bundled together.
- Keep input wiring and output wiring separate.
- When necessary, it is strongly advised that you label wiring to all devices in the system.

### Connecting the Power

Connect the 12 to 48 VDC power line to the IA240/241's terminal block. If the power is properly supplied, the Power LED will light up. The Ready LED will glow a solid green color when the operating system is ready (it may take 30 to 60 seconds for the operating system to boot up).



#### ATTENTION

This device is intended to be applied by a Power Supply, rated 12 to 48 VDC, 510 mA minimum requirements, and it cannot disassemble by operators or service people.

## Grounding the IA240/241

Grounding and wire routing help limit the effects of noise due to electromagnetic interference (EMI). Run the ground connection from the ground screw to the grounding surface prior to connecting devices.



### ATTENTION

This product is intended to be mounted to a well-grounded mounting surface, such as a metal panel.

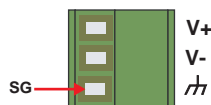

**SG:** The *Shielded Ground* (sometimes called *Protected Ground*) contact is the bottom contact of the 3-pin power terminal block connector when viewed from the angle shown here. Connect the SG wire to an appropriate grounded metal surface.

## Connecting to the Network

Connect one end of the Ethernet cable to one of the IA240/241's 10/100M Ethernet ports (8-pin RJ45) and the other end of the cable to the Ethernet network. If the cable is properly connected, the IA240/241 will indicate a valid connection to the Ethernet in the following ways:

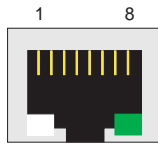

The LED indicator in the lower right corner glows a solid green color when the cable is properly connected to a 100 Mbps Ethernet network. The LED will flash on and off when Ethernet packets are being transmitted or received.

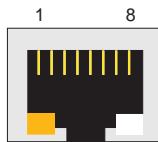

The LED indicator in the lower left corner glows a solid orange color when the cable is properly connected to a 10 Mbps Ethernet network. The LED will flash on and off when Ethernet packets are being transmitted or received.

Pin	Signal
1	ETx+
2	ETx-
3	ERx+
4	---
5	---
6	ERx-
7	---
8	---

## Connecting to a Serial Device

Use properly wired serial cables to connect the IA240/241 to serial devices. The IA240/241's serial ports (P1 to P4) use 8-pin RJ45 connectors. The ports can be configured by software for RS-232, RS-422, or 2-wire RS-485. The precise pin assignments are shown in the following table:

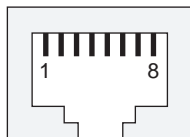

Pin	RS-232	RS-422	RS-485
1	DSR	---	---
2	RTS	TXD+	---
3	GND	GND	GND
4	TXD	TXD-	---
5	RXD	RXD+	Data+
6	DCD	RXD-	Data-
7	CTS	---	---
8	DTR	---	---

## Connecting to the Console Port

The IA240/241's console port is an 8-pin RJ45 RS-232 port. The port can be used to connect to the console utility from a remote console via a V90 or GPRS modem with PPP protocol. The pin definition is the same as for the serial ports (P1 to P4). For normal data acquisition applications, you should connect to IA240/241's serial ports (P1 to P4) via a V90 or GPRS modem. If you would like to use the console port for normal data acquisition applications, you can set the Console port to start up via PPP protocol.

## PCMCIA (IA241 only)

The PCMCIA slot supports the CardBus (Card-32) Card standard and 16-bit (PCMCIA 2.1/JEIDA 4.2) Card standard. It supports +3.3V, +5V, and +12V at a working voltage of 120 mA~1100 mA. Wireless LAN card expansion is optional. The wireless LAN card suggested by Moxa lets you connect the IA241 to a wireless LAN, with both 802.1b and 802.11g interfaces supported. If you need device drivers for other kinds of PCMCIA cards, contact Moxa for information on how to initiate a cooperative development project. The PCMCIA slot supports the CardBus Card standard and 16-bit Card standard. It supports at a working voltage of 120 mA. Wireless LAN card expansion is optional.

## SD Interface

Both the IA241 and IA240 provide an SD socket for storage expansion. Moxa provides an SD flash disk for plug & play expansion. It allows the user to plug in a Secure Digital (SD) memory card compliant with the SD 1.0 standard for up to 1 GB of additional memory space, or a Secure Digital High Capacity (SDHC) memory card compliant with the SD 2.0 standard for up to 16 GB of additional memory space. The SD socket is located on the front side of the IA240/241. To install an SD card, you must first remove the SD protection cover to access the socket, and then plug the SD card directly into the socket. Remember to push in the SD card first if you want to remove it.

## USB

The IA240/241 provides a USB 2.0 host. The IA240/241 provides a USB 2.0 host, which supports the ability to connect a flash disk or 2.5 inch hard drive for storing large amounts of data.

## DI/DO

The IA240/241 has a 4-ch digital input and 4-ch digital output. The digital input channels and digital output channels are on the same terminal block. The pinouts for the I/O are shown in the figure.

