

DA-660 Hardware User's Manual

Fourth Edition, December 2009

www.moxa.com/product

MOXA[®]

© 2009 Moxa Inc. All rights reserved.
Reproduction without permission is prohibited.

DA-660 Hardware User's Manual

The Hardware described in this manual is furnished under a license agreement and may be used only in accordance with the terms of that agreement.

Copyright Notice

Copyright © 2009 Moxa Inc.
All rights reserved.
Reproduction without permission is prohibited.

Trademarks

MOXA is a registered trademark of Moxa Inc.
All other trademarks or registered marks in this manual belong to their respective manufacturers.

Disclaimer

Information in this document is subject to change without notice and does not represent a commitment on the part of Moxa.

Moxa provides this document “as is,” without warranty of any kind, either expressed or implied, including, but not limited to, its particular purpose. Moxa reserves the right to make improvements and/or changes to this manual, or to the products and/or the programs described in this manual, at any time.

Information provided in this manual is intended to be accurate and reliable. However, Moxa Technologies assumes no responsibility for its use, or for any infringements on the rights of third parties that may result from its use.

This product might include unintentional technical or typographical errors. Changes are periodically made to the information herein to correct such errors, and these changes are incorporated into new editions of the publication.

Technical Support Contact Information

www.moxa.com/support

Moxa Americas:

Toll-free: 1-888-669-2872
Tel: +1-714-528-6777
Fax: +1-714-528-6778

Moxa China (Shanghai office):

Toll-free: 800-820-5036
Tel: +86-21-5258-9955
Fax: +86-10-6872-3958

Moxa Europe:

Tel: +49-89-3 70 03 99-0
Fax: +49-89-3 70 03 99-99

Moxa Asia-Pacific:

Tel: +886-2-8919-1230
Fax: +886-2-8919-1231

Table of Contents

Chapter 1	Introduction	1-1
	Overview.....	1-2
	Package Checklist.....	1-2
	Product Features	1-2
	Hardware Specifications.....	1-3
	Hardware Introduction	1-4
	Appearance and Dimensions	1-4
	Hardware Block Diagram.....	1-6
	LED Indicators	1-6
	Reset-type Buttons	1-7
	LCM Screen	1-7
	Push Buttons.....	1-7
	Real Time Clock.....	1-8
	Placement Options	1-8
	Desktop.....	1-8
	Rack Mounting	1-8
	Connecting the Hardware	1-8
	Wiring Requirements	1-8
	Connecting the Power	1-9
	Connecting to the Network.....	1-9
	Connecting to a Serial Device	1-10
	Connecting to the Console Port.....	1-10

Thank you for purchasing the Moxa DA-660 RISC-based ready-to-run embedded computer. The product's features include 8/16 RS-232/422/485 serial ports, and dual 10/100 Mbps Ethernet ports based on the Intel XScale IXP422 communication processor, which are packed into a standard 1U, 19-inch wide rack-mounted rugged enclosure. These features make DA-660 ideal for industrial environment applications, and let users easily install DA-660 on a standard 19-inch rack.

This manual introduces the features and functions of the hardware of the DA-660 series embedded computers. After a brief introduction of the hardware features, the manual focuses on installation and hardware configuration with device interfaces.

The following topics are covered in this chapter:

- ❑ **Overview**
 - Package Checklist
 - Product Features
 - Hardware Specifications
- ❑ **Hardware Introduction**
 - Appearance and Dimensions
 - Hardware Block Diagram
 - LED Indicators
 - Reset-type Buttons
 - LCM Screen
 - Push Buttons
 - Real Time Clock
- ❑ **Placement Options**
 - Desktop
 - Rack Mounting
- ❑ **Connecting the Hardware**
 - Wiring Requirements
 - Connecting the Power
 - Connecting to the Network
 - Connecting to a Serial Device
 - Connecting to the Console Port

Overview

DA-660 products are RISC-based ready-to-run embedded computers designed for industrial data applications. DA-660 products feature 8 or 16 RS-232/422/485 serial ports and dual Ethernet ports based on the Intel XScale IXP422 communication processor, all packed into a standard 1U, 19-inch wide rack-mounted rugged enclosure. This robust, rack-mountable design provides the hardened protection needed for industrial environment applications, and lets users easily install DA-660 on a standard 19-inch rack.

DA-660 products are not only suitable for the IT machine control room, but also for the critical assets found in the control and automation system of industrial plant floors, and even in the electric power utility substation. In order to satisfy diverse industrial applications, DA-660 products provide a wide range of power inputs from 100 to 240V, suitable for both AC and DC power lines. Due to the no hard disk, fan-less and energy efficient design, DA-660 products minimize heat generation, are able to operate 365/7/24 in heavy duty, harsh industrial environments to deliver strongly reliable, powerful computing, and provide the high performance expected of multifunctional controller usage.

Choose a pre-installed open standard Linux OS or the commonly used WinCE OS for your software program development. It is very easy to develop your control program with the built-in SDK and follow the common programming procedures used on a standard PC. All the software you develop for your own applications can be stored on the onboard Flash memory. Using DA-660 products, you can easily build a control system with distributed architecture on embedded technologies such as SCADA systems, plant floor automation, and power electricity monitoring applications.

Package Checklist

Before installing DA-660, verify that the package contains the following items:

- 1 DA-660 Embedded Computer
- 19-inch Rack-Mount Kit
- Quick Installation Guide
- Document & Software CD
- Ethernet Cable: RJ45 to RJ45 cross-over cable, 100 cm
- CBL-RJ45M9-150: RJ45 to DB9 male serial port cable, 150 cm
- CBL-RJ45F9-150: RJ45 to DB9 female console port cable, 150 cm
- Power Cord
- Product Warranty Booklet

NOTE: *Notify your sales representative if any of the above items is missing or damaged.*

Product Features

- Intel XScale IXP422 266 MHz Processor
- On-board 128 MB RAM, 32 MB Flash ROM
- 8/16 RS-232/422/485 serial ports
- Dual 10/100 Mbps Ethernet
- Standard 19-inch rack-mount installation, 1U height
- Wide range of power input voltages from 100 to 240V, both AC and DC
- LCM display and keypad for HMI
- Ready-to-run Linux/WinCE 5.0 .NET platform
- Robust, fanless design

Hardware Specifications

	DA-660-16	DA-660-8
CPU	Intel Xscale, IXP422 266 MHz	Intel Xscale, IXP422 266 MHz
RAM	128 MB	128 MB
Flash	32 MB	32 MB
LAN	Auto-sensing 10/100 Mbps × 2 with built-in 1.5 KV magnetic isolation protection RJ45 Connector	
Serial Port	RS-232/422/485 × 16 RJ45 Connector	RS-232/422/485 × 8 RJ45 Connector
Serial Protection	15 KV ESD for all signals	
Data Bits	5, 6, 7, 8	
Stop Bits	1, 1.5, 2	
Parity	none, even, odd, space, mark	
Flow Control	RTC/CTS, XON/XOFF, RS-485 ADDC™	
Speed	50 bps to 921.6 Kbps	
Serial Console	RS-232 × 1, RJ45 Connector	RS-232 × 1, RJ45 Connector
USB 2.0 Hosts	N/A	N/A
USB 1.1 Client	N/A	N/A
PCMCIA	N/A	N/A
Storage Expansion	N/A	N/A
LCM	2 × 16 Text Mode	2 × 16 Text Mode
Keypad Buttons	4	4
Watchdog Timer	Yes	Yes
Real Time Clock	Yes	Yes
Buzzer	Yes	Yes
Reset Button	Reset to Default × 1	Reset to Default × 1
Power Input	100 to 240 VAC/VDC	100 to 240 VAC/VDC
Power Consumption	15W	15W
Dimensions (W × D × H)	197 × 125 × 44 mm	197 × 125 × 44 mm
Weight	2.7 kg	2.5 kg
Operating temperature	-10 to 60°C (14 to 140°F), 5 to 95% RH	
Storage temperature	-20 to 70°C (-4 to 176°F), 5 to 95% RH	
Anti-Vibration	1 g @ IEC-68-2-6, sine wave (resonance search), 5-500 Hz, 1 Oct/min, 1 cycle, 13 mins 17 sec axis	

Regulatory Approvals	EMC: CE Class A, FCC Class A Safety: UL, cUL, TÜV
Warranty	5 years

Hardware Introduction

Appearance and Dimensions

Appearance

DA-660-16 Front View

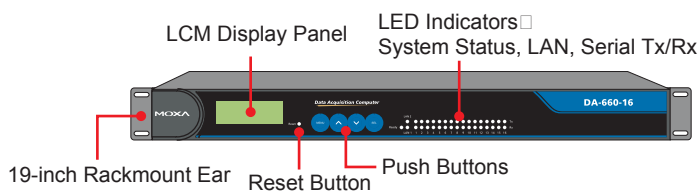

DA-660-16 Rear View

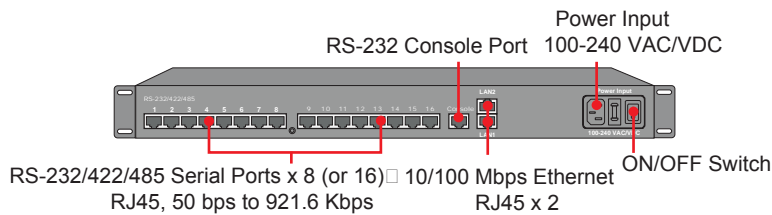

DA-660-8 Front View

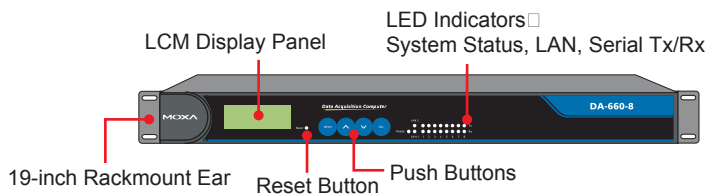

DA-660-8 Rear View

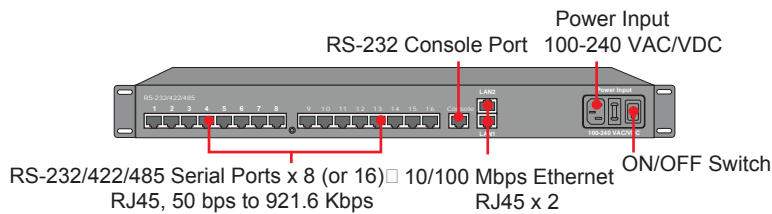

Dimensions

DA-660-8



DA-660-16

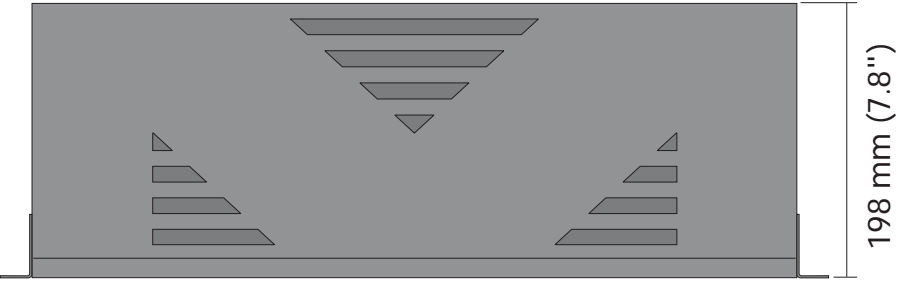

DA-660-8

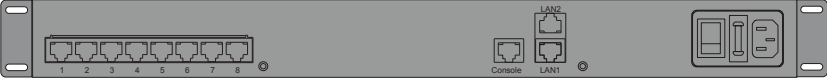

DA-660-16

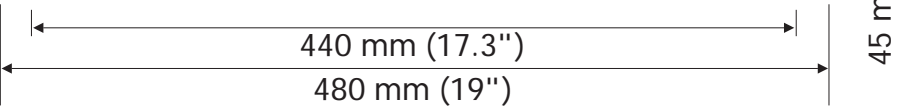
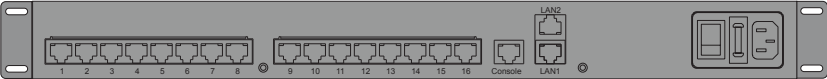

Hardware Block Diagram

The following block diagram shows the layout of the DA-660's internal components. The only difference between DA-660-16 and DA-660-8 is in the number of serial ports. DA-660-16 has 16 serial ports and DA-660-8 has 8 serial ports.

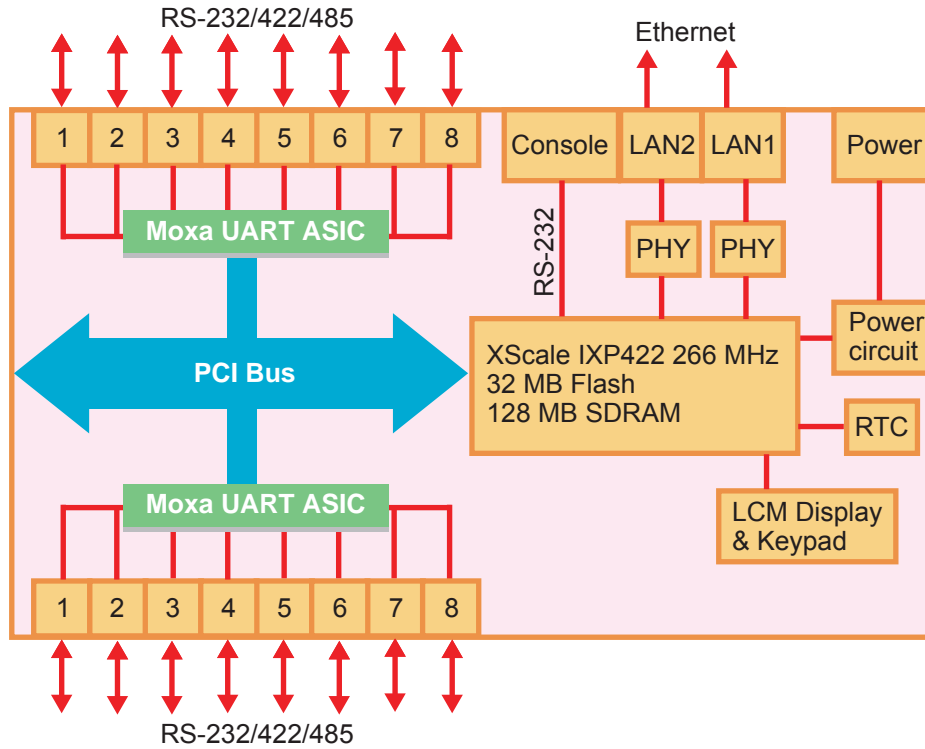

LED Indicators

LED indicators are located on the front panel of DA-660. DA-660-16 has 35 LED indicators and DA-660-8 has 19 LED indicators. The only difference between these two products lies in the serial port indicators. Refer to the following table for information about each LED.

LED Name	Color	Description
Ready	Red	Power is ON, and system is ready (after booting up)
LAN1, LAN2	Orange	10 Mbps Ethernet connection
	Green	100 Mbps Ethernet connection
P1-P16 (Tx)	Green	Serial port is transmitting TX data to the serial device.
	Off	Serial port is not transmitting TX data to the serial device.
P1-P16 (Rx)	Orange	Serial port is receiving RX data from the serial device.
	Off	Serial port is not receiving RX data from the serial device.

Reset-type Buttons

The DA-660 has a reset-type button. The button labeled Reset returns DA-660 to the factory default parameter configuration.

Reset Button

Press the **Reset** button on the front panel continuously for at least 5 seconds to load the **factory default configuration**. After the factory default configuration has been loaded, the system will reboot automatically. The **Ready** LED will blink on and off for the first 5 seconds, and then maintain a steady glow once the system has rebooted.

We recommend that you only use this function if the software is not working properly and you want to load factory default settings. To reset an embedded Linux system, always use the software reboot command `/>reboot` to protect the integrity of data being transmitted or processed. The **Reset** button is not designed to hard reboot the DA-660.



ATTENTION

Linux OS: DA-660-8/16-LX

Pressing the Reset button will only load the configuration file. All files in the /etc directory will revert to their factory defaults, and *all user data in the Flash ROM will be wiped out*.

WinCE OS: DA-660-8/16-CE

Pressing the Reset button will only load the default settings (i.e., the default registry values). All user data NOT in the Flash ROM will be wiped out.

LCM Screen

The DA-660 has an LCM screen on the front panel. The LCM can display 16 columns and 2 rows of text. After the DA-660 successfully boots up, the LCM will display the model name and firmware version as below:

D	A	-	6	6	0	-	1	6
V	E	R	.	1	.	0		

Push Buttons

There are four push buttons on the DA-660's front panel. These buttons are used to operate the LCM. Going from left to right, the buttons are:

Button	Action
MENU	Activates the main menu, or returns to main menu anytime.
⏪	Scrolls up through a list of items shown on the LCM screen's second line
⏩	Scrolls down through a list of items shown on the LCM screen's second line
SEL	Selects the option listed on the LCM screen.

Real Time Clock

The DA-660's real time clock is powered by a lithium battery. We strongly recommend that you do not replace the lithium battery without help from a qualified Moxa support engineer. If you need to change the battery, contact the Moxa RMA service team.



WARNING

There is a risk of explosion if the battery is replaced by an incorrect type.

Placement Options

Desktop

Place your DA-660 on a clean, flat, well-ventilated desktop. For better ventilation, attach the 4 pads from the desktop kit to the bottom of the unit, and leave some space between the DA-660 and other equipment. Do not place equipment or objects on top of the unit, as this might cause damage.

Rack Mounting

DA-660 is designed to be mounted on a standard 19-inch rack. Two L-shaped metal plates come standard with DA-660. Use the enclosed pair of L-shaped metal plates and screws to fasten your DA-660 to the rack cabinet. Two placement options are available. You can either lock the front or the rear panel of the DA-660 to the front of the rack. Each L-shaped plate has 6 holes, leaving two outer or inner holes open for your convenience.

Connecting the Hardware

This section describes how to connect DA-660 to serial devices. We cover **Wiring Requirements**, **Connecting the Power**, **Connecting to the Network**, **Connecting to a Serial Device**, and **Connecting to the Console Port**.

Wiring Requirements



ATTENTION

Safety First!

Be sure to disconnect the power cord before installing and/or wiring your DA-660.

Wiring Caution!

Calculate the maximum possible current in each power wire and common wire. Observe all electrical codes dictating the maximum current allowable for each wire size.

If the current goes above the maximum ratings, the wiring could overheat, causing serious damage to your equipment.

Temperature Caution!

Be careful when handling DA-660. When plugged in, DA-660's internal components generate

heat, and consequently the outer casing may feel hot to the touch.

You should also observe the following common wiring rules:

- Use separate paths to route wiring for power and devices. If power wiring and device wiring paths must cross, make sure the wires are perpendicular at the intersection point.

NOTE: Do not run signal or communication wiring and power wiring in the same wire conduit. To avoid interference, wires with different signal characteristics should be routed separately.

- You can use the type of signal transmitted through a wire to determine which wires should be kept separate. The rule of thumb is that wiring that shares similar electrical characteristics can be bundled together.
- Keep input wiring and output wiring separate.
- Where necessary, it is strongly advised that you label wiring to all devices in the system.

Connecting the Power

To power on the DA-660 connect the power line to the DA-660's AC/DC power connector (located on the right side of the rear panel) using the power cord that is shipped with the product. Then, turn on the power switch. The device takes about 30 seconds to boot up. Once the device is ready, the Ready LED on the front panel will light up, and the DA-660 model name and firmware version will appear on the LCM display.

Connecting to the Network

Connect one end of the Ethernet cable to one of the DA-660's 10/100M Ethernet ports (8-pin RJ45) and the other end of the cable to the Ethernet network. If the cable is properly connected, the DA-660 will indicate a valid connection to the Ethernet in the following ways:

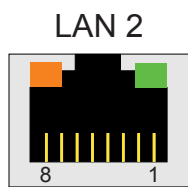

The top right and lower right corner LED indicator glows a solid green color when the cable is properly connected to a 100 Mbps Ethernet network. The LED will flash on and off when Ethernet packets are being transmitted or received.

Pin	Signal
1	ETx+
2	ETx-
3	ERx+
4	---

The top left and lower left corner LED indicator glows a solid orange color when the cable is properly connected to a 10 Mbps Ethernet network. The LED will flash on and off when Ethernet packets are being transmitted or received.

5	---
6	ERx-
7	---
8	---

Connecting to a Serial Device

Use properly wired serial cables to connect the DA-660 to serial devices. The DA-660's serial ports (P1 to P16) use 8-pin RJ45 connectors. The ports can be configured by software for RS-232, RS-422, or 2-wire RS-485. The precise pin assignments are shown in the following table:

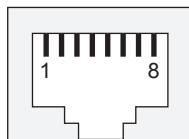

Pin	RS-232	RS-422	RS-485
1	DSR	---	---
2	RTS	TXD+	---
3	GND	GND	GND
4	TXD	TXD-	---
5	RXD	RXD+	Data+
6	DCD	RXD-	Data-
7	CTS	---	---
8	DTR	---	---

Connecting to the Console Port

The console port is an 8-pin RJ45 RS-232 port. The port can be used to connect to the console utility from a remote console via a V90 or GPRS modem with PPP protocol. The pin definition is the same as for the serial ports (P1 to P16). For normal data acquisition applications, you should connect to DA-660's serial ports (P1 to P16) via a V90 or GPRS modem. If you would like to use the console port for normal data acquisition applications, you can set the console port to start up via PPP protocol.