

# DA-682 Series Embedded Computer Hardware User's Manual

---

Third Edition, January 2010

[www.moxa.com/product](http://www.moxa.com/product)

**MOXA**®

© 2010 Moxa Inc. All rights reserved.  
Reproduction without permission is prohibited.

# DA-682 Series Embedded Computer Hardware User's Manual

Any software described in this manual is furnished under a license agreement and may be used only in accordance with the terms of that agreement.

## Copyright Notice

Copyright © 2010 Moxa Inc.  
All rights reserved.  
Reproduction without permission is prohibited.

## Trademarks

MOXA is a registered trademark of Moxa Inc.  
All other trademarks or registered marks in this manual belong to their respective manufacturers.

## Disclaimer

Information in this document is subject to change without notice and does not represent a commitment on the part of Moxa.

Moxa provides this document “as is,” without warranty of any kind, either expressed or implied, including, but not limited to, its particular purpose. Moxa reserves the right to make improvements and/or changes to this manual, or to the products and/or the programs described in this manual, at any time.

Information provided in this manual is intended to be accurate and reliable. However, Moxa assumes no responsibility for its use, or for any infringements on the rights of third parties that may result from its use.

This product might include unintentional technical or typographical errors. Changes are periodically made to the information herein to correct such errors, and these changes are incorporated into new editions of the publication.

## Technical Support Contact Information

**[www.moxa.com/support](http://www.moxa.com/support)**

### Moxa Americas:

Toll-free: 1-888-669-2872  
Tel: +1-714-528-6777  
Fax: +1-714-528-6778

### Moxa China (Shanghai office):

Toll-free: 800-820-5036  
Tel: +86-21-5258-9955  
Fax: +86-10-6872-3958

### Moxa Europe:

Tel: +49-89-3 70 03 99-0  
Fax: +49-89-3 70 03 99-99

### Moxa Asia-Pacific:

Tel: +886-2-8919-1230  
Fax: +886-2-8919-1231

# Table of Contents

<b>Chapter 1</b>	<b>Introduction .....</b>	<b>1-1</b>
	Overview.....	1-2
	Model Descriptions and Package Checklist.....	1-2
	Appearance .....	1-3
	Dimensions .....	1-4
	Features.....	1-4
	Hardware Block Diagram .....	1-5
	DA-682 Basic System .....	1-5
	DA-SP08-I-DB Serial Port Expansion Module.....	1-6
	DA-LN04-RJ LAN Port Expansion Module .....	1-6
	Hardware Specifications .....	1-7
	Basic Systems.....	1-7
	Serial Port Expansion Modules .....	1-9
	LAN Port Expansion Module.....	1-10
	Switch Port Expansion Module .....	1-10
	Universal PCI Slot.....	1-10
	Non-standard Baudrates.....	1-10
<b>Chapter 2</b>	<b>Hardware Installation.....</b>	<b>2-1</b>
	Placement Options .....	2-2
	Desktop.....	2-2
	Rack mounting .....	2-2
	Wiring Requirements .....	2-5
	Connecting the Power .....	2-6
	Reset Button.....	2-7
	Front Panel LED .....	2-7
	Connecting to a Display .....	2-8
	Connecting a PS/2 Keyboard and Mouse.....	2-8
	Connecting USB Devices .....	2-9
	Gigabit LAN Ports .....	2-10
	Upgrading the Memory Module .....	2-11
	Installing a CompactFlash Card.....	2-14
	Installing a SATA Hard Disk.....	2-17
	Inserting and Removing Expansion Modules .....	2-19
	DA-SP08-I-DB/DA-SP08-DB Serial Expansion Modules .....	2-20
	DA-SP08-I-TB Serial Expansion Module .....	2-21
	DA-LN04-RJ LAN Expansion Module .....	2-21
<b>Chapter 3</b>	<b>BIOS Setup .....</b>	<b>3-1</b>
	Entering the BIOS Setup Utility .....	3-2
	Modifying the BIOS Main Settings .....	3-2
	Basic Configuration.....	3-2
	System Security.....	3-3
	Advanced Settings .....	3-4
	Hard Disk Boot Priority.....	3-4
	Advanced BIOS Features .....	3-5
	CPU Features.....	3-5
	Advanced Chipset Settings.....	3-7
	PnP/PCI Configurations .....	3-8
	Frequency/Voltage Control .....	3-9

Peripherals .....	3-9
OnChip IDE Device .....	3-10
Onboard Device.....	3-11
Onboard GigaLan Control.....	3-12
Onboard I/O Chip Setup.....	3-12
Power .....	3-13
Wake Up Control.....	3-14
Hardware Monitor.....	3-15
Load Defaults.....	3-15
Exiting the BIOS Setup.....	3-16
Upgrading the BIOS .....	3-17

**Appendix A Safety Installation Instructions..... A-1**

Thank you for purchasing a Moxa DA-682 Series X86-based industrial ready-to-run embedded computer.

The DA-682 computers come pre-installed with one of three embedded operating systems:

- DA-682-CE: Windows CE 6.0
- DA-682-LX: Linux
- DA-682-XPE: Windows XP Embedded

This manual introduces the hardware installation, connector interfaces and BIOS setup of the DA-682. For software configuration and management, please refer to the user's manual for your operating system.

This chapter covers the following topics:

- Overview**
- Model Descriptions and Package Checklist**
- Appearance**
- Dimensions**
- Features**
- Hardware Block Diagram**
  - DA-682 Basic System
  - DA-SP08-I-DB Serial Port Expansion Module
  - DA-LN04-RJ LAN Port Expansion Module
- Hardware Specifications**
  - Basic System
  - Serial Port Expansion Module
  - Switch Port Expansion Module
  - LAN Port Expansion Module
- Non-standard Baudrates**

## Overview

The Moxa DA-682 Series of X86-based rackmount embedded computers are designed for industrial data acquisition applications. The state-of-art 2 expansion module design provides greater flexibility by allowing combinations of up to 16 RS-232/422/485 serial ports or up to 4+8 Ethernet ports. This friendly design gives users the advantage of being able to swap out modules quickly and easily. Additional expansion modules will be available soon to provide even greater flexibility.

The DA-682's main operating system is based on the Intel Celeron M processor and 915GME chipset, which supports standard X86 VGA, USB, PS/2 keyboard/mouse, 4 Gigabit LAN ports, and IDE/SATA disk interface. In addition, the DA-682 has a CompactFlash socket and comes with Linux, WinCE 6.0, Windows XP Embedded pre-installed. Programmers will find the full-function development kit a great benefit for developing software and building reliable communication applications.

The housing is a standard 2U, 19-inch wide rack-mounted rugged enclosure. This robust, rack-mountable design provides the hardened protection needed for industrial environment applications.

## Model Descriptions and Package Checklist

The DA-682 Series includes the following models:

- **DA-682-CE**  
DA-682 basic system, VGA, 4 Gigabit LANs, USB x 4, CompactFlash socket, 256 MB system memory, 256 MB WinCE 6.0 pre-installed flash disk module
- **DA-682-LX**  
DA-682 basic system, VGA, 4 Gigabit LANs, USB x 4, CompactFlash socket, 512 MB system memory, 1 GB Linux pre-installed flash disk module
- **DA-682-XPE**  
DA-682 basic system, VGA, 4 Gigabit LANs, USB x 4, CompactFlash socket, 512 MB system memory, 1 GB Windows XPE pre-installed flash disk module.

Each model is shipped with following standard items:

### ***DA-682 Basic System:***

- Quick Installation Guide
- Document & Software CD
- Cross-over Ethernet cable
- AC Power Cord
- Product Warranty Statement

### ***Optional Expansion Modules:***

DA-SP08-I-DB: 8-port RS-232/422/485 serial port module with isolation protection, DB9 connectors

DA-SP08-DB: 8-port RS-232/422/485 serial port module, DB9 connectors

DA-SP08-I-TB: 8-port RS-232/422/485 serial port module with isolation protection, terminal block connector

DA-LN04-RJ: 4-port 10/100 Mbps LAN module.

DA-UPCI-DK: 5V standard PCI extension kit



**ATTENTION**

Additional expansion modules are currently under development.

## Appearance



**Front View**

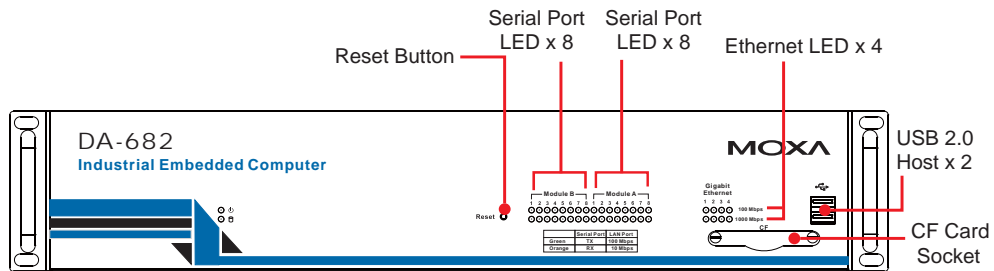

**Rear View**

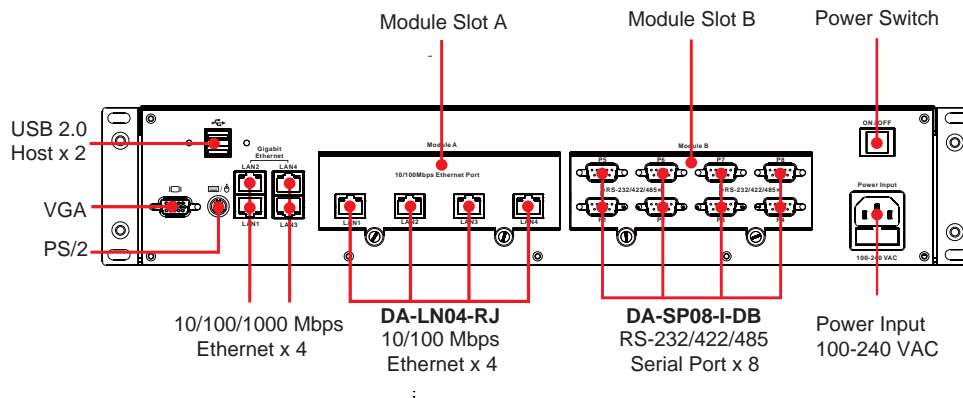

**ATTENTION**

Expansion modules can be installed in either slot A or slot B. In the above figures we shown an example of LAN module DA-LN04-RJ installed in slot A and serial module DA-SP08-I-DB installed in slot B.

## Dimensions

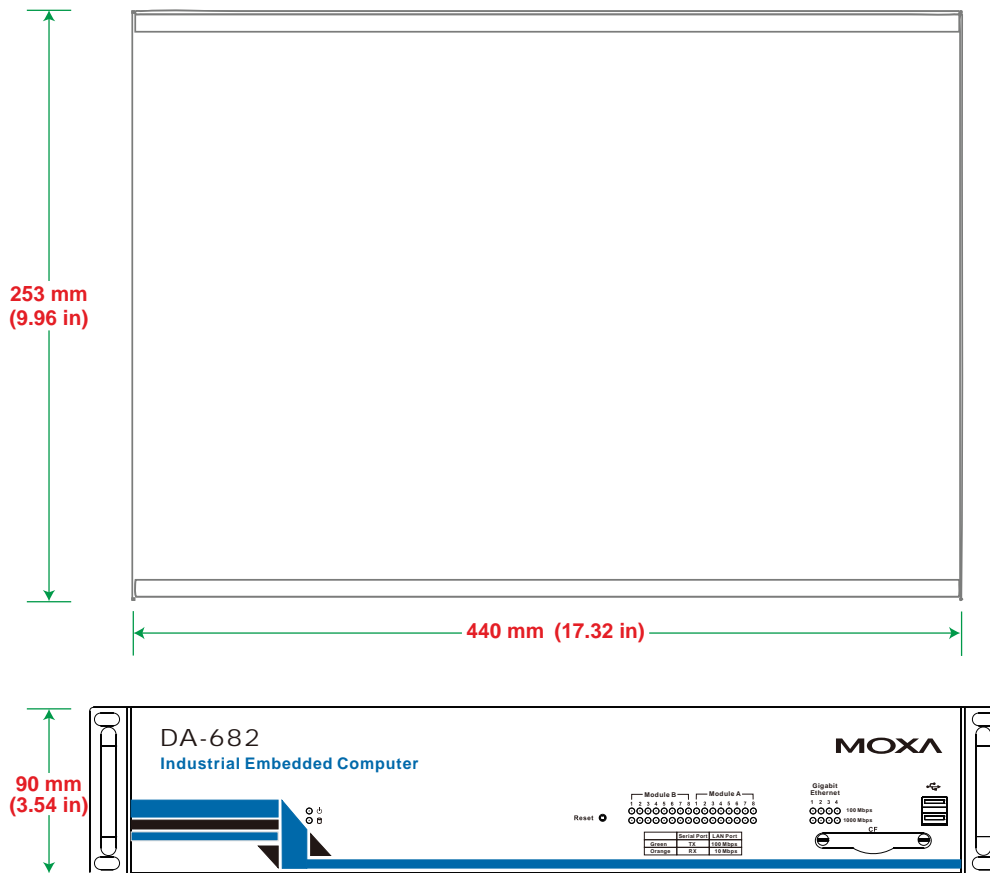

## Features

The DA-682 Basic System has the following features:

- Intel Celeron M 1GHz processor with 400/533 MHz FSB
- Intel 915GME + ICH6M chipset
- 200-pin DDR2 SODIMM socket x1, supporting DDR2 400/533 up to 1 GB
- 4 Gigabit Ethernet ports for network redundancy
- 1 CompactFlash socket
- 1 SATA connector for storage expansion
- USB 2.0 ports for high speed peripherals
- 2 expansion module slots for I/O expansion
- 19-inch rackmount, 2U height form factor
- Fanless design
- 100/240 VAC/VDC power inputs
- Ready-to-run Linux, WinCE 6.0, or Windows XP Embedded platform pre-installed on the flash disk module



Features supported by expansion modules:

- 8 or 16 software selectable RS-232/422/485 serial ports, with or without isolation protection
- Serial port baudrates from 50 to 921.6 Kbps, with support for most non-standard baudrates in this range
- Additional 4 or 8 10/100 Mbps Ethernet ports



**ATTENTION**

Refer to the “Non-standard Baudrates” section for instructions on how to calculate which baudrates are supported.

## Hardware Block Diagram

### DA-682 Basic System

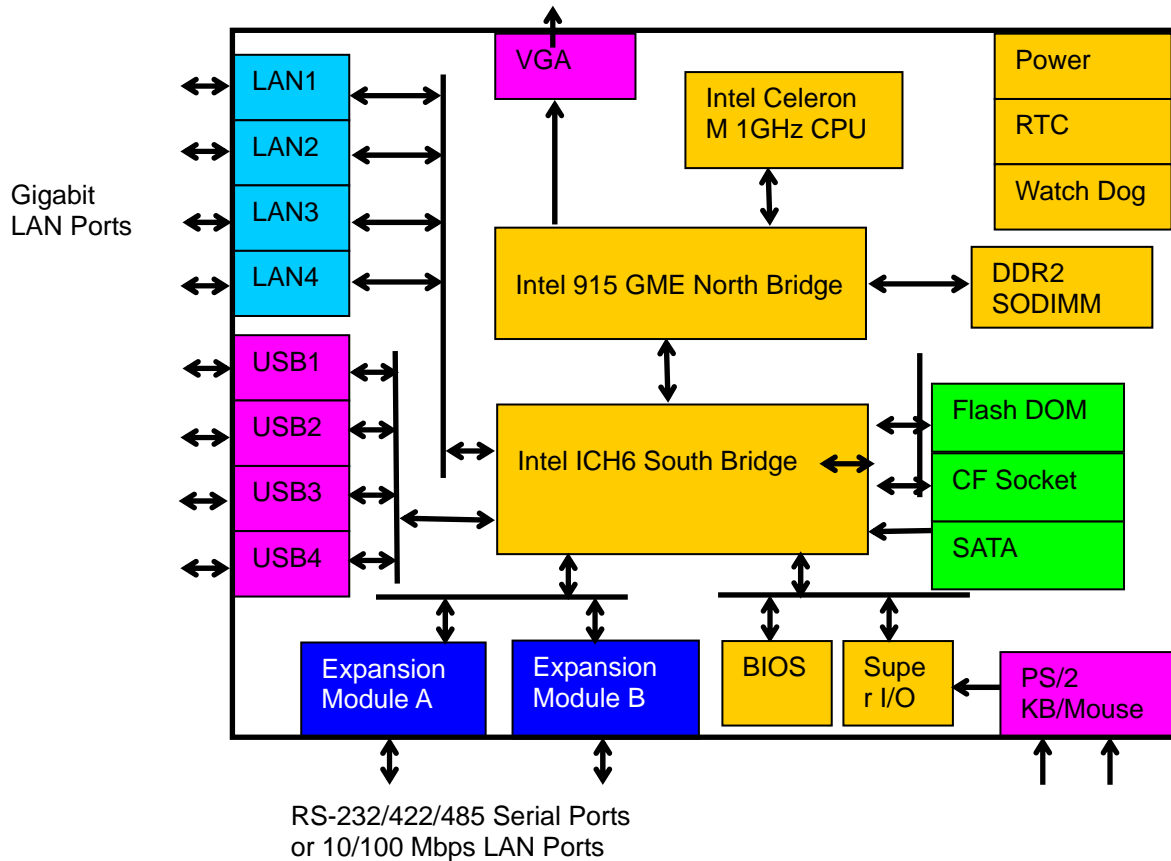

### DA-SP08-I-DB Serial Port Expansion Module

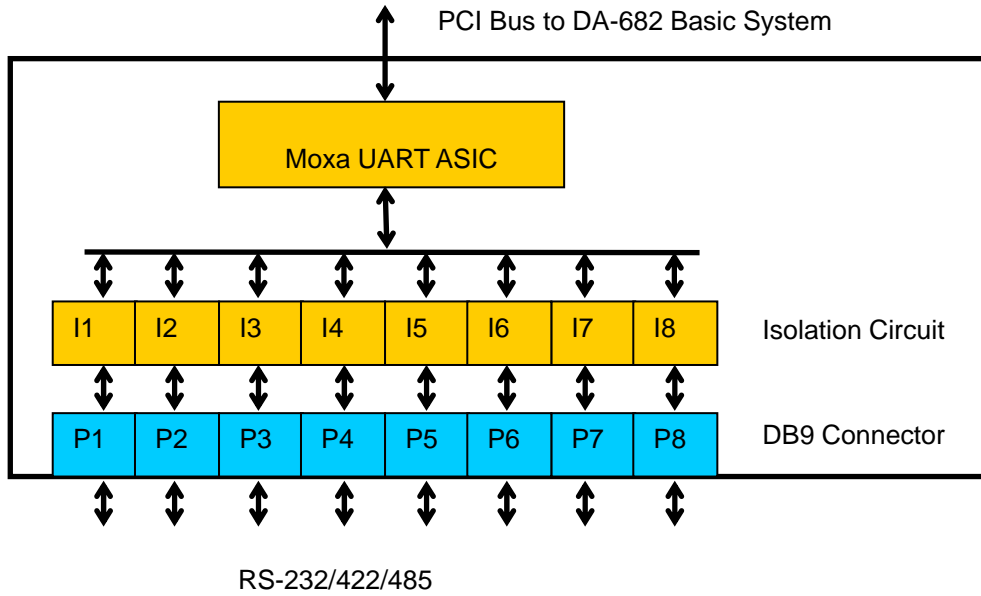

### DA-LN04-RJ LAN Port Expansion Module

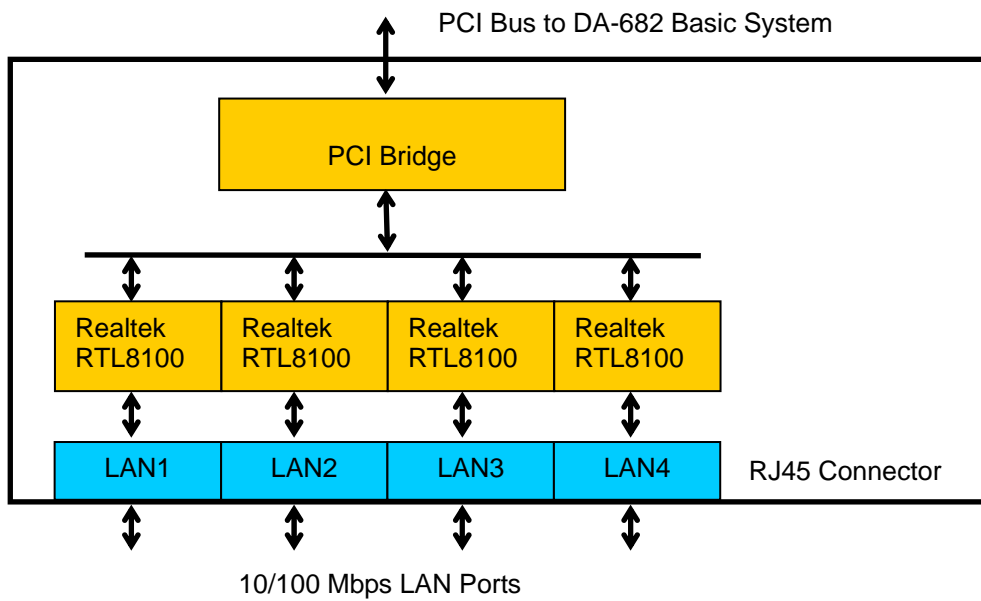

## Hardware Specifications

DA-682 series embedded computers support peripheral expansion through two expansion slots located on the DA-682 Basic System.

### Basic Systems

	DA-682-CE	DA-682-LX	DA-682-XPE
<b>Computer</b>			
CPU	Intel Celeron M 1 GHz processor		
OS (pre-installed)	WinCE 6.0	Linux 2.6	Windows XP Embedded SP2
System Chipset	Intel 915GME + ICH6M chipset		
FSB	400/533 MHz		
Expansion Bus	Two PCI expansion slots (one slot reserved for additional peripherals)		
BIOS	4 mega-bit Flash BIOS, PCI Plug & Play, ACPI function support		
System Memory	1 x 200-pin DDR2 SODIMM socket supporting DDR2 400/533 (256 MB max.)	1 x 200-pin DDR2 SODIMM socket supporting DDR2 400/533 (1 GB max.)	1 x 200-pin DDR2 SODIMM socket supporting DDR2 400/533 (512 MB max.)
CompactFlash	Socket available for storage expansion with DMA mode support		
<b>Other Peripherals</b>			
USB	USB 2.0 compliant hosts x 4, Type A connector, supports system boot up		
KB/MS	1 PS/2 interface, support standard PS/2 keyboard and PS/2 mouse via Y-type cable (Optional)		
<b>Display</b>			
Graphics Controller	Integrated graphics with built-in Intel 915GME, and built-in Intel extreme Graphics 2 technology		
Display Memory	Dynamic video memory (shares up to 32 MB of system memory)		
Display Interface	CRT Interface for VGA output (DB15 female connector)		
Resolution	CRT display mode with pixel resolution up to 2548 x 1536 at 75Hz		
<b>Ethernet Interface</b>			
LAN	Auto-sensing 10/100/1000 Mbps Gigabit Ethernet x 4, using Realtek RTL8110SC Controller		
Magnetic Isolation Protection	1.5 KV built-in		
<b>Serial Interface</b>			
Number of Ports	8		
Serial Standards	RS-232/422/485		
Connectors	DB9 male		
ESD protection	15 KV for all signals		
Optical Isolation Protection	2 KV		

<b>Serial Communication Parameters</b>	
Data Bits	5, 6, 7, 8
Stop Bits	1, 1.5, 2
Parity	None, Even, Odd, Space, Mark
Flow Control	RTS/CTS, XON/XOFF, ADDC™ (automatic data direction control) for RS-485
Baudrate	50 bps to 921.6 Kbps (non-standard baudrates supported; see user's manual for details)
<b>Serial Signals</b>	
RS-232	TxD, RxD, DTR, DSR, RTS, CTS, DCD, GND
RS-422	TxD+, TxD-, RxD+, RxD-, GND
RS-485-4w	TxD+, TxD-, RxD+, RxD-, GND
RS-485-2w	Data+, Data-, GND
<b>LEDs</b>	
Sytem	Ready x 1, Storage x 1
LAN	Act/Link x 8, 10/100M mode x 8
Serial	TX/RX x 8
<b>Physical Characteristics</b>	
Enclosure	SECC sheet metal (1 mm)
Weight	2.94 kg
Dimensions	440 x 310 x 90 mm (17.32 x 12.2 x 3.54 in)
Mounting	Standard 19-inch rackmount
<b>Switches and Buttons</b>	
Power Switch	on/off (on rear panel)
Reset Button	To reset system hardware (on front panel)
<b>Environmental Limits</b>	
Operating Temperature	-10 to 60°C (14 to 140°F)
Operating Humidity	5 to 95% RH
Storage Temperature	Standard Models: -20 to 80°C (-4 to 176°F)
Anti-Vibration	2 g rms @ IEC-68-2-34, random wave, 5-500 Hz, 1 hr/axis
Anti-Shock	20 g @ IEC-68-2-27, half sine wave, 11 ms
<b>Power Requirements</b>	
Input Voltage	100 to 240 VAC/VDC auto-ranging (47 to 63 Hz for AC input)
Power Consumption	50W
Input Rating	100-240VAC, 47-63Hz, 1.0A-0.5A
<b>Regulatory Approvals</b>	
EMC	CE (EN55022 Class A, EN61000-3-2 Class A, EN61000-3-3, EN55024), FCC (Part 15 Subpart B, CISPR 22 Class A), CCC (GB9254, GB 17625.1)
Safety	UL/cUL (UL60950-1, CSA C22.2 No. 60950-1-03), LVD (EN60950-1), CCC (GB4943)

<b>Reliability</b>	
Alert Tools	Built-in buzzer and RTC (real-time clock) with battery lithium backup
Automatic Reboot Trigger	Built-in WDT (watchdog timer) supporting 1-255 level time interval system reset, software programmable
<b>Warranty</b>	
Warranty Period	3 years
Details	See <a href="http://www.moxa.com/warranty">www.moxa.com/warranty</a>

## Serial Port Expansion Modules

	<b>DA-SP08-I-DB</b>	<b>DA-SP08-DB</b>	<b>DA-SP08-I-TB</b>	<b>DA-SP38-I-TB</b>
<b>Serial Interface</b>				
Number of Ports	RS-232/422/485 x 8			RS-422/485 x 8
Serial Standards	RS-232/422/485, software-selectable			RS-422/485
Connector	DB9 male	DB9 male	5-pin terminal block	
Protection	15 KV ESD and 2 KV isolation protection for all signals	15 KV ESD protection for all signals	15 KV ESD and 2 KV isolation protection for all signals	15 KV ESD and 2 KV isolation protection for all signals
<b>Serial Signals</b>				
RS-232	TxD, RxD, DTR, DSR, RTS, CTS, DCD, GND			N/A
RS-422	TxD+, TxD-, RxD+, RxD-, GND			
RS-485 4-wire	TxD+, TxD-, RxD+, RxD-, GND			
RS-485 2-wire	Data+, Data-, GND			
Data bits	5, 6, 7, 8			
Stop bits	1, 1.5, 2			
Parity	None, Even, Odd, Space, Mark			
Flow Control	RTS/CTS, XON/XOFF, RS-485 ADDC™			



### ATTENTION

Refer to the “Non-standard Baudrates” section for instructions on how to calculate which baudrates are supported.

## LAN Port Expansion Module

	<b>DA-LN04-RJ</b>
LAN Port	Auto-sensing 10/100 Mbps x 4
Connector	RJ45 connector
Protection	1.5 KV magnetic isolation protection

## Switch Port Expansion Module

	<b>DA-SW08-RJ</b>
Switch Port	Auto-sensing unmanaged 10/100 Mbps x 8
Connector	RJ45 connector
Protection	1.5 KV magnetic isolation protection

## Universal PCI Slot

	<b>DA-UPCI-DK</b>
Fit-in System	DA-682 Series
PCI Slot	1
Interface Bus	32-bit Universal PCI (3.3V and 5V)

## Non-standard Baudrates

Moxa's UART ASIC, which is used for both the DA-SP08-I-DB and DA-SP08-I-TB serial expansion modules, supports most non-standard baudrates in the range 50 bps to 921.6 Kbps. In fact, supported baudrates are much denser towards the lower values. For example, no baudrates are supported between the integers 5320 and 5323, but 49 baudrates are supported between the integers 387 and 388. Of course this is the way it should be, since serial devices that require using non-standard baudrates generally use slower baudrates.

Before using a serial device that requires using a non-standard baudrate, you must first check that the DA-682 supports a baudrate within the tolerance specified by the serial device manufacturer.

Use the following formula to calculate which baudrates are supported by the DA-283:

$$(A) \text{ Baudrate} = 921600/(N+M/8) \text{ bps, for } N = 1, 2, \dots, 18431, M = 0, 1, 2, \dots, 7$$

or

$$(B) \text{ Baudrate} = 8 \times 921600/K \text{ bps, for } K = 8, 9, \dots, 147456$$

If you are a programmer and you need to write a driver for your serial device, then you may need to use formula A. If you have a serial device that requires using a non-standard baudrate, then you can use formula B to determine if the DA-682 supports a baudrate within the tolerance specified by the serial device manufacturer.

**Example:** Your serial device requires using a baudrate of 5340 bps and has a tolerance of 2 bps. Can the DA-682 be used with this device?

**Solution:** Set formula B to the desired baudrate and then solve for K.

$$8 \times 921600/K = 5338 \quad \implies \quad K = 1367.703259\dots$$

This shows that the supported baudrate closest to 5340 comes from setting K=1367 or K=1368.

K=1368 ==> Baudrate1 = 5336.842105...

K=1367 ==> Baudrate2 = 5340.746159...

Since  $5338 - \text{Baudrate1} < 2$ , we can see that the DA-682 supports the serial device.

Note that we can use formula A to generate the so-called "standard" baudrates, which come from setting M=0, and setting N equal to certain integers.

Standard Baudrates						
Baudrate	N	M		Baudrate	N	M
921600	1	0		4800	192	0
460800	2	0		2400	384	0
230400	4	0		1800	512	0
115200	8	0		1200	768	0
57600	16	0		600	1536	0
38400	24	0		300	3072	0
19200	48	0		150	6144	0
9600	96	0		75	12288	0
7200	128	0		50	18432	0



**WARNING**

Communication between a serial device and a Moxa UART port may not work correctly if the serial device uses a baudrate that is not within the correct tolerance of a baudrate calculated from either formula A or formula B.

# 2

## Hardware Installation

---

The DA-682 Series of embedded computers are compact and rugged, making them suitable for industrial applications. The LED indicators allow users to monitor performance and identify trouble spots quickly, and multiple ports are provided for connecting a variety of different devices. The DA-682 embedded computers come with a reliable and stable hardware platform that lets you devote the bulk of your time to application development. This chapter describes hardware installation and connector interfaces of the DA-682 embedded computers.

This chapter covers the following topics:

- Placement Options**
  - Desktop
  - Rack mounting
- Wiring Requirements**
- Connecting the Power**
- Reset Button**
- Front Panel LED**
- Connecting to a Display**
- Connecting a PS/2 Keyboard and Mouse**
- Connecting USB Devices**
- Gigabit LAN Ports**
- Upgrading the Memory Module**
- Installing a CompactFlash Card**
- Installing a SATA Hard Disk**
- Error! Reference source not found.
- DA-SP08-I-DB/DA-SP08-DB Serial Expansion Modules**
- DA-SP08-I-TB Serial Expansion Module**
- DA-LN04-RJ LAN Expansion Module**



## Placement Options

### Desktop

Place your DA-682 on a clean, flat, well-ventilated desktop. For better ventilation, leave some space between the DA-682 and other equipment. Do not place equipment or objects on top of the DA-682, as this might damage the computer's internal components.

### Rack mounting

The DA-682 has rackmount supports for installing the embedded computer on a standard rack.



#### ATTENTIONS

1. For maximum safety, at least two persons should work together to lift, place, and attach the embedded computer to the rack.
2. Before you lift or move the embedded computer, make sure that the embedded computer is turned off and the power to the rack system is turned off.

Four rackmount screws are required to attach the DA-682 to a standard rack.

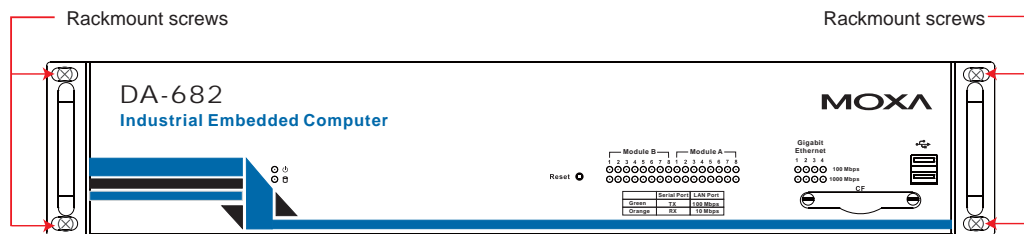

Follow these steps to install the DA-682 on a rack.

#### Step 1: Installing the rackmount supports.

Take the rackmount supports out of the packages. There are two packages, each of which contains 1 rackmount support, 1 rackmount hanger, 2 FMSM5X10 screws, and 6 FMSM4X6 screws.



**Step 2: Installing rackmount hanger to the support.**

Use 2 FMSM5X10 screws to attach the rackmount hanger to the ear. Repeat this procedure for the additional support and hanger.



**Step 3: Installing the rackmount ears to the DA-682.**

Use 6 FMSM4X6 screws to attach one rackmount support to one side of the DA-682. Repeat this procedure for the additional support+hanger.

**Step 4: Installing the DA-682 to a rack.**

Gently slide the DA-682 onto the rack, and then use screws provided by the rack supplier to fix the rackmount support to the rail.



Note that four screws are required to attach the DA-682 to the rack. Use two screws on the left side and two screws on the right side.



As a final check, make sure that the four screws are firmly attached to the rack.



## Wiring Requirements

The following common safety precautions should be observed before installing any electronic device:

- Use separate paths to route wiring for power and devices. If power wiring and device wiring paths must cross, make sure the wires are perpendicular at the intersection point.
- You can use the type of signal transmitted through a wire to determine which wires should be kept separate. The rule of thumb is that wiring that shares similar electrical characteristics can be bundled together.
- Keep input wiring and output wiring separate.
- When necessary, it is strongly advised that you label wiring to all devices in the system.



### ATTENTION

Do not run signal or communication wiring and power wiring in the same wire conduit. To avoid interference, wires with different signal characteristics should be routed separately.



**ATTENTION**

**Safety First!**

Be sure to disconnect the power cord before installing and/or wiring your device.

**Electrical Current Caution!**

Calculate the maximum possible current in each power wire and common wire. Observe all electrical codes dictating the maximum current allowable for each wire size.

If the current goes above the maximum ratings, the wiring could overheat, causing serious damage to your equipment.

**Temperature Caution!**

Be careful when handling the unit. When the unit is plugged in, the internal components generate heat, and consequently the outer casing may feel hot to the touch.

## Connecting the Power

To power on the DA-682 embedded computer, connect the power line to the DA-682's AC power connector (located on the right side of the rear panel) using the power cord shipped with the product, and then turn on the power switch. If the power is properly supplied, the Power LED will light up first, and then the Storage LED will start blinking when the Flash Disk Module is accessed during boot up. It takes about 30 to 60 seconds for the operating system to boot up.

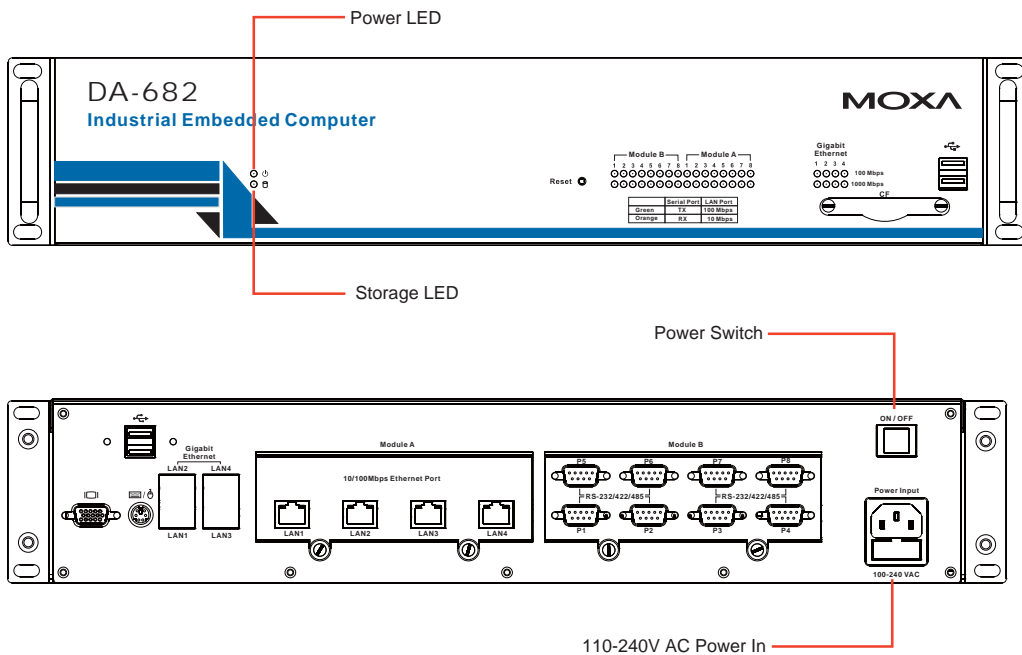

## Reset Button

Pressing the Reset button initiates a hardware warm reboot. The button plays the same role as a desktop PC's reset button. After pressing the reset button, the system will reboot automatically. During normal use, you should NOT use the Reset Button. You should only use this button if the software is not working properly. To protect the integrity of data being transmitted or processed, you should always reset the system from the operating system with the software reboot function.

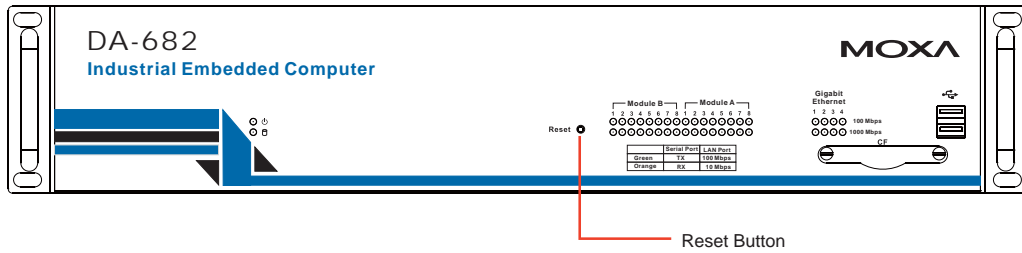

## Front Panel LED

There are 40 LED indicators on the front panel. Information about each LED is given in the following table.

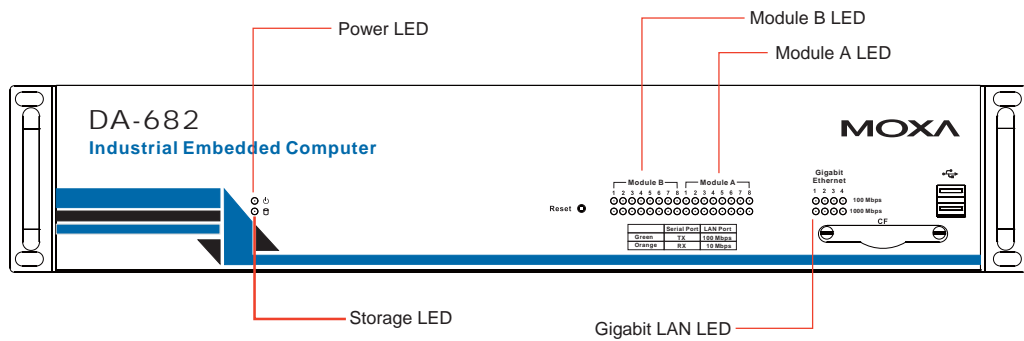

LED	Color	Description
Power	Green	Power is on
	Off	No power input or power error exists
Storage	Orange/Blinking	Data is being written to or to read from the storage unit
	Off	Storage unit is idle
Gigabit LAN LEDs 1-4	Green	100 Mbps Ethernet mode
	Orange	1000 Mbps (Gigabit) Ethernet mode
	Off	No operation or 10 Mbps Ethernet mode
Module A LEDs 1-8	Green	100 Mbps Ethernet mode or TX signal of serial port is active.
	Orange	10 Mbps Ethernet mode or RX signal of serial port is active.
	Off	No operation
Module B LED 1-8	Green	100 Mbps Ethernet mode or TX signal of serial port is active.
	Orange	10 Mbps Ethernet mode or RX signal of serial port is active.
	Off	No operation

## Connecting to a Display

Your DA-682 embedded computer comes with a D-Sub 15-pin female connector to connect to the VGA monitor. Be sure to remove the power before you connect or disconnect the monitor cable.

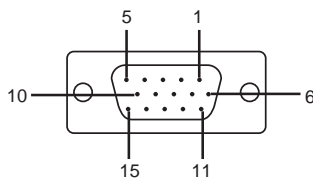
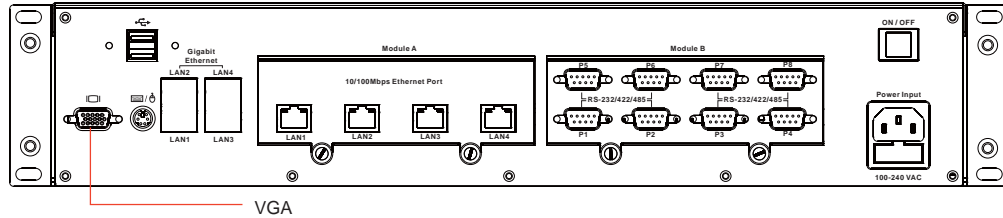

Pin No.	Signal Definition
1	RED
2	GREEN
3	BLUE
4	---
5	GND
6	CRT_DETECT#
7	GND
8	GND
9	+5V
10	GND
11	---
12	DDC_DATA
13	HSYNC
14	VSYSNC
15	---

## Connecting a PS/2 Keyboard and Mouse

Your DA-682 embedded computer comes with a PS/2 mini-DIN connector to connect to a PS/2 keyboard and PS/2 mouse. This 6-pin mini-DIN connector has the pin assignments shown below.

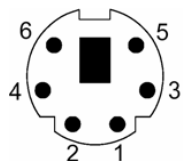
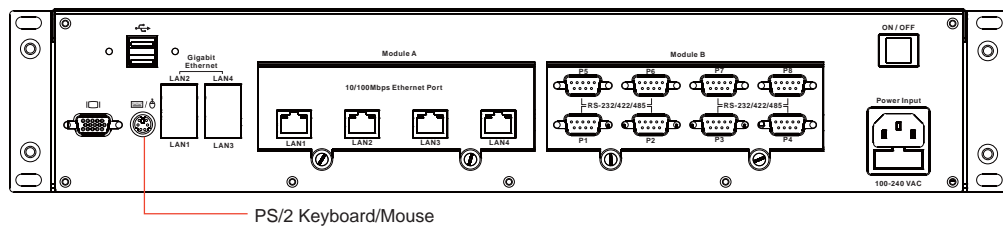

Pin No.	Signal Definition
1	PS/2 Keyboard Data
2	PS/2 Mouse Data
3	GND
4	VCC
5	PS/2 Keyboard Clock
6	PS/2 Mouse Clock

Use the Y-type cable to convert the mini-DIN connector into two 6-pin mini-DIN connectors to connect both a PS/2 keyboard and PS/2 mouse at the same time.

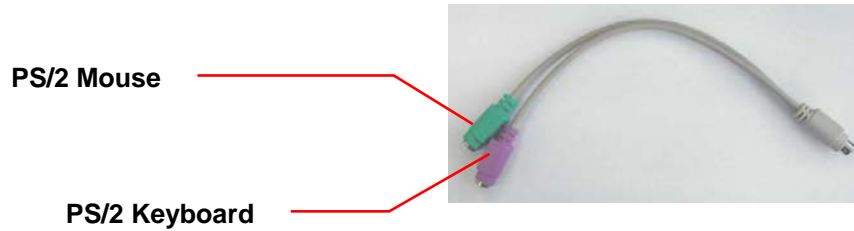

### Connecting USB Devices

The DA-682 embedded computer has four USB 2.0 ports, with two ports on the front panel and the other two on the rear panel. All of the ports are UHCI, Rev 2.0 compliant and support Plug & Play and hot swapping. These ports can be used to connect USB devices, such as a keyboard, mouse, USB flash disk, and USB CD-ROM. In addition, both USB ports support system boot up, which can be activated by modifying the BIOS settings. The chapter “BIOS Setup” describes the configuration process in detail.

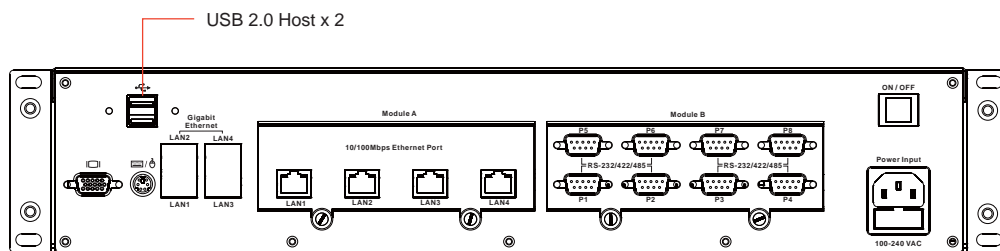
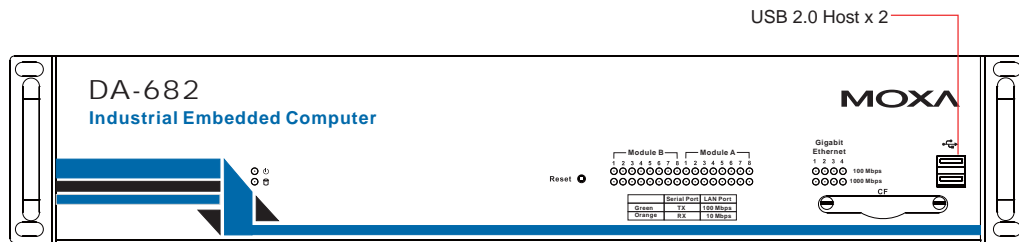



## Gigabit LAN Ports

The DA-682 Basic System has 4 Gigabit LAN ports. When the cable is properly connected, the LEDs on the RJ45 connectors will glow to indicate a proper connection.

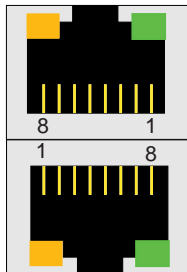
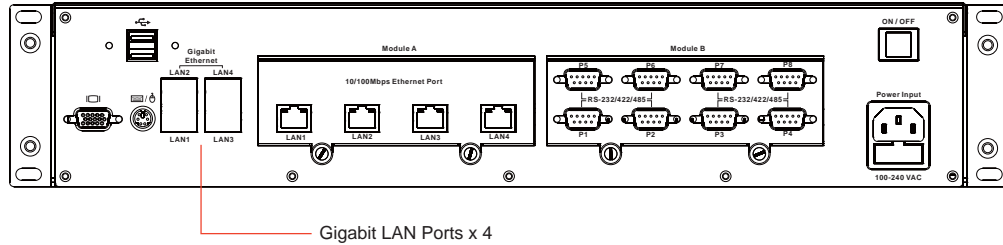

Pin	10/100 Mbps	1000 Mbps
1	ETx+	TRD(0)+
2	ETx-	TRD(0)-
3	ERx+	TRD(1)+
4	---	TRD(2)+
5	---	TRD(2)-
6	ERx-	TRD(1)-
7	---	TRD(3)+
8	---	TRD(3)-

LED	Color	Description
Gigabit RJ45 Connector	Green	100 Mbps Ethernet mode
	Orange	1000 Mbps (Gigabit) Ethernet mode
	Off	Not operating or 10 Mbps Ethernet mode

The default IP addresses and netmasks of the Gigabit LAN ports are as follows:

	Default IP Address	Netmask
LAN 1	192.168.3.127	255.255.255.0
LAN 2	192.168.4.127	255.255.255.0
LAN 3	192.168.5.127	255.255.255.0
LAN 4	192.168.6.127	255.255.255.0

## Upgrading the Memory Module

The DA-682 embedded computer supports one 200-pin DDR2 400/533 SODIMM module, up to 1GB. One DDR2 SDRAM memory module is installed at the factory. To upgrade the DDR2 SDRAM memory module, follow these instructions:

1. Disconnect the DA-682 from the power source.
2. The DA-682's memory module is located inside the DA-682's bottom panel. Turn the DA-682 upside down, and unscrew the memory module cover.

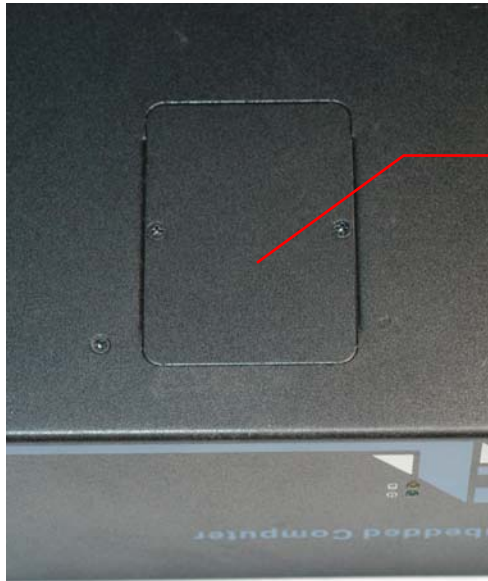

**Memory Module Cover**

3. After removing the memory module cover, you should see the DDR2 SDRAM module.



**Factory installed DDR2 SDRAM module.**

4. Carefully remove and replace the memory module. Be sure to orient the module correctly.



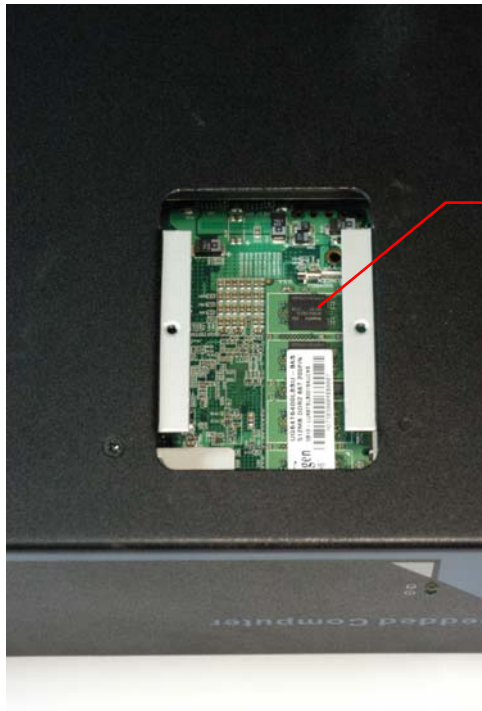

**Orient the memory module correctly**

5. Replace the DA-682 memory module cover.

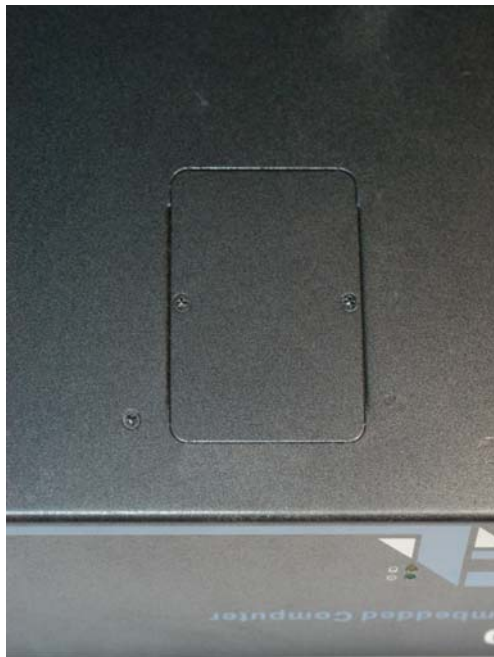

## Installing a CompactFlash Card

The DA-682 embedded computer comes with a CompactFlash socket. To insert a CompactFlash card, follow these instructions.

1. Disconnect the DA-682 from its power source.
2. The DA-682's CompactFlash socket is located on the right side of front panel. Unscrew the CompactFlash socket cover.



CF Socket  
Cover



Unscrew the CF  
socket cover

3. There is a tenon/hook on the cover of CF socket. Turn the CompactFlash card over and then insert the CompactFlash card into the tenon/hook of CF socket cover.

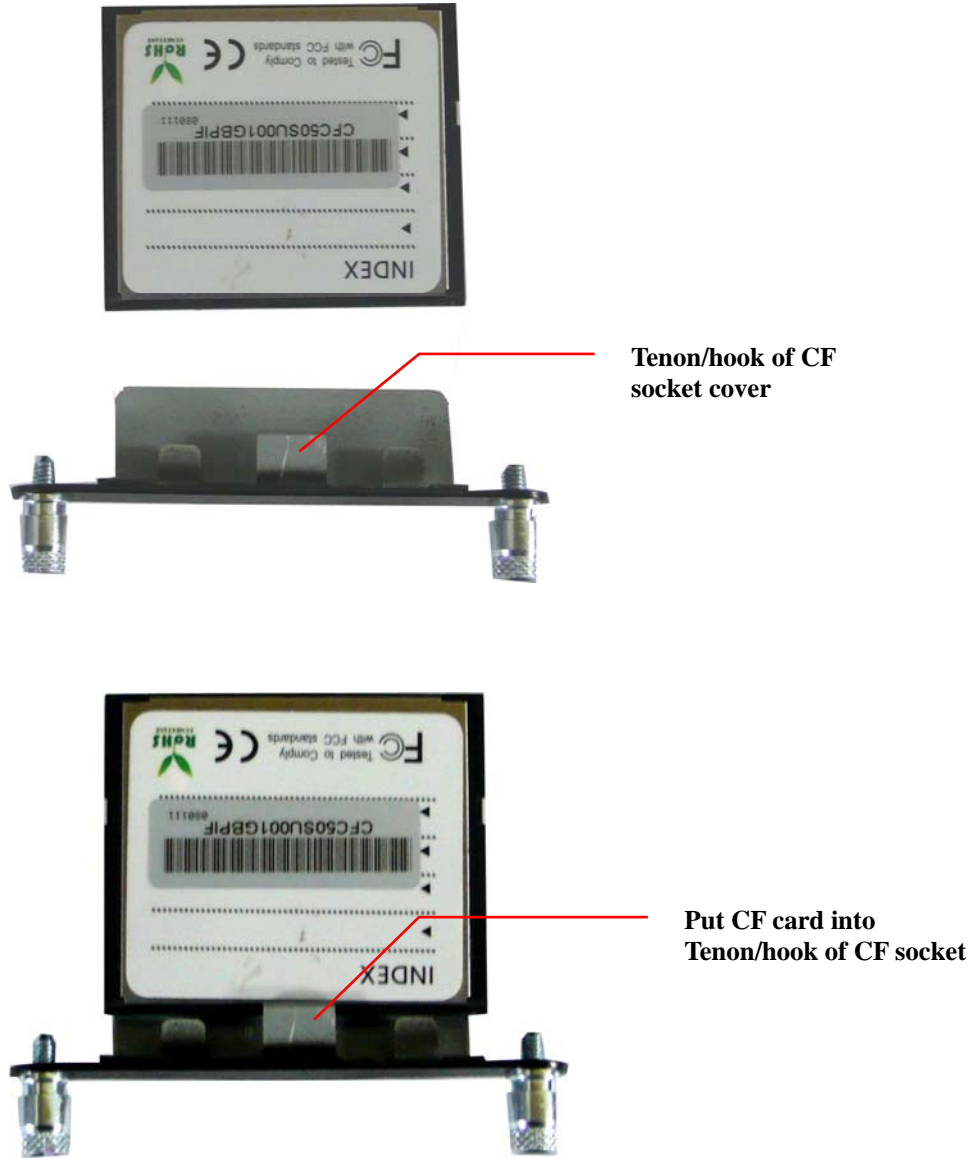

**ATTENTION**

Be careful of how you orient the CompactFlash card. You should turn the CF card bottom side up, in order to hook CF card into CF socket cover.

4. Gently insert the CompactFlash card into the CF socket, making sure that the card is oriented correctly.

**ATTENTION**

The DA-682 embedded computer does not support the CompactFlash hot swap and PnP (Plug and Play) functions. It is necessary to remove power source first before inserting or removing the CompactFlash card.



## Installing a SATA Hard Disk

The DA-682 embedded computer has one SATA connector for installing a SATA hard disk. To install a 2.5-inch SATA hard disk, follow these instructions.

1. Disconnect the DA-682 from its power source.
2. Open the top cover of the DA-682. A hard disk bracket is located on the right side of the DA-682.

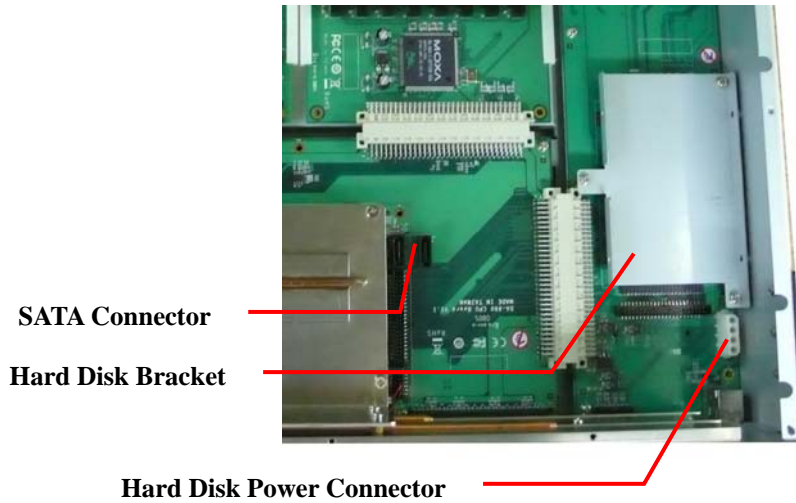

3. Remove hard disk bracket.





4. Install the SATA hard disk in the hard disk bracket.



5. Next, install the SATA hard disk and hard disk bracket back into the DA-682.



6. Connect the SATA disk cable and power cable to the SATA hard disk.



SATA Disk Cable

SATA Power Cable



**ATTENTION**

The SATA hard disk cable and SATA power cable are not included in the basic shipment of the DA-682 embedded computer. Any standard SATA disk cable and power cable can be used.

## Inserting and Removing Expansion Modules

The DA-682 embedded computer has two expansion slots for inserting expansion modules. Expansion modules can be installed in either on Slot A or Slot B. To insert or remove expansion modules, follow these instructions.

1. Disconnect the DA-682 from the power source.
2. Unscrew expansion module A or module B on the rear panel.

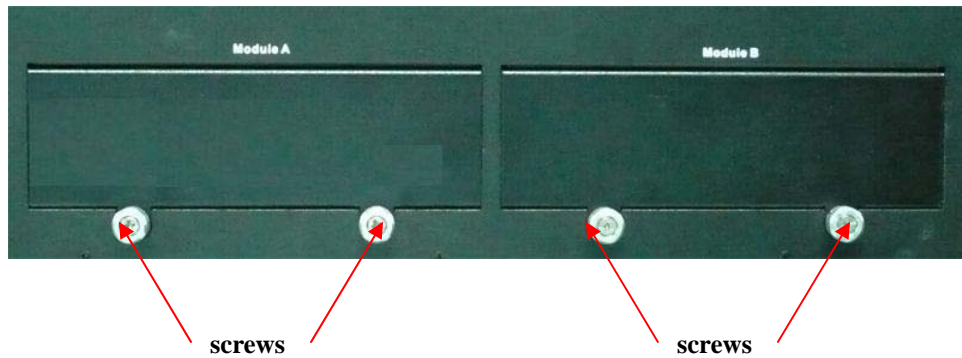

- Carefully insert or remove the expansion module by pushing or pulling on the two screws at the same time. By pushing or pulling on the two screws evenly, you can ensure that the board is inserted or removed without being damaged.

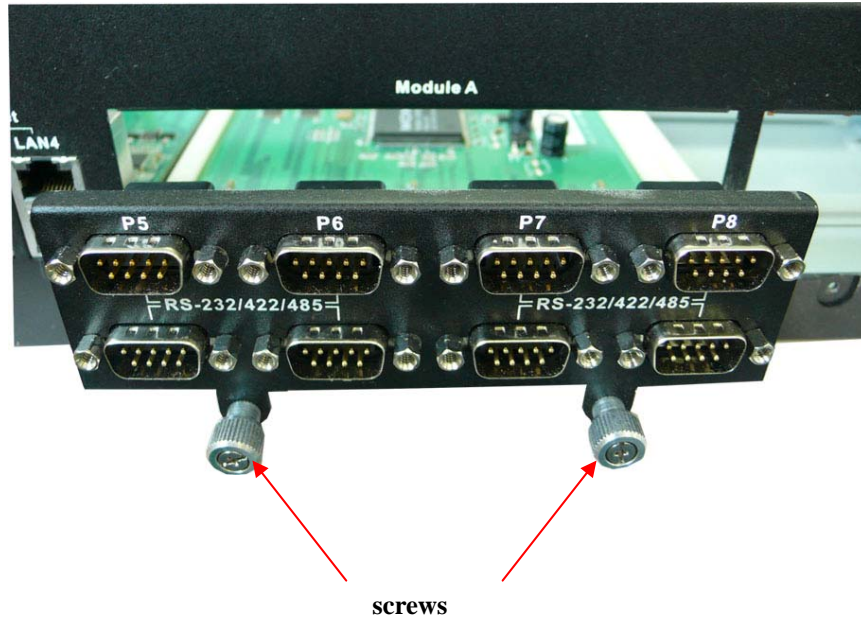

### DA-SP08-I-DB/DA-SP08-DB Serial Expansion Modules

The DA-SP08-I-DB and DA-SP08-DB serial expansion modules have 8 software-selectable serial ports with DB9 connectors. The DA-SP08-I-DB supports 2 KV isolation protection for all signals. Each port can be configured by software for RS-232, RS-422, or RS-485.

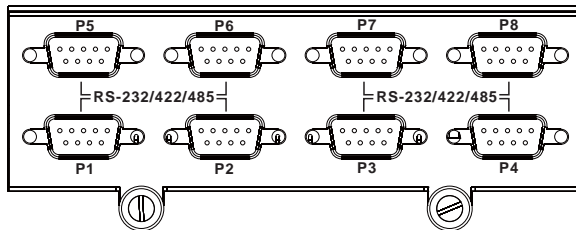

The pin assignments for the ports are shown in the following table:

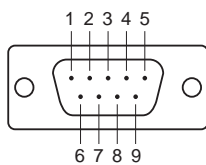

Pin	RS-232	RS-422	RS-485 (4-wire)	RS-485 (2-wire)
1	DCD	TxDA(-)	TxDA(-)	---
2	RxD	TxDB(+)	TxDB(+)	---
3	TxD	RxDB(+)	RxDB(+)	DataB(+)
4	DTR	RxDA(-)	RxDA(-)	DataA(-)
5	GND	GND	GND	GND
6	DSR	---	---	---
7	RTS	---	---	---
8	CTS	---	---	---

## DA-SP08-I-TB Serial Expansion Module

The DA-SP08-I-TB serial expansion module has 8 software-selectable isolated serial ports with 5-pin terminal blocks. Each port can be configured by software for RS-232, RS-422, or RS-485.

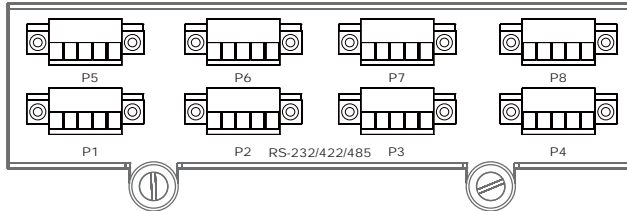

The pin assignments for the ports are shown in the following table:

Pin	RS-422	RS-485 (2-wire)	RS-232
1	TXD+		TXD
2	TXD-		RXD
3	RXD+	DATA+	RTS
4	RXD-	DATA-	CTS
5	GND	GND	GND

## DA-LN04-RJ LAN Expansion Module

The DA-LN04-RJ LAN expansion module has 4 10/100 Mbps Ethernet ports with RJ45 connectors.

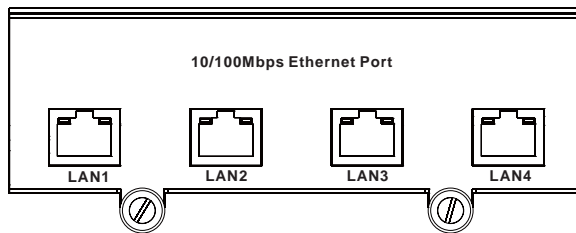

The pin assignments for the ports are shown in the following table:

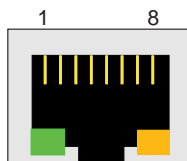

Pin No.	Signal Definition
1	TX+
2	TX-
3	RX+
4	---
5	---
6	RX-
7	---
8	---

There are two LEDs on each RJ45 port for indicating the status of the port.

<b>LED</b>	<b>Color</b>	<b>Description</b>
RJ45 Connector	Green	100 Mbps Ethernet mode
	Yellow	10 Mbps Ethernet mode
	Off	Inactive

This chapter describes the BIOS settings of the DA-682 embedded computers. The BIOS is a set of input/output control routines for peripherals. The BIOS is used to initialize basic peripherals and helps boot the operating system before the operating system is loaded. The BIOS setup allows the user to modify the system configurations of these basic input/output peripherals. All of the configurations will be stored in the battery backed up CMOS RAM, which retains the system information after system reboots or the power is removed.

This chapter covers the following topics:

- ❑ **Entering the BIOS Setup Utility**
- ❑ **Modifying the BIOS Main Settings**
  - Basic Configuration
  - System Security
- ❑ **Advanced Settings**
  - Hard Disk Boot Priority
  - Advanced BIOS Features
  - CPU Features
  - Advanced Chipset Settings
  - PnP/PCI Configurations
  - Frequency/Voltage Control
- ❑ **Peripherals**
  - OnChip IDE Device
  - Onboard Device
  - Onboard GigaLan Control
  - Onboard I/O Chip Setup
- ❑ **Power**
  - Wake Up Control
- ❑ **Hardware Monitor**
- ❑ **Load Defaults**
- ❑ **Exiting the BIOS Setup**
- ❑ **Upgrading the BIOS**

## Entering the BIOS Setup Utility

To enter the BIOS setup utility, press the “Del” key while the system is booting up. The main BIOS Setup screen will appear.

A basic description of each function key is listed at the bottom of the screen. Refer to these descriptions to learn how to scroll about the screen, how to select by pressing “Enter,” and how to use the other hot keys listed below.

F1: General Help

F5: Previous Value

F6: Default Settings

F7: Turbo Settings

F10: Save

ESC: Exit

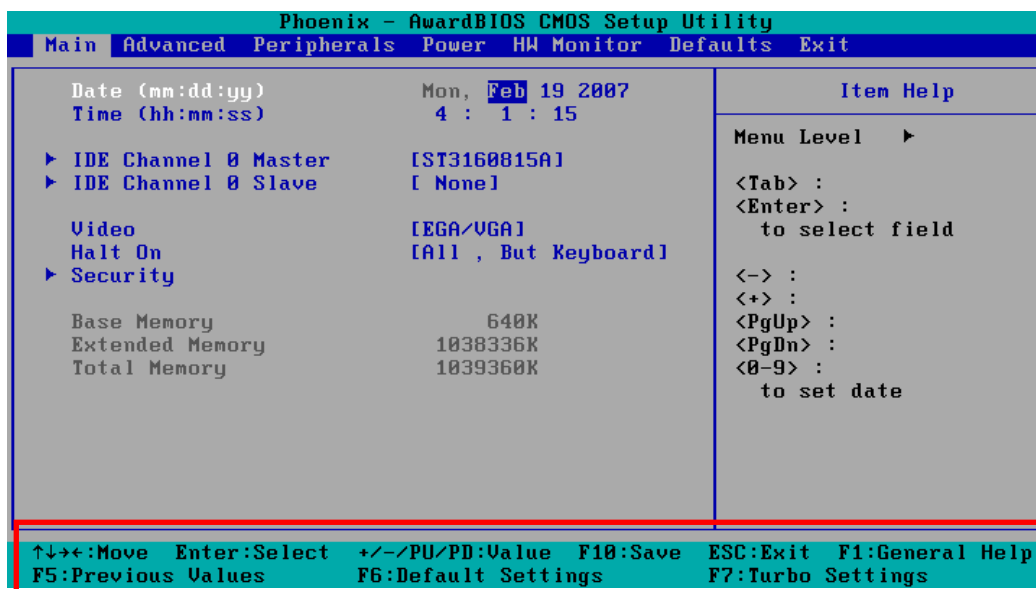

## Modifying the BIOS Main Settings

### Basic Configuration

After entering the BIOS Setup, or choosing the “Main” option, the BIOS main menu will be displayed. Use this menu to check the basic system information such as memory and IDE hard drive. You can also use the menu for configuring basic system parameters, such as date, time, hard drive, display, and system security.

## System Security

To set up system security, select the “Security” option under “Main” to bring up the following screen.

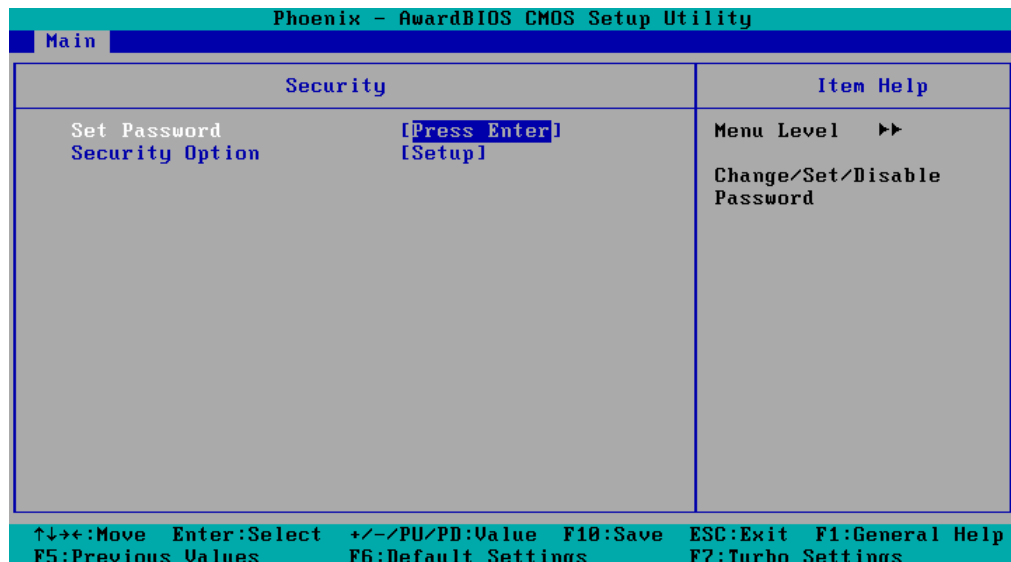

This menu includes two options: “Set Password” and “Security Option.”

When you select the Set Password option, a pop-up “Enter Password:” window will appear on the screen. The password that you type will replace the password stored in the CMOS memory. You will be required to confirm the new password. Just re-type the password and then press <Enter>. You may also press <Enter> to abort the selection and not enter a password.

To clear an existing password, just press <Enter> when you are prompted to enter the password. A message will show up confirming that the password will be disabled. Once the password is disabled, the system will boot and you can enter the “BIOS Setup Menu” without entering a password.

Once a password has been set, you will be prompted to enter the password each time you enter Setup. This prevents unauthorized persons from changing any part of your system configuration. In addition, when a password setting is enabled, you can set up the BIOS to request a password each time the system is booted up. The “Security Option” setting determines when a password prompt is required. If the “Security Option” is set to “System,” the password must be entered both at boot up and when entering the BIOS Setup Menu. If the password is set for “Setup,” the password prompt only occurs when you enter the “BIOS Setup Menu.”



## Advanced Settings

The “Advanced Features” screen will appear when choosing the “Advanced” item from the main menu.

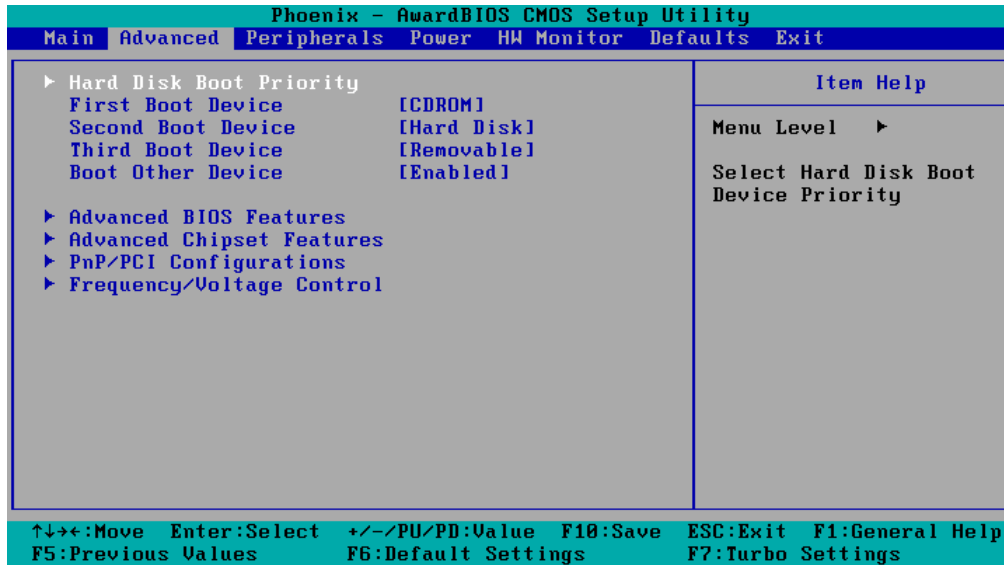

### Hard Disk Boot Priority

#### First/Second/Third Boot Device

This option allows users to select or change the device boot priority. You may set 3 levels of priority to determine the boot up sequence for different bootable devices, such as a hard drive, CD-ROM, and removable devices. Select the order in which devices will be searched in order to find a boot device. The available options are “CDROM (default for first boot device),” “Removable” (default for third boot device), “Hard Disk” (default for second boot device) and “Disabled.”

#### Boot Other Devices

This setting allows the system to try to boot from other devices if the system fails to boot from the 1st, 2nd, or 3rd boot devices. The options are “Enabled” (default) and “Disabled.”

## Advanced BIOS Features

When you select the “Advanced BIOS Features” option under the “Advanced” menu, the following configuration menu will appear.

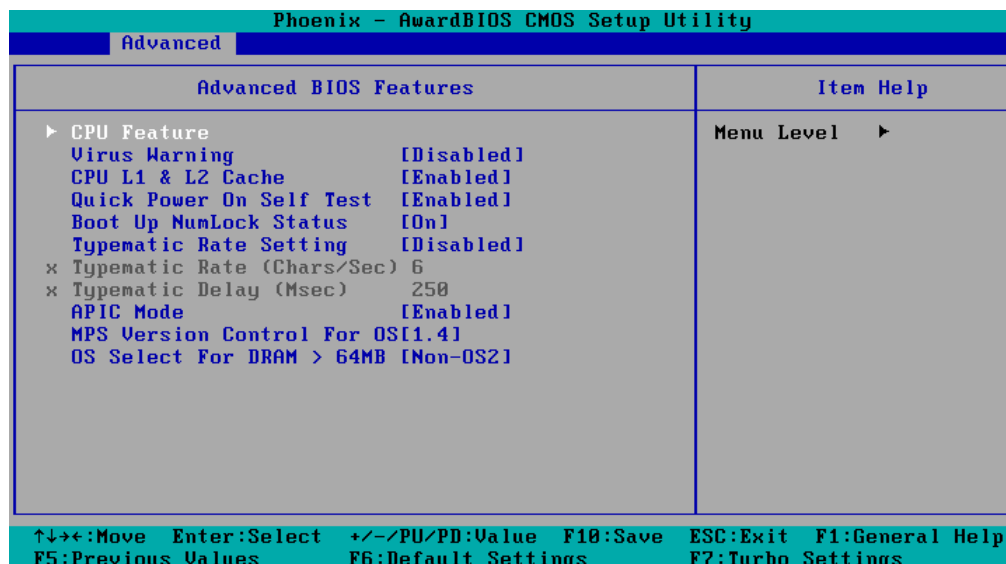

## CPU Features

### Virus Warning

This item allows you to choose the VIRUS warning feature for IDE hard disk boot sector protection. If this function is enabled and someone attempts to write data into this area, the BIOS will display a warning message on the screen and sound an audio alarm (beep).

Options: Disabled (default), Enabled.

### CPU L1 & L2 Cache

Make the CPU internal cache active or inactive. System performance may degrade if you disable this item.

Options: Enabled (default), Disabled.

### Quick Power on Self Test

This setting allows the system to skip certain tests while the system boots up. Enable this feature to speed up the boot up process.

Options: Enabled (default), Disabled.

### Boot Up NumLock Status

Select the power on state for NumLock.

Options: On (default), Numpad keys are number keys.

Off, Numpad keys are arrow keys.

### Typematic Rate Setting

When "Enabled" both "Typematic Rate" and "Typematic Delay" can be configured. Typematic Rate determines the keystroke repeat rate used by the keyboard controller.

Options: Disabled (default), Enabled

### Typematic Rate (Chars/Sec)

The rate at which the keyboard will repeat a keystroke if users press key continuously.

### Typematic Delay (milliseconds)

The delay before keystrokes begin to repeat.

Options: 250 ms (default), 500 ms, 750 ms, 1000 ms

### APIC Mode

Set the "Advanced Programmable Interrupt Controller" as active or inactive.

Options: Disabled, Enabled (default)

### MPS Version Control for OS

Set the "Multi-Processor Specification." 1.1 was the original specification. MPS version 1.4 adds extended configuration tables for improved support for multiple PCI bus configurations and greater expandability. In addition, MPS 1.4 introduces support for a secondary PCI bus without requiring a PCI bridge.

Options: 1.1, 1.4 (default)

### OS Select for DRAM > 64 MB

Select "OS2" only if you are running the OS/2 operating system with greater than 64 MB of RAM.

Options: Non-OS2 (default), OS2

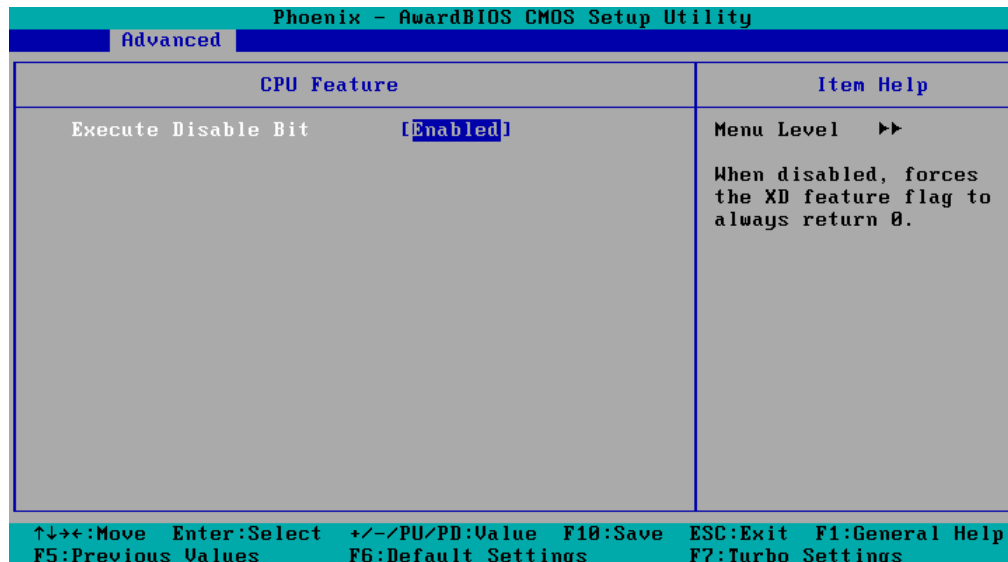

### Execute Disable Bit

Intel hardware-based security feature can help reduce system exposure to viruses and malicious code.

Options: Enabled (default), Disabled.

### Advanced Chipset Settings

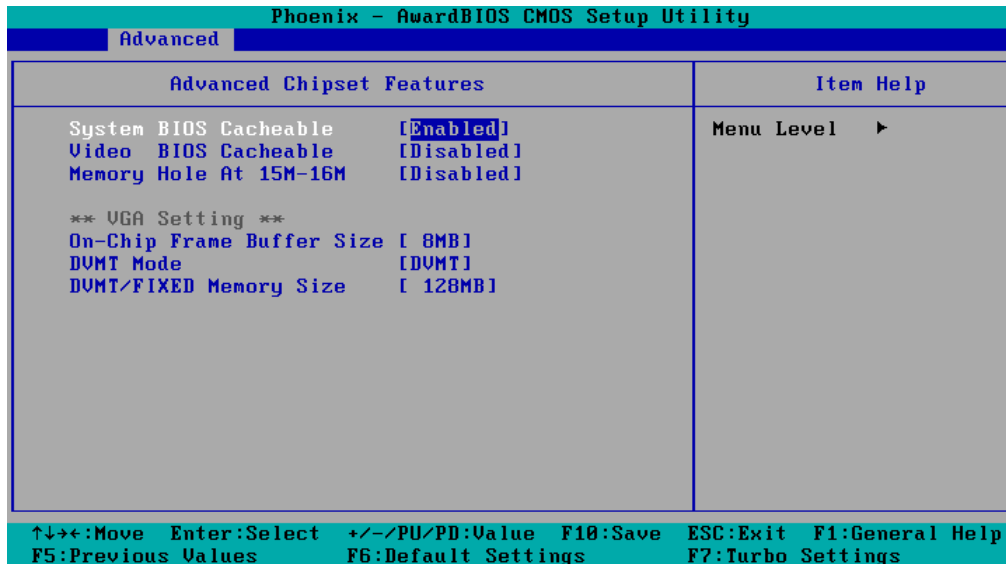

#### System BIOS Cacheable

The BIOS ROM addresses F0000h to FFFFFh are cached, and the cache controller is enabled to access the system. Enable it to speed up system performance.

Options: Enabled (default), Disabled

#### Video BIOS Cacheable

Enabling this feature allows the caching of the video BIOS and may improve performance. A system error could occur if another program writes to this memory cache area.

Options: Enabled, Disabled (default)

#### Memory Hole at 15M-16M

When enabled, the system will reserve a system memory area for the ISA adapter ROM, and this memory area will not be available for caching.

Options: Enabled, Disabled (default)

#### On-Chip Frame Buffer Size

This item determines the frame buffer size for the VGA function, and will share the system memory.

Options: 1 MB, 8 MB (default)

## DVMT Mode

Setting the DVMT operating mode. When set to “Fixed,” the graphics driver will reserve a fixed portion of the system memory as graphics memory. When set to “DVMT,” the graphics driver will dynamically allocate system memory as graphics memory, according to system and graphics requirements. When set to “BOTH,” the graphics driver will allocate a fixed amount of memory as dedicated graphics memory, as well as allow more system memory to be dynamically allocated between the graphics processor and the operating system.

Options: FIXED, DVMT (default), BOTH

## DVMT/FIXED Memory Size

Sets the maximum amount of system memory that can be allocated as graphics memory.

Options: 64 MB, 128 MB (default).

## PnP/PCI Configurations

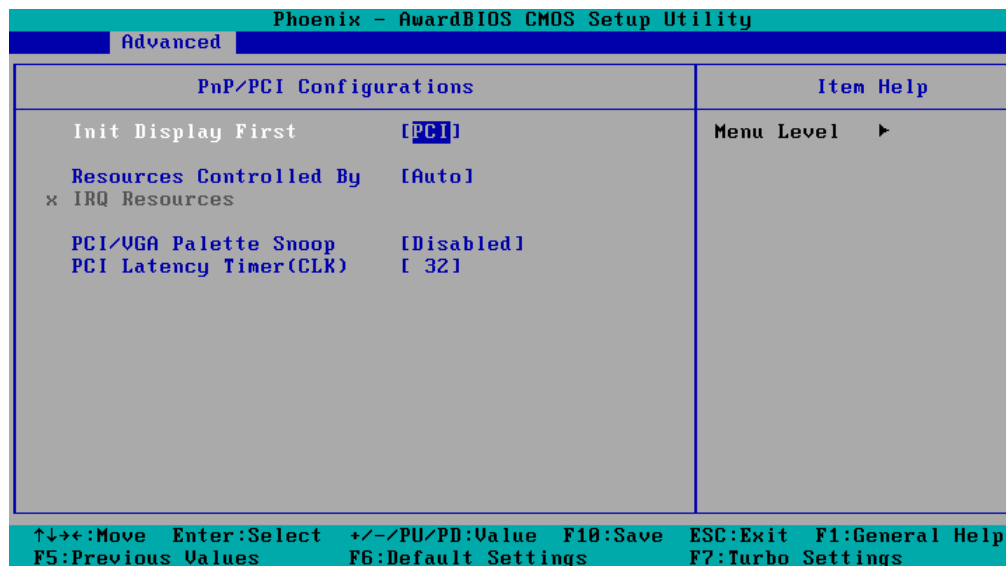

### Init Display First

This item allows you to decide whether the PCI interface or onboard graphic chip is activated first.

Options: PCI (default), Onboard

### Resources Controlled By

The BIOS can automatically configure all boot and Plug and Play compatible devices. If you choose Auto, you will not be able to assign IRQ and memory base address fields manually, since the BIOS assigns them automatically.

Options: Auto (default), Manual

### IRQ Resources

When resources are controlled manually, you can assign each system interrupt to Reserved or PCI device. This is only configurable when “Resources Controlled By” is set to “Manual.”

Options: IRQ 3, 4, 5, 7, 10, 11 for PCI device.

### PCI/VGA Palette Snoop

This item can be used to fix the color display error of non-standard VGA display adaptors such as graphics accelerators or MPEG video cards.

Options: Disabled (default), Enabled

### PCI Latency Timer (CLK)

Configure PCI Latency Time to optimize the PCI speed. The range of possible values is "0" to "255" with a default value of "32."

## Frequency/Voltage Control

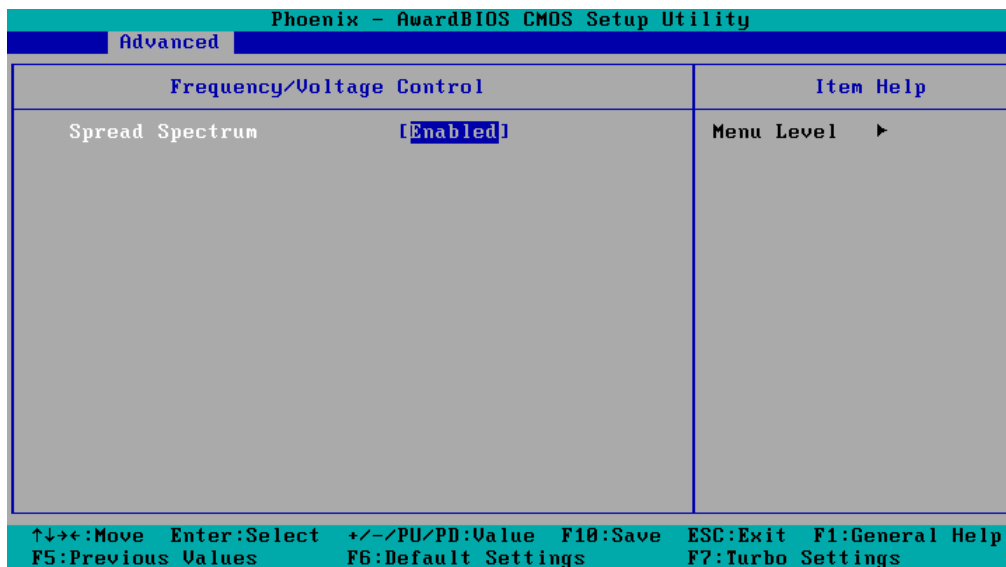

### Spread Spectrum

Select "Enabled" to reduce EMI (Electromagnetic Interference). The default is "Enabled."

## Peripherals

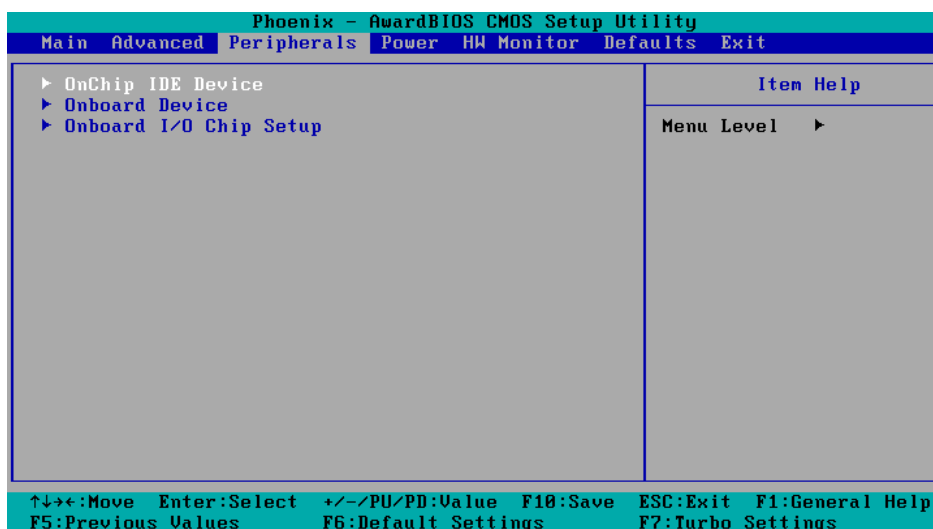

## OnChip IDE Device

Phoenix - AwardBIOS CMOS Setup Utility	
Peripherals	
OnChip IDE Device	Item Help
IDE HDD Block Mode [Enabled]	Menu Level ▶▶
On-Chip Channel 0 PCI IDE [Enabled]	If your IDE hard drive supports block mode select Enabled for automatic detection of the optimal number of block read/writes per sector the drive can support
IDE Channel 0 Master PIO [Auto]	
IDE Channel 0 Slave PIO [Auto]	
IDE Channel 0 Master UDMA [Auto]	
IDE Channel 0 Slave UDMA [Auto]	
On-Chip Channel 1 PCI IDE [Enabled]	
IDE Channel 1 Master PIO [Auto]	
IDE Channel 1 Slave PIO [Auto]	
IDE Channel 1 Master UDMA [Auto]	
IDE Channel 1 Slave UDMA [Auto]	

↑↓→←:Move    Enter:Select    +/~/PU/PD:Value    F10:Save    ESC:Exit    F1:General Help  
 F5:Previous Values    F6:Default Settings    F7:Turbo Settings

### IDE HDD Block Mode

Block mode is otherwise known as block transfer, multiple commands, or multiple sector read/write. Select the “Enabled” option if your IDE hard drive supports block mode (most new drives do). The system will automatically determine the optimal number of blocks to read and write per sector.

Options: Enabled (default), Disabled

### On-Chip Channel 0/1 PCI IDE

This item lets users enable or disable the IDE channel.

Options: Disabled, Enabled (default)

### IDE Channel 0/1 Master/Slave PIO

The IDE PIO (Programmed Input/Output) fields let you set a PIO mode (0-4) for each of the IDE devices that the onboard IDE interface supports. Modes 0 to 4 will increase performance incrementally. In Auto mode, the system automatically determines the best mode for each device.

Options: Auto (default), Mode0, Mode1, Mode2, Mode3, Mode4

### IDE Channel 0/1 Master/Slave UDMA

Ultra DMA functionality can be implemented if it is supported by the IDE hard drives in your system. Your operating environment also requires a DMA driver (Windows 95 OSR2 or a third party IDE bus master driver). If your hard drive and your system software both support Ultra DMA, select “Auto” to enable BIOS support.

Options: Auto (default), Disabled

## Onboard Device

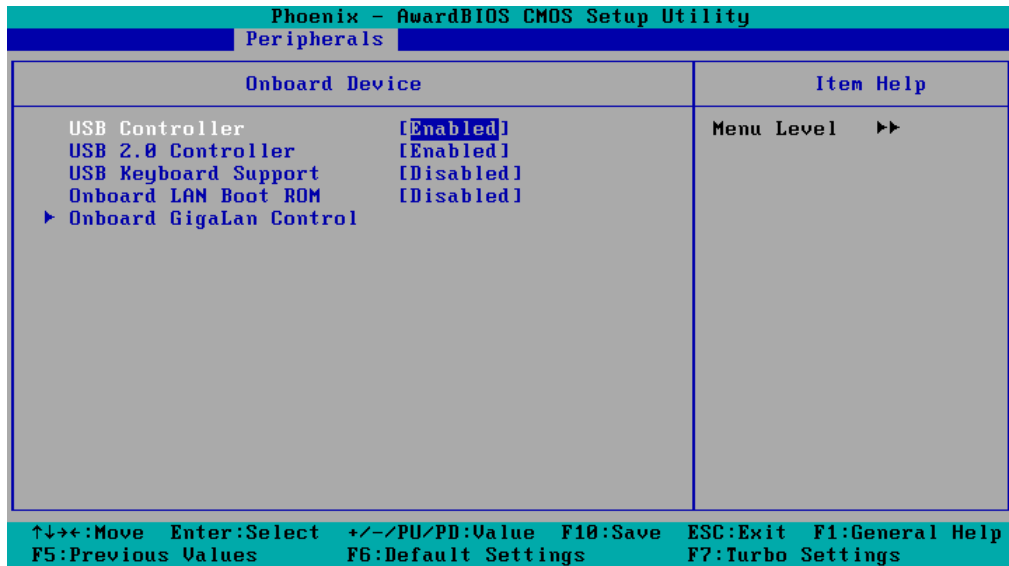

### USB Controller

This feature allows you to enable/disable the USB controller.

Options: Enabled (default), Disabled

### USB 2.0 Controller

This feature allows you to enable/disable the USB 2.0 controller.

Options: Enabled (default), Disabled

### USB Keyboard Support

This item is useful for DOS systems. Enable it if you want to use a USB keyboard under a DOS environment.

Options: Enabled, Disabled (default)

### Onboard LAN Boot ROM

Decide whether to invoke the boot ROM of the onboard LAN chip.

Options: Enabled, Disabled (default)



### Onboard GigaLan Control

Phoenix - AwardBIOS CMOS Setup Utility	
Peripherals	
Onboard GigaLan Control	Item Help
GigaLan 1 [Enabled]	Menu Level ▶▶
GigaLan 2 [Enabled]	
GigaLan 3 [Enabled]	
GigaLan 4 [Enabled]	
↑↓→←:Move Enter:Select +/-/PU/PD:Value F10:Save ESC:Exit F1:General Help F5:Previous Values F6:Default Settings F7:Turbo Settings	

#### GigaLan 1/2/3/4

Used to Enable/Disable the onboard Giga LAN controller.

Options: Enabled (default), Disabled

### Onboard I/O Chip Setup

Phoenix - AwardBIOS CMOS Setup Utility	
Peripherals	
Onboard I/O Chip Setup	Item Help
Debug Port [Disabled]	Menu Level ▶▶
PWRON After PWR-Fail [On]	
↑↓→←:Move Enter:Select +/-/PU/PD:Value F10:Save ESC:Exit F1:General Help F5:Previous Values F6:Default Settings F7:Turbo Settings	

### Debug Port

Select an address and corresponding interrupt for this debug port. This port is only for engineers who are debugging programs.

Options: Disabled (default), 3F8/IRQ4

### PWRON after PWR-Fail

This field determines whether your system will boot after restoring power from a power failure. If you select "On," the system will boot after restoring power from a power failure. If you select "Former-Sts" (Former Status), the system will boot or not, depending on the status before the power failure.

Options: Off, On (default), Former-Sts.

## Power

The Power Setup Menu allows you to configure your system power-up/ power-down options.

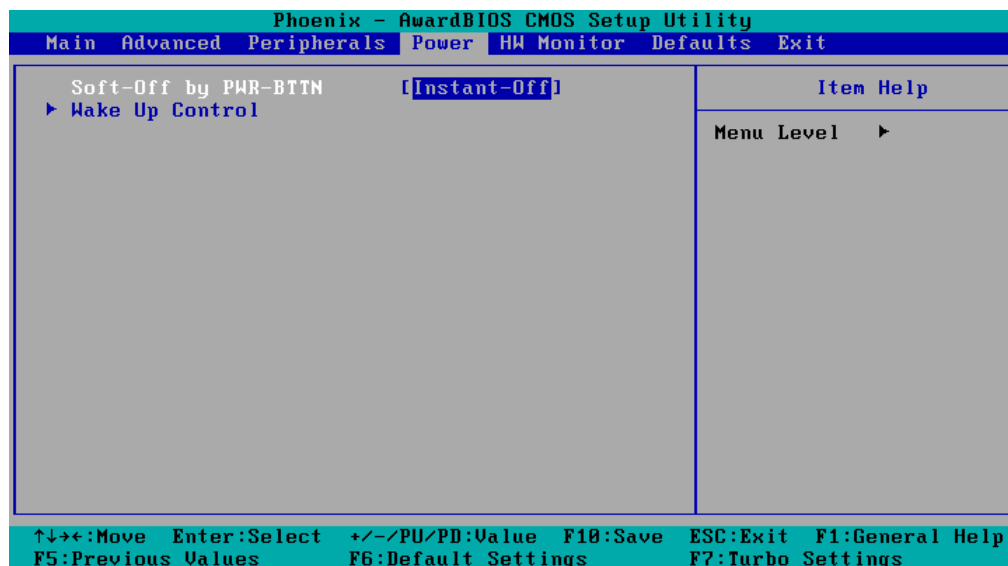

### Soft-Off by PWR-BTTN

Select the "Instant-Off" option if you would like the system to power down immediately after pushing the power button. Selecting the "Delay 4 Sec" option will require pushing the power button continuously for at least 4 seconds before the system powers down.

Options: Delay 4 Sec, Instant-Off (default).

## Wake Up Control

Press "Enter" to select Wake Up Control items.

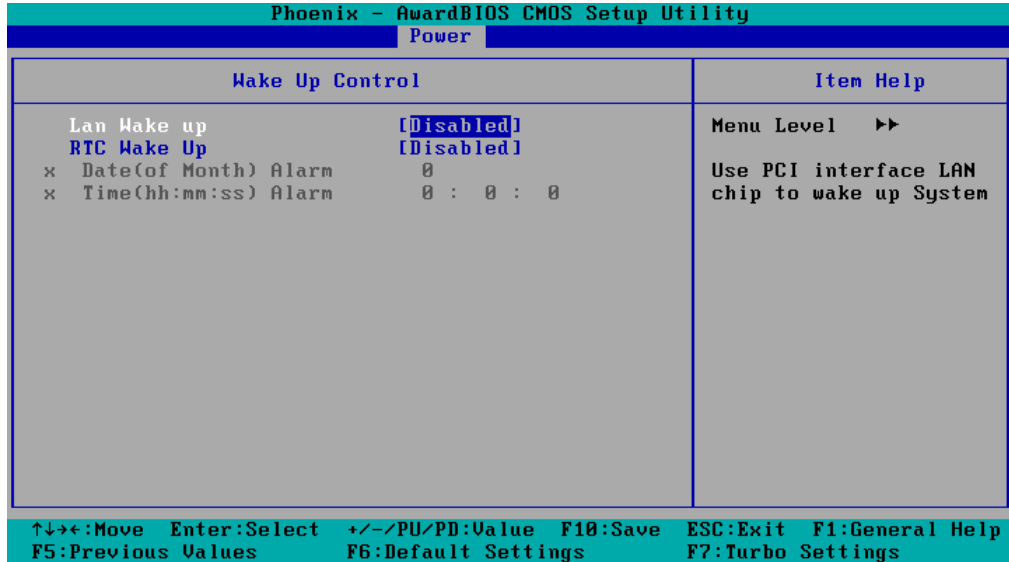

### Lan Wake up

This feature is used to wake up the system by a LAN device from a remote host. Users can select the PCI interface. **Please note that this function is only for working with the DA-LN04-RJ LAN module.**

Options: Disabled (default), PCI

### RTC Wake Up

When "Enabled," you can set the date and time at which the RTC (real-time clock) alarm awakens the system from Suspend mode.

Options: Disabled (default), Enabled.

### Date (of Month) Alarm

Set the "date" for the "RTC Wake Up" function when "RTC Wake Up" is set to "Enabled."

### Time (hh: mm: ss) Alarm

You can set the hour, minute, and second of the "RTC Wake Up" function when "RTC Wake Up" is set to "Enabled."

## Hardware Monitor

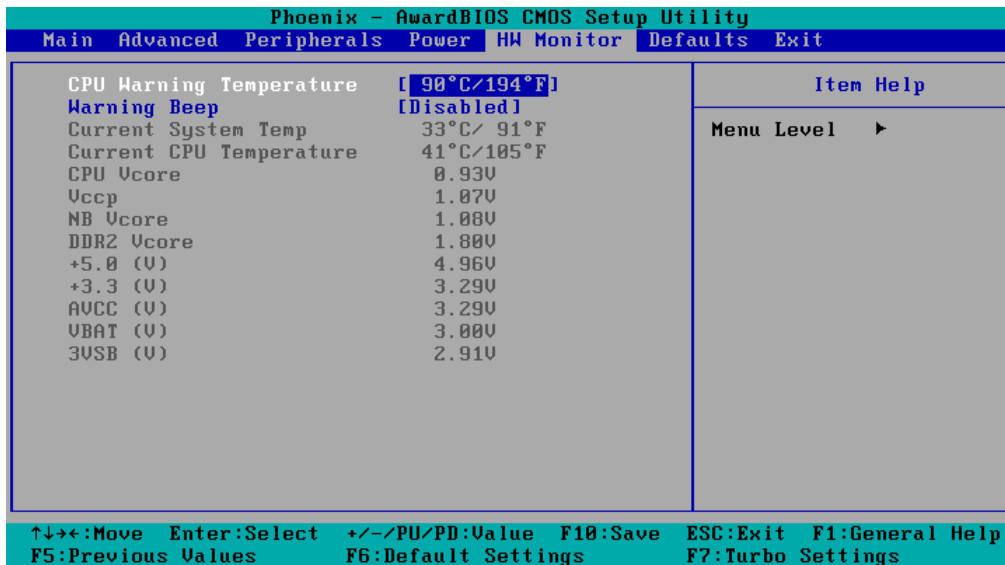

### CPU Warning Temperature

This item sets the CPU warning temperature. When the CPU temperature is higher than this setting, the system will throttle down to 75%. When the CPU temperature is higher than this setting plus 10°C, the system will throttle down to 50%.

Options: 80°C/176°F, 90°C/194°F (default), 100°C/212°F, Disabled.

### Warning Beep

Set the beep to sound or not sound when the CPU temperature is over the CPU warning temperature.

Options: Disabled (default), Enabled.

## Load Defaults

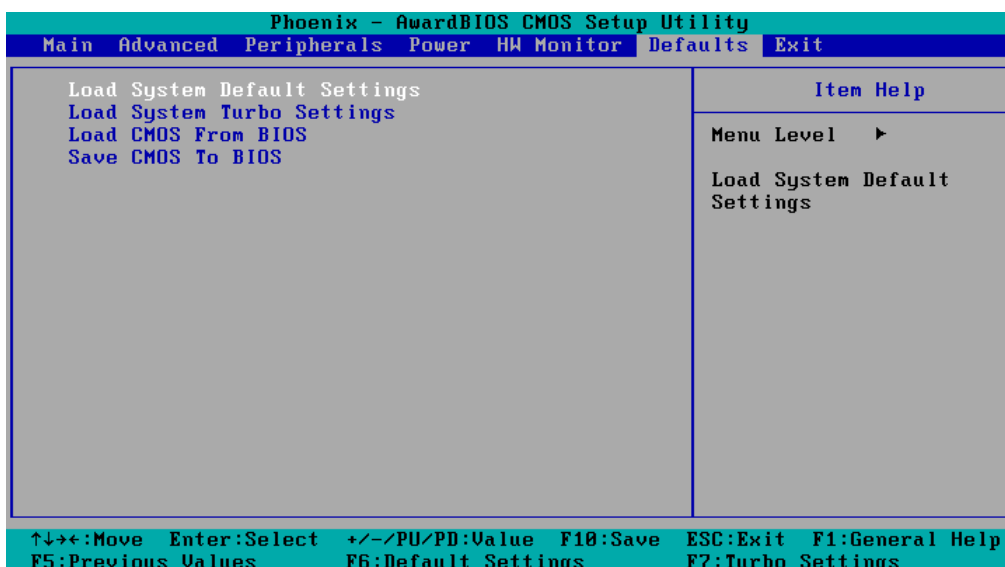

### Load System Default Settings

Use this option to load system factory default settings instead of the current BIOS settings. This option is useful for when the system is unstable. Users do not need to remember what settings were active before the system fails.

### Load System Turbo Settings

Use this option to load system optimized settings. If the system is not stable, please load the system default settings.

### Load CMOS from BIOS

Use this option to load BIOS settings from flash ROM to CMOS.

### Save CMOS to BIOS

Use this option to save the BIOS settings from the CMOS to flash ROM.

## Exiting the BIOS Setup

To exit the BIOS setup utility, choose "Exit." Pressing <ESC> will achieve the same result.

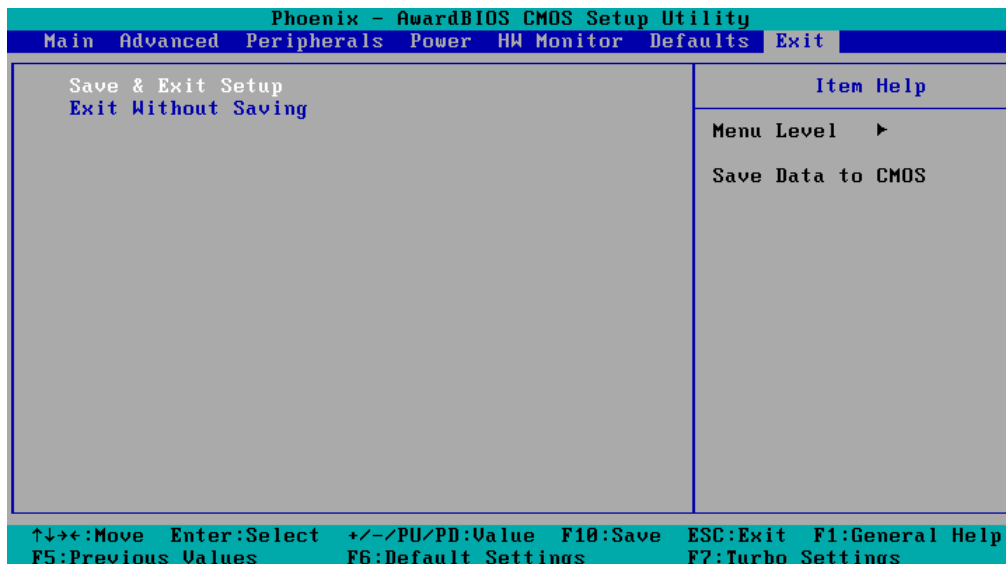

### Save & Exit Setup

Save all configuration changes to CMOS (memory) and exit setup. A confirmation message will be displayed before proceeding.

### Exit Without Saving

Abandon all changes made during the current session and exit setup. A confirmation message will be displayed before proceeding.

## Upgrading the BIOS

This section describes how to upgrade the bios.

### Step 1: Create a Bootable USB Disk.

There are two recommended methods for creating a bootable USB disk:

#### Method 1: Use HP USB Disk Format Tool

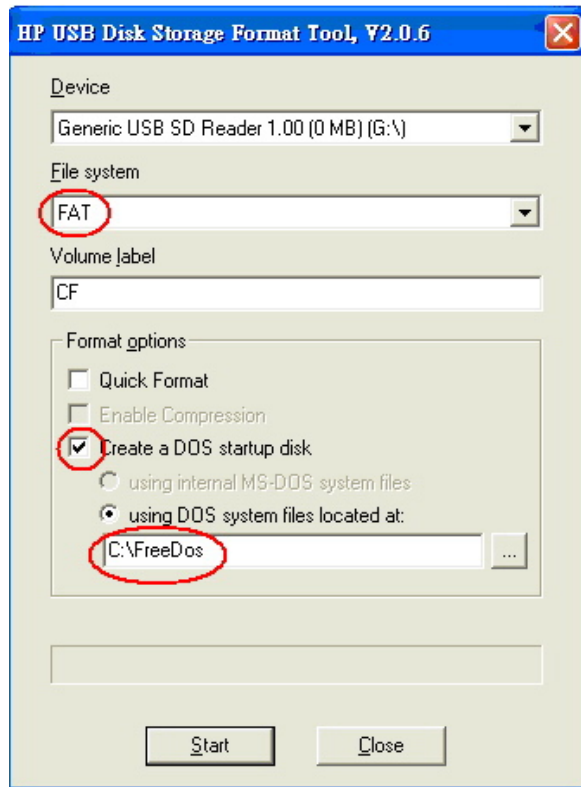

1. Download FreeDOS system files **kernel.sys** and **command.com** from <http://www.freedos.org/kernel/>
2. Copy DOS system files **kernel.sys** and **command.com** to a specified directory (**C:\FreeDOS** in this example).
3. Start the HP USB Disk Storage Format Tool and select the USB device that you want to use as a bootable disk in the **Device** drop down box.
4. Select **FAT** in the **File system** drop down box.
5. Type the disk name in the **Volume label field**.
6. Check the option **Create a DOS startup disk** under format options.
7. Specify the directory of the system files (for example, **C:\FreeDOS**).
8. Click **Start** to format and create the USB disk.

**ATTENTION**

HP's USB Disk Storage Format Tool can be downloaded from many web sites. Use the phrase "HP USB Disk Storage Format Tool" to search the Internet, and then download the tool from one of the websites that is listed.

**Method 2:** Use the BootFlashDOS utility.

Run the BootFlashDOS utility and then press **Start**.

**ATTENTION**

The BootFlashDOS utility can be downloaded from the following website:  
<http://gocoding.com/page.php?al=bootflashdos>.

**Step 2: Prepare the Upgrade Tool and BIOS Binary File.**

You must use the BIOS upgrade installation file to upgrade the BIOS. You can download it from the Moxa Download Center at:

[http://web4.moxa.com/support/download\\_center.asp](http://web4.moxa.com/support/download_center.asp)

1. Get the BIOS upgrade installation file. The file name should have following format:  
**BIOS\_DA-68X\_V1.0\_Build\_08042310.zip**.
2. Copy the file to the Bootable USB Disk.
3. Double click to extract the BIOS update installation file. The file includes a binary file in the form xxxxxxx.Sxx and the upgrade utility named **awdf flash.exe**.

**Step 3: Set up the BIOS to Boot from the USB Disk.**

1. Insert the USB disk.
2. Power on and press **DEL** to enter the BIOS Setup menu.
3. Select **Advanced** → **Hard Disk Boot Priority** and then press **Enter**.
4. From the Setup menu, use “↑” or “↓” to select the USB device.
5. Press “+” to move it up to the first priority, and press “Esc” to exit the setup menu.
6. Make sure the first boot device is **Hard Disk**. If it isn't, press **Enter** to change it.
7. Select **Exit** → **Save & Exit Setup** and then press **Enter**.
8. Choose **Y** to save to the CMOS and then exit.

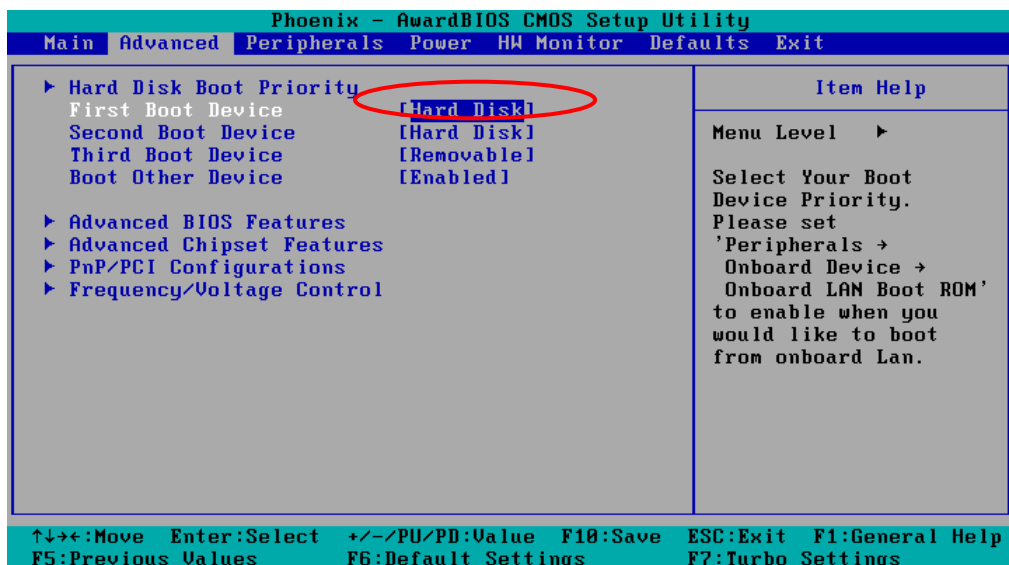
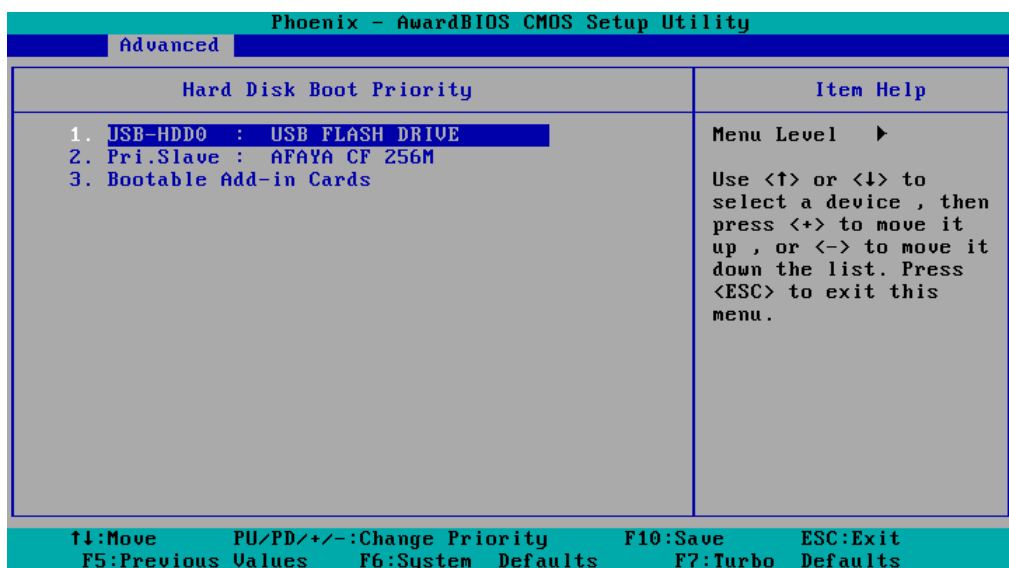



**Step 4: Run awdf flash.exe to upgrade the BIOS.**

1. If the BIOS Setup is correct, it will restart and boot from the USB disk.
2. Run **awdf flash xxxxxxx.Sxx** from the command line to upgrade the BIOS. Replace xxxxxxx.Sxx with the BIOS binary file name discussed in Step 2.
3. Press **F1** to reset the system after the bios update is complete. The system should reboot at this time.

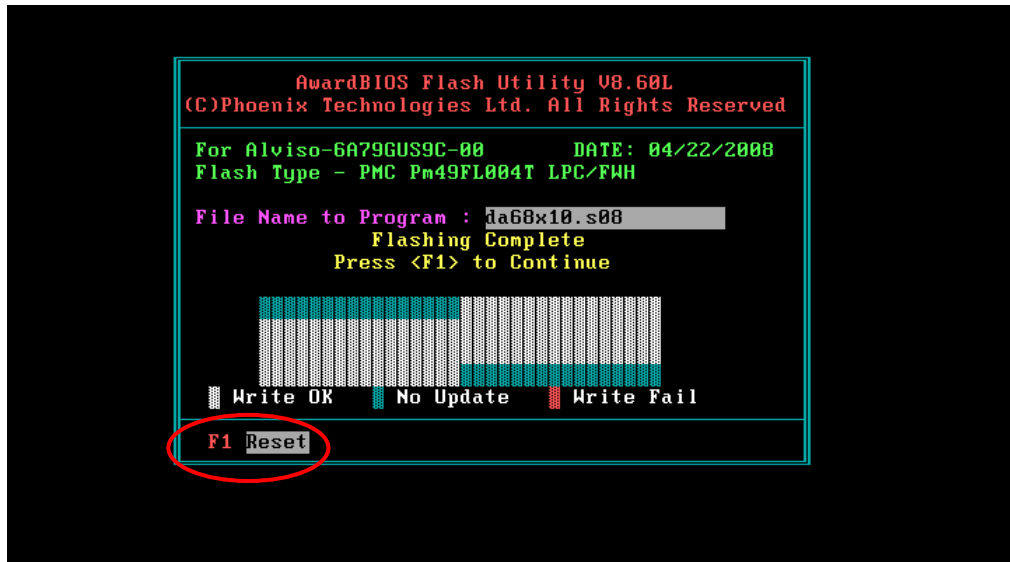
**ATTENTION**

Do **NOT** switch off the power supply during the BIOS upgrade, since doing so may cause the system to crash.

**Step 5: Load BIOS Default.**

1. If the BIOS upgrade is successful, it should reboot and the following screen should appear.

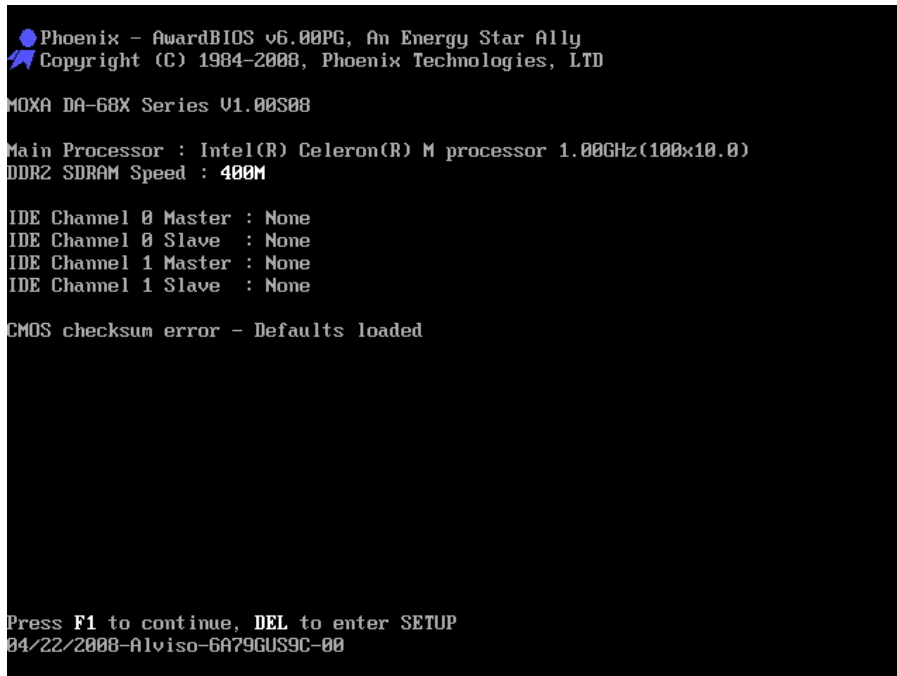

2. Press **DEL** to open the BIOS Setup menu.
3. Select **Defaults** → **Load System Default Settings** and then choose **Y**.
4. Select **Exit** → **Save & Exit Setup** and then press **Enter** to choose **Y** to save the settings to CMOS and exit.

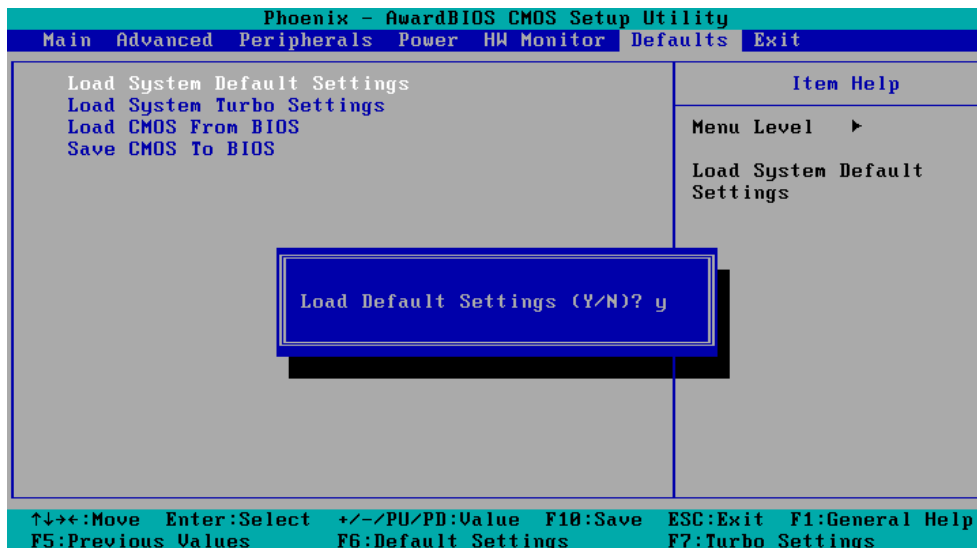

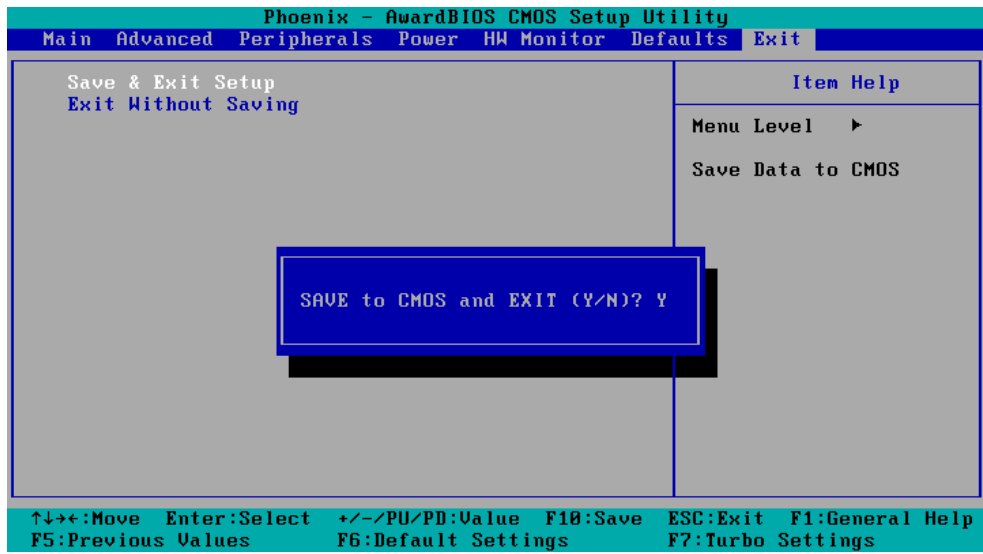

# A

## Safety Installation Instructions

---

### A. RTC Battery Warning

**CAUTION:** There is a risk of explosion if battery is replaced by an incorrect type. Dispose of used batteries according to the instructions.

### B. Fuse Warning

**CAUTION:** For continued protection against fire, replace only with same type and rating of fuse.

### C. Rackmount Warning

The following or similar rackmount instructions are included with the installation instructions:

**(1) Elevated Operating Ambient:** If installed in a closed or multi-unit rack assembly, the operating ambient temperature of the rack environment may be greater than the room ambient temperature. Therefore, consideration should be given to installing the equipment in an environment compatible with the maximum ambient temperature (T<sub>ma</sub>) specified by the manufacturer.

**(2) Reduced Air Flow:** Installation of the equipment in a rack should be such that the amount of air flow required for safe operation of the equipment is not compromised.

**(3) Mechanical Loading:** Mounting of the equipment in the rack should be such that a hazardous condition is not achieved due to uneven mechanical loading.

**(4) Circuit Overloading:** Consideration should be given to the connection of the equipment to the supply circuit and the effect that overloading of the circuits might have on overcurrent protection and supply wiring. Appropriate consideration of equipment nameplate ratings should be used when addressing this concern.

**(5) Reliable Grounding:** Reliable grounding of rack-mounted equipment should be maintained. Particular attention should be given to supply connections other than direct connections to the branch circuit (e.g., by using power strips).