

UC-8416 Series

RISC ready-to-run embedded computers with 8 serial ports, 3 LANs, DIO, 8 Ethernet ports, USB, CompactFlash



- > Intel XScale IXP435 533 MHz processor
- > 256 MB DDR2 SDRAM and 16 MB Flash ROM onboard
- > 32 MB NAND Flash for data storage
- > 256 KB battery backup SRAM
- > 8 RS-232/422/485 serial ports
- > 8 10/100 Mbps unmanaged switch ports
- > 4 digital input and 4 digital output channels
- > 3 10/100 Mbps Ethernet ports
- > 2 USB 2.0 hosts for mass storage devices
- > CompactFlash socket for storage expansion
- > Supports IPv6 function (Linux model only)
- > DIN-Rail or wall mount installation
- > Robust, fanless design
- > -40 to 75°C wide temperature model available
- > Ready-to-run Embedded Linux or Windows CE 6.0



Overview

The UC-8416 Series embedded computers come with 8 RS-232/422/485 serial ports, 3 Ethernet ports, 8 unmanaged switch ports, 4 digital input channels, 4 digital output channels, a CompactFlash socket, and 2 USB 2.0 hosts.

The computers use the Intel XScale IXP435 533 MHz RISC CPU. This powerful computing engine supports several useful communication functions, but will not generate too much heat. The built-in 16 MB NOR Flash ROM and 256 MB SDRAM give you enough memory to run your application software directly on the UC-8416, and the 32 MB NAND Flash can be used to provide additional data storage. Moreover, the 256 KB SRAM offers a better data retention mechanism for avoiding data loss. The UC-8416 computers come with 8 RS-232/422/485

serial ports, switch ports, digital I/O, and have 3 LAN ports, making them ideal as a communication platform for industrial applications that require network redundancy.

The UC-8416 Series comes with the Linux 2.6 or Windows CE 6.0 platform pre-installed to provide an open software operating system for software program development. Software written for a desktop PC can be easily ported to the UC-8416 Series platform by using a common compiler, without needing to modify the code. This makes the UC-8416 an optimal solution for use with industrial applications, but with minimal cost and effort.

In addition to the standard model, a -40 to 75°C wide temperature model is also available for harsh industrial environments.

Appearance

Front View

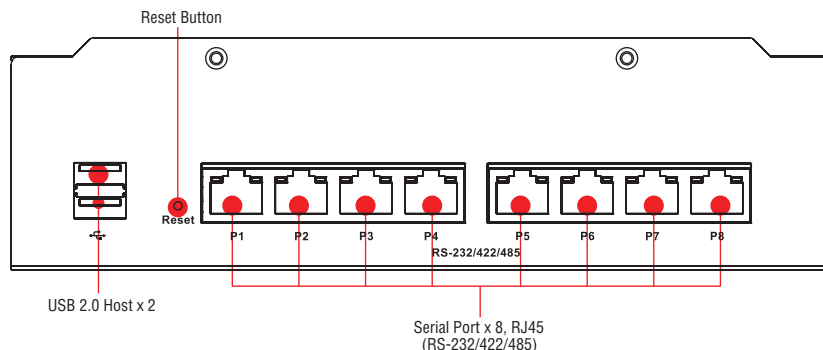

Rear View

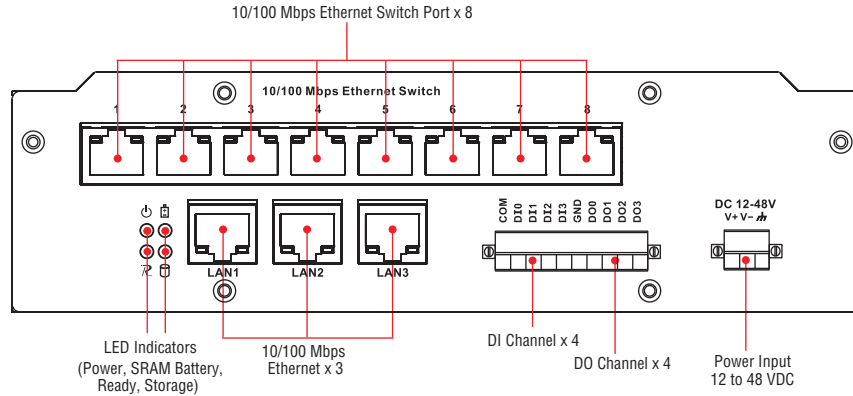

Hardware Specifications

Computer

CPU: Intel XScale IXP435, 533 MHz
OS (pre-installed): Linux
DRAM: 256 MB DDR2 SDRAM onboard (512 MB max.)
SRAM: 256 KB, battery backup
Flash:
 16 MB NOR Flash onboard to store OS (supports up to 32 MB)
 32 MB NAND Flash onboard to store data
Expansion Bus: PCI/104 onboard
USB: USB 2.0 compliant hosts x 2, type A connector

Storage

Storage Expansion: CompactFlash socket

Ethernet Interface

LAN: 3 auto-sensing 10/100 Mbps ports (RJ45)
Switch Ports: 8 10/100 Mbps unmanaged ports
Magnetic Isolation Protection: 1.5 KV built-in

Serial Interface

Serial Standards: 8 RS-232/422/485 ports, software-selectable (8-pin RJ45)
Console Port: RS-232 (TxD, RxD, GND), 4-pin header output (115200, n, 8, 1)

Serial Communication Parameters

Data Bits: 5, 6, 7, 8
Stop Bits: 1, 1.5, 2
Parity: None, Even, Odd, Space, Mark
Flow Control: RTS/CTS, XON/XOFF, ADDC® (automatic data direction control) for RS-485
Baudrate: 50 bps to 921.6 Kbps (supports non-standard baudrates; see user's manual for details)

Serial Signals

RS-232: TxD, RxD, DTR, DSR, RTS, CTS, DCD, GND
RS-422: TxD+, TxD-, RxD+, RxD-, GND
RS-485-4w: TxD+, TxD-, RxD+, RxD-, GND
RS-485-2w: Data+, Data-, GND

Digital Input

Input Channels: 4, source type
Input Voltage: 0 to 30 VDC
Digital Input Levels for Dry Contacts:
 • Logic level 0: Close to GND
 • Logic level 1: Open
Digital Input Levels for Wet Contacts:
 • Logic level 0: +3V max.
 • Logic level 1: +10V to +30V (COM to DI)
Connector Type: 10-pin screw terminal block (4 points, COM, GND)
Isolation: 3 KV optical isolation

Digital Output

Output Channels: 4, sink type
Output Current: Max. 200 mA per channel
On-state Voltage: 24 VDC nominal, open collector to 30 V
Connector Type: 10-pin screw terminal block (4 points, GND)
Isolation: 3 KV optical isolation

LEDs

System: Power, Ready, Storage, Battery for SRAM
LAN: 10M/Link x 2, 100M/Link x 2 (on connector)
Serial: TxD x 8, RxD x 8

Reset Button: Supports "Reset to Factory Default"

Physical Characteristics

Housing: SECC sheet metal (1 mm)
Weight: 1 kg
Dimensions: 200 x 57 x 120 mm (7.87 x 2.24 x 4.72 in)
Mounting: DIN-Rail, wall

Environmental Limits

Operating Temperature:
 Standard Models: -10 to 60°C (14 to 140°F)
 Wide Temp. Models: -40 to 75°C (-40 to 167°F)
Storage Temperature:
 Standard Models: -20 to 75°C (-4 to 167°F)
 Wide Temp. Models: -40 to 85°C (-40 to 185°F)
Ambient Relative Humidity: 5 to 95% (non-condensing)
Anti-vibration: 2 g rms @ IEC-68-2-34, random wave, 5-500 Hz, 1 hr per axis
Anti-shock: 20 g @ IEC-68-2-27, half sine wave, 11 ms

Power Requirements

Input Voltage: 12 to 48 VDC (3-pin terminal block)
Power Consumption: 15 W
 • 310 mA @ 48 VDC
 • 625 mA @ 24 VDC
 • 1350 mA @ 12 VDC

Regulatory Approvals

Safety: UL 60950-1, EN 60950-1, CCC (GB9254, GB17625.1)
EMC: EN 55022 Class B, EN 55024-4-2, EN 55024-4-3, EN 55024-4-4, FCC Part 15 Subpart B Class B

Reliability

Alert Tools: Built-in buzzer and RTC (real-time clock)
Automatic Reboot Trigger: Built-in WDT (watchdog timer)
MTBF (mean time between failures): 156,942 hrs

Warranty

Warranty Period: 5 years
Details: See www.moxa.com/warranty

Note: The Hardware Specifications apply to the embedded computer unit itself, but not to accessories. In particular, the wide temperature specification does not apply to accessories such as the power adaptor and cables.

Software Specifications

Linux

OS: Linux 2.6.23

File System: JFFS2, NFS, Ext2, Ext3

Internet Protocol Suite: TCP, UDP, IPv4, IPv6, SNMPv1, ICMP, ARP, HTTP, CHAP, PAP, DHCP, NTP, NFS, SMTP, Telnet, FTP, TFTP, PPP, PPPoE

Internet Security: OpenVPN, iptables firewall

Web Server (Apache): Allows you to create and manage web sites; supports PHP and XML

Terminal Server (SSH): Provides secure encrypted communications between two un-trusted hosts over an insecure network

Dial-up Networking: PPP Daemon for Linux that allows Unix machines to connect to the Internet through dialup lines, using the PPP protocol, as a PPP server or client. Works with 'chat', 'dip', and 'diald', among (many) others. Supports IP, TCP, UDP, and (for Linux) IPX (Novell).

Watchdog: Features a hardware function to trigger system reset in a user specified time interval (Moxa API provided)

Application Development Software:

- Moxa API Library (Watchdog timer, Moxa serial I/O control, Moxa DI/DO API)
- GNU C/C++ cross-compiler
- GNU C library
- GDB source-level debugging server

Software Protection: Encryption tool for user executable files (based on patented Moxa technology)

Windows Embedded CE 6.0

OS: Windows Embedded CE 6.0

File System: FAT

Internet Protocol Suite: TCP, UDP, IPv4, IPv6, SNMPv2, ICMP, IGMP, ARP, HTTP, CHAP, PAP, SSL, DHCP, SNTP, SMTP, Telnet, FTP, PPP

Web Server (WinCE IIS): Supports ASP, ISAPI Secure Socket Layer (SSL 2/3) and Transport Layer Security (TLS/SSL 3.1) public key-based protocols, and Web Administration ISAPI Extensions

Dial-up Networking: Supports RAS client API and PPP, Extensible Authentication Protocol (EAP), and RAS scripting

Watchdog: Features a hardware function to trigger system reset in a user specified time interval. (Moxa API provided)

Application Development Software:

- Moxa WinCE 6.0 SDK
- Moxa API Library
- C Libraries and Run-times
- Component Services (COM and DCOM)
- Microsoft® .NET Compact Framework 3.5
- XML, including DOM, XQL, XPATH, XSLT, SAX, SAX2
- SOAP Toolkit Client
- Winsock 2.2

Dimensions

Unit: mm (inch)

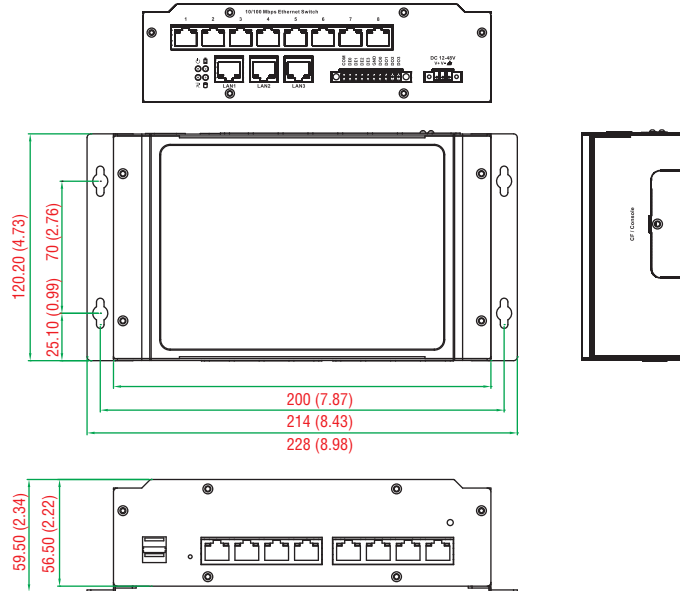

: Ordering Information

Available Models

UC-8416-LX: RISC-based industrial embedded computer with 8 serial ports, 4 DIs, 4 DOs, 3 LANs, 8 switch ports, CompactFlash, USB, Linux OS, -10 to 60°C operating temperature

UC-8416-CE: RISC-based industrial embedded computer with 8 serial ports, 4 DIs, 4 DOs, 3 LANs, 8 switch ports, CompactFlash, USB, Windows CE 6.0 OS, -10 to 60°C operating temperature

UC-8416-T-LX: RISC-based industrial embedded computer with 8 serial ports, 4 DIs, 4 DOs, 3 LANs, 8 switch ports, CompactFlash, USB, Linux OS, -40 to 75°C operating temperature

UC-8416-T-CE: RISC-based industrial embedded computer with 8 serial ports, 4 DIs, 4 DOs, 3 LANs, 8 switch ports, CompactFlash, USB, Windows CE 6.0 OS, -40 to 75°C operating temperature

Package Checklist

- UC-8416 embedded computer
- Wall mounting kit
- DIN-Rail mounting kit
- Ethernet cable: RJ45 to RJ45 cross-over cable, 100 cm
- CBL-4PINDB9F-100: 4-pin pin header to DB9 female console port cable, 100 cm
- Universal power adaptor (including power jack converter)
- Documentation and software CD
- Quick installation guide (printed)
- Warranty card